

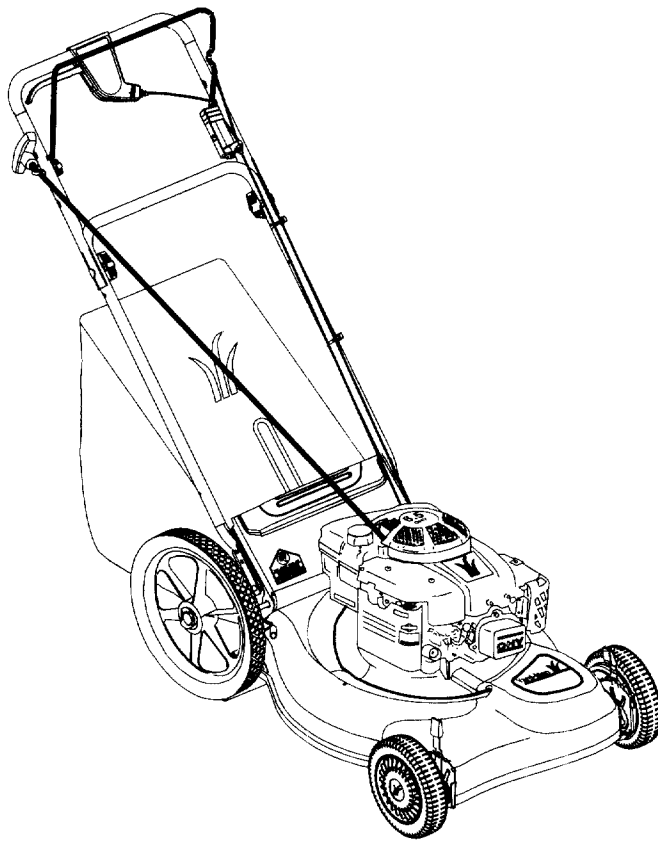

# OPERATOR'S MANUAL



21" Self-Propelled  
Mulching Mower  
Model No.  
12A-559K401



## IMPORTANT: READ SAFETY RULES AND INSTRUCTIONS CAREFULLY

**Warning:** This unit is equipped with an internal combustion engine and should not be used on or near any unimproved forest-covered, brush-covered or grass-covered land unless the engine's exhaust system is equipped with a spark arrester meeting applicable local or state laws (if any). If a spark arrester is used, it should be maintained in effective working order by the operator. In the State of California the above is required by law (Section 4442 of the California Public Resources Code). Other states may have similar laws. Federal laws apply on federal lands. A spark arrester for the muffler is available through your nearest engine authorized service dealer or contact the service department, P.O. Box 368022 Cleveland, Ohio 44136-9722.

**MTD PRODUCTS INC. P.O. BOX 368022 CLEVELAND, OHIO 44136-9722**

---

## SECTION 1: FINDING MODEL NUMBER

This owner's guide is an important part of your new Yard-Man lawn mower. It will help you to assemble, prepare and maintain your mower. Please read and understand what it says.

Before you start assembling the mower for its first use, please locate its model plate and copy the information on to this owner's guide. The information on the model plate is very important if you need help from your nearest service center or the Yard-Man customer support department.

- Every mower has a model plate. You can locate it by standing behind the unit in the operating position and looking down at the cutting deck. An example of the model plate is shown below.

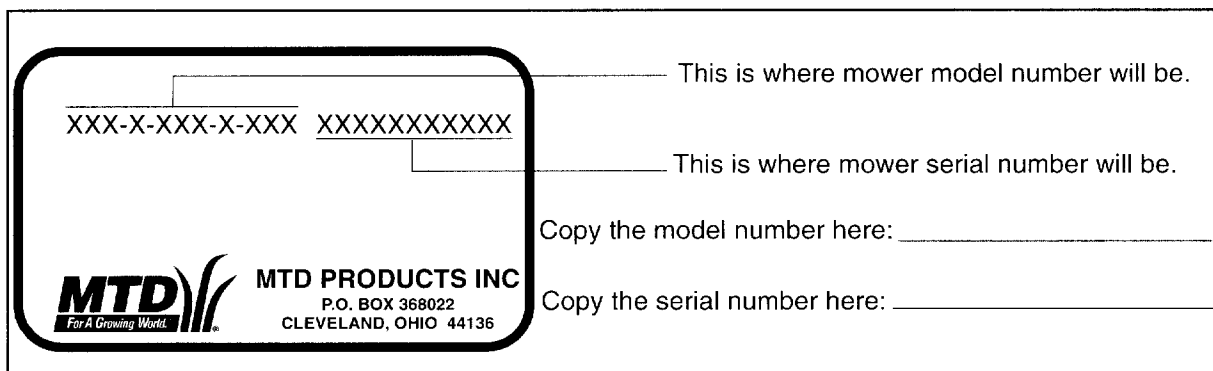

---

## SECTION 2: CALLING CUSTOMER SUPPORT

- **LOCATE YOUR MODEL NUMBER AND SERIAL NUMBER** — Record this information in the space provided. To find your unit's specific model number and serial number, see SECTION 1: FINDING YOUR MODEL NUMBER.
- If you are having difficulty assembling this product or if you have any questions regarding the controls, operation or maintenance of this unit, please call the Customer Support Department.
- Customer Support can be reached by dialing: **1- (330) 220-4MTD (4683)**  
or  
**1- (800)-800-7310**
- Please have your model number and serial number ready when you call.
- Although both numbers are important, you will be asked to enter only your **serial** number before your call can be processed.

---

## SECTION 3: IMPORTANT SAFE OPERATION PRACTICES



**WARNING:** THIS SYMBOL POINTS OUT IMPORTANT SAFETY INSTRUCTIONS WHICH, IF NOT FOLLOWED, COULD ENDANGER THE PERSONAL SAFETY AND/OR PROPERTY OF YOURSELF AND OTHERS. READ AND FOLLOW ALL INSTRUCTIONS IN THIS MANUAL BEFORE ATTEMPTING TO OPERATE YOUR LAWN MOWER. FAILURE TO COMPLY WITH THESE INSTRUCTIONS MAY RESULT IN PERSONAL INJURY. WHEN YOU SEE THIS SYMBOL, HEED ITS WARNING.



**WARNING:** The Engine Exhaust from this product contains chemicals known to the State of California to cause cancer, birth defects or other reproductive harm.



**DANGER:** Your lawn mower was built to be operated according to the rules for safe operation in this manual. As with any type of power equipment, carelessness or error on the part of the operator can result in serious injury. This lawn mower is capable of amputating hands and feet and throwing objects. Failure to observe the following safety instructions could result in serious injury or death.

### 1. GENERAL OPERATION

- Read this operator's manual carefully in its entirety before attempting to assemble this machine. Read, understand, and follow all instructions on the machine and in the manual(s) before operation. Be completely familiar with the controls and the proper use of this machine before operating it. Keep this manual in a safe place for future and regular reference and for ordering replacement parts.
- Your rotary mower is a precision piece of power equipment, not a plaything. Therefore, exercise extreme caution at all times. Your unit has been designed to perform one job: to mow grass. Do not use it for any other purpose.
- Never allow children under 14 years old to operate a power mower. Children 14 years old and over should only operate mower under close parental supervision. Only responsible individuals who are familiar with these rules of safe operation should be allowed to use your mower.
- Keep the area of operation clear of all persons, particularly small children and pets. Stop engine when they are in the vicinity of your mower to help prevent blade contact or thrown object injury. Although the area of operation should be completely cleared of foreign objects, an object may have been overlooked and could be accidentally thrown by the mower in any direction and cause serious personal injury to the operator or any others allowed in the area.
- Wear sturdy, rough-soled work shoes and close-fitting slacks and shirts. Shirts and pants that cover the arms and legs and steel-toed shoes are recommended. Do not wear loose fitting clothes or jewelry. They can be caught in moving parts. Never operate a unit in bare feet, sandals, slippery or light weight (e.g. canvas) shoes.
- Always wear safety glasses or safety goggles during operation or while performing an adjustment or repair, to protect eyes from foreign objects that may be thrown from the machine in any direction.
- Thoroughly inspect the area where the equipment is to be used. Remove all stones, sticks, wire, bones, toys and other foreign objects which could be picked up and thrown by the mower in any direction and cause serious personal injury to the operator or any others allowed in the area. Plan your mowing pattern to avoid discharge of material toward roads, sidewalks, bystanders and the like. To help avoid a thrown objects injury, keep children, bystanders and helpers at least 75 feet from the mower while it is in operation.
- Do not put hands or feet near or under rotating parts. Keep clear of discharge opening at all times as the rotating blade can cause injury.
- Many injuries occur as a result of the mower being pulled over the foot during a fall. Do not hang on to the mower if you are falling; release the handle immediately.
- Never pull the mower toward you while you are walking. If you must back the mower away from a wall or obstruction first look down and behind, and then follow these steps:
  - Step back from the mower to fully extend your arms.
  - Be sure you are well balanced with sure footing.
  - Pull the mower back slowly, no more than half way toward you.
  - Repeat these steps as needed.
- Do not operate the mower while under the influence of alcohol or drugs.

- Do not engage the self-propelled mechanism on units so equipped while starting engine.
- The blade control handle is a safety device. Never attempt to bypass its operation. Doing so makes the safety device inoperative and may result in personal injury through contact with the rotating blade. The blade control handle must operate easily in both directions and automatically return to the disengaged position when released.
- Never operate the mower in wet grass. Always be sure of your footing. A slip and fall can cause serious personal injury. Keep a firm hold on the handle and walk, never run. If you feel you are losing your footing, **RELEASE THE BLADE CONTROL HANDLE IMMEDIATELY** and the blade will stop rotating within three seconds.
- Mow only in daylight or good artificial light.
- Stop the blade when crossing gravel drives, walks or roads.
- If the equipment should start to vibrate abnormally, stop the engine and check immediately for the cause. Vibration is generally a warning of trouble.
- Shut the engine off and wait until the blade comes to a complete stop before removing the grass catcher or unclogging the chute. The cutting blade continues to rotate for a few seconds after the engine is shut off. Never place any part of the body in the blade area until you are sure the blade has stopped rotating.
- Never operate mower without proper guards, grass catcher, plates or other safety protective devices in place.
- Muffler and engine become hot and can cause a burn. Do not touch.
- Only use accessories approved for this machine by the manufacturer. Read, understand, and follow all instructions provided with the approved accessory.
- If situations occur which are not covered in this manual, use care and good judgment. Contact your dealer for assistance.

## 2. SLOPE OPERATION

For your safety, use the slope gauge included as part of this manual to measure slopes before operating this unit on a sloped or hilly area. If the slope is greater than 15 degrees as shown on the slope gauge, do not operate this unit on that area or serious injury could result.

### DO:

- Mow across the face of slopes; never up and down. Exercise extreme caution when changing direction on slopes.
  - Always be sure of your footing. A slip and fall can cause serious personal injury. If you feel you are losing your balance release the blade control handle immediately and the blade will stop in less than 3 seconds.
- Watch for holes, ruts, hidden objects, or bumps. Tall grass can hide obstacles.

### DO NOT:

- Do not mow near drop-offs, ditches or embankments. The operator could lose footing or balance.
- Do not mow slopes greater than 15 degrees as shown on the slope gauge.
- Do not mow on wet grass. Reduced footing could cause slipping.

## 3. CHILDREN

Tragic accidents can occur if the operator is not alert to the presence of children. Children are often attracted to the mower and the mowing activity. Never assume that children will remain where you last saw them.

- Keep children out of the mowing area and under the watchful care of a responsible adult other than the operator.
- Be alert and turn mower off if a child enters the area.
- Before and while moving backwards, look behind and down for small children or other objects.
- Never allow children under age 14 to operate the mower. Children 14 years of age and above should read and understand the operation instructions and safety rules in this manual.
- Use extreme care when approaching blind corners, shrubs, trees, or other objects that may obscure your vision of a child or hazard.

## 4. SERVICE

- Use extreme care in handling gasoline and other fuels. They are extremely flammable and the vapors are explosive.
- Use only an approved gasoline container.
- Never remove gas cap or add fuel while the engine is running. Allow engine to cool at least two minutes before refueling.
- Replace gasoline cap securely and wipe off any spilled gasoline before starting the engine as it may cause a fire or explosion.
- Extinguish all cigarettes, cigars, pipes and other sources of ignition.
- Never refuel machine indoors because flammable vapors will accumulate in the area.
- Never store the machine or fuel container inside where there is an open flame or spark such as a gas water heater, space heater, or furnace.
- Never run an engine inside a closed area.
- To reduce fire hazard, keep mower free of grass, leaves, or other debris build-up. Clean up oil or fuel spillage. Allow mower to cool at least 5 minutes before storing.

- Before cleaning, repairing, or inspecting, make certain the blade and all moving parts have stopped. Disconnect the spark plug wire, and keep the wire away from the spark plug to prevent accidental starting.
- Check the blade and engine mounting bolts at frequent intervals for proper tightness. Also, visually inspect blade for damage (e.g., bent, cracked or worn). Replace with blade which meets original equipment specifications listed in this manual.
- Keep all nuts, bolts, and screws tight to be sure the equipment is in safe working condition.
- Never tamper with safety devices. Check their proper operation regularly.
- After striking a foreign object, stop the engine, remove the wire from the spark plug, and

thoroughly inspect the mower for any damage. Repair the damage before starting and operating the mower.

- Never attempt to make a wheel or cutting height adjustment while the engine is running.
- Grass catcher components are subject to wear, damage and deterioration, which could expose moving parts or allow objects to be thrown. For safety protection, frequently check components and replace with manufacturer's recommended parts, when necessary.
- Mower blades are sharp and can cut. Wrap the blade(s) or wear gloves, and use extra caution when servicing them.
- Do not change the engine governor setting or overspeed the engine. Excessive engine speeds are dangerous.



**WARNING - YOUR RESPONSIBILITY:** Restrict the use of this power machine to persons who read, understand and follow the warnings and instructions in this manual and on the machine.



## SECTION 4: SLOPE GAUGE

Use this page as a guide to determine slopes where you may not operate safely.

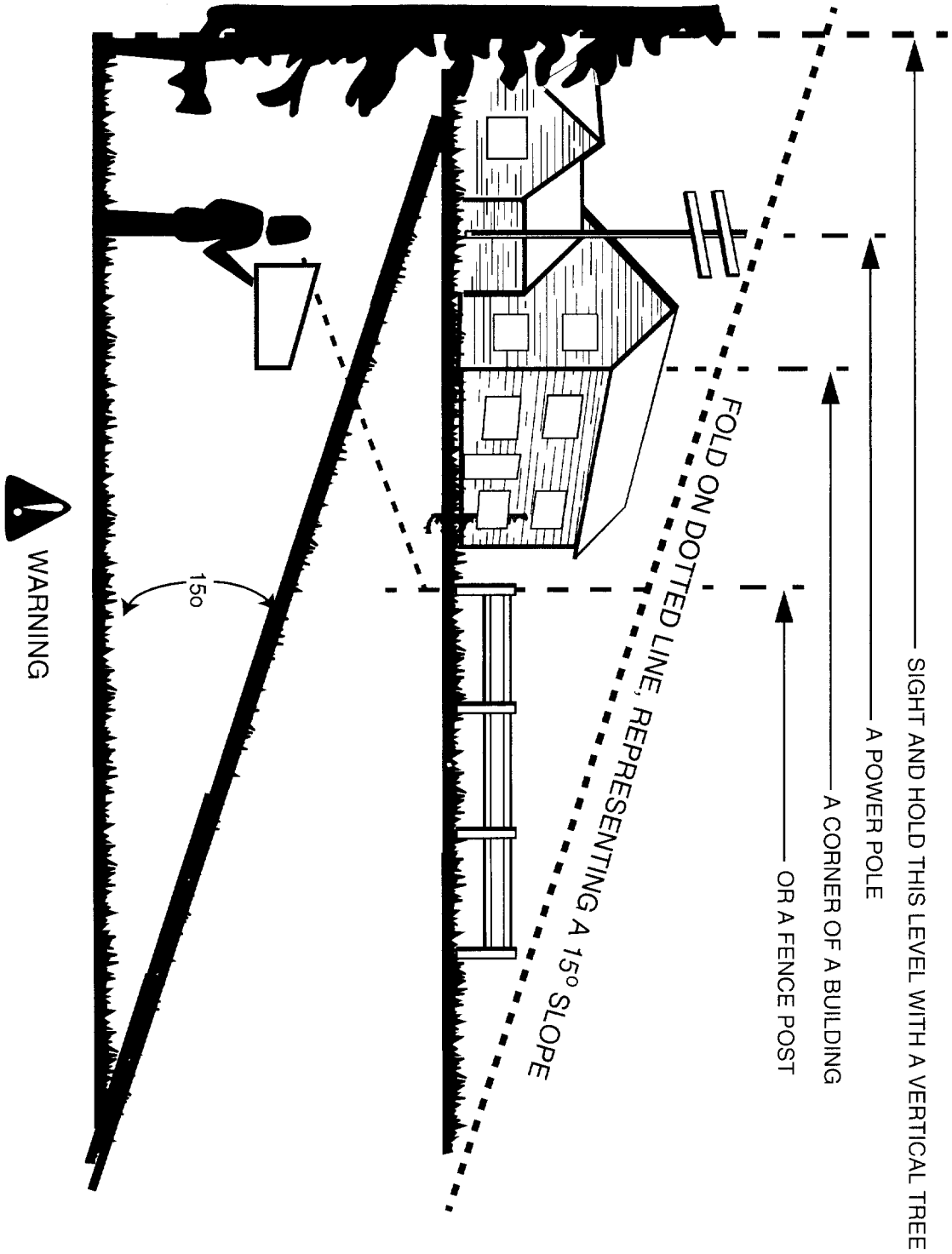

Do not mow on inclines with a slope in excess of 15 degrees (a rise of approximately 2-1/2 feet every 10 feet). A riding mower could overturn and cause serious injury. If operating a walk-behind mower on such a slope, it is extremely difficult to maintain your footing and you could slip, resulting in serious injury.

Operate RIDING mowers up and down slopes, never across the face of slopes.

---

## SECTION 5: UNPACKING

### Removing Unit From Carton

- Remove staples, break glue on top flaps, or cut tape at carton end and peel along top flap to open carton.
- Remove loose parts if included with unit (i.e., owner's manual, etc.).
- Cut along dotted lines and lay carton down flat. Remove packing material.
- Roll or slide unit out of carton. Check carton thoroughly for loose parts.

**NOTE:** Make sure not to crimp the cables while removing the loose parts or the entire unit from the carton.

**NOTE:** Reference to right or left hand side of the mower and/or front or behind the mower is observed from the operating position.

---

## SECTION 6: SETTING UP MOWER

### Tools Required

- Pair of Pliers
- Funnel
- Set of adjustable wrenches

### Disconnecting Spark Plug

- Before setting up your lawn mower, disconnect the spark plug wire from the spark plug, and ground it against the engine. See Figure 1.
- Attach the spark plug wire to a bolt on the engine to ground it.

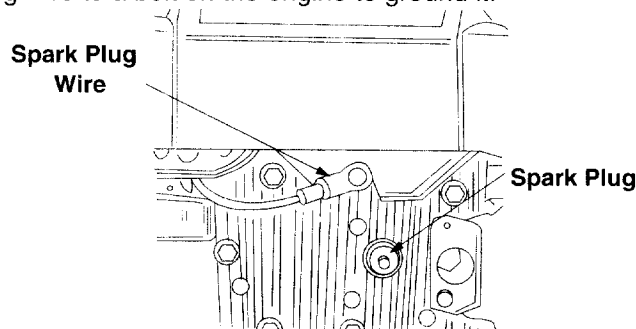

FIGURE 1

### Assembling Handle

- Remove grass bag from the unit and set it out of the way. See Figure 2 (step 1).

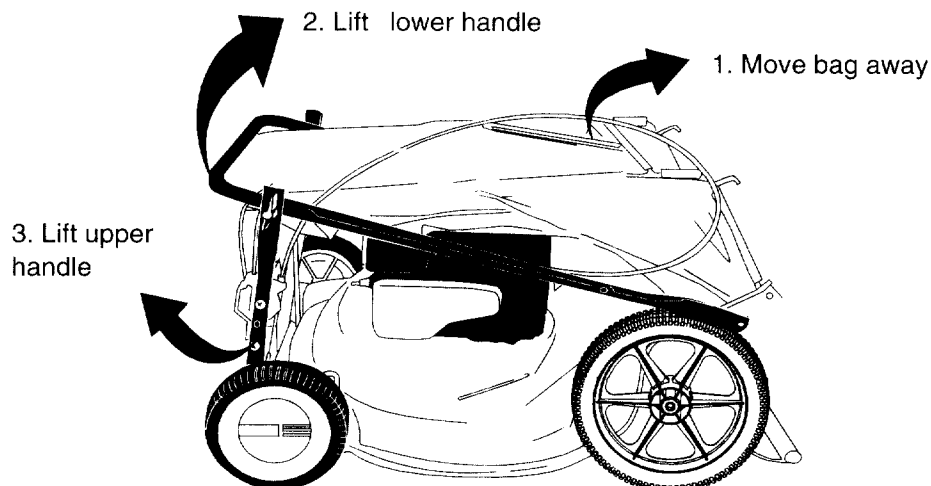

FIGURE 2

- Raise the lower handle in the direction shown in Figure 2 (step 2) till it snaps into place.
- Raise the upper handle in the direction shown in Figure 2 (step 3). Tighten the wing nuts which are already on the handle. See Figure 3A.

**Note:** Make sure to route the cables inside the lower handle. Also do not crimp the cables while lifting the handle up.

- For shipping purposes, the hairpin clip is placed in the outer hole of the weld pin on the lower handle. Remove the hairpin clip from the outer hole of the weld pin.
- Using a pair of pliers, insert the hairpin clip into the inner hole in the weld pin. Repeat on other side. See Figure 3B.
- Attach the cables to the lower handle with the two cable ties already on the lower handle. Pull tight the cable ties and cut off the extra. See Figure 3C below.

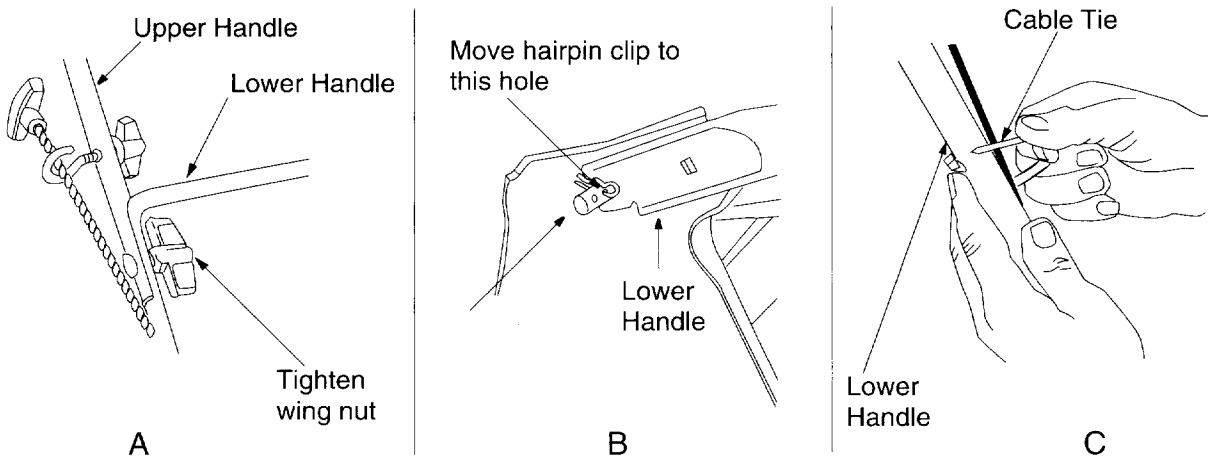

FIGURE 3

### Attaching Starter Rope

The rope guide is already attached to the right side of the upper handle of your mower. See Figure 4.

- With the spark plug wire disconnected and grounded, hold the blade control handle against the upper handle, and pull the starter rope out of the engine.
- Slip the rope through the rope guide as shown below. Tighten the wing nut holding the rope guide to the upper handle.

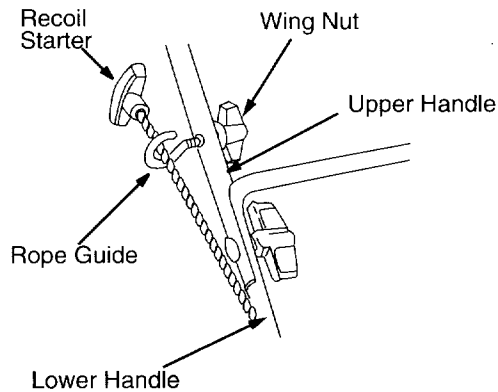

FIGURE 4



## Attaching Grasscatcher

- Lift the rear discharge door and remove the rear mulching baffle from the mower. See Figure 5.

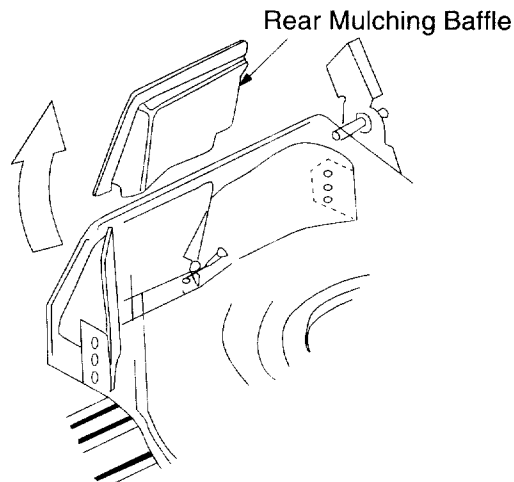

FIGURE 5

**NOTE:** Make sure that the cables are routed to the outside of the handle and out of the way when attaching the grasscatcher.

- Place the hooks of the grasscatcher into the slots in the handle bracket assemblies on both sides. See Figure 6. Release the rear discharge door.
- To remove the grasscatcher, lift the rear discharge door on the mower. Lift the grasscatcher up, out of the slots in the handle bracket assemblies. Reinstall the plastic rear mulching baffle and release the rear discharge door.

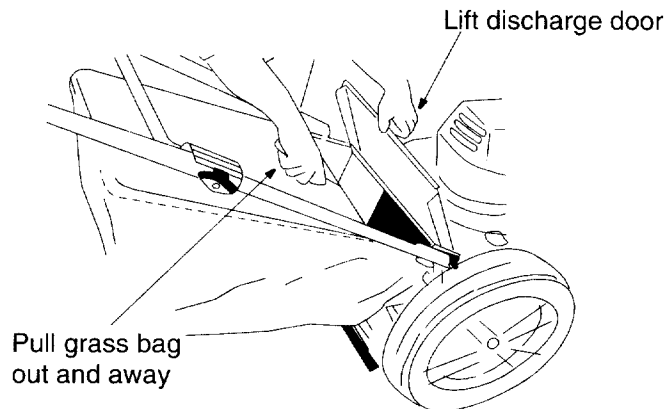

FIGURE 6

**NOTE:** For instructions on how to bag the grass clippings, please refer to page 13 of this manual.



**WARNING:** Never operate the mower unless the hooks on the grasscatcher are seated in the slots on the handle bracket assemblies, and the rear discharge door rests firmly against the top of the grasscatcher.

---

## SECTION 7: CONTROLS

Read this owner's manual and safety rules before operating your lawn mower. Compare the illustrations in Figure 7 with your lawn mower to familiarize yourself with the location of various controls and adjustments. Save this manual for future reference.

The operation of any lawn mower can result in foreign objects being thrown into the operator's eyes thus causing severe eye damage. **Always wear safety glasses** while operating the mower, or while performing any adjustments or repairs on it.

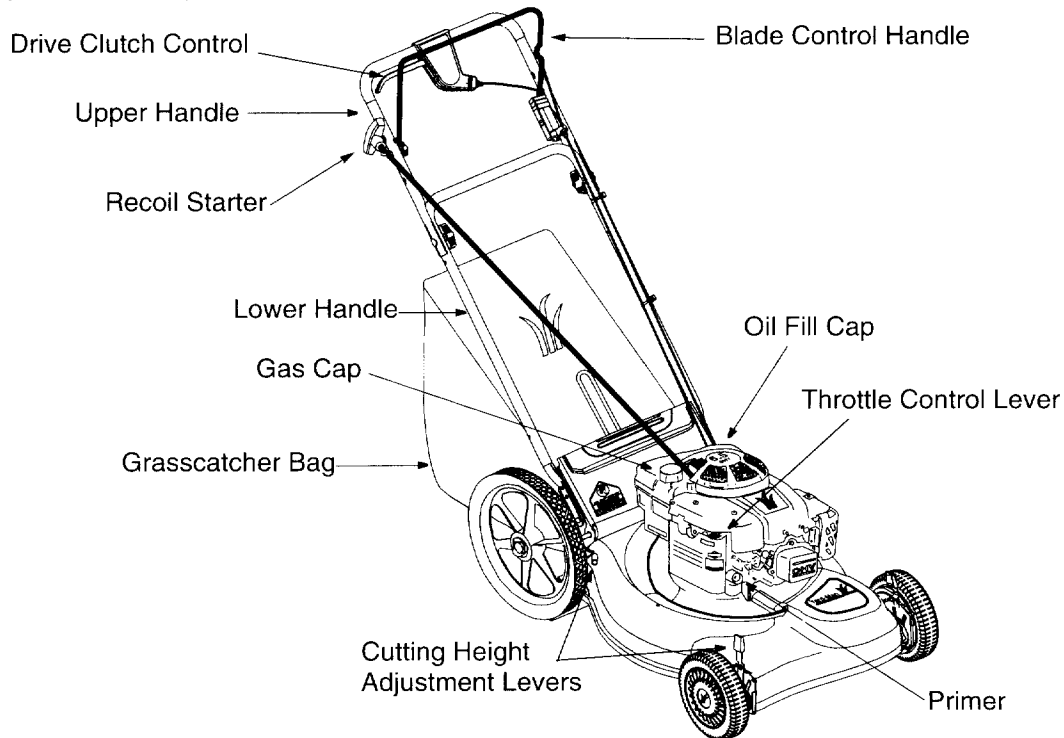

FIGURE 7

### Recoil Starter

The recoil starter is attached to the handle. Stand behind the unit and pull the recoil starter to start the unit.

### Primer

The primer is used to pump gas into the carburetor. Use it to assist in starting a cold engine, but do not use it when restarting a warm engine after a short shutdown. Refer to Figure 8.

### Blade Control Handle



**WARNING:** This control mechanism is a safety device. Never attempt to bypass its operations or alter it in any way.

The blade control handle is located on the upper handle of the mower. The blade control handle must be depressed in order to operate the unit. Release the blade control handle to stop the engine and the blade.

### Throttle Control Lever



**WARNING:** Never attempt to adjust the engine's throttle speed while the engine is running. Always stop the engine by releasing the blade control handle before adjusting the engine's throttle speed.

The throttle control lever is located on the side of the engine and is used to regulate engine speed.

## Drive Clutch Control

The drive clutch control lever is located on the upper handle and is used to engage the drive. Squeeze the lever against the upper handle to engage the drive; release the drive clutch control to slow down or stop the mower.

---

# SECTION 8: OPERATION

## Gas And Oil Fill-Up

### Oil:

- Only use high quality detergent oil rated with API service classification SF, SG or SH. Use SAE30 oil only.
- Fill oil sump and check the oil level following steps below.
  - a. Position the mower on level ground and clean area around oil fill cap.
  - b. Remove oil fill cap and dipstick. Wipe dipstick clean, insert it into oil fill hole and tighten securely.
  - c. Remove dipstick and check oil level. If the oil is not upto FULL mark on the dipstick, pour recommended oil through the oil fill and check the level again.
- Install oil fill cap and dipstick, tighten securely.

**NOTE:** Although multi-viscosity oils (5W30, 10W30, etc.) improve starting in cold weather, these multiviscosity oils will result in increased oil consumption when used above 32°F. Check the oil level more frequently to avoid possible engine damage from running low on oil.

### Gasoline



**WARNING:** Never fill fuel tank indoors, or when engine is running or hot. Do not smoke when filling up the fuel tank.

- Clean area around gas cap. Remove cap. Use a funnel to prevent spillage.
- Pour approximately 1.5 quarts of fresh, regular grade, unleaded gasoline slowly into the fuel tank.

**IMPORTANT:** Never mix engine oil with gasoline.

- Fill tank to 1/2" below the bottom of the filler neck to allow space for fuel expansion. Wipe any fuel spillage. **Do not fill fuel tank completely.**

## Before Starting Mower

- Attach spark plug wire to spark plug. Make certain the metal cap on the end of the spark plug wire (inside the rubber boot) is fastened securely over the metal tip on the spark plug.
- Check the drive clutch control for proper adjustment. If the mower does not propel itself or the drive wheels hesitate with the drive clutch engaged, perform the drive clutch control adjustment as instructed on page 18 of this manual.

## Adjusting Throttle Speed

The throttle control lever is located on the right side of the engine. Adjust as follows:

- Slide the throttle control lever toward the turtle (front of the engine) to slow the engine's RPM. Slide the throttle control lever toward the rabbit (rear of the engine) to speed up the engine's RPM. See Figure 8.

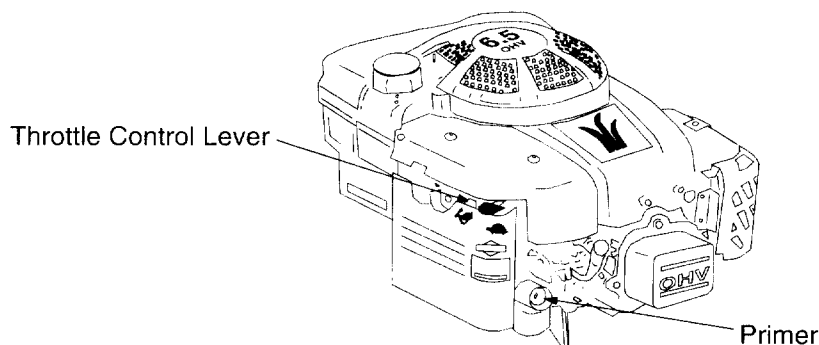

FIGURE 8

- Always operate your mower with the engine in the full throttle (rabbit) position for the most effective mulching or bagging of the cut grass.



**WARNING:** Never attempt to adjust the engine's throttle speed while the engine is running. Always stop the engine by releasing the blade control handle before adjusting the engine's throttle speed.

## Starting Engine



**WARNING:** Be sure no one other than the operator is standing near the lawn mower while starting engine or operating mower.

Never run engine indoors or in enclosed, poorly ventilated areas. Engine exhaust contains carbon monoxide, an odorless and deadly gas.

Keep hands, feet, hair and loose clothing away from any moving parts on engine and lawn mower.

When starting the unit for the first time, face the mower against a solid object such as a wall, fence, etc. Start the unit and if it shows any signs of motion while the drive clutch control is still disengaged, shut the engine off immediately.

- Make sure that the drive clutch control is adjusted so the drive belt is as loose as possible.
- Move throttle control lever all the way back to the "rabbit" position.
- Push primer three times. Wait about two seconds between each push. In cold weather around 55° F or below, prime five times. Do not prime to restart a warm engine after a short shutdown.
- Standing behind the mower, depress the blade control handle and hold it against the upper handle.
- Grasp starter handle and pull rope out slowly until engine reaches the start of compression cycle (rope will pull slightly harder at this point). Let the rope rewind slowly. Pull rope with a rapid, continuous, full arm stroke. Keeping a firm grip on the starter handle, let the rope rewind slowly.

## Stopping Engine

- Release blade control handle to stop the engine and the blade.
- Disconnect spark plug wire and move away from spark plug to prevent accidental starting.

## Using Your Lawn Mower

- **Do not** operate the mower without the mulching cover or the grasscatcher bag properly installed.
- Be sure that the lawn is clear of stones, sticks, wire, or other objects which could damage lawn mower or engine. Such objects could be accidentally thrown by the mower in any direction and cause serious personal injury to the operator and others.
- *For best results, do not cut wet grass* because it tends to stick to the underside of the mower, preventing proper discharge of grass clippings, and could cause you to slip and fall. New grass, thick grass or wet grass may require a narrower cut.
- For a *healthy lawn*, always cut off one-third or less of the total length of the grass. Lawn should be trimmed in fall as long as there is growth.
- Always operate your mower with the engine in the full throttle (rabbit) position for the most effective mulching or bagging of the cut grass.



**WARNING:** If you strike a foreign object, stop the engine. Remove spark plug wire from spark plug, thoroughly inspect the mower for any damage. Repair the damage before restarting and operating the mower. Extensive vibration of the mower during operation is an indication of damage. The unit should be promptly inspected and repaired.

## Bagging Grass Clippings

You can use the grasscatcher bag to collect clippings while you are operating the mower. Attach the grasscatcher following instructions on page 9 of this manual. The grass clippings will automatically collect in the bag as you run the mower. Operate the mower till the grass bag is full. Do NOT allow the bag to overfill with grass clippings. Stop the engine completely by releasing the control handle. Make sure that the unit has come to a complete stop. To empty the grass bag proceed as follows:

- Lift discharge door and pull grass bag up and away from the mower to dispose of the grass clippings See Figure 9.

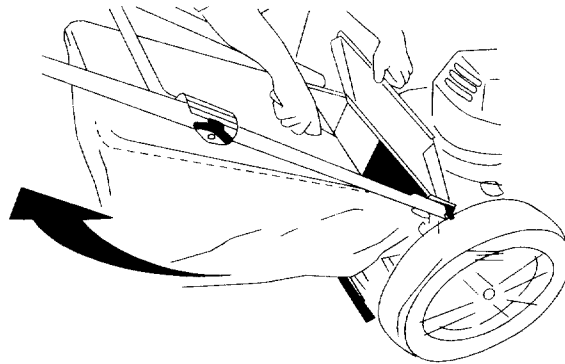

FIGURE 9

## Adjusting Cutting Height

Refer to height adjustments section of this manual on page 16 for instruction on how to adjust the cutting height and the handle height.

- For best results in mowing, keep the cutting height position high until it is determined which height is best for your lawn.

---

## SECTION 8: MAINTENANCE



**WARNING:** Always stop the engine and disconnect the spark plug wire before performing any maintenance work or adjustments on your lawn mower.

### Cleaning Mower

The underside of the mower deck should be cleaned after each use to prevent any build-up of grass clippings, leaves, dirt, or other debris. If this debris is allowed to accumulate, it will result in rust and corrosion.

- Disconnect spark plug wire.
- Drain the gasoline from the lawn mower, or place a piece of plastic under the gas cap.
- Tip the mower so that it rests on the housing. Keep the side with the air cleaner facing UP. Hold the mower firmly.
- Scrape and clean the underside of the deck with a suitable tool. Do NOT spray with water.
- Put the mower back on its wheels on the ground. If you had put plastic under the gas cap, make sure to remove it now.



**WARNING:** Never tip the mower more than 90 degrees in any direction and do not leave the mower tipped for any length of time. Oil can drain into the upper part of the engine causing a starting problem.

## Engine Maintenance

- A list of key maintenance jobs required for good performance by the mower is given below. Follow the accompanying engine manual for detailed list and instructions.
- Change engine oil after the first two operating hours and every 25 operating hours thereafter. Check the oil level before starting the engine every time.
- Service foam filter in the air cleaner every 25 hours of use and replace the paper filter component every 100 hours. You may have to service the air filter more frequently if you are operating the mower under extremely dusty conditions.
- Clean the engine periodically. Remove dirt and debris with a cloth or brush. Do not use a garden hose to clean mower unless the muffler, air filter and the carburetor are covered to keep water out. Water in engine can shorten engine life.
- Clean the spark plug and reset the gap to .030" at least once a season or every 50 hours of operation. Spark plug replacement is recommended at the start of each season. Refer to the engine manual for correct spark plug type.
- Inspect muffler periodically, and replace if necessary. Damaged mufflers or spark arresters can create a fire hazard. Make sure to avoid muffler and surrounding areas while the mower engine is hot because temperature of these areas of the engine may exceed 150° F.

## Lubrication

### Wheels

- Lubricate the wheels and bearings, if so equipped, at least once a season with light oil or engine oil. Also, if the wheels are removed for any reason, lubricate the surface of the axle bolt and the inner surface of the wheel with light oil.

### Chute Deflector & Rear Discharge Door

- Lubricate the torsion spring and the pivot point on each end of the chute deflector and the rear discharge door using a light oil. This will prevent rusting and ensure that the deflector, which is a safety device, can always work properly.

### Engine

- Follow the engine manual instructions and recommended schedule for lubricating engine components.

### Transmission

- The transmission is pre-lubricated and sealed at the factory and does not require lubrication on a regular basis as part of maintenance. However, if you disassemble the transmission for any reason, refill with two ounces of Alvania grease (part # 737-0168) as part of reassembly.

### Pivot Points

- Lubricate the pivot points on the blade control handle, brake cable and the cutting height adjustment lever at least once a season with light oil. The blade control handle must operate freely in both directions. The cutting height adjustment lever should be able to move easily.

---

## SECTION 9: SERVICE & ADJUSTMENTS

### Blade Care

Periodically inspect the blade adapter and pulley for cracks, especially if you strike a foreign object. Replace when necessary.



**WARNING:** When removing the cutting blade for sharpening or replacement, protect hands by using heavy gloves or a thick rag to grasp the cutting blade.

- Disconnect spark plug wire from spark plug.
- Turn mower on its side making sure that the air filter and the carburetor are up.

## To Remove Blade

- Remove the bolt and bell washer which hold the blade-pulley assembly to the engine crankshaft. See Figure 10. Remove the assembly from the crankshaft.
- Remove the two bolts and lock nuts from the blade assembly.
- Remove the blade from the blade adapter and pulley.

## To Replace Blade:

- Before reinstalling the blade-pulley assembly to the unit, lubricate the engine crankshaft and the inner surface of the blade adapter with light oil or engine oil.
- Also lubricate the bolt holes, bolt and the inner surface of the nuts.
- Install the blade adapter on the pulley with the “star” away from the pulley. See Figure 10.

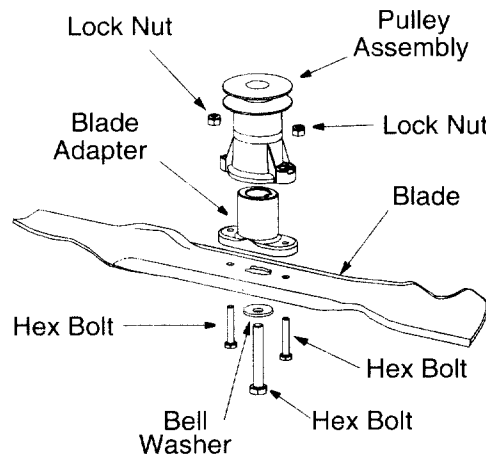

FIGURE 10

- Place the new blade on the blade adapter with the side marked bottom (or with part number) facing away from the adapter.
- Secure the blade to the assembly with two hex bolts and lock nuts. Tighten the hex bolts to the recommended torque. Refer to ‘Blade Mounting Torque’ section on this page.
- Install the blade assembly on the crankshaft. Secure with the hex bolt and bell washer (cupped side of washer to blade) and tighten to the recommended torque. Refer to ‘Blade Mounting Torque’ section on this page.

**IMPORTANT:** The bolt used to secure the blade to the engine is specially heat-treated. **Do not substitute.** To order replacement bolt, refer to the parts list in the back of of this manual.



**WARNING:** To ensure safe operation of your unit, all nuts and bolts must be checked periodically for correct tightness.

## To Sharpen Blade:

- The blade can be sharpened with a file or on a grinding wheel. Do not attempt to sharpen the blade while it is still on the mower.
- Follow the original angle of grind as a guide. Make sure that each cutting edge receives an equal amount of grinding to prevent an unbalanced blade.

**NOTE:** An unbalanced blade will cause excessive vibration when rotating at high speeds, may cause damage to the mower and could break, causing personal injury. Test the blade by balancing it on a round shaft screwdriver or a blade balancer.

- If the blade is not balanced, remove metal from the heavy side until it balances evenly.

## Blade Mounting Torque:

Blade adapter bolts: 120 in.lbs. minimum, 150 in.lbs. maximum.

Center bolt: 450 in.lbs. minimum, 600 in.lbs. maximum.

## Replacing Drive Belt

- Remove the two shoulder screws from on top of the deck which secures the front drive cover to the mower deck. See Figure 11.
- Remove the front drive cover from the unit by lightly pressing inward on the sides of the front drive cover. This will release the tabs that secure the front drive cover to the height adjuster brackets.
- Remove the idler from the idler bracket using 7/16" wrench and socket. See Figure 11.
- Remove the belt from the transmission pulley as shown in Figure 11.

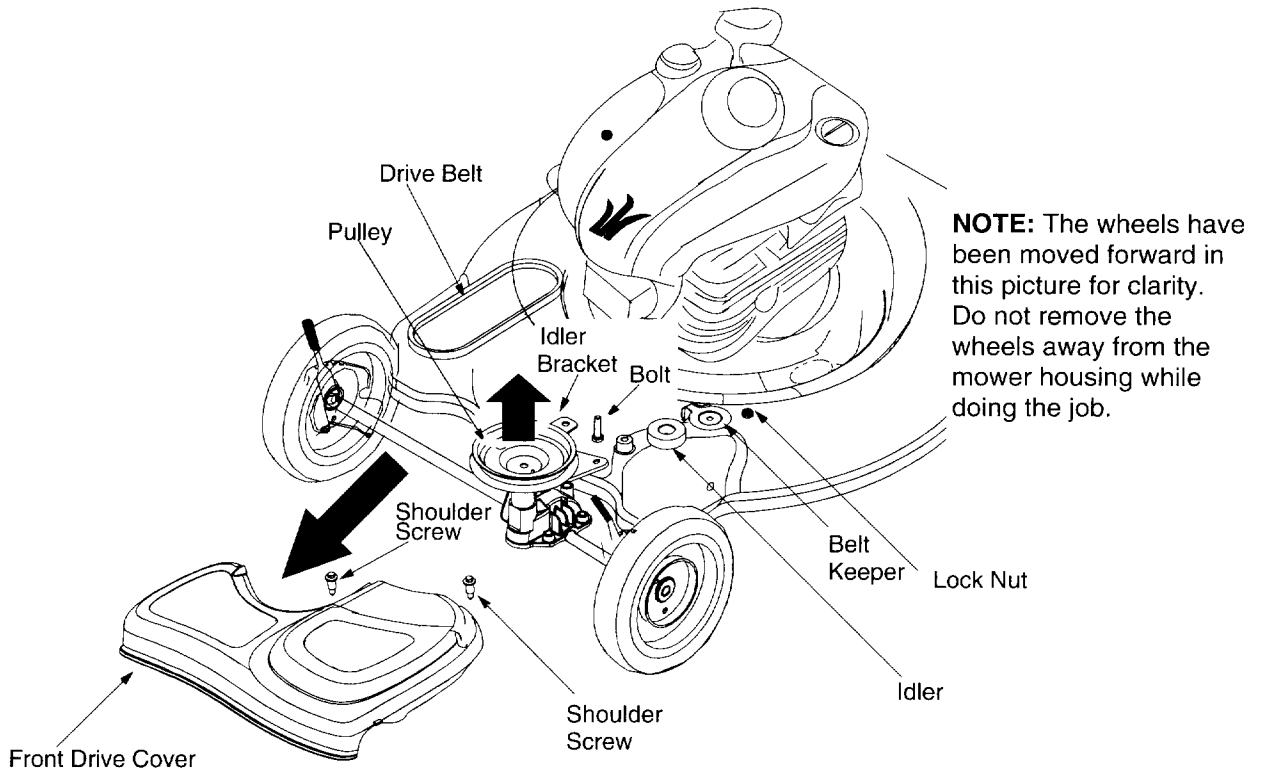

FIGURE 11

- Lift and stabilize the front of the deck.
- Loosen the center hex bolt and lower the blade and engine pulley until there is adequate clearance to move the belt past the belt keeper.
- Remove the belt from the engine pulley and around the blade. See Figure 12.
- Reassemble in reverse order with new belt (part # 754-0465). **NOTE:** Begin idler reassembly by inserting bolt up through the idler bracket hole. Adjust the drive clutch following instructions on page 17.



- **IMPORTANT:** Torque center hex bolt to between 450 and 600 in. lbs.

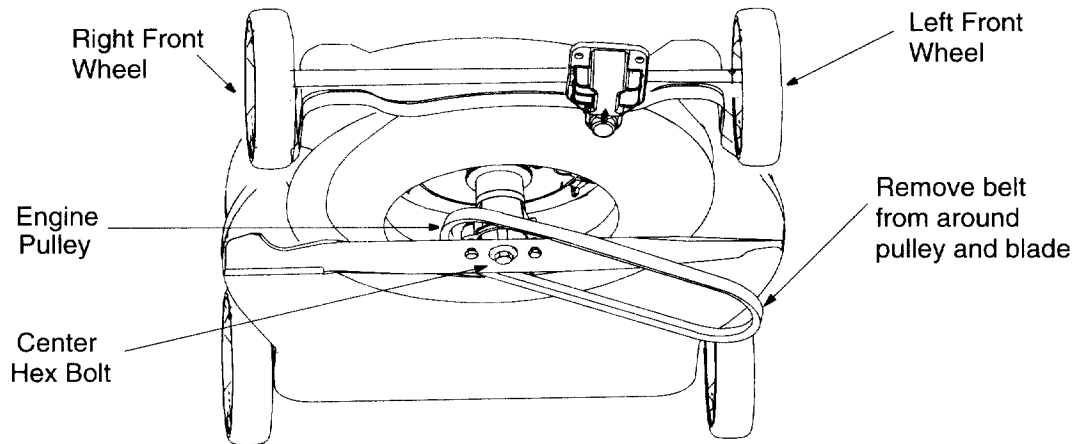

FIGURE 12

### Adjusting Drive Clutch Control

- The drive clutch adjustment wheel is located on the drive clutch control handle housing and is used to tighten or loosen tension on the drive cable. Perform this adjustment if the following exists.
  - a. The mower does not propel itself with the drive clutch engaged.
  - b. The mower's drive wheels hesitate with the drive clutch engaged.
- To resolve the above problems, rotate the adjustment wheel with your fingers: clockwise to tighten the cable, and counter-clockwise to loosen the cable. See Figure 13 .

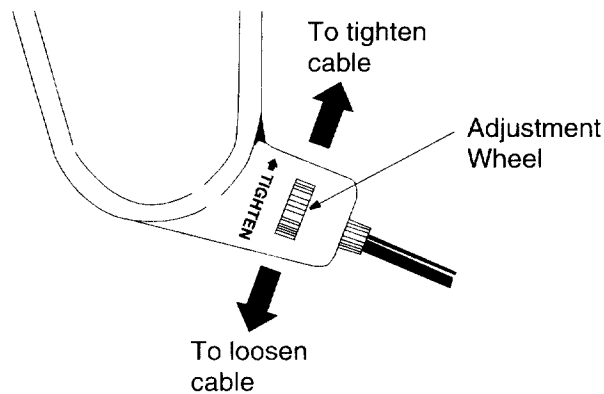

FIGURE 13

### Adjusting Handle Height

Your mower is shipped with the handle in the higher height position. To lower the handle height, proceed as follows.

- Remove the starter rope from the rope guide.
- Remove the upper handle by removing the hand knobs and carriage bolts. Lay the upper handle out of the way, being careful not to bend or kink the cables.
- Remove the hairpin clips from the weld pins on the handle brackets. Refer to Figure 3. Press out on the legs of the lower handle. Remove lower handle from the mower.

- Turn the lower handle around so the notch on the bottom of the lower handle is facing forward as shown in Figure 14A. Reassemble, placing the bottom holes in the handle over the weld pins in the handle mounting bracket.

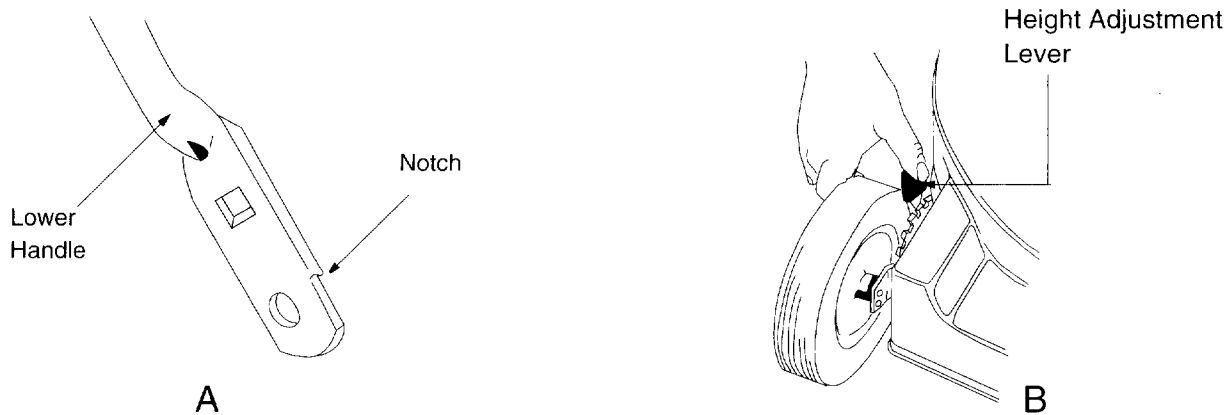

FIGURE 14

- Reassemble the upper handle to the lower handle.
- Place the hairpin clips in the inner holes of the weld pins and attach the starter rope as instructed in the Assembly section.

### Adjusting Cutting Height

**IMPORTANT:** All wheels must be placed in the same relative position. For rough or uneven lawns, move the height adjustment lever to a higher position. This will help stop scalping of the grass.

An adjusting plate and thumb lever at each wheel position provides cutting height adjustment. Each adjusting plate has nine height positions. Height of cut will be changed when the thumb lever is moved from one hole to another.

- Simply depress the lever towards the wheel and move the lever assembly to desired position. See Figure 14B.
- For rough or uneven lawns, move the height adjustment handles to higher cutting height position.

### Adjusting Engine Throttle Speed

See page 11 of this manual for instructions on adjusting the engine throttle speed.

### Adjusting Carburetor

If the engine is running rough, minor adjustments to the carburetor may be required to compensate for differences in fuel, temperature, altitude and load. **NOTE:** A dirty air cleaner may cause an engine to run rough too. So make sure that the air cleaner is clean and attached to the carburetor *before* deciding to adjust the carburetor.

To adjust the carburetor, please follow the recommendations and instructions on carburetor adjustment in the engine manual.



**WARNING:** If any adjustments are made to the engine (e.g. carburetor) while the engine is running, keep clear of all moving parts. Be careful of heated surfaces like the muffler.

---

## SECTION 10: OFF-SEASON STORAGE

Prepare your lawn mower for storage at the end of the season or **if the unit will not be used for 30 days** or more. Store the mower in a **clean, dry area**.

### Mower

- Clean underside of the mower following instructions in the Maintenance section of this manual.
- Lubricate mower as instructed on page 14 of this manual.
- You can fold your mower's handle for convenient storage: Remove the starter rope from the rope guide; loosen the two hand knobs on the sides of the handle, and let the upper handle fold down to the rear. Move the hairpin clips to the outer hole in the weld pins on the handle mounting brackets. Spread the sides of the lower handle, and push it forward and down.

- Inspect and replace/sharpen blade, if required. Refer to the Maintenance section of this manual for blade care instructions.

**Engine**

- Follow recommendations in the accompanying engine manual for off-season storage of the engine.
- Change oil if it has not been changed in the last three months. For instructions on how to change oil, refer to the engine manual.
- Clean engine and remove any grass clippings, dirt, and debris from the cooling fins, air intake screen, levers, linkage and the exterior of the engine.

**Other**

- Do not store gasoline from one season to another.
- Replace your gasoline can if it starts to rust. Rust and/or dirt in the gasoline will cause problems. Store unit in a clean, dry area. Do not store next to corrosive materials, such as fertilizer.

**NOTE:** If storing in an unventilated or metal storage shed, be certain to rustproof the equipment by coating with a light oil or silicone.

---

**SECTION 11: TROUBLE-SHOOTING GUIDE**

<b>PROBLEM</b>	<b>POSSIBLE CAUSE</b>	<b>CORRECTIVE ACTION</b>
Engine fails to start	1. Blade control handle disengaged 2. Spark plug wire disconnected 3. Throttle control lever not in starting position 4. Fuel tank empty, or stale fuel 5. Blocked fuel line 6. Faulty spark plug 7. Engine flooded	1. Engage blade control handle 2. Connect wire to spark plug 3. Move throttle lever to correct position 4. Fill up tank with fresh gasoline 5. Clean fuel line 6. Clean, adjust gap, or replace 7. Crank engine with throttle in FAST
Engine runs erratic	1. Spark plug wire loose 2. Blocked fuel line or stale fuel  3. Vent in gas cap plugged 4. Water or dirt in fuel system 5. Dirty air cleaner	1. Connect and tighten spark plug wire. 2. Clean fuel line, fill tank with clean, fresh gasoline. 3. Clear vent. 4. Drain fuel tank. Refill with fresh fuel. 5. Clean air cleaner. Refer to engine manual.
Engine overheats	1. Engine oil level low 2. Air flow restricted	1. Fill crankcase with proper oil. 2. Clean lawn mower engine.
Occasional skip (hesitates) at high speed	1. Spark plug gap too close	1. Adjust gap to .030 inches.
Idles poorly	1. Spark plug fouled, faulty, or gap too wide  2. Dirty air cleaner	1. Reset gap to .030 inches or replace spark plug. 2. Clean air cleaner.
Excessive vibration	1. Cutting blade loose or unbalanced  2. Bent cutting blade 3. Bent engine crankshaft	1. Tighten blade and adapter, balance blade. 2. Replace blade. 3. Contact your nearest service center
Mower will not mulch grass	1. Engine speed too low 2. Wet grass 3. Excessively high grass  4. Dull blade	1. Move throttle lever to FAST position. 2. Wait until grass is dry to cut. 3. Mow once at a high cutting height, then mow again at desired height. 4. Sharpen or replace blade.
Uneven cut	1. Wheels not in same height position  2. Dull blade	1. Reposition all wheels at same height. 2. Sharpen or replace blade.

# Model 559K

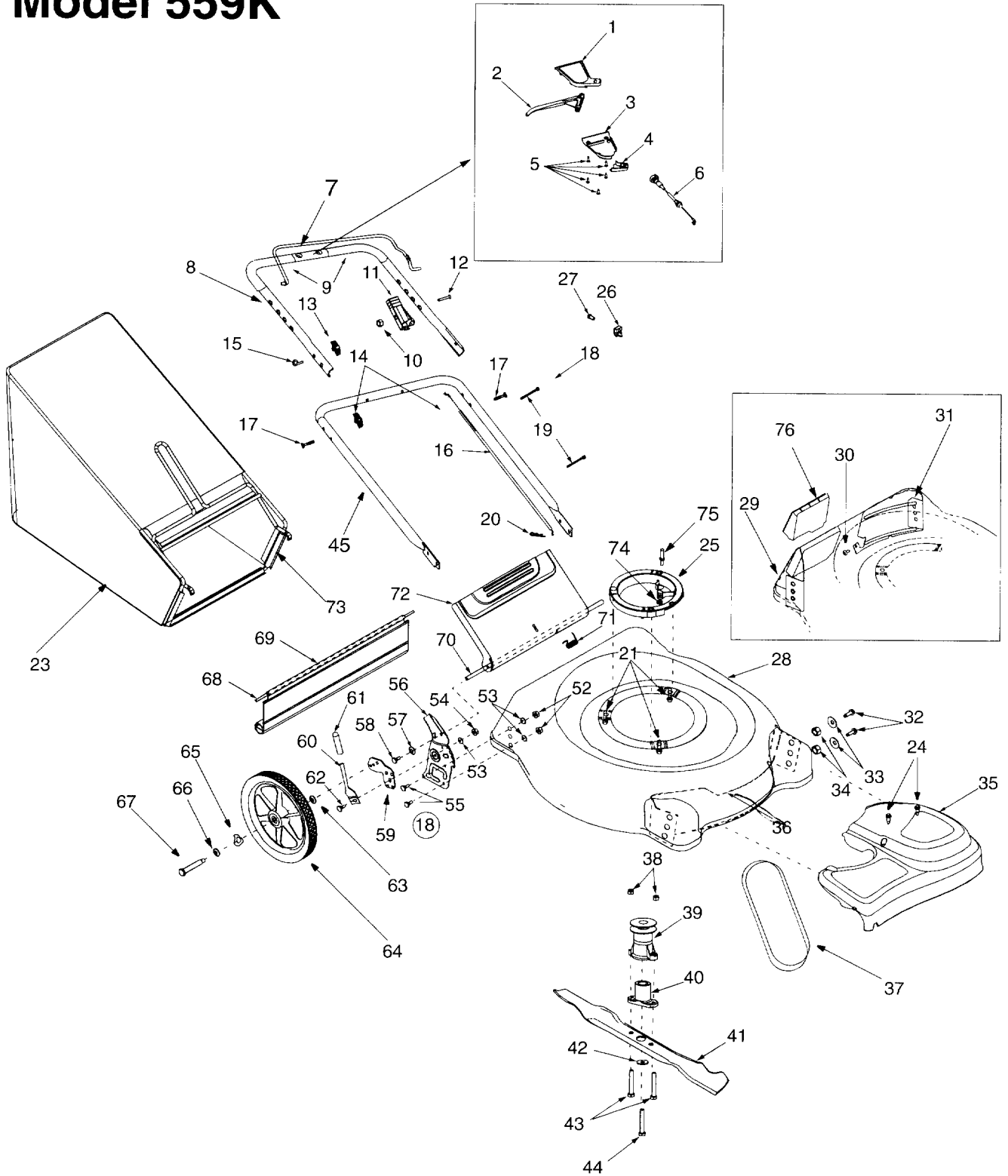

# Model 559K

Ref. No	Part No.	Description	Ref. No	Part No.	Description
1.	731-1057	Upper Drive Cover	37.	754-0465	V-Belt, 3/8 x 35.68"
2.	731-0620	Drive Lever	38.	712-0324	Hex Nut 1/4-20
3.	731-1058	Lower Drive Cover	39.	756-1146	Drive Pulley
4.	731-1059	Mounting Cap	40.	748-0411	Blade Adapter
5.	710-0841	Screw # 10-12 x .75	41.	742-0741	21" Mulching Blade
6.	746-0960	Drive Cable	42.	736-0452	Flat Washer .516 x 1.5 x .134
7.	747-0824	Control Lever	43.	710-0606	Hex Screw 1/4-20 x 1.50
8.	749-0439B	Upper Handle (Incl. Ref. No. 9)	44.	710-1257	Hex Screw 3/8-24 x 2.50
9.	720-0294	Foam Grip, 9"	45.	749-0907A	Lower Handle
10.	712-0234	Hex Lock Nut, 1/4-20	52.	712-0798	Hex Nut 3/8-16
11.	746-0883	Throttle Housing	53.	736-0356	Bell Washer .39 I.D. x 1.38 O.D.
12.	710-1270	Oval C-Sunk Screw 1/4-20 x 1.31	54.	712-3005	Hex Flange Lock Nut 3/8-16
13.	720-0279	Handle Knob	55.	710-0896	Hex Scr. w/Washer 1/4-14 x .625
14.	720-0276	Handle Knob	56.	682-3056A	RH Handle Bracket
15.	710-1205	Eye Bolt		682-3057A	LH Handle Bracket (not shown)
16.	746-0550	Control Cable, 39"	57.	736-0270	Bell Washer .265 x .75 x .062
17.	710-1174	Carriage Bolt 5/16-18 x 2.0	58.	710-0599	Hex Screw TT 1/4-20 x .500
18.	682-3058	RH Bracket Ass'y	59.	17488A	RH Pivot Bar
		(Incl. Ref. 54, 56, 59, 60 & 62)		17489A	LH Pivot Bar (not shown)
	682-3059	LH Bracket Ass'y (Not Shown)	60.	732-0866	Height Adj. Lever
19.	726-0240	Cable Tie	61.	720-0312	Foam Grip
20.	714-0104	Cotter Pin	62.	738-0507B	Shoulder Scr .500 Dia. x .434
21.	710-1007	Self-tapping Screw	63.	736-0105	Washer .401 x .870 x .063
23.	664-0085	Grassbag w/ logo	64.	734-1860	Wheel, 14 x 2 Yellow (Link Trd.)
24.	7510042824	Screw # 12 x .457	65.	736-0182	Spring Washer .50 I.D. x 1.0 O.D.
25.	631-0075	Engine Spacer	66.	736-0456	Flat Washer .510 x 1.373 x .04
26.	751B213146	Clamp Casing	67.	738-0481	Shoulder Screw
27.	710-1237	Hex Screw TT #10-32 x .625	68.	732-0700	Wire
28.	782-0080	21" Rear Discharge Deck	69.	731-1236	Rear Trailing Shield
29.	782-5004	RH Rear Baffle	70.	747-0996	Pivot Rod
30.	710-1017	Screw AB: 1/4-14: .625	71.	732-0809	Torsion Spring
31.	782-5003	LH Rear Baffle	72.	782-7599A	Rear Discharge Door
32.	710-0216	Hex Screw 3/8-16 x .75	73.	747-0995A	Grasscatcher Frame
33.	736-0331	Bell Washer .39 x 1.13 x .062	74.	712-0271	Hex Nut
34.	712-0798	Hex Nut 3/8-16	75.	711-1293	Screw
35.	731-1937	Transmission Cover (Yellow)	76.	782-5007	Plastic Mulching Baffle
36.	782-5002	Front Baffle			

**NOTE:** For **painted parts**, please refer to the list of color codes below. Please add the applicable color code, wherever needed, to the part number to order a replacement part. For instance, if a part numbered 700-xxxx is painted Yard-Man Green, the part number to order would be 700-xxxx-0665.

Yard-Man Green: 0665  
 Yard-Man Yellow: 0674  
 Powder Black: 0637

# Model 559K

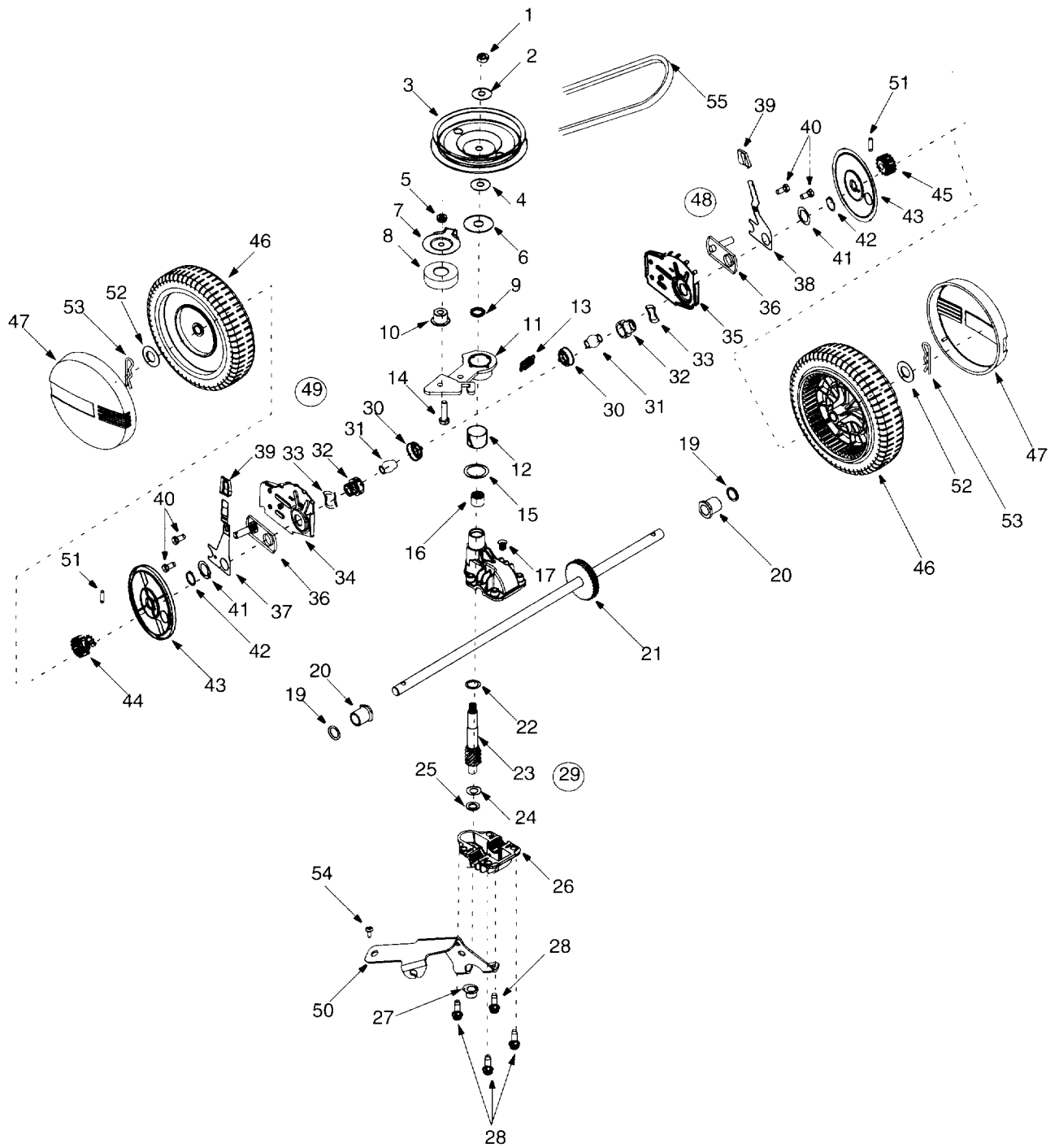

# Model 559K

Ref. No	Part No.	Description	Ref. No	Part No.	Description
1.	712-3025	Hex Jam Nut 5/16-24	30.	732-0708	Bearing Retainer
2.	736-0425	Bell Washer .325 x .930 x .045	31.	741-0604	Bearing Sleeve .50 I.D.
3.	756-1042	Pulley, 3.82 x .313 x .68	32.	748-0355	Bearing Support
4.	736-0425	Bell Washer .325 x .930 x .045	33.	736-0447	Wave Washer 1.5 x 1.0 x .029
5.	712-0896	Lock Nut 1/4-28	34.	782-0512B	RH Height Adj. Plate
6.	736-0406	Flat Washer .442 x 1.38 x .060	35.	782-0511A	LH Height Adj. Plate
7.	782-7598	Belt Keeper	36.	682-0509	Pivot Plate Assembly
8.	741-0124	Ball Bearing	37.	732-0706	RH Front Lever
9.	721-0457	Oil Seal	38.	732-0707	LH Front Lever
10.	750-1050	Flange Spacer	39.	720-0190	Knob
11.	682-0028	Idler Bracket Assembly	40.	710-0216	Hex Cap Screw 3/8-16 x .75
12.	741-0682A	Bearing Sleeve	41.	736-0474	Washer DD 1.5" O.D.
13.	732-0849A	Flat Washer .504 x .700 x .030	42.	716-0102	Snap Ring 1.0 dia.
14.	710-0299	Hex Cap Screw 1/4-28 x 1.00	43.	782-7551	Wheel Dust Cap
15.	736-0570	Flat Washer .865 x 1.145 x .030	44.	717-1534	Gear 14T RH FWD
16.	741-0699	Needle Bearing .438 x .625 x .500	45.	717-1533	Gear 14T LH FWD
17.	721-0325	Plug 1/4 x .437	46.	734-1866	Wheel, 8x2 Yellow (Link Trd.)
18.	618-0300A	Upper Housing		734-1870	Wheel, 8x2 Yellow (Bar Trd.)
19.	721-0329	Oil Seal .500 x .687 x .094	47.	731-1426	Hubcap: Yellow
20.	741-0673	Flange Bearing	48.	682-0512A	RH Height Adj. Complete
21.	611-0105	Output Shaft	49.	682-0511A	LH Height Adj. Complete
22.	736-0520	Flat Washer .504 x .700 x .030	50.	682-0030	Cable Idler Bracket
23.	717-1492	Pinion Shaft 10T	51.	715-0221	Dowel Pin
24.	736-0314	Thrust Washer .375 x .70 x .030	52.	736-3013	Flat Washer 1/2 x 1.00 x .063
25.	736-0569	Thrust Washer .388 x .625 x .062	53.	714-0101	Cotter Pin .08 x 1.42
26.	618-0299A	Lower Housing	54.	738-1002	Screw
27.	741-0672	Flange Bearing .378 x .531 x .370	55.	754-0465	Belt
28.	710-1276	Hex Screw w/Washer 1/4-20 x .750			
29.	618-0298A	Transmission Assembly (Includes Ref. # 1to Ref. #30)			

# MANUFACTURER'S LIMITED WARRANTY FOR:



For TWO YEARS from the date of retail purchase within the United States of America, its possessions and territories, MTD PRODUCTS INC will, at its option, repair or replace, for the original purchaser, free of charge, any part or parts found to be defective in material or workmanship. This warranty covers units which have been operated and maintained in accordance with the operating instructions furnished with the unit, and which have not been subject to misuse, abuse, commercial use, neglect, accident, improper maintenance or alteration.

Normal wear parts or components thereof are subject to separate terms as noted below in the "No Fault Ninety Day Consumer Warranty" clause.

All normal wear part failures will be covered on this product for a period of 90 days regardless of cause. After 90 days, but within the two year period, normal wear parts failures will be covered ONLY IF caused by defects in material or workmanship of OTHER component parts. Normal wear parts are defined as batteries\*, belts, blades, blade adapters, grass bags, rider deck wheels, seats, snow thrower skid shoes, shave plates and tires.

**How to obtain service:** Warranty service is available, with proof of purchase, through your local authorized service dealer. To locate the dealer in your area, please check the yellow pages or contact the Customer Service Department of MTD PRODUCTS INC, P. O. Box 368022, Cleveland, Ohio 44136-9722.

Phone 1 (800) 800-7310. The return of a complete unit will not be accepted by the factory unless prior written permission has been extended by the Customer Service Department of MTD PRODUCTS INC.

**Transportation charges:** Transportation charges for the movement of any power equipment unit or attachment are the responsibility of the purchaser.

**Units exported out of the United States:** MTD PRODUCTS INC does not extend any warranty for

products sold or exported outside of the United States of America, its possessions and territories, except those sold through MTD PRODUCTS INC's authorized channels of export distribution.

#### **Other Warranties:**

1. The engine or component parts thereof carry separate warranties from their manufacturers. Please refer to the applicable manufacturer's warranty on these items.
2. \*Batteries are covered by a 90-day replacement warranty.
3. Log splitter pumps, valves and cylinders or component parts thereof are covered by a one year warranty.
4. All other warranties, express or implied, including any implied warranty of merchantability or fitness for a particular purpose, are hereby expressly disclaimed in their entirety.
5. The provisions as set forth in this warranty provide the sole and exclusive remedy of MTD PRODUCTS INC's obligations arising from the sales of its products. MTD PRODUCTS INC will not be liable for incidental or consequential loss or damage.

**How state law relates to this warranty:** This limited warranty gives you specific legal rights, and you may also have other rights which vary from state to state. Certain disclaimers are not allowed in some states and therefore they may not apply to you under all circumstances.

**NOTE:** This warranty does not cover routine maintenance items such as lubricants, filters, blade sharpening and tune-ups, or adjustments such as brake adjustments, clutch adjustments or deck adjustments. Nor does this warranty cover normal deterioration of the exterior finish due to use or exposure.