

Operating/Service Instructions

RIDING MOWER

IMPORTANT

SAFE OPERATION PRACTICES - RIDING MOWERS

Model No.

132-415

1. Know the controls and how to stop quickly—**READ THE OWNER'S MANUAL.**
2. Do not allow children to operate vehicle. Do not allow adults to operate it without proper instruction.
3. Do not carry passengers. **Keep children and pets a safe distance away.**
4. Clear work area of objects which might be picked up and thrown.
5. Disengage all attachment clutches and shift into neutral before attempting to start engine (motor).
6. Disengage power to attachments and stop engine (motor) before leaving operator position.
7. Disengage power to attachment(s) and stop engine (motor) before making any repairs or adjustments.
8. Disengage power to attachments when transporting or not in use.
9. Take all possible precautions when leaving vehicle unattended; such as disengaging power-take-off, lowering attachments, shifting into neutral, setting parking brake, stopping engine and removing key.
10. Do not stop or start suddenly when going uphill or downhill. Mow up and down the face of steep slopes; never across the face.
11. Reduce speed on slopes and in sharp turns to prevent tipping or loss of control. Exercise extreme caution when changing direction on slopes.
12. Stay alert for holes in terrain and other hidden hazards.
13. Use care when pulling loads or using heavy equipment.
 - A. Use only approved drawbar hitch points.
 - B. Limit loads to those you can safely control.
 - C. Do not turn sharply. Use care when backing.
 - D. Use counterweight(s) or wheel weights when suggested in owner's manual.
14. Watch out for traffic when crossing or near roadways.
15. When using any attachments never direct discharge of material toward bystanders nor allow anyone near vehicle while in operation.
16. Handle gasoline with care—it is highly flammable.
 - A. Use approved gasoline container.
 - B. Never remove cap or add gasoline to a running or hot engine or fill fuel tank indoors. Wipe up spilled gasoline.
 - C. Open doors if engine is run in garage—exhaust fumes are dangerous. Do not run engine (motor) indoors.
17. Keep vehicle and attachments in good operating condition and keep safety devices in place. Use guards as instructed in owner's manual.
18. Keep all nuts, bolts, and screws tight to be sure equipment is in safe working condition.
19. Never store equipment with gasoline in the tank inside a building where fumes may reach an open flame or spark.
20. Allow engine to cool before storing in any enclosure.
21. To reduce fire hazard keep engine free of grass, leaves or excessive grease.
22. Vehicle and attachments should be stopped and inspected for damage after striking a foreign object and the damage should be repaired before restarting and operating the equipment.
23. Do not change engine governor settings or over-speed engine.
24. When using vehicle with mower:
 - (1) Mow only in daylight or in good artificial light.
 - (2) Never make a cutting height adjustment while engine (motor) is running if operator must dismount to do so.
 - (3) Shut engine (motor) off when removing grass catcher and/or unclogging chute.
 - (4) Check blade mounting bolts for proper tightness at frequent intervals.
25. Check grass catcher bags frequently for wear or deterioration. Replace with new bags for safety protection.

ASSEMBLY

GRASS CATCHER Model No. 192-010 is available as optional equipment for the mowers shown in this manual.

WARNING

1. The mower should not be operated without the entire grass catcher or chute deflector in place.
2. The mower should not be operated without the protective shield on the rear of the deck in place.

NOTE

Under normal usage bag material is subject to wear, and should be checked periodically. Be sure any replacement bag complies with the mower manufacturer's recommendations.

For replacement bags, use only factory authorized replacement bag No. 764-121.

IMPORTANT: After striking a foreign object, stop the engine (motor). Remove wire from spark plug, thoroughly inspect the mower for any damage, and repair the damage before restarting and operating the mower.

NOTE

Reference to right-hand or left-hand side of machine is from the driver's seat facing forward.

Your mower is shipped assembled except for the steering wheel and seat.

STEERING WHEEL ASSEMBLY See figure 1.

- Step 1. Line up the hole in the steering column and the hole in the tubing and drive in the small roll pin with a hammer.

NOTE

It may be necessary to use a drift pin to line up the holes.

- Step 2. Place the end caps on the spacer.
- Step 3. Slide the spacer over the tubing until it lays flush against the steering box.
- Step 4. Align the hole in the steering wheel and tubing and drive in the large roll pin with a hammer.
- Step 5. Place the cap on the steering wheel.

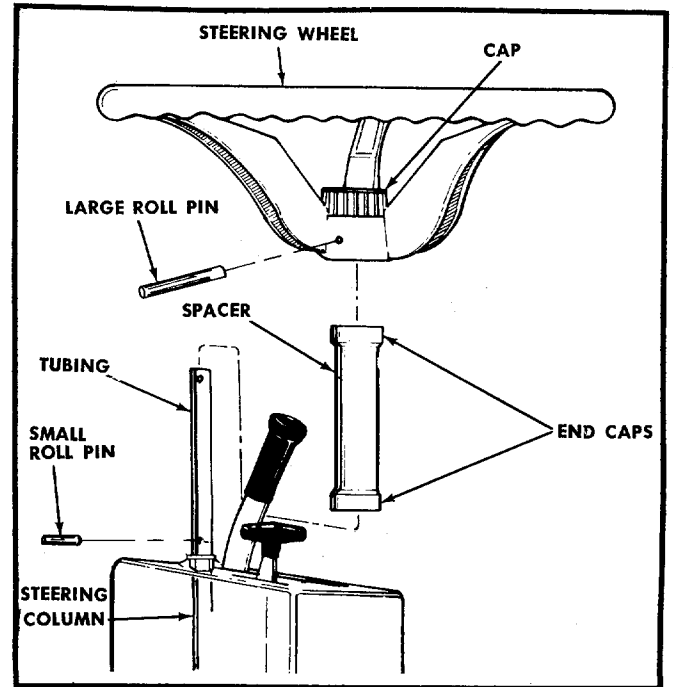

FIGURE 1. STEERING WHEEL ASSEMBLY

SEAT ASSEMBLY

- Step 1. Assemble the seat to the seat bracket with the large carriage bolt and nut. See figure 2.

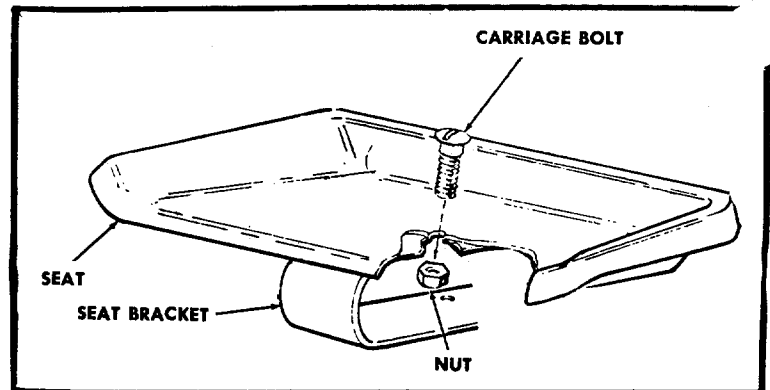

FIGURE 2. SEAT ASSEMBLY

- Step 2. Place the seat cover over the seat and tie the string on the back side. See figure 3.

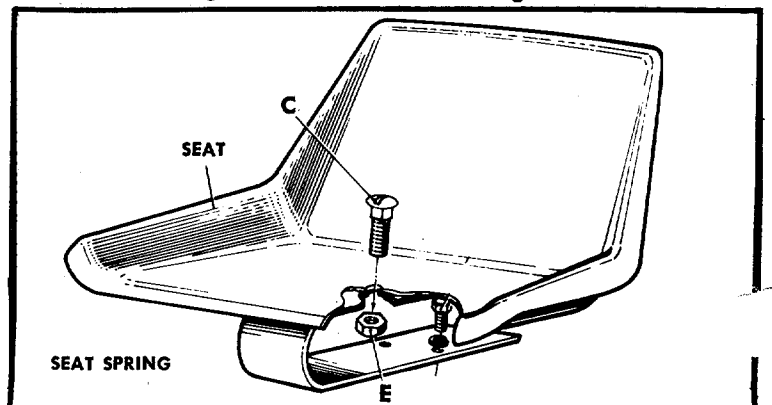

FIGURE 2A. SEAT ASSEMBLY

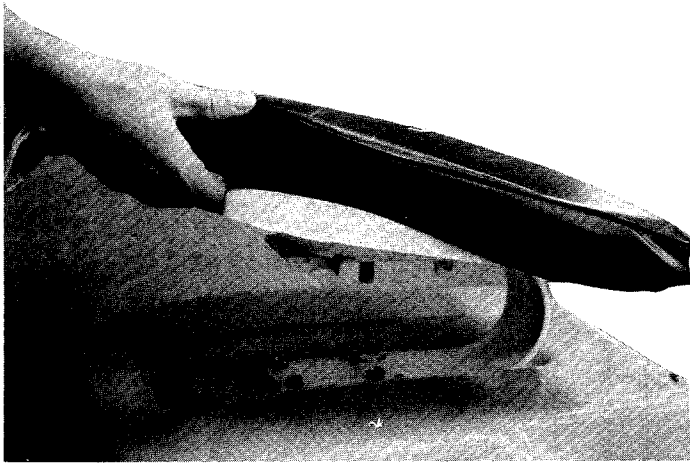

FIGURE 3. SEAT COVER ASSEMBLY

CONTROLS See figures 4 and 5.

THROTTLE CONTROL

The throttle control is used to regulate the engine speed and to activate the choke on the engine. To get the maximum efficiency on cutting, the throttle should be in the FAST position when operating the mower. Pushing the throttle all the way forward, past FAST will choke the engine.

IGNITION KEY

The key must be turned to the ON position before you pull the recoil handle to start the engine. Remove the key when the mower is not in use. Turn the key to the left to the OFF position to stop the engine.

INTERLOCKS (Not Shown)

An interlock safety switch is located on the clutch pedal and the lift and disengagement lever.

The clutch pedal must be depressed all the way down (the speed control handle can be pulled back to lock it down) and the lift and disengagement lever must be in the STOP position (forward) before the engine can be started.

On the recoil start model, the ignition will be grounded and on the electric start model, the starter will not run.

GEAR SHIFT LEVER

The gear shift lever has three positions, FORWARD, NEUTRAL and REVERSE. The clutch pedal must be depressed and the rider must not be moving when shifting gears. You may not be able to shift gears when the speed control handle is all the way back. Do not force the shift lever. Release the clutch pedal slightly to line up the shifting collar in the transmission and then try to shift.

BRAKE

To operate the brake depress the right pedal all the way down. To lock the brake in the park position, pivot the pedal forward with your foot as you depress it. It will stay in the depressed position. To release the parking brake, pivot the pedal to the rear.

LIFT AND DISENGAGEMENT LEVER

The lift and disengagement lever is used to raise and lower the cutting deck, set the cutting height, and disengage the cutting blades.

Move the lever to the left and move the lever all the way forward and lock it to disengage the blades. The lever may be set in any one of the five cutting height positions. This lever works in conjunction with the deck wheel adjusters.

DECK WHEELS

Always set both deck wheels in the same relative position. Set these wheels after you set the Lift and Disengagement Lever so they just clear the ground. This will prevent scalping the grass.

CLUTCH PEDAL

The clutch pedal on the left side when depressed reduces your ground speed and disengages the engine from the transmission when depressed all the way down. It can be held in the disengaged position by pulling the Speed Control Handle into the locked position (all the way back). To stop the mower, depress the Clutch and Brake Pedals.

SPEED CONTROL HANDLE

The Speed Control Handle can be used as a hand control for the clutch pedal and is also used to lock the clutch pedal in the disengaged position by pulling it all the way back towards the operator.

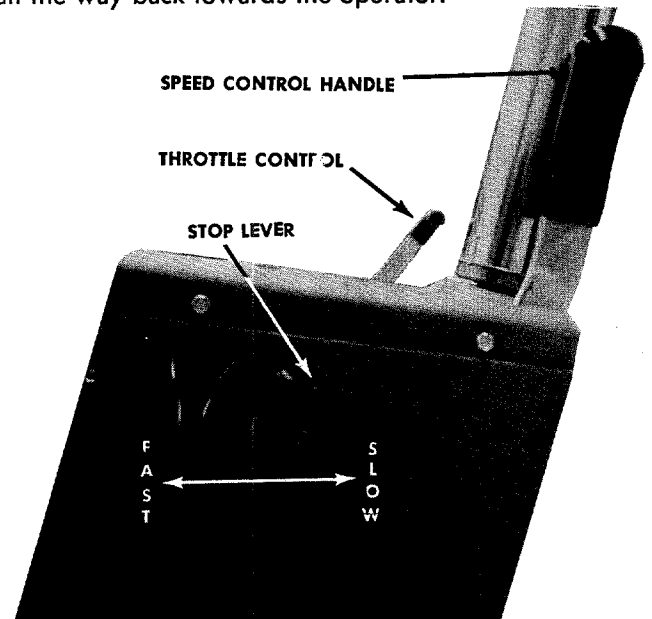

FIGURE 5. SPEED CONTROL

STOP LEVER See figure 4.

The Stop Lever allows you to regulate the maximum ground speed of the riding mower by setting the Stop Lever in any one of the five settings.

NOTE

The farther forward the Stop Lever is set, the faster your ground speed.

Depressing the clutch pedal at any time will slow you down or, if depressed all the way, will stop the mower.

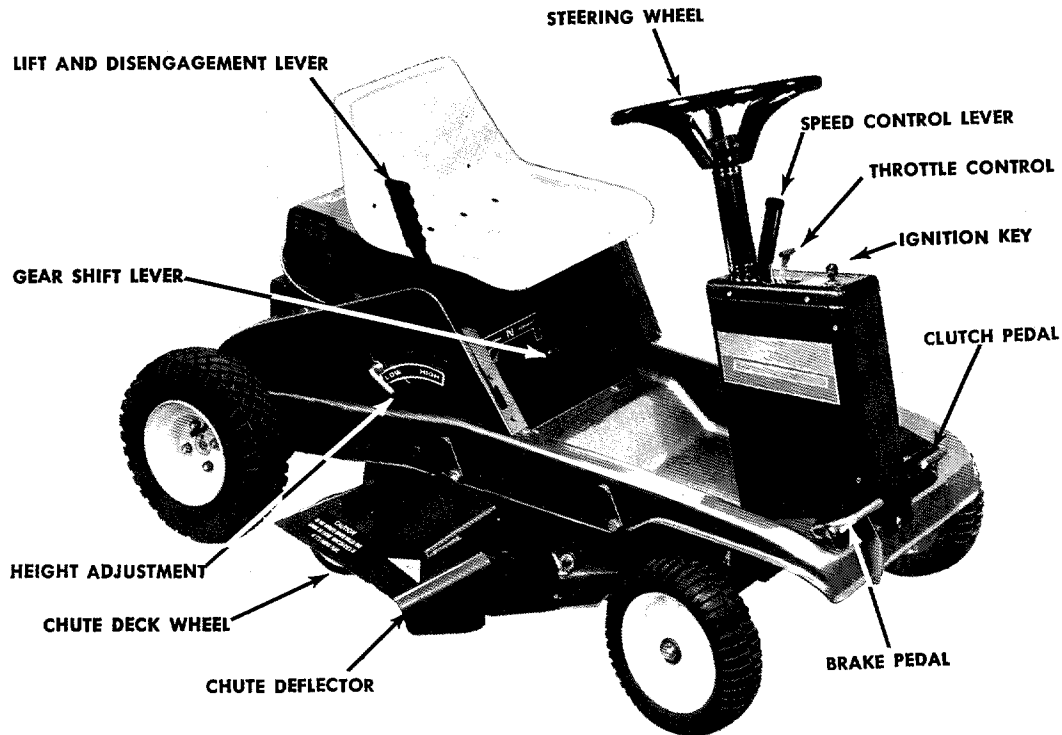

FIGURE 5. CONTROLS

OPERATING INSTRUCTIONS

CAUTION

1. Keep all shields and guards in place.
2. Before leaving operator's position:
 - Shift controls into neutral
 - Set parking brake
 - Disengage attachment drive
 - Shut off engine
 - Remove ignition key
3. Wait for all movement to stop before servicing machine.
4. Keep people and pets a safe distance away from machine.

STOPPING

Engine—Turn the ignition key to the left to the OFF position.

Rider—Depress the clutch and brake pedals.

Blades—Move the lift and disengagement lever all the way forward and lock it.

STARTING THE ENGINE

1. Be sure the crankcase is filled with oil as recommended in the engine manual and put regular gasoline in the gasoline tank.
2. Be sure the fuel shut off valve located on the carburetor is open.
3. Attach the wire to the spark plug.
4. Depress the clutch pedal and lock it down with the speed control lever.

5. Move the lift and disengagement lever forward to the disengaged position and lock it.
6. Set the throttle control lever in the CHOKE position.
7. Turn the ignition key to the ON position, twist the recoil starter handle until it is free and pull it with a quick steady motion. After the engine starts, return the recoil starter handle and twist it until it locks. See figure 6.

NOTE

If you do not do this the engine will quit running as soon as you engage the clutch or blades.



FIGURE 6. RECOIL STARTER

8. To stop the mower turn the ignition key to the OFF position and remove the key when the rider is not in use.

PUTTING THE RIDER IN MOTION

1. Advance the throttle control from $\frac{3}{4}$ to full throttle to prevent strain on the engine and to operate the cutting blades.
2. Hold the clutch pedal down with your right foot and release the speed control lever.
3. Place the gear shift lever in either the FORWARD or REVERSE position.
4. Set the stop lever in the slowest position.
5. Slowly release the clutch pedal.
6. To stop the rider, depress the clutch pedal and the brake pedal.
7. The blades can be engaged either while moving or while standing still. Move the lift and disengagement lever back slowly until the blades are running.

After you feel you can control the machine in the slower speeds, set the stop lever in a faster position. The rider will maintain the highest speed you set without you touching the controls. If you want to slow down, depress the clutch pedal until you attain the speed you want. When you remove your foot from the clutch pedal the rider will operate at the highest speed that you set on the stop lever.

MAINTENANCE AND ADJUSTMENTS

THROTTLE CONTROL See figure 7.

To Check Operation:

Remove Air Cleaner. Move remote control lever to CHOKE position. The carburetor choke should then be closed. Move the remote control lever to STOP. Control lever on carburetor should then make good contact with stop switch to short out ignition.

To Adjust

Place remote control lever on equipment in FAST (high speed) position.

Lever C on carburetor should be just touching choke arm at D. To adjust, loosen casing clamp screw A on blower housing. Move control casing B forward or backward until correct position is obtained. Tighten screw A.

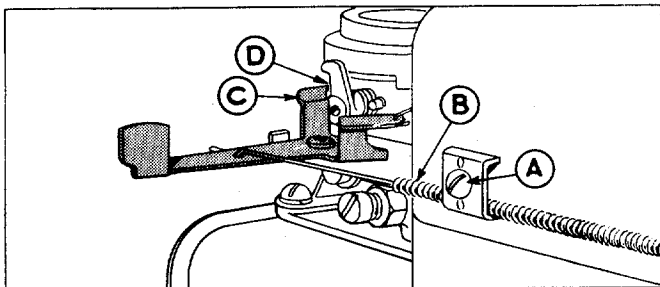

FIGURE 7. THROTTLE ADJUSTMENT

Recheck operation of controls after adjustment. Replace air cleaner.

CARBURETOR ADJUSTMENTS See figure 8.

Minor carburetor adjustments may be required to compensate for differences in fuel, temperature, altitude and load.

Initial Adjustment:

Turn needle valve clockwise to close it. Then open 2 turns. This initial adjustment will permit the engine to be started and warmed up before making final adjustment.

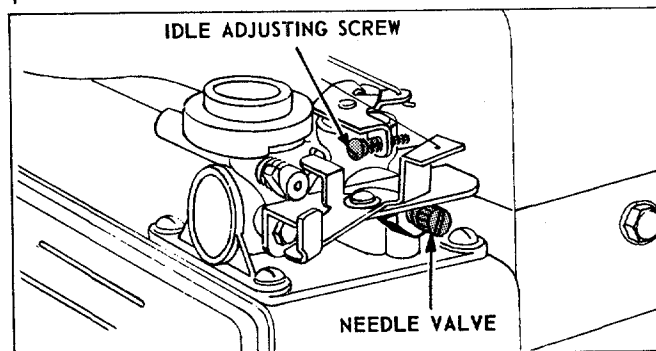

FIGURE 8. CARBURETOR ADJUSTMENT

Final Adjustment:

With engine running at normal operating speed (approximately 3000 RPM without load) turn needle valve clockwise until engine starts to lose speed (lean mixture). Then slowly turn needle valve counterclockwise past the point of smoothest operation until engine just begins to run unevenly. This mixture will give best performance under load.

To check adjustment move engine control from SLOW to FAST speed. If engine tends to stall or die out, it usually indicates that the mixture is slightly lean and it may be necessary to open the needle valve slightly to provide a richer mixture. This richer mixture may cause a slight unevenness in idling.

CHAIN ADJUSTMENT

After the first five hours of operation the initial slack should be removed from the chain. The chain should be tight enough so that it deflects approximately $\frac{1}{2}$ " when it is depressed with the thumb.

To Adjust:

The adjusting bolt is located under the frame, above the cutting deck on the right side of the mower.

Turn the adjusting bolt clockwise with an open end wrench until the chain reaches the proper tension.

NOTE

If the transmission mounting plate will not slide forward to adjust the chain tension, it may be necessary to loosen the four nuts mounting the transmission to the frame.

BRAKE ADJUSTMENT See figure 9.

To adjust the brake, tighten the locknut one half turn and then test the brakes. Repeat if necessary. The brake is located by the right rear wheel inside the frame.

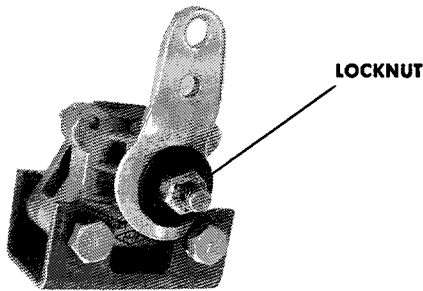

FIGURE 9. BRAKE ADJUSTMENT

BLADES

WARNING

Disconnect the spark plug wire and remove the ignition key before removing the blades.

Sharp and balanced blades are essential for efficient mowing and long mower and engine life. When sharpening blades, file equal amounts of metal from each side. The blades should be balanced before they are reinstalled. An unbalanced blade will cause excessive vibration and undue wear on the mower and the engine. When reassembling, all parts must be installed in the proper order and fastened securely. Remove the 3/8" bolt and lockwasher. Pull the blade and adapter off the mower deck. To remove the adapter from the blade, remove the two 5/16" bolts, lockwashers and nuts. See figure 10.

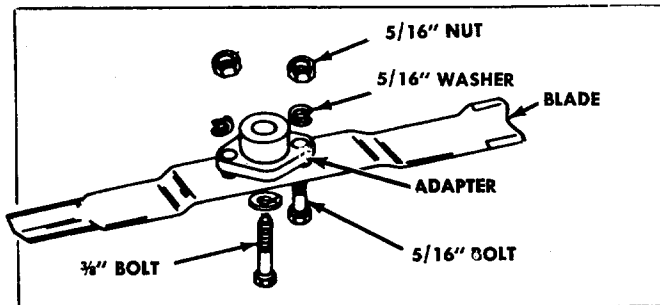

FIGURE 10. BLADE REMOVAL

MOWER DECK

The underside of the mower deck should be cleaned after each period of use as grass clippings, leaves, dirt and other matter will accumulate. This accumulation of grass clippings, etc., is undesirable as it will invite rust and corrosion and may cause an uneven discharge of grass clippings at the next mowing.

The deck may be cleaned by tilting the mower on its front wheels until the frame and the steering wheel supports the entire unit. Scrape clean with a suitable tool or by washing with a stream of water from a garden hose. Be sure to disconnect the spark plug wire and ground it while performing this maintenance.

BELT REMOVAL See figure 11.

To Remove the Deck Belt:

- Step 1. Put the Lift and Disengagement Lever into the ENGAGED position.
- Step 2. Remove the keeper on the R. H. side of the engine belt guard.
- Step 3. Remove the hex nut holding the idler on the engine belt guard.
- Step 4. Remove the two keepers on the deck pulley.
- Step 5. Remove the shoulder bolt on the deck pulley.
- Step 6. Move the Lift and Disengagement Lever into the DISENGAGED position.
- Step 7. Remove the belt and reassemble with a new belt.

NOTE

When assembling the idler be sure the longer shoulder is up so the idler turns free.

To Remove the Variable Speed Belts:

- Step 1. Put the Lift and Disengagement Lever into the ENGAGED position.
- Step 2. Put the Parking Brake ON.
- Step 3. Remove the keeper on the R.H. side of the engine belt guard.
- Step 4. Remove the hex nut holding the idler on the engine belt guard.
- Step 5. Put the Lift and Disengagement Lever into the DISENGAGED position and remove the deck belt from the engine pulley.
- Step 6. Remove the hex nut and lockwasher holding the Variable Speed Pulley.
- Step 7. Remove the hex nut and lockwasher holding the transmission pulley in place.
- Step 8. Remove the pulleys and belts at the same time.
- Step 9. Reassemble with the new belts.

NOTE

When assembling the idler be sure the longer shoulder is up so the idler turns free.

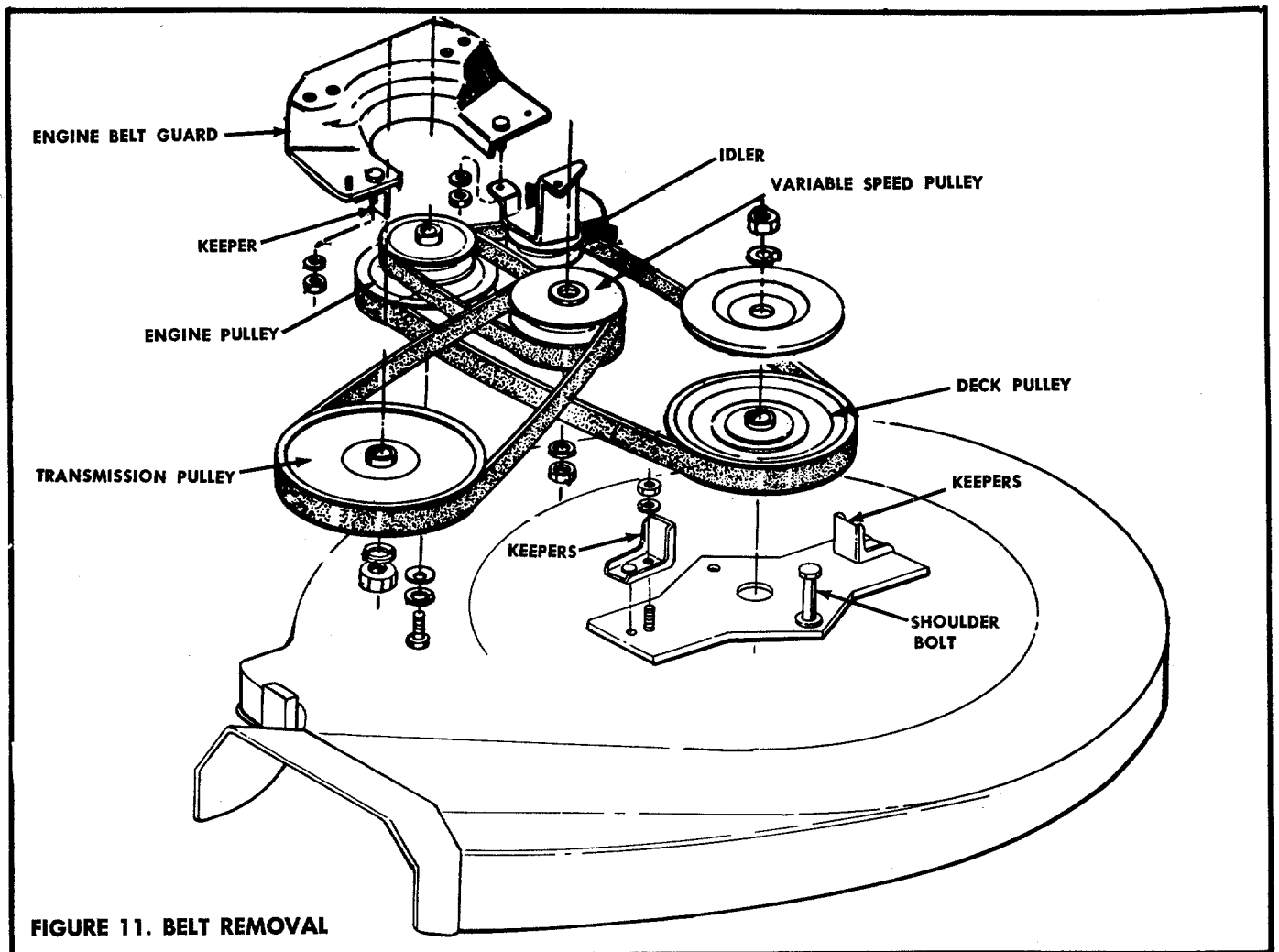

FIGURE 11. BELT REMOVAL

LUBRICATION

1. **Engine.** Maintain the engine oil according to the engine manual.
2. **Bearings.** The following bearings are oil impregnated and do not require lubrication, however, their normal life can be extended by lubricating them once a season with a light, non-detergent oil.
 - A. King Pin Bearings (total 4 bearings)
 - B. Rear Axle Bearings (total 3 bearings)
 - C. Front Wheel Bearings (total 4 bearings)
 - D. Deck Wheel Bearings (total 4 bearings)
3. **Throttle Control and Cable.** Wipe oiled rag along entire length of cable.
4. **Chain.** Wipe oiled rag along entire length of chain.

NOTE

Under extremely dusty conditions do not oil the chain.

5. **Linkage.** Oil all deck linkage and height adjustment linkage.
6. **Transmission.** Lubricated at the factory, does not require checking. Lubricate with 4 oz. of Lubriplate No. 310 if disassembled.
7. **Differential.** Lubricated at the factory, does not require checking. Lubricate with 2 oz. of Lubriplate No. 310 if disassembled.

OFF-SEASON STORAGE

NOTE

Engines to be stored over 30 days should be completely drained of fuel to prevent gum deposits forming on essential carburetor parts, fuel filters, fuel lines and tank.

1. Remove all fuel from fuel tank. Run the engine until it stops from lack of fuel. The small amount of fuel that remains in the sump of the tank should then be removed by absorbing it with a clean, dry cloth.
2. While engine is still warm, drain oil from crankcase. Refill with fresh oil.
3. Remove spark plug, pour 1 ounce of SAE 30 oil into cylinder and crank slowly to distribute oil. To prevent accidental starting, DO NOT replace the spark plug.
4. Clean dirt and chaff from cylinder, cylinder head fins and blower housing.
5. Clean all grass from underside of deck.
6. Clean the air filter.
7. Place blocks under frame of mower so that the wheels are off the ground.
8. Cover all bare metal parts, such as the mowing edge of the blades, with grease to prevent rusting.
9. Cover the mower with a tarpaulin or other protective covering.

NOTE: If for any reason Disc Brake is disassembled, be sure round end of push pins (Ref. No. 130) is toward the cam lever (Ref. No. 131).

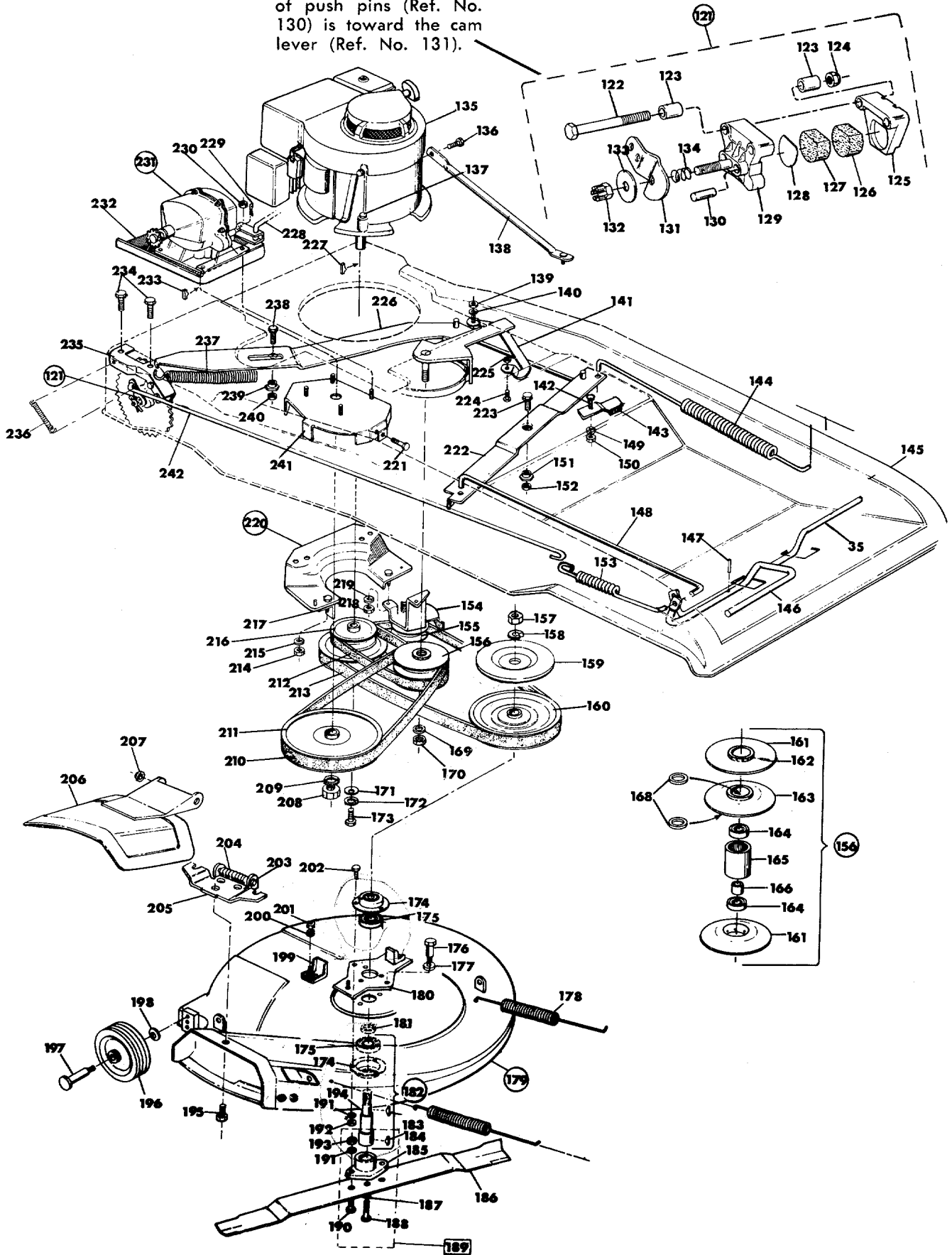

FIGURE 13. EXPLODED VIEW

PARTS LIST FOR MOWER MODEL 132-415

When ordering parts, always give the following information as shown in this list:

1. The PART NUMBER
2. The PART NAME

3. The MODEL NUMBER

Do not use Key Numbers when ordering Parts. Always use Part Numbers.

REF. NO.	PART NO	DESCRIPTION.	REF. NO.	PART NO	DESCRIPTION
10	757-232	Seat Cover (Optional)	98	715-107	Spirol Pin 5/16" Dia. x 1.38" Lg.
11	312-8535	Seat Assembly	99	437-9758	Rear Cover—R.H.
12	723-208	Steering Wheel	100	437-9715	Adj. Brk. Assembly
13	723-207	Steering Wheel Cap	101	722-115	Ball Knob (Transmission)
14	715-131	Spring Pin Roll 1/4" Dia. x 2.00" Lg.	102	720-141	Grip
15	710-224	Hex Hd. Self-Tapping Scr. #10 x .50" Lg.*	103	10083	Rear Cover Center
16	746-172	Throttle Control Assembly	108	710-198	Hex Hd. Sems Cap Scr. 5/16-18 x .75" Lg.*
17	710-224	Hex Hd. Self-Tap Scr. #10 x .50" Lg.*	109	748-151	Flange Bearing
18	11373	Steering Box Top Cover	110	10470	Bearing Plate
19	10357	Handle Stop Assembly	111	710-198	Sems Hex Hd. Cap Scr. 5/16-18 x .75" Lg.*
20	11249	Handle Stop—Knob	112	736-119	Spring Lockwasher 5/16" Scr.*
21	735-126	Rubber Washer .33 I.D. x .87 O.D.	113	712-267	Hex Nut 5/16-18 Thd.*
22	712-429	Hex Inserted Locknut 5/16-18 Thd.	114	10174	Seat Bracket
23	736-159	Flat Washer .344 I.D. x .88 O.D.	115	437-9760	Rear Cover—L.H.
24	10818	Steering Box Front Cover	116	750-140	Steering Wheel Tubing
25	738-143	Shoulder Bolt .498" Dia. x .340" Lg.	117	720-142	Flat Bar Grip
26	11377	Lockout Lever	118	310-9921	Bearing Cap
27	736-232	Wave Washer .530 I.D. x .78 O.D.	119	310-9920	Steering Tube Spacer
28	736-169	Spring Lockwasher 3/8" Scr.*	120	10471	Rear Axle Support Bracket Assembly
29	712-798	Hex Nut 3/8-16 Thd.*	121	761-130	Disc Brake Assembly—Complete
30	10064	Lockout Link Assembly	122	710-378	Hex Hd. Cap Scr.
31	712-107	Hex Center Locknut 1/4-20 Thd.	123	11-1764-0000	Bushing
32	712-267	Hex Nut 5/16-18 Thd.*	124	712-158	Hex Locknut
33	736-119	Spring Lockwasher 5/16" Scr.*	125	12-1329-0000	Casting—Carrier Side
34	10614	Pedal Pad—Vinyl	126	15-1154-1049	Friction Pad .250 Thick
35	11379	Clutch Foot Pedal Rod Ass'y.	127	15-1154-1079	Friction Pad .450 Thick
36	11375	Steering Box	128	03-1345-0000	Disc—Back up
37	715-108	Spirol Pin 1/4" Dia. x 1.00" Lg.	129	12-1984-0007	Casting—Cam Side
42	748-227	Hex Flange Bearing .63055 I.D.	130	05-1033-0000	Push Pin
43	348-9709	Front Axle Ass'y.—L.H.	131	18-1687-0000	Cam Lever
44	711-198	Tie Rod End	132	02-1011-0000	Hex Lock Nut
45	348-9711	Pivot Bar Assembly	133	03-1030-0000	Washer
46	11376	Front Pivot Bracket	134	06-1029-0000	Spring
47	710-198	Hex Sems Cap Scr. 5/16-18 x .75" Lg.*	135		Engine
48	712-923	Hex Inserted Jam Nut 3/8-18 Thd.	136	710-198	Sems Hex Hd. Cap Scr. 5/16-18 x .75" Lg.
49	736-158	Spring Lockwasher 3/8" Scr.*	137	710-442	Hex Hd. Cap Scr. 5/16-18 x 1.50" Lg.*
50	310-9922	Steering Shaft Assembly	138	10400	Engine Brace Ass'y
51	748-227	Hex Flange Bearing .630" I.D.	139	712-267	Hex Nut 5/16-18 Thd.*
52	711-335	Tie Rod	140	736-119	Spring Lockwasher 5/16" Scr.*
53	710-312	Hex Hd. Cap Scr. 3/8-18 x 1.31" Lg.*	141	10419	Variable Speed Bracket Guide Ass'y
54	348-9706	Front Axle Assembly—R.H.	142	710-134	Carriage Bolt 1/4-20 x .62" Lg.
55	735-117	Floor Mat	143	761-147	Blade Brake Ass'y
62	714-507	Cotter Pin 3/32" Dia. x .75" Lg.*	144	732-191	Spring .75 O.D. x 11.00" Lg.
63	734-412	Front Wheel Assembly Complete	145	10057	Frame
64	711-169	Collar 3/8" I.D.	146	10848	Foot Pedal Latch Assembly
65	710-494	Sq. Hd. Set Scr. 5/16-18 x 1/4" Lg.	147	715-103	Spirol Pin 1/8" Dia. x .75" Lg.*
66	712-267	Hex Nut 5/16-18 Thd.*	148	10078	Foot Pedal Rod 18.80" Lg.
67	736-119	Spring Lockwasher 5/16" Scr.*	149	736-329	Spring Lockwasher 1/4" Scr.*
68	348-9721	Pivot Link Assembly	150	712-287	Hex Nut 1/4-20 Thd.*
69	738-140	Shoulder Bolt .437" Dia. x .18" Lg.	151	711-404	Shoulder Nut 5/16-18 Thd.
70	711-332	Lift Bracket Pin .500" Dia. x .78" Lg.	152	712-429	Hex Elastic Stop Nut 5/16-18 Thd.*
71	437-9737	Lockout Link	153	732-245	Brake Spring
72	714-101	Hair Pin Cotter	154	10274	Idler Support Bracket Ass'y
73	348-9761	Deck Link Assembly	155	756-116	V-Belt Idler 3.06 O.D.
74	348-9735	Connecting Rod	156	10438	Variable Speed Pulley Ass'y.—Comp
77	10147	Deck Bracket	157	712-923	Hex Center Lock Jam Nut 3/8-18 Thd.
78	736-192	Flat Washer	158	736-158	Spring Lockwasher 3/8" Scr.
79	748-151	Flange Bearing	159	11073	Brake Disc for Deck Pulley
80	713-357	Chain #41 1/2 x 67 Links Lg.	160	756-143	Deck Pulley
81	713-723	Master Link #41	161	748-177	Sheave Half
85	312-9714	Rear Wheel Hub Assembly	162	715-124	Spirol Pin
86	437-9717	Lift Handle Assembly	163	748-181	Movable Sheave Part
94	501-10108	Rear Wheel Assembly—Complete	164	741-139	Ball Bearing
95	712-798	Hex Nut 3/8-16 Thd.*	165	750-144	Steel Tubing
96	736-169	Spring Lockwasher 3/8" Scr.*	166	750-146	Spacer
97	710-309	Adjusting Screw	168	748-179	Bronze Bushing (Order Ref. No. 163)

PARTS LIST FOR 132-415 CONTINUED

REF. NO.	PART NO.	DESCRIPTION	REF. NO.	PART NO.	DESCRIPTION
169	736-921	Spring Lockwasher 1/2" Scr.*	221	710-117	Hex Hd. Cap Scr. 5/16-24 x 1" Lg. Heat Treated
170	712-384	Hex Center Lock Nut 1/2-13 Thd.*	222	11382	Clutch Rod Bar
171	310-7386	Flat Washer	223	710-322	Sems Hex Hd. Cap Scr. 5/16-18 x 1" Lg.*
172	736-217	Spring Lockwasher 3/8" Scr. Heavy Duty	224	710-272	Hex Hd. Cap Scr. #10-24 x 1/2" Lg.*
173	710-152	Hex Hd. Cap Scr. 3/8-24 x 1" Lg.*	225	712-267	Hex Nut 5/16-18 Thd.*
174	310-8253	Bearing Housing	226	348-9785	Variable Speed Bracket Ass'y
175	741-919	Ball Bearing	227	714-365	#6 Hi-Pro Key 5/32 x 3/8" Dia.
176	738-129	Shoulder Scr. .489" Dia. x 2.005" Lg.	228	10846	Shift Lever Ass'y
177	736-105	Belleville Washer	229	714-507	Cotter Pin
178	732-153	Extension Spring	230	712-429	Hex Elastic Stop Nut 5/16-18 Thd.
179	11085	Deck Assembly	231	717-223	Transmission Assembly—Complete
180	11539	Deck Belt Guard Plate Ass'y	232	10247	Transmission Plate
181	750-142	Spacer .836 I.D. x 1.01 O.D.	233	714-868	Key Woodruff #9*
182	10150	Blade Spindle Ass'y—Complete	234	710-378	Hex Hd. Cap Scr. 5/16-18 x 1/2" Lg.*
183	714-365	#6 Hi-Pro Key 5/32 x 3/8" Dia.	235	10245	Disc Brake Bracket Ass'y
184	714-388	#61 Hi-Pro Key 3/16 x 3/8" Dia.	236	732-157	Spring 38 O.D.
185	748-189	Blade Adapter	237	732-192	Spring Variable Speed Brk.
186	742-127	Blade—25 inch	238	710-322	Sems Hex Hd. Cap Scr. 5/16-18 x 1.00" Lg.*
187	736-217	Spring Lockwasher 3/8" Scr. Heavy Duty	239	711-404	Shoulder Nut 5/16-18 Thd.
188	710-459	Hex Hd. Cap Scr. 3/8-24 x 1 1/2" Lg. Heat Treated	240	712-429	Elastic Stop Nut 5/16-18 Thd.
189	10769	Blade Adapter Kit	241	34819780	Transmission Belt Guard
190	710-117	Hex Hd. Cap Scr. 5/16-24 x 1" Lg. Heat Treated	242	11378	Brake Rod
191	736-119	Spring Lockwasher 5/16" Scr.*	243	10832	Brake Lever Bracket
192	712-267	Hex Nut 5/16-18 Thd.*	244	712-384	Hex Center Locknut 1/2-13 Thd.
193	712-123	Hex Nut 5/16-24 Thd.*	215	348-9760	
194	711-405	Blade Spindle			
195					
196	734-295	Wheel Ass'y for Cutting Deck			
197	738-119	Shoulder Bolt .625" Dia. x 1.750" Lg.			
198	736-105	Belleville Washer			
199	10426	Belt Keeper Assembly			
200	736-119	Spring Lockwasher 5/16-18" Scr.*			
201	712-267	Hex Nut 5/16-18 Thd.*			
202	710-322	Sems Hex Hd. Cap Scr. 5/16-18 x 1.00" Lg.*			
203	711-571	Pivot Pin			
204	732-261	Torsion Spring			
205	11399	Adapter Plate			
206	11571	Chute Deflector			
207	726-106	Push-on Flange Palnut			
208	712-922	Hex Jam Nut 1/2-20 Thd.			
209	736-921	Spring Lockwasher 1/2" Scr.*			
210	754-136	V-Belt 21/32 x 31" Lg.			
211	756-174	Transmission Pulley			
212	754-135	V-Belt 21/32 x 25" Lg.			
213	754-147	V-Belt 21/32 x 52" Lg.			
214	712-267	Hex Nut 5/16-18 Thd.*			
215	736-119	Spring Lockwasher 5/16" Scr.*			
216	756-142	Two-step Engine Pulley			
217	10426	Belt Keeper Assembly			
218	712-267	Hex Nut 5/16-18 Thd.*			
219	736-119	Spring Lockwasher 5/16" Scr.*			
220	10423	Belt Guard Cup Ass'y			

437—Flag Red) When ordering parts if color or finish is important, use the appropriate
 color code shown at left. (e.g. Flag Red finish—10057(437.)
 348—Black)

* For faster service, obtain standard nuts, bolts and washers locally. If these items cannot be obtained locally, order by part number and size as shown on the parts list.

The engine is not under warranty by the mower manufacturer. If repairs or service is needed on the engine, please contact your nearest authorized engine service outlet. Check the "Yellow Pages" of your telephone book under "Engines—Gasoline."

Find It Fast
 In The
 "Yellow Pages"

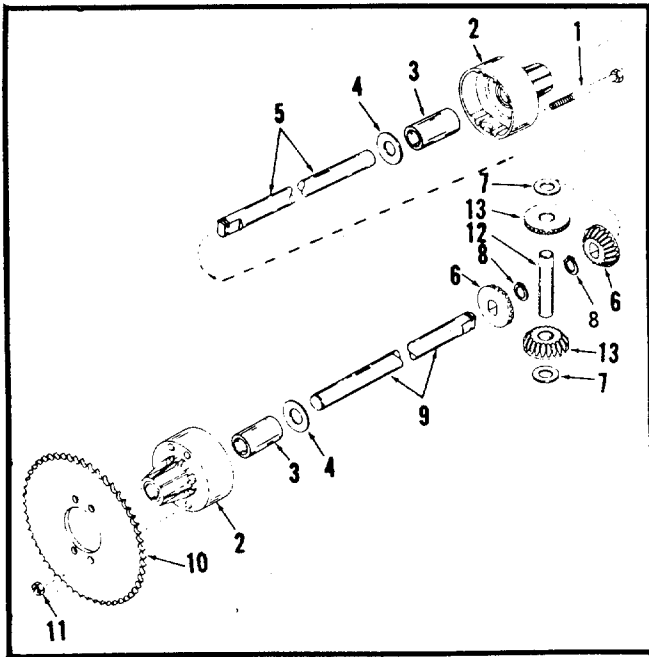

FIGURE 14. MODEL 901-9795 DIFFERENTIAL

PARTS LIST FOR 901-9795 DIFFERENTIAL

REF. NO.	PART NO.	DESCRIPTION
1	710-363	Hex Head Cap Screw 5/16-24 x 4" Lg.*
2	719-150	Differential Housing (2 Req'd)
3	748-169	Sleeve Bearing (2 Req'd)
4	736-188	Washer (2 Req'd)
5	738-128	Shaft—Long
6	748-185	Miter Gear Double "D" Hole
7	736-182	Flat Washer (2 Req'd)
8	716-101	Truarc Snap Ring (2 Req'd)
9	738-127	Shaft—Short
10	394-9054	Sprocket
11	712-237	Hex Center Locknut 5/16-24 Thd.*
12	711-276	Drive Pin
13	748-158	Miter Gear Round Hole
14	715-123	Dowel Pin (Not Shown)

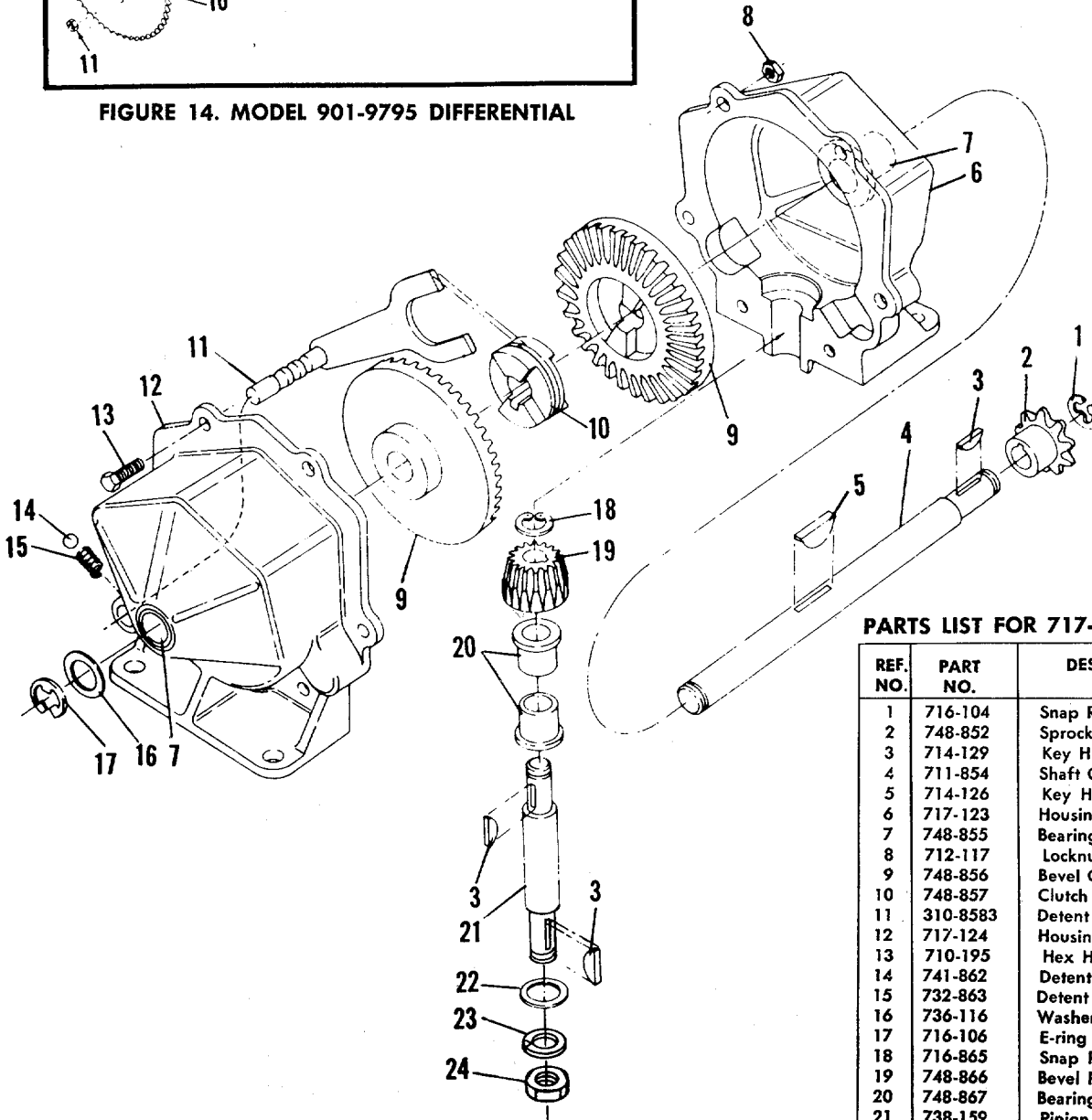

FIGURE 15. MODEL 717-223 TRANSMISSION

PARTS LIST FOR 717-223 TRANSMISSION

REF. NO.	PART NO.	DESCRIPTION
1	716-104	Snap Ring
2	748-852	Sprocket 8T #41
3	714-129	Key Hi-Pro #4
4	711-854	Shaft Output
5	714-126	Key Hi-Pro #606 (Hardened)
6	717-123	Housing Half
7	748-855	Bearing
8	712-117	Locknut 1/4-28 Thd.
9	748-856	Bevel Gear
10	748-857	Clutch Collar
11	310-8583	Detent Shaft Assembly
12	717-124	Housing Half with Detent Hole
13	710-195	Hex Hd. Cap Scr. 1/4-28 x .62
14	741-862	Detent Ball
15	732-863	Detent Spring
16	736-116	Washer
17	716-106	E-ring
18	716-865	Snap Ring #3100-50
19	748-866	Bevel Pinion
20	748-867	Bearing
21	738-159	Pinion Shaft
22	736-192	Washer
23	736-921	Snap Ring 1/2"
24	712-922	Hex Jam Nut 1/2-20 Thd.

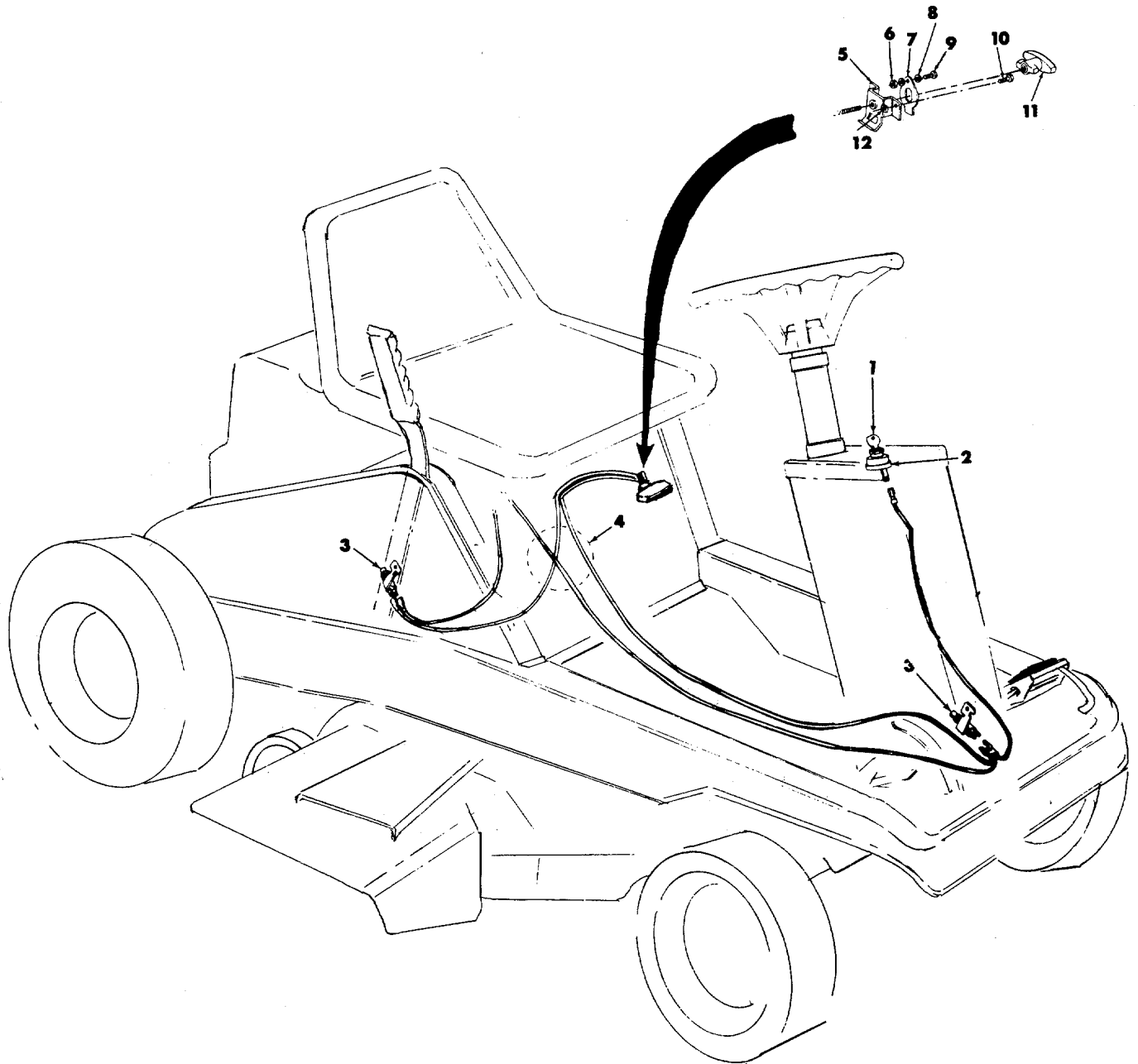

FIGURE 16. ELECTRICAL SYSTEM (RECOIL START MODEL)

PARTS LIST FOR RECOIL START MODEL

Ref. No.	Part No.	Description
1	725-128	Ignition Key
2	725-266	Ignition Switch
3	725-269	Safety Switch
4	725-281	Wire Harness
5	11053	Switch Bracket Ass'y.
6	712-121	Hex Nut #10-24 Thd.*
7	732-257	Switch Spring
8	736-338	Fiber Washer
9	710-425	Truss Hd. Mach. Scr. #10-24 x .62" Lg.*
10	710-351	Truss Hd. Self-Tap Scr. #10 x .50" Lg.
11	11263	Handle—Plastic

WARRANTY

For one year from date of purchase, MTD Products Inc will replace for the original purchaser, free of charge, F.O.B. factory or authorized service firm, any part or parts found to be defective in material or workmanship. All transportation charges on parts submitted for replacement under this warranty must be paid by the purchaser. This warranty does not include replacement of parts which become inoperative through misuse, excessive use, accident, neglect, improper maintenance or alterations by unauthorized persons. This warranty does not include the engine, motor, battery, battery charger or any component parts thereof. For service on these units refer to the applicable manufacturer's warranty.

The above warranty will apply only to the original owner and will be effective only if the warranty card has been properly processed. It will not apply where the unit has been used commercially.

Warranty service is available through your local authorized service dealer or distributor. **UNDER NO CIRCUMSTANCES WILL THE RETURN OF A COMPLETE UNIT BE ACCEPTED BY THE FACTORY UNLESS PRIOR WRITTEN PERMISSION HAS BEEN EXTENDED.**

PARTS INFORMATION

MOWER, TILLER, SNOW THROWER AND TRACTOR PARTS

Mower, tiller, snow thrower and tractor parts are available through the authorized service firms listed below. All orders should specify the model number of your unit, parts numbers, description of parts and the quantity of each part required.

A 1 Engine & Mower Co.
327 East 9th Street
Salt Lake City, Utah 84102

American Electric Ignition Co.
124 N. W. 8th Street
Oklahoma City, Oklahoma 73102

Auto Electric & Carburetor Co.
2625 4th Avenue, S.
P. O. Box 1948
Birmingham, Alabama 35233

Automotive Equipment Service Co.
3117 Holmes Street
Kansas City, Missouri 64109

Bailey's Rebuild Inc.
1325 E. Madison Street
Seattle, Washington 98102

Brown Equipment Distributor Inc.
110 Beech Street
Corydon, Indiana 47112

Bullard Supply
2409 Commerce Street
Houston, Texas 77003

Center Supply Company
6867 New Hampshire Avenue
Takoma Park, Maryland 20012

R. T. Clapp Co.
2016 Magnolia Ave., N. E.
Knoxville, Tennessee 37917

W. B. Clements
400 Salem Avenue
Roanoke, Virginia 24016

Morton B. Collins Co.
300 Birnie Avenue
Springfield, Massachusetts 01107

Dixie Sales Company
P. O. Box 1408
327 Battleground Avenue
Greensboro, North Carolina 27402

East Point Cycle & Key Shop
1617 Whiteway
East Point, Georgia 30044

Gamble Distributors
West End Avenue
Carthage, New York 13619

Garden Equipment Co., Inc.
6600 Cherry Avenue
Long Beach, California 90805

Henzler, Inc.
2015 Lemay Ferry Road
St. Louis, Missouri 63125

Frank E. Ives & Son
1101 Lincoln Avenue
Prospect Park, Pennsylvania 19076

J. W. Jewett Co.
981 Folsom Street
San Francisco, California 94107

Kenton Supply
8216 North Denver Avenue
Portland, Oregon 97217

Kimber's Inc.
615 W. Genesee Street
Syracuse, New York 13204

Marr Brothers
423 E. Jefferson
Dallas, Texas 75203

Mathews Auto Electric Co.
420 East 2nd Street
Tulsa, Oklahoma 74120

McClure Lawn & Garden Supply
1114 Lexington Avenue
Mansfield, Ohio 44907

Memphis Cycle & Supply Co.
421 Monroe Avenue
Memphis, Tennessee 38103

ENGINE PARTS AND SERVICE

Engine parts and service should be handled by your nearest authorized engine service firm. Check the yellow pages of your telephone directory under the listing *Engines - Gasoline*, Briggs and Stratton or Tecumseh Lauson - Power Products.

Moz-All of Florida, Inc.
365 Greco Avenue
Coral Gables, Florida 33146

**National Central, Div. of
Joe Sterling, Inc.**
Drawer "D" 687 Seville Rd.
Wadsworth, Ohio 44281

Power Equipment Distributor
36463 So. Gratiot Avenue
Mt. Clemens, Michigan 48043

Parts & Sales Inc.
335 West St. Charles Road
Villa Park, Illinois 60181

Power Lawn & Garden Equip. Co.
2551-2571 J. F. Kennedy Road
Dubuque, Iowa 52001

Raub Supply Company
James & Mulberry Sts.
Lancaster, Pennsylvania 17604

Radco Distributors
2403 Market Street
P. O. Box 3216
Jacksonville, Florida 32206

Richmond Battery & Ignition
P. O. Box 25369 - 957 Myers St.
Richmond, Virginia 23260

Smith Hardware Company
515 N. George Street
Goldsboro, North Carolina 27530

South Denver Lawn Equip. Co.
527 West Evans
Denver, Colorado 80223

Suhren Engine
8330 Earhart Blvd.
New Orleans, Louisiana 70118

Sutton's Lawn Mower Shop
Route 4, Box 343
North Little Rock, Arkansas 72117

Warner Equipment
7520 Lyndale Avenue, So.
Minneapolis, Minnesota 55423