

OWNER'S GUIDE

Model No. 130-415

10 CENTS

RIDING MOWER

WARRANTY

For one year from date of purchase, MTD Products, Inc., will replace for the original purchaser, free of charge, F.O.B. factory or authorized service firm, any part or parts found to be defective in material or workmanship. All transportation charges on parts submitted for replacement under this warranty must be paid by the purchaser. This warranty does not include replacement of parts which become inoperative through misuse, excessive use, accident, neglect, improper maintenance or alterations by unauthorized persons. This warranty does not include the engine, motor, battery, battery charger or any component parts thereof. For service on these units refer to the applicable manufacturer's warranty.

The above warranty will apply only to the original owner and will be effective only if the warranty card has been properly processed. It will not apply where the unit has been used commercially.

Warranty service is available through your local authorized service dealer or distributor. UNDER NO CIRCUMSTANCES WILL THE RETURN OF A COMPLETE UNIT BE ACCEPTED BY THE FACTORY UNLESS PRIOR WRITTEN PERMISSION HAS BEEN EXTENDED.

WARNING: Should excessive vibration develop, check your blade and blade shaft immediately. Do not operate mower with an unbalanced blade, a damaged blade shaft.

SAFETY RULES

Your rotary mower is a precision piece of power equipment, not a plaything. Therefore exercise extreme caution at all times.

1. Remove all sticks, stones, wire and other hazardous items from lawn before mowing. Such items are dangerous to both the mower and individuals in the vicinity of the mower.
2. Always disconnect spark plug cable during repair or refueling operations.
3. Always start engine from side opposite discharge chute.
4. **NEVER** place hands or feet under mower or near discharge chute while engine is running.
5. Always stop engine when not cutting grass.
6. Do not fill gas tank while engine is running. Do not spill gasoline on hot engine.
7. Keep children and pets away from area at all times during mowing operation. Never allow mower to discharge grass toward any person.
8. Do not attempt to start engine while mower is resting in high grass.
9. **Check all nuts and bolts, particularly the blade bolts, for tightness. This is especially important during the initial operation period. Make this same check periodically thereafter.**
10. While operating the mower, if any foreign object is struck stop the mower and inspect for damage. Do not restart or operate the mower until all damage has been repaired.

ASSEMBLY INSTRUCTIONS

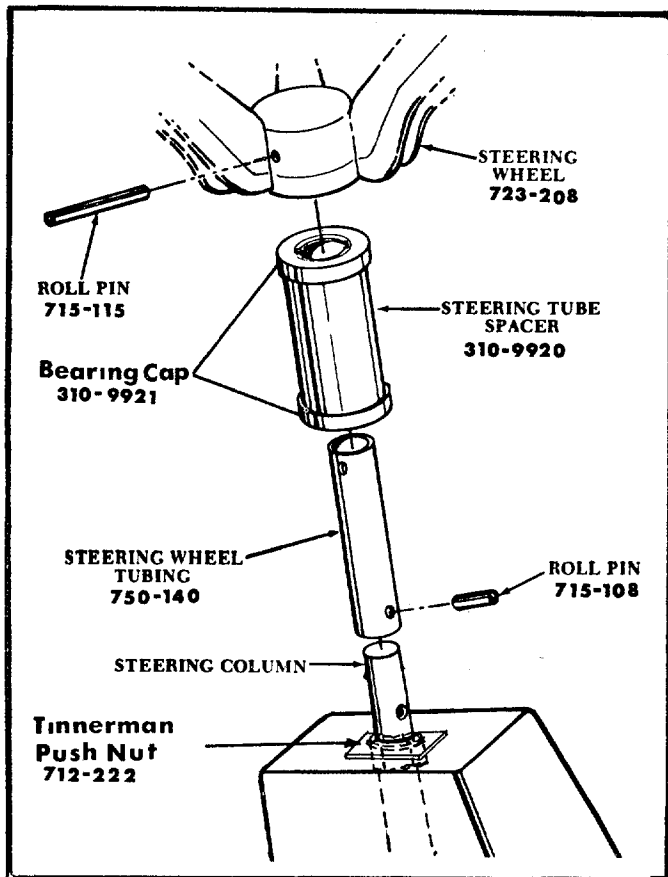

FIG. 1

STEERING WHEEL ASSEMBLY

1. Be sure holes line up in the steering column and steering wheel tubing. (It may be necessary to use a drift to align the holes)
2. Attach steering wheel tubing to steering column with roll pin.
3. Slide steering tube spacer over steering wheel tubing – be sure that the steering tube spacer lays flush against steering box.
4. Align holes in steering wheel and steering wheel tubing.
5. Drive roll pin through the aligned holes.

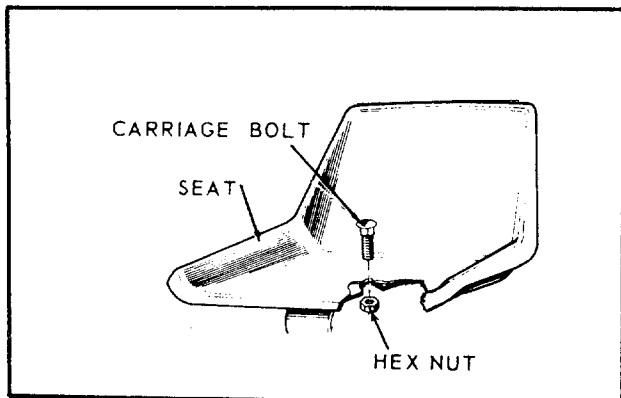

FIG. 2

KNOW YOUR MOWER

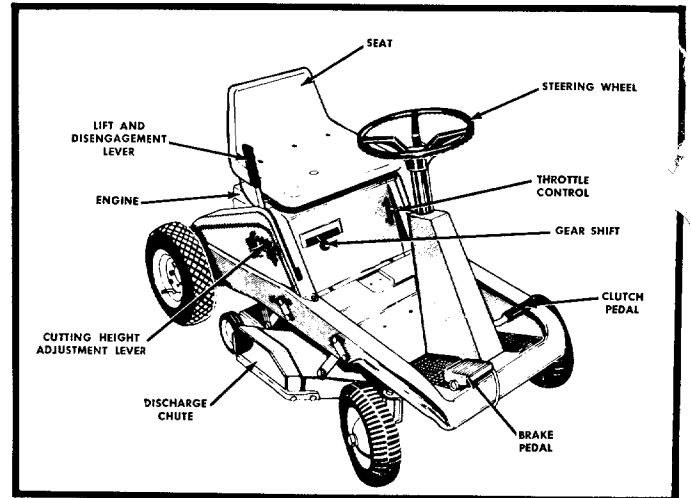

FIG. 3

This Owner's Manual should be read in its entirety before you operate your Rider Mower. The more you know and understand about the machine and its operation, the better job it will do for you. While reading the manual, compare the illustrations with your mower to familiarize yourself with the locations of various controls, lubrication points, attachments, and adjustment features.

Study the operating instructions and safety precautions thoroughly to insure proper functioning of your mower and to prevent injury to yourself and others. Be sure to save this manual for future reference.

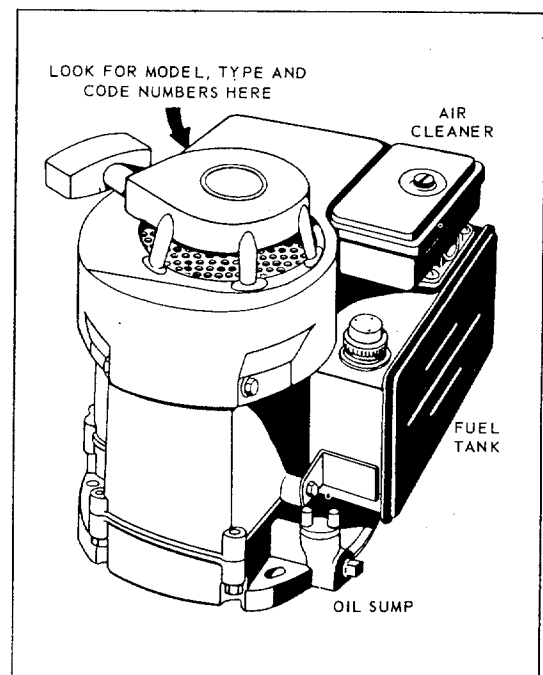

FIG. 4

KNOW YOUR CONTROLS BEFORE OPERATING

Depress the right foot pedal to stop or slow down. Pull the speed control lever into the "Park" position whenever you dismount the rider. The engine DOES NOT have to be running to move the speed control lever into "Park".

Always start the engine with the speed control lever in "Park".

Depress the left pedal, after removing the speed control lever from "Park", to increase your ground speed. This pedal can only be depressed when the engine is operating.

Depress either pedal to obtain the desired ground speed. (See Fig. 5).

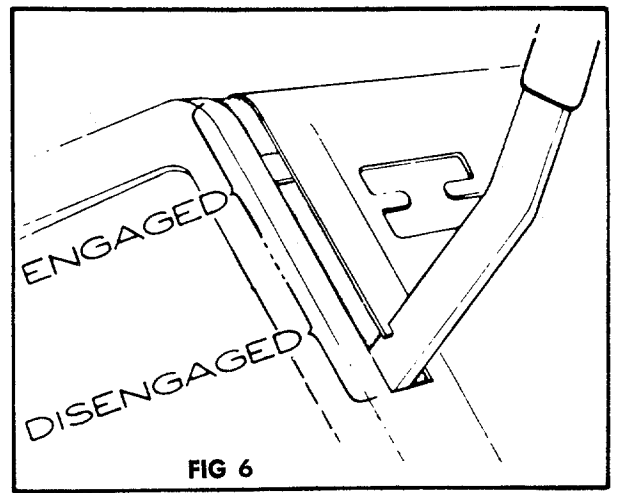
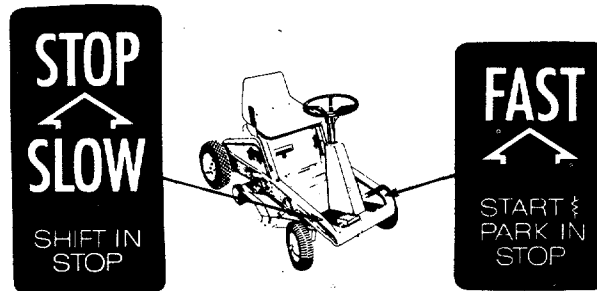

FIG 6

LIFT AND DISENGAGEMENT LEVER

The lift and disengagement lever is used to raise and lower the mowing deck (See Fig. 6). When the lever is in the DISENGAGE position the blades WILL NOT revolve. When it is necessary to drive the mower over a small obstruction such as a clump of dirt or a root, place the lift and disengagement lever in DISENGAGE position. This will raise the deck and the blades will stop revolving automatically.



KNOW HOW TO STOP YOUR MOWER

STOPPING ENGINE — Move the throttle to STOP position (see Fig. 7).

STOPPING THE RIDER

Depress the right foot pedal or pull the speed control lever towards you. (See Fig. 5).

STOPPING BLADES FROM REVOLVING — With your right hand push the lift lever down to DISENGAGE position (see Fig. 6). It can be held in this position by pushing it all the way to the front and moving it to the left.

THROTTLE CONTROL

Your engine has a "choke-a-matic" choke. Move the throttle control lever all the way down (See Fig. 7) to place it in the choke position. One lever operates the choke, regulates the engine speed, and stops the engine.

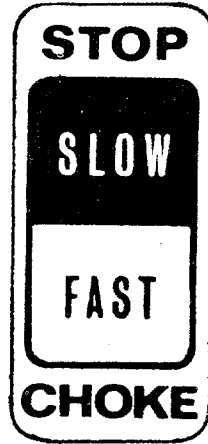

FIG 7

GEAR SHIFT LEVER

The transmission has one forward speed and one reverse speed (See Fig. 8). Variation of travel speed is obtained by use of foot pedals.

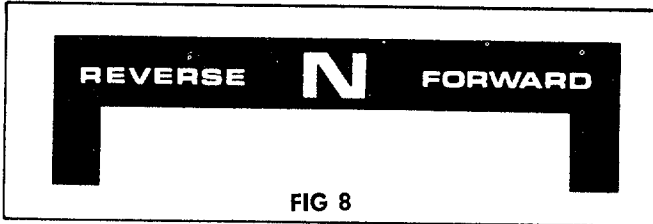

FIG 8

DIFFERENTIAL

The rear axle differential allows one rear wheel to turn faster than another during turns. Differential action eliminates scuffing of the turf by the rear wheels and permits sharper and easier turning.

TIRE PRESSURE – Over-inflation may cause slippage of rear wheels. Under-inflation may cause excessive wear, inner tube damage, or an uneven cut.

Rear 7 to 10 psi

NOTE

The ground speed of the mower is determined by the position of the right and left foot pedals. Your throttle control lever should always be set from $\frac{3}{4}$ to full throttle when you are mowing grass. Engine speed controls the blade speed.

NOTE

Disconnect spark plug wire when the mower is stopped. When stopping the mower for any length of time REMOVE THE SPARK PLUG.

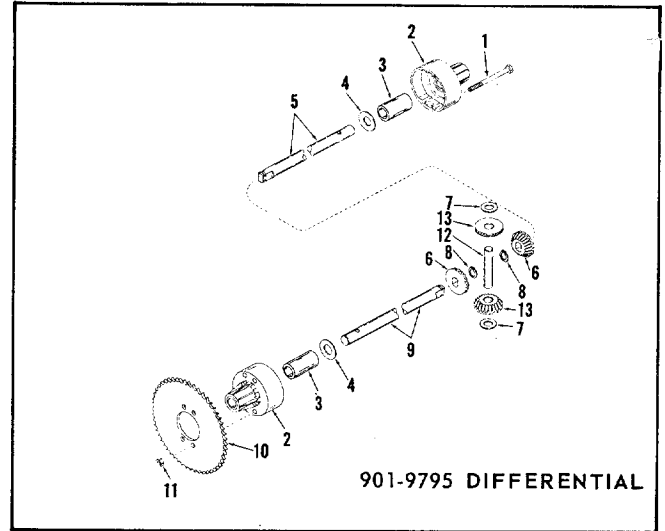

FIGURE 9 — DIFFERENTIAL—EXPLODED VIEW

PARTS LIST

Ref. No.	Part No.	DESCRIPTION
1	710-363	Hex Head Cap Screw – 5/16–18 x 4" lg.*
2	719-150	Differential Housing (2 req'd)
3	748-169	Sleeve Bearing (2 req'd)
4	736-188	Washer (2 req'd)
5	738-128	Shaft – Long
6	748-185	Miter Gear Double "D" Hole
7	736-182	Flat Washer (2 req'd)
8	716-101	Truarc Snap Ring (2 req'd)
9	738-127	Shaft – Short
10	394-9054	Sprocket
11	712-158	Hex Centerlock Nut 5/16–18 thd.*
12	711-276	Drive Pin
13	748-158	Miter Gear Round Hole
14	715-123	Dowel Pin (not shown)

* For faster service obtain standard nuts, bolts, and washers locally. If these items cannot be obtained locally, order by part number and size as shown on parts list.

SEAT – The seat is adjustable to four positions by removing the single hex nut under the seat spring, repositioning the seat, and tightening the nut. See Fig. 2.

PUTTING RIDER MOWER IN MOTION

1. Advance the throttle control lever from $\frac{3}{4}$ to full throttle to prevent strain on the engine and to maintain the necessary speed of the engine to operate the cutting blades.
2. With the right foot pedal still depressed forward, move the gear shift lever to the FORWARD POSITION.

STARTING INSTRUCTIONS

1. Be sure the crankcase is filled with oil as recommended in engine manual and put regular gasoline in the fuel tank.
2. Attach wire to spark plug and put lift lever in DIS-ENGAGE position.
3. Put gear shift lever in neutral.
4. Depress right foot pedal with your toe until it locks.
5. Move throttle control lever to START position.
6. Pull the starter rope with a quick steady motion with your right hand.
7. Slowly return the throttle control lever to the running position after the engine has started.

CHECKS TO PERFORM IF MOWER WILL NOT START

1. Be sure that there is gasoline in the gasoline tank.
2. Be sure the spark plug wire is connected.
3. Be sure the choke valve is shutting properly. See Adjustment Section.
4. Be sure air filter is clean. See Maintenance Section
5. Clean out chaff and dirt which affects the cooling of the engine. See Maintenance Section.
6. Be sure spark plug is clean. To insure starting, the spark plug should be changed once a year.
7. Your carburetor may require adjustment. Adjust it as outlined in Adjustment Section.
8. Check for flooding. Remove spark plug. If wet, plug should be dried.
9. Check magneto. Hold spark plug wire 3/16 inch from engine. Spark should jump from the terminal to the engine when cranked. If no spark occurs, have the magneto tested.

NOTE

A brief break-in period is necessary to insure maximum engine life. This consists of running the engine at half speed for a period of time required to use one tank full of gasoline. This is necessary on the initial run only. It is also recommended that the crankcase oil be changed after the first five (5) hours of operation. This allows for the removal from the crankcase of any impurities which may have accumulated during the break-in period.

ADJUSTMENTS

THROTTLE CONTROL —

To Check Operation:

1. Remove air cleaner.
2. Move throttle control lever to CHOKE position. The carburetor choke should be closed.
3. Move throttle control lever to STOP position. Lever should make good contact with stop switch.

To Adjust:

Place throttle control lever in FAST (high speed) position. Loosen control casing clamp screw "B". Move control casing "A" and wire until lever "D" touches choke operating link at "C". Tighten casing clamp screw "B". Replace air cleaner.

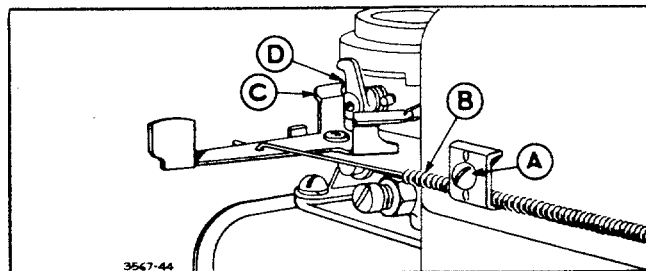

FIG. 10

CARBURETOR ADJUSTMENTS

Carburetors are adjusted at the factory and normally do not need adjustment unless they have been disassembled.

Initial Adjustment After Re-assembly

Turn needle valve clockwise until it just closes. CAUTION: Valve may be damaged by turning it in too far. Now open needle valve 1-1/8 turns counterclockwise. Close idle valve in same manner and open 1-1/8 turns. This initial adjustment will permit the engine to be started and warmed up prior to final adjustment.

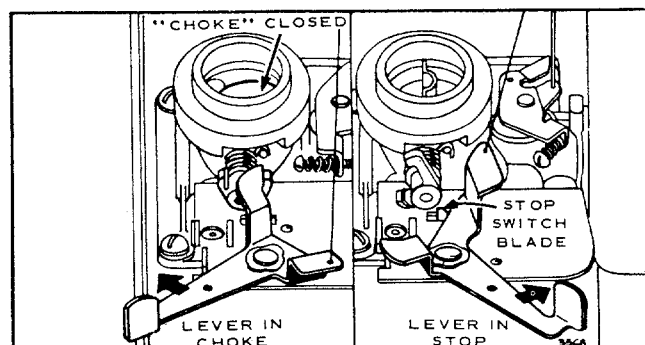

FIG. 11

Final Adjustment (See Fig. 11)

Turn needle valve in until engine misses (lean mixture). Then turn it out past smooth operating point until engine runs unevenly (rich mixture). Now turn needle valve to the mid-point between rich and lean so the engine runs smoothly.

Hold throttle at idle position and set idle speed adjusting screw until fast idle is obtained (1750 RPM). Hold throttle in idle position and turn idle valve in (lean) and out (rich) until engine idles smoothly. Then reset idle speed adjusting screw so that engine idles at 1750 RPM. Release throttle - engine should accelerate without hesitation or sputtering. If engine does not accelerate properly, the carburetor should be re-adjusted to a slightly richer mixture.

CUTTING HEIGHT - Your rider mower is designed to mow grass at various heights. To disengage the power to the blades move the lift and disengagement lever to the DISENGAGE position. The blades will not rotate when the lift lever is in this position. However, ALWAYS shut the engine off and disconnect the spark plug wire when cleaning grass from the discharge chute.

There are two ways to set the mowing height on your rider mower. One setting is for rough mowing and the other is for normal mowing.

NORMAL MOWING - Set your mowing height with the individual wheel adjusters located on the deck. Move the height adjustment handle all the way to LOW CUT position. Place the lift and disengagement lever in ENGAGE position. This will allow the deck to "float" and follow the contour of the ground.

CUTTING HEIGHT - Adjustment may be made by removing and moving wheel studs on the cutting deck to desired position. Cutting heights will be raised as wheel studs are moved to a lower hole and lowered as wheel studs are moved to a higher hole in the deck. Both wheel studs must be mounted in a relative position to the deck.

ROUGH TERRAIN MOWING - With the lift and disengagement lever in DISENGAGE position, unscrew the height adjustment handle until it can be moved to the desired mowing height (See Fig.12) and tighten it. Set the individual wheel adjusters so that the wheels clear the ground by 1/4 inch to prevent scalping.

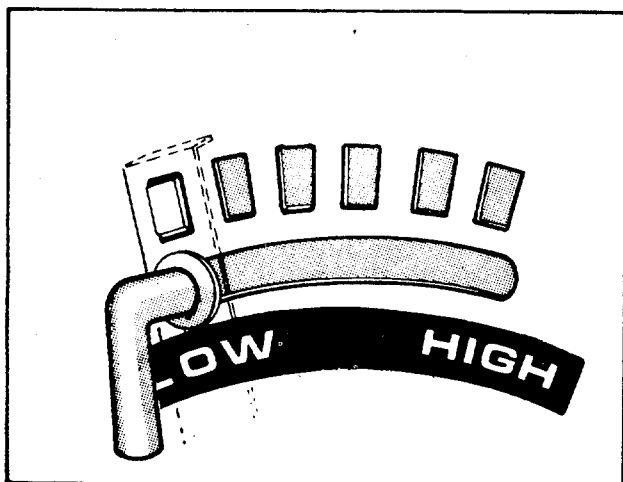

FIG. 12 - LIFT LEVER ADJUSTMENT

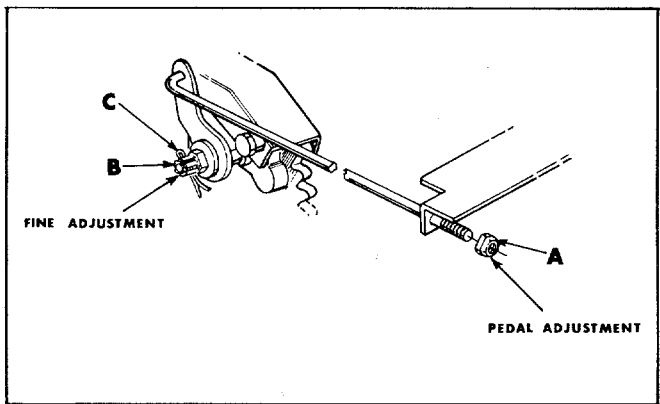

FIG. 13

PEDAL ADJUSTMENT - To take up the adjustment on the brake linkage, tighten or loosen the hex nut (A) on brake linkage. (See Fig. 13).

FINE BRAKE ADJUSTMENT - Remove hair pin (C). Turn the castle nut (B) clockwise to tighten one quarter revolution and check brakes. Repeat as necessary to have proper braking power. Replace hair pin (C). (See Fig. 13).

CHAIN ADJUSTMENT - After the first five hours of operation the initial slack should be removed from the chain. The chain should be tight enough so that it deflects approximately 1/2" when it is depressed with your thumb.

To remove the slack, turn the adjusting bolt (Ref. 106) clockwise with a 1/2" open end or box wrench until the proper tension is obtained. The adjusting bolt is located under the frame of the mower in front of the transmission pulley. Chain adjustment screw (Ref. 106) is mounted on the transmission belt guard (Ref. 105).

MAINTENANCE

BEARINGS - Lifetime graph oil front wheel bearings and rear axle spherical bearings require little lubrication. However, a light film of oil applied to these bearings will reduce normal friction. Maintain a light film of oil on the chain at all times, except where mower is used under extremely dusty conditions. Lubricate all other moving parts with light oil after every 25 hours of operation. Bearings in the clutch idler and the blade spindles are permanently sealed and require no lubrication.

TRANSMISSION - The transmission is filled at the factory and requires no further lubrication.

BLADES— Sharp and balanced blades are essential for efficient mowing and long mower and engine life. When sharpening blades, file equal amounts of metal from each side. The blades should be balanced before they are reinstalled. An unbalanced blade will cause excessive vibration and undue wear on the mower and the engine. When reassembling, all parts must be installed in the proper order and fastened securely.

REMOVING BLADES

Remove the 3/8" bolt and lockwasher. Pull the blade and adapter off the mower deck. To remove the adapter from the blade, remove the two 5/16" bolts, lockwashers and nuts. See Fig. 14.

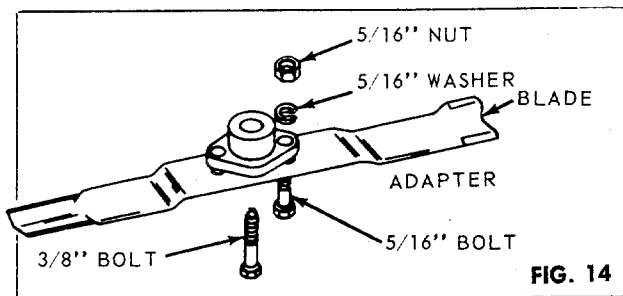

FIG. 14

NOTE

All set screws are held in place with a bolt and nut sealant (such as Loctite). To remove set screws, heat the set screw to approximately 400°F with a butane or similar torch and then remove with an Allen wrench. When replacing the set screws, it is not necessary to remove all the old traces of the sealant; however, they must be free of grease and oil before applying more sealant. Gasoline will clean these parts.

MOWER DECK— The underside of the mower deck should be cleaned after each period of use as grass clippings, leaves, dirt, and other matter will accumulate. This accumulation of grass clippings, etc., is undesirable as it will invite rust and corrosion and may cause an uneven discharge of grass clippings at the next mowing.

The deck may be cleaned by tilting the mower on its left side, so that it rests on a block, as shown in Fig. 16. Scrape clean with a suitable tool or by washing with a stream of water from a garden hose. Be sure to disconnect the spark plug wire and ground it while performing this maintenance.

CAUTION

Do not direct the stream of water at a hot engine as damage to the engine may result.

Remove spark plug wire and ground before attempting any adjustments on the mower.

To remove blade drive belt

1. Put deck in disengaged position.
2. Remove belt keeper (Ref. No. 137) and idler pulley (Ref. No. 121).
3. Remove belt (Ref. No. 132) from engine pulley (Ref. No. 136).
4. Put deck in lowest cutting position.
5. Remove deck belt guard (Ref. No. 149).
6. Install new belt and reverse the above steps.

To remove engine drive belt and transmission drive belt

1. Put deck in disengaged position.
2. Remove idler support bracket (Ref. No. 120).
3. Remove belt guard (Ref. 118).
4. Slip blade belt (Ref. No. 132) off of engine pulley (Ref. No. 136).
5. Lock foot pedal in parking position, and engage deck to lowest cutting position.
6. Slip drive belt (Ref. No. 133) off engine pulley (Ref. No. 136) towards the frame.
7. Remove snap ring (Ref. No. 129) and drop transmission pulley (Ref. No. 131).
8. Remove hex nut (Ref. No. 126) and spring lockwasher (Ref. No. 125), and pull down variable speed pulley (Ref. No. 119).
9. Install new belts and reverse the above steps.

Change oil after first 5 hours of operation. Thereafter, change oil every 25 hours of operation. Remove oil drain plug and drain oil while engine is **warm**. Replace drain plug. Remove oil filler plug and refill with new oil of proper grade. Replace oil filler plug.

CLEAN COOLING SYSTEM

Grass or chaff may clog cooling system after prolonged service in cutting tall dry grasses or hay. Continued operation with a clogged cooling system causes severe overheating and possible engine damage. Remove blower housing and clean regularly. See Fig. 15.

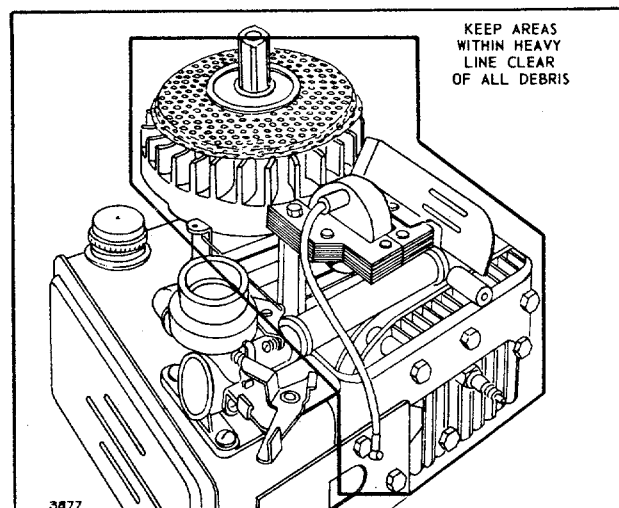

FIG. 15

BELT REPLACEMENT 130-415

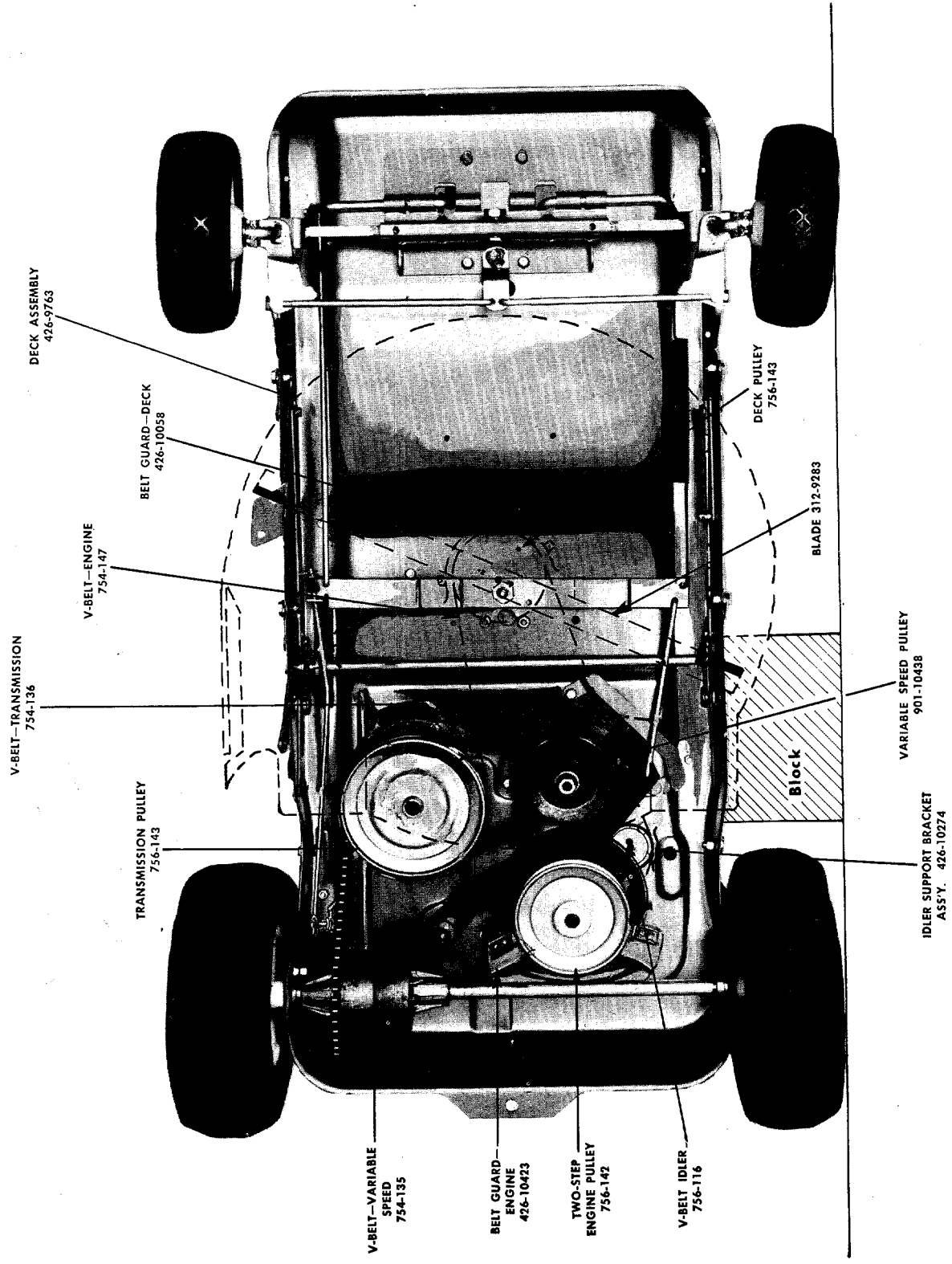

FIG. 16

LUBRICATION

1. ENGINE

Fill Sump Pump With Oil

Remove the oil filler plug or oil minder located on base of engine. Place the engine level. Fill the oil sump to overflowing. POUR SLOWLY. CAPACITY 2-1/4 pints. Replace the filler plug.

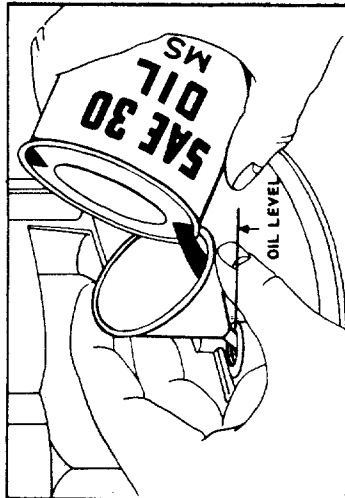

OIL RECOMMENDATIONS

SUMMER
(Above 40° F.)
Use SAE 30

WINTER
(Below 40° F.)
Use SAE 5W-20

Lubrication points 2 thru 5 have oil impregnated bronze bearings and do not have to be lubricated, however, a light film of oil applied to these bearings will reduce normal friction. Use engine oil for lubrication points 2 thru 8.

2. Upper and lower bearings in steering (Total 2 bearings)
3. Front wheel bearings (Total 4 bearings)
4. Front axle bearings (Total 4 bearings)
5. Rear axle bearings (Total 2 bearings)
6. All deck linkage.
7. Clutch pedal linkage.
8. Throttle control and cable - wipe oil rag entire length of cable.
9. Wheels on cutting unit to be greased once each season with multi-purpose automotive grease. Use hand or pressure type gun.
10. Chain (not shown) oil entire length of chain and wipe off excessive oil.
11. Transmission - sealed at factory, does not require checking. (Lubricated with 4 oz. No. 310 Lubriplate).
12. Differential (Not Standard Equipment) - sealed at factory, does not require checking. (Lubriplated with 2 oz. of No. 310 Lubriplate).

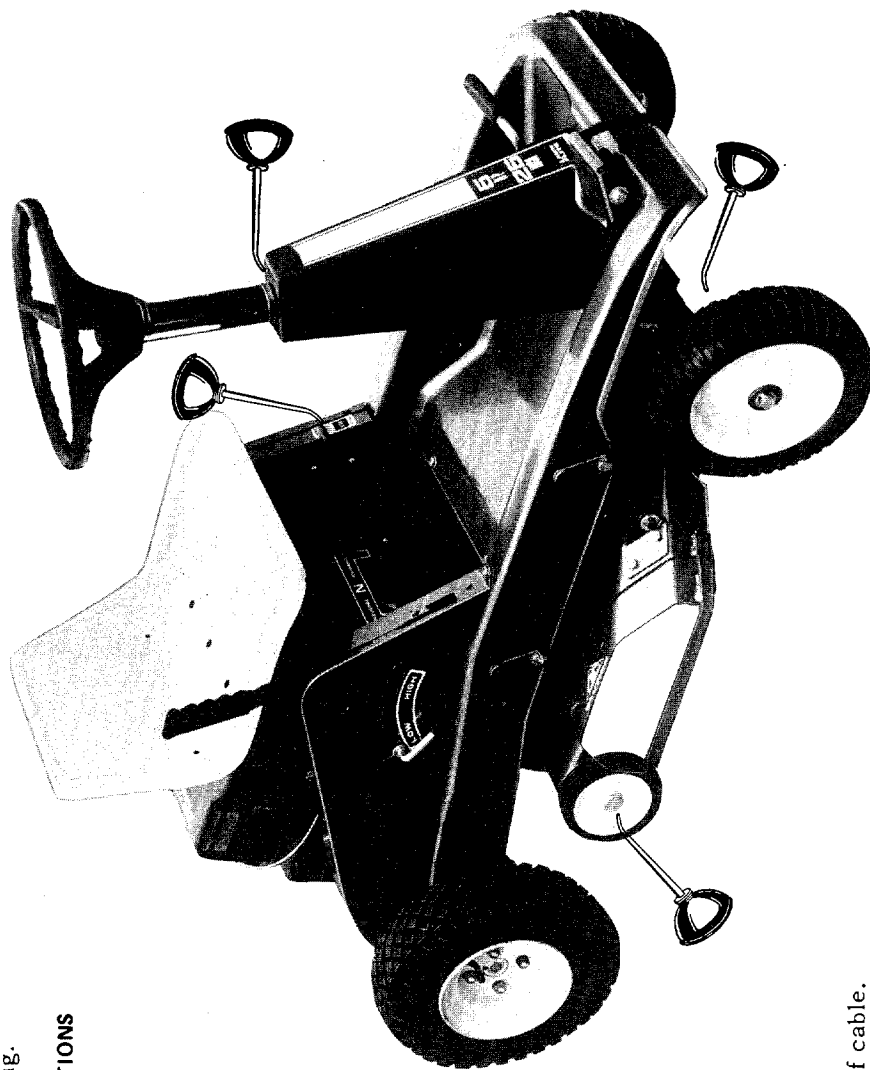

FIG. 17

OFF SEASON STORAGE

NOTE

Engines to be stored over 30 days should be completely drained of fuel to prevent gum deposits forming on essential carburetor parts, fuel filter, fuel lines, and tank.

1. Remove all fuel from fuel tank. Run the engine until it stops from lack of fuel. The small amount of fuel that remains in the sump of the tank should then be removed by absorbing it with a clean, dry cloth.
2. While engine is still warm, drain oil from crankcase. Refill with fresh oil.
3. Remove spark plug, pour 1 ounce of SAE-30 oil into cylinder, and crank slowly to distribute oil. To prevent accidental starting, DO NOT replace the spark plug.
4. Clean dirt and chaff from cylinder, cylinder head fins, and blower housing.
5. Clean all grass from underside of deck.
6. Clean the air filter.
7. Place blocks under frame of mower so that the wheels are off the ground.
8. Cover all bare metal parts, such as the mowing edge of the blades, with grease to prevent rusting.
9. Cover the mower with a tarpaulin, or other protective covering.

SERVICE AIR CLEANER REGULARLY

When assembling make certain the lip of the foam element extends over edge of the air cleaner body. The foam element will form a protective seal.

1. Remove two screws and lift off complete air cleaner assembly.
2. Remove screen and spacers from foam element.
3. Remove foam element from air cleaner body.
4. A. Wash foam element in kerosene or liquid detergent and water to remove dirt.
B. Wrap foam in cloth and squeeze dry.
C. Saturate foam in engine oil. Squeeze to remove.
D. Assemble parts - fasten to carburetor with screw. See Fig. 18.

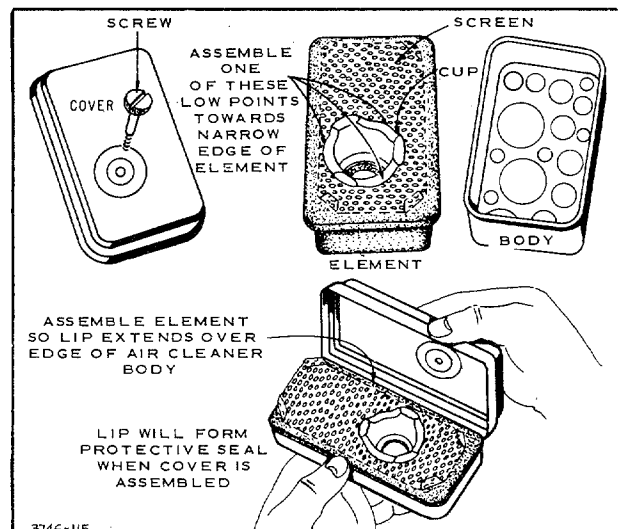

FIG. 18

NOTE: This instruction manual covers various models and all accessories shown do not necessarily apply to your model mower.

If repairs or service is needed on the engine, please contact your nearest authorized engine service outlet. Check the "Yellow Pages" of your telephone book under "Engines - Gasoline"



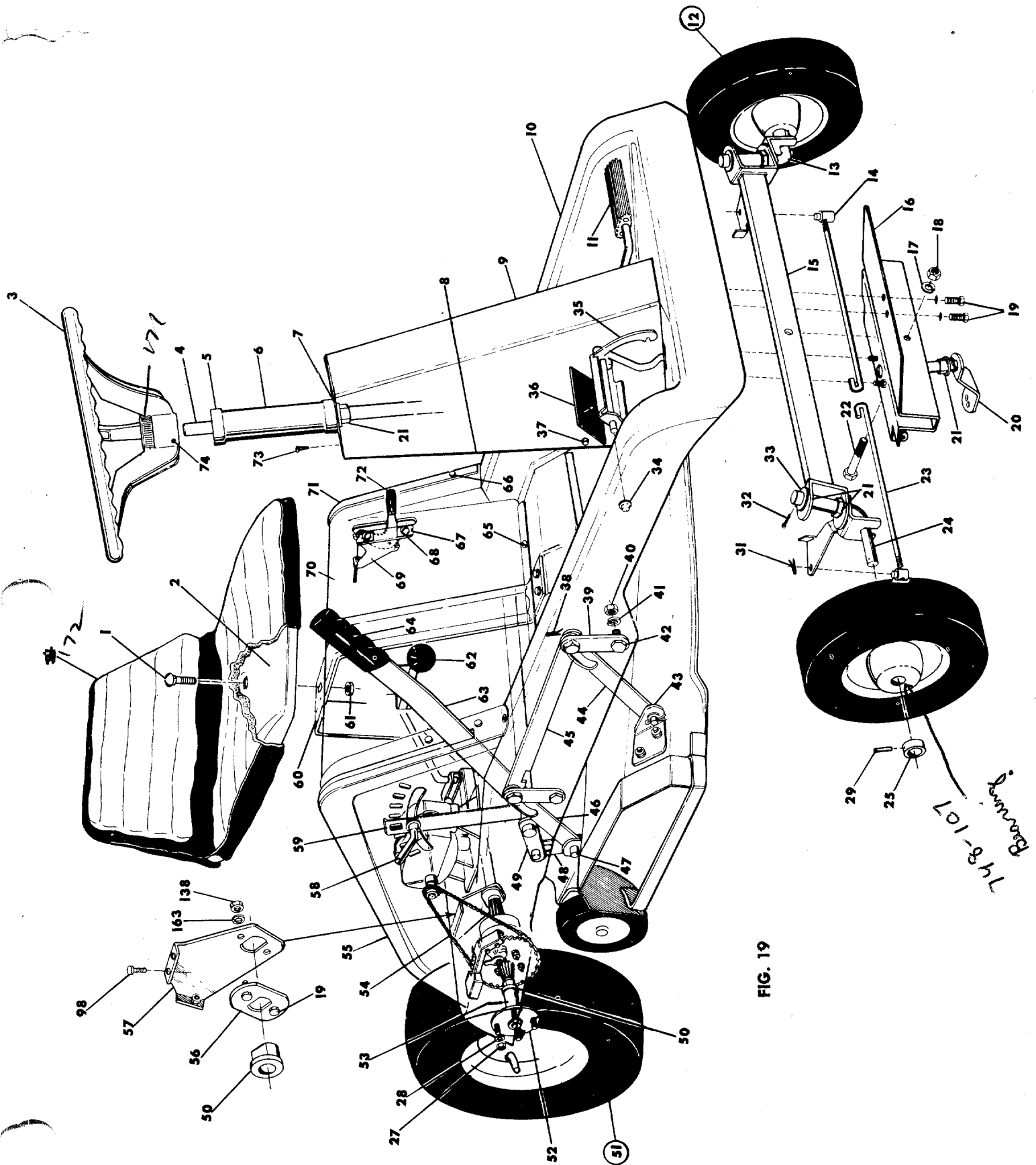

FIG. 19

148-107
Barney

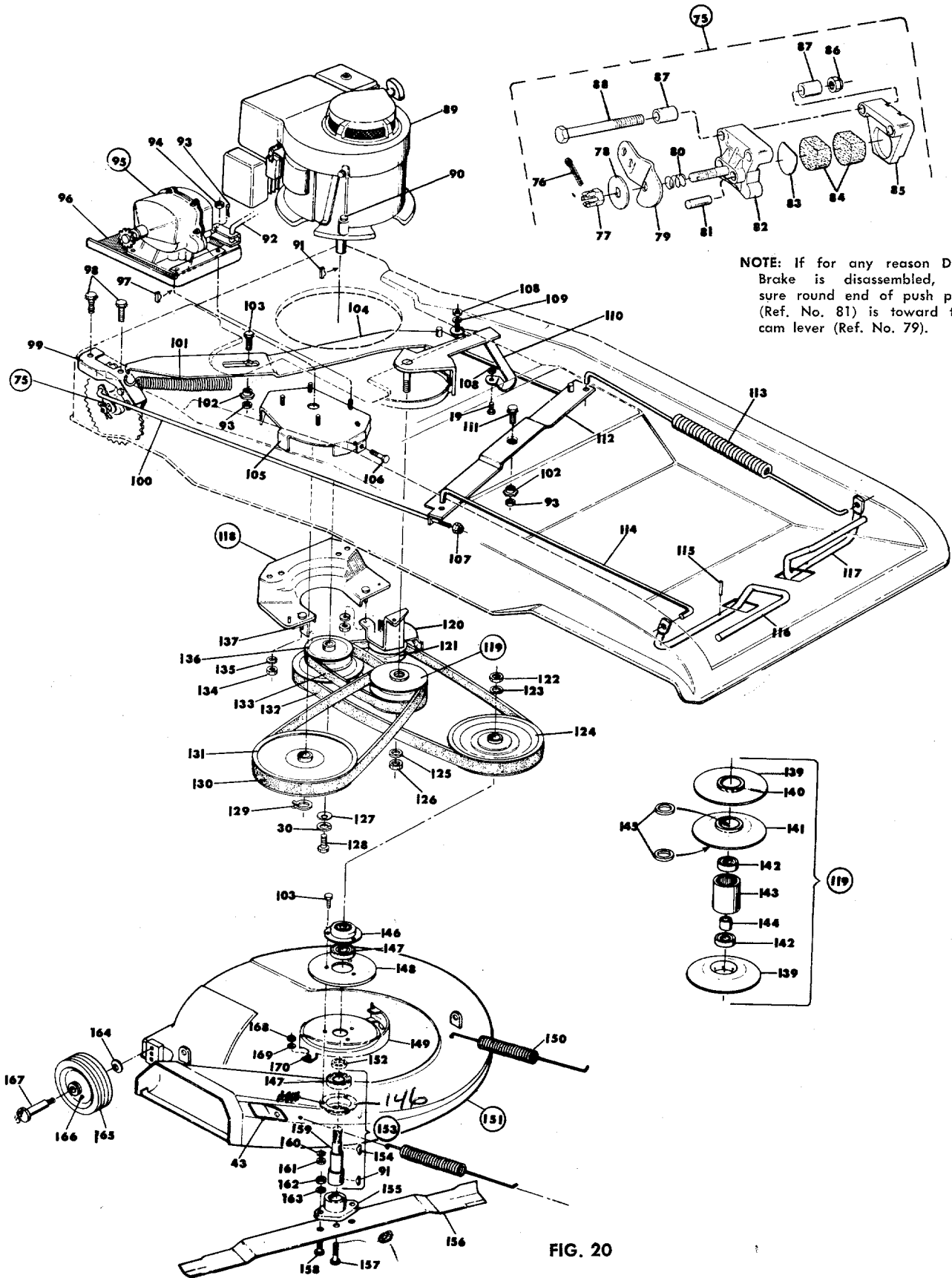

FIG. 20

PARTS LIST FOR MOWER MODEL 130-415

When ordering repair parts, always give the following information as shown in this list.

1. The PART NUMBER
2. The PART NAME
3. MODEL NUMBER

DO NOT use Reference Numbers when ordering Repair Parts, always use Part Numbers.
Your lawn mower is right hand (R.H.) or left hand (L.H.) as you ride.

REF. NO.	PART NO.	DESCRIPTION
1	710-385	Carriage Bolt 1/2-13 x 1" Lg.*
2	312-8535	Seat Assembly
3	723-208	Steering Wheel
4	750-140	Steering Tube
5	310-9921	Bearing Cap
6	310-9920	Steering Tube Spacer
7	712-222	Tinnerman Pushnut
8	394-9919	Steering Box Cover
9	394-9917	Steering Box Assembly
10	426-10057	Frame
11	731-142	Foot Pedal Bar
12	501-10151	Front Wheel Complete
	734-300	Tire 10.25 x 3.25
13	310-9709	Axle Assembly—Front L.H.
14	711-198	Pivot Bushing
15	426-9711	Pivot Bar Ass'y.
16	426-9728	Front Pivot Bracket
17	736-158	Spring Lockwasher 5/8 scw.*
18	712-923	Locknut 5/8 Thd.*
19	710-272	Hex Head Cap Scw. 10-24 x 1/2" Lg.*
20	310-9922	Steering Shaft Assembly
21	748-227	Flange Bearing 5/8 I.D.
22	710-312	Hex Hd. Cap Scw. 1/4-20 x 1/2" Lg.*
23	711-335	Tie Rod
24	310-9706	Axle Assembly—Front R.H.
25	711-169	Collar 5/8 I.D.
29	710-421	Allen Set Scw. 5/16-18 x 1/4 Lg.*
31	714-507	Cotter Pin*
32	714-111	Cotter Pin*
33	736-860	Flat Washer .64 I.D.
34	726-221	Push Cap 1/2 Diameter
35	426-10054	Foot Pedal Lock
36	723-214	Foot Pedal Pad
37	710-240	Sems Hex Hd. Self Tap Scw. Type F. 10-32 x 1/2" Lg.*
38	714-101	Hairpin—Cotter
39	426-9721	Pivot Link Assembly
40	712-267	Hex Nut 5/16-18 Thd.*
41	736-119	Spring Lockwasher 5/16 scw.*
42	711-118	Shoulder Bolt 5/16-18
43	426-10147	Deck Bracket
44	426-9761	Deck Link Assembly
45	426-9735	Connecting Rod
46	426-9762	Deck Link
47	711-332	Lift Bracket Pin
48	426-9737	Lockout Link
49	736-192	Flat Washer .53 I.D.*
50	748-151	Flange Bearing 3/4 I.D.
51	501-10108	Rear Wheel Assembly—Complete
	734-301	Tire—4.10 x 3.50-6
52	312-9714	Hub Assembly—Rear
53	715-107	Spirol Pin
54	713-357	Chain W/Master Link #41 x 34"
55	426-9758	Rear Cover R.H.
56	426-10470	Bearing Plate
57	426-10471	Rear Axle Support Bracket Ass'y.
58	710-309	Adjusting Screw
59	426-9715	Adj. Bracket Assembly
60	426-10174	Seat Bracket Assembly
61	712-384	Hex Center Locknut 1/2-13 Thd.*
62	722-115	Knob—Gear Shift
63	426-9717	Lift Handle Ass'y.
64	720-141	Handle Grip
65	710-255	Truss Hd. Mach. Scw. 1/4-20 x 3/4 Lg.*
66	710-240	Sems Hex Hd. Self Tap Scw. Type F. 10-32 x 1/2" Lg.*
67	712-147	Speed Nut
68	710-272	Hex Hd. Cap Scw. 10-24 x 1/2" Lg.*
69	746-131	Throttle Control—Complete

PARTS LIST FOR MOWER MODEL 130-415

REF. NO.	PART NO.	DESCRIPTION
70	426-10083	Rear Cover—Center
71	426-9760	Rear Cover—L.H.
72	722-111	Knob—Throttle Control
73	710-541	Sheet Metal Scw. #8 x 3/8 Type A*
74	715-115	Spirol Pin
75	723-229	Disc Brake Assembly†
76	5-1012	Cotter Pin†
77	2-1011	Castle Nut†
78	3-1030	Thrust Washer 5/16 I.D.†
79	1004-1	Cam Lever†
80	6-1029	Compression Spring†
81	5-1033	Push Pin†
82	1027	Casting, Cam Side†
83	3-1031	Back Up Disc†
84	1070-J-69	Friction Pads†
85	1536	Casting, Carrier Side†
86	2-1014	Hex Locknut 5/16-24 Thd.†
87	1171-2	Bushing 5/16 I.D. x 1/2" Lg.†
88	1-1187	Hex Hd. Cap Scw. 5/16-24 x 2 3/4 Lg.†
89		Engine
90	710-442	Hex Hd. Cap Scw. 5/16-18 x 1 1/2" Lg.*
91	714-365	Key—Hi Pro #505*
92	310-10276	Shift Lever Assembly
93	714-507	Cotter Pin*
94	712-429	Hex Elastic Stop Nut 5/16-18 Thd.*
95	901-8500	Single Speed Transmission
96	426-10247	Transmission Plate
97	714-868	Key Woodruff #9*
98	710-378	Hex Hd. Cap Scw. 5/16-18 x 1/2" Lg.*
99	426-10245	Disc Brake Bracket Assembly
100	711-427	Brake Rod
101	732-192	Spring—L Variable Drive
102	711-404	Shoulder Nut 5/16-18 Thd.
103	710-322	Sems Hex Hd. Cap Scw. 5/16-18 x 1" Lg.*
104	426-9785	Variable Speed Bracket Ass'y.
105	426-9780	Transmission Belt Guard
106	710-117	Hex Hd. Cap Scw. 5/16-24 x 1" Lg. Heat Treated
107	712-324	Hex Elastic Stop Nut 1/4-20 Thd.*
108	712-267	Hex Nut 5/16-18 Thd.*
109	736-119	Spring Lockwasher 5/16 Scw.*
110	426-10419	Variable Speed Bracket Guide Ass'y.
111	710-322	Sems Hex Hd. Cap Scw. 5/16-18 x 1" Lg.*
112	426-10056	Clutch Rod Bar
113	732-198	Extension Spring 17 1/2" Lg.
114	310-10078	Foot Pedal Rod
115	715-103	Rod Pin
116	310-10052	Foot Pedal R.H.
117	310-10053	Foot Pedal L.H.
118	426-10423	Belt Guard Ass'y.—Engine
119	901-10438	Variable Speed Pulley—Complete**
120	426-10274	Idler Support Bracket Ass'y.
121	756-116	V-Belt Idler
122	712-923	Locknut 3/8 Thd.*
123	736-158	Spring Lockwasher 3/8 Scw.*
124	756-143	Pulley—Deck
125	736-921	Spring Lockwasher 1/2" Scw.*
126	712-384	Hex Center Locknut 1/2-13 Thd.*
127	310-7386	Flat Washer
128	710-152	Hex Hd. Cap Scw. 3/8-24 x 1" Lg.*
129	716-115	Snap Ring
130	754-136	V-Belt 21/32 x 31" Lg.—Transmission
131	756-143	Transmission Pulley
132	754-147	V-Belt 21/32 x 52" Lg.—Engine
133	754-135	V-Belt 21/32 x 25" Lg.—Variable Speed
134	712-267	Hex Nut 5/16-18 Thd.*
135	736-119	Spring—Lockwasher 5/16 Scw.*
136	756-142	Engine Pulley—Two-Step
137	426-10426	Belt Keeper Ass'y.
138	712-267	Hex Nut 5/16-18 Thd.*
139	748-177	Sheave Half**
140	715-124	Spirol Pin**
141	748-181	Movable Sheave Part**
142	741-139	Ball Bearing**
143	750-144	Steel Tubing**

PARTS LIST FOR MOWER MODEL 130-415

144	750-146	Spacer**
145	748-179	Bronze Bushing (Order Ref. No. 141)**
146	310-8253	Bearing Housing‡
147	741-919	Ball Bearing‡
148	426-10069	Deck Reinforcement
149	426-10058	Belt Guard—Deck
150	732-153	Extension Spring
151	426-9763	Deck Assembly
152	750-142	Spacer‡
153	901-10150	Blade Spindle Ass'y.—Complete‡
154	714-388	Key Hi-Pro #506*
155	748-100	Blade Adaptor
156	312-9283	Blade—25"
157	710-113	Hex Hd. Cap Scw. 3/8-24 x 1 1/2" Lg.—Heat Treated
158	710-117	Hex Hd. Cap Scw. 5/16-24 x 1" Lg.—Heat Treated
159	711-405	Blade Spindle‡
160	736-119	Spring Lockwasher 5/16 Scw.*
161	712-267	Hex Nut 5/16-18 Thd.*
162	712-123	Hex Nut 5/16-24 Thd.*
163	736-119	Spring Lockwasher 5/16 Scw.*
164	736-105	Belleville Washer*
165	501-10237	Wheel Assembly—Cutting Deck
166	737-113	Grease Fitting
167	738-119	Axle Bolt
168	712-287	Hex Nut 1/4-20 Thd.*
169	736-329	Spring Lockwasher 1/4 Scw.*
170	710-289	Hex Hd. Cap Scw. 1/4-20 x 1/2" Lg.*

171 - 723-207 cap

172 - 723-232 seat cover

*For faster service obtain standard nuts, bolts, and washers locally. If these items cannot be obtained locally, order by part number and size as shown on parts list.

†Part of Disc Brake Assembly Complete—723-229.

‡Part of Blade Spindle Assembly Complete—901-10150.

**Part of Variable Speed Assembly Complete—901-10438.

When ordering replacement parts, be sure to specify your mower model number, part number, description of part, and the number of parts required . . . Parts and service should be handled by your nearest authorized service firm as recommended by your dealer. Request for parts and service received at the factory will be forwarded to the appropriate Central Service Distributor in your area for handling.

901-8500 REVERSING TRANSMISSION

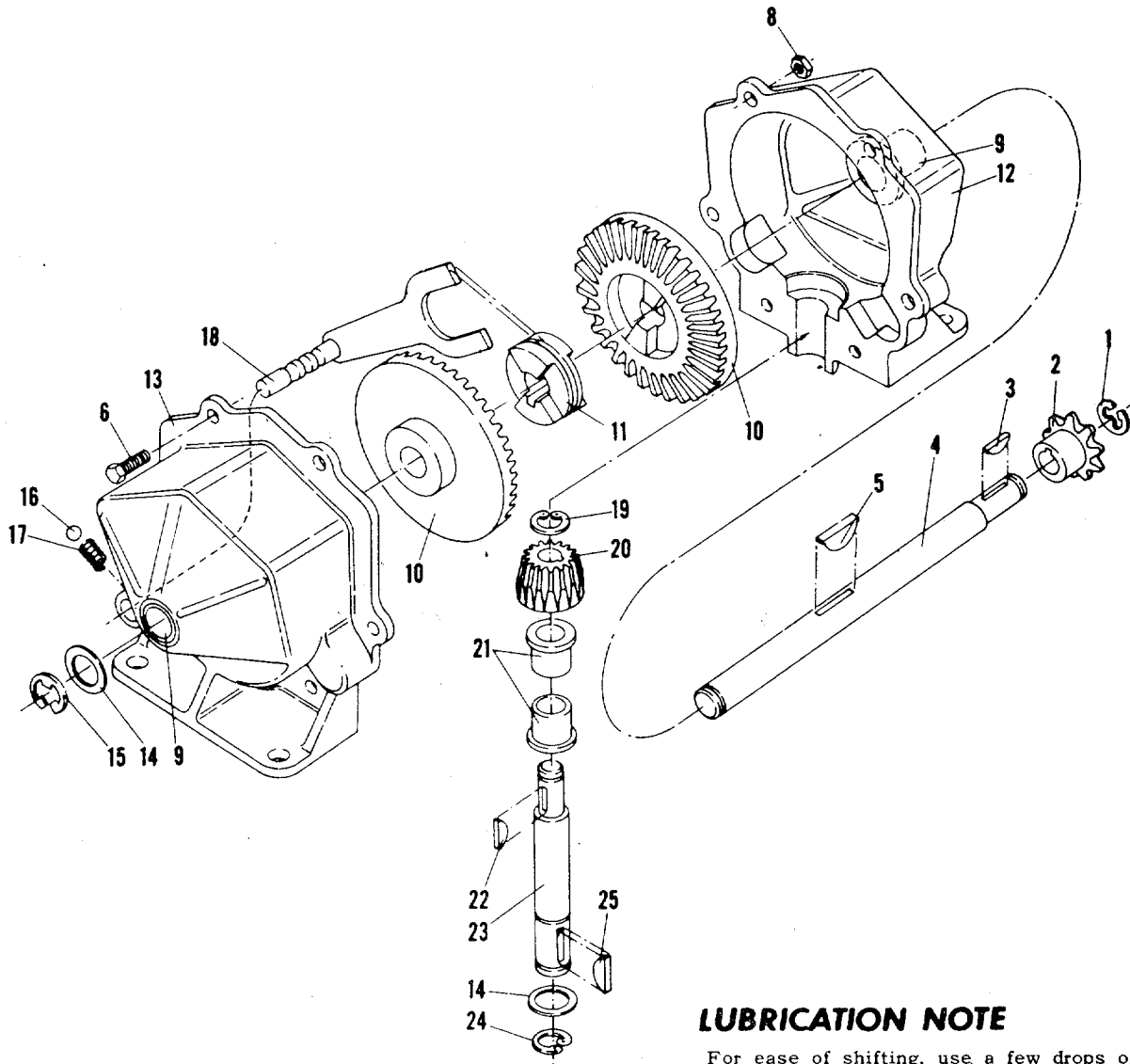

PARTS LIST

Key No.	Part No.	Description	Key No.	Part No.	Description
1	716-104	Snap Ring	14	736-116	Washer
2	748-852	Sprocket 8T, #41	15	716-106	Snap Ring
3	714-110	Key Hi-Pro HP 503	16	741-862	Ball-Detent
4	711-854	Shaft Output	17	732-863	Spring-Detent
5	714-126	Key Hi-Pro #606 Hardened	18	310-8583	Detent Shaft Ass'y
6	710-195	Hex Hd. Cap Screw 1/4-28 x 5/8*	19	716-865	Snap Ring #3100-50
8	712-117	Locknut 1/4-28 thd.	20	748-866	Bevel Pinion
9	748-855	Bearing	21	748-867	Bearing
10	748-856	Bevel Gear	22	714-110	Key Hi-Pro HP 503
11	748-857	Clutch Collar	23	711-869	Shaft Input
12	717-123	Housing Half	24	716-361	Snap Ring
13	717-124	Housing Half with Detent Hole	25	714-868	Key Woodruff #9* Lubriplate 70A 4 ounces

* For faster service obtain standard nuts, bolts and washers locally. If these items cannot be obtained locally, order by part number and size as shown on the parts list.

LUBRICATION NOTE

For ease of shifting, use a few drops of oil as needed.

Transmission is prelubricated with four ounces of Lubriplate No. 310 Grease. Use this or an equivalent if service is necessary.

Order part number 727-136 for a 4 ounce container of Lubriplate No. 310 grease.

GEAR SHIFTING INSTRUCTIONS

It is sometimes impossible to shift from one position to another if the Clutch Collar (Illus. 11) is not aligned with the Bevel Gear (Illus. 10). In order to mesh the gears and thus permit shifting it is necessary to:

1. Move mower forward or backward if engine is not running.
2. Depress clutch pedal slightly if engine is running.

To be assured of long, trouble free service, it is suggested that the shift lever never be forced into position, and that when the gears are meshed, they are meshed fully and not just part way. Following the above suggestions will eliminate wear which might otherwise take place in the internal area of the transmission gears and Clutch Collar.