

# OWNER'S GUIDE

OUTDOOR POWER EQUIPMENT  
for all seasons

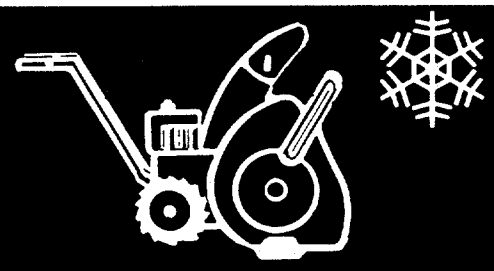
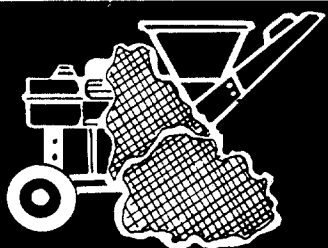
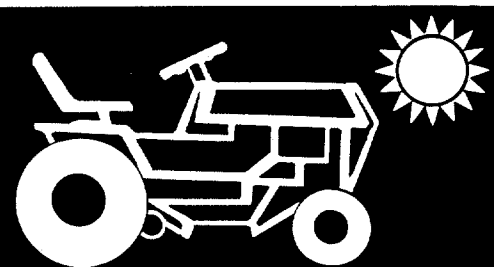

## 21" ROTARY MOWERS

### Model Numbers

- |             |             |
|-------------|-------------|
| 128-464R000 | 128-474R000 |
| 128-465R000 | 128-475R000 |
| 128-466R000 | 128-476R000 |
| 128-468R000 | 128-478R000 |
| 128-469R000 | 128-479R000 |

*128-476E000*

*(SEE SUPPLEMENT)*

**IMPORTANT:**  
Read Safety Rules and  
Instructions Carefully

Thank you for purchasing  
an American-built product.

# INDEX

Slope Gauge .....	3
Contents of Hardware Pack .....	4
Rules for Safe Operation .....	5
Assembly .....	6
Controls .....	13
Operation .....	14
Adjustments .....	16
Lubrication .....	16
Maintenance .....	17
Off-Season Storage .....	18
Illustrated Parts .....	20, 23, 24
Repair Parts List .....	21, 22, 23, 24
Trouble Shooting Chart .....	25
Parts Information .....	Back Cover

Dear Customer,

So often throughout the year we are all in a rush to meet our daily obligations.

However, we at MTD Products Inc are taking a quick moment out to say . . .

**"Thank you for your business."**

Sincerely,  
MTD PRODUCTS INC



**INSTRUCTIONS GIVEN WITH THIS SYMBOL ARE FOR PERSONAL SAFETY. BE SURE TO FOLLOW THEM.**

## LIMITED WARRANTY

For one year from the date of original retail purchase, MTD PRODUCTS INC will either repair or replace, at its option, free of charge, F.O.B. factory or authorized service firm, any part or parts found to be defective in material or workmanship. Transportation charges for the movement of any power equipment unit or attachment are the responsibility of the purchaser. Transportation charges for any parts submitted for replacement under this warranty must be paid by the purchaser unless such return is requested by MTD PRODUCTS INC.

This warranty will not apply to any part which has become inoperative due to misuse, excessive use, accident, neglect, improper maintenance, alterations, or unless the unit has been operated and maintained in accordance with the instructions furnished. This warranty does not apply to the engine, motor, battery, battery charger or component parts thereof. Please refer to the applicable manufacturer's warranty on these items.

This warranty will not apply where the unit has been used commercially.

Warranty service is available through your local authorized service dealer or distributor. If you do not know the dealer or distributor in your area, please write to the Customer Service Department of MTD.

The return of a complete unit will not be accepted by the factory unless prior written permission has been extended by MTD.

This warranty gives you specific legal rights. You may also have other rights which vary from state to state.

**WARNING:** This unit is equipped with an internal combustion engine and should not be used on or near any unimproved forest-covered, brush-covered or grass-covered land unless the engine's exhaust system is equipped with a spark arrester meeting applicable local or state laws (if any). If a spark arrester is used, it should be maintained in effective working order by the operator.

In the State of California the above is required by law (Section 4442 of the California Public Resources Code). Other states may have similar laws. Federal laws apply on federal lands. A spark arrester for the muffler is available through your nearest engine authorized service center.

Cut Along This Line

USE THIS SHEET AS A GUIDE TO DETERMINE SLOPES WHERE YOU MAY NOT OPERATE SAFELY.

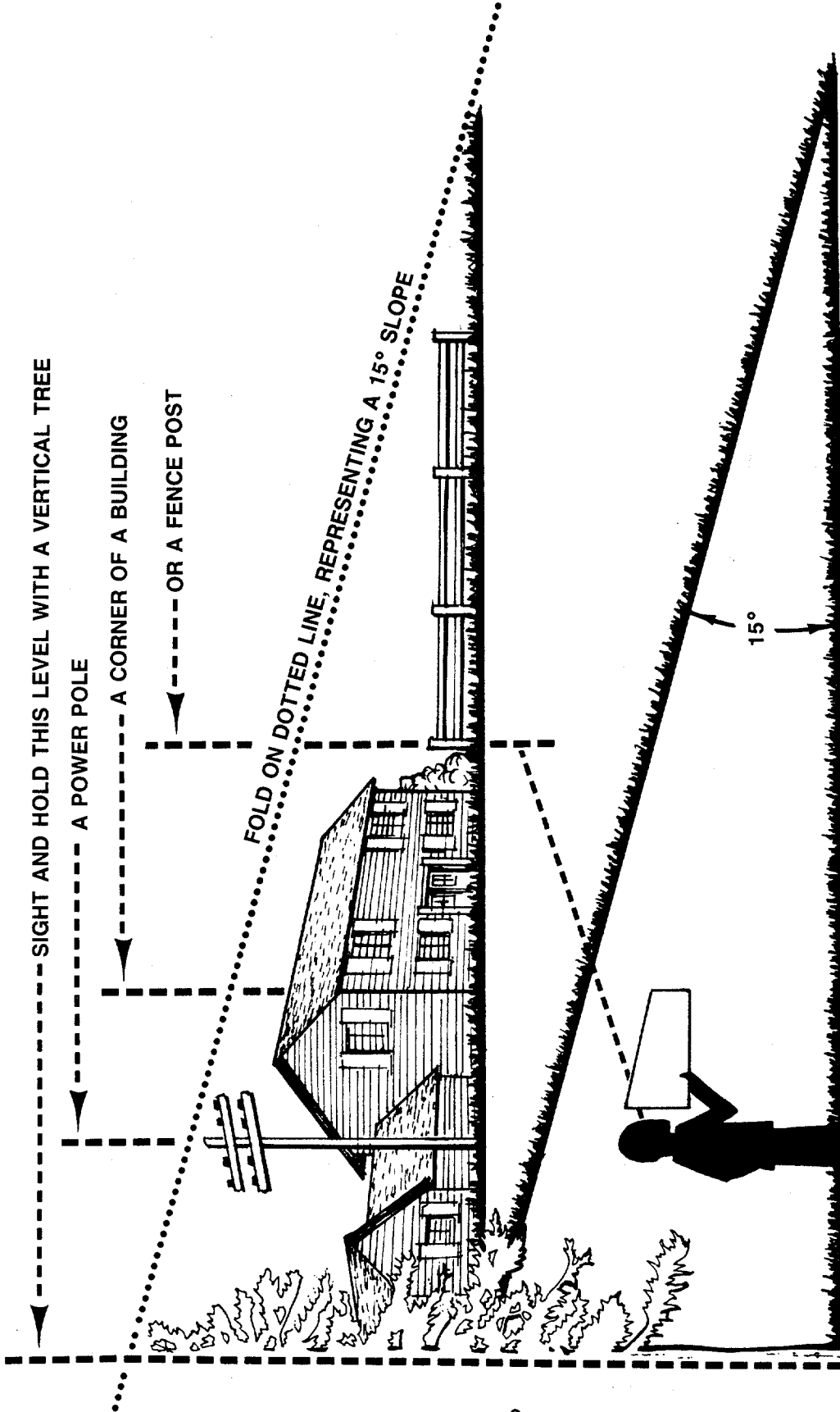

Do not mow on inclines with a slope in excess of 15 degrees (a rise of approximately 2½ feet every 10 feet). A riding mower could overturn and cause serious injury. If operating a walk-behind mower on such a slope, it is extremely difficult to maintain your footing and you could slip, resulting in serious injury.

Operate RIDING mowers up and down slopes, never across the face of slopes.

Operate WALK-BEHIND mowers across the face of slopes, never up and down slopes.

# CONTENTS OF HARDWARE PACK/PARTS IDENTIFICATION

Remove this sheet from your owner's manual and lay the hardware on the illustration for identification purposes. After assembly, keep the Slope Gauge which is on the reverse side of this sheet for future use.  
 (Hardware pack may contain extra items which are not used on your unit.)

**A ATTACHING THE LOWER HANDLE**

Hairpin Clips

**B ATTACHING THE UPPER HANDLE**

Rope Guide Bolt

Curved Head Bolt

Split Washers 5/16" I.D.

Hex Nuts 5/16-18 Thread

**C ATTACHING THE DRIVE CLUTCH CONTROL CABLE**

Phillips Head Screws

Plastic Cap

**D SECURING THE CABLES**

Cable Ties

**E ASSEMBLY OF GRASS CATCHER**  
 Models 464R through 469R  
 (Soft Grass Bags):

Self-Tapping Screws

Models 474R through 479R  
 (Hardtop Grass Bags):

Truss Machine Screws 1/4-20 x 1" Long

Mounting Clips

Flat Washers 1/4" I.D. x 5/8" O.D.

Hex Nuts 1/4-20 Thread

Self-Tapping Screws

Cut Along This Line



# IMPORTANT

## RULES FOR SAFE OPERATION



THIS SYMBOL POINTS OUT IMPORTANT SAFETY INSTRUCTIONS WHICH, IF NOT FOLLOWED, COULD ENDANGER THE PERSONAL SAFETY AND/OR PROPERTY OF YOURSELF AND OTHERS. READ AND FOLLOW ALL INSTRUCTIONS IN THIS MANUAL BEFORE ATTEMPTING TO OPERATE YOUR LAWN MOWER. FAILURE TO COMPLY WITH THESE INSTRUCTIONS MAY RESULT IN PERSONAL INJURY. WHEN YOU SEE THIS SYMBOL—  **HEED ITS WARNING.**



**DANGER**

Your lawn mower was built to be operated according to the rules for safe operation in this manual. As with any type of power equipment, carelessness or error on the part of the operator can result in serious injury. If you violate any of these rules, you may cause serious injury to yourself or others.



### TRAINING

1. Read this owner's manual carefully in its entirety before attempting to assemble or operate this machine. Be completely familiar with the controls and the proper use of this machine before operating it. Keep this manual in a safe place for future and regular reference and for ordering replacement parts.
2. Your rotary mower is a precision piece of power equipment, not a plaything. Therefore, exercise extreme caution at all times.
3. Never allow children to operate a power mower. Only persons well acquainted with these rules of safe operation should be allowed to use your mower.
4. Keep the area of operation clear of all persons, particularly small children and pets. Stop engine when they are in the vicinity of your mower to help prevent blade contact or thrown object injury. Although the area of operation should be completely cleared of foreign objects, an object may have been overlooked and could be accidentally thrown by the mower in any direction and cause serious personal injury to the operator or any others allowed in the area.



### PREPARATION

1. Thoroughly inspect the area where the equipment is to be used. Remove all stones, sticks, wire, bones and other foreign objects which could be picked up and thrown by the mower in any direction and cause serious personal injury to the operator or any others allowed in the area.
2. Always wear safety glasses or eye shields during operation or while performing an adjustment or repair, to protect eyes from foreign objects that may be thrown from the machine in any direction.
3. Wear sturdy, rough-soled work shoes and close-fitting slacks and shirts to avoid entanglement in the moving parts. Never operate a unit in bare feet, sandals, or sneakers.
4. Check the fuel before starting the engine. Gasoline is an extremely flammable fuel. Do not fill the gasoline tank indoors, while the engine is running, or until engine has been allowed to cool for two minutes after running. Replace gasoline cap securely and wipe off any spilled gasoline before starting the engine as it may cause a fire or explosion.
5. Disengage the self-propelled mechanism or drive clutch on units so equipped before starting the engine.
6. The blade control handle is a safety device. Never attempt to bypass its operation. Doing so makes the safety device inoperative and may result in personal injury through contact with the rotating blade. The blade control handle must operate easily in both directions.
7. Never attempt to make a wheel or cutting height adjustment while the engine is running.
8. Never operate the equipment in wet grass. Always be sure of your footing. A slip and fall can cause serious personal injury. Keep a firm hold on the handle and walk, never run. Mow only in daylight or in good artificial light.



### OPERATION

1. Do not change the engine governor settings or overspeed the engine. Excessive engine speeds are dangerous.
2. Do not put hands or feet near or under rotating parts. Keep clear of the discharge opening at all times as the rotating blade can cause injury.
3. Stop the blade when crossing gravel drives, walks or roads.
4. After striking a foreign object, stop the engine, remove the wire from the spark plug, and thoroughly inspect the mower for any damage. Repair the damage before restarting and operating the mower.
5. If the equipment should start to vibrate abnormally, stop the engine and check immediately for the cause. Vibration is generally a warning of trouble.
6. Shut the engine off and wait until the blade comes to a complete stop before removing the grass catcher or unclogging the chute. The cutting blade continues to rotate for a few seconds after the engine is shut off. Never place any part of the body in the blade area until you are sure the blade has stopped rotating.
7. Before cleaning, repairing or inspecting, make certain the blade and all moving parts have stopped. Disconnect the spark plug wire, and keep the wire away from the spark plug to prevent accidental starting.
8. Do not run the engine indoors.
9. Mow across the face of slopes, never up-and-down. Exercise extreme caution when changing direction on slopes. Do not mow excessively steep slopes. Always be sure of your footing. A slip and fall can cause serious personal injury.
10. Never operate mower without proper guards, plates or other safety protective devices in place.
11. Do not operate this mower with the chute door open, unless the complete grass catcher is properly mounted on the mower.



### MAINTENANCE AND STORAGE

1. Check the blade and engine mounting bolts at frequent intervals for proper tightness.
2. Keep all nuts, bolts, and screws tight to be sure the equipment is in safe working condition.
3. Never store the equipment with gasoline in the tank inside of a building where fumes may reach an open flame or spark. Allow the engine to cool before storing in any enclosure.
4. To reduce fire hazard, keep the engine free of grass, leaves, or excessive grease.
5. Check the grass catcher bag frequently for wear or deterioration. For safety protection, replace only with new bag meeting original equipment specifications.

➔ **IMPORTANT:** This unit is shipped **WITHOUT GASOLINE** or **OIL**. After assembly, service engine with gasoline and oil as instructed in the separate engine manual packed with your unit.

➔ **NOTE:** Reference to right or left hand side of the mower is observed from the operating position.

## ASSEMBLY INSTRUCTIONS

### Tools Required for Assembly

- (1) Pair of Pliers
- (1) 1/2" Wrench\*
- (1) 5/16" Wrench or Nutdriver\*
- (1) Phillips Screwdriver
- (1) Flat Blade Screwdriver
- \*Or one 6" Adjustable Wrench.

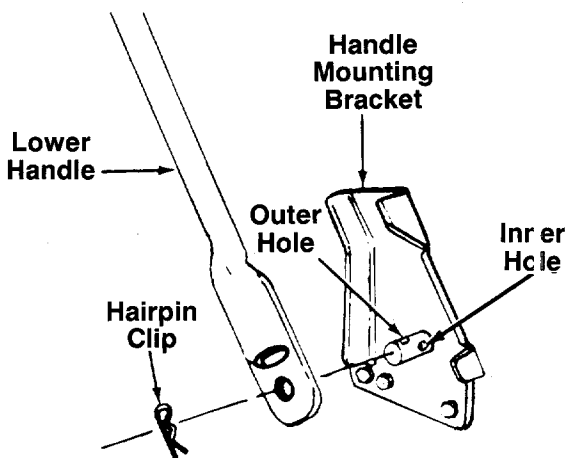

FIGURE 1.

### UNPACKING

1. Remove the lawn mower from the carton by opening the top flaps and lifting the unit out. Be careful of the staples. Make certain all parts and literature have been removed from the carton before the carton is discarded.
2. Disconnect and ground the spark plug wire against the engine. Check beneath the deck for any cardboard packaging. Remove if present.
3. Stretch out all control cables and place on the floor. Be careful not to bend or kink the cables at any time during assembly.
4. Remove page four from this manual and lay the contents of the hardware pack on the illustration for identification.

### ATTACHING THE LOWER HANDLE (Hardware A)

1. Attach the lower handle by placing the bottom holes in the lower handle over the weld pins on the handle mounting brackets on the rear of the deck. Make certain the instruction label on the lower handle can be read from the operating position.
2. Using a pair of pliers, squeeze one leg of the lower handle against the handle mounting bracket. Insert the hairpin clip into the **inner hole** on the weld pin. See figure 1. Repeat on other side.

➔ **NOTE**

There are two (2) holes in the handle mounting brackets. Place the hairpin clip in the inner hole for operation. Outer hole is for storage.

### ATTACHING THE UPPER HANDLE (Hardware B)

1. Place the upper handle in position over the lower handle. **The label on the throttle control housing and the control lever must be facing up.**

➔ **NOTE**

The right hand side of the handle will be secured with the rope guide bolt. However, left handed operators may assemble the rope guide bolt to the left side of the handle for easier starting by following steps 2 and 3 and reversing the left and right hand instructions.

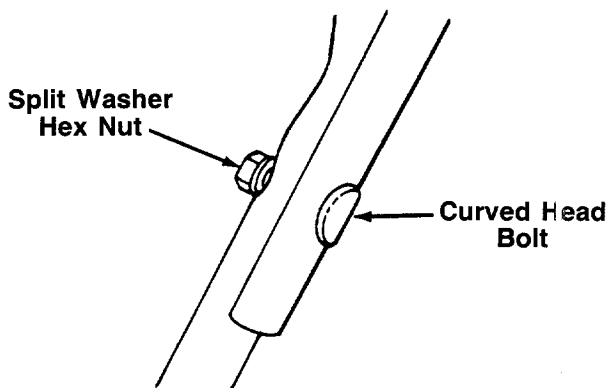

FIGURE 2.

2. Secure the left hand side of upper handle using the curved head bolt, split washer and hex nut as shown in figure 2.

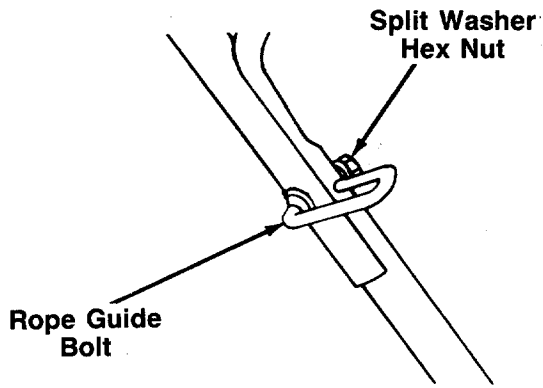

FIGURE 3.

3. Insert the rope guide bolt through the right hand side of upper and lower handle. See figure 3. Secure with split washer and hex nut, finger tight only.

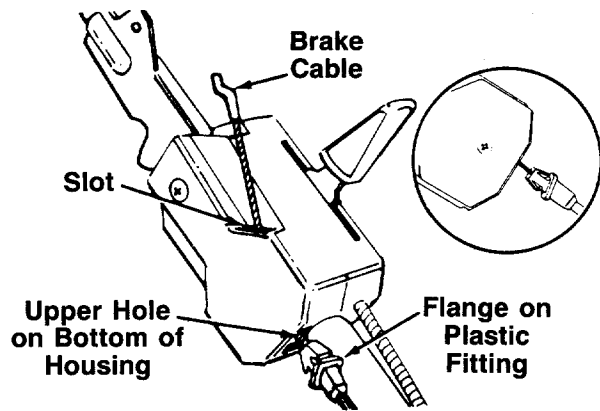

FIGURE 4.

### ATTACHING THE BRAKE CABLE

1. The brake cable is attached to the engine, and has a "Z" fitting on the loose end. Route the brake cable below the lower handle. Place end of cable into the upper hole on the bottom of the control housing, and through the slot as shown. The angle of the plastic flange must be positioned downward as shown in figure 4. Be careful not to bend or kink the cable at any time.
2. Push the plastic fitting until it locks into the control housing.



Brake cable must be assembled as shown for proper blade brake operation.

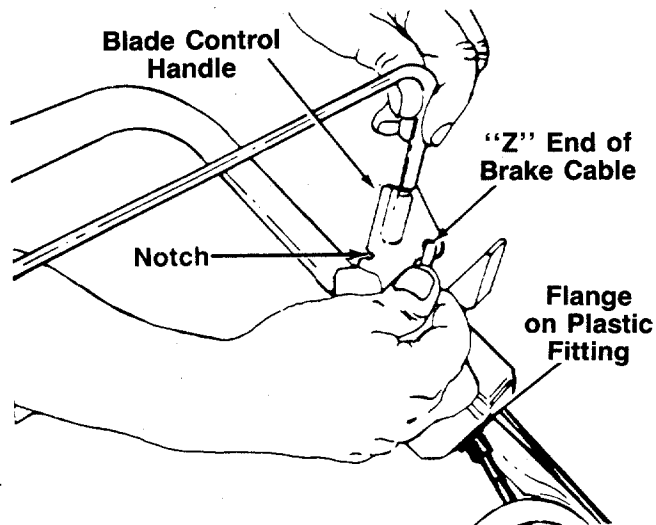

FIGURE 5.

3. Hook the "Z" end of the brake cable into the hole in the blade control handle from the inside to the outside as shown in figure 5.

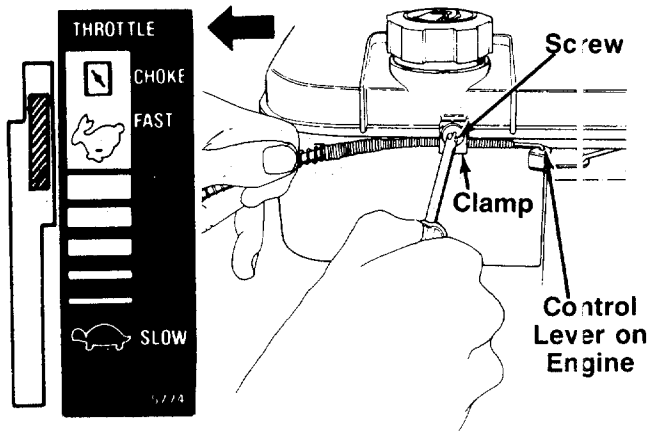

FIGURE 6A.—Models 464R & 474R

#### ATTACHING THE THROTTLE CABLE

##### Models 464R and 474R Only:

1. Push the throttle control lever on the handle all the way forward to CHOKE, then back it off **two "clicks"** (approximately 5/16"). See figure 6A.
2. The throttle control cable is attached to the upper handle. Route the throttle control cable under the lower handle and inside the handle mounting bracket. Hook the "Z" end of the throttle control cable into the hole in the control lever on the engine. See figure 6A.
3. Using a screwdriver, remove the screw on the cable clamp shown in figure 6A. Slip the control cable under the clamp. Replace the screw, but do not tighten (cable must still move freely beneath the clamp).
4. Push the control lever on the engine as far toward the **rear** of the engine as it will go. See figure 6A. Pull the throttle control cable toward the rear of the engine to remove any slack in the cable as you tighten the screw.

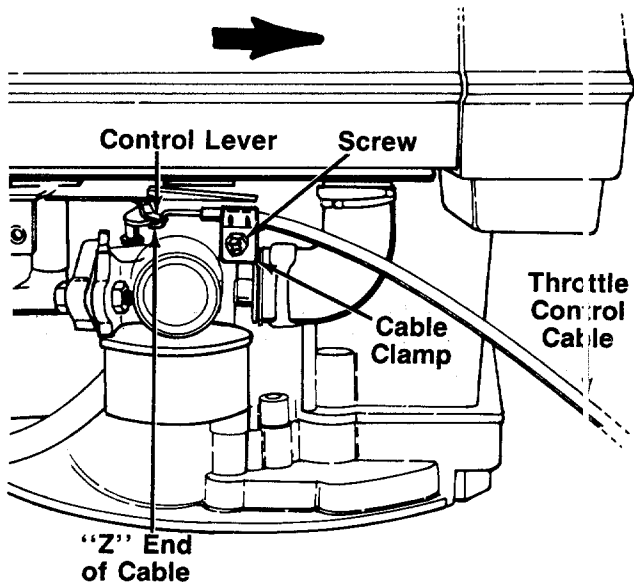

FIGURE 6B.—Models 465R, 468R, 475R and 478R

#### ATTACHING THE THROTTLE CABLE

##### Models 465R, 468R, 475R and 478R Only:

1. Place the throttle control lever on the handle in FAST position.
2. The throttle control cable is attached to the upper handle. Route the throttle control cable under the lower handle and inside the handle mounting bracket. Hook the "Z" end of the throttle control cable into the control lever on the engine as shown in figure 6B.
3. Loosen (do not remove) the screw on the cable clamp shown in figure 6B. Slip the control casing under the clamp (cable must move freely beneath the clamp).
4. Place the control lever on the engine in the full open position by pushing it as far toward the **rear** of the unit as it will go. Tighten the screw on the cable clamp to secure the cable in this position.



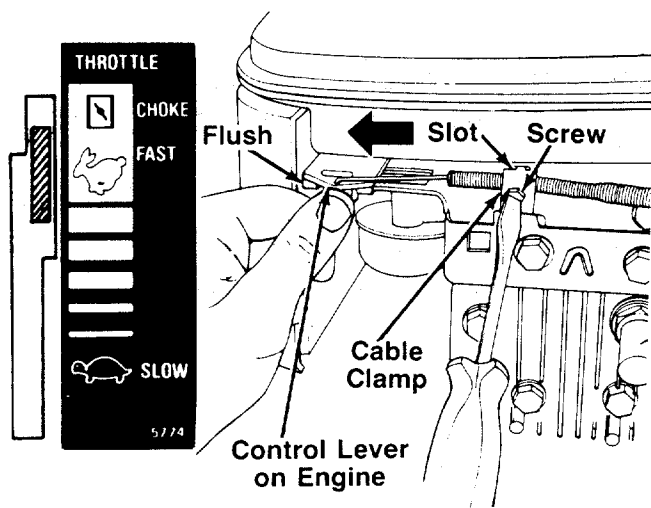

FIGURE 6C.—Models 466R, 469R, 476R and 479R

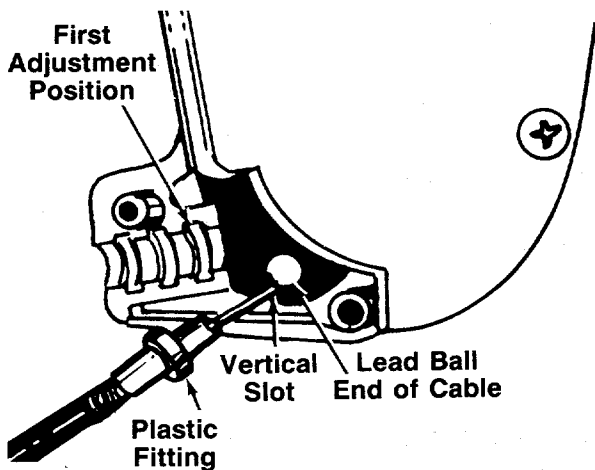

FIGURE 7.

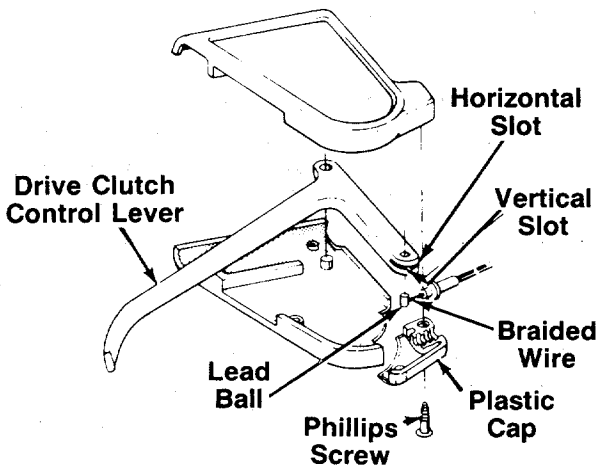

FIGURE 8.

### ATTACHING THE THROTTLE CABLE

Models 466R, 469R, 476R and 479R Only:

1. Push the throttle control lever on the handle all the way forward to CHOKE, then back it off two "clicks" (approximately 5/16"). See figure 6C.
2. The throttle control cable is attached to the upper handle. Route the throttle control cable under the lower handle and inside the handle mounting bracket. Hook the "Z" end of the throttle control cable into the hole in the control lever on the engine. See figure 6C.
3. Using a 5/16" wrench or nutdriver, remove the screw on the cable clamp shown in figure 6C. Slip the control cable under the clamp. Replace the screw (cable should be above the screw), but do not tighten (cable must still move freely beneath the clamp). Make certain the tab on the cable clamp is seated into the slot on the engine.
4. Push the control lever on the engine as far toward the **outside** of the engine as it will go. The edge of the control lever should be flush with the bracket on the engine. See figure 6C. Hold the control lever in this position as you tighten the screw on the cable clamp to secure the throttle cable.
5. Loosen the screw on the clamp on the side of the engine. Slip the cable casing under the clamp to secure the cable **away from the muffler**. Be careful not to bend or kink the cable. Tighten the screw.

### ATTACHING THE DRIVE CLUTCH CONTROL CABLE (Hardware C)

The drive clutch control cable is attached to the deck. Attach the cable to the lever in the clutch control housing, located in the middle of the upper handle, as follows.

1. Place the lead ball end of the cable into the fitting provided in the end of the clutch control lever. Slip the braided wire into the vertical slot as shown in figure 7.
2. Slide the braided wire around in the horizontal slot. See figure 8.
3. Place the plastic fitting on the control cable into the first adjustment position in the clutch control housing. See figure 7.
4. Secure the plastic cap to the clutch control housing using the two Phillips head screws. See figure 8.



**WARNING**

Drive clutch adjustment must be checked before the unit is operated, as described in the operation section.

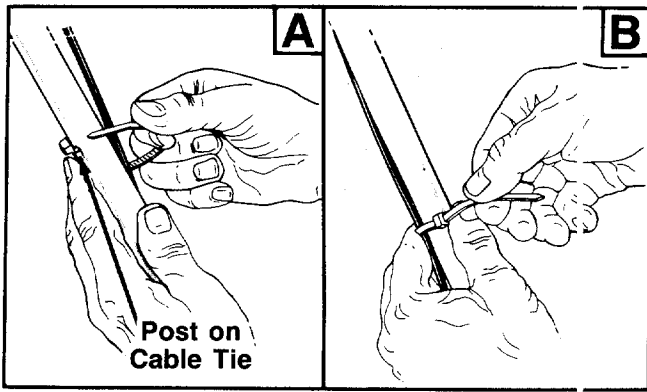

FIGURE 9.

**SECURING THE CABLES (Hardware D)**

Secure all cables to the left side of the handle as follows.

- A. Insert posts on cable ties into holes provided on the lower handle. The holes may be either on the inside or outside of the handles. See figure 9A.
- B. Secure the cables with the cable ties. See figure 9B.
- C. Trim excess ends of cable ties.

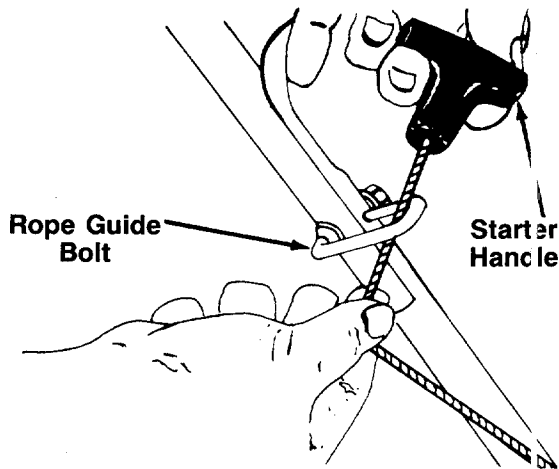

FIGURE 10.

**ATTACHING THE STARTER ROPE**

1. The starter rope is protruding from the top of the engine. Additional rope may be wound around the starter handle. If so, unwind the rope from the handle.
2. With the spark plug wire disconnected and grounded, depress the blade control handle and pull the rope out of the engine.
3. Slip the starter rope into the rope guide bolt as shown in figure 10.
4. Tighten the hex nut on the rope guide bolt securely.

**FINAL ASSEMBLY OF MOWER**

1. Attach hub caps (optional) to the wheels by lining up the tabs on the hub caps with the holes in the wheels. Push to lock in position.
2. Make certain all nuts and bolts are tightened securely.

**ASSEMBLY OF GRASS CATCHER (Hardware E)**

There are two different types of grass catchers, those with soft grass bags and those with hardtop grass bags. Follow the instructions which pertain to your unit.

**Models 464R through 469R (Soft Grass Bags):**

1. Place the end of the rear frame inside the grass catcher bag. See figure 11A.
2. Insert one end of the frame into the cloth channel inside the grass catcher bag. Feed all the material on one side of the frame before working it around the frame.

When this step is completed, both ends of the frame should be inside the bag. See figure 11B.

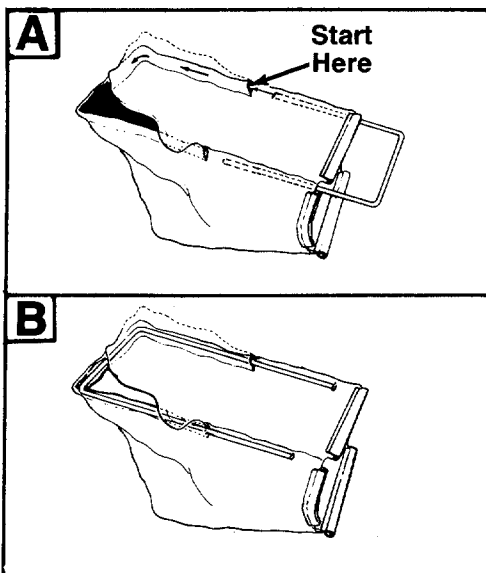

FIGURE 11.

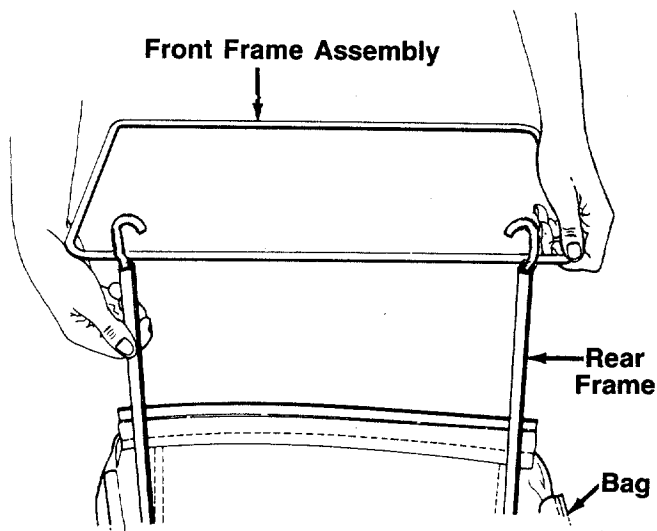

FIGURE 12.

3. Join the rear frame and front frame assembly as shown in figure 12.

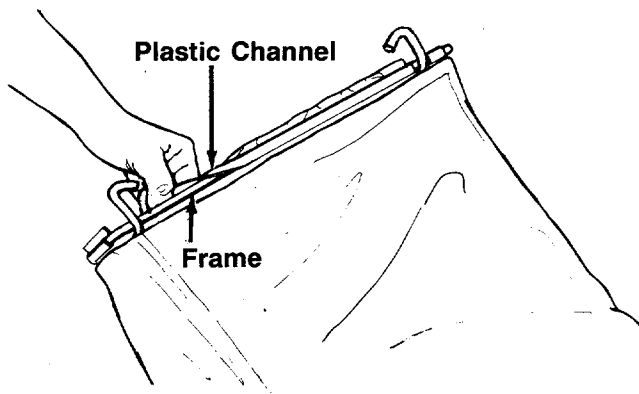

FIGURE 13.

4. Secure front of bag to frame by working the plastic channels on bag over frame. See figure 13.

5. Close the top of the bag by stretching the loose material over the end of the frame.



**WARNING**

Never operate the mower with the bag open.

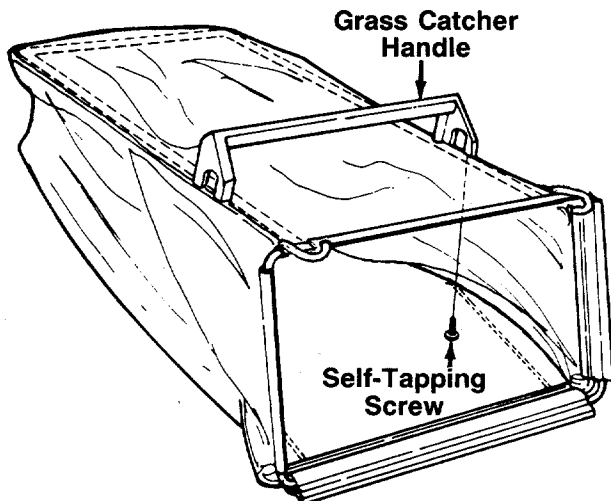

FIGURE 14.

6. Place the grass catcher handle in position on top of the grass bag and frame as shown in figure 14. Secure with four self-tapping screws.

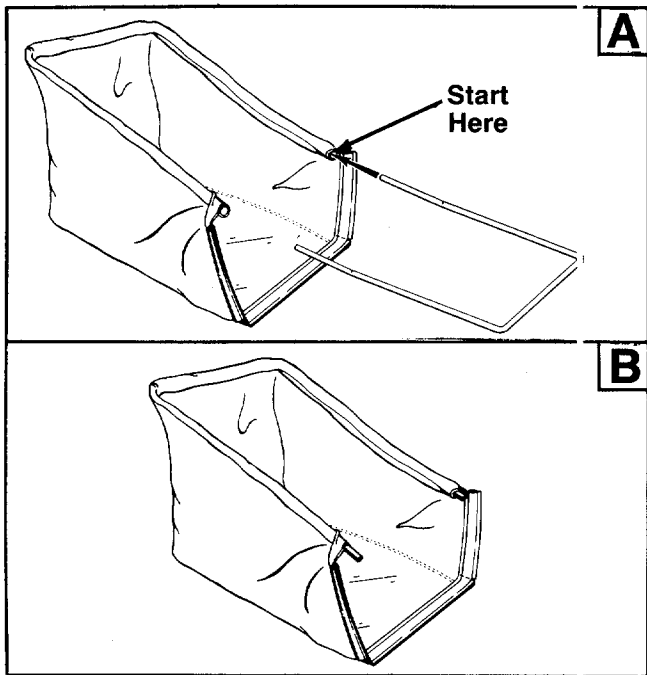

FIGURE 15.

**Models 474R through 479R (Hardtop Grass Bags):**

1. Insert one end of the rear frame into the cloth channel on the edge of the grass catcher bag. Feed all the material on one side of the frame before working it around the frame. See figure 15.

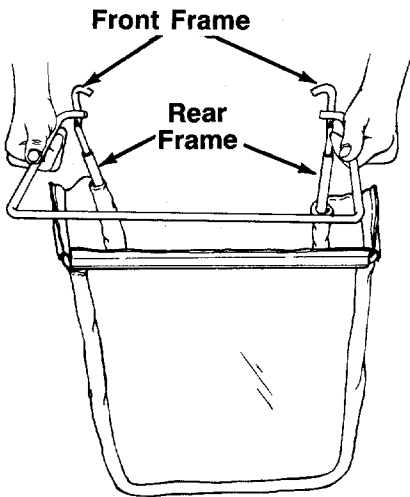

FIGURE 16.

2. Slide the ends of the front frame assembly into the ends of the rear frame as shown in figure 16.

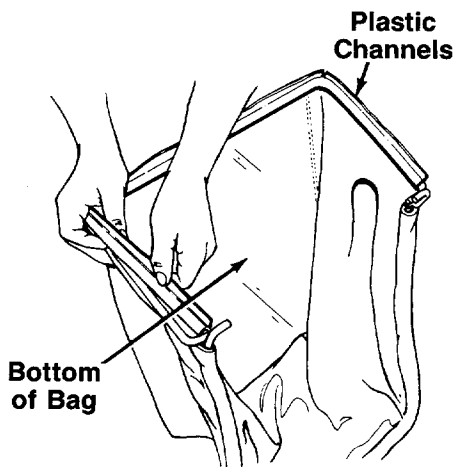

FIGURE 17.

3. Secure front of bag to front frame by slipping plastic channels on sides and bottom of bag over frame. See figure 17.



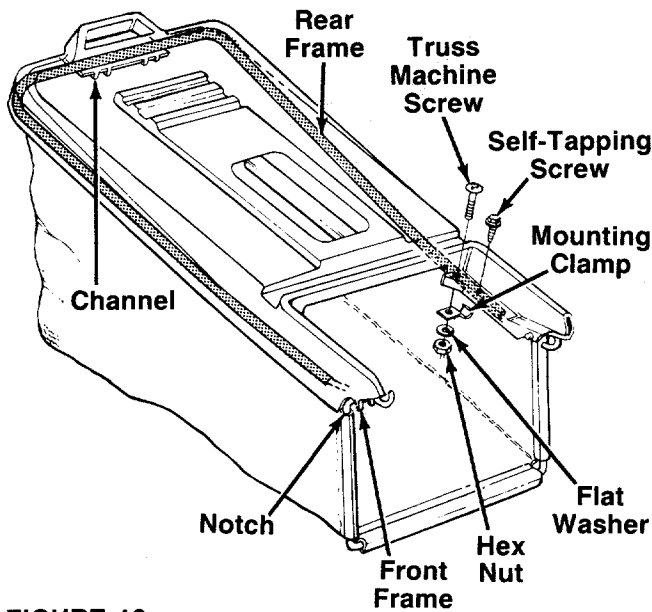

FIGURE 18.

4. Attach the hardtop cover to the grass catcher as follows. See figure 18.
- Place the cover in position on top of the grass catcher. Press the rear frame into the channel on the rear of the cover (beneath the rear handle).
  - Slide the notches on the sides of the cover over the front catcher frame.
  - Place truss machine screw down through hole in cover. Place mounting clip over truss machine screw, with the cupped part of the mounting clip beneath the frame of the grass catcher. Secure with flat washer and hex nut. Repeat on other side of grass catcher.
  - Attach cover to frame using self-tapping screws as shown in figure 18.

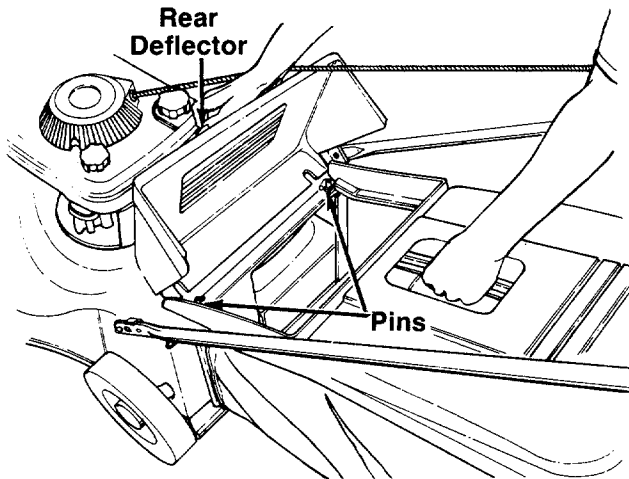

FIGURE 19.

**ATTACHING BAG TO MOWER**

Lift the rear deflector on the mower. Place the hooks on the grass catcher over the pins on the back of the mower. See figure 19. Release the rear deflector.

To remove the grass catcher, lift the rear deflector on the mower. Lift the grass catcher up, over the pins on the back of the mower. Release the rear deflector.

**CONTROLS**

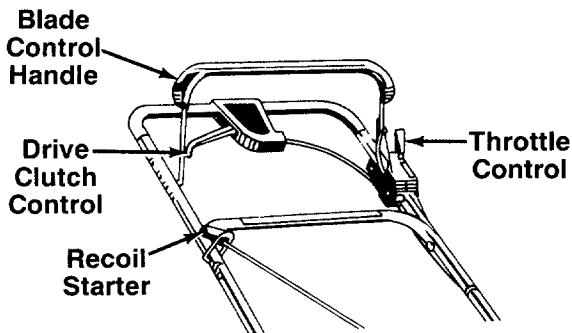

FIGURE 20.

**BLADE CONTROL HANDLE**

**WARNING**  
**THIS CONTROL MECHANISM IS A SAFETY DEVICE NEVER ATTEMPT TO BYPASS ITS OPERATIONS**

The blade control handle is located on the upper handle of the mower. See figure 20. The blade control handle must be depressed in order to operate the unit. Release the blade control handle to stop the engine and blade.



The blade will be rotating whenever the engine is running.

## THROTTLE CONTROL

The throttle control is located on the side of the upper handle. It is used to regulate the engine speed.



The throttle control cannot be used to stop the engine.

## RECOIL STARTER

The recoil starter handle is attached to the handle. See figure 20. Stand behind the unit in the operating position to start the unit.

## DRIVE CLUTCH CONTROL

Squeezing the drive clutch control engages the drive mechanism to the rear wheels. Releasing the clutch control stops the rear wheels from driving. Release the drive clutch control to slow down when negotiating an obstacle, making a turn or stopping. See figure 20.

## OPERATION



FIGURE 21.

Keep hands and feet away from the chute area on cutting deck. See figure 21.

### NOTE

For shipping purposes your mower is set with the wheels in a low cutting height position. For best results raise the cutting position until it is determined which height is best for your lawn. See cutting height adjustment section.

## GAS AND OIL FILL-UP

Service the engine with gasoline and oil as instructed in the separate engine manual packed with your mower. Read instructions carefully.



Never fill fuel tank indoors, with engine running or until the engine has been allowed to cool for at least two minutes after running.

## BEFORE STARTING

1. Attach spark plug wire to spark plug. If unit is equipped with a rubber boot over the end of the spark plug wire, make certain the metal loop on the end of the spark plug wire (inside the rubber boot) is fastened securely over the metal tip on the spark plug. See figure 22.

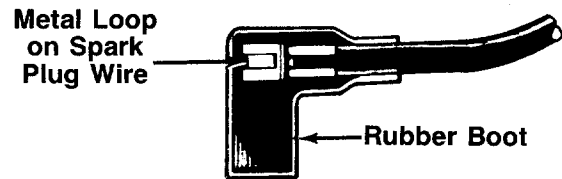

FIGURE 22.

2. Models 464R, 466R, 469R, 474R, 476R and 479R only: Open fuel shut-off valve. See figure 23.

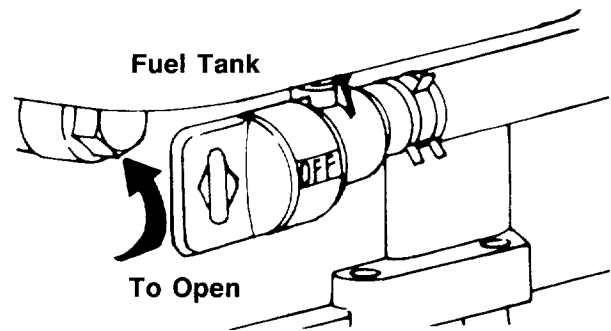

FIGURE 23A.—Models 466R, 469R, 476R & 479R

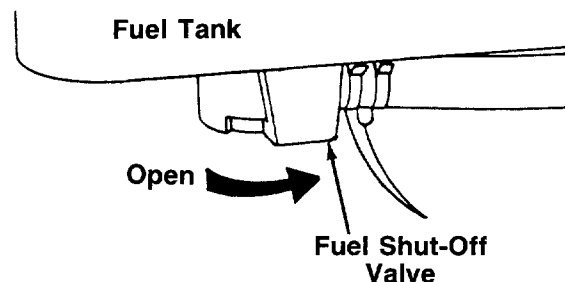

FIGURE 23B.—Models 464R and 474R

3. Before each use, check for proper drive clutch operation by performing the following before starting the engine:

With the drive clutch control released, push mower forward. It should move freely. Pull mower backward. It should move freely.

If it does not and the rear wheels tend to lock up, the clutch may not be releasing completely. Do not start the engine until corrections have been made. Check the control cable for severe bend, kinks and binding, or grass build-up in the pulley groove. Correct and adjust as required.

### TO START ENGINE AND ENGAGE BLADE



When starting the unit for the first time, face the mower against a solid object such as a wall, fence, etc. Start the unit, and if it shows any signs of motion with the drive clutch control disengaged, shut the engine off immediately. Check the position of the drive clutch control cable. The plastic fitting must be assembled in the first adjustment position inside the housing, all the way to the right, as shown in figure 7.

1. **Models 464R, 466R, 469R, 474R, 476R and 479R:** Move throttle control lever to CHOKE position.

**All other units:** Move the throttle control lever to FAST or START position.

2. **Tecumseh engines only:** Prime engine as instructed in the separate engine manual packed with your unit.
3. Standing behind the unit, depress the blade control handle and hold it against the upper handle as shown. See figure 24.
4. Grasp the recoil starter handle and pull back rapidly, extending rope fully. Return it slowly to the rope guide bolt.
5. After engine starts, move throttle control to desired engine speed.

#### ➔ NOTE

If any problems are encountered, refer to the Trouble Shooting Chart on page 25.

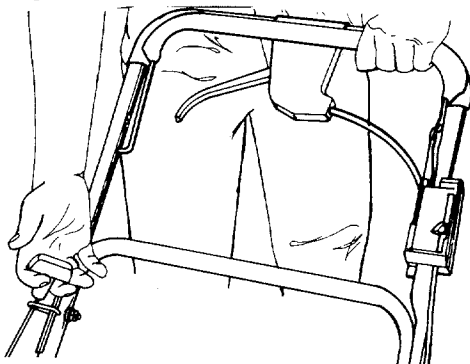

FIGURE 24.

### TO STOP ENGINE AND BLADE

1. Release the blade control handle to stop the engine and blade.



The blade continues to rotate for a few seconds after the engine is shut off.

2. Disconnect the spark plug wire and ground it against the engine to prevent accidental starting while equipment is unattended.

### USING YOUR ROTARY MOWER



Never operate your unit without either the rear deflector or entire grass catcher assembly in place.

Be sure that lawn is clear of stones, sticks, wire, or other objects which could damage lawn mower or engine. Such objects could be accidentally thrown by the mower in any direction and cause serious personal injury to the operator and others.

Operate a new engine at intermediate speeds and light load for the first few hours as you would a new automotive engine.

For the best results, do not cut wet grass because it tends to stick to the underside of the mower, preventing proper discharge of grass clippings, and could cause you to slip and fall. New grass, thick grass or wet grass may require a narrower cut. Blade speed should be adjusted to the condition of the lawn.

For best results, cut off one-third or less of the total length of the grass. Lawn should be cut in the fall as long as there is growth.

This mower is designed to be operated at full throttle to give you the best cut and do the most effective job of bagging the cut grass.

#### ➔ IMPORTANT

If you strike a foreign object, stop the engine. Remove wire from spark plug, thoroughly inspect the mower for any damage, and repair the damage before restarting and operating the mower. Extensive vibration of the mower during operation is an indication of damage. The unit should be promptly inspected and repaired.

## ADJUSTMENTS



**WARNING**

Do not at any time make any adjustment to lawn mower without first stopping engine and disconnecting spark plug wire.

### CUTTING HEIGHT ADJUSTMENT

The height adjustment handle is located on the left side of the deck. The handle may be placed in one of nine cutting height positions. Push the handle to the left and then either forward to lower the cutting height or backward to raise the cutting height. See figure 25.

For rough or uneven lawns, move the height adjustment handle to a position which will give a higher cutting height.

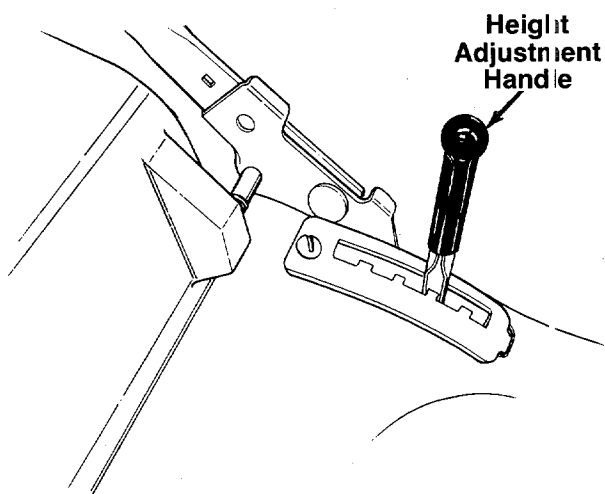

FIGURE 25.

### THROTTLE

The throttle control wire assembly can be adjusted if necessary. Loosen the screw on the cable clamp shown in figure 6. Adjust as instructed in steps 1 and 4 of "Attaching the Throttle Control Cable" in Assembly Instructions.

### CARBURETOR ADJUSTMENTS



**WARNING**

If any adjustments are made to the engine while the engine is running (e.g. carburetor), keep clear of all moving parts. Be careful of heated surfaces and muffler.

**Minor carburetor adjustments may be required to compensate for differences in fuel, temperature, altitude and load.** To adjust carburetor, refer to the separate engine manual.

## NOTE

A dirty air cleaner will cause an engine to run rough. Be certain air cleaner is clean and attached to the carburetor before adjusting carburetor.

## LUBRICATION



**WARNING**

Always stop engine and disconnect spark plug wire before cleaning, lubricating or doing any kind of work on lawn mower.

**Blade Control**—Lubricate the pivot points on the blade control handle and the brake cable at least once a season with light oil. See figure 26. The blade control must operate freely in both directions.

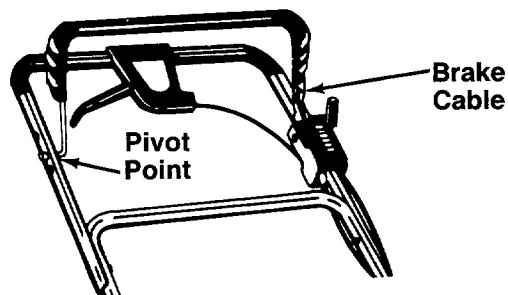

FIGURE 26.

**Discharge Chute Door Mechanism**—The torsion spring and pivot point should be lubricated periodically with light oil to prevent any rust or binding. Door must work freely.

**Wheels**—Lubricate the wheel bearings at least once a season with light oil. Also, if the wheels are removed for any reason, lubricate the surface of the axle bolt and the inner surface of the wheel with light oil. A 4 oz. plastic bottle of light oil lubricant is available. Order part number 737-0170. Engine oil may also be used.

**Throttle**—Periodically lubricate throttle control lever and throttle wire assembly with a few drops of light oil for ease of operation.

**Transmission**—The transmission is pre-lubricated and sealed at the factory. It does not require checking. If disassembled for any reason, fill with 2 ounces of Alvania grease, part number 737-0168.



# MAINTENANCE



## WARNING

Be sure to disconnect and ground the spark plug wire before performing any repairs or maintenance.



## NOTE

When tipping the unit, empty the fuel tank and keep engine spark plug side up.

## TROUBLE SHOOTING

Refer to page 25 of this manual for trouble shooting information.

## CUTTING BLADE

When removing the cutting blade for sharpening or replacement, protect hands by using heavy gloves or a rag to grasp the cutting blade. Remove the bolt and blade bell washer which hold the blade and adapter to the engine crankshaft. Remove the blade and adapter from the crankshaft.



## CAUTION

Periodically inspect the blade adapter for cracks, especially if you strike a foreign object. Replace when necessary.

When sharpening the blade, follow the original angle of grind as a guide. It is **extremely important** that each cutting edge receives an equal amount of grinding to prevent an unbalanced blade. An unbalanced blade will cause excessive vibration when rotating at high speeds, may cause damage to the mower and could break, causing personal injury.

The blade can be tested by balancing it on a round shaft screwdriver. Remove metal from the heavy side until it balances evenly.

Before reassembling the blade and the blade adapter to the unit, lubricate the engine crankshaft, the inner surface of the blade adapter and the center bolt with light oil. A 4 oz. plastic bottle of light oil lubricant is available. Order part number 737-0170. Engine oil may also be used.

When replacing the blade, be sure to install the blade with the side of the blade marked "Bottom" (or with part number) facing the ground when the mower is in the operating position.

## Blade Mounting Torque

Center Bolt: 375 in. lb. min., 450 in. lb. max. If lacking torque wrench, tighten until the blade bell washer is flattened.

To insure safe operation of your unit, **all** nuts and bolts must be checked periodically for correct tightness.

## DECK

The underside of mower deck should be cleaned after each period of use as grass clippings, leaves, dirt and other matter will accumulate. This accumulation of grass clippings, etc., is undesirable as it will invite rust and corrosion and may cause an uneven discharge of grass clippings at the next cutting.

The deck may be cleaned by tilting the mower and scraping clean with a suitable tool or by washing with a stream of water from a garden hose.



## NOTE

Do not direct the stream of water at a hot engine as damage to the engine may result.

## ENGINE

**Refer to the separate engine section for all engine maintenance instructions.**

Maintain **engine oil** as instructed in the separate engine manual packed with your unit. Read and follow instructions carefully.

Service **air cleaner** every 25 hours under normal conditions. Clean every few hours under extremely dusty conditions. Poor engine performance and flooding usually indicates that the air cleaner should be serviced. To service the air cleaner, refer to the separate engine manual packed with your unit.

The **spark plug** should be cleaned and the gap reset once a season. Spark plug replacement is recommended at the start of each mowing season; check engine manual for correct plug type and gap specifications.

**Clean the engine** regularly with a cloth or brush. Keep the cooling system (blower housing area) clean to permit proper air circulation which is essential to engine performance and life. Be certain to remove all grass, dirt and combustible debris from muffler area.

## BELT REMOVAL AND REPLACEMENT

1. Disconnect the spark plug wire and ground it against the engine.
2. Drain the fuel tank or place a piece of plastic beneath the cap to prevent gasoline leakage.
3. Tip the mower back on its handle. Block securely.
4. Remove the rear belt baffle by removing three hex nuts and lock washers, and two carriage bolts. See figure 27.

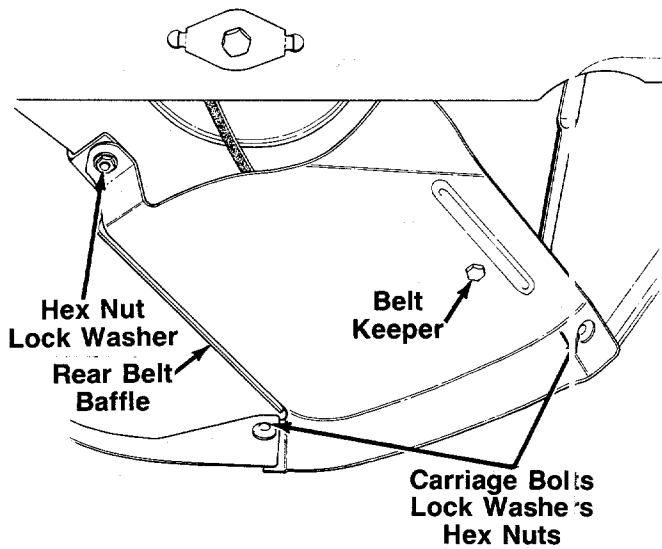

**FIGURE 27.**

5. Roll the belt off the transmission pulley. Remove the belt from between the idler pulley and belt guard. See figure 28.
6. Remove the belt from the pulley on the engine crankshaft, and pull it over the blade.

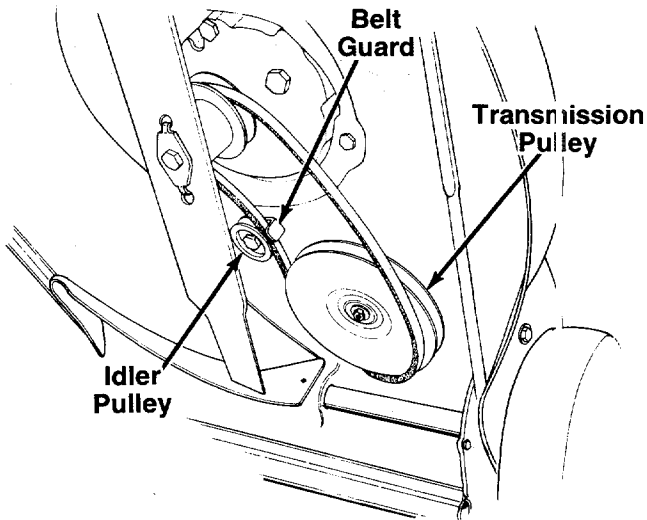

**FIGURE 28.**

7. Reassemble in reverse order with the new belt.

**NOTE**

When reassembling the rear belt baffle, make certain the belt keeper is outside of the belt, and the edge of the rear belt baffle is between the rear chue baffle and the rear panel as shown in figure 27. Make certain to tighten all nuts and bolts securely. If plastic was placed under the gas cap, be certain to remove it.

## OFF-SEASON STORAGE

The following steps should be taken to prepare lawn mower for storage.

1. Clean and lubricate mower thoroughly as described in the lubrication instructions.
2. Refer to engine manual for correct engine storage instructions.
3. Coat mower's cutting blade with chassis grease to prevent rusting.
4. Store mower in a dry, clean area.

**NOTE**

When storing any type of power equipment in an unventilated or metal storage shed, care should be taken to rustproof the equipment. Using a light oil or silicone, coat the equipment, especially cables and all moving parts.

## HANDLE STORAGE

The handle may be placed in an upright position for storage. Move hairpin clips to outer hole on weld pins. See figure 1. Press inward on the bottom of the lower handle and push forward. The handle will lock in this position.

To place the handle in the operating position, remove the starter rope from the rope guide bolt. Grasp the lower handle at the bottom, press inward slightly and tip the handle backward. Place the hairpin clips in the inner holes. With the spark plug wire disconnected and grounded, depress the blade control handle and pull the starter rope out from the engine. Slip the starter rope into the rope guide bolt.

 **NOTE**

The use of any accessory on this Rotary Mower other than those manufactured by the mower manufacturer is **not** recommended.



1. DO NOT operate the mower without the entire grass catcher or chute deflector in place.
2. DO NOT operate the mower without the protective shield on the rear of the deck in place.

 **NOTE**

Under normal usage bag material is subject to wear and should be checked periodically. Be sure any replacement bag complies with the mower manufacturer's recommendations.

For replacement bags, use only factory authorized replacement bag.

# Models 464R thru 479R

4-10 LBS PRESSURE TO PULL BACK 15 LB MAX.

**ATTACHING THROTTLE WIRE TO LEVER**  
 Models 466R, 469R, 476R and 479R: Use upper hole in lever as shown. All Other Models: Use lower hole in lever.

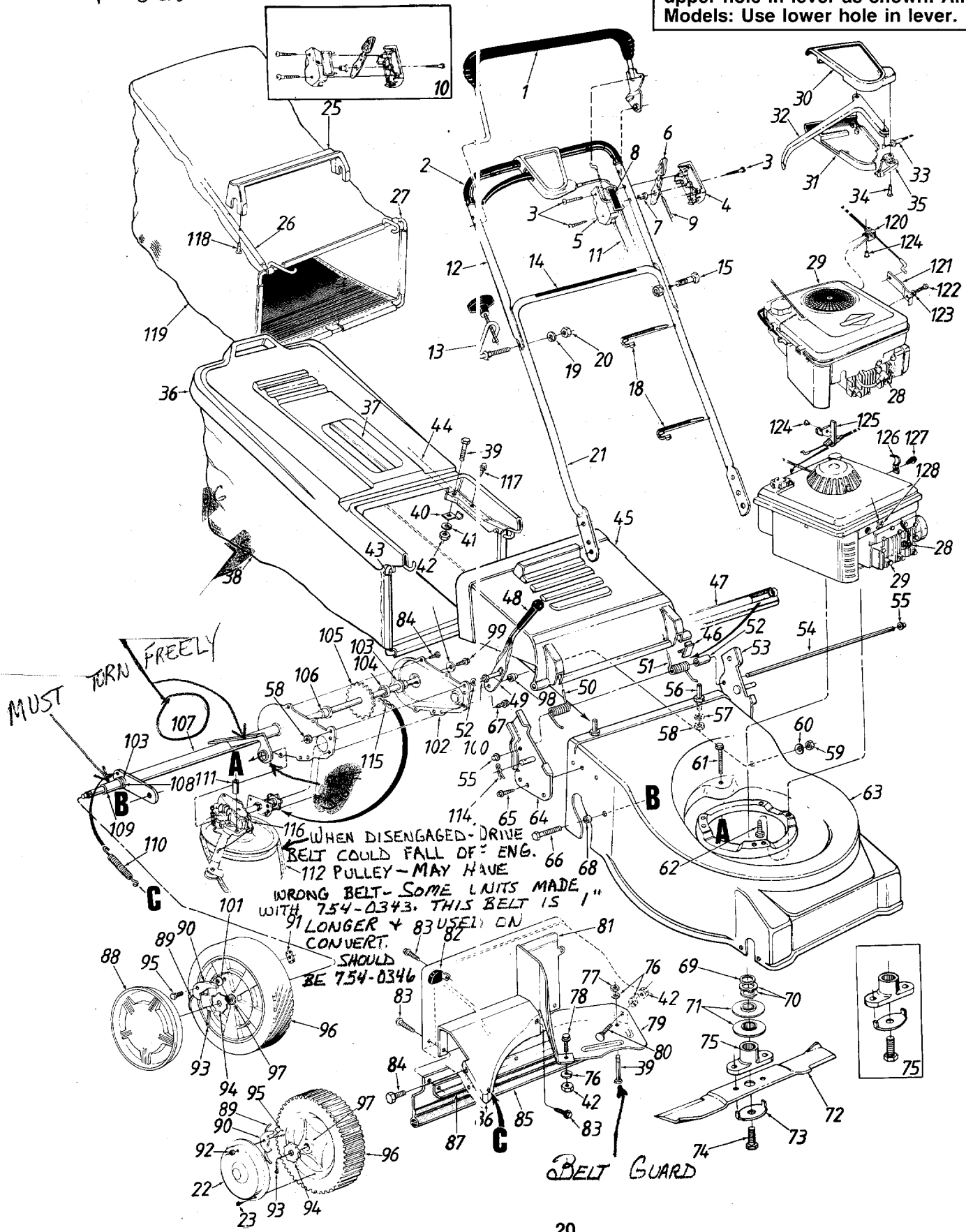

# Models 464R thru 479R

## PARTS LIST FOR MODELS 464R THRU 479R ROTARY MOWERS

REF. NO.	PART NO.	COLOR CODE	DESCRIPTION	NEW PART	REF. NO.	PART NO.	COLOR CODE	DESCRIPTION	NEW PART
1	731-0609		Control Handle Ass'y.		48	720-0223		Grip	
2	720-0225		Grip		49	732-0580		Spring Lever	
3	710-0796		Truss Mach. B-Tap Scr. #12 x 1.5" Lg.		50	732-0578		Torsion Spring—R.H.	N
					51	732-0577		Torsion Spring—L.H.	N
4	731-0817		Control Panel Half		52	750-0566		Spacer .255" I.D.	
5	731-0816		Clutch Panel Half		53	12297		Handle Brkt. Ass'y.—L.H.	
6	731-0528		Throttle Control Lever		54	747-0698		Hinge Pin 17.75" Lg.	
7	731-0524		Control Disc Pin		55	726-0106		Cap Speed Nut	
8	777-5774		Control Label—Throttle		56	711-0805		Shld. Pin 3/8-24 x 1.43" Lg.	
9	746-0632		Throttle Wire—53" Lg. (464R, 474R)		57	736-0169		L-Wash. 3/8" I.D.*	
	746-0640		Throttle Wire—45" Lg. (465R, 468R, 475R, 478R)		58	712-0711		Hex Jam Nut 3/8-24 Thd	
	746-0672		Throttle Wire—58" Lg. (466R, 469R, 476R, 479R)	N	59	712-0296		Hex L-Nut 3/8-24 Thd.	
10	753-0430		Control Housing Comp.		60	736-0105		Bell-Wash. .38" I.D. x .88"	
11	746-0480		Control Cable—46" Lg. (464R, 474R)		61	710-0778		Hex Wash. Hd. Tap Scr. 1/4-20 x 1.5" Lg.	
	746-0479		Control Cable—55" Lg. (465R, 468R, 475R, 478R)		62	710-0654		Hex L-Wash. Hd. Scr. 3/8-16 x 1" Lg.	
	746-0477		Control Cable—43" Lg. (466R, 469R, 476R, 479R)		63	16997	638	21" Deck Ass'y.	
12	749-0437		Upper Handle		64	12296		Handle Brkt. Ass'y.—R.H.	
13	710-0842		Rope Guide Bolt		65	710-0892		Hex L-Wash. Hd. AB-Tap Scr. 1/4 x .62" Lg.	
14	777-5776		Instruction Label—Handle		66	710-1006		Hex Wash. Hd. Tap Scr. 3/8-16 x .75" Lg.	
15	710-0671		Curved Carriage Bolt 5/16-18 x 1.38" Lg.		67	710-0599		Hex Wash. Hd. Tap Scr. 1/4-20 x .5" Lg.	
18	726-0240		Cable Tie		68	750-0526		Spacer .385" I.D.	
19	736-0119		L-Wash. 5/16" I.D.*		69	736-0409		Serrated Washer 1.0" I.D.	
20	712-0267		Hex Nut 5/16-18 Thd.*		70	736-0408		Wave Washer 1.005" I.D.	
21	749-0505		Lower Handle		71	756-0502		Serrated Pulley Half	
22	10647		Hub Cap		72	742-0306		21" Blade	
23	710-0748		Pan HD. Tap Scr. #12 x .50" Lg. (Used w/Ref. #22)		73	736-0415		Blade Bell-Wash. .44" I.D.	N
					74	710-0757		Hex Bolt 7/16-20 x 1.5" Lg. (Gr. 5)	
24	736-0270		Bell-Wash. .265" I.D. x .75"		75	753-0463		Blade Adapter Kit	N
25	731-0801		Bag Handle†		76	736-0329		L-Wash. 1/4" I.D.*	
26	749-0764		Rear Catcher Frame†	N	77	712-0298		Hex Jam Nut 1/4-20 Thd.	
27	747-0700		Front Catcher Frame†	N	78	710-0252		Hex Bolt 1/4-20 x .85" Lg.	
28	735-0639		Spark Plug Boot		79	17013		Rear Belt Baffle	N
29	—		Engine		80	710-0167		Carr. Bolt 1/4-20 x .50" Lg.*	
30	731-0617		Control Cover Half—Upper		81	17006		Rear Panel Baffle	N
31	731-0618		Control Cover Half—Lower		82	731-0931		Corner Plug	N
32	731-0620		Control Lever		83	710-1017		Torx Mach. AB-Tap Scr. 1/4 x .62" Lg.	N
33	746-0651		Drive Cable—53" Lg.		84	710-0352		Hex B-Tap Scr. 1/4 x .38" Lg.	
34	710-0841		Flat C-Sunk Hd. Tap Scr. #10 x .75" Lg.		85	731-0670		Rear Flap	
					86	17008		Rear Chute Baffle	N
35	731-0619		Cable Mtg. Cap		87	14847		Retaining Strip	N
36	731-0857		Hardtop Bag Cover††	N	88	731-0975		Hub Cap	
37	731-0856		Hardtop Handle††	N	89	10622		Plastic Spring	
38	764-0252	964	Grass Bag††	N	90	748-0188		Pawl .345" I.D.	
39	710-0166		Truss Mach. Scr. 1/4-20 x 1.0" Lg.††		91	712-0189		Weld Nut 1/4-20 Thd. (Used w/Ref. #88)	
40	12894		Mounting Clamp††		92	712-0324		Hex Ins. L-Nut 1/4-20 Thd. (Used w/Ref. #22)	
41	736-0463		Fl-Wash. .281" I.D. x .62"††		93	714-0115		Cotter Pin 1/8" Dia.	
42	712-0287		Hex Nut 1/4-20 Thd.*		94	748-0318		Ratchet Wheel 1.62" O.D.	
43	747-0693		Front Catcher Frame††	N	95	738-0137		Shld. Bolt .342" Dia. x .268"	
44	749-0736		Rear Catcher Frame††	N	96	**		Wheel Ass'y. Comp.—Rear	
45	731-0859		Chute Deflector	N	97	**		Flange Ball bearing 1/2" I.D.	
46	731-0970		Deflector Plug	N	98	750-0624		Shld. Spacer .50" Dia.	
47	731-0858		Seal—Extrusion	N					

# Models 464R thru 479R

## PARTS LIST FOR MODELS 464R THRU 479R ROTARY MOWERS (CONTINUED)

REF. NO.	PART NO.	COLOR CODE	DESCRIPTION	NEW PART	REF. NO.	PART NO.	COLOR CODE	DESCRIPTION	NEW PART
99	710-0751		Hex Bolt 1/4-20 x .62" Lg. (Gr. 5)		117	710-0776		Hex AB-Tap Scr. 1/4 x .62" Lg.††	
100	711-0805		Shld. Pin 3/8-24 x 1.43" Lg.		118	710-1025		Hex AB-Tap Scr. #12 x 1.25" Lg.†	N
101	736-0270		Bell-Wash. .265" I.D. x .75" (Used w/Ref. #88)		119	764-0246		Grass Bag†	N
102	17053		Chain Cover Ass'y.		120	16703		Cable Mtg. Brkt. (464R, 474R)	N
103	741-0324		Hex Flange Brg. .506" I.D.		121	16704		Mounting Brkt. (464R, 474R)	N
104	736-0160		FI-Wash. .531" I.D. x .93"		122	710-0473		Truss Mach. Scr. #10 x .5" Lg. (464R, 474R)	
105	738-0719		Rear Axle Ass'y.		123	736-0722		L-Wash. #10 I.D. (464R, 474R)	
106	741-0522		Hex Flange Bearing		124	728-0171		Pop Rivet .156" Dia. (B&S)	
107	17009		Chain Axle Ass'y.	N	125	14924		Cable Brkt. (466R, 469R, 476R, 479R)	
108	736-0326		FI-Wash. .510" I.D. x 1.0"		126	12894		Cable Clamp (466R, 469R, 476R, 479R)	
109	748-0190		Spacer .513" I.D.		127	710-0429		Hex B-Tap Scr. #10 x .38" Lg. (466R, 469R, 476R, 479R)	
110	732-0481		Extension Spring 3.8" Lg.		128	710-0436		Hex B-Tap Scr. #10 x .62" Lg. (466R, 469R, 476R, 479R)	
111	750-0589		Spacer .325" I.D.		129	751-0463		Cable Clamp (466R, 469R, 476R, 479R)	
112	754-0346		V-Belt 3/8 X 30.2"						
114	714-0104		Internal Cotter Pin 5/16" Dia.						
115	713-0353		#48 Chain .50" Pitch x 3C Links						
116	717-0417		Transmission Comp. (See Breakdown)						

†Models 464R thru 469R Only.  
††Models 474R thru 479R Only.

NOTE: The engine is not under warranty by the mower manufacturer... If repairs or service is needed on the engine, please contact your nearest authorized engine service outlet. Check the "Yellow Pages" of your telephone book under "Engines—Gasoline."

Find It Fast  
In The  
Yellow Pages

➔ NOTE

This instruction manual covers various models, and all specifications shown do not necessarily apply to your model. Specifications subject to change without notice or obligation.

### \*\* REAR WHEEL CHART

STEEL —  
STEEL —  
PLASTIC —

Size	Tread Type	Part No.	Bearings
8 x 1.5	"T" Tread	734-1412	741-0180 1/2" I.D. Ball Brg. (2 Req'd.)
8 x 1.75	"T" Tread	734-1260	741-0180 1/2" I.D. Ball Brg. (FRONT) (2 Req'd.)
8 x 2	"S" Wave	734-1510	741-0486 1/2" I.D. Sleeve Brg.

# Models 464R thru 479R

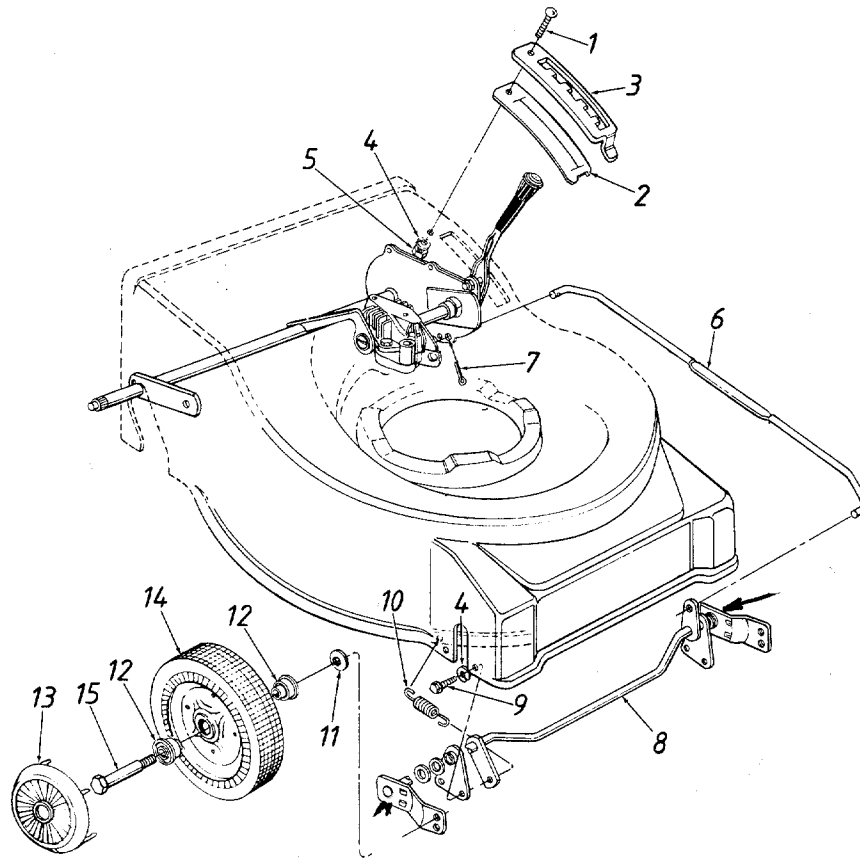

## PARTS LIST FOR MODELS 464R THRU 479R ROTARY MOWERS

REF. NO.	PART NO.	COLOR CODE	DESCRIPTION	NEW PART	REF. NO.	PART NO.	COLOR CODE	DESCRIPTION	NEW PART
1	710-0946		Truss Mach. Scr. 1/4-20 x .62" Lg.*		9	710-0352		Hex L-Wash. Hd. AB-Tap Scr. 1/4 x .38" Lg.	
2	721-0216		Height Adjustment Support	N	10	732-0589		Extension Spring 2.39" Lg.	
3	17323		Height Adjustment Plate		11	736-0105		Bell-Wash. .380" I.D. x .88" O.D.	
4	736-0329		L-Wash. 1/4" I.D.*		12	741-0180		Flange Ball Bearing 1/2" I.D.	
5	712-0287		Hex Nut 1/4-20 Thd.*		13	—		Hub Cap (See Below)	
6	747-0699		Height Adj. Connecting Rod		14	**		Wheel Ass'y. Comp.—Front	
7	714-0507		Cotter Pin 3/32" Dia.		15	738-0102		Shld. Bolt .498" Dia. x 1.45"	
8	17022-6637		Front Axle Ass'y.						

\*For faster service obtain standard nuts, bolts and washers locally. If these items cannot be obtained locally, order by part number and size as shown on parts list.

### \*\*FRONT WHEEL CHART

Size	Tread Type	Part No.
7 x 1.75	"T" Tread	734-1264
8 x 1.5	"T" Tread	734-1412
8 x 1.75	"T" Tread	734-1260
8 x 2	"S" Wave	734-1513 (Use 731-0975 Hub Cap)

### Optional Hub Caps

Color	Part No.
Red	731-0124
Orange	731-0284
Black	731-0364
Grey	731-0386

# Models 464R thru 479R

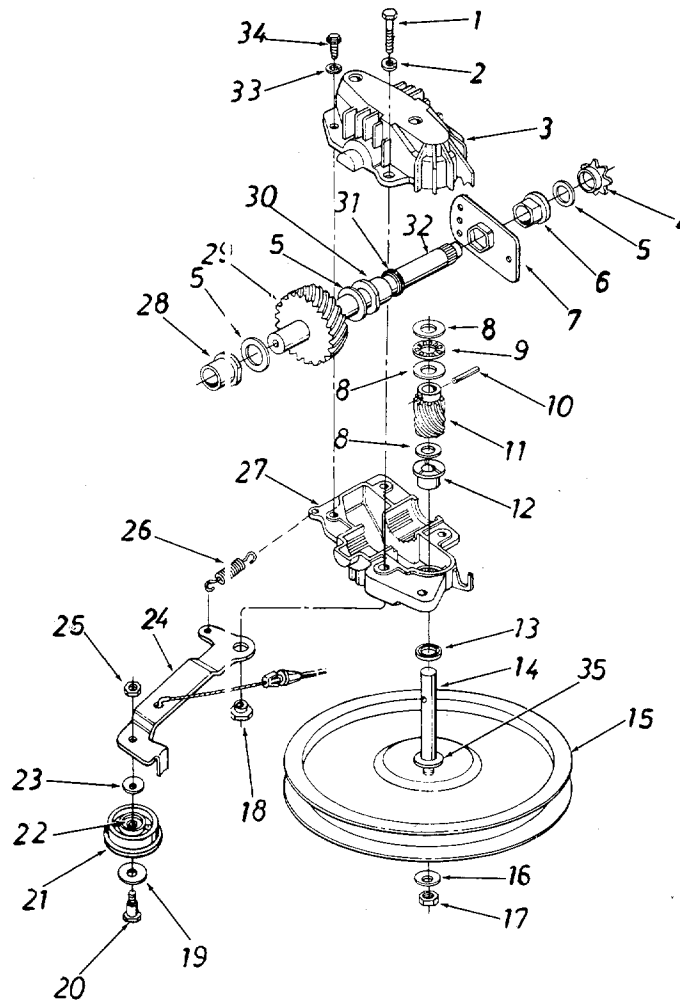

**PARTS LIST FOR MODELS 464R THRU 479R ROTARY MOWERS**

REF. NO.	PART NO.	COLOR CODE	DESCRIPTION	NEW PART	REF. NO.	PART NO.	COLOR CODE	DESCRIPTION	NEW PART
1	710-0106		Hex Bolt 1/4-20 x 1.25" Lg.		18	738-0440		Shld. Spacer .375" Dia. x .170"	
2	736-0329		L-Wash. 1/4" I.D.*		19	736-0344		Fl-Wash. .390" I.D. x 1.0"†	
3	717-0418		Upper Hsg. Half		20	738-0691		Shld. Bolt .375" Dia. x .40"†	
4	713-0400		#48 Sprocket 7 Tooth x 1/2 Pitch		21	756-0447		Fl-Idler Plastic 1.50" Dia.†	
5	736-0336		Fl-Wash. 5/8" I.D. x .030		22	741-0482		Needle Brg. .375" x .31†	
6	741-0413		Hex Flange Brg. .631" I.D.		23	736-0270		Bell-Wash. .265" I.D. x .75"†	
7	16500		Hex Bearing Cup		24	17052		Idler Brk't. Ass'y.†	
8	736-0314		Thrust Wash. .382" I.D. x .70" O.D.		25	712-0138		Hex Patch L-Nut 1/4-28 Thd.†	
9	741-0479		Thrust Bearing .375" I.D. x .812" O.D.		26	732-0357		Extension Spring 1.12" Lg.†	
10	715-0152		Spring Pin Spir. 1/8" x .62" Heavy		27	717-0419		Lower Hsg. Half	
11	717-0420		11 Tooth Helical Gear		28	741-0415		Flange Bearing .566 Dia.	
12	748-0208		Flange Bearing		29	717-0422		33 Tooth Helical Gear	
13	721-0212		Oil Seal		30	741-0414		Flange Bearing .629 Dia.	
14	738-0708		Pulley-Transmission Shaft		31	721-0213		Oil Seal .625 Dia.	
15	756-0330		Fl-Pulley 5.06" O.D.†		32	738-0607		Gear Sprocket Shaft	
16	736-0270		Bell-Wash. .265" I.D. x .75"†		33	736-0722		L-Wash. #10 I.D.	
17	712-0351		Hex L-Nut 1/4-28 L.H. Thd.†		34	710-0436		Hex B-Tap Scr. #10 x .62"	
					35	736-0410		Hex Washer .26" x .88"†	
					—	717-0417		Transmission Comp.	

†Not Part of Transmission Complete



# Trouble Shooting Chart

Symptom	Possible Causes	Corrective Action
1 Engine fails to start	<p><b>A</b> Blade control handle disengaged</p> <p><b>B</b> Check fuel tank for fuel</p> <p><b>C</b> Fuel shut-off valve closed (on units so equipped).</p> <p><b>D</b> Spark plug lead wire disconnected.</p> <p><b>E</b> Throttle control lever not in the starting position</p> <p><b>F</b> Faulty spark plug</p> <p><b>G</b> Carburetor improperly adjusted, engine flooded</p> <p><b>H</b> Old stale fuel</p> <p><b>I</b> Engine brake engaged</p>	<p><b>A</b> Engage blade control handle.</p> <p><b>B</b> Fill tank if empty.</p> <p><b>C</b> Open fuel shut-off valve.</p> <p><b>D</b> Connect lead wire.</p> <p><b>E</b> Move throttle lever to start position.</p> <p><b>F</b> Clean, adjust gap or replace.†</p> <p><b>G</b> Remove spark plug, dry the plug, crank engine with plug removed, and throttle in off position. Replace spark plug and lead wire and resume starting procedures.</p> <p><b>H</b> Drain and refill with fresh fuel.</p> <p><b>I</b> Follow starting procedure.</p>
2 Hard starting or loss of power	<p><b>A</b> Spark plug wire loose</p> <p><b>B</b> Carburetor improperly adjusted</p> <p><b>C</b> Dirty air cleaner</p>	<p><b>A</b> Connect and tighten spark plug wire.</p> <p><b>B</b> Adjust carburetor.†</p> <p><b>C</b> Clean air cleaner.†</p>
3 Operation erratic	<p><b>A</b> Dirt in fuel tank</p> <p><b>B</b> Dirty air cleaner</p> <p><b>C</b> Water in fuel supply</p> <p><b>D</b> Vent in gas cap plugged</p> <p><b>E</b> Carburetor improperly adjusted</p>	<p><b>A</b> Remove the dirt and fill tank with fresh fuel.</p> <p><b>B</b> Clean air cleaner.†</p> <p><b>C</b> Drain contaminated fuel and fill tank with fresh fuel.</p> <p><b>D</b> Clear vent or replace gas cap.</p> <p><b>E</b> Adjust carburetor.†</p>
4 Occasional skip (hesitates) at high speed	<p><b>A</b> Carburetor idle speed too slow</p> <p><b>B</b> Spark plug gap too close</p> <p><b>C</b> Carburetor idle mixture adjustment improperly set</p>	<p><b>A</b> Adjust carburetor.†</p> <p><b>B</b> Adjust to .030".</p> <p><b>C</b> Adjust carburetor.†</p>
5 Idles poorly	<p><b>A</b> Spark plug fouled, faulty, or gap too wide</p> <p><b>B</b> Carburetor improperly adjusted</p> <p><b>C</b> Dirty air cleaner</p>	<p><b>A</b> Reset gap to .030" or replace spark plug.</p> <p><b>B</b> Adjust carburetor.†</p> <p><b>C</b> Clean air cleaner.†</p>
6 Engine overheats	<p><b>A</b> Carburetor not adjusted properly</p> <p><b>B</b> Air flow restricted</p> <p><b>C</b> Engine oil level low</p>	<p><b>A</b> Adjust carburetor.†</p> <p><b>B</b> Remove blower housing and clean.†</p> <p><b>C</b> Fill crankcase with the proper oil or fuel mixture.</p>
7 Excessive vibration	<p><b>A</b> Cutting blade loose or unbalanced</p> <p><b>B</b> Bent cutting blade</p>	<p><b>A</b> Tighten blade and adapter. Balance blade.</p> <p><b>B</b> Replace blade.</p>

†Refer to separate engine manual packed with your unit.

**Note:** For repairs beyond the minor adjustments listed above, contact your local authorized service dealer.

# PARTS INFORMATION

## POWER EQUIPMENT PARTS AND SERVICE

Parts and service are available through the authorized service firms listed below. All orders should specify the model number of your unit, part numbers, description of parts and the quantity of each part required.

## BRIGGS AND STRATTON, TECUMSEH AND PEERLESS PARTS AND SERVICE

Briggs & Stratton, Tecumseh and Peerless parts and service should be handled by your nearest authorized engine service firm. Check the yellow pages of your telephone directory under the listing **Engines—Gasoline**, Briggs & Stratton or Tecumseh Lauson.

**NOTE:** If any parts are found to be missing or defective upon assembly of this unit, write to advise the factory so that immediate replacement can be made.

<b>ALABAMA</b>	<b>BIRMINGHAM</b>	<b>NEW YORK</b>	<b>CARTHAGE</b>
Auto Electric & Carburetor Co. . . . .	2625 4th Ave. S. . . . . 35233	Gamble Dist., Inc. . . . .	West End Ave. . . . . 13619
<b>ARKANSAS</b>	<b>NORTH LITTLE ROCK</b>	<b>NORTH CAROLINA</b>	<b>GREENSBORO</b>
Sutton's Lawn Mower Shop . . . . .	5301 Roundtop Drive	Dixie Sales Company . . . . .	335 N. Green . . . . . 27402
	Box 368, Rt. 4 . . . . . 72117	<b>OHIO</b>	<b>CARROLL</b>
<b>CALIFORNIA</b>	<b>PORTERVILLE</b>	Stebe's Mid-State Mower Supply	Box 366, 71 High St. . . . . 43112
Billious . . . . .	75 North D Street . . . . . 93257		<b>CLEVELAND</b>
<b>COLORADO</b>	<b>DENVER</b>	Bleckrie, Inc. . . . .	7900 Lorain Ave. . . . . 44102
Spitzer Industrial Products Co. . . . .	6601 N.	National Central . . . . .	<b>WADSWORTH</b>
	Washington St. . . . . 80229	Burton Supply Co. . . . .	687 Seville Rd. . . . . 44281
<b>FLORIDA</b>	<b>JACKSONVILLE</b>		<b>YOUNGSTOWN</b>
Radco Distributors . . . . .	4909 Victor St.		1301 Logan Ave.
	Box 5459 . . . . . 32207		Box 929 . . . . . 44501
	<b>HIALEAH</b>	<b>PENNSYLVANIA</b>	<b>HARRISBURG</b>
Small Eng. Dist. . . . .	7995 W. 26th Court . . . . . 33016	EECO Inc. . . . .	4021 N. 6th St. . . . . 17110
<b>GEORGIA</b>	<b>EAST POINT</b>		<b>WILLOW GROVE</b>
East Point Cycle & Key Inc. . . . .	2834 Church St. . . . . 30344	Thompson Rubber Co. . . . .	850 Davisville Rd. . . . . 19090
<b>ILLINOIS</b>	<b>LYONS</b>	Bluemont Co. . . . .	<b>PITTSBURGH</b>
Keen Edge Co. . . . .	8615 Ogden Ave. . . . . 60534	Frank Roberts & Sons . . . . .	11101 Frankstown Rd. . . . . 15235
<b>INDIANA</b>	<b>ELKHART</b>		<b>PUNXSUTAWNEY</b>
Parts & Sales Inc. . . . .	2101 Industrial Pkwy. . . . . 46516		R.D. 2 . . . . . 15767
<b>IOWA</b>	<b>DUBUQUE</b>		<b>SCRANTON</b>
Power Lawn & Garden Equip. . . . .	2551 J.F. Kennedy . . . . . 52001	Scranton Auto Ignition Co. . . . .	1133-35 Wyoming Ave. . . . . 18509
<b>LOUISIANA</b>	<b>NEW ORLEANS</b>	<b>TENNESSEE</b>	<b>KNOXVILLE</b>
Suhren Engine Co. . . . .	8330 Earhart Blvd. . . . . 70118	Ace Distributors . . . . .	2103 Magnolia . . . . . 37917
<b>MARYLAND</b>	<b>TAKOMA PARK</b>		<b>MEMPHIS</b>
Center Supply Co. . . . .	6867 New Hampshire	American Sales & Service, Inc. . . . .	3035-43 Bellbrook . . . . . 38116
	Ave. . . . . 20912	<b>TEXAS</b>	<b>DALLAS</b>
<b>MASSACHUSETTS</b>	<b>SPRINGFIELD</b>	Marr Brothers, Inc. . . . .	423 E. Jefferson . . . . . 75203
Morton B. Collins Co. . . . .	300 Birnie Ave. . . . . 01107	Engine House Inc. . . . .	<b>SAN ANTONIO</b>
<b>MICHIGAN</b>	<b>MOUNT CLEMENS</b>		8610 Botts Lane
Power Equipment Dist. . . . .	340 Hubbard . . . . . 48043		P.O. Box 17867 . . . . . 78217
<b>MINNESOTA</b>	<b>PLYMOUTH</b>	<b>UTAH</b>	<b>SALT LAKE CITY</b>
Hance Distributing Inc. . . . .	12795 16th Ave. North . . . . . 55441	Powered Products . . . . .	1661 N. Beck St. . . . . 84116
<b>MISSOURI</b>	<b>EARTH CITY</b>	<b>VIRGINIA</b>	<b>ASHLAND</b>
Oscar Wilson Engine & Parts . . . . .	4159 Shoreline Dr. . . . . 63045	RBI Corp. . . . .	101 Cedar Ridge Dr. . . . . 23005
	<b>KANSAS CITY</b>	<b>WASHINGTON</b>	<b>SEATTLE</b>
Automotive Equip. Service . . . . .	3117 Holmes St. . . . . 64109	Equip. Northwest . . . . .	1410 14th Ave. . . . . 98122
<b>NEW JERSEY</b>	<b>ALLOWAY</b>	<b>WISCONSIN</b>	<b>MILWAUKEE</b>
Piersons . . . . .	Canal St., Box 494 . . . . . 08001	Wisconsin Magneto Inc. . . . .	4727 N. Teutonia St. . . . . 53209
<b>NEW MEXICO</b>	<b>ALBUQUERQUE</b>		
Spitzer Eng. & Parts Co. . . . .	1023 Third Ave. N.W. . . . . 87103		

### WARRANTY PARTS AND SERVICE POLICY

(0687)

The purpose of warranty is to protect the customer from defects in workmanship and materials, defects which are NOT detected at the time of manufacture. It does not provide for the unlimited and unrestricted replacement of parts. Use and maintenance are the responsibility of the customer. The manufacturer cannot assume responsibility for conditions over which it has no control. Simply put, if it's the manufacturer's fault, it's the manufacturer's responsibility; if it's the customer's fault, it's the customer's responsibility.

#### CLAIMS AGAINST THE MANUFACTURER'S WARRANTY INCLUDES:

1. Replacement of Missing Parts on new equipment.
2. Replacement of Defective Parts within the warranty period.
3. Repair of Defects within the warranty period.

All claims MUST be substantiated with the following information:

1. Model Number, Serial Number and/or Data Code of unit involved.
2. Date unit was purchased or first put into service.
3. Date of Failure.
4. Nature of Failure.