

\$1.00

OWNER'S GUIDE

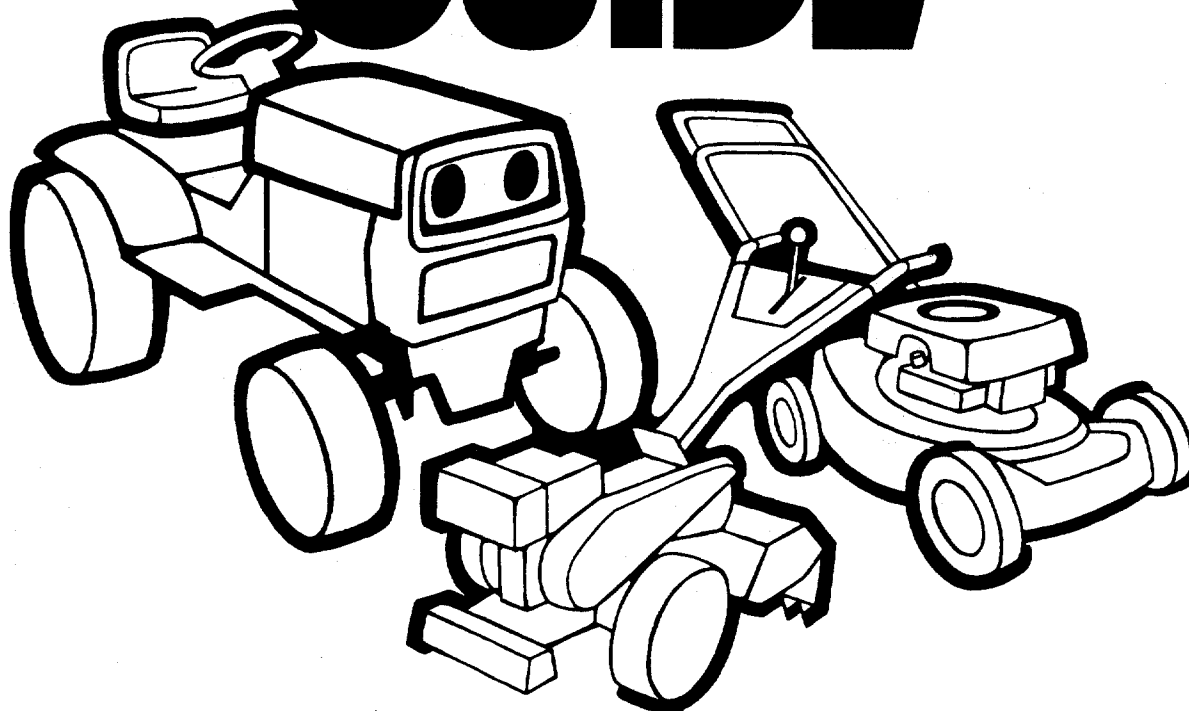

**22" SELF-
PROPELLED
ROTARY
MOWER**

**Model Numbers
127-280-000
127-282-000**

IMPORTANT: Read Safety Rules and Instructions Carefully

INDEX

Slope Gauge	3
Contents of Hardware Pack	4
Rules for Safe Operation	5
Assembly	6
Controls	10
Operation	11
Adjustments	12
Lubrication	14
Maintenance	14
Off-Season Storage	15
Illustrated Parts	16
Repair Parts List	17, 18
Trouble Shooting Chart	19
Parts Information	Back Cover

Dear Customer,

So often throughout the year we are all in a rush to meet our daily obligations.

However, we at MTD Products Inc are taking a quick moment out to say...

"Thank you for your business."

Sincerely,
MTD PRODUCTS INC



INSTRUCTIONS GIVEN WITH THIS SYMBOL ARE FOR PERSONAL SAFETY. BE SURE TO FOLLOW THEM.

LIMITED WARRANTY

For one year from the date of original retail purchase, MTD PRODUCTS INC will either repair or replace, at its option, free of charge, F.O.B. factory or authorized service firm, any part or parts found to be defective in material or workmanship. Transportation charges for the movement of any power equipment unit or attachment are the responsibility of the purchaser. Transportation charges for any parts submitted for replacement under this warranty must be paid by the purchaser unless such return is requested by MTD PRODUCTS INC.

This warranty will not apply to any part which has become inoperative due to misuse, excessive use, accident, neglect, improper maintenance, alterations, or unless the unit has been operated and maintained in accordance with the instructions furnished. This warranty does not apply to the engine, motor, battery, battery charger or component parts thereof. Please refer to the applicable manufacturer's warranty on these items.

This warranty will not apply where the unit has been used commercially.

Warranty service is available through your local authorized service dealer or distributor. If you do not know the dealer or distributor in your area, please write to the Customer Service Department of MTD.

The return of a complete unit will not be accepted by the factory unless prior written permission has been extended by MTD.

This warranty gives you specific legal rights. You may also have other rights which vary from state to state.

WARNING: This unit is equipped with an internal combustion engine and should not be used on or near any unimproved forest-covered, brush-covered or grass-covered land unless the engine's exhaust system is equipped with a spark arrester meeting applicable local or state laws (if any). If a spark arrester is used, it should be maintained in effective working order by the operator.

In the State of California the above is required by law (Section 4442 of the California Public Resources Code). Other states may have similar laws. Federal laws apply on federal lands. A spark arrester muffler is available at your nearest engine authorized service center.

Cut Along This Line

USE THIS SHEET AS A GUIDE TO DETERMINE SLOPES WHERE YOU MAY NOT OPERATE SAFELY.

SLOPE GAUGE

(Keep this sheet in a safe place for future reference.)

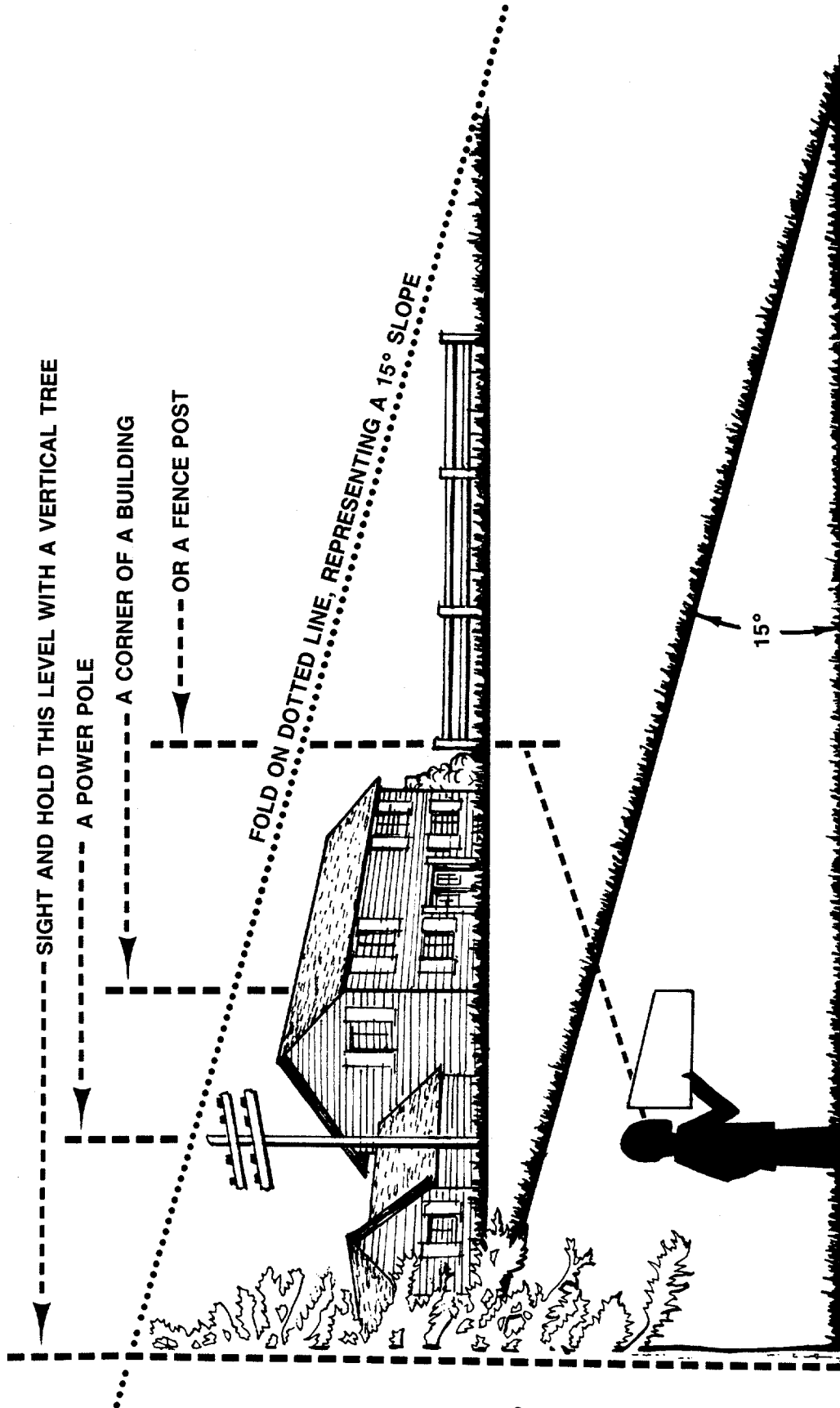

Do not mow on inclines with a slope in excess of 15 degrees (a rise of approximately 2½ feet every 10 feet). A riding mower could overturn and cause serious injury. If operating a walk-behind mower on such a slope, it is extremely difficult to maintain your footing and you could slip, resulting in serious injury.

Operate RIDING mowers up and down slopes, never across the face of slopes.

Operate WALK-BEHIND mowers across the face of slopes, never up and down slopes.

CONTENTS OF HARDWARE PACK/PARTS IDENTIFICATION

Remove this sheet from your owner's manual and lay the hardware on the illustration for identification purposes. After assembly, keep the Slope Gauge which is on the reverse side of this sheet for future use.

(Hardware pack may contain extra items which are not used on your unit.)

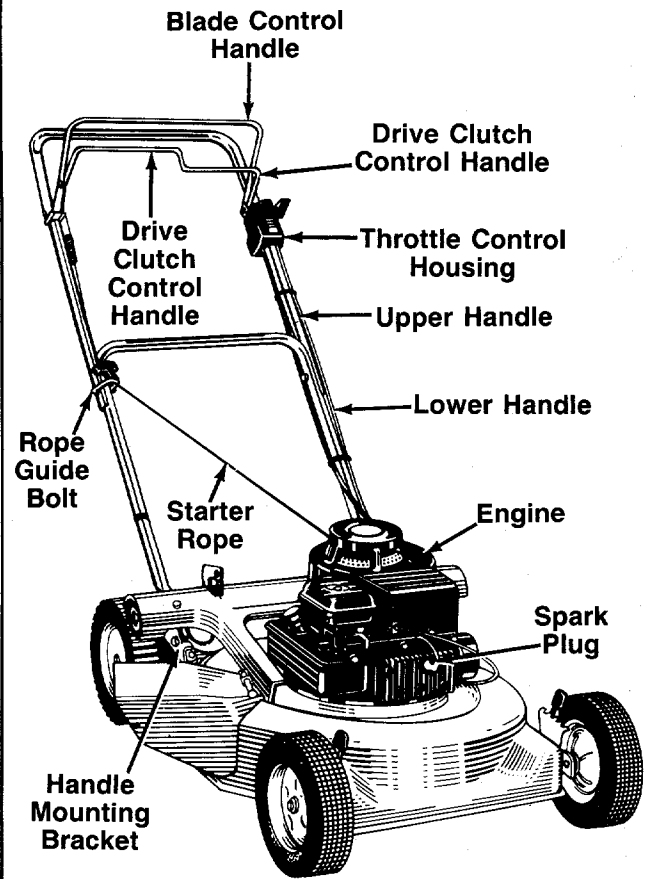
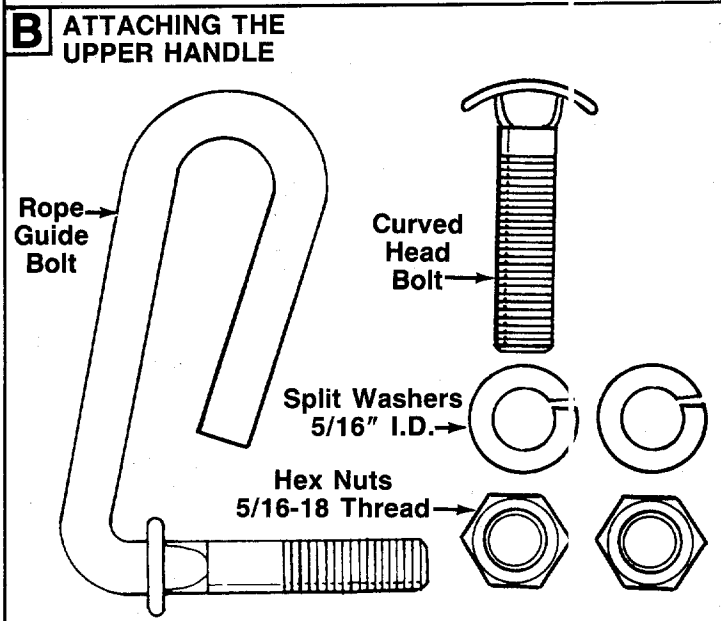
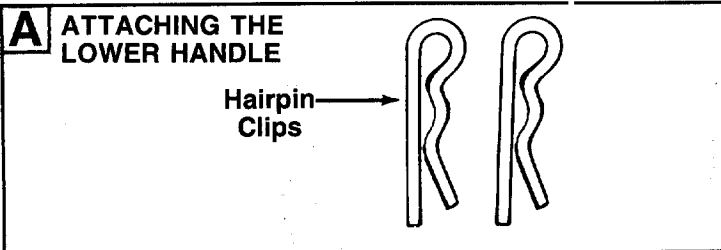

PARTS IDENTIFICATION

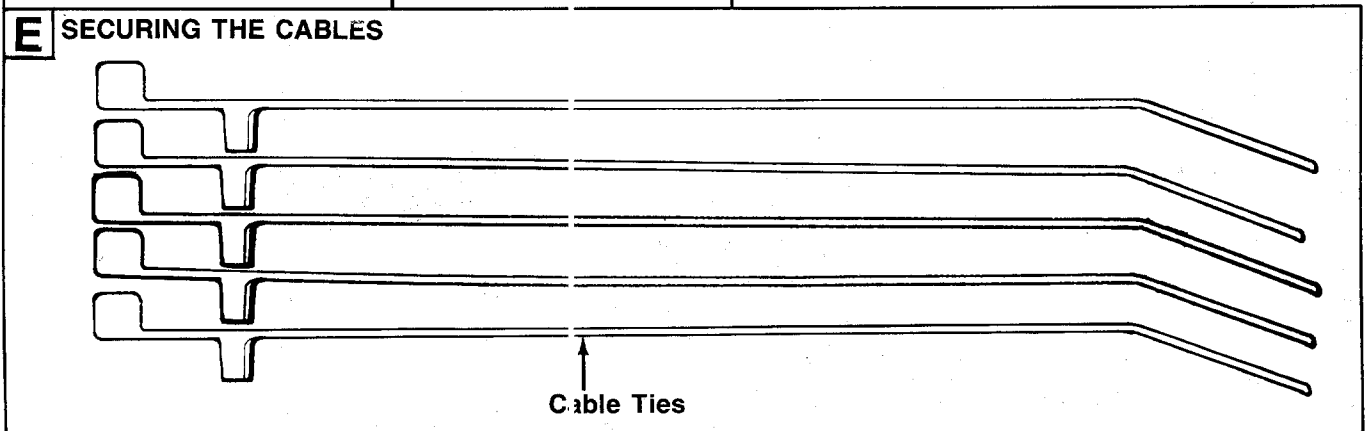
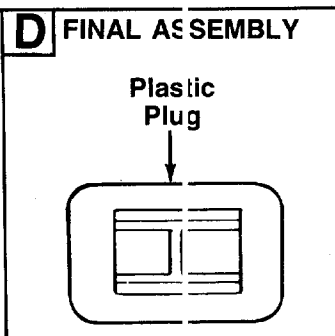
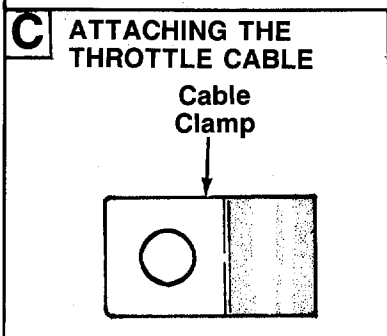

Cut Along this Line

IMPORTANT

RULES FOR SAFE OPERATION



THIS SYMBOL POINTS OUT IMPORTANT SAFETY INSTRUCTIONS WHICH, IF NOT FOLLOWED, COULD ENDANGER THE PERSONAL SAFETY AND/OR PROPERTY OF YOURSELF AND OTHERS. READ AND FOLLOW ALL INSTRUCTIONS IN THIS MANUAL BEFORE ATTEMPTING TO OPERATE YOUR LAWN MOWER. FAILURE TO COMPLY WITH THESE INSTRUCTIONS MAY RESULT IN PERSONAL INJURY. WHEN YOU SEE THIS SYMBOL—  **HEED ITS WARNING.**



DANGER

Your lawn mower was built to be operated according to the rules for safe operation in this manual. As with any type of power equipment, carelessness or error on the part of the operator can result in serious injury. If you violate any of these rules, you may cause serious injury to yourself or others.



TRAINING

1. Read this owner's manual carefully in its entirety before attempting to assemble or operate this machine. Be completely familiar with the controls and the proper use of this machine before operating it. Keep this manual in a safe place for future and regular reference and for ordering replacement parts.
2. Your rotary mower is a precision piece of power equipment, not a plaything. Therefore, exercise extreme caution at all times.
3. Never allow children to operate a power mower. Only persons well acquainted with these rules of safe operation should be allowed to use your mower.
4. Keep the area of operation clear of all persons, particularly small children and pets. Stop engine when they are in the vicinity of your mower to help prevent blade contact or thrown object injury. Although the area of operation should be completely cleared of foreign objects, an object may have been overlooked and could be accidentally thrown by the mower in any direction and cause serious personal injury to the operator or any others allowed in the area.



PREPARATION

1. Thoroughly inspect the area where the equipment is to be used. Remove all stones, sticks, wire, bones and other foreign objects which could be picked up and thrown by the mower in any direction and cause serious personal injury to the operator or any others allowed in the area.
2. Always wear safety glasses or eye shields during operation or while performing an adjustment or repair, to protect eyes from foreign objects that may be thrown from the machine in any direction.
3. Wear sturdy, rough-soled work shoes and close-fitting slacks and shirts to avoid entanglement in the moving parts. Never operate a unit in bare feet, sandals, or sneakers.
4. Check the fuel before starting the engine. Gasoline is an extremely flammable fuel. Do not fill the gasoline tank indoors, while the engine is running, or until engine has been allowed to cool for two minutes after running. Replace gasoline cap securely and wipe off any spilled gasoline before starting the engine as it may cause a fire or explosion.
5. Disengage the self-propelled mechanism or drive clutch on units so equipped before starting the engine.
6. The blade control handle is a safety device. Never attempt to bypass its operation. Doing so makes the safety device inoperative and may result in personal injury through contact with the rotating blade. The blade control handle must operate easily in both directions.
7. Never attempt to make a wheel or cutting height adjustment while the engine is running.
8. Never operate the equipment in wet grass. Always be sure of your footing. A slip and fall can cause serious personal injury. Keep a firm hold on the handle and walk, never run. Mow only in daylight or in good artificial light.

9. For your safety, use the slope gauge included as part of this manual to measure slopes before operating this unit on a sloped or hilly area. If the slope is greater than 15° as shown on the slope gauge, do not operate this unit on that area or serious injury could result.



OPERATION

1. Do not change the engine governor settings or overspeed the engine. Excessive engine speeds are dangerous.
2. Do not put hands or feet near or under rotating parts. Keep clear of the discharge opening at all times as the rotating blade can cause injury.
3. Stop the blade when crossing gravel drives, walks or roads.
4. After striking a foreign object, stop the engine, remove the wire from the spark plug, and thoroughly inspect the mower for any damage. Repair the damage before restarting and operating the mower.
5. If the equipment should start to vibrate abnormally, stop the engine and check immediately for the cause. Vibration is generally a warning of trouble.
6. Shut the engine off and wait until the blade comes to a complete stop before removing the grass catcher or unclogging the chute. The cutting blade continues to rotate for a few seconds after the engine is shut off. Never place any part of the body in the blade area until you are sure the blade has stopped rotating.
7. Before cleaning, repairing or inspecting, make certain the blade and all moving parts have stopped. Disconnect the spark plug wire, and keep the wire away from the spark plug to prevent accidental starting.
8. Do not run the engine indoors.
9. Mow across the face of slopes, never up-and-down. Exercise extreme caution when changing direction on slopes. Do not mow excessively steep slopes. Always be sure of your footing. A slip and fall can cause serious personal injury.
10. Never operate mower without proper guards, plates or other safety protective devices in place.



MAINTENANCE AND STORAGE

1. Check the blade and engine mounting bolts at frequent intervals for proper tightness.
2. Keep all nuts, bolts, and screws tight to be sure the equipment is in safe working condition.
3. Never store the equipment with gasoline in the tank inside of a building where fumes may reach an open flame or spark. Allow the engine to cool before storing in any enclosure.
4. To reduce fire hazard, keep the engine free of grass, leaves, or excessive grease.
5. Check the grass catcher bag frequently for wear or deterioration. For safety protection, replace only with new bag meeting original equipment specifications.

IMPORTANT: This unit is shipped WITHOUT GASOLINE or OIL. After assembly, service engine with gasoline and oil as instructed in the separate engine manual packed with your unit.

NOTE: Reference to right or left hand side of the mower is observed from the operating position. Refer to parts identification on page 4 for location of parts when assembling the mower.

ASSEMBLY INSTRUCTIONS

Tools Required for Assembly

- (1) Phillips Head Screwdriver
- (1) 1/2" Wrench*
- (1) 5/16" Wrench or Nutdriver*
- (1) 7/16" Wrench*
- *Or one 6" Adjustable Wrench.

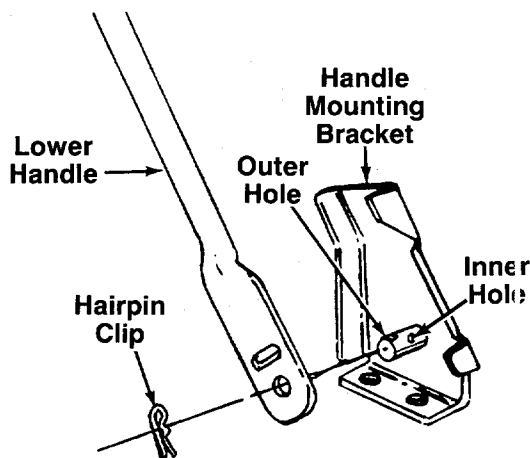

FIGURE 1.

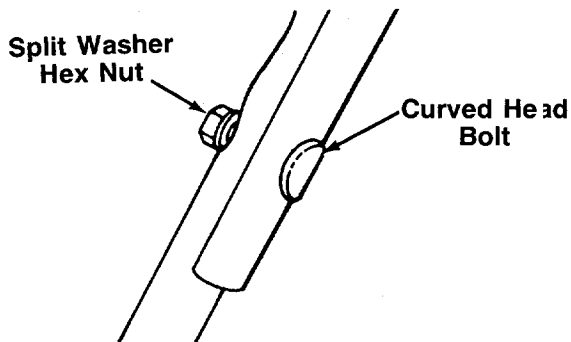

FIGURE 2.

UNPACKING

1. Remove the lawn mower from the carton by opening the top flaps and lifting the unit out. Be careful of the staples. Make certain all parts and literature have been removed from the carton before the carton is discarded.
2. Disconnect and ground the spark plug wire against the engine. Check beneath the deck for any cardboard packaging. Remove if present.
3. Stretch out all control cables and place on the floor. Be careful not to bend or kink the cables at any time during assembly.
4. Remove page four from this manual and lay the contents of the hardware pack on the illustration for identification.

ATTACHING THE LOWER HANDLE (Hardware A)

Attach the lower handle by placing the bottom holes in the lower handle over the weld pins on the handle mounting brackets on the rear of the deck. Make certain the instruction label on the lower handle can be read from the operating position. Secure with hairpin clips in inner holes on weld pins. See figure 1.

NOTE

There are two (2) holes in the handle mounting brackets. Place the hairpin clip in the inner hole for operation. Outer hole is for storage.

It may be necessary to bend the ends of the lower handle outward slightly to obtain a tight fit against the handle mounting brackets.

ATTACHING THE UPPER HANDLE (Hardware B)

1. Place the upper handle in position over the lower handle. The label on the throttle control housing and the control lever must be facing up.

NOTE

The right hand side of the handle will be secured with the rope guide bolt. However, left handed operators may assemble the rope guide bolt to the left side of the handle for easier starting by following steps 2 and 3 and reversing the left and right hand instructions.

2. Secure the left hand side of upper handle using the curved head bolt, split washer and hex nut as shown in figure 2.

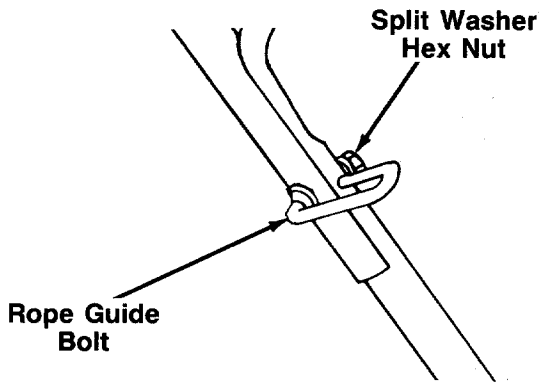

FIGURE 3.

3. Insert the rope guide bolt through the right hand side of upper and lower handle. See figure 3. Secure with split washer and hex nut, finger tight only.

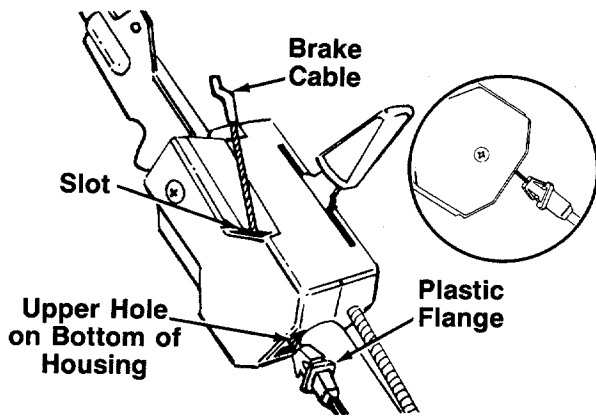

FIGURE 4.

ATTACHING THE BRAKE CABLE

1. The brake cable is attached to the engine, and has a "Z" fitting on the loose end. Route the brake cable below the lower handle. Place end of cable into the upper hole on the bottom of the control housing, and through the slot as shown. The angle of the plastic flange must be positioned downward as shown in figure 4. Be careful not to bend or kink the cable at any time.
2. Push the plastic fitting until it locks into the control housing.



Brake cable must be assembled as shown for proper blade brake operation.

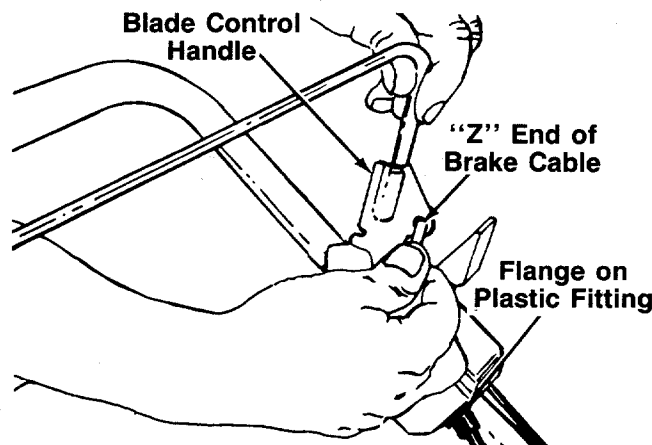

FIGURE 5.

3. Hook the "Z" end of the brake cable into the hole in the blade control handle from the inside to the outside as shown in figure 5.

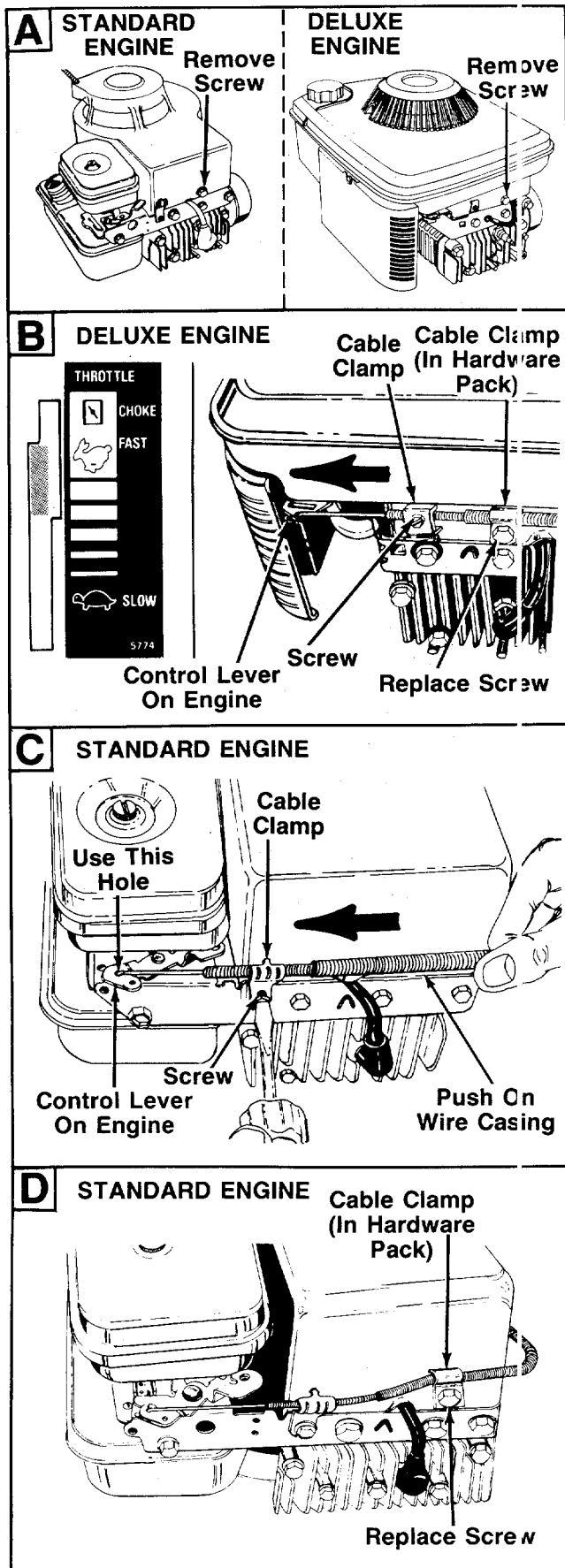

FIGURE 6.

ATTACHING THE THROTTLE CABLE (Hardware C)

Compare the engine on your mower to the engines shown in figure 6A to determine if it is a standard or a deluxe Briggs and Stratton engine. Follow the instructions which pertain to your unit.

1. Using a 7/16" wrench, remove the screw on the engine shown in figure 6A.
2. Place the throttle control lever on the handle in FAST position.

➡ **NOTE**

Deluxe engine: Move throttle control lever until it stops in FAST position (do not push all the way forward to CHOKE position). See figure 6B.

3. The throttle control cable is attached to the upper handle. Route the throttle control cable under the lower handle and inside the handle mounting bracket. Hook the "Z" end of the throttle control cable into the hole in the control lever on the engine.

➡ **NOTE**

Standard engine: Hook the cable into the arm on the control lever on the engine which has two holes, using the outside hole as shown in figure 6C.

4. Remove the screw on the cable clamp on the engine shown in figure 6B (deluxe engine) or 6C (standard engine). Slip the control casing under the clamp. Replace the screw, but do not tighten (cable must still move freely beneath the clamp).

➡ **NOTE**

Deluxe engine: The control casing goes under the clamp and above the screw as shown in figure 6B.

5. **Deluxe engine:** Slide the control lever on the engine as far toward the outside of the engine as it will go easily (just until resistance is felt) as shown in figure 6B. (Do not force it into the extreme outside position, which is the CHOKE position.) Tighten the screw to secure the throttle control cable in this position.

Standard engine: Place the control lever on the engine in the full open position by pushing it toward outside of the unit. Push the wire casing on the throttle control cable toward the control lever on the engine as shown in figure 6C as you tighten the screw on the cable clamp.

6. Loosen the screw on the clamp on the side of the engine. Secure the cable away from the muffler. Be careful not to bend or kink the cable. Tighten the screw.

7. Secure cable casing to the front of engine with cable clamp provided in hardware pack and screw removed from engine in step 1 as shown in figure 6B or 6D. Do not overtighten.

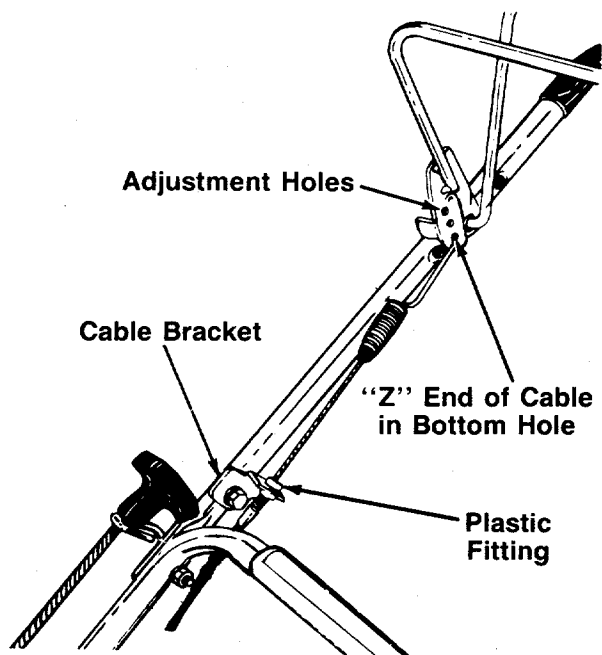

FIGURE 7.

ATTACHING THE DRIVE CLUTCH CONTROL CABLE

1. The drive clutch control cable is attached to the drive cover, and has a spring on one end. Route the clutch cable inside the handle mount bracket and under the lower handle. Hook the spring on the end of the cable into the bottom hole on the drive clutch control handle. See figure 7.
2. Pull down on the plastic cable casing, and slip the control wire through the slot in the cable bracket. Push the plastic fitting on the end of the cable casing into the cable bracket.



WARNING

Drive clutch adjustment must be checked before the unit is operated, as on page 10.

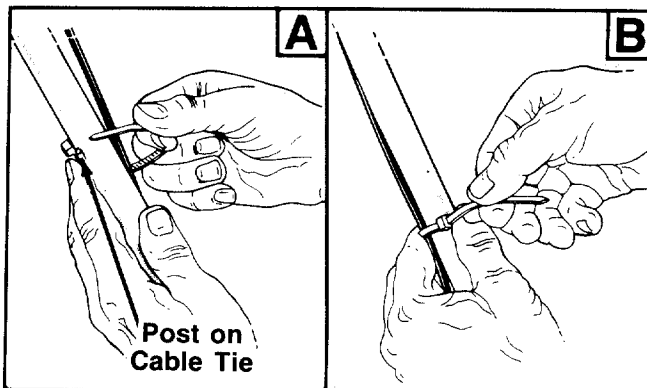

FIGURE 8.

SECURING THE CABLES (Hardware E)

Secure all cables to the handles as follows.

- A. Insert posts on cable ties into holes provided on the inside of the handles. Two go on each side of the lower handle (one near the top and one near the bottom), and one goes on the left side of upper handle. See figure 8A.
- B. Secure the cables with the cable ties. See figure 8B.
- C. Trim excess ends of cable ties.

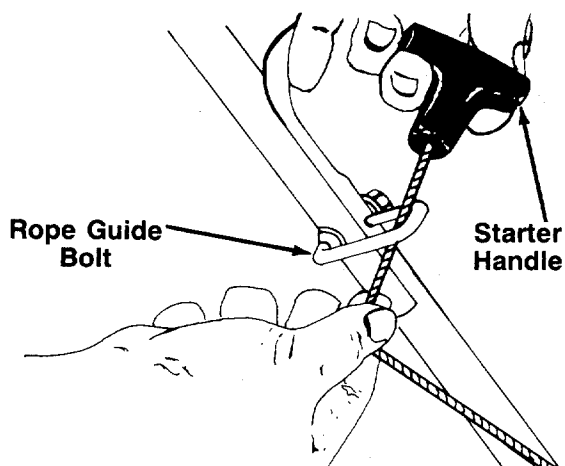

FIGURE 9.

ATTACHING THE STARTER ROPE

1. The starter rope is inside the top of the engine. Additional rope may be wound around the starter handle. If so, unwind the rope from the handle.
2. With the spark plug wire disconnected and grounded, depress the blade control handle and pull the rope out of the engine.
3. Slip the starter rope into the rope guide bolt as shown in figure 9.
4. Tighten the hex nut on the rope guide bolt securely.

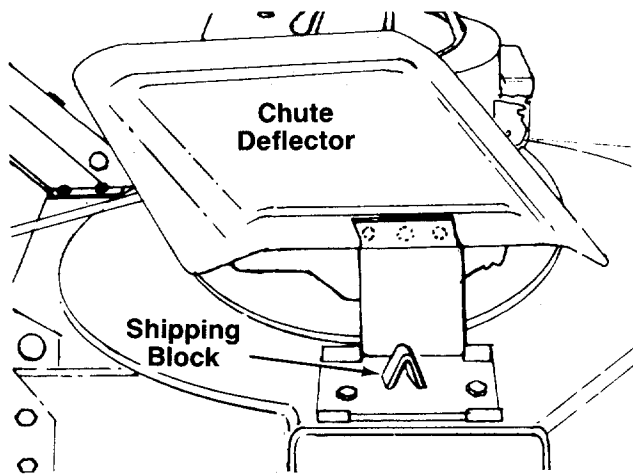

FIGURE 10.

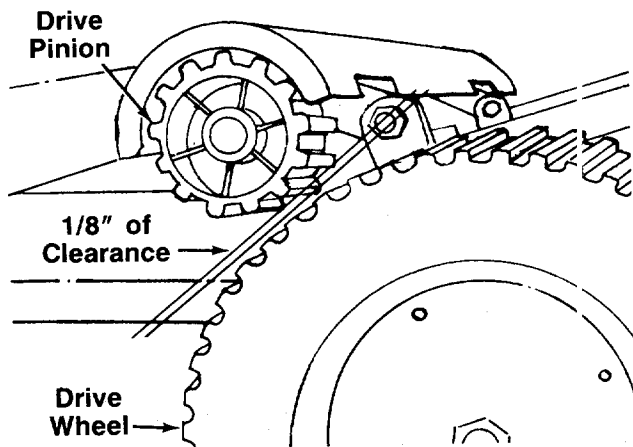

FIGURE 11.

FINAL ASSEMBLY OF MOWER (Hardware D)

1. If plastic plug is not already assembled, insert plastic plug into hole in the top rear of the deck by slipping one end of plug into hole, then pressing down on the other end of plug. Use a soft hammer if necessary.
2. The chute deflector on your mower is held in an upright position by a "V" block for shipping purposes only. This "V" block must be removed and discarded before the mower is put into operation. See figure 10.
 To remove the "V" block, pull the spring-loaded chute toward the engine. Remove the "V" block and carefully lower the chute into operating position, keeping fingers out of the way.
3. Attach hub caps (optional) to the wheels by lining up the four tabs on the hub caps with the four holes in the wheels. Push to lock in position.
4. Make certain all nuts and bolts are tightened securely.

CHECKING THE DRIVE CLUTCH ADJUSTMENT

Check the adjustment of the clutch cable. Correct adjustment is as follows.

The drive pinions should be approximately 1/8" from the drive wheels when the clutch is disengaged (clutch control handle is **not** squeezed against upper handle). See figure 11.

When the clutch control is engaged, the drive pinions should mesh with the gear tread tires.

If adjustment is needed, refer to adjustment section of this manual.

CONTROLS

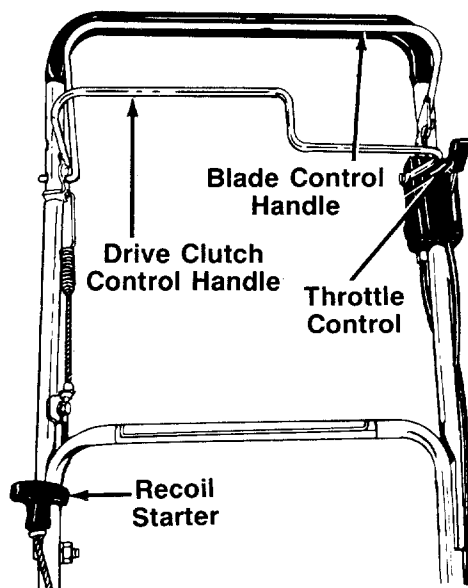

FIGURE 12.

BLADE CONTROL HANDLE

WARNING
 THIS CONTROL MECHANISM IS A
 SAFETY DEVICE. NEVER ATTEMPT
 TO BYPASS ITS OPERATIONS

The blade control handle is located on the upper handle of the mower. See figure 12. The blade control handle must be depressed in order to operate the unit. Release the blade control handle to stop the engine and blade.



The blade will be rotating whenever the engine is running.

THROTTLE CONTROL

The throttle control is located on the left side of the upper handle. It is used to regulate the engine speed.



The throttle control cannot be used to stop the engine.

RECOIL STARTER

The recoil starter handle is attached to the handle. See figure 12. Stand behind the unit in the operating position to start the unit.

DRIVE CLUTCH CONTROL

Squeezing the drive clutch control handle engages the drive mechanism to the rear wheels. Releasing the clutch control stops the rear wheels from driving. Release the drive clutch control to slow down when negotiating an obstacle, making a turn or stopping. See figure 12.

OPERATION



FIGURE 13.

Keep hands and feet away from the chute area on cutting deck. See figure 13.



For shipping purposes your mower is set with the wheels in a low cutting height position. For best results raise the cutting position until it is determined which height is best for your lawn. See cutting height adjustment section.

GAS AND OIL FILL-UP

Service the engine with gasoline and oil as instructed in the separate engine manual packed with your mower. Read instructions carefully.



Your unit has been shipped without oil; however, a small amount of oil may be present from the factory. Do not overfill.



Never fill fuel tank indoors, with engine running or until the engine has been allowed to cool for at least two minutes after running.

Before each use, check drive clutch adjustment. When the clutch handle is engaged, the black nylon drive pinions should mesh simultaneously with the gear tread tires. When the clutch handle is released, the pinions should clear the wheels by approximately 1/8". See drive clutch adjustment on page 13 for further details.

TO START ENGINE AND ENGAGE BLADE



When starting the unit for the first time, face the mower against a solid object such as a wall, fence, etc. Start the unit, and if it shows any signs of motion with the drive clutch control disengaged, shut the engine off immediately. Refer to page 13 for further instructions on the drive clutch adjustment.

BEFORE STARTING

1. Attach spark plug wire to spark plug.
2. **Deluxe Briggs and Stratton engines:** Open fuel shut-off valve. See figure 14.

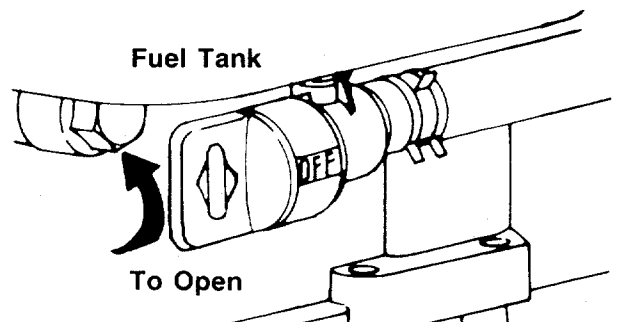

FIGURE 14.

3. Move the throttle control lever to FAST or START position.

NOTE

On units with deluxe Briggs and Stratton engines, move throttle control lever to CHOKE position.

4. Standing behind the unit, depress the blade control handle and hold it against the upper handle. Be certain the drive clutch handle is released.
5. Grasp the recoil starter handle and pull back rapidly, extending rope fully. Return it slowly to the rope guide bolt.
6. After engine starts, move throttle control to desired engine speed.

NOTE

If any problems are encountered, refer to the Trouble Shooting Chart on page 19.

TO STOP ENGINE AND BLADE

1. Release the blade control handle to stop the engine and blade.



The blade continues to rotate for a few seconds after the engine is shut off.

2. Disconnect the spark plug wire and ground it against the engine to prevent accidental starting while equipment is unattended.

USING YOUR ROTARY MOWER

Be sure that lawn is clear of stones, sticks, wire, or other objects which could damage lawn mower or engine. Such objects could be accidentally thrown by the mower in any direction and cause serious personal injury to the operator and others.

Operate a new engine at intermediate speeds and light load for the first few hours as you would a new automotive engine.

For best results, do not cut wet grass because it tends to stick to the underside of the mower, preventing proper discharge of grass clippings, and could cause you to slip and fall. New grass, thick grass or wet grass may require a narrower cut. Blade speed should be adjusted to the condition of the lawn.

The best mowing pattern is one that allows the clippings to discharge towards the uncut part of the lawn. This permits recutting of the clippings to further pulverize them. When cutting high weeds, discharge towards cut portion, then recut at right angles to first direction.

For best results, cut off one-third or less of the total length of the grass. Lawn should be cut in the fall as long as there is growth.

This mower is designed to be operated at full throttle to give you the best cut and do the most effective job of bagging the cut grass.

IMPORTANT

If you strike a foreign object, stop the engine. Remove wire from spark plug, thoroughly inspect the mower for any damage, and repair the damage before restarting and operating the mower. Extensive vibration of the mower during operation is an indication of damage. The unit should be promptly inspected and repaired.

ADJUSTMENTS



Do not at any time make any adjustment to lawn mower without first stopping engine and disconnecting spark plug wire.

CUTTING HEIGHT ADJUSTMENT

Model 282 (with height adjustment brackets)

An adjusting plate and thumb lever at each wheel position provides cutting height adjustment. Each adjusting plate has nine positions. Height of cut will be changed when the thumb lever is moved from one hole to another. Simply depress the lever towards wheel and move wheel and lever assembly to desired position. See figure 15.

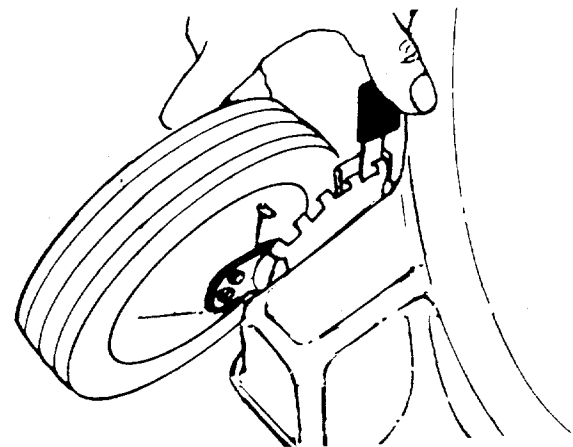

FIGURE 15.

Cutting height will be raised as the rear levers are lowered and the front levers are moved toward the front

of the unit. Cutting height will be lowered as the rear levers are raised and the front levers are moved toward the rear of the unit. All wheels must be positioned at the same relative height.

For rough or uneven lawns, move the wheels to a position which will give a higher cutting height.

Model 280 (without height adjustment brackets)

Adjustment may be made by removing and moving axle bolts to desired position. Cutting heights will be raised as axle bolts are moved to a lower hole and lowered as axle bolts are moved to a higher hole. All axle bolts must be mounted in the same relative position to the deck.

When changing the height of the front wheels, use the holes closest to the front of the deck. Belleville washers must be assembled on the inside and outside of the deck so that the cupped side of the washers are against the deck.

To change the height of the rear wheels, proceed as follows.

1. With an adjustable wrench, remove the hex nut, lock washer, axle bolt, belleville washer and rear wheel.
2. Reassemble in selected hole. The belleville washer must be assembled between the link and wheel bracket, with the cupped side of the washer against the deck. See figure 16.

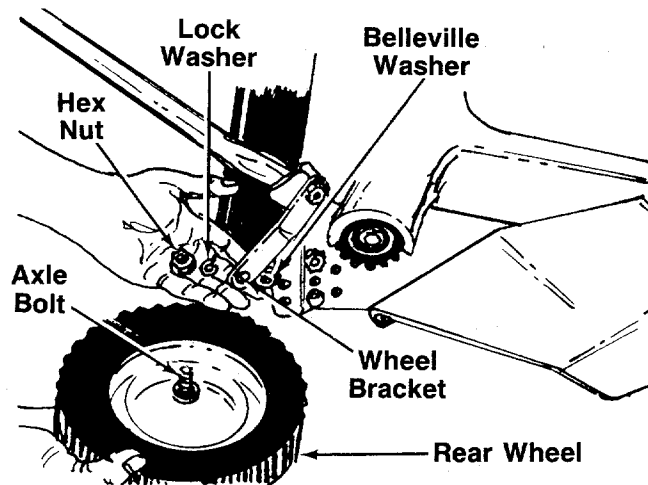

FIGURE 16.

DRIVE CLUTCH ADJUSTMENT

The drive pinions should be approximately 1/8" from the drive wheels when the clutch is disengaged (clutch handle is released). Refer to figure 11.

If there is not 1/8" of clearance, unhook the cable from the clutch handle and move it to the next higher adjustment hole provided. Refer to figure 7. Check to be certain there is 1/8" of clearance when the clutch is disengaged, and the drive pinions mesh with the wheels with the drive clutch engaged.

CHAIN ADJUSTMENT

Check for correct chain adjustment and alignment after first five to ten hours of operation. Adjust as follows:

1. Loosen (do not remove) the hex bolt on each side of the pinion pivot plate. See figure 17.

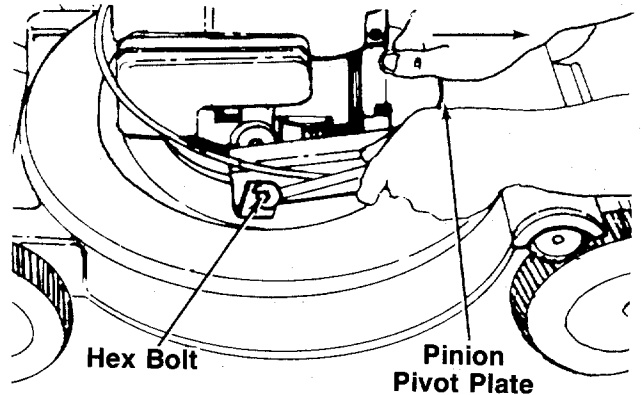

FIGURE 17.

2. Pull back on the left side of the pivot plate, by hand, until the proper chain tension is achieved. Tighten the hex bolt.
3. Pull back on the right side of the pivot plate until the clearance between the pinion and wheel is equal on both sides. Tighten the hex bolt.
4. Recheck for correct adjustment periodically.

THROTTLE

The throttle control wire assembly can be adjusted if necessary. Loosen the screw on the cable clamp closest to the control lever on engine. Adjust as instructed in step 5 of "Attaching the Throttle Control Cable" in Assembly Instructions.

CARBURETOR ADJUSTMENTS



If any adjustments are made to the engine while the engine is running (e.g. carburetor), keep clear of all moving parts. Be careful of heated surfaces and muffler.

Minor carburetor adjustment may be required to compensate for differences in fuel, temperature, altitude and load. Refer to the separate engine manual packed with your mower for carburetor adjustment information.



A dirty air cleaner will cause an engine to run rough. Be certain air cleaner is clean and attached to the carburetor before adjusting carburetor. Refer to the separate engine manual.

LUBRICATION



Always stop engine and disconnect spark plug wire before cleaning, lubricating or doing any kind of work on lawn mower.

Blade Control—Lubricate the pivot points on the blade control handle and the brake cable at least once a season with light oil. The blade control must operate freely in both directions.

Chute Deflector—The torsion spring and pivot point should be lubricated periodically with light oil to prevent any rust or binding. Deflector must work freely.

Wheels—Mower may be provided with ball bearing wheels. Lubricate at least once a season with light oil. Also, if the wheels are removed for any reason, lubricate the surface of the axle bolt and the inner surface of the wheel with light oil. A 4 oz. plastic bottle of light oil lubricant is available. Order part number 737-0170. Engine oil may also be used.

Engine—Follow engine manual for lubrication instructions.

Throttle—Periodically lubricate throttle control lever and throttle wire assembly with a few drops of light oil for ease of operation.

Chain—The chain should be lubricated periodically with a few drops of light oil to prevent any rust or binding. Use very little or no oil if unit is being used in a dusty or sandy area.

MAINTENANCE



NOTE

When tipping the unit, empty the fuel tank and keep engine spark plug side up.

TROUBLE SHOOTING

Refer to page 19 of this manual for trouble shooting information.

CUTTING BLADE

A. Removal for Sharpening or Replacement



Be sure to disconnect and ground the spark plug wire before working on the cutting blade to prevent accidental engine starting. Protect hands by using heavy gloves or a rag to grasp the cutting blade.

Remove the large bolt and lock washer which holds the blade and adapter to the engine crankshaft. Remove the blade and adapter from the crankshaft.

If the blade or blade adapter needs replacing, remove the two small bolts, lock washers and nuts which hold the blade to the adapter.



CAUTION

Periodically inspect the blade adapter for cracks, especially if you strike a foreign object. Replace when necessary.

B. Sharpening

Remove the cutting blade by following the directions of the preceding section.

When sharpening the blade, follow the original angle of grind as a guide. It is **extremely important** that each cutting edge receives an equal amount of grinding to prevent an unbalanced blade. An unbalanced blade will cause excessive vibration when rotating at high speeds, may cause damage to the mower and could break, causing personal injury.

It is recommended that the blade always be removed from the adapter for the best test of balance. The blade can be tested by balancing it on a round shaft screwdriver. Remove metal from the heavy side until it balances evenly.

C. Reassembly

Before reassembling the blade and the blade adapter to the unit, lubricate the engine crankshaft and the inner surface of the blade adapter with light oil. Lubricating the bolt holes, bolts and inner surface of the nuts with light oil is also recommended. A 4 oz. plastic bottle of light oil lubricant is available. Order part number 737-0170. Engine oil may also be used.

When replacing the blade, be sure to install the blade with the side of the blade marked "Bottom" (or with part number) facing the ground when the mower is in the operating position.

Blade Mounting Torque

3/8" Dia. Bolt 375 in. lb. min., 450 in. lb. max.

5/16" Dia. Bolt 150 in. lb. min., 250 in. lb. max.

To insure safe operation of your unit, all nuts and bolts must be checked periodically for correct tightness.

DECK

The underside of mower deck should be cleaned after each period of use as grass clippings, leaves, dirt and other matter will accumulate. This accumulation of grass clippings, etc., is undesirable as it will invite rust and corrosion and may cause an uneven discharge of grass clippings at the next cutting.

The deck may be cleaned by tilting the mower forward or on its side and scraping clean with a suitable tool or by washing with a stream of water from a garden hose.

 **NOTE**

Do not direct the stream of water at a hot engine as damage to the engine may result.

ENGINE OIL

Refer to the separate engine manual for all engine maintenance instructions.

Maintain **engine oil** as instructed in the separate engine manual packed with your unit. Read and follow instructions carefully.

Service **air cleaner** every 25 hours under normal conditions. Clean every few hours under extremely dusty conditions. Poor engine performance and flooding usually indicates that the air cleaner should be serviced. To service the air cleaner, refer to the separate engine manual packed with your unit.

The **spark plug** should be cleaned and the gap reset once a season. Spark plug replacement is recommended at the start of each mowing season; check engine manual for correct plug type and gap specifications.

OFF-SEASON STORAGE

The following steps should be taken to prepare lawn mower for storage.

1. Clean and lubricate mower thoroughly as described in the lubrication instructions.
2. Refer to engine manual for correct engine storage instructions.
3. Coat mower's cutting blade with chassis grease to prevent rusting.
4. Store mower in a dry, clean area.

 **NOTE**

When storing any type of power equipment in an unventilated or metal storage shed, care should be taken to rustproof the equipment. Using a light oil or silicone, coat the equipment, especially chains, springs, cables and all moving parts.

 **NOTE**

The use of any accessory on this Rotary Mower other than those manufactured by the mower manufacturer is **not** recommended.

GRASS CATCHER Model 066 is available as optional equipment for the mower shown in this manual.



1. DO NOT operate the mower without the entire grass catcher or chute deflector in place.
2. DO NOT operate the mower without the protective shield on the rear of the deck in place.

 **NOTE**

Under normal usage bag material is subject to wear and should be checked periodically. Be sure any replacement bag complies with the mower manufacturer's recommendations.

For replacement bags, use only factory authorized replacement bag No. 764-0217.

Models 280 and 282

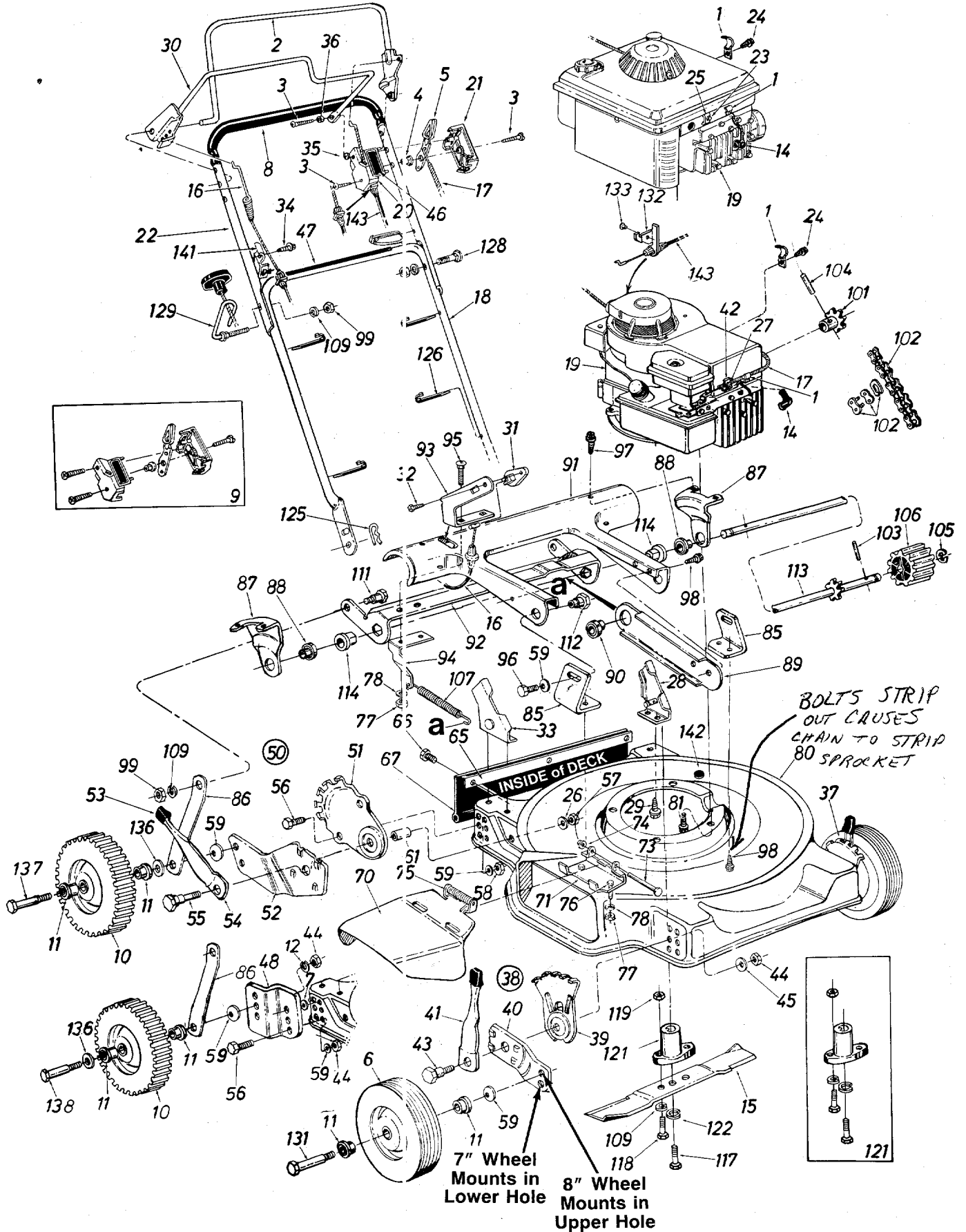

Models 280 and 282

PARTS LIST FOR MODELS 280 AND 282 ROTARY MOWERS

REF. NO.	PART NO.	COLOR CODE	DESCRIPTION	NEW PART	REF. NO.	PART NO.	COLOR CODE	DESCRIPTION	NEW PART
1	12894		Casing Clamp		51	14764		Index Plate (282)	
2	14321		Control Handle Ass'y.—L.H.		52	14765		Pivot Bar—R.H. (282)	
3	710-0796		Truss Mach. Hi-B Tap Scr. #12 x 1.5"			14766		Pivot Bar—L.H. (282) (Not Shown)	
4	731-0524		Control Disc Pin		53	720-0190		Spring Lever Knob (282)	
5	731-0528		Throttle Control Lever		54	732-0417		Spring Lever (282)	
6	**		Front Wheel Ass'y. Comp.		55	738-0528		Shld. Bolt .50 Dia. x .433 (282)	
7	736-0117		Fl-Wash. .38" I.D. x .620" O.D. (280 Only)		56	710-0216		Hex Bolt 3/8-16 x .75	
8	718-0145		Grip (Optional)		57	712-0158		Hex Cent. L-Nut 5/16-18 Thd.	
9	753-0430		Control Housing Comp.	N	58	712-0798		Hex Nut 3/8-16 Thd.*	
10	734-1026		Rear Wheel Ass'y. Comp.		59	736-0105		Bell-Wash. .40 I.D. x .88 O.D.	
11	741-0180		Fl. Ball Brg. 1/2" I.D.		61	750-0503		Spacer .383 I.D. x .503 O.D.	
12	736-0169		L-Wash. 3/8" I.D.*		65	14846		Retaining Strip	
13	†		Hub Cap		66	710-0776		Hex AB-Tap Scr. 1/4 x .62	
14	735-0639		Spark Plug Insulator		67	731-0575		Rear Flap Ass'y.	
15	742-0125		22" Blade		70	14944		Chute Deflector Ass'y.	
16	746-0625		Clutch Cable w/Spring—32"		71	11130		Adapter Plate	
17	746-0632		Throttle Wire—53"		73	711-0555		Pivot Pin	
18	749-0373		Lower Handle		74	726-0106		Push Nut 1/4"	
19	—		Engine		75	732-0253		Torsion Spring	
20	731-0816		Clutch Panel Half		76	710-0289		Hex Bolt 1/4-20 x .50 Lg.*	
21	731-0817		Control Panel Half		77	712-0287		Hex Nut 1/4-20 Thd.*	
22	749-0536		Upper Handle		78	736-0329		L-Wash. 1/4 I.D.*	
23	710-0227		Hex AB-Tap Scr. #8 x .50"		80	14999	463	22" Deck Ass'y.	
24	710-0429		Hex B-Tap Scr. #10 x .38"		81	710-0654		Hex TT-Tap Scr. 3/8-16 x 1.0	
25	751-0442		Casing Clamp		85	14759		Pivot Brkt.	
26	736-0242		Bell-Wash. 5/16" I.D.		86	14760		Link 4.58	
27	710-0429		Hex "B"-Tap Scr. #10 x .38"		87	14757		Axle Brkt.	
28	12935		Handle Brkt. Ass'y.—L.H.		88	741-0180		Fl. Ball Brg. 1/2" I.D.	
29	710-0603		Hex B-Tap Scr. 5/16-18 x .5"		89	14877		Brg. Support	
30	16391		S.P. Bail Ass'y.		90	741-0180		Fl. Ball Brg. 1/2" I.D.	
31	746-0606		Barrel Cable Hold-Down R.H.		91	16319		Pinion-Pivot Cover	
32	710-0429		B-Tap Scr. #10 x .38 Lg.		92	16332		Drive Engagement Cam	
33	12936		Handle Brkt. Ass'y.—R.H.		93	16534		Engagement Arm—L.H.	
34	710-0726		Hex Wash. AB-Tap Scr. 5/16 x .75"		94	16536		Spring Bracket	
35	736-0370		Spr-Wash. .206 I.D. x .448		95	710-0134		Carriage Bolt 1/4-20 x .62	
36	750-0649		Spacer .23 I.D. x .30 O.D.		96	710-0168		Hex Bolt 3/8-16 x .50 Lg.*	
37	14579		Front Height Adj. Ass'y.—L.H. (282)		97	710-0776		Hex AB-Tap Scr. 1/4 x .62	
38	14578		Front Height Adj. Ass'y.—R.H. (282)		98	710-0892		Hex AB-Tap 1/4 x .62"	
39	15261		Height Adj. Plate (282)		99	712-0267		Hex Nut 5/16-18 Thd.*	
40	15262		Pivot Bar (282)		101	713-0308		10T Sprocket Ass'y.	
41	14832		Spring Lever Ass'y. w/Knob (282)		102	713-0311		#48 Chain 1/2" Pitch 50 Links	
42	751-0369		Casing Clamp			713-0122		Master Link (Service Only)	
43	738-0507		Shld. Bolt .50 Dia. x .430 (282)		103	715-0246		Spring Pin Spir. 3/16 Dia. x 1.25	
44	712-0798		Hex Nut 3/8-16 Thd.*		104	715-0247		Spring Pin Spir. 3/16 Dia. x 1.0	
45	736-0356		Bell-Wash. .39 I.D. x 1.38 O.D.		105	716-0104		E-Ring For .500 Dia. Shaft	
46	777-5774		Control Label		106	731-0393		Drive Pinion	
47	777-5776		Instruction Label		107	732-0428		Extension Spring 4.25 Lg.	
48	14761		Wheel Brkt. (280 Only)		109	736-0119		L-Wash. 5/16 I.D.*	
50	14762		Rear Height Adj. Ass'y.—R.H. (282)		111	738-0155		Shld. Bolt .437 Dia. x .162	
	14763		Rear Height Adj. Ass'y.—L.H. (Not Shown) (282)		112	738-0529		Shld. Nut .625 Dia. x .165	
					113	738-0530		Pinion Shaft w/7T Sprocket	
					114	741-0484		Fl. Ball Brg. .501 I.D.	
					117	710-0331		Hex Bolt 3/8-24 x 2.25	
					118	710-0888		Hex Bolt 5/16-24 x 1.0—Spec.	
					119	712-0123		Hex Nut 5/16-24 Thd.	
					121	753-0348		Blade Adapter Kit	

Models 280 and 282

PARTS LIST FOR MODELS 280 AND 282 ROTARY MOWERS (CONTINUED)

REF. NO.	PART NO.	COLOR CODE	DESCRIPTION	NEW PART
122	736-0217		L-Wash. 3/8 I.D.—H.D.	N
125	714-0104		Intern. Cot. Pin 5/16 Dia.	
126	726-0240		Cable Tie	
128	710-0671		Curved Carriage Bolt 5/16-18 x 1.38" Lg.	
129	710-0842		Rope Guide Bolt	
131	738-0102		Front Axle Bolt (282 Only)	
	738-0213		Front Axle Bolt (280 Only)	
132	14924		Cable Bracket	
133	728-0171		Pop Rivet .156" Dia. x .379	
136	736-0192		Fl-Wash. .531 I.D. x .93 O.D.	
137	738-0144		Rear Axle Bolt (282 Only)	
138	738-0533		Rear Axle Bolt (280 Only)	
141	16309		Cable Brkt.	
142	731-0564		Plastic Plug	
143	746-0476		Control Cable—39" (Green)	
—	8280-000-7		Hardware Pack	

**FRONT WHEEL CHART

	Waffle Tread	Twinline Tread	Smooth
7" x 1.50"	734-0893	734-0876	734-0842
8" x 1.75"	734-0894	734-0661	734-0843

*For faster service obtain standard nuts, bolts and washers locally. If these items cannot be obtained locally, order by part number and size as shown on parts list.

If color or finish is important when ordering parts, use the appropriate color code shown below [i.e. (part no.)-463 for Topflite Red Finish].

†Hub Caps Available

Color	Part No.
Red	731-0124
Orange	731-0254
Black	731-0354
Gray	731-0355

Color Codes

312—White	463—Topflite Red
436—Radiant Yellow	480—Brilliant Green
447—Patina Silver	483—Charcoal Grey
452—Black	499—Beige
456—Radiant Tangerine	606—Majestic Orange
460—Green Flake	629—Silver Flake

➔ NOTE

This instruction manual covers various models and all specifications shown do not necessarily apply to your model. Specifications subject to change without notice or obligation.

NOTE: The engine is not under warranty by the mower manufacturer. . . If repairs or service is needed on the engine, please contact your nearest authorized engine service outlet. Check the "Yellow Pages" of your telephone book under "Engines—Gasoline."



Trouble Shooting Chart

Symptom	Possible Causes	Corrective Action
1 Engine fails to start	<p>A Blade control handle disengaged</p> <p>B Check fuel tank for gas</p> <p>C Fuel shut-off valve closed (on units so equipped)</p> <p>D Spark plug lead wire disconnected.</p> <p>E Throttle control lever not in the starting position</p> <p>F Faulty spark plug</p> <p>G Carburetor improperly adjusted, engine flooded</p> <p>H Old stale gasoline</p> <p>I Engine brake engaged</p>	<p>A Engage blade control handle.</p> <p>B Fill tank if empty.</p> <p>C Open fuel shut-off valve.</p> <p>D Connect lead wire.</p> <p>E Move throttle lever to start position.</p> <p>F Clean, adjust gap or replace.†</p> <p>G Remove spark plug, dry the plug, crank engine with plug removed, and throttle in off position. Replace spark plug and lead wire and resume starting procedures.</p> <p>H Drain and refill with fresh gasoline.</p> <p>I Follow starting procedure.</p>
2 Hard starting or loss of power	<p>A Spark plug wire loose</p> <p>B Carburetor improperly adjusted</p> <p>C Dirty air cleaner</p>	<p>A Connect and tighten spark plug wire.</p> <p>B Adjust carburetor.†</p> <p>C Clean air cleaner.†</p>
3 Operation erratic	<p>A Dirt in gas tank</p> <p>B Dirty air cleaner</p> <p>C Water in fuel supply</p> <p>D Vent in gas cap plugged</p> <p>E Carburetor improperly adjusted</p>	<p>A Remove the dirt and fill tank with fresh gas.</p> <p>B Clean air cleaner.†</p> <p>C Drain contaminated fuel and fill tank with fresh gas.</p> <p>D Clear vent or replace gas cap.</p> <p>E Adjust carburetor.†</p>
4 Occasional skip (hesitates) at high speed	<p>A Carburetor idle speed too slow</p> <p>B Spark plug gap too close</p> <p>C Carburetor idle mixture adjustment improperly set</p>	<p>A Adjust carburetor.†</p> <p>B Adjust to .030".</p> <p>C Adjust carburetor.†</p>
5 Idles poorly	<p>A Spark plug fouled, faulty, or gap too wide</p> <p>B Carburetor improperly adjusted</p> <p>C Dirty air cleaner</p>	<p>A Reset gap to .030" or replace spark plug.</p> <p>B Adjust carburetor.†</p> <p>C Clean air cleaner.†</p>
6 Engine overheats	<p>A Carburetor not adjusted properly</p> <p>B Air flow restricted</p> <p>C Engine oil level low</p>	<p>A Adjust carburetor.†</p> <p>B Remove blower housing and clean.†</p> <p>C Fill crankcase with the proper oil.</p>
7 Excessive vibration	<p>A Cutting blade loose or unbalanced</p> <p>B Bent cutting blade</p>	<p>A Tighten blade and adapter. Balance blade.</p> <p>B Replace blade.</p>

†Refer to separate engine manual packed with your unit.

Note: For repairs beyond the minor adjustments listed above, contact your local authorized service dealer.

PARTS INFORMATION

POWER EQUIPMENT PARTS AND SERVICE

Parts and service are available through the authorized service firms listed below. All orders should specify the model number of your unit, part numbers, description of parts and the quantity of each part required.

NOTE: If any parts are found to be missing or defective upon assembly of this unit, write to advise the factory so that immediate replacement can be made.

ALABAMA	BIRMINGHAM
Auto Electric & Carburetor Co.	2625 4th Ave. S. \$5233
ARKANSAS	NORTH LITTLE ROCK
Sutton's Lawn Mower Shop.	5301 Roundtop Drive Box 368, Rt. 4 72117
CALIFORNIA	PORTERVILLE
Billious	75 North D Street \$3257
COLORADO	DENVER
Spitzer Industrial Products Co.	6601 N. Washington St. \$0229
FLORIDA	JACKSONVILLE
Radco Distributors	4909 Victor St. Box 5459 \$2207
	HIALEAH
Small Eng. Dist.	7995 W. 26th Court \$3016
GEORGIA	EAST POINT
East Point Cycle & Key Inc.	2834 Church St. \$0344
ILLINOIS	LYONS
Keen Edge Co.	8615 Ogden Ave. \$0534
INDIANA	ELKHART
Parts & Sales Inc.	2101 Industrial Pkwy. 46516
IOWA	DUBUQUE
Power Lawn & Garden Equip.	2551 J.F. Kennedy. \$2001
LOUISIANA	NEW ORLEANS
Suhren Engine Co.	8330 Earhart Blvd. 70118
MARYLAND	TAKOMA PARK
Center Supply Co.	6867 New Hampshire Ave. 20912
MASSACHUSETTS	SPRINGFIELD
Morton B. Collins Co.	300 Birnie Ave. 01107
MICHIGAN	LANSING
Lorenz Service Co.	2500 S. Pennsylvania 48910
	MOUNT CLEMENS
Power Equipment Dist.	340 Hubbard 48043
MINNESOTA	HOPKINS
Hance Distributing Inc.	420 Excelsior Ave. W. 55343
MISSOURI	EARTH CITY
Oscar Wilson Engine & Parts	4159 Shoreline Dr. \$3045
	KANSAS CITY
Automotive Equip. Service	3117 Holmes St. \$4109
	ST. JOSEPH
Ross-Frazier Supply Co.	8th and Monterey. \$4503
	ST. LOUIS
Henzler, Inc.	2015 Lemay Ferry Rd. \$3125
NEW JERSEY	ALLOWAY
Piersons	Canal St. 08001
NEW MEXICO	ALBUQUERQUE
Spitzer Eng. & Parts Co.	1023 Third Ave. N.W. \$7103

BRIGGS AND STRATTON, TECUMSEH AND PEERLESS PARTS AND SERVICE

Briggs & Stratton, Tecumseh and Peerless parts and service should be handled by your nearest authorized engine service firm. Check the yellow pages of your telephone directory under the listing **Engines—Gasoline**, Briggs & Stratton or Tecumseh Lauson.

NEW YORK	CARTHAGE
Gamble Dist., Inc.	West End Ave. 13619
NORTH CAROLINA	GREENSBORO
Dixie Sales Company	335 N. Green 27402
OHIO	CARROLL
Stebe's Mid-State Mower Supply	Box 366, 71 High St. 43112
	CLEVELAND
Bleckrie, Inc.	7900 Lorain Ave. 44102
	WADSWORTH
National Central	687 Seville Rd. 44281
	YOUNGSTOWN
Burton Supply Co.	1301 Logan Ave. Box 929 44501
OREGON	PORTLAND
Kenton Supply Co.	8216 N. Denver Ave. 97217
PENNSYLVANIA	HARRISBURG
EECO Inc.	4021 N. 6th St. 17110
	WILLOW GROVE
Thompson Rubber Co.	850 Davisville Rd. 19090
	PITTSBURGH
Bluemont Co.	11125 Frankstown Rd. 15235
	PUNXSUTAWNEY
Frank Roberts & Sons	R.D. 2 15767
	SCRANTON
Scranton Auto Ignition Co.	1133-35 Wyoming Ave. 18509
TENNESSEE	KNOXVILLE
Ace Distributors	2103 Magnolia 37919
	MEMPHIS
American Sales & Service, Inc.	3035-43 Bellbrook 38116
TEXAS	DALLAS
Marr Brothers, Inc.	423 E. Jefferson 75203
	FORT WORTH
Woodson Sales Corp.	6733 Baker Blvd. Hwy. 10 76118
	SAN ANTONIO
Engine House Inc.	8610 Botts Lane P.O. Box 17867 78217
UTAH	SALT LAKE CITY
Powered Products	1661 N. Beck St. 84116
VIRGINIA	ASHLAND
RBI Corp.	101 Cedar Ridge Dr. 23005
WASHINGTON	SEATTLE
Equip. Northwest	1410 14th Ave. 98122
WISCONSIN	MILWAUKEE
Wisconsin Magneto Inc.	4727 N. Teutonia St. 53209

WARRANTY PARTS AND SERVICE POLICY

(0686)

The purpose of warranty is to protect the customer from defects in workmanship and materials, defects which are NOT detected at the time of manufacture. It does not provide for the unlimited and unrestricted replacement of parts. Use and maintenance are the responsibility of the customer. The manufacturer cannot assume responsibility for conditions over which it has not control. Simply put, if it's the manufacturer's fault, it's the manufacturer's responsibility; if it's the customer's fault, it's the customer's responsibility.

CLAIMS AGAINST THE MANUFACTURER'S WARRANTY

INCLUDES:

1. Replacement of Missing Parts on new equipment.
2. Replacement of Defective Parts within the warranty period.
3. Repair of Defects within the warranty period.

All claims MUST be substantiated with the following information:

1. Model Number, Serial Number and/or Data Code of unit involved.
2. Date unit was purchased or first put into service.
3. Date of Failure.
4. Nature of Failure.