

\$1.00

OWNER'S GUIDE

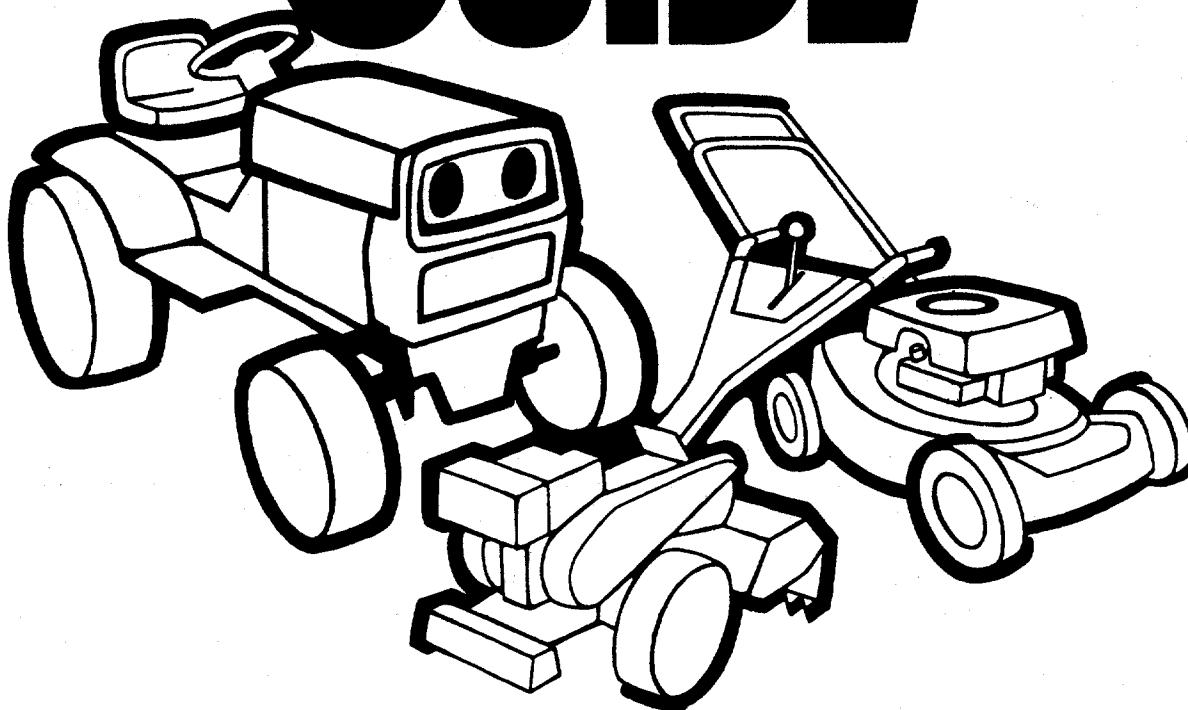

**21"
CONVERTIBLE
ROTARY
MOWERS**

Model Numbers

127-182-000 *No BAG*

127-192-000

190-067

IMPORTANT: Read Safety Rules and Instructions Carefully

INDEX

Slope Gauge	3
Contents of Hardware Pack	4
Rules for Safe Operation	5
Assembly	6
Controls	12
Operation	13
Adjustments	15
Lubrication	15
Maintenance	16
Off-Season Storage	18
Illustrated Parts	20, 23
Repair Parts List	21, 22, 23
Trouble Shooting	24
Parts Information	Back Cover

Dear Customer,

So often throughout the year we are all in a rush to meet our daily obligations.

However, we at MTD Products Inc are taking a quick moment out to say...

"Thank you for your business."

Sincerely,
MTD PRODUCTS INC



INSTRUCTIONS GIVEN WITH THIS SYMBOL ARE FOR PERSONAL SAFETY. BE SURE TO FOLLOW THEM.

LIMITED WARRANTY

For one year from the date of original retail purchase, MTD PRODUCTS INC will either repair or replace, at its option, free of charge, F.O.B. factory or authorized service firm, any part or parts found to be defective in material or workmanship. Transportation charges for the movement of any power equipment unit or attachment are the responsibility of the purchaser. Transportation charges for any parts submitted for replacement under this warranty must be paid by the purchaser unless such return is requested by MTD PRODUCTS INC.

This warranty will not apply to any part which has become inoperative due to misuse, excessive use, accident, neglect, improper maintenance, alterations, or unless the unit has been operated and maintained in accordance with the instructions furnished. This warranty does not apply to the engine, motor, battery, battery charger or component parts thereof. Please refer to the applicable manufacturer's warranty on these items.

This warranty will not apply where the unit has been used commercially.

Warranty service is available through your local authorized service dealer or distributor. If you do not know the dealer or distributor in your area, please write to the Customer Service Department of MTD.

The return of a complete unit will not be accepted by the factory unless prior written permission has been extended by MTD.

This warranty gives you specific legal rights. You may also have other rights which vary from state to state.

WARNING: This unit is equipped with an internal combustion engine and should not be used on or near any unimproved forest-covered, brush-covered or grass-covered land unless the engine's exhaust system is equipped with a spark arrester meeting applicable local or state laws (if any). If a spark arrester is used, it should be maintained in effective working order by the operator.

In the State of California the above is required by law (Section 4442 of the California Public Resources Code). Other states may have similar laws. Federal laws apply on federal lands. A spark arrester muffler is available at your nearest engine authorized service center.

USE THIS SHEET AS A GUIDE TO DETERMINE SLOPES WHERE YOU MAY NOT OPERATE SAFELY.

SLOPE GAUGE

(Keep this sheet in a safe place for future reference.)

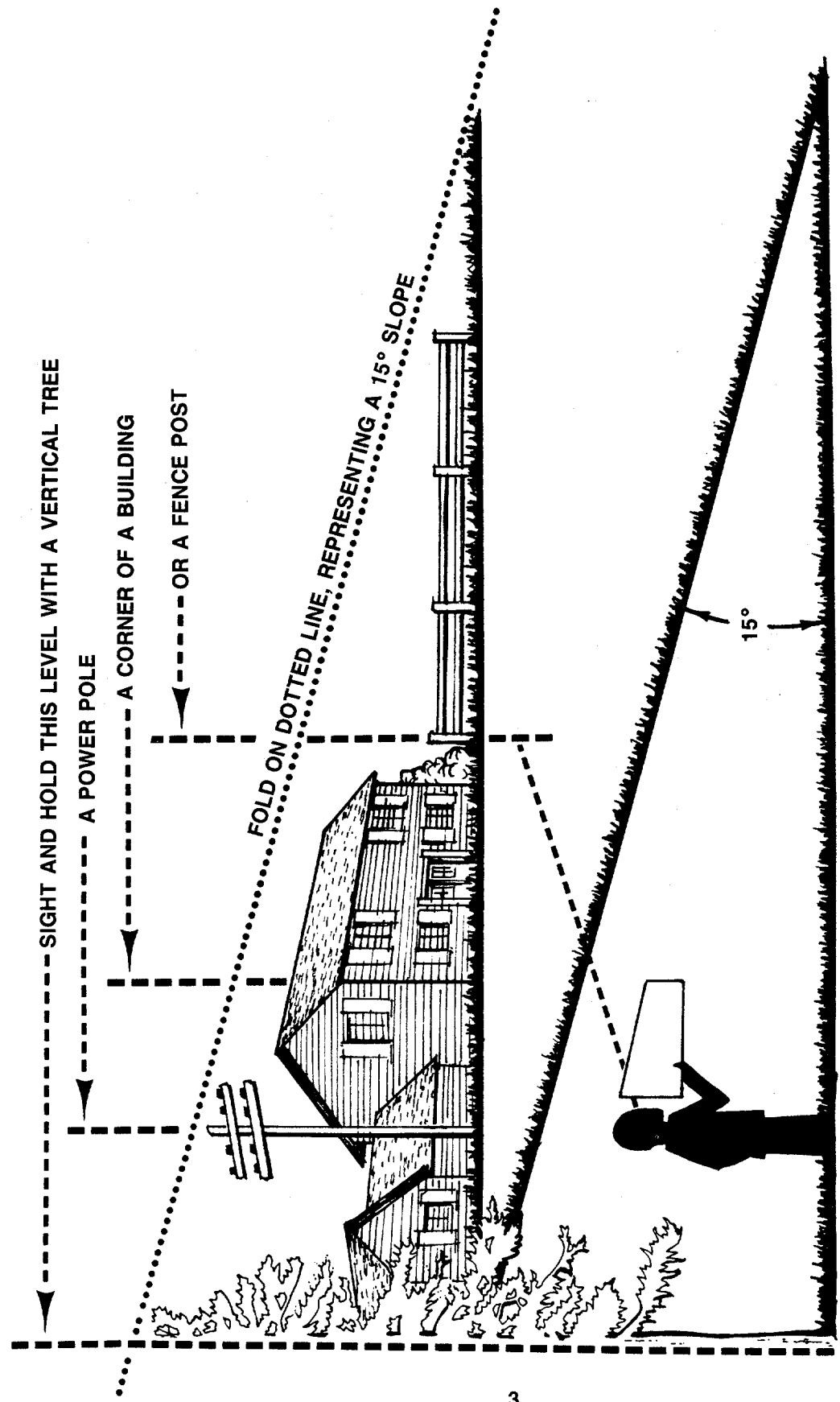

Do not mow on inclines with a slope in excess of 15 degrees (a rise of approximately 2½ feet every 10 feet). A riding mower could overturn and cause serious injury. If operating a walk-behind mower on such a slope, it is extremely difficult to maintain your footing and you could slip, resulting in serious injury.

Operate RIDING mowers up and down slopes, never across the face of slopes.

Operate WALK-BEHIND mowers across the face of slopes, never up and down slopes.

CONTENTS OF HARDWARE PACK

Remove this sheet from your owner's manual and lay the hardware on the illustration for identification purposes. After assembly, keep the Slope Gauge which is on the reverse side of this sheet for future use.
(Hardware pack may contain extra items which are not used on your unit.)

A ATTACHING THE LOWER HANDLE

Hairpin Clips

B ATTACHING THE UPPER HANDLE

Rope Guide Bolt
Curved Head Bolt
Split Washers 5/16" I.D.
Hex Nuts 5/16-18 Thread

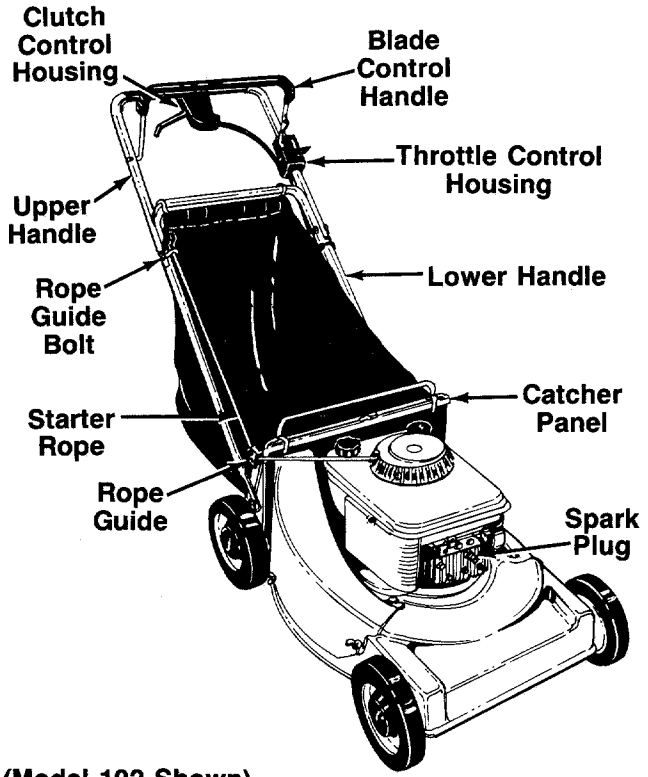

(Model 192 Shown)
PARTS IDENTIFICATION

C ATTACHING THE DRIVE CLUTCH CONTROL CABLE

Phillips Head Screws

D ATTACHING THE THROTTLE CABLE

Cable Clamp
Plastic Cap

F FINAL ASSEMBLY

Plastic Plug

G ATTACHING THE CHUTE DEFLECTOR (Model 182 Only)

Flat Washers 1/4" I.D.
Wing Nuts

E SECURING THE CABLES

Cable Ties

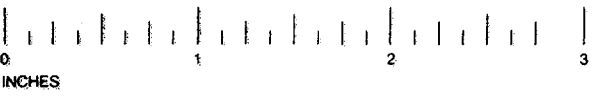

Cut Along

his Line

IMPORTANT

RULES FOR SAFE OPERATION



THIS SYMBOL POINTS OUT IMPORTANT SAFETY INSTRUCTIONS WHICH, IF NOT FOLLOWED, COULD ENDANGER THE PERSONAL SAFETY AND/OR PROPERTY OF YOURSELF AND OTHERS. READ AND FOLLOW ALL INSTRUCTIONS IN THIS MANUAL BEFORE ATTEMPTING TO OPERATE YOUR LAWN MOWER. FAILURE TO COMPLY WITH THESE INSTRUCTIONS MAY RESULT IN PERSONAL INJURY. WHEN YOU SEE THIS SYMBOL—  **HEED ITS WARNING.**



DANGER

Your lawn mower was built to be operated according to the rules for safe operation in this manual. As with any type of power equipment, carelessness or error on the part of the operator can result in serious injury. If you violate any of these rules, you may cause serious injury to yourself or others.



TRAINING

1. Read this owner's manual carefully in its entirety before attempting to assemble or operate this machine. Be completely familiar with the controls and the proper use of this machine before operating it. Keep this manual in a safe place for future and regular reference and for ordering replacement parts.
2. Your rotary mower is a precision piece of power equipment, not a plaything. Therefore, exercise extreme caution at all times.
3. Never allow children to operate a power mower. Only persons well acquainted with these rules of safe operation should be allowed to use your mower.
4. Keep the area of operation clear of all persons, particularly small children and pets. Stop engine when they are in the vicinity of your mower to help prevent blade contact or thrown object injury. Although the area of operation should be completely cleared of foreign objects, an object may have been overlooked and could be accidentally thrown by the mower in any direction and cause serious personal injury to the operator or any others allowed in the area.



PREPARATION

1. Thoroughly inspect the area where the equipment is to be used. Remove all stones, sticks, wire, bones and other foreign objects which could be picked up and thrown by the mower in any direction and cause serious personal injury to the operator or any others allowed in the area.
2. Always wear safety glasses or eye shields during operation or while performing an adjustment or repair, to protect eyes from foreign objects that may be thrown from the machine in any direction.
3. Wear sturdy, rough-soled work shoes and close-fitting slacks and shirts to avoid entanglement in the moving parts. Never operate a unit in bare feet, sandals, or sneakers.
4. Check the fuel before starting the engine. Gasoline is an extremely flammable fuel. Do not fill the gasoline tank indoors, while the engine is running, or until engine has been allowed to cool for two minutes after running. Replace gasoline cap securely and wipe off any spilled gasoline before starting the engine as it may cause a fire or explosion.
5. Disengage the self-propelled mechanism or drive clutch on units so equipped before starting the engine.
6. The blade control handle is a safety device. Never attempt to bypass its operation. Doing so makes the safety device inoperative and may result in personal injury through contact with the rotating blade. The blade control handle must operate easily in both directions.
7. Never attempt to make a wheel or cutting height adjustment while the engine is running.
8. Never operate the equipment in wet grass. Always be sure of your footing. A slip and fall can cause serious personal injury. Keep a firm hold on the handle and walk, never run. Mow only in daylight or in good artificial light.

9. For your safety, use the slope gauge included as part of this manual to measure slopes before operating this unit on a sloped or hilly area. If the slope is greater than 15° as shown on the slope gauge, do not operate this unit on that area or serious injury could result.



OPERATION

1. Do not change the engine governor settings or overspeed the engine. Excessive engine speeds are dangerous.
2. Do not put hands or feet near or under rotating parts. Keep clear of the discharge opening at all times as the rotating blade can cause injury.
3. Stop the blade when crossing gravel drives, walks or roads.
4. After striking a foreign object, stop the engine, remove the wire from the spark plug, and thoroughly inspect the mower for any damage. Repair the damage before restarting and operating the mower.
5. If the equipment should start to vibrate abnormally, stop the engine and check immediately for the cause. Vibration is generally a warning of trouble.
6. Shut the engine off and wait until the blade comes to a complete stop before removing the grass catcher or unclogging the chute. The cutting blade continues to rotate for a few seconds after the engine is shut off. Never place any part of the body in the blade area until you are sure the blade has stopped rotating.
7. Before cleaning, repairing or inspecting, make certain the blade and all moving parts have stopped. Disconnect the spark plug wire, and keep the wire away from the spark plug to prevent accidental starting.
8. Do not run the engine indoors.
9. Mow across the face of slopes, never up-and-down. Exercise extreme caution when changing direction on slopes. Do not mow excessively steep slopes. Always be sure of your footing. A slip and fall can cause serious personal injury.
10. Never operate mower without proper guards, plates or other safety protective devices in place.
11. Do not operate this mower with the chute door open, unless the complete grass catcher is properly mounted on the mower.



MAINTENANCE AND STORAGE

1. Check the blade and engine mounting bolts at frequent intervals for proper tightness.
2. Keep all nuts, bolts, and screws tight to be sure the equipment is in safe working condition.
3. Never store the equipment with gasoline in the tank inside of a building where fumes may reach an open flame or spark. Allow the engine to cool before storing in any enclosure.
4. To reduce fire hazard, keep the engine free of grass, leaves, or excessive grease.
5. Check the grass catcher bag frequently for wear or deterioration. For safety protection, replace only with new bag meeting original equipment specifications.

➔ **IMPORTANT:** This unit is shipped WITHOUT GASOLINE or OIL. After assembly, service engine with gasoline and oil as instructed in the separate engine manual packed with your unit.

➔ **NOTE:** Reference to right or left hand side of the mower is observed from the operating position. Refer to parts identification on page 4 for location of parts when assembling the mower.

ASSEMBLY INSTRUCTIONS

This owner's manual covers both side discharge (Model 182) and top discharge (Model 192) rotary mowers. Follow only the instructions which pertain to your style mower.

Tools Required for Assembly

- (1) Pair of Pliers
- (1) Phillips Head Screwdriver
- (1) 1/2" Wrench*
- (1) 5/16" Wrench or Nutdriver*
- (1) 7/16" Wrench*

*Or one 6" Adjustable Wrench.

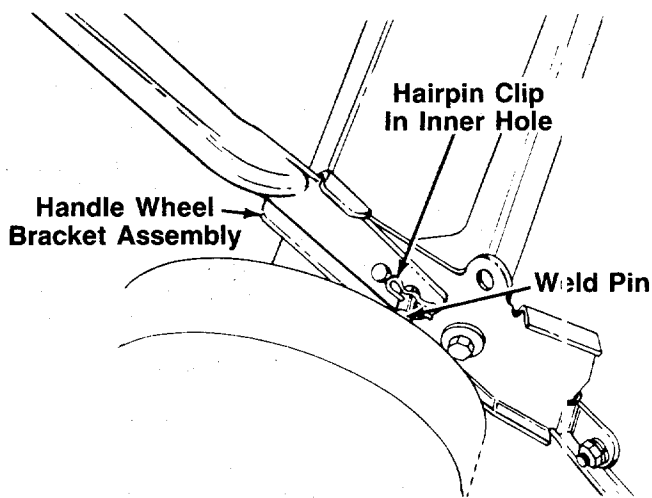

FIGURE 1.

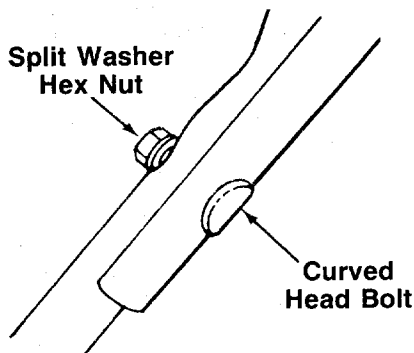

FIGURE 2.

UNPACKING

1. Remove the lawn mower from the carton by opening the top flaps and lifting the unit out. Be careful of the staples. Make certain all parts and literature have been removed from the carton before the carton is discarded.
2. Disconnect and ground the spark plug wire by hooking it into the "V" slot on the engine. Check beneath the deck for any cardboard packaging. Remove if present.
3. Stretch out all control cables and place on the floor. Be careful not to bend or kink the cables at any time during assembly.
4. Remove page four from this manual and lay the contents of the hardware pack on the illustration for identification.

ATTACHING THE LOWER HANDLE (Hardware A)

1. For shipping purposes your mower is set with the wheels in the lowest cutting height position. Raise the mower to the highest setting for assembly of lower handle.
2. Attach the lower handle by placing the bottom holes in the lower handle over the weld pins on the handle wheel bracket assemblies on the rear of the deck. Make certain the instruction label on the lower handle can be read from the operating position.
3. Using a pair of pliers, squeeze on leg of the lower handle against the handle wheel bracket assembly. Insert the hairpin clip into the **inner** hole on the weld pin. See figure 1. Repeat on other side.

ATTACHING THE UPPER HANDLE (Hardware B)

1. Place the upper handle in position over the lower handle. The label on the throttle control housing and the control lever must be facing up.
2. Secure the left hand side of upper handle using the curved head bolt, split washer and hex nut as shown in figure 2.

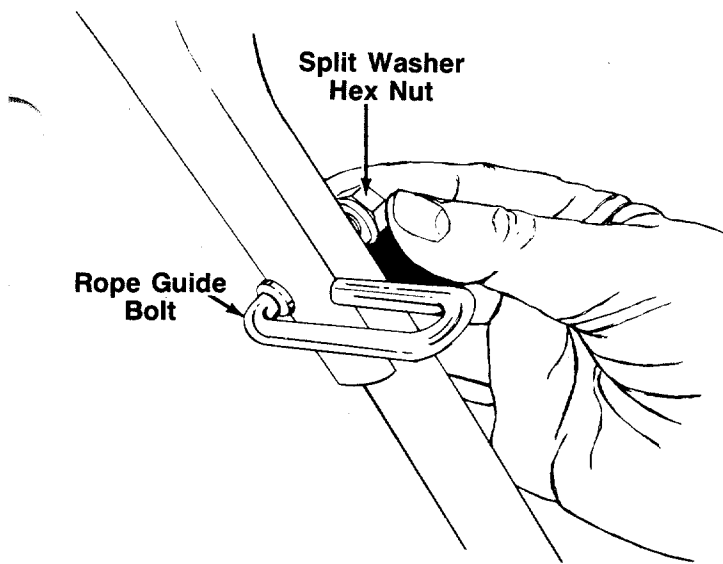

FIGURE 3.

3. Insert the rope guide bolt through the right hand side of upper and lower handle. See figure 3. Secure with split washer and hex nut, finger tight only.

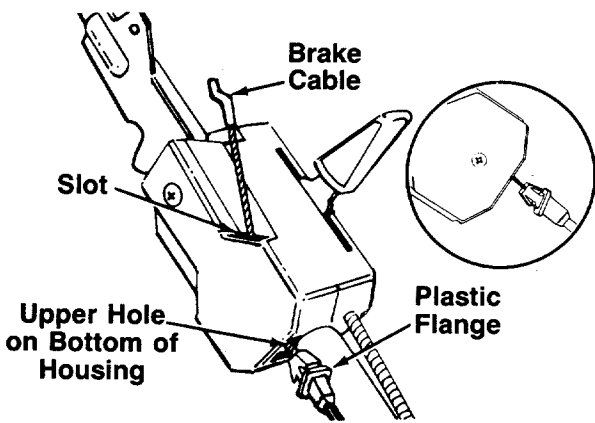

FIGURE 4.

ATTACHING THE BRAKE CABLE

1. The brake cable is attached to the engine, and has a "Z" fitting on the loose end. Route the brake cable below the lower handle. Place end of cable into the upper hole on the bottom of the control housing, and through the slot as shown. The angle of the plastic flange must be positioned downward as shown in figure 4. Be careful not to bend or kink the cable at any time.
2. Push the plastic fitting until it locks into the control housing.



Brake cable must be assembled as shown for proper blade brake operation.

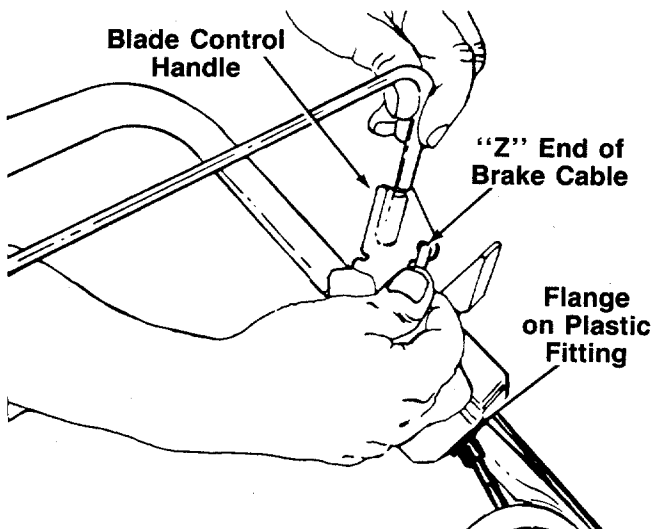

FIGURE 5.

3. Hook the "Z" end of the brake cable into the hole in the blade control handle from the inside to the outside as shown in figure 5.

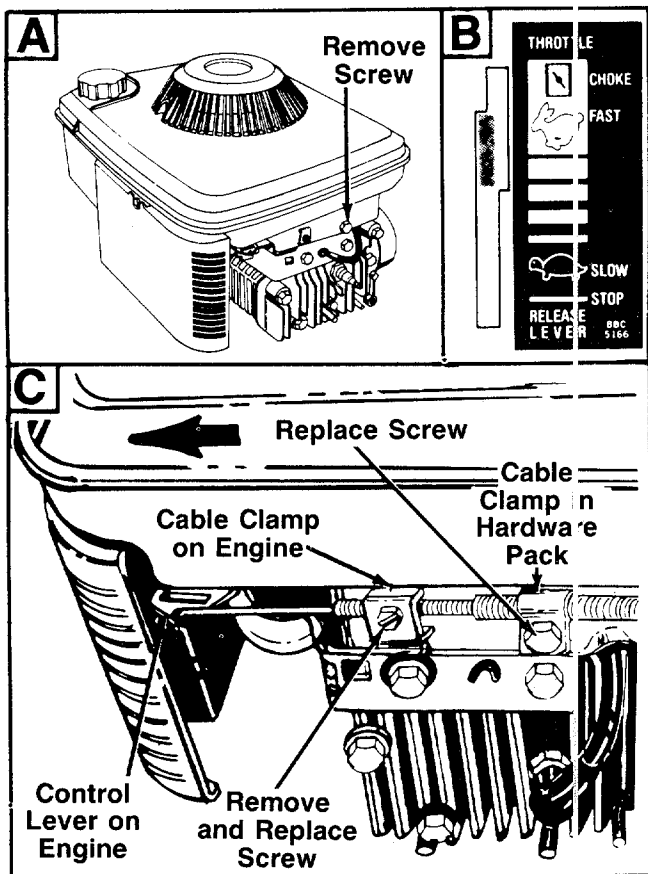

FIGURE 6.

ATTACHING THE THROTTLE CABLE (Hardware D)

1. Using a 7/16" wrench, remove the screw on the engine shown in figure 6A.
2. Move throttle control lever until it stops in FAST position (do not push all the way forward to CHOKE position). See figure 6B.
3. The throttle control cable is attached to the upper handle. Route the throttle control cable under the lower handle, inside the handle mounting bracket and through the catcher panel opening (Model 192 only). Hook the "Z" end of the throttle control cable into the hole in the control lever on the engine. See figure 6C.
4. Using a 5/16" wrench or nutdriver, remove the screw on the cable clamp shown in figure 6C. Slip the control casing under the clamp. Replace the screw (casing should be above the screw), but do not tighten screw (cable must still move freely beneath the clamp).
5. Slide the control lever on the engine as far toward the outside of the engine as it will go easily (just until resistance is felt) as shown in figure 6C. (Do not force it into the extreme outside position, which is the CHOKE position.) Tighten the screw to secure the throttle control cable in this position.
6. Loosen the screw on the clamp on the side of the engine. Slip the cable casing under the clamp to secure the cable **away from the muffler**. Be careful not to bend or kink the cable. Tighten the screw.
7. Secure cable casing to the front of engine with cable clamp provided in hardware pack and screw removed from engine in step 1. Do not overtighten.

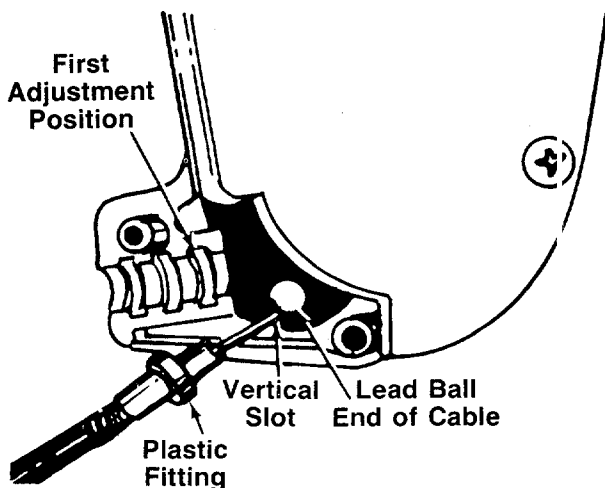

FIGURE 7.

ATTACHING THE DRIVE CLUTCH CONTROL CABLE (Hardware C)

The drive clutch control cable is attached to the deck. Attach the cable to the lever in the clutch control housing, located in the middle of the upper handle, as follows.

1. Place the lead ball end of the cable into the fitting provided in the end of the clutch control lever. Slip the braided wire into the vertical slot as shown in figure 7.

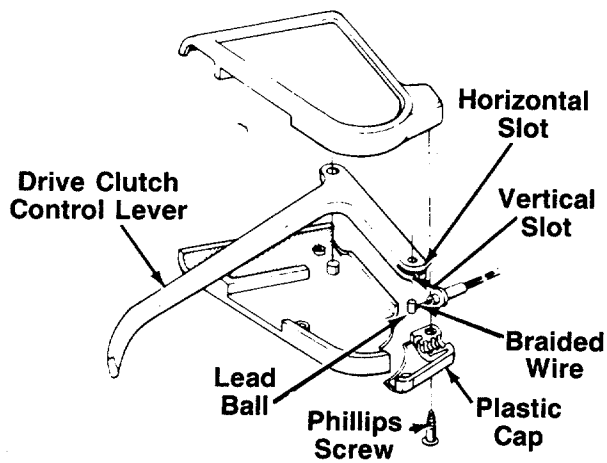

FIGURE 8.

2. Slide the braided wire around in the horizontal slot. See figure 8.
3. Place the plastic fitting on the control cable into the first adjustment position in the clutch control housing. See figure 7.
4. Secure the plastic cap to the clutch control housing using the two Phillips head screws. See figure 8.



WARNING

Drive clutch adjustment must be checked before the unit is operated, as described in the operation section.

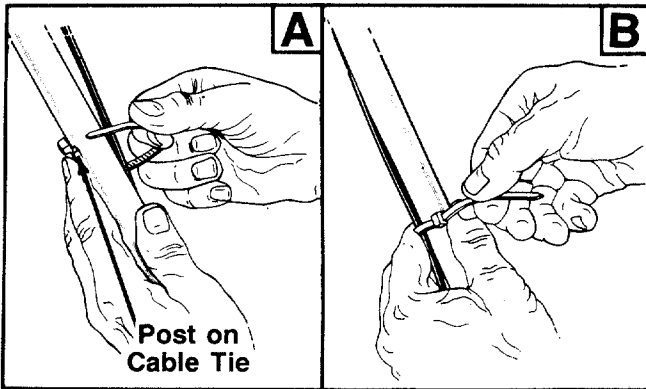

FIGURE 9.

SECURING THE CABLES (Hardware E)

Secure all control cables to the left side of the handle as follows.

- A. Insert posts on cable ties into holes provided on the lower handle, one near the top and one near the bottom of lower handle. The holes may be on either the inside or outside of the handle. See figure 9A.
- B. Secure the cables with the cable ties. See figure 9B.
- C. Trim excess ends of cable ties.

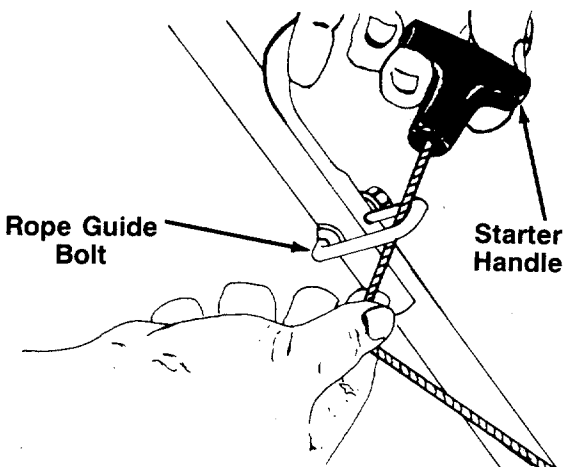

FIGURE 10.

ATTACHING THE STARTER ROPE

1. The starter rope is inside the top of the engine. On Model 192, the starter rope may be already attached to the rope guide at the catcher panel. Additional rope may be wound around the starter handle. If so, unwind the rope from the handle.
2. With the spark plug wire disconnected and grounded, depress the blade control handle and pull the rope out of the engine.
3. Slip the starter rope into the rope guide bolt as shown in figure 10.
4. Tighten the hex nut on the rope guide bolt securely.

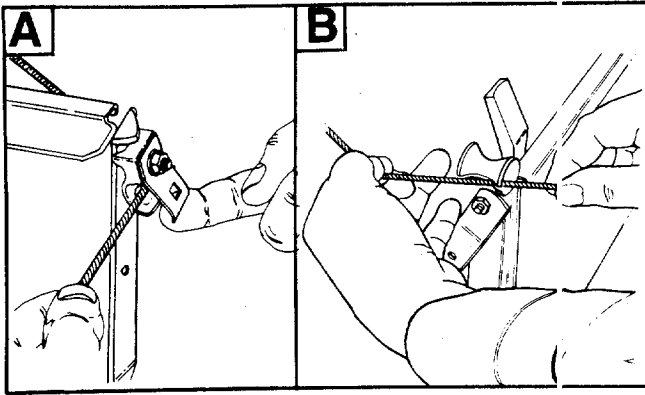

FIGURE 11.

5. **Model 192 Only:** If not already assembled, slip the starter rope under the rope guide clip or into the rope guide as shown in figure 11A or 11B.

→ IMPORTANT

If your unit is equipped with both a side chute deflector and top discharge chute and grass bag, follow the instructions for top discharge mowers. After assembly is completed, it can then easily be converted to a side discharge mower.

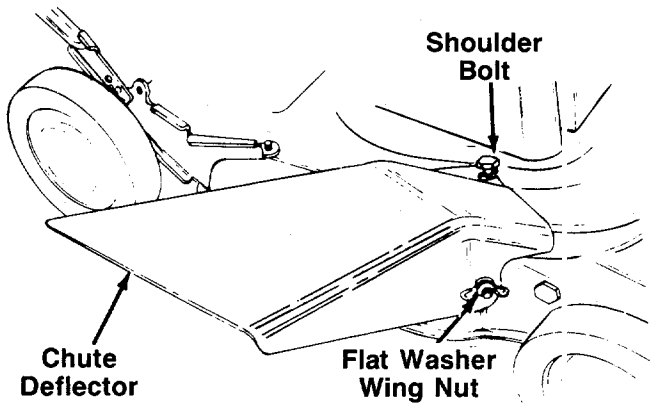

FIGURE 12.

SIDE DISCHARGE MOWERS ONLY (Model 182) (Hardware G)

This section is for side discharge models only. If your mower is a top discharge model (with grass bag), proceed to the next section.

1. Attach the chute deflector by first placing it over the rear bolt in the side of the deck, then over the front bolt and sliding it into position, with shoulder bolt on deck in notch on deflector.
2. Secure the front of the deflector to the bolt protruding from the deck with one flat washer and wing nut. See figure 12.

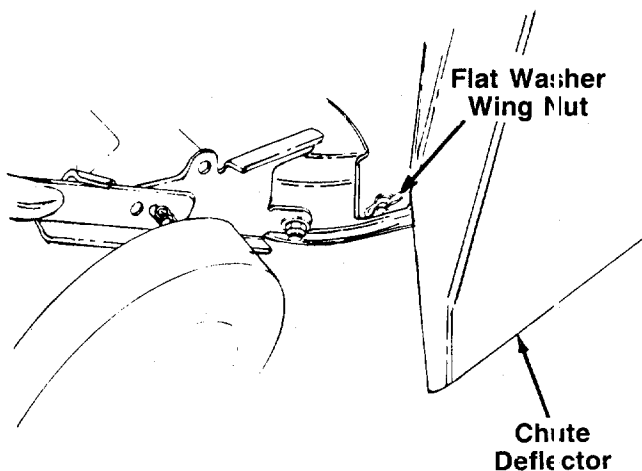

FIGURE 13.

3. Secure the back of the deflector in the same manner. See figure 13.



WARNING

Never operate your unit without either the side chute deflector or entire top discharge chute and catcher panel assembly (optional equipment) in place.

→ NOTE

A grass catcher kit is available which will convert your mower from side to top discharge. Order model number 190-067-000.

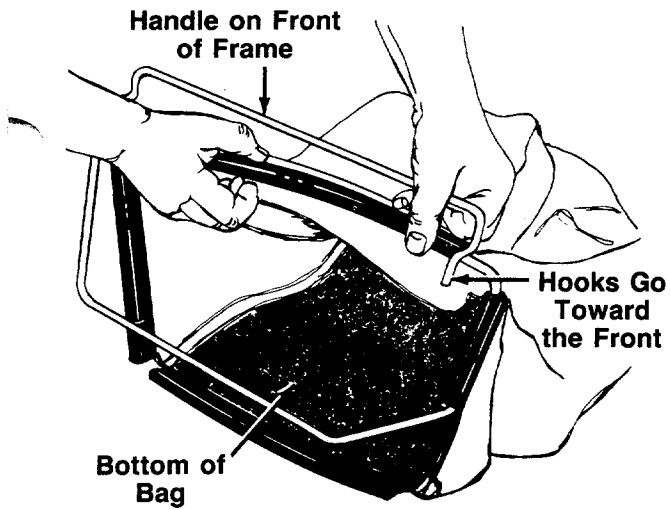

FIGURE 14.

**TOP DISCHARGE MOWERS ONLY
(Model 192)**

Grass Catcher Assembly

1. Place bag over frame (black plastic side is the bottom of bag). Handle on frame goes to the top of bag. Hooks go toward the front. See figure 14.
2. Secure bag to frame by slipping plastic channels on bag over frame. See figure 14.

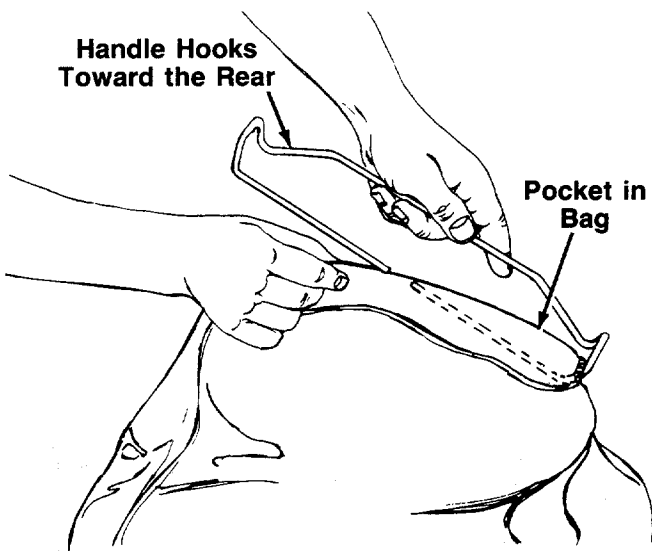

FIGURE 15.

3. Attach the rear handle to bag by inserting one side of handle into pocket on the rear of the bag. The handle should hook toward the rear of the bag as shown in figure 15. Thread all the material onto one side, then slide it over onto the other side. See figure 15.

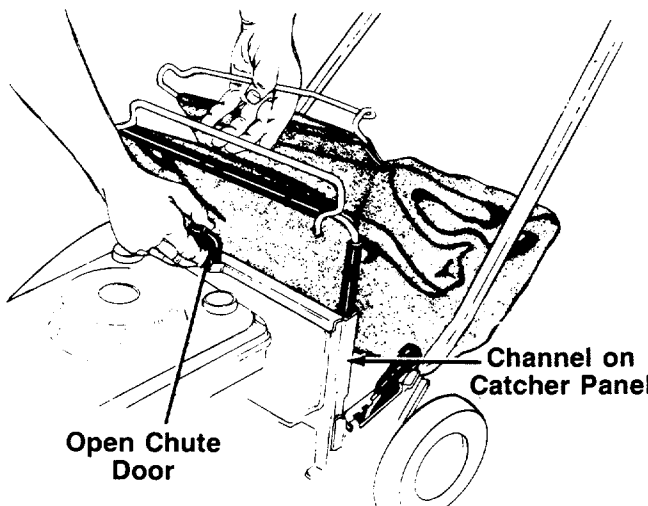

FIGURE 16.

To Attach Bag To Mower



WARNING

DO NOT operate the mower with the chute door open unless the complete grass catcher is properly mounted on the mower.

1. Hold the chute door on the catcher panel open as shown in figure 16.
2. Slide the frame of the grass catcher down into the channels on the catcher panel. The hooks on the frame go over the catcher panel.

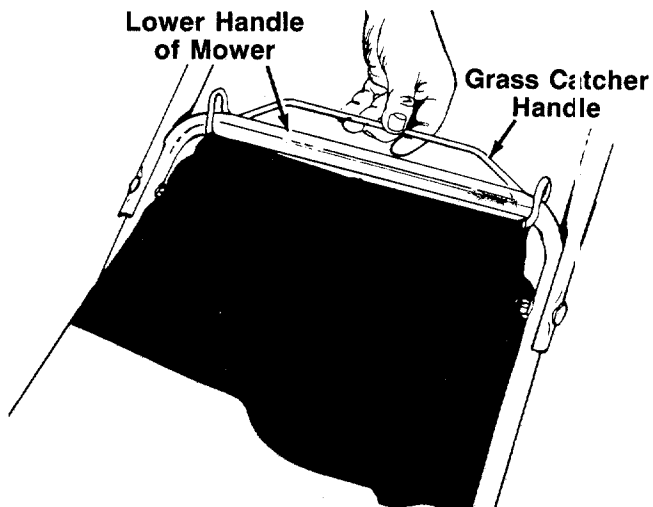

FIGURE 17.

3. Hook the handle on the rear of the grass catcher over the lower handle of the mower. See figure 17.

To remove the grass catcher, unhook the rear handle and lift the grass catcher straight up.

To convert your mower back to a side discharge unit, remove only the grass bag and top discharge chute, and assemble the side chute deflector. It is not necessary to remove the catcher panel and brackets.



WARNING

Never operate your unit without either the side chute deflector or entire top discharge chute and catcher panel assembly in place.

FINAL ASSEMBLY OF MOWER (Hardware F)

1. If plastic plug is not already assembled, insert plastic plug into hole in the top rear of the deck by slipping one end of plug into hole, then pressing down on the other end of plug. Use a soft hammer if necessary.
2. Attach hub caps (optional) to the front wheels by lining up the four tabs on the hub caps with the four holes in the wheels. Push to lock in position.
3. Make certain all nuts and bolts are tightened securely.

CONTROLS

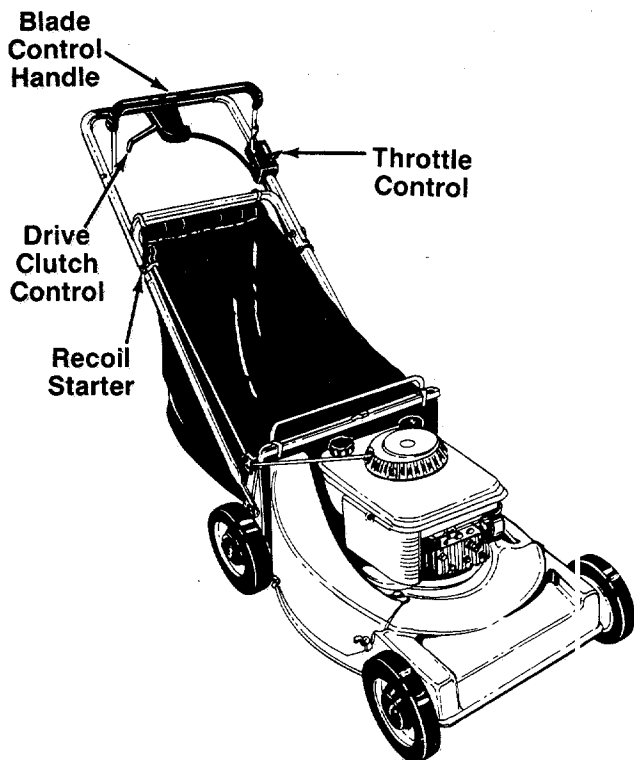

FIGURE 18.—Model 192 Shown

BLADE CONTROL HANDLE

WARNING

THIS CONTROL MECHANISM IS A SAFETY DEVICE NEVER ATTEMPT TO BYPASS ITS OPERATIONS

The blade control handle is located on the upper handle of the mower. See figure 18. The blade control handle must be depressed in order to operate the unit. Release the blade control handle to stop the engine and blade.



WARNING

The blade will be rotating whenever the engine is running.

THROTTLE CONTROL

The throttle control is located on the left side of the upper handle. It is used to regulate the engine speed. The engine should be started with the engine in the CHOKE position.



The throttle control cannot be used to stop the engine.

RECOIL STARTER

The recoil starter handle is attached to the handle. See figure 18. Stand behind the unit in the operating position to start the unit.

DRIVE CLUTCH CONTROL

Squeezing the drive clutch control engages the drive mechanism to the rear wheels. Releasing the clutch control stops the rear wheels from driving. Release the drive clutch control to slow down when negotiating an obstacle, making a turn or stopping. See figure 18.

OPERATION



FIGURE 19.

Keep hands and feet away from the chute area on cutting deck. See figure 19.

NOTE

For shipping purposes your mower is set with the wheels in a low cutting height position. For best results raise the cutting position until it is determined which height is best for your lawn. See cutting height adjustment section.

GAS AND OIL FILL-UP

Service the engine with gasoline and oil as instructed in the separate engine manual packed with your mower. **Read instructions carefully.**



Never fill fuel tank indoors, with engine running or until the engine has been allowed to cool for at least two minutes after running.

BEFORE STARTING

1. Before each use, check for proper drive clutch operation by performing the following before starting the engine:

With the drive clutch control released, push mower forward. It should move freely. **Pull mower backward. It should move freely.**

If it does not and the rear wheels tend to lock up, the clutch may not be releasing completely. Do not start the engine until corrections have been made. Check the control cable for severe bend, kinks and binding, or grass build-up in the pulley groove. Correct and adjust as required.

2. Attach spark plug wire to spark plug.
3. The fuel shut-off valve is located beneath the fuel tank. On Model 192, an access hole is provided in the catcher panel. The fuel shut-off valve should be in the open position. See figure 19. Open fuel shut-off valve using a wrench if it is closed. See figure 20.

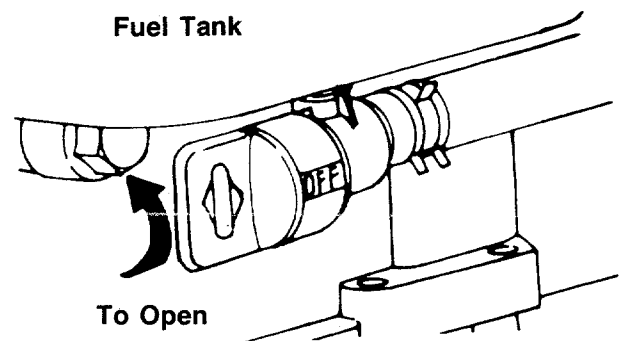

FIGURE 20.

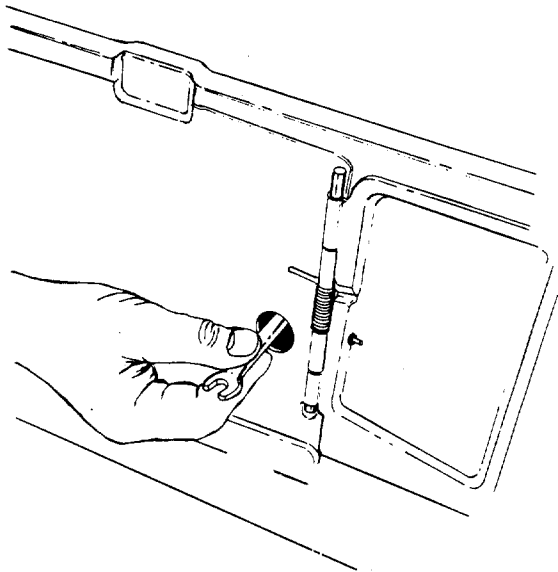

FIGURE 21.—Model 192 Only

TO START ENGINE AND ENGAGE BLADE



When starting the unit for the first time, face the mower against a solid object such as a wall, fence, etc. Start the unit, and if it shows any signs of motion with the drive clutch control disengaged, shut the engine off immediately. Check the position of the drive clutch control cable. The plastic fitting must be assembled in the first adjustment position inside the housing, all the way to the right, as shown in figure 7.

1. Move the throttle control lever to CHOKE position.



A warm engine may not require choking.

2. Standing behind the unit, depress the blade control handle and hold it against the upper handle.
3. Grasp the recoil starter handle and pull back rapidly, extending rope fully. Return it slowly to the rope guide bolt.
4. After engine starts, move throttle control to FAST or desired engine speed.



If any problems are encountered, refer to the Trouble Shooting Chart on page 24.



Never operate your unit without either the side chute deflector or entire top discharge chute and catcher panel assembly in place.

TO STOP ENGINE AND BLADE

1. Release the blade control handle to stop the engine and blade.



The blade continues to rotate for a few seconds after the engine is shut off.

2. Disconnect the spark plug wire and ground it against the engine to prevent accidental starting while equipment is unattended.

USING YOUR ROTARY MOWER



DO NOT operate mower Model 192 with the chute door open unless the complete grass catcher is properly mounted on the mower.

Be sure that lawn is clear of stones, sticks, wire, or other objects which could damage lawn mower or engine. Such objects could be accidentally thrown by the mower in any direction and cause serious personal injury to the operator and others.

Operate a new engine at intermediate speeds and light load for the first few hours as you would a new automotive engine.

For the best results, do not cut wet grass because it tends to stick to the underside of the mower, preventing proper discharge of grass clippings, and could cause you to slip and fall. New grass, thick grass or wet grass may require a narrower cut. Blade speed should be adjusted to the condition of the lawn.

When using the side discharge mower, the best mowing pattern is one that allows the clippings to discharge towards the uncut part of the lawn. This permits re-cutting of the clippings to further pulverize them. When cutting high weeds, discharge towards cut portion, then recut at right angles to first direction.

For best results, cut off one-third or less of the total length of the grass. Lawn should be cut in the fall as long as there is growth.

This mower is designed to be operated at full throttle to give you the best cut and do the most effective job of bagging the cut grass.

→ IMPORTANT

If you strike a foreign object, stop the engine. Remove wire from spark plug, thoroughly inspect the mower for any damage, and repair the damage before restarting and operating the mower. Extensive vibration of the mower during operation is an indication of damage. The unit should be promptly inspected and repaired.

ADJUSTMENTS



WARNING

Do not at any time make any adjustment to lawn mower without first stopping engine and disconnecting spark plug wire.

DRIVE CLUTCH CONTROL ADJUSTMENT

If the unit does not self-propel with the drive clutch control engaged, remove the plastic cap from beneath the drive clutch control housing. Move the plastic fitting on the control cable to the next adjustment position on the left. Reassemble the plastic cap and retest. See figure 23.

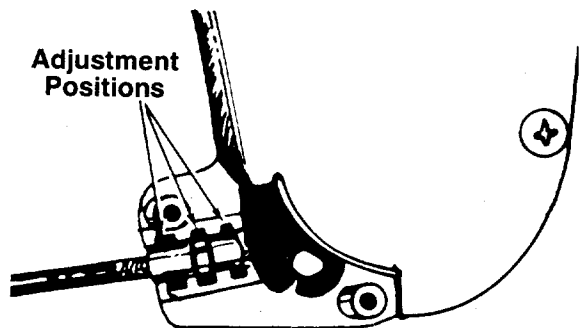

FIGURE 22.

CUTTING HEIGHT ADJUSTMENT

The height adjustment handle is located on the left side of the deck. The handle may be placed in one of nine cutting height positions. Push the handle to the left and then either forward to lower the cutting height or backward to raise the cutting height. See figure 23.

For rough or uneven lawns, move the height adjustment handle to a position which will give a higher cutting height.

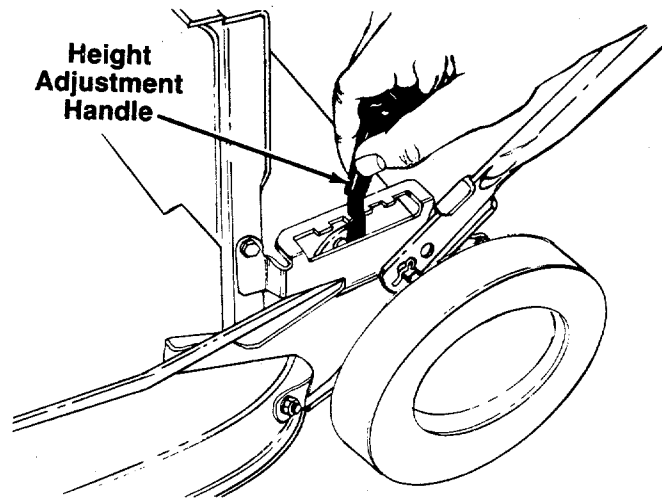

FIGURE 23.

THROTTLE

The throttle control wire assembly can be adjusted if necessary. Loosen the screw on the cable clamp closest to the control lever on engine. Adjust as instructed in step 5 of "Attaching the Throttle Control Cable" in Assembly Instructions.

CARBURETOR ADJUSTMENTS



WARNING

If any adjustments are made to the engine while the engine is running (e.g. carburetor), keep clear of all moving parts. Be careful of heated surfaces and muffler.

Minor carburetor adjustment may be required to compensate for differences in fuel, temperature, altitude and load. Refer to the separate engine manual packed with your mower for carburetor adjustment information.

→ NOTE

A dirty air cleaner will cause an engine to run rough. Be certain air cleaner is clean and attached to the carburetor before adjusting carburetor. Refer to the separate engine manual.

LUBRICATION



WARNING

Always stop engine and disconnect spark plug wire before cleaning, lubricating or doing any kind of work on lawn mower.

Blade Control—Lubricate the pivot points on the blade control handle and the brake cable at least once a season with light oil. See figure 24. The blade control must operate freely in both directions.

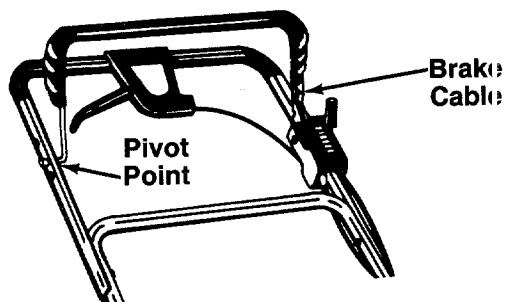

FIGURE 24.

Discharge Chute Door Mechanism (Model 192)—The torsion spring and pivot point should be lubricated periodically with light oil to prevent any rust or binding. Door must work freely.

Wheels—Mower may be provided with ball bearing wheels. Lubricate at least once a season with light oil. Also, if the wheels are removed for any reason, lubricate the surface of the axle bolt and the inner surface of the wheel with light oil. A 4 oz. plastic bottle of light oil lubricant is available. Order part number 737-0170. Engine oil may also be used.

Engine—Follow engine manual for lubrication instructions.

Throttle—Periodically lubricate throttle control lever and throttle wire assembly with a few drops of light oil for ease of operation.

Transmission—The transmission is pre-lubricated and sealed at the factory. It does not require checking. If disassembled for any reason, fill with 2 ounces of Alvania grease, part number 737-0168.

MAINTENANCE

NOTE

When tipping the unit, empty the fuel tank and keep engine spark plug side up.

TROUBLE SHOOTING

Refer to page 24 of this manual for trouble shooting information.

CUTTING BLADE

A. Removal for Sharpening or Replacement



Be sure to disconnect and ground the spark plug wire before working on the cutting blade to prevent accidental engine starting. Protect hands by using heavy gloves or a rag to grasp the cutting blade.

Remove the large bolt and Belleville washer which holds the blade and adapter to the engine crankshaft. Remove the blade and adapter from the crankshaft.

If the blade or blade adapter needs replacing, remove the two small bolts, lock washers and nuts which hold the blade to the adapter.



Periodically inspect the blade adapter for cracks, especially if you strike a foreign object. Replace when necessary.

B. Sharpening

Remove the cutting blade by following the directions of the preceding section.

When sharpening the blade, follow the original angle of grind as a guide. It is **extremely important** that each cutting edge receives an equal amount of grinding to prevent an unbalanced blade. An unbalanced blade will cause excessive vibration when rotating at high speeds, may cause damage to the mower and could break, causing personal injury.

It is recommended that the blade always be removed from the adapter for the best test of balance. The blade can be tested by balancing it on a round shaft screwdriver. Remove metal from the heavy side until it balances evenly.

C. Reassembly

Before reassembling the blade and the blade adapter to the unit, lubricate the engine crankshaft and the inner surface of the blade adapter with light oil. Lubricating the bolt holes, bolts and inner surface of the nuts with light oil is also recommended. A 4 oz. plastic bottle of light oil lubricant is available. Order part number 737-0170. Engine oil may also be used.

When replacing the blade, be sure to install the blade with the side of the blade marked "Bottom" (or with part number) facing the ground when the mower is in the operating position.

Blade Mounting Torque

3/8" Dia. Bolt 375 in. lb. min., 450 in. lb. max.
5/16" Dia. Bolt 150 in. lb. min., 250 in. lb. max.

To insure safe operation of your unit, all nuts and bolts must be checked periodically for correct tightness.

DECK

The underside of mower deck should be cleaned after each period of use as grass clippings, leaves, dirt and other matter will accumulate. This accumulation of grass clippings, etc., is undesirable as it will invite rust and corrosion and may cause an uneven discharge of grass clippings at the next cutting.

The deck may be cleaned by tilting the mower forward or on its side and scraping clean with a suitable tool or by washing with a stream of water from a garden hose.

NOTE

Do not direct the stream of water at a hot engine as damage to the engine may result.

ENGINE

Refer to the separate engine manual for all engine maintenance instructions.

Maintain **engine oil** as instructed in the separate engine manual packed with your unit. Read and follow instructions carefully.

Service **air cleaner** every 25 hours under normal conditions. Clean every few hours under extremely dusty conditions. Poor engine performance and flooding usually indicates that the air cleaner should be serviced. To service the air cleaner, refer to the separate engine manual packed with your unit.

The **spark plug** should be cleaned and the gap reset once a season. Spark plug replacement is recommended at the start of each mowing season; check engine manual for correct plug type and gap specifications.

BELT REMOVAL AND REPLACEMENT

1. Disconnect the spark plug wire and ground it against the engine.
2. Drain the fuel tank or place a piece of plastic beneath the cap to prevent gasoline leakage.
3. Remove the transmission belt guard as follows. See figure 25.
 - A. On Model 192, remove the three bolts on the left side of the catcher panel to loosen the catcher panel. A $3/8$ " and $7/16$ " wrench are required.
 - B. Remove two bolts which secure the transmission belt guard, using a $3/8$ " wrench.
 - C. Lift up on left side of catcher panel and remove the transmission belt guard.
4. Tip the mower on its side, and block securely.

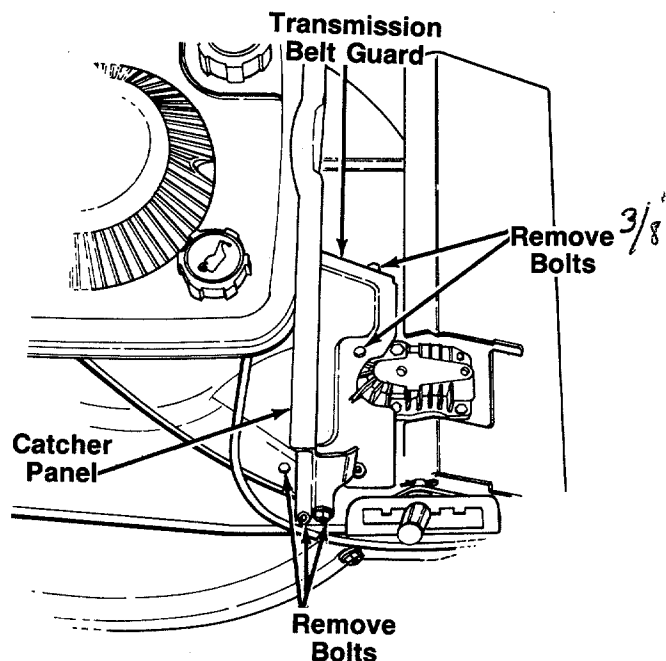

FIGURE 25.

5. Remove the center bolt which secures the blade to the crankshaft. See figure 26. Roll the belt off the pulley. Remove the blade (and blade adapter with pulley).
6. Remove the inside belt guard by removing two self-tapping screws. A $3/8$ " wrench is required. See figure 26.

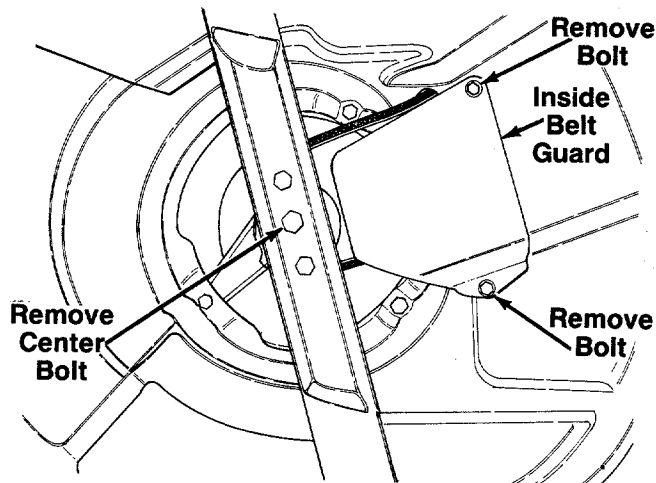

FIGURE 26.

7. Remove the belt from between the idler pulley and the belt guard on the idler pulley bracket. Refer to figure 28.
8. Remove the belt from the transmission pulley.

9. Assemble the new belt as follows.
- Push the idler pulley up out of the way as shown in figure 27.
 - Slide the belt in from the rear of the deck, and place it around the transmission pulley. See figure 27.
 - Release the idler pulley so it falls down into position. Slide the belt in between the idler pulley and the belt guard on the idler pulley bracket as shown in figure 28.
 - Grease the crankshaft. Place belt around the pulley on the blade adapter, and reassemble the blade. Reassemble the inside belt guard.
 - Reassemble the transmission belt guard, following instructions in step 3 in reverse order.

NOTE

When reassembling the transmission belt guard, be certain it is approximately 1/8" away from the belt. Make certain to tighten all nuts and bolts securely. If plastic was placed under the gas cap, be certain to remove it.

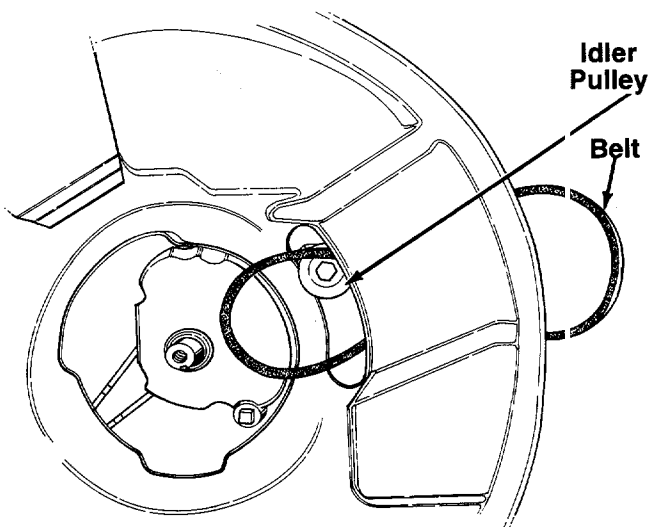

FIGURE 27.

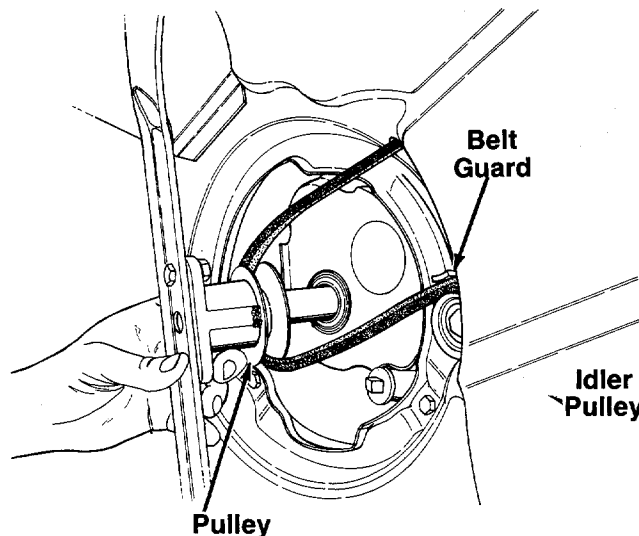

FIGURE 28.

OFF-SEASON STORAGE

The following steps should be taken to prepare lawn mower for storage.

- Clean and lubricate mower thoroughly as described in the lubrication instructions.
- Refer to engine manual for correct engine storage instructions.
- Coat mower's cutting blade with chassis grease to prevent rusting.
- Store mower in a dry, clean area.

NOTE

When storing any type of power equipment in an unventilated or metal storage shed, care should be taken to rustproof the equipment. Using a light oil or silicone, coat the equipment, especially cables and all moving parts.

→ NOTE

The use of any accessory on this Rotary Mower other than those manufactured by the mower manufacturer is **not** recommended.

GRASS CATCHER Model 067 is available as replacement equipment for the mower Model 192 shown in this manual.



1. DO NOT operate the mower with the chute door open unless the complete grass catcher is properly mounted on the mower.
2. DO NOT operate the mower without the protective shield on the rear of the deck in place.

→ NOTE

Under normal usage bag material is subject to wear and should be checked periodically. Be sure any replacement bag complies with the mower manufacturer's recommendations.

For replacement bags, use only factory authorized replacement bag No. 764-0212.

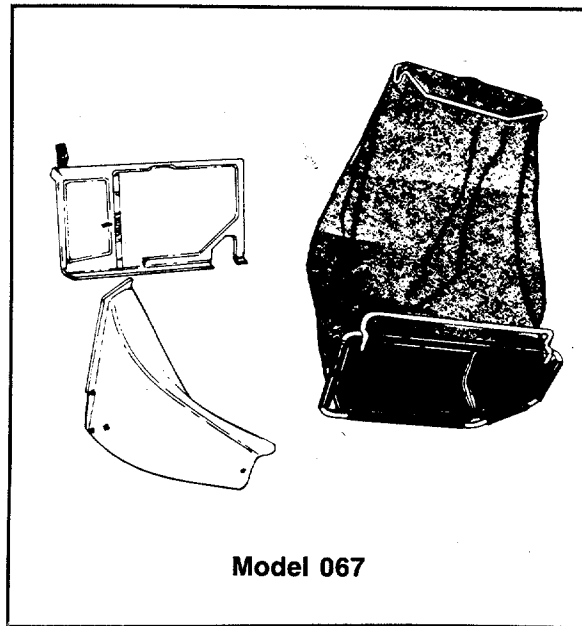

Model 067

For units not equipped with the above, top discharge grass bag assembly Model 190-067-000 is available as optional equipment.

067

Models 182 and 192

747-0563
LONGER
TO CORRECT
SHORT BAGS
COMING OFF
BACK PANEL

LATER PRODUCTION

EARLY
PROD

UNITS HARD TO PULL BACKWARDS
REPLACE BEARING CUP WITH NEW
PART No. 17072

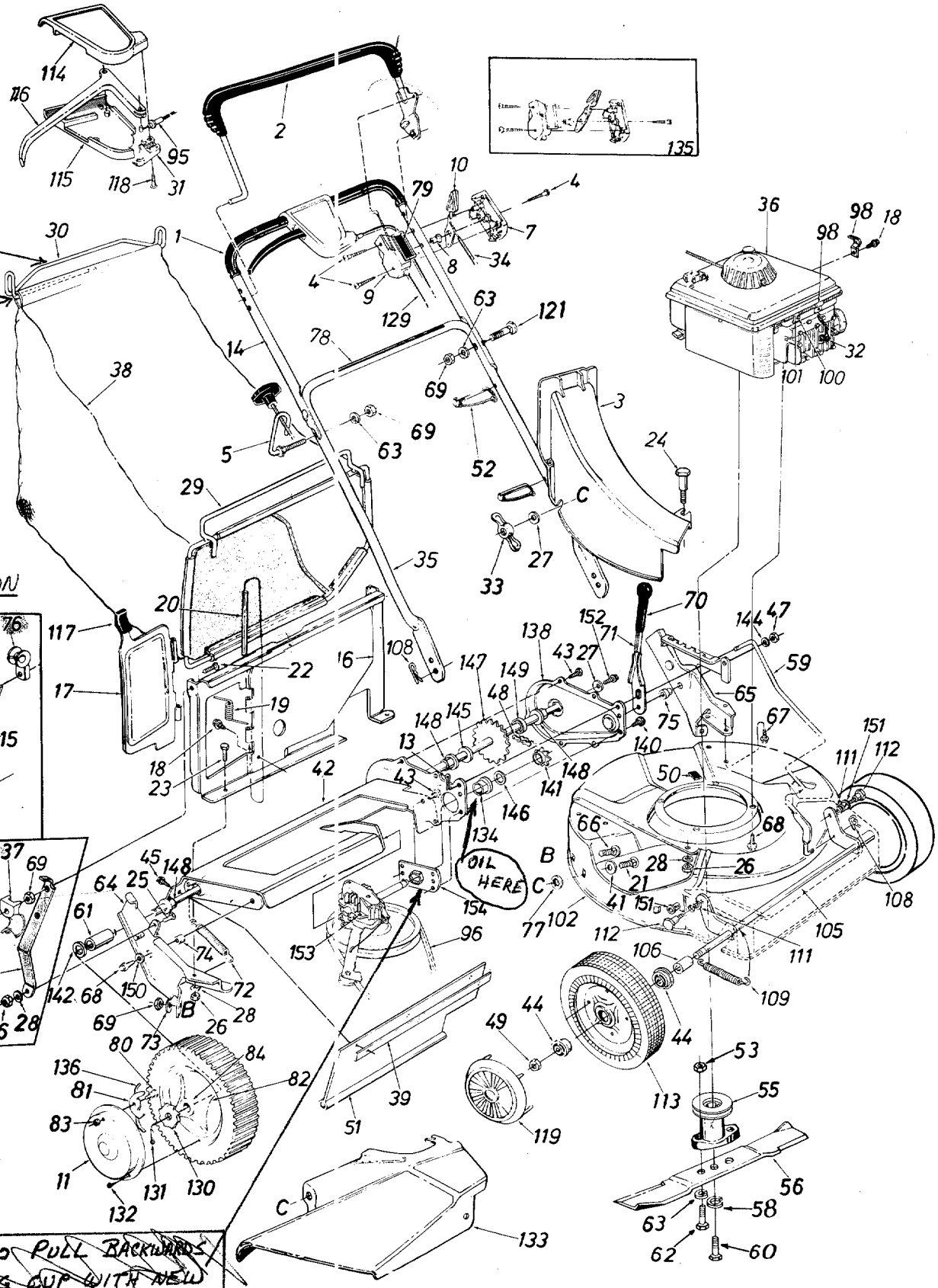

Models 182 and 192

PARTS LIST FOR MODELS 182 AND 192 21" ROTARY MOWERS

REF. NO.	PART NO.	COLOR CODE	DESCRIPTION	NEW PART	REF. NO.	PART NO.	COLOR CODE	DESCRIPTION	NEW PART
1	718-0145		Grip		55	756-0511		Blade Adapter w/Pulley	N
2	731-0609		Control Handle Ass'y.—L.H.		56	742-0307		21" Blade	N
3	731-0733		Top Discharge Chute Ass'y.		58	736-0356		Bell-Wash. .39" I.D. x 1.380" O.D.	
4	710-0796		Truss Mach. Scr. #12 x 1.50" Lg.		59	747-0510		Height Adj. Rod 19.42" Lg.	
5	710-0842		Rope Guide Bolt		60	710-0331		Hex Bolt 3/8-24 x 2.25" Lg. (Grade 5)	
7	731-0817		Control Panel Half		61	748-0190		Spacer .513" I.D. x .703" O.D. x .69" Lg.	
8	731-0524		Control Disc Pin		62	710-0888		Hex Bolt 5/16-24 x 1.00" Lg. (Grade 5)	
9	731-0816		Clutch Panel Half		63	736-0119		L-Wash. 5/16" I.D.*	
10	731-0528		Throttle Control Lever		64	16136		R.H. Handle Wheel Brkt. Ass'y.	
11	10647		Hub Cap (Rear)		65	16137		L.H. Handle Wheel Brkt. Ass'y.	
13	714-0507		Cotter Pin 3/32" Dia. x .75"*		66	710-0260		Carriage Bolt 5/16-18 x .62"*	
14	749-0437		Upper Handle—Chrome		67	710-0603		Hex Wash. Hd. B-Tap Scr. 5/16-18	
15	16541		Panel Support Brkt.†		68	710-0654		Hex Wash. Hd. TT-Tap Scr. 3/8-16	
	16129		Panel Support Brkt.†		69	712-0267		Hex Nut 5/16-18 Thd.*	
16	16140		Top Catcher Panel†		70	720-0143		Grip	
17	16145		Top Door†		71	732-0473		Height Adj. Lever	
18	710-0429		Hex B-Tap Scr. #10 x .38"†		72	732-0481		Extension Spring .50" O.D. x 3.80" Lg.	
19	732-0483		Torsion Spring†		73	736-0242		Bell-Wash. 5/16" I.D.	
20	747-0514		Pivot Pin†		74	750-0526		Spacer .385" I.D. x .502" O.D. x .270" Lg.	
21	710-0134		Carriage Bolt 1/4-20 x .62"*		75	750-0624		Shld. Spacer .500" Dia. x .100	
22	710-0225		Truss Mach. Scr. 1/4-20 x 3/4" Lg.†		76	719-0279		Rope Guide†	N
23	710-0289		Hex Bolt 1/4-20 x .50" Lg.*		77	726-0233		Bolt Retainer 1/4 x .50" O.D.	
4	738-0704		Shoulder Bolt .312 Dia. x .18 Lg. Special		78	777-5776		Instruction Label	
25	710-0258		Hex Bolt 1/4-20 x .62" Lg.*		79	777-5774		Control Label	
26	712-0287		Hex Nut 1/4-20 Thd.*		80	738-0137		Shld. Scr. .342" Dia. x .268	
27	736-0270		Bell-Wash. 1/4" I.D.		81	748-0188		Pawl	
28	736-0329		L-Wash. 1/4" I.D.*		82	734-1411		Wheel Ass'y. Comp.—Rear 8 x 1.75	
29	747-0494		Front Grass Catcher Frame†		83	712-0324		Hex Ins. L-Nut 1/4-20 Thd.	
30	747-0495		Grass Catcher Handle†		84	741-0180		Flange Ball Bearing 1/2" I.D.	
31	731-0619		S.P. Control Cover		85	746-0650		S.P. Cable x 50" Lg.	N
32	735-0639		Spark Plug Insulator		86	754-0343		"V"-Belt	N
33	712-0109		Wing Nut		87	12894		Casing Clamp	
34	746-0633		Throttle Control Wire 58"		88	710-0436		Hex B-Tap Scr. #10 x .62"	
35	749-0505		Lower Handle—Chrome		89	751-0442		Casing Clamp	N
36	—		Engine		90	17075	463	21" Deck Ass'y.	
37	751-0434		Rope Guide Half†		91	10662		Front Axle Ass'y.	
38	764-0212		21" Top Discharge Grass Bag†		92	711-0313		Sleeve .526" I.D. x .690" O.D. x .880" Lg.	
39	14835		Retaining Strip		93	714-0104		Intern. Cotter Pin 5/16" Dia.	
40	732-0528		Rope Retainer Spring Clipt		94	732-0482		Extension Spring .50" O.D. x 3.20" Lg.	
41	736-0204		Fl-Wash. .344" I.D. x .62"		95	736-0221		Intern. L-Wash. 3/8 I.D.*	
42	17055		Chain—Axle Ass'y.	N	96	738-0705		Shld. Bolt .623" Dia. x .425	
43	710-0352		Hex B-Tap Scr. 1/4" x .38" Lg.		97	734-0922		Front-Wheel Ass'y. Comp. 7 x 1.50	
44	741-0180		Flange Ball Bearing 1/2" I.D.						
45	710-0776		Hex AB-Tap Scr. 1/4 x .62"						
47	712-0296		Hex Patch L-Nut 3/8-24 Thd.						
48	713-0353		#48 Chain .500" Pitch x .30 Links						
49	712-0346		Hex L-Nut 1/2-20 Thd.						
50	731-0564		Plug						
51	731-0672		Rear Flap 3.75" x 17.30" Lg.						
52	726-0240		Cable Tie						
53	712-0123		Hex Nut 5/16-24 Thd.*						

Models 182 and 192

PARTS LIST FOR MODELS 182 AND 192 21" ROTARY MOWERS (CONTINUED)

REF. NO.	PART NO.	COLOR CODE	DESCRIPTION	NEW PART	REF. NO.	PART NO.	COLOR CODE	DESCRIPTION	NEW PART
114	731-0617		Self-Propelled Control Cover		142	736-0326		Fl-Wash. .510" I.D. x 1.0" O.D.	
115	731-0618		Self-Propelled Control Cover						
116	731-0620		Control Lever		144	736-0300		Fl-Wash. .385" I.D. x .87" O.D.	
117	720-0208		Door Gript						
118	710-0841		Fl-"C"-Sunk Hd. Tap Scr. #10 x .75" Lg.		145	736-0326		Fl-Wash. .51" I.D. x 1.0" O.D.	
119	**		Hub Cap—Plastic		146	736-0336		Fl-Wash. 3/8" I.D.	
121	710-0671		Curved Carr. Bolt 5/16-18 x 1.38" Lg.		147	738-0719	SPLINED	Rear Shaft Ass'y. 21.94" Lg.	N
					148	741-0324		Hex Flange Bearing .506" I.D. Plastic	
129	746-0477		Control Cable—43" Lg.						
130	748-0318	SPLINED	Ratchet Wheel 1.62" O.D.		149	736-0160		Fl-Wash. .531" I.D. x .930" O.D.	
131	714-0115		Cotter Pin 1/8" Dia. x 1.00" Lg.*		150	736-0179		Fl-Wash. .531" I.D. x 1.25" O.D.	
132	710-0748		Pan Hd. Tap Scr. #12 x .50" Lg.		151	741-0491		Flanged Nyliner Brg.	
133	16559	463	Side Chute Deflector Ass'y.	N	152	710-0751		Hex Bolt 1/4-20 x .62" Lg. (Grade 5)	
134	748-0249	0413	Flange Bearing						
135	753-0360		Kit—Control Housing Comp.		153	717-0417		Transmission Comp. (See Breakdown)	
136	10622		Spring—Nylon						
138	17053		Chain Cover		154	16500		Hex Bearing Cup	
140	710-0599		Hex Wash. S-Tap Scr. 1/4-20 x .50" Lg.		—	8182-000-7		Hardware Pack (182)	
141	713-0400		Sprocket—Shaft Ass'y.		—	8192-000-7		Hardware Pack (192)	

**Used with Ref. Nos. 37 and 40.

***Used with Ref. No. 76.

†Top Discharge Model 192 Only.

*For faster service obtain standard nuts, bolts and washers locally. If these items cannot be obtained locally, order by part number and size as shown on parts list.

If color or finish is important when ordering parts, use the appropriate color code shown below [i.e. (part no.)-463 for Topflite Red Finish].

Color Codes

NOTE: The engine is not under warranty by the mower manufacturer... If repairs or service is needed on the engine, please contact your nearest authorized engine service outlet. Check the "Yellow Pages" of your telephone book under "Engines—Gasoline."

Find It Fast
In The
Yellow Pages

312—White
436—Radiant Yellow
447—Patina Silver
452—Black
456—Radiant Tangerine
460—Green Flake

463—Topflite Red
480—Brilliant Green
483—Charcoal Grey
499—Beige
606—Majestic Orange
629—Silver Flake

**Optional Hub Caps

Color	Part No.
Red	731-0124
Orange	731-0254
Black	731-0354
Grey	731-0355

NOTE

This instruction manual covers various models and all specifications shown do not necessarily apply to your model. Specifications subject to change without notice or obligation.

Models 182 and 192

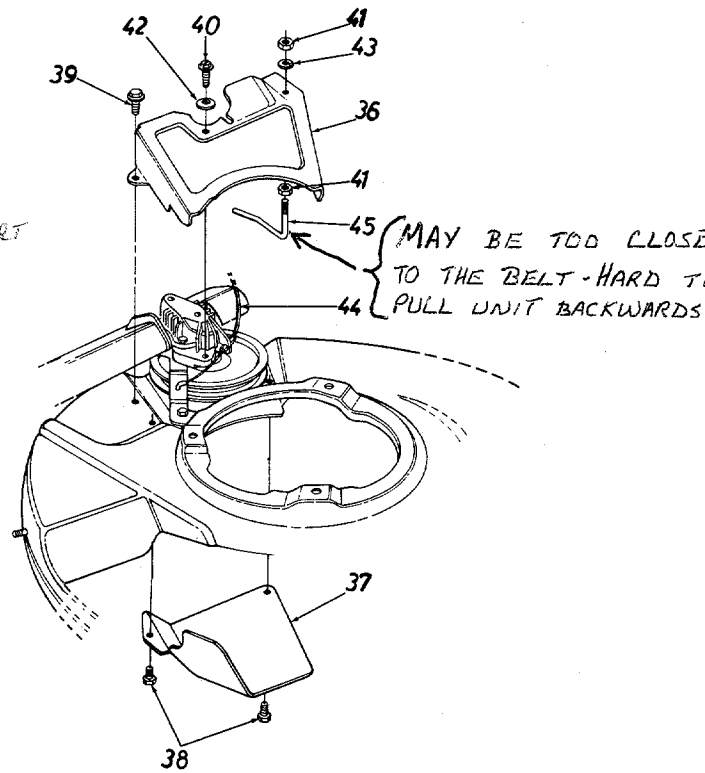
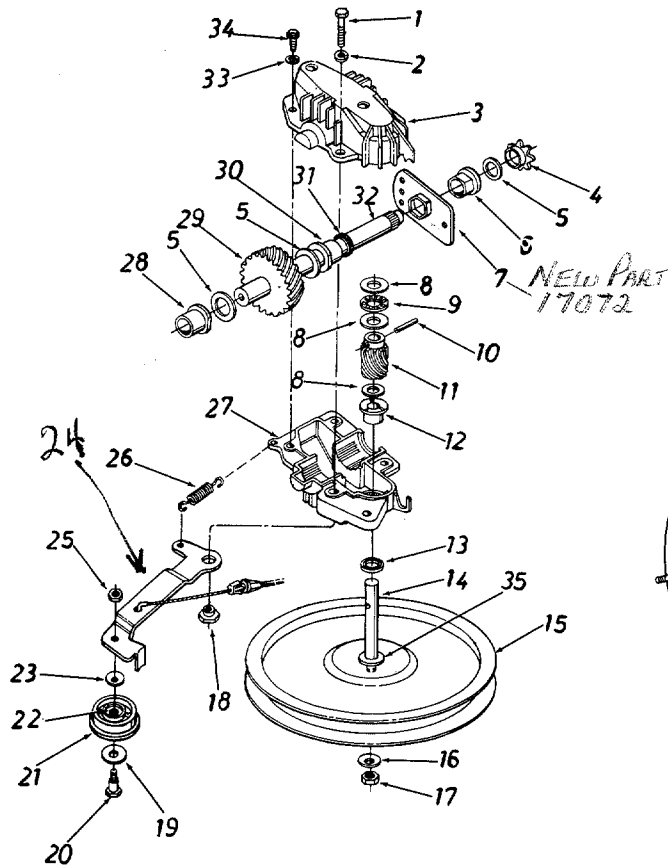

PARTS LIST FOR MODELS 182 AND 192 21" ROTARY MOWERS

REF. NO.	PART NO.	COLOR CODE	DESCRIPTION	NEW PART	REF. NO.	PART NO.	COLOR CODE	DESCRIPTION	NEW PART
1	710-0106		Hex Bolt 1/4-20 x 1.25" Lg.*		22	741-0482		Needle Brg. .375" x .31†	
2	736-0329		L-Wash. 1/4" I.D.*		23	736-0270		Bell-Wash. .265" I.D. x .75"†	
3	717-0418		Upper Hsg. Half		24	47502 17052		Idler Brk't. Ass'y.†	N
4	713-0400		#48 Sprocket 7 Tooth x 1/2 Pitch		25	712-0138		Hex Patch L-Nut 1/4-28 Thd.†	
5	736-0336		FI-Wash. 5/8" I.D. x .030		26	732-0357		Extension Spring 1.12" Lg.†	
6	741-0413		Hex Flange Brg. .631" I.D.		27	717-0419		Lower Hsg. Half	
7	16500		Hex Bearing Cup		28	741-0415		Flange Bearing .566 Dia.	
8	736-0314		Thrust Wash. .382" I.D. x .70" O.D.		29	717-0422		33 Tooth Helical Gear	
9	741-0479		Thrust Bearing .375" I.D. x .812" O.D.		30	741-0414		Flange Bearing .629 Dia.	
10	715-0152		Spring Pin Spir. 1/8" x .62" Heavy		31	721-0213		Oil Seal .625 Dia.	
11	717-0420		11 Tooth Helical Gear		32	738-0607		Gear Sprocket Shaft	
12	748-0208		Flange Bearing		33	736-0722		L-Wash. #10 I.D.	
13	721-0212		Oil Seal		34	710-0436		Hex B-Tap Scr. #10 x .62"	
14	738-0708		Pulley-Transmission Shaft		35	736-0410		Hex Washer .26" x .88"†	N
15	756-0330		FI-Pulley 5.06" O.D.†		36	17058		Transmission Belt Guard†	N
16	736-0270		Bell-Wash. .265" I.D. x .75"†		37	17064		Belt Cover†	N
17	712-0138		Hex L-Nut 1/4-28 Thd.†		38	710-0352		Hex B-Tap Scr. 1/4 x .38" Lg.†	
18	738-0440		Shld. Spacer .375" Dia. x .170"†		39	710-0599		Hex AB-Tap Scr. 1/4 x .50" Lg.†	
19	736-0344		FI-Wash. .390" I.D. x 1.0"†		40	710-0896		Hex B-Tap Scr. 1/4 x .62" Lg.	
20	738-0691		Shld. Bolt .375" Dia. x .40"†		41	712-0287		Hex Nut 1/4-20 Thd.*†	
21	756-0447		FI-Idler Plastic 1.50" Dia.†		42	736-0270		Bell-Wash. .265" I.D. x .75"†	
					43	736-0329		L-Wash. 1/4" I.D.*†	
					44	746-0650		S.P. Cable—50" Lg.†	N
					45	747-0549		S.P. Belt Guard†	N
					—	717-0417		Transmission Comp.	

†Not Part of Transmission Complete

Trouble Shooting Chart

Symptom	Possible Causes	Corrective Action
1 Engine fails to start	<p>A Blade control handle disengaged</p> <p>B Check fuel tank for fuel</p> <p>C Fuel shut-off valve closed</p> <p>D Spark plug lead wire disconnected</p> <p>E Throttle control lever not in the starting position</p> <p>F Faulty spark plug</p> <p>G Carburetor improperly adjusted, engine flooded</p> <p>H Old stale fuel</p> <p>I Engine brake engaged</p>	<p>A Engage blade control handle.</p> <p>B Fill tank if empty.</p> <p>C Open fuel shut-off valve.</p> <p>D Connect lead wire.</p> <p>E Move throttle lever to start position.</p> <p>F Clean, adjust gap or replace.†</p> <p>G Remove spark plug, dry the plug, crank engine with plug removed, and throttle in off position. Replace spark plug and lead wire and resume starting procedures.</p> <p>H Drain and refill with fresh fuel.</p> <p>I Follow starting procedure.</p>
2 Hard starting or loss of power	<p>A Spark plug wire loose</p> <p>B Carburetor improperly adjusted</p> <p>C Dirty air cleaner</p>	<p>A Connect and tighten spark plug wire.</p> <p>B Adjust carburetor.†</p> <p>C Clean air cleaner.†</p>
3 Operation erratic	<p>A Dirt in fuel tank</p> <p>B Dirty air cleaner</p> <p>C Water in fuel supply</p> <p>D Vent in gas cap plugged</p> <p>E Carburetor improperly adjusted</p>	<p>A Remove the dirt and fill tank with fresh fuel.</p> <p>B Clean air cleaner.†</p> <p>C Drain contaminated fuel and fill tank with fresh fuel.</p> <p>D Clear vent or replace gas cap.</p> <p>E Adjust carburetor.†</p>
4 Occasional skip (hesitates) at high speed	<p>A Carburetor idle speed too slow</p> <p>B Spark plug gap too close</p> <p>C Carburetor idle mixture adjustment improperly set</p>	<p>A Adjust carburetor.†</p> <p>B Adjust to .030".</p> <p>C Adjust carburetor.†</p>
5 Idles poorly	<p>A Spark plug fouled, faulty, or gap too wide</p> <p>B Carburetor improperly adjusted</p> <p>C Dirty air cleaner</p>	<p>A Reset gap to .030" or replace spark plug.</p> <p>B Adjust carburetor.†</p> <p>C Clean air cleaner.†</p>
6 Engine overheats	<p>A Carburetor not adjusted properly</p> <p>B Air flow restricted</p> <p>C Engine oil level low</p>	<p>A Adjust carburetor.†</p> <p>B Remove blower housing and clean.†</p> <p>C Fill crankcase with the proper oil or fuel mixture.</p>
7 Excessive vibration	<p>A Cutting blade loose or unbalanced</p> <p>B Bent cutting blade</p>	<p>A Tighten blade and adapter. Balance blade.</p> <p>B Replace blade.</p>

†Refer to separate engine manual packed with your unit.

Note: For repairs beyond the minor adjustments listed above, contact your local authorized service dealer.

PARTS INFORMATION

POWER EQUIPMENT PARTS AND SERVICE

Parts and service are available through the authorized service firms listed below. All orders should specify the model number of your unit, part numbers, description of parts and the quantity of each part required.

BRIGGS AND STRATTON, TECUMSEH AND PEERLESS PARTS AND SERVICE

Briggs & Stratton, Tecumseh and Peerless parts and service should be handled by your nearest authorized engine service firm. Check the yellow pages of your telephone directory under the listing **Engines—Gasoli**. Briggs & Stratton or Tecumseh Lauson.

NOTE: If any parts are found to be missing or defective upon assembly of this unit, write to advise the factory so that immediate replacement can be made.

ALABAMA	BIRMINGHAM	NEW YORK	CARTHAGE
Auto Electric & Carburetor Co.	2625 4th Ave. S. 35233	Gamble Dist., Inc.	West End Ave. 13619
ARKANSAS	NORTH LITTLE ROCK	NORTH CAROLINA	GREENSBORO
Sutton's Lawn Mower Shop.	5301 Roundtop Drive	Dixie Sales Company	335 N. Green 27402
	Box 368, Rt. 4 72117	OHIO	CARROLL
CALIFORNIA	PORTERVILLE	Stebe's Mid-State Mower Supply	Box 366, 71 High St. 43112
Billious	75 North D Street 93257		CLEVELAND
COLORADO	DENVER	Bleckrie, Inc.	7900 Lorain Ave. 44102
Spitzer Industrial Products Co.	6601 N.	National Central	WADSWORTH
	Washington St. 80229	Burton Supply Co.	687 Seville Rd. 44281
FLORIDA	JACKSONVILLE		YOUNGSTOWN
Radco Distributors	4909 Victor St.		1301 Logan Ave.
	Box 5459 32207		Box 929 44501
	HIALEAH	OREGON	PORTLAND
Small Eng. Dist.	7995 W. 26th Court 33016	Kenton Supply Co.	8216 N. Denver Ave. . . . 97217
GEORGIA	EAST POINT	PENNSYLVANIA	HARRISBURG
East Point Cycle & Key Inc.	2834 Church St. 30344	EECO Inc.	4021 N. 6th St. 17110
ILLINOIS	LYONS	Thompson Rubber Co.	WILLOW GROVE
Keen Edge Co.	8615 Ogden Ave. 60534		850 Davisville Rd. 19090
INDIANA	ELKHART	Bluemont Co.	PITTSBURGH
Parts & Sales Inc.	2101 Industrial Pkwy. . . . 46516	Frank Roberts & Sons	R.D. 2 15767
IOWA	DUBUQUE	Scranton Auto Ignition Co.	SCRANTON
Power Lawn & Garden Equip.	2551 J.F. Kennedy 52001		1133-35 Wyoming Ave. . . 18509
LOUISIANA	NEW ORLEANS	TENNESSEE	KNOXVILLE
Suhren Engine Co.	8330 Earhart Blvd. 70118	Ace Distributors	2103 Magnolia 379
MARYLAND	TAKOMA PARK	American Sales & Service, Inc.	MEMPHIS
Center Supply Co.	6867 New Hampshire		3035-43 Bellbrook 381
	Ave. 20912	TEXAS	DALLAS
MASSACHUSETTS	SPRINGFIELD	Marr Brothers, Inc.	423 E. Jefferson 75203
Morton B. Collins Co.	300 Birnie Ave. 01107	Woodson Sales Corp.	FORT WORTH
MICHIGAN	LANSING		6733 Baker Blvd.
Lorenz Service Co.	2500 S. Pennsylvania . . . 48910		Hwy. 10 76118
	MOUNT CLEMENS		SAN ANTONIO
Power Equipment Dist.	340 Hubbard 48043	Engine House Inc.	8610 Botts Lane
MINNESOTA	HOPKINS		P.O. Box 17867 78217
Hance Distributing Inc.	420 Excelsior Ave. W. . . . 55343	UTAH	SALT LAKE CITY
MISSOURI	EARTH CITY	Powered Products	1661 N. Beck St. 84116
Oscar Wilson Engine & Parts	4159 Shoreline Dr. 63045	VIRGINIA	ASHLAND
	KANSAS CITY	RBI Corp.	101 Cedar Ridge Dr. . . . 23005
Automotive Equip. Service	3117 Holmes St. 64109	WASHINGTON	SEATTLE
Ross-Frazier Supply Co.	ST. JOSEPH	Equip. Northwest	1410 14th Ave. 98122
	8th and Monterey 64503	WISCONSIN	MILWAUKEE
Henzler, Inc.	ST. LOUIS	Wisconsin Magneto Inc.	4727 N. Teutonia St. . . . 53209
	2015 Lemay Ferry Rd. . . . 63125		
NEW JERSEY	ALLOWAY		
Piersons	Canal St. 08001		
NEW MEXICO	ALBUQUERQUE		
Spitzer Eng. & Parts Co.	1023 Third Ave. N.W. . . . 87103		

WARRANTY PARTS AND SERVICE POLICY

(0686)

The purpose of warranty is to protect the customer from defects in workmanship and materials, defects which are NOT detected at the time of manufacture. It does not provide for the unlimited and unrestricted replacement of parts. Use and maintenance are the responsibility of the customer. The manufacturer cannot assume responsibility for conditions over which it has no control. Simply put, if it's the manufacturer's fault, it's the manufacturer's responsibility; if it's the customer's fault, it's the customer's responsibility.

CLAIMS AGAINST THE MANUFACTURER'S WARRANTY INCLUDES:

1. Replacement of Missing Parts on new equipment.
2. Replacement of Defective Parts within the warranty period.
3. Repair of Defects within the warranty period.

All claims MUST be substantiated with the following information:

1. Model Number, Serial Number and/or Data Code of unit involved.
2. Date unit was purchased or first put into service.
3. Date of Failure.
4. Nature of Failure.