

# Owner's Operating Service Instruction Manual

10¢

Model No.  
124-270A

- ASSEMBLY
- OPERATION
- REPAIR PARTS

## 22" SELF-PROPELLED ROTARY MOWER

### WARRANTY

For one year from date of purchase, MTD Products Inc will replace for the original purchaser, free of charge, F.O.B. factory or authorized service firm, any part or parts found to be defective in material or workmanship. All transportation charges on parts submitted for replacement under this warranty must be paid by the purchaser. This warranty does not include replacement of parts which become inoperative through misuse, excessive use, accident, neglect, improper maintenance or alterations by unauthorized persons. This warranty does not include the engine, motor, battery, battery charger or any component parts thereof. For service on these units, refer to the applicable manufacturer's warranty.

The above warranty will apply only to the original owner and will be effective only if the warranty card has been properly processed. It will not apply where the unit has been used commercially.

Warranty service is available through your local authorized service dealer or distributor. **UNDER NO CIRCUMSTANCES WILL THE RETURN OF A COMPLETE UNIT BE ACCEPTED BY THE FACTORY UNLESS PRIOR WRITTEN PERMISSION HAS BEEN EXTENDED.**

# I M P O R T A N T

## SAFE OPERATION PRACTICES FOR WALK-BEHIND MOWERS

### TRAINING

1. Read the Operating and Service Instruction Manual carefully. Be thoroughly familiar with the controls and the proper use of the equipment.
2. Never allow children to operate a power mower.
3. Keep the area of operation clear of all persons, particularly small children and pets.

### PREPARATION

1. Thoroughly inspect the area where the equipment is to be used and remove all stones, sticks, wire, bones and other foreign objects.
2. Do not operate equipment when barefoot or wearing open sandals. Always wear substantial footwear.
3. Check the fuel before starting the engine. Do not fill the gasoline tank indoors, when the engine is running, or while the engine is still hot. Wipe off any spilled gasoline before starting the engine.
4. Disengage the self-propelled mechanism or drive clutch on units so equipped before starting the engine (motor).
5. Never attempt to make a wheel adjustment while the engine (motor) is running.
6. Mow only in daylight or in good artificial light.
7. Never operate the equipment in wet grass. Always be sure of your footing; keep a firm hold on the handle and walk, never run.
5. If the equipment should start to vibrate abnormally, stop the engine (motor) and check immediately for the cause. Vibration is generally a warning of trouble.
6. Stop the engine (motor) whenever you leave the equipment, before cleaning the mower housing, and when making any repairs or inspections.
7. When cleaning, repairing or inspecting, make certain the blade and all moving parts have stopped. Disconnect the spark plug wire, and keep the wire away from the plug to prevent accidental starting.
8. Do not run the engine indoors.
9. Shut the engine (motor) off and wait until the blade comes to a complete stop before removing the grass catcher or unclogging chute.
10. Mow across the face of slopes, never up-and-down. Exercise extreme caution when changing direction on slopes. Do not mow excessively steep slopes.
11. Always disconnect electric mowers (line operated) before cleaning, repairing or adjusting.
12. Never operate mower without proper guards, plates or other safety protective devices in place.
13. Keep washout ports and other mower-housing service openings closed when mowing.

### OPERATION

1. Do not change the engine governor settings or overspeed the engine.
2. Do not put hands or feet near or under rotating parts. Keep clear of the discharge opening at all times.
3. Stop the blade(s) when crossing gravel drive, walks or roads.
4. After striking a foreign object, stop the engine (motor), remove the wire from spark plug, thoroughly inspect the mower for any damage, and repair the damage before restarting and operating the mower.

### MAINTENANCE AND STORAGE

1. Check the blade and engine mounting bolts at frequent intervals for proper tightness.
2. Keep all nuts, bolts, and screws tight to be sure the equipment is in safe working condition.
3. Never store the equipment with gasoline in the tank inside of a building where fumes may reach an open flame or spark. Allow the engine to cool before storing in any enclosure.
4. To reduce fire hazard, keep the engine free of grass, leaves, or excessive grease.
5. Check the grass catcher bag frequently for wear or deterioration. Replace with new bag for safety protection.

## HANDLE ASSEMBLY

**NOTE:** Follow instructions starting with Number 1 and continue through Number 6.

It may be necessary to spread the ends of the lower handle outward slightly to assure a snug fit against the bracket mounting area.

**3.** Place the throttle control on upper handle and secure with hex head bolt and nut.

**2.** Position upper handle in place and secure with two curved head bolts and hand knobs as shown.

**1.** Fasten lower handle in position in handle mount brackets on deck. Secure with cotter pins as shown.

Cable Clip

Ferrule

Cotter Pin

Clutch Rod

**5.** Secure throttle control cable to handle with cable clips provided.

**6.** Check ALL nuts and bolts for correct tightness.

**4.** Thread the clutch rod into the ferrule until the ferrule lines up with the hole in the lower handle. Secure ferrule in handle with cotter pin as shown.

## CAUTION

Please note that the chute deflector on your mower is in an upright position. It is held in that position by a shipping block. This block is used for shipping purposes only. It must be removed and discarded before your mower is put into operation.

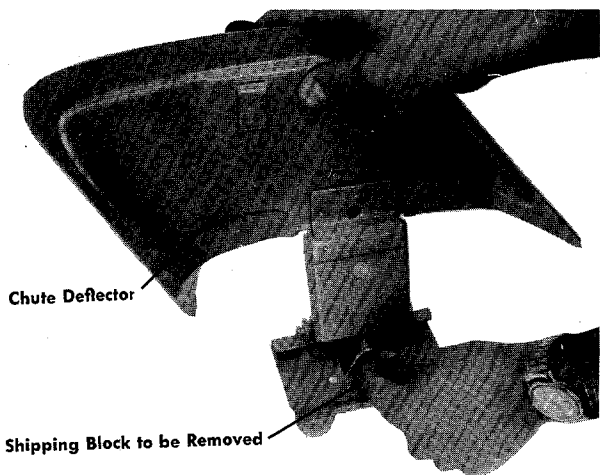

This mower should be broken in following the procedure described in the break-in instructions. The added effort here will double the service life of the unit. Particular attention should be paid to the notes on alignment.

When operating this mower, unnecessary or excessive engaging of the drive pinions with the wheels should be avoided. This is achieved by minimizing the raising and lowering of the handle during the mowing operation. Failure to observe this operating rule can reduce the service life of the front tires and drive pinions substantially. When engaging the self-propelled mechanism, a slight forward push on the mower as the drive pinions and the gear tread tires mesh will add to smoother and quieter operation. In addition to a smoother operation, it will add substantially to the service life of both the tires and the drive pinions.

## HANDLE ASSEMBLY PRECAUTIONS

Although the handle is of simple design, difficulty has been encountered in its assembly. Certain precautions concerning its assembly must be heeded. The handle must be assembled as shown in the diagram on page 3. Trouble arises when certain parts are put together improperly.

## BREAK-IN INSTRUCTIONS

1. Before starting the engine, lubricate all the bronze bearings on the drive shaft. The same oil which is used for the engine may be used for this.
2. Check drive assembly alignment. When the handle is lifted the clutch rod is moved to the self-propelled position. The black nylon drive pinions should mesh simultaneously with the gear tread tires.

## OPERATION

1. Service engine with gas and oil. See Engine Maintenance for complete instructions for care and maintenance of engine. READ DIRECTIONS CAREFULLY.
2. Lubricate bronze bearings on drive shaft.
3. Check drive assembly for correct alignment (See Break-in Instructions).
4. When ready to start engine, be sure handle is all the way back into free wheeling position. Start engine. After engine starts, move throttle control lever on handle to the desired engine speed.
5. When the handle is moved forward for self-propelled operation, the drive pinions engage with the gear tread tires and forward drive results.
6. Temporary free wheeling is achieved by depressing the handle and raising front wheels slightly off the ground. Self-propelled drive is resumed when handle is raised. Engine is stopped by placing control lever on handle into STOP position.

## LUBRICATION

**IMPORTANT:** Always stop engine and disconnect spark plug wire before cleaning, lubricating or doing any kind of work on lawn mower.

**Wheel Bearings**—Drive wheels are equipped with sintered bearings. Lubricate at least once a season with light oil. Rear wheel bearings are of self-lubricating Fortiflex. They require no lubrication.

**Throttle**—Periodically lubricate throttle control lever and throttle wire assembly with a few drops of light oil SAE No. 10 or 20 for ease of operations.

**Bronze Bearings**—Periodically lubricate all bronze bearings with a few drops of light oil SAE No. 10 or 20 to minimize friction.

**Protective Shield**—The pivot points on the protective shield should be lubricated periodically with light oil to prevent any rust or binding.

**Chute Deflector**—The torsion spring and pivot point should be lubricated periodically with light oil to prevent any rust or binding. Deflector must work freely.

**Engine**—See Engine Maintenance for lubrication instructions.

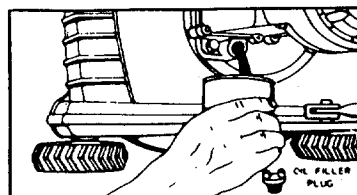

**NOTE: FILL AND DRAIN OIL FROM OIL FILL PLUG.**

## ADJUSTMENTS

**CAUTION:** Do not at any time make any adjustment to lawn mower without first stopping engine and disconnecting spark plug wire.

### Chain Adjustment—

1. Loosen (do not remove) two hex head cap screws (See illustration below.)
2. Pull pivot plate forward.
3. Tighten cap screws and check chain tension. Repeat adjustment if necessary.

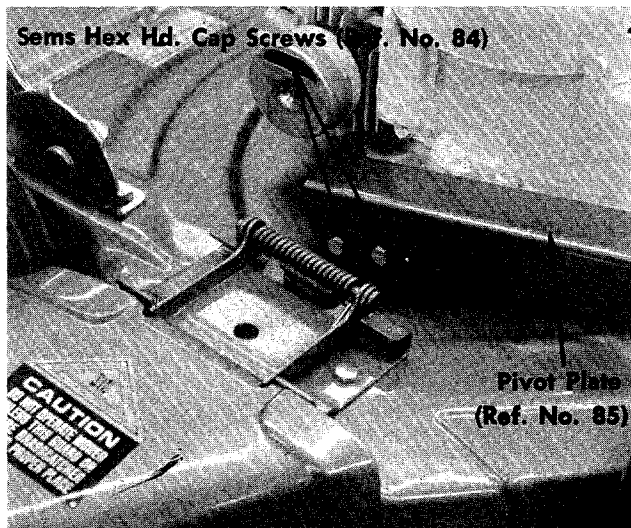

**Cutting Height**—An adjusting plate and thumb lever at each wheel position provides cutting height adjustment. Each adjusting plate has five holes. Height of cut will be changed when the thumb lever is moved from one hole to another. Simply depress thumb lever towards wheel and move wheel and lever assembly to desired position. All wheels must be positioned in relative height of cut position.

**Throttle**—If adjustment becomes necessary, the throttle control wire assembly can be reset as follows:

1. Loosen, but do not remove, screw securing throttle control wire assembly at engine.
2. Move throttle control lever on handle to FAST position.
3. Move lever, to which control wire is fastened at engine, to full open position and retighten screw to secure throttle control wire assembly.

### CLUTCH ROD ADJUSTMENT

1. Remove the cotter pin. See figure A.
2. Pull the clutch rod and ferrule out of the lower handle. See figure B.
3. Thread the ferrule on or off the rod one turn and check for alignment.
4. Place ferrule back in position and secure with cotter pin. If the engagement is still not correct, repeat the above steps.
5. The drive pinion should be about  $\frac{1}{8}$ " from the drive wheels. See figure C.
6. Figures D, E, F and G will give the approximate length of rod that should be showing for each cutting height.

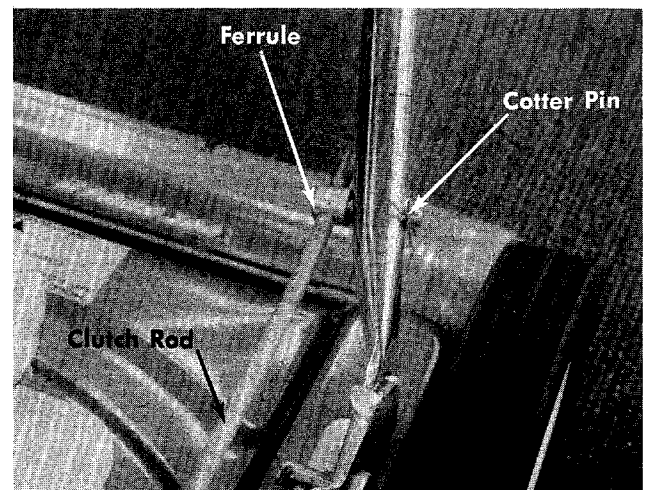

FIGURE A.

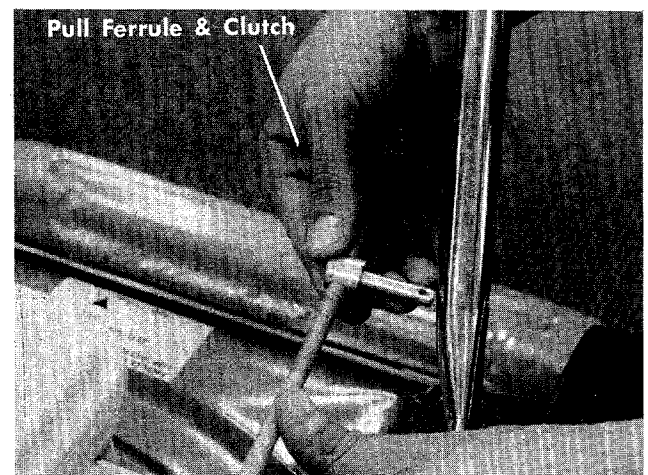
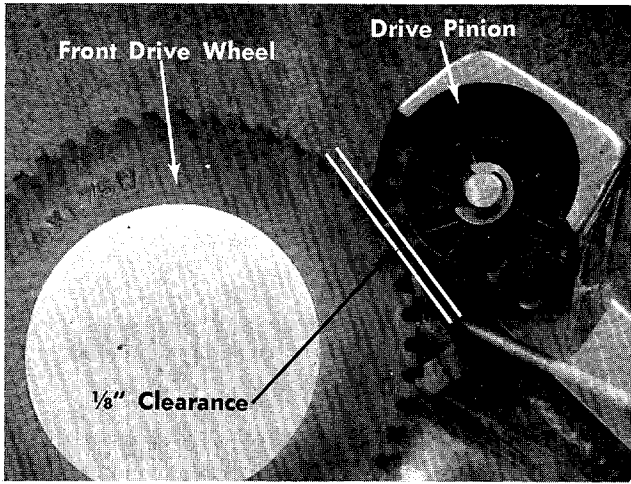
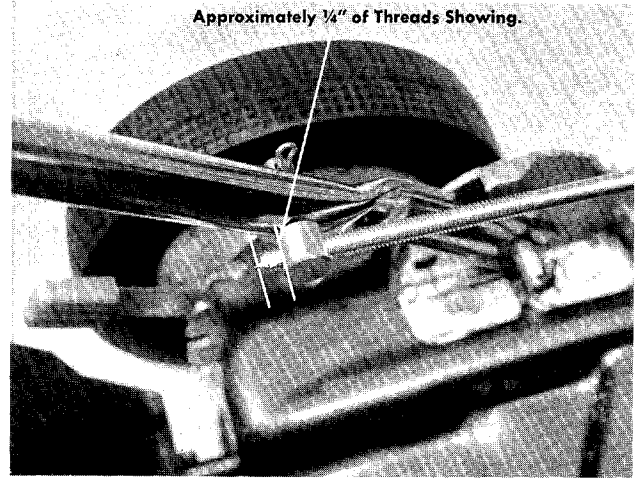

FIGURE B.



**FIGURE C.**



**FIGURE E. CLUTCH ROD SETTING FOR THE MIDDLE CUTTING HEIGHT.**

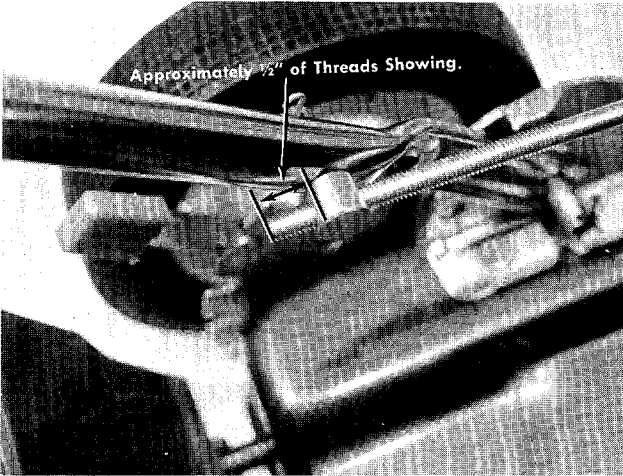

**FIGURE D. CLUTCH ROD SETTING FOR THE FIRST AND SECOND HIGHEST CUTTING HEIGHT**

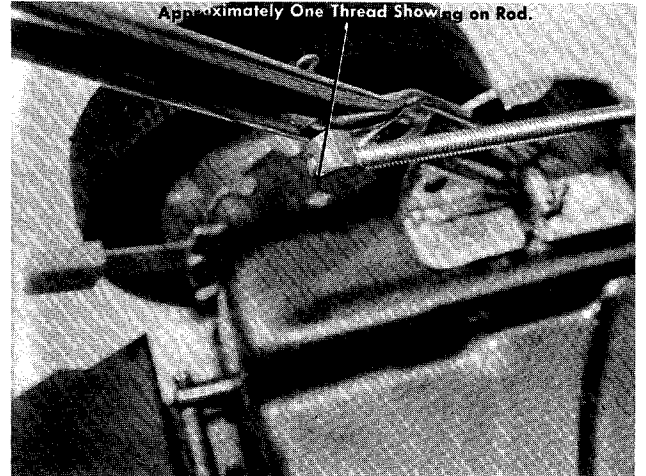

**FIGURE F. CLUTCH ROD SETTING FOR THE SECOND LOWEST CUTTING HEIGHT**

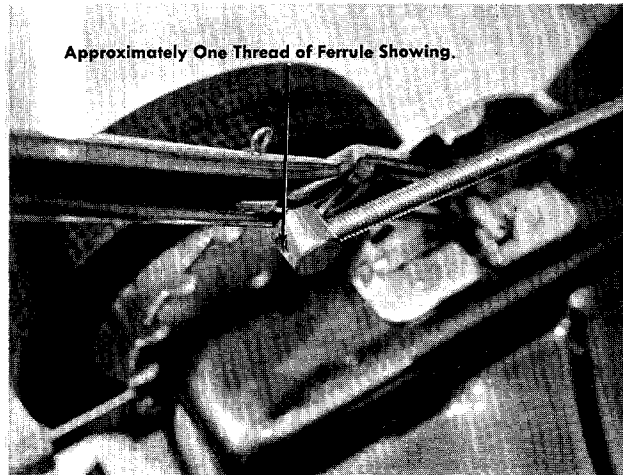

**FIGURE G. CLUTCH ROD SETTING FOR THE LOWEST CUTTING HEIGHT.**

## **MAINTENANCE**

**Cutting Blade**—The blade may easily be removed for grinding or replacement as follows:

1. Remove bolt and lockwasher holding blade and blade adapter to engine crankshaft.
2. Remove blade and blade adapter from engine crankshaft.
3. Remove two bolts, lockwashers and nuts holding blade to blade adapter (if necessary).

When sharpening blade, follow the original angle of grind as a guide. It is extremely important that each cutting edge receives an equal amount of grinding to prevent an unbalanced blade. An unbalanced blade will cause excessive vibration when rotating at high speeds and may cause damage to the mower.

Upon reassembly, make certain all parts are assembled properly and tightened securely.

To insure safe operation of your unit, all nuts and bolts must be checked periodically for correct tightness.

**Deck**—The underside of mower deck should be cleaned after each period of use as grass clippings, leaves, dirt and other matter will accumulate. This accumulation of grass clippings, etc., is undesirable as it will invite corrosion and cause an uneven discharge of grass clippings at the next cutting.

The deck may be cleaned by tilting the mower forward or on its left side and scraping clean with a suitable tool or by washing with a stream of water from a garden hose.

**CAUTION:** Do not direct the stream of water at a hot engine as damage to the engine may result.

**Storage**—The following steps should be taken to prepare lawn mower for storage.

1. Clean and lubricate mower thoroughly as described in the preceding instructions.
2. Refer to engine manual for correct engine storage instructions.
3. Coat mower's cutting blade with chassis grease to prevent rusting.
4. Place blocks under deck to raise tires clear of floor.
5. Store mower in a dry, clean area.

## **USING YOUR ROTARY MOWER**

For best results do not cut wet grass because it tends to stick to the underside of the mower thus preventing proper discharge of grass clippings. If wet grass must be cut, reduce engine speed and walking speed to help distribute the clippings more effectively.

New grass should be treated as wet grass, otherwise a normal walking speed is about the right pace for efficient mowing.

The best mowing pattern is one that allows the clippings to discharge towards the uncut part of the lawn. This permits recutting of the clippings to further pulverize them. When cutting high weeds, discharge towards cut portion then recut at right angles to first direction.

Lawn should be cut in the fall as long as there is growth.

# 124-270A

IF YOU WRITE TO US ABOUT THIS ARTICLE  
OR IF YOU ORDER REPLACEMENT PARTS AL-  
WAYS MENTION THIS MODEL & SERIAL NO  
MODEL

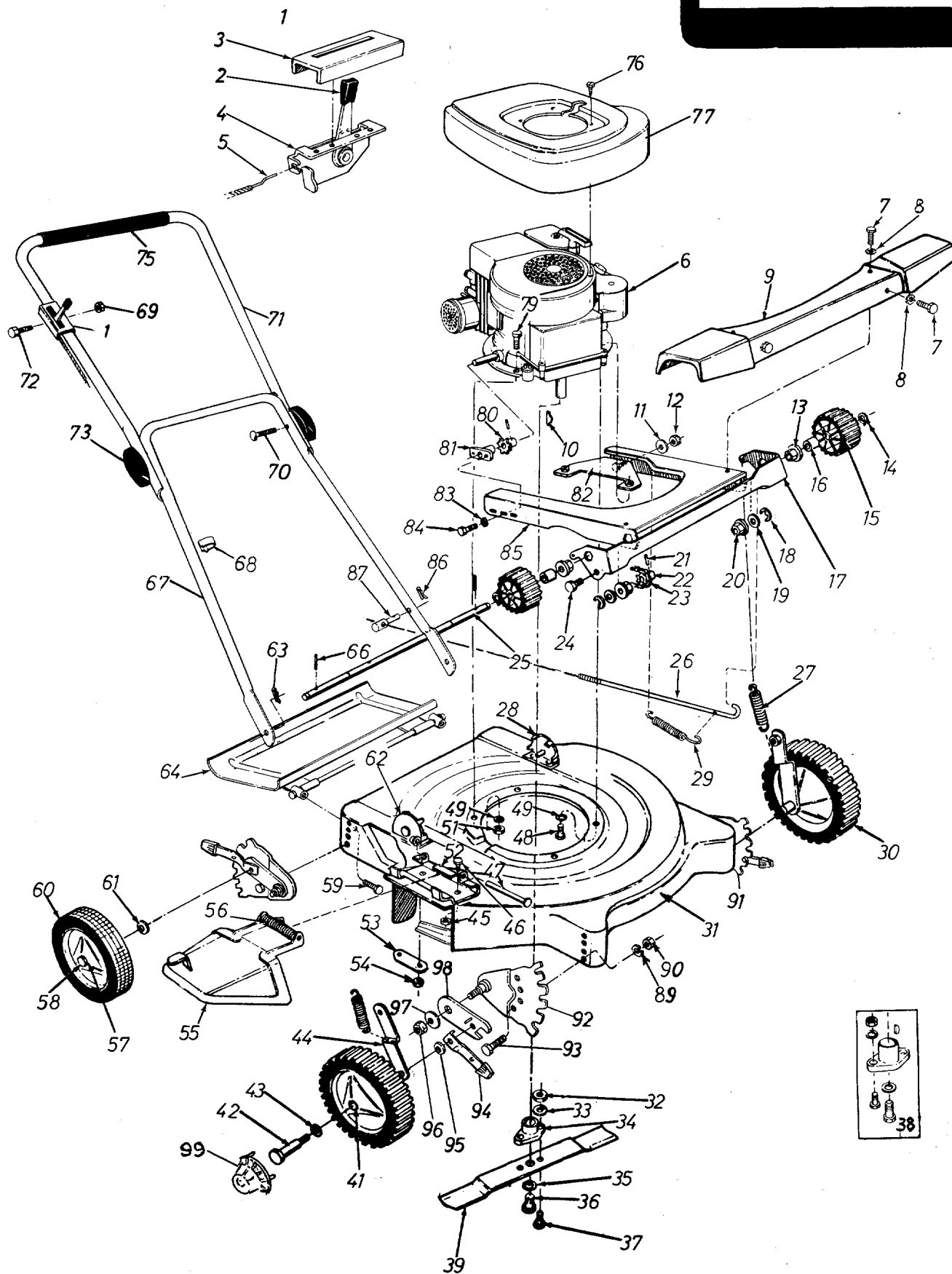



**PARTS LIST FOR MODEL 124-270A**

REF. NO.	PART NO.	COLOR CODE	DESCRIPTION	NEW PART	REF. NO.	PART NO.	COLOR CODE	DESCRIPTION	NEW PART
1	11601		Throttle Control Ass'y. Comp.		48	710-442		Hex Hd. Cap Scr. 5/16-18 x 1.50" Lg.*	
2	7470		Throttle Control Knob		49	736-119		Spring Lockwasher 5/16" Scr.*	
3	731-180		Plastic Label		51	712-123		Hex Nut 5/16-24 Thd.*	
4	11598		Throttle Control Ass'y.		52	11130—458		Adapter Plate	
5	746-228		Conduit and Wire		53	8405		Reinforcement Plate	
6	—		Engine		54	712-107		Hex Center Locknut 1/4-20 Thd.	
7	710-289		Hex Hd. Cap Scr. 1/4-20 x .50" Lg.*		55	11679—458		Chute Deflector Ass'y. Comp.	
8	736-222		External Lockwasher 1/4" Scr.*		56	732-253		Torsion Spring	
9	10913—458		Drive Cover		57	7006		Fortiflex Bearing (Rear Wheels Only)	
10	714-365		#6 Hi-Pro Key 5/32 x 5/8" Dia.		58	738-133		Shoulder Scr. .498" Dia. x 1.450 (Axle Bolt—Rear)	
11	736-300		Flat Washer .385" I.D. x .87" O.D. x .06		59	710-567		Hex Hd. Cap Scr. 1/4-28 x .62" Lg.	
12	712-116		Elastic Locknut 3/8-24 Thd.		60	9392-501		Wheel Ass'y. Comp.—Rear	
13	748-227		Hex Flange Bearing .630 I.D. Bronze		61	736-105		Belleville Washer	
14	716-106		"E"-Ring for 5/8" Shaft		62	11802		Handle Mtg. Brkt. Ass'y.—R.H.	
15	10914		Drive Pinion		63	714-104		Hair Pin Cotter	
16	2265		Sleeve .44" Dia. x 16 ga.		64	11197—458		Protective Shield Ass'y. Comp.	
17	10372—458		Drive Support		66	715-246		Spring Pin Spirol 3/16 x 1.25" Lg.	
18	716-106		"E"-Ring for 5/8" Shaft		67	11616		Lower Handle	
19	736-116		Flat Washer .635" I.D. x 93" O.D. x .060		68	746-128		Cable Clip for 3/8" Tubing	
20	748-227		Hex Flange Bearing .630" I.D. Bronze		69	712-107		Hex Center Locknut 1/4-20 Thd.	
21	715-247		Roll Pin 3/16" Dia. x 1.00" Lg.*		70	710-405		Curved Hd. Bolt 5/16-18 x 1 1/4"	
22	10378		Sprocket Ass'y. 8 Tooth		71	11204		Upper Handle	
23	713-135		Chain with Master Link #48 x 26" Lg.		72	710-606		Hex Hd. Cap Scr. 1/4-20 x 1.50" Lg.*	
24	738-147		Shoulder Scr. .500" Dia. x .170		73	9966		Hand Knob	
25	711-435		Drive Shaft		75	718-144		Grip	
26	12119		Clutch Rod		76	710-407		Slot Hex Hd. Self Ext. #8-32 x .50	
27	732-209		Extension Spring		77	10877—452		Shroud	
28	11801		Handle Mtg. Brkt. Ass'y.—L.H.		79	710-158		Hex Hd. Cap Scr. 5/16-24 x 1.25" Lg.*	
29	732-433		Tension Spring		80	10377		Sprocket Ass'y. 8 Tooth	
30	9392-503		Front Wheel Ass'y. Comp.		81	748-183		Bearing Support	
31	11820—458		Deck Ass'y.		82	10381—458		Engine Bracket Ass'y.	
32	712-123		Hex Nut 5/16-24 Thd.*		83	736-222		External Lockwasher 1/4" Scr.*	
33	736-119		Spring Lockwasher 5/16" Scr.*		84	710-230		Hex Hd. Cap Scr. 1/4-28 x .50" Lg.*	
34	10769		Blade Adapter Kit		85	11240		Pivot Plate Ass'y.	
35	736-217		Spring Lockwasher 3/8" Scr. Heavy Duty		86	714-104		Internal Cotter Pin 1/2" Dia.	
36	710-459		Hex Hd. Cap Scr. 3/8-24 x 1.50" Lg. H. T.		87	711-570		Engagement Ferrule	
37	710-117		Hex Hd. Cap Scr. 5/16-24 x 1.00" Lg. H. T.		89	736-169		Spring Lockwasher 3/8" Scr.*	
38	10769		Blade Adapter Kit		90	712-798		Hex Nut 3/8-16 Thd.*	
39	742-125		22 inch Blade		91	10944		Index Plate Ass'y.—L.H.	
40	736-105		Belleville Washer		92	10919		Index Plate Ass'y.—R.H.	
41	748-125		Sintered Bearing		93	710-209		Sems Hex Scr. 3/8-16 x .62" Lg.*	
42	738-144		Shoulder Scr. .498" Dia. x 1.640 (Axle Bolt Front Only)		94	10533		Spring Lever Ass'y. with Knob	
43	736-160		Flat Washer .385" I.D. x .87 O.D. x .06		95	736-105		Belleville Washer	
44	10918		Link Assembly		96	712-116		Elastic Locknut 3/8-24 Thd.	
45	712-107		Hex Center Locknut 1/4-20 Thd		97	736-219		Belleville Wash.	
46	710-289		Hex Hd. Cap Scr. 1/4-20 x .50" Lg.		98	10619		Pivot Bar	
47	711-555		Pivot Pin		99	731-124		Hub Caps	
					100	751-109		Dip Stick (Not Shown)	

(458—Arctic Blue) *When ordering parts if color or finish is important, use the appropriate color code shown at left.*  
 (e.g. Arctic Blue Finish—10913—(458).) 9

The engine is not under warranty by the mower manufacturer. If repairs or service is needed on the engine, please contact your nearest authorized engine service outlet. Check the "Yellow Pages" of your telephone book under "Engines—Gasoline."



**NOTE**

The manufacturer DOES NOT recommend the use of any accessory on this rotary mower other than those manufactured by MTD Products Inc.

GRASS CATCHER Model No. 194-003A is available as optional equipment for the mowers shown in this manual.

**WARNING:**

1. The mower should not be operated without the entire grass catcher or chute deflector in place.
2. The mower should not be operated without the protective shield on the rear of the deck in place.

**NOTE:**

Under normal usage bag material is subject to wear and should be checked periodically. Be sure any replacement bag complies with the mower manufacturer's recommendations.

For replacement bags, use only factory authorized replacement bag No. 764-119.

**★ IMPORTANT**

After striking a foreign object, stop the engine (motor), remove wire from spark plug. Thoroughly inspect the mower for any damage, and repair the damage before restarting and operating the mower.

# PARTS INFORMATION

**DEFECTIVE OR MISSING PARTS** must be reported to the factory immediately. Such claims must include your model number and date of purchase.

## POWER EQUIPMENT PARTS AND SERVICE

Parts and service for all MTD manufactured power equipment are available through the authorized service firms listed below. All orders should specify the model number of your unit, parts numbers, description of parts and the quantity of each part required.

**A 1 Engine & Mower Co.**  
327 East 9th Street  
Salt Lake City, Utah 84102

**American Electric Ignition Co.**  
124 N. W. 8th Street  
Oklahoma City, Oklahoma 73102

**Auto Electric & Carburetor Co.**  
2525 4th Avenue, S.  
P. O. Box 1948  
Birmingham, Alabama 35233

**Automotive Equipment Service Co.**  
3117 Holmes Street  
Kansas City, Missouri 64109

**Bailey's Rebuild Inc.**  
1325 E. Madison Street  
Seattle Washington 98102

**Bleckie, Inc.**  
7900 Lorain Avenue  
Cleveland, Ohio 44102

**Brown Equipment Distributor Inc.**  
110 Beech Street  
Corydon, Indiana 47112

**Bullard Supply**  
2409 Commerce Street  
Houston, Texas 77003

**Carl A. Anderson Co.**  
623 S. 16th Street  
Omaha, Nebraska 68102

**Catto & Putty, Inc.**  
P. O. Box 2408  
510 Soledad Street  
San Antonio, Texas 78205

**Center Supply Company**  
6867 New Hampshire Avenue  
Takoma Park, Maryland 20012

**Dixie Sales Company**  
P. O. Box 1408  
327 Battleground Avenue  
Greensboro, North Carolina 27402

**East Point Cycle & Key Shop**  
1617 Whiteway  
East Point, Georgia 30044

**Gamble Distributors**  
West End Avenue  
Carthage, New York 13619

**Garden Equipment Co., Inc.**  
6600 Cherry Avenue  
Long Beach, California 90805

**Gardenville Supply, Inc.**  
Pipersville, Pennsylvania 18947

**Henry W. O'Neil & Assoc., Inc.**  
410 North Goodman Street  
Rochester, New York 14609

**Henzler, Inc.**  
2015 Lemay Ferry Road  
St. Louis, Missouri 63125

**Kenton Supply**  
8216 North Denver Avenue  
Portland, Oregon 97217

**Kimber's Inc.**  
115 W. Geddes St.  
Syracuse, New York 13204

**The Lawnmower Shop**  
1340 El Camino Real  
San Carlos, California 94070

**Marr Brothers**  
423 E. Jefferson  
Dallas, Texas 75203

**Mathews Auto Electric Co.**  
420 East 2nd Street  
Tulsa Oklahoma 74120

**McClure Lawn & Garden Supply**  
1114 Lexington Avenue  
Mansfield, Ohio 44907

**Memphis Cycle & Supply Co.**  
421 Monroe Avenue  
Memphis Tennessee 38103

**Morton B. Collins Co.**  
300 Birnie Avenue  
Springfield, Massachusetts 01107

**Mox-All of Florida, Inc.**  
365 Greco Avenue  
Coral Gables, Florida 33146

## BRIGGS & STRATTON, TECUMSEH AND PEERLESS PARTS AND SERVICE

Briggs & Stratton, Tecumseh and Peerless parts and service should be handled by your nearest authorized engine service firm. Check the yellow pages of your telephone directory under the listing *Engines — Gasoline*, Briggs & Stratton or Tecumseh Lauson — Power Products.

**National Central, Div. of**  
Joe Sterling, Inc.  
Drawer "D" 687 Seville Rd.  
Wadsworth, Ohio 44281

**Parts & Sales Inc.**  
2101 Industrial Pkwy.  
Elkhart, Indiana 46514

**Power Equipment Distributor**  
36463 So. Gratiot Avenue  
Mt. Clemens, Michigan 48043

**Power Lawn & Garden Equip. Co.**  
2551-2571 J. F. Kennedy Road  
Dubuque, Iowa 52001

**Radco Distributors**  
2403 Market Street  
P. O. Box 3216  
Jacksonville, Florida 32206

**Raub Supply Company**  
James & Mulberry Sts.  
Lancaster, Pennsylvania 17604

**Richmond Battery & Ignition**  
P. O. Box 25369 — 957 Myers St.  
Richmond, Virginia 23260

**Smith Hardware Company**  
515 N. George Street  
Goldsboro, North Carolina 27530

**South Denver Lawn Equip. Co.**  
527 West Evans  
Denver, Colorado 80223

**Suhren Engine**  
8330 Earhart Blvd.  
New Orleans, Louisiana 70118

**Sutton's Lawn Mower Shop**  
Route 4, Box 343  
North Little Rock, Arkansas 72117

**Warner Equipment**  
7520 Lyndale Avenue, So.  
Minneapolis, Minnesota 55423

**Woodson Sales & Service**  
1702 North Sylvania  
Ft. Worth, Texas 76111

## WARRANTY PARTS AND SERVICE POLICY

The purpose of warranty is to protect the customer from defects in workmanship and materials, defects which are NOT detected at the time of manufacture. It does not provide for the unlimited and unrestricted replacement of parts. Use and maintenance are the responsibility of the customer. The manufacturer cannot assume responsibility for conditions over which it has no control. Simply put, if it's the manufacturer's fault, it's the manufacturer's responsibility; if it's the customer's fault, it's the customer's responsibility.

### CLAIMS AGAINST THE MANUFACTURER'S WARRANTY INCLUDES

1. Replacement of Missing Parts on new equipment.
2. Replacement of Defective Parts within the warranty period.
3. Repair of Defects within the warranty period.

All claims MUST be substantiated with the following information:

1. Model Number of unit involved.
2. Date unit was purchased or first put into service.
3. Date of failure.
4. Nature of failure.