

Owner's Operating Service Instruction Manual

10¢

Model No.
124-260A

- ASSEMBLY
- OPERATION
- REPAIR PARTS

22" SELF-PROPELLED ROTARY MOWER

WARRANTY

For one year from date of purchase, MTD Products Inc will replace for the original purchaser, free of charge, F.O.B. factory or authorized service firm, any part or parts found to be defective in material or workmanship. All transportation charges on parts submitted for replacement under this warranty must be paid by the purchaser. This warranty does not include replacement of parts which become inoperative through misuse, excessive use, accident, neglect, improper maintenance or alterations by unauthorized persons. This warranty does not include the engine, motor, battery, battery charger or any component parts thereof. For service on these units, refer to the applicable manufacturer's warranty.

The above warranty will apply only to the original owner and will be effective only if the warranty card has been properly processed. It will not apply where the unit has been used commercially.

Warranty service is available through your local authorized service dealer or distributor. **UNDER NO CIRCUMSTANCES WILL THE RETURN OF A COMPLETE UNIT BE ACCEPTED BY THE FACTORY UNLESS PRIOR WRITTEN PERMISSION HAS BEEN EXTENDED.**

I M P O R T A N T

SAFE OPERATION PRACTICES FOR WALK-BEHIND MOWERS

TRAINING

1. Read the Operating and Service Instruction Manual carefully. Be thoroughly familiar with the controls and the proper use of the equipment.
2. Never allow children to operate a power mower.
3. Keep the area of operation clear of all persons, particularly small children and pets.

PREPARATION

1. Thoroughly inspect the area where the equipment is to be used and remove all stones, sticks, wire, bones and other foreign objects.
2. Do not operate equipment when barefoot or wearing open sandals. Always wear substantial footwear.
3. Check the fuel before starting the engine. Do not fill the gasoline tank indoors, when the engine is running, or while the engine is still hot. Wipe off any spilled gasoline before starting the engine.
4. Disengage the self-propelled mechanism or drive clutch on units so equipped before starting the engine (motor).
5. Never attempt to make a wheel adjustment while the engine (motor) is running.
6. Mow only in daylight or in good artificial light.
7. Never operate the equipment in wet grass. Always be sure of your footing; keep a firm hold on the handle and walk, never run.

OPERATION

1. Do not change the engine governor settings or overspeed the engine.
2. Do not put hands or feet near or under rotating parts. Keep clear of the discharge opening at all times.
3. Stop the blade(s) when crossing gravel drive, walks or roads.
4. After striking a foreign object, stop the engine (motor), remove the wire from spark plug, thoroughly inspect the mower for any damage, and repair the damage before restarting and operating the mower.

5. If the equipment should start to vibrate abnormally, stop the engine (motor) and check immediately for the cause. Vibration is generally a warning of trouble.
6. Stop the engine (motor) whenever you leave the equipment, before cleaning the mower housing, and when making any repairs or inspections.
7. When cleaning, repairing or inspecting, make certain the blade and all moving parts have stopped. Disconnect the spark plug wire, and keep the wire away from the plug to prevent accidental starting.
8. Do not run the engine indoors.
9. Shut the engine (motor) off and wait until the blade comes to a complete stop before removing the grass catcher or unclogging chute.
10. Mow across the face of slopes, never up-and-down. Exercise extreme caution when changing direction on slopes. Do not mow excessively steep slopes.
11. Always disconnect electric mowers (line operated) before cleaning, repairing or adjusting.
12. Never operate mower without proper guards, plates or other safety protective devices in place.
13. Keep washout ports and other mower-housing service openings closed when mowing.

MAINTENANCE AND STORAGE

1. Check the blade and engine mounting bolts at frequent intervals for proper tightness.
2. Keep all nuts, bolts, and screws tight to be sure the equipment is in safe working condition.
3. Never store the equipment with gasoline in the tank inside of a building where fumes may reach an open flame or spark. Allow the engine to cool before storing in any enclosure.
4. To reduce fire hazard, keep the engine free of grass, leaves, or excessive grease.
5. Check the grass catcher bag frequently for wear or deterioration. Replace with new bag for safety protection.

HANDLE ASSEMBLY

NOTE

It may be necessary to bend the ends of the lower handle inward slightly to assure a snug fit against the deck mounting area.

5. Fasten throttle control in handle panel with two self tapping screws as shown.

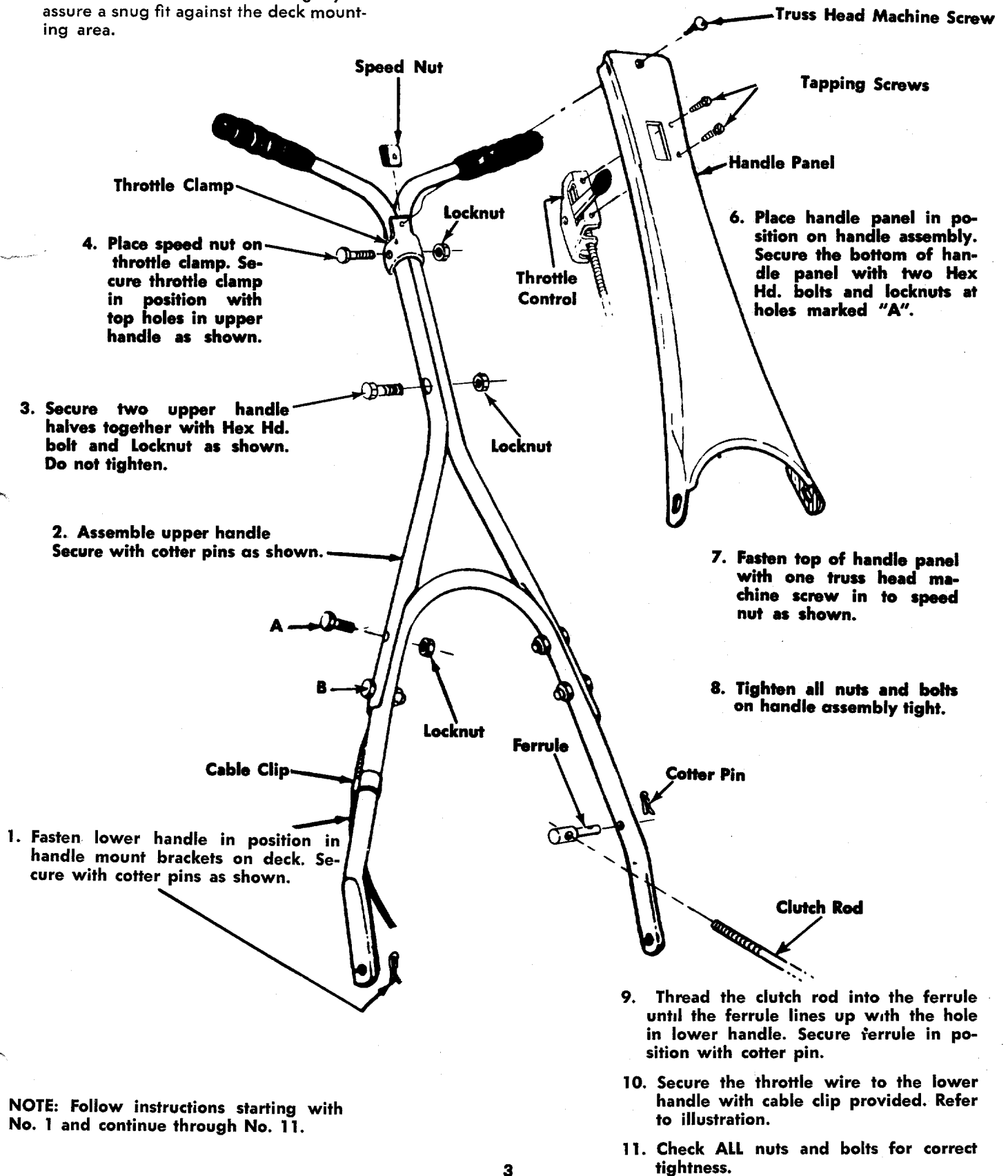

CAUTION

Please note that the chute deflector on your mower is in an upright position. It is held in that position by a shipping block. This block is used for shipping purposes only. It must be removed and discarded before your mower is put into operation.

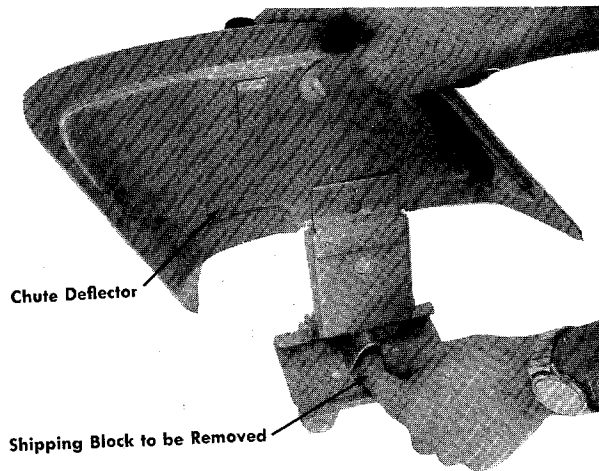

This mower should be broken in following the procedure described in the break-in instructions. The added effort here will double the service life of the unit. Particular attention should be paid to the notes on alignment.

When operating this mower, unnecessary or excessive engaging of the drive pinions with the wheels should be avoided. This is achieved by minimizing the raising and lowering of the handle during the mowing operation. Failure to observe this operating rule can reduce the service life of the front tires and drive pinions substantially. When engaging the self-propelled mechanism, a slight forward push on the mower as the drive pinions and the gear tread tires mesh will add to smoother and quieter operation. In addition to a smoother operation, it will add substantially to the service life of both the tires and the drive pinions.

HANDLE ASSEMBLY PRECAUTIONS

Although the handle is of simple design, difficulty has been encountered in its assembly. Certain precautions concerning its assembly must be heeded. The handle must be assembled as shown in the diagram on page 3. Trouble arises when certain parts are put together improperly.

BREAK-IN INSTRUCTIONS

1. Before starting the engine, lubricate all the bronze bearings on the drive shaft. The same oil which is used for the engine may be used for this.
2. Check drive assembly alignment. When the handle is lifted the clutch rod is moved to the self-propelled position. The black nylon drive pinions should mesh simultaneously with the gear tread tires.

OPERATION

NOTE

For shipping purposes your mower is set with the wheels in a low cutting height position. For best results, raise the cutting position until it is determined which height is best for your lawn. See adjustments.

1. Service engine with gas and oil. See Engine Maintenance for complete instructions for care and maintenance of engine. **READ DIRECTIONS CAREFULLY.**
2. Lubricate bronze bearings on drive shaft.
3. Check drive assembly for correct alignment (See Break-in Instructions).
4. When ready to start engine, be sure handle is all the way back into free wheeling position. Start engine, after engine starts, move throttle control lever on handle to the desired engine speed.
5. When the handle is moved forward for self-propelled operation, the drive pinions engage with the gear tread tires and forward drive results.
6. Temporary free wheeling is achieved by depressing the handle and raising front wheels slightly off the ground. Self-propelled drive is resumed when handle is raised. Engine is stopped by placing control lever on handle into STOP position.

LUBRICATION

IMPORTANT: Always stop engine and disconnect spark plug wire before cleaning, lubricating or doing any kind of work on lawn mower.

Wheels—Rear wheel bearings are of self-lubricating Fortiflex. They require no lubrication. Front drive wheels are equipped with sintered bearings. Lubricate at least once a season with light oil.

Throttle—Periodically lubricate throttle control lever and throttle wire assembly with a few drops of light oil SAE No. 10 or 20 for ease of operations.

Bronze Bearings—Periodically lubricate all bronze bearings with a few drops of light oil SAE No. 10 or 20 to minimize friction.

Protective Shield—The pivot points on the protective shield should be lubricated periodically with light oil to prevent any rust or binding.

Chute Deflector—The torsion spring and pivot point should be lubricated periodically with light oil to prevent any rust or binding. Deflector must work freely.

Engine—See Engine Maintenance for lubrication instructions.

ADJUSTMENTS

CAUTION: Do not at any time make any adjustment to lawn mower without first stopping engine and disconnecting spark plug wire.

Chain Adjustment—

1. Loosen (do not remove) two hex head cap screws (See illustration below.)
2. Pull pivot plate forward.
3. Tighten cap screws and check chain tension. Repeat adjustment if necessary.

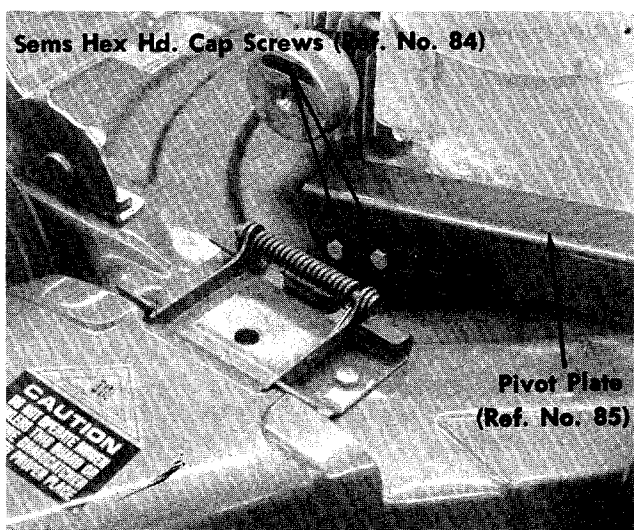

Cutting Height—Adjustment may be made by removing and moving wheel studs to desired position. Cutting heights will be raised as wheel studs are moved to a lower hole and lowered as wheel studs are moved to a higher hole in the deck. All wheel studs must be mounted in a relative position to the deck.

Throttle—If adjustment becomes necessary, the throttle control wire assembly can be reset as follows:

1. Loosen, but do not remove, screw securing throttle control wire assembly at engine.
2. Move throttle control lever on handle to FAST position.
3. Move lever, to which control wire is fastened at engine, to full open position and retighten screw to secure throttle control wire assembly.

CLUTCH ROD ADJUSTMENT

If adjustment becomes necessary, or if the cutting height is changed from the lowest setting to the highest setting the clutch rod must be reset as follows:

1. Remove the cotter pin. See figure A.

2. Pull the clutch rod and ferrule out of the lower handle. See figure B.
3. Thread the ferrule on or off the rod one turn and check for alignment.
4. Place ferrule back in position and secure with cotter pin. If the engagement is still not correct, repeat the above steps.
5. The drive pinion should be about $\frac{1}{8}$ " from the drive wheels. See figure C.

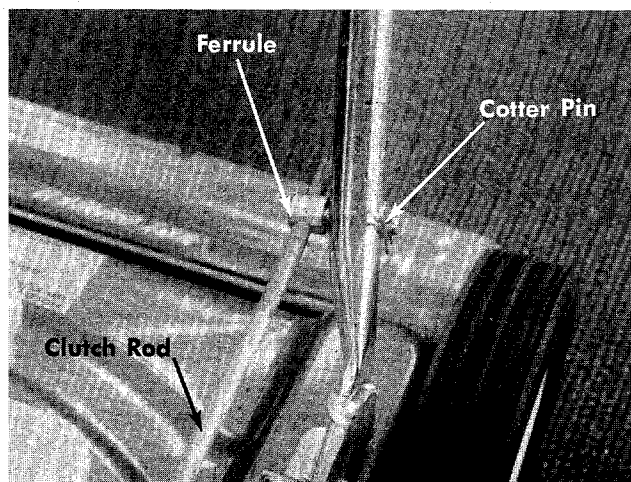

FIGURE A.

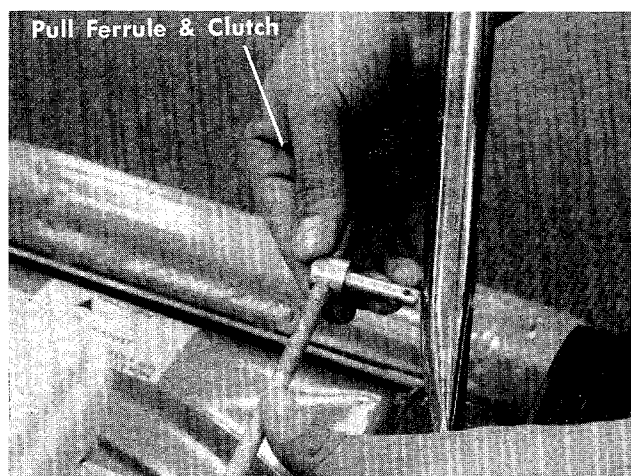

FIGURE B.

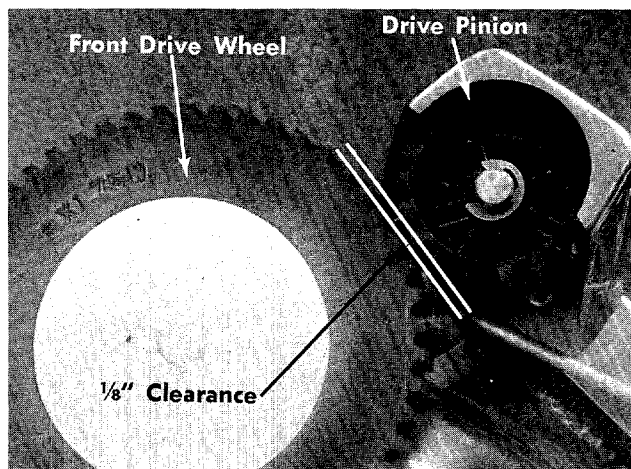

FIGURE C.

MAINTENANCE

Cutting Blade—The blade may easily be removed for grinding or replacement as follows:

1. Remove bolt and lockwasher holding blade and blade adapter to engine crankshaft.
2. Remove blade and blade adapter from engine crankshaft.
3. Remove two bolts, lockwashers and nuts holding blade to blade adapter (if necessary).

When sharpening blade, follow the original angle of grind as a guide. It is extremely important that each cutting edge receives an equal amount of grinding to prevent an unbalanced blade. An unbalanced blade will cause excessive vibration when rotating at high speeds and may cause damage to the mower.

To insure safe operation of your unit, ALL nuts and bolts must be checked periodically for correct tightness.

Deck—The underside of mower deck should be cleaned after each period of use as grass clippings, leaves, dirt and other matter will accumulate. This accumulation of grass clippings, etc., is undesirable as it will invite corrosion and cause an uneven discharge of grass clippings at the next cutting.

The deck may be cleaned by tilting the mower forward or on its left side and scraping clean with a suitable tool or by washing with a stream of water from a garden hose.

CAUTION: Do not direct the stream of water at a hot engine as damage to the engine may result.

Storage—The following steps should be taken to prepare lawn mower for storage.

1. Clean and lubricate mower thoroughly as described in the preceding instructions.
2. Refer to engine manual for correct engine storage instructions.
3. Coat mower's cutting blade with chassis grease to prevent rusting.
4. Place blocks under deck to raise tires clear of floor.
5. Store mower in a dry, clean area.

USING YOUR ROTARY MOWER

For best results do not cut wet grass because it tends to stick to the underside of the mower thus preventing proper discharge of grass clippings. If wet grass must be cut, reduce walking speed to help distribute the clippings more effectively.

New grass should be treated as wet grass, otherwise a normal walking speed is about the right pace for efficient mowing.

The best mowing pattern is one that allows the clippings to discharge towards the uncut part of the lawn. This permits recutting of the clippings to further pulverize them. When cutting high weeds, discharge towards cut portion, then recut at right angles to first direction.

Lawn should be cut in the fall as long as there is growth.

NOTE

The manufacturer DOES NOT recommend the use of any accessory on this rider mower other than those manufactured by MTD Products Inc.

GRASS CATCHER Model No. 194-003A is available as optional equipment for the mowers shown in this manual.

WARNING:

1. The mower should not be operated without the entire grass catcher or chute deflector in place.
2. The mower should not be operated without the protective shield on the rear of the deck in place.

NOTE:

Under normal usage bag material is subject to wear and should be checked periodically. Be sure any replacement bag complies with the mower manufacturer's recommendations.

For replacement bags, use only factory authorized replacement bag No. 764-119.

★ IMPORTANT

After striking a foreign object, stop the engine (motor), remove wire from spark plug. Thoroughly inspect the mower for any damage, and repair the damage before restarting and operating the mower.

124-260A

IF YOU WRITE TO US ABOUT THIS ARTICLE
OR IF YOU ORDER REPLACEMENT PARTS AL-
WAYS MENTION THIS MODEL & SERIAL NO
MODEL

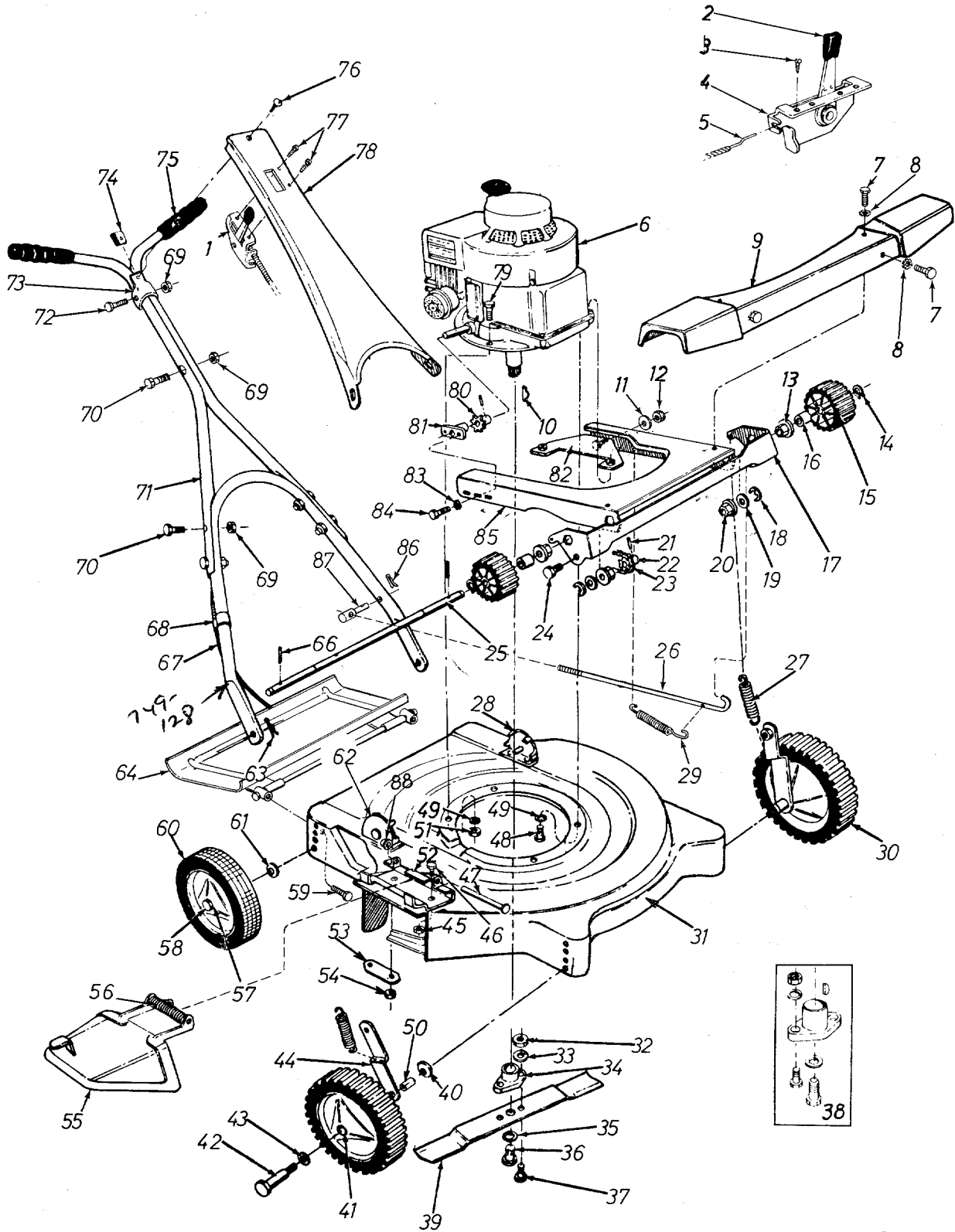

PARTS LIST FOR MODEL 124-260A

REF. NO.	PART NO.	COLOR CODE	DESCRIPTION	NEW PART	REF. NO.	PART NO.	COLOR CODE	DESCRIPTION	NEW PART
1	11597		Throttle Control Complete		46	710-289		Hex Scr. 1/4-20 x 1/2" Lg.*	
2	7470		Knob—Throttle Control		47	711-555		Pivot Pin	
3	710-407		Slot Hex Hd. Self Extr. Scr. No. 8-32 x 1/2" Lg.		48	710-442		Hex Hd. Cap Scr. 5/16-18 x 1 1/2" Lg.*	
4	11598		Throttle Control Ass'y.		49	736-119		Spring L-Wash. 5/16 Scr.*	
5	746-229		Conduit and Wire		50	711-494		Spacer	
6	—		Engine		51	712-123		Hex Nut 5/16-24 Thd.*	
7	710-289		Hex Scr. 1/4-20 x .50" Lg.*		52	11130—474		Adapter Plate	
8	736-222		Extr. L-Wash. 1/4" Scr.*		53	10459		Reinforcement Plate	
9	10913—474		Drive Cover		54	712-107		Hex Centerlock Nut 1/4-20 Thd.	
10	714-365		Hi-Pro Key*		55	11141—474		Chute Deflector	
11	736-300		Flat Washer		56	732-253		Torsion Spring	
12	712-116		Elastic Locknut 3/8-24 Thd.*		57	7006		Fortiflex Bearing—Rear	
13	748-227		Hex Bearing		58	738-213		Axle Bolt—Rear Only	
14	716-106		"E" Ring 3/8 Shaft		59	710-567		Hex Scr. 1/4-28 x .62 Lg.	
15	10914		Drive Pinion		60	9392-501		Rear Wheel—Complete	
16	2265		Sleeve		61	736-105		Belleville Washer	
17	103/2—474		Drive Support		62	11802		Handle Mount Bracket	
18	716-106		"E" Ring 3/8 Shaft		63	714-104		Hairpin Cotter*	
19	736-116		Flat Washer		64	11193—474		Rear Pro. Shield Ass'y.—Comp.	
20	748-227		Hex Bearing		65				
21	715-247		Roll Pin 3/16 Dia. x 1" Lg.*		66	712-107		Hex Center L-Nut 1/4-20 Thd.*	
22	103/8		Sprocket Ass'y.		67	746-229		Conduit and Wire	
23	713-135		Chain w/Master Link No. 48 26" Lg.		68	746-128		Cable Clip	
24	738-147		Shoulder Bolt—Special		69	712-107		Hex Center L-Nut 1/4-20 Thd.*	
25	711-435		Shaft		70	710-606		Hex Scr. 1/4-20 x 1.50" Lg.*	
26	12119		Clutch Rod Ass'y.		71	9354		Upper Handle	
27	732-209		Extension Spring		72	710-606		Hex Hd. Cap Scr. 1/4-20 x 1 1/2" Lg.	
28	11801		Handle Mount Bracket—L.H.		73	7861		Control Clamp	
29	732-433		Tension Spring		74	712-526		Speed Nut	
30	9392-503		Front Wheel Complete		75	720-157		Grip—Black	
31	11430—474		Deck Ass'y.		76	710-192		Truss Mach. Scr. No. 10-24 x .38" Lg.	
32	712-123		Hex Nut 5/16-24 Thd.*		77	710-407		Slot Hex Hd. Self Extr. Scr. No. 8-32 x 1/2" Lg.	
33	736-119		Spring L-Wash. 5/16 Scr.*		78	11604		Handle Panel	
34	10769		Blade Adapter Kit		79	710-158		Hex Hd. Cap Scr. 5/16-24 x 1 1/4" Lg.*	
35	736-217		Spring L-Wash. 3/8 Scr.—H.D.*		80	10377		Sprocket Ass'y.	
36	710-459		Hex Hd. Cap Scr. 3/8-24 x 1 1/2" Lg.—H.T.		81	748-183		Bearing Support	
37	710-117		Hex Hd. Cap Scr. 5/16-24 x 1" Lg.—H.T.		82	10381		Engine Bracket Ass'y.	
38	10769		Blade Adapter Kit/Less Blade		83	736-222		External L-Wash. 1/4" Scr.*	
39	742-125		Blade—22 inch		84	710-230		Hex Hd. Cap Scr. 1/4-28 x 1/2"*	
40	736-105		Belleville Washer		85	11240—474		Pivot Plate Ass'y.	
41	748-125		Sintered Bearing—Front		86	714-104		Internal Cotter Pin	
42	738-129		Axle Bolt—Front Only		87	711-550		Ferrule	
43	736-160		Flat Washer						
44	10379		Link Ass'y.						
45	712-107		Hex Center L-Nut 1/4-20 Thd.*						

*For faster service obtain standard nuts and bolts locally. If these items cannot be obtained locally, order by part number and size as shown on the parts list.

When ordering parts, if color or finish is important use the appropriate color code shown above

The engine is not under warranty by the mower manufacturer. If repairs or service is needed on the engine, please contact your nearest authorized engine service outlet. Check the "Yellow Pages" of your telephone book under "Engines—Gasoline."

Find It Fast
In The
'Yellow Pages'



PARTS INFORMATION

DEFECTIVE OR MISSING PARTS must be reported to the factory immediately. Such claims must include your model number and date of purchase.

POWER EQUIPMENT PARTS AND SERVICE

Parts and service for all MTD manufactured power equipment are available through the authorized service firms listed below. All orders should specify the model number of your unit, parts numbers, description of parts and the quantity of each part required.

BRIGGS & STRATTON, TECUMSEH AND PEERLESS PARTS AND SERVICE

Briggs & Stratton, Tecumseh and Peerless parts and service should be handled by your nearest authorized engine service firm. Check the yellow pages of your telephone directory under the listing *Engines—Gasoline*, Briggs & Stratton or Tecumseh Lauson—Power Products.

A 1 Engine & Mower Co.

327 East 9th Street
Salt Lake City, Utah 84102

American Electric Ignition Co.

124 N. W. 8th Street
Oklahoma City, Oklahoma 73102

Auto Electric & Carburetor Co.

2525 4th Avenue, S.
P. O. Box 1948
Birmingham, Alabama 35233

Automotive Equipment Service Co.

3117 Holmes Street
Kansas City, Missouri 64109

Bailey's Rebuild Inc.

1325 E. Madison Street
Seattle Washington 98102

Bleckrie, Inc.

7900 Lorain Avenue
Cleveland, Ohio 44102

Brown Equipment Distributor Inc.

110 Beech Street
Corydon, Indiana 47112

Bullard Supply

2409 Commerce Street
Houston, Texas 77003

Carl A. Anderson Co.

623 S. 16th Street
Omaha, Nebraska 68102

Catto & Putty, Inc.

P. O. Box 2408
510 Soledad Street
San Antonio, Texas 78205

Center Supply Company

6867 New Hampshire Avenue
Takoma Park, Maryland 20012

Dixie Sales Company

P. O. Box 1408
327 Battleground Avenue
Greensboro, North Carolina 27402

East Point Cycle & Key Shop

1617 Whiteway
East Point, Georgia 30044

Gamble Distributors

West End Avenue
Carthage, New York 13619

Garden Equipment Co., Inc.

6600 Cherry Avenue
Long Beach, California 90805

Gardenville Supply, Inc.

Pipersville, Pennsylvania 18947

Henry W. O'Neil & Assoc., Inc.

410 North Goodman Street
Rochester, New York 14609

Henzler, Inc.

2015 Lemay Ferry Road
St. Louis, Missouri 63125

Kenton Supply

8216 North Denver Avenue
Portland, Oregon 97217

Kimber's Inc.

115 W. Geddes St.
Syracuse, New York 13204

The Lawnmower Shop

1340 El Camino Real
San Carlos, California 94070

Marr Brothers

423 E. Jefferson
Dallas, Texas 75203

Mathews Auto Electric Co.

420 East 2nd Street
Tulsa Oklahoma 74120

McClure Lawn & Garden Supply

1114 Lexington Avenue
Mansfield, Ohio 44907

Memphis Cycle & Supply Co.

421 Monroe Avenue
Memphis Tennessee 38103

Morton B. Collins Co.

300 Birnie Avenue
Springfield, Massachusetts 01107

Moz-All of Florida, Inc.

365 Greco Avenue
Coral Gables, Florida 33146

National Central, Div. of

Joe Sterling, Inc.
Drawer "D" 687 Seville Rd.
Wadsworth, Ohio 44281

Parts & Sales Inc.

2101 Industrial Pkwy.
Elkhart, Indiana 46514

Power Equipment Distributor

36463 So. Gratiot Avenue
Mt. Clemens, Michigan 48043

Power Lawn & Garden Equip. Co.

2551-2571 J. F. Kennedy Road
Dubuque, Iowa 52001

Radco Distributors

2403 Market Street
P. O. Box 3216
Jacksonville, Florida 32206

Raub Supply Company

James & Mulberry Sts.
Lancaster, Pennsylvania 17604

Richmond Battery & Ignition

P. O. Box 25369 — 957 Myers St.
Richmond, Virginia 23260

Smith Hardware Company

515 N. George Street
Goldsboro, North Carolina 27530

South Denver Lawn Equip. Co.

527 West Evans
Denver, Colorado 80223

Suhren Engine

8330 Earhart Blvd.
New Orleans, Louisiana 70118

Sutton's Lawn Mower Shop

Route 4, Box 343
North Little Rock, Arkansas 72117

Warner Equipment

7520 Lyndale Avenue, So.
Minneapolis, Minnesota 55423

Woodson Sales & Service

1702 North Sylvania
Ft. Worth, Texas 76111

WARRANTY PARTS AND SERVICE POLICY

The purpose of warranty is to protect the customer from defects in workmanship and materials, defects which are NOT detected at the time of manufacture. It does not provide for the unlimited and unrestricted replacement of parts. Use and maintenance are the responsibility of the customer. The manufacturer cannot assume responsibility for conditions over which it has no control. Simply put, if it's the manufacturer's fault, it's the manufacturer's responsibility; if it's the customer's fault, it's the customer's responsibility.

CLAIMS AGAINST THE MANUFACTURER'S WARRANTY INCLUDES

1. Replacement of Missing Parts on new equipment.
2. Replacement of Defective Parts within the warranty period.
3. Repair of Defects within the warranty period.

All claims MUST be substantiated with the following information:

1. Model Number of unit involved.
2. Date unit was purchased or first put into service.
3. Date of failure.
4. Nature of failure.