

OWNER'S GUIDE

• ASSEMBLY • OPERATION • MAINTENANCE • PARTS •



Model 118R Shown

21" SELF-PROPELLED MULCHING ROTARY MOWERS

Model Numbers
122-115R000
122-118R000

IMPORTANT!

Record the **Model No.** and **Mfg. Code** which appear on your unit in the space below. You **must** have these numbers, along with the date of purchase, in order to receive warranty or service.

MEETS ANSI SAFETY STANDARDS

MODEL NO.

MFG. CODE

**Important:
Read Safety Rules
and Instructions Carefully**



Made
in
AMERICA

WARNING: This unit is equipped with an internal combustion engine and should not be used on or near any unimproved forest-covered, brush-covered or grass-covered land unless the engine's exhaust system is equipped with a spark arrester meeting applicable local or state laws (if any). If a spark arrester is used, it should be maintained in effective working order by the operator.

In the State of California the above is required by law (Section 4442 of the California Public Resources Code). Other states may have similar laws. Federal laws apply on federal lands. A spark arrester for the muffler is available through your nearest engine authorized service dealer or contact the service department, P.O. Box 360900, Cleveland, Ohio 44136.

IMPORTANT

RULES FOR SAFE OPERATION



THIS SYMBOL POINTS OUT IMPORTANT SAFETY INSTRUCTIONS WHICH, IF NOT FOLLOWED, COULD ENDANGER THE PERSONAL SAFETY AND/OR PROPERTY OF YOURSELF AND OTHERS. READ AND FOLLOW ALL INSTRUCTIONS IN THIS MANUAL BEFORE ATTEMPTING TO OPERATE YOUR LAWN MOWER. FAILURE TO COMPLY WITH THESE INSTRUCTIONS MAY RESULT IN PERSONAL INJURY. WHEN YOU SEE THIS SYMBOL—



HEED ITS WARNING.



DANGER

Your lawn mower was built to be operated according to the rules for safe operation in this manual. As with any type of power equipment, carelessness or error on the part of the operator can result in serious injury. If you violate any of these rules, you may cause serious injury to yourself or others.



TRAINING

1. Read this owner's guide carefully in its entirety before attempting to assemble or operate this machine. Be completely familiar with the controls and the proper use of this machine before operating it. Keep this manual in a safe place for future and regular reference and for ordering replacement parts.
2. Your rotary mower is a precision piece of power equipment, not a plaything. Therefore, exercise extreme caution at all times.
3. Never allow children to operate a power mower. Only persons well acquainted with these rules of safe operation should be allowed to use your mower.
4. Keep the area of operation clear of all persons, particularly small children and pets. Stop engine when they are in the vicinity of your mower to help prevent blade contact or thrown object injury. Although the area of operation should be completely cleared of foreign objects, an object may have been overlooked and could be accidentally thrown by the mower in any direction and cause serious personal injury to the operator or any others allowed in the area.



PREPARATION

1. Thoroughly inspect the area where the equipment is to be used. Remove all stones, sticks, wire, bones and other foreign objects which could be picked up and thrown by the mower in any direction and cause serious personal injury to the operator or any others allowed in the area.
2. Always wear safety glasses or eye shields during operation or while performing an adjustment or repair, to protect eyes from foreign objects that may be thrown from the machine in any direction.
3. Wear sturdy, rough-soled work shoes and close-fitting slacks and shirts to avoid entanglement in the moving parts. Never operate a unit in bare feet, sandals, or sneakers.
4. Check the fuel before starting the engine. Gasoline is an extremely flammable fuel. Do not fill the gasoline tank indoors, while the engine is running, or until engine has been allowed to cool for two minutes after running. Replace gasoline cap securely and wipe off any spilled gasoline before starting the engine as it may cause a fire or explosion.
5. Disengage the self-propelled mechanism or drive clutch on units so equipped before starting the engine.
6. The blade control handle is a safety device. Never attempt to bypass its operation. Doing so makes the safety device inoperative and may result in personal injury through contact with the rotating blade. The blade control handle must operate easily in both directions.
7. Never attempt to make a wheel or cutting height adjustment while the engine is running.
8. Never operate the equipment in wet grass. Always be sure of your footing. A slip and fall can cause serious personal injury. Keep a firm hold on the handle and walk, never run. Mow only in daylight or in good artificial light.

9. For your safety, use the slope gauge included as part of this manual to measure slopes before operating this unit on a sloped or hilly area. If the slope is greater than 15° as shown on the slope gauge, do not operate this unit on that area or serious injury could result.



OPERATION

1. Do not change the engine governor settings or overspeed the engine. Excessive engine speeds are dangerous.
2. Do not put hands or feet near or under rotating parts. Keep clear of the deck at all times as the rotating blade can cause injury.
3. Stop the blade when crossing gravel drives, walks or roads.
4. After striking a foreign object, stop the engine, remove the wire from the spark plug, and thoroughly inspect the mower for any damage. Repair the damage before restarting and operating the mower.
5. If the equipment should start to vibrate abnormally, stop the engine and check immediately for the cause. Vibration is generally a warning of trouble.
6. Shut the engine off and wait until the blade comes to a complete stop before performing any work on the mower. The cutting blade continues to rotate for a few seconds after the engine is shut off. Never place any part of the body in the blade area until you are sure the blade has stopped rotating.
7. Before cleaning, repairing or inspecting, make certain the blade and all moving parts have stopped. Disconnect the spark plug wire, and keep the wire away from the spark plug to prevent accidental starting.
8. Do not run the engine indoors.
9. Mow across the face of slopes, never up-and-down. Exercise extreme caution when changing direction on slopes. Do not mow excessively steep slopes. Always be sure of your footing. A slip and fall can cause serious personal injury.
10. Never operate mower without proper guards, plates or other safety protective devices in place.



MAINTENANCE AND STORAGE

1. Check the blade and engine mounting bolts at frequent intervals for proper tightness.
2. Keep all nuts, bolts, and screws tight to be sure the equipment is in safe working condition.
3. Never store the equipment with gasoline in the tank inside of a building where fumes may reach an open flame or spark. Allow the engine to cool before storing in any enclosure.
4. To reduce fire hazard, keep the engine free of grass, leaves, or excessive grease.

USE THIS SHEET AS A GUIDE TO DETERMINE SLOPES WHERE YOU MAY NOT OPERATE SAFELY.

SLOPE GAUGE

(Keep this sheet in a safe place for future reference.)

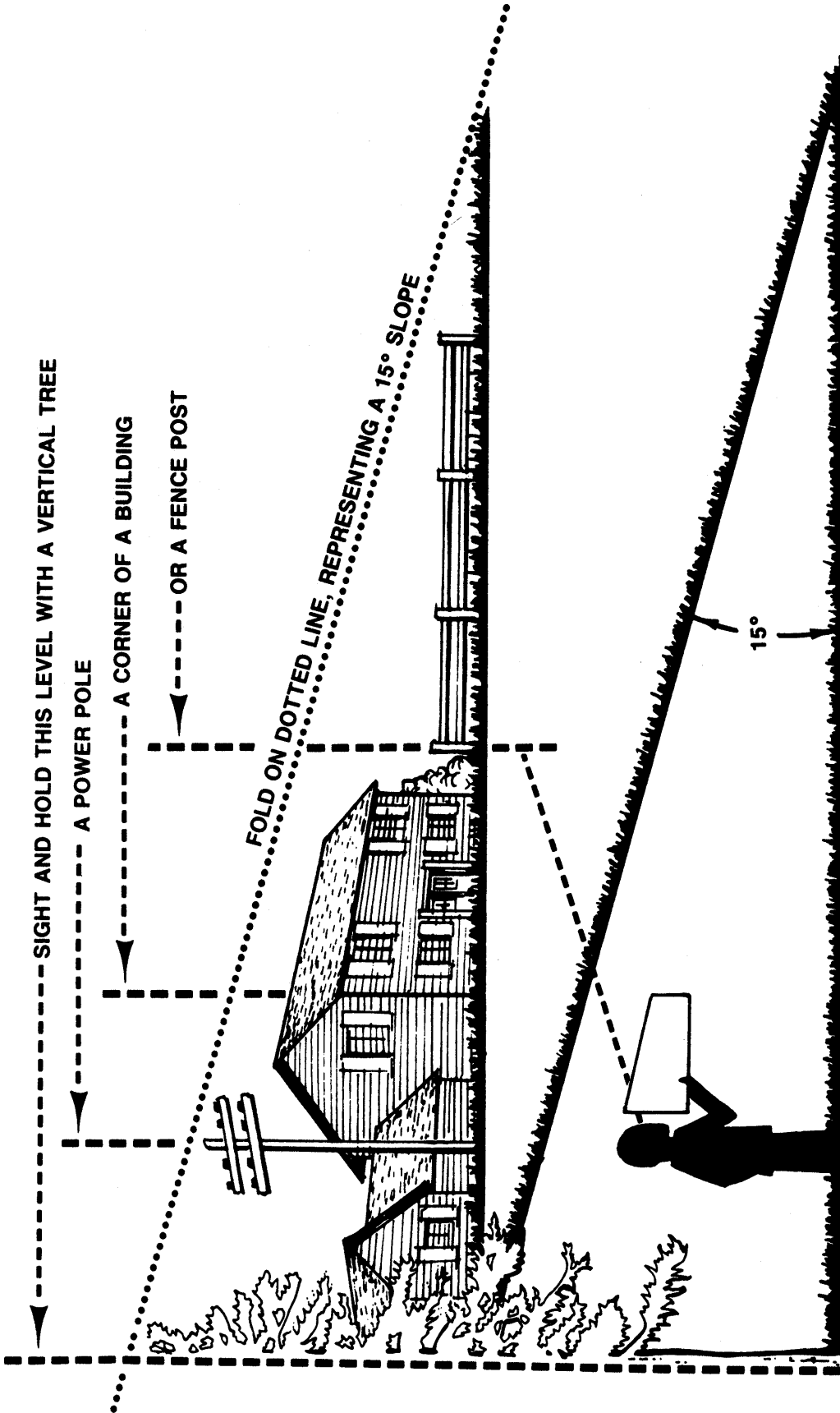

Do not mow on inclines with a slope in excess of 15 degrees (a rise of approximately 2-1/2 feet every 10 feet). A riding mower could overturn and cause serious injury. If operating a walk-behind mower on such a slope, it is extremely difficult to maintain your footing and you could slip, resulting in serious injury.

Operate RIDING mowers up and down slopes, never across the face of slopes.
Operate WALK-BEHIND mowers across the face of slopes, never up and down slopes.

CONTENTS OF HARDWARE PACK/PARTS IDENTIFICATION

Remove this sheet from your owner's manual and lay the hardware on the illustration for identification purposes. After assembly, keep the Slope Gauge which is on the reverse side of this sheet for future use.

(Hardware pack may contain extra items which are not used on your unit.—Part numbers are shown in parentheses.)

A ATTACHING THE LOWER HANDLE

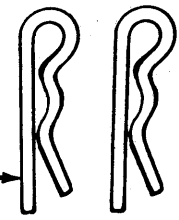

Hairpin Clips (714-0104)

B ATTACHING THE UPPER HANDLE

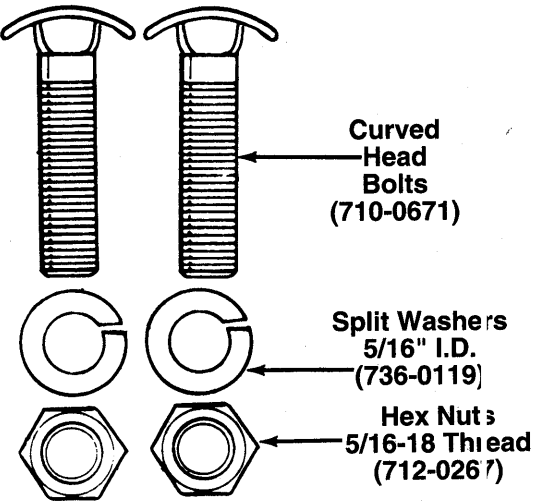

Curved Head Bolts (710-0671)

Split Washers 5/16" I.D. (736-0119)

Hex Nuts 5/16-18 Thread (712-0267)

C ATTACHING THE DRIVE CLUTCH CONTROL CABLE

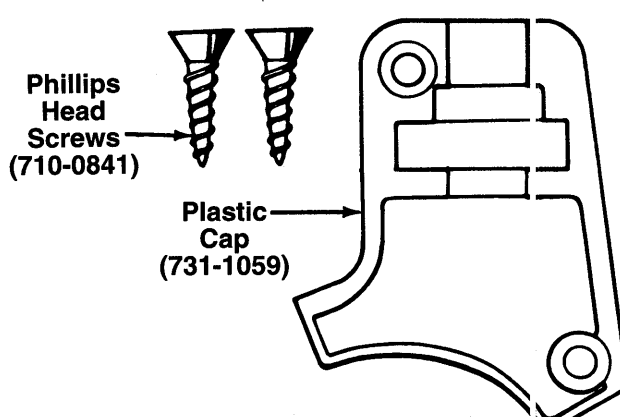

Phillips Head Screws (710-0841)

Plastic Cap (731-1059)

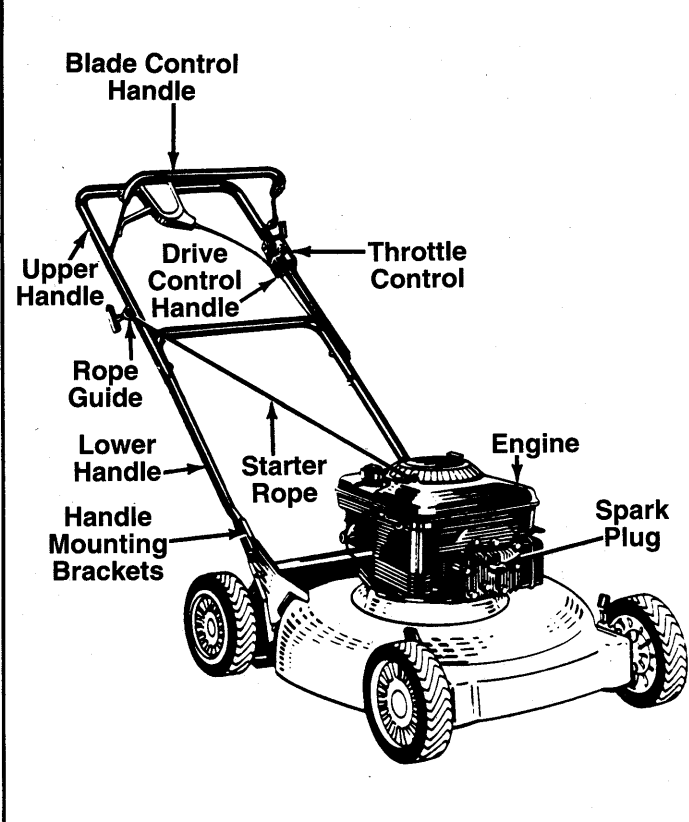

Blade Control Handle

Upper Handle

Drive Control Handle

Throttle Control

Rope Guide

Lower Handle

Starter Rope

Engine

Spark Plug

Handle Mounting Brackets

PARTS IDENTIFICATION

D ATTACHING THE STARTER ROPE

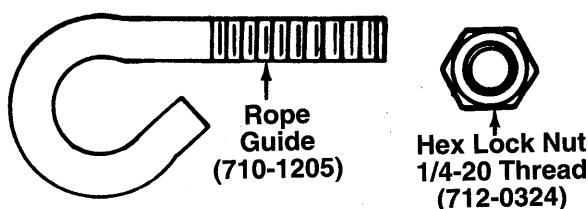

Rope Guide (710-1205)

Hex Lock Nut 1/4-20 Thread (712-0324)

E SECURING THE CABLES

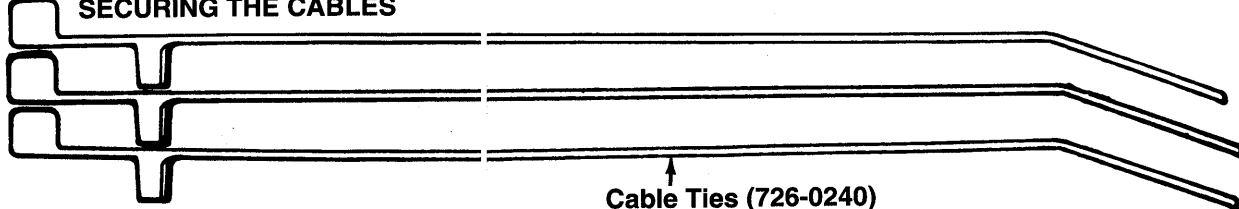

Cable Ties (726-0240)

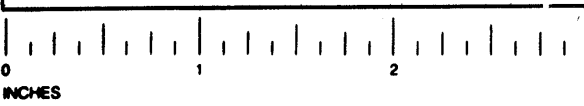

Cut Along This Line

ASSEMBLY INSTRUCTIONS

IMPORTANT: This unit is shipped **WITHOUT GASOLINE or OIL.** After assembly, service engine with gasoline and oil as instructed in the separate engine manual packed with your unit.

NOTE: Reference to right or left hand side of the mower is observed from the operating position. Refer to parts identification on page 4 for location of parts when assembling the mower.

Tools Required for Assembly

- (1) Pair of Pliers
- (1) 1/2" Wrench or Adjustable Wrench
- (1) Phillips Screwdriver

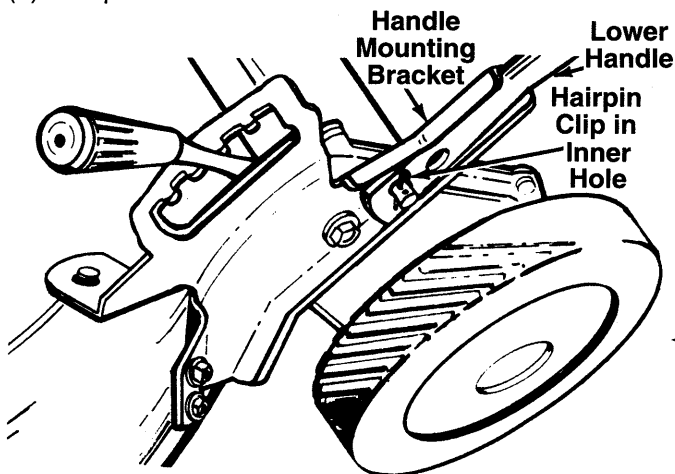

FIGURE 1.

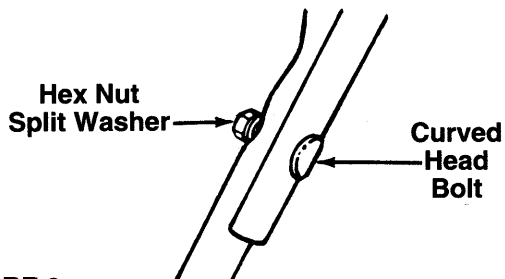

FIGURE 2.

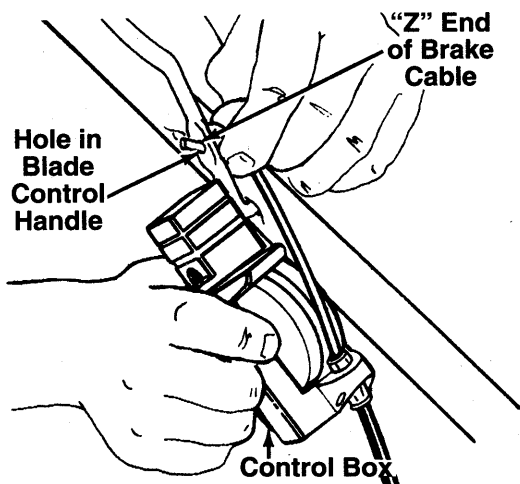

FIGURE 3.

UNPACKING

1. Remove the lawn mower from the carton by opening the top flaps and lifting the unit out. Be careful of the staples. Make certain all parts and literature have been removed from the carton before the carton is discarded.
2. Disconnect the spark plug wire and move away from the spark plug.
3. Stretch out all control cables behind the mower and place on the floor. Be careful not to bend or kink the cables at any time during assembly.
4. Remove page four from this manual and lay the contents of the hardware pack on the illustration for identification.

ATTACHING THE LOWER HANDLE (Hardware A)

1. Attach the lower handle by placing the bottom holes in the lower handle over the weld pins on the handle mounting brackets on the rear of the deck.
2. Using a pair of pliers, squeeze one leg of the lower handle against the handle mounting bracket. Insert the hairpin clip into the inner hole in the weld pin. See figure 1. Repeat on other side.

NOTE: There are two (2) holes in the handle mounting brackets. Place the hairpin clip in the inner hole for operation. Outer hole is for storage.

ATTACHING THE UPPER HANDLE (Hardware B)

1. Place the upper handle in position over the lower handle. The throttle control (attached to the upper handle) must be on the **left** side.
2. Secure the upper handle to the lower handle using the curved head bolts, split washers and hex nuts as shown in figure 2.

ATTACHING THE CONTROL BOX

← One end of the throttle control cable and the brake cable is attached to the engine. The other end is attached to the control box. Attach the control box to the upper handle as follows.

1. Remove the truss machine screw and hex lock nut from the middle of the control box using a phillips screwdriver. Hold your finger over the hex lock nut so it stays inside the control box so you can unscrew the truss machine screw.
2. Make certain the blade control handle is on **top** of the upper handle.
3. Route the control box (with cables attached) under the lower handle. Make certain the cables are not twisted. Hold the control box near the left side of the upper handle (control box must be inside the handle).

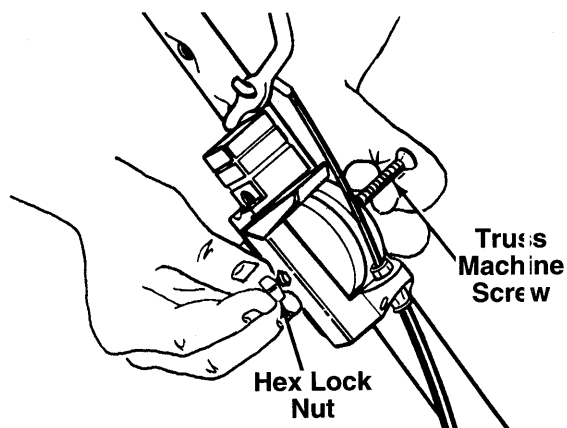

FIGURE 4.

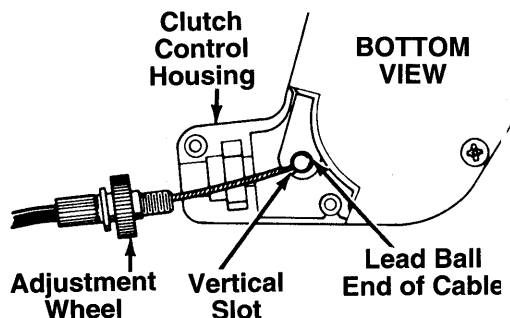

FIGURE 5.

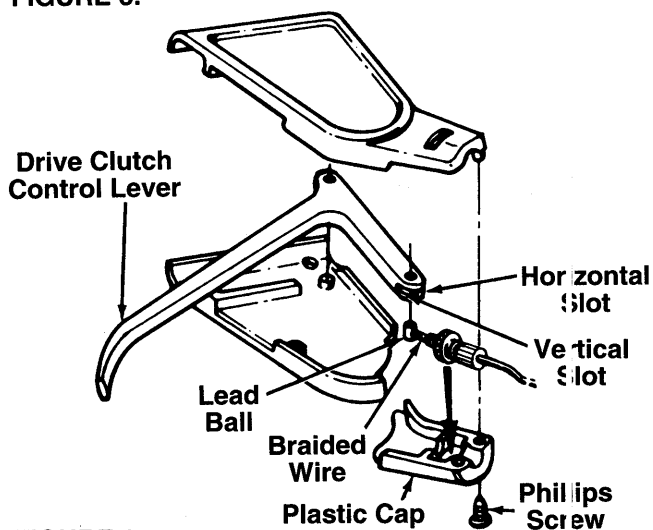

FIGURE 6.

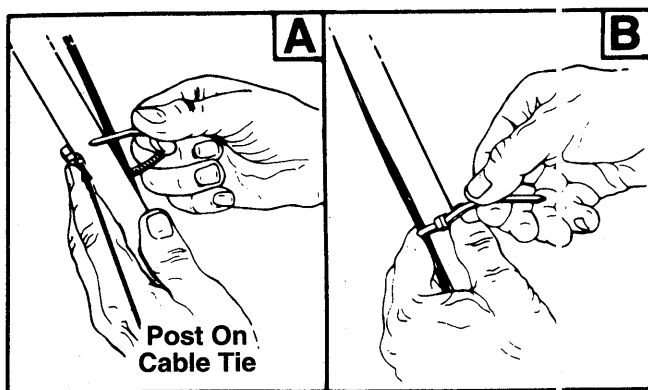

FIGURE 7.

4. Hook the "Z" end of the brake cable into the control handle from the **outside** to the **inside**. See figures 3 and 4.
5. Place the control box on the upper handle just below the end of the control handle as shown in figure 4. Secure with hardware removed in step one by placing hex lock nut into the indent on the inside of the control box. Screw the truss machine screw into the hex lock nut.

ATTACHING THE DRIVE CLUTCH CONTROL CABLE (Hardware C)

The drive clutch control cable is attached to the deck. Route the cable under the lower handle. Attach the cable to the lever in the clutch control housing, located in the middle of the upper handle, as follows.

1. Place the lead ball end of the cable into the fitting provided in the end of the clutch control lever. Slip the braided wire into the vertical slot as shown in figure 5.
2. Slide the braided wire around in the horizontal slot. See figure 6.
3. Make certain the adjustment wheel is threaded onto the cable as far as possible as shown in figure 5. Place the adjustment wheel into the clutch control housing.
4. Secure the plastic cap to the clutch control housing using the two Phillips head screws. See figure 6.



WARNING: Drive clutch adjustment must be checked before the unit is operated, as described in the Operation Section.

SECURING THE CABLES (Hardware E)

Secure all cables to the left side of the handle as follows.



WARNING: When attaching the control cables, the cables must be routed to avoid contact with all sharp edges and hot surfaces to prevent damage to the cables, which will render the controls inoperative.

1. Insert posts on cable ties into holes provided on the handles, one on the upper handle and two on the lower handle. The holes may be either on the inside or outside of the handles. See figure 7A.
2. Secure the cables with the cable ties, making certain the cables do not contact the wheel. See figure 7B. Trim excess ends of cable ties.

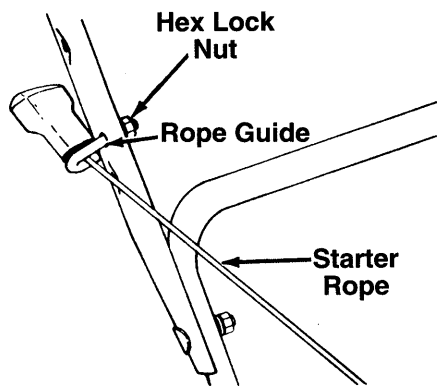

FIGURE 8.

ATTACHING THE STARTER ROPE (Hardware D)

1. The starter rope is inside the top of the engine. Additional rope may be wound around the starter handle. If so, unwind the rope from the handle.
2. With the spark plug wire disconnected and grounded, depress the blade control handle and pull the rope out of the engine.
3. Place the rope guide around the starter rope, so the rope guide bends downward as shown in figure 8. Insert the rope guide into the handle, and secure with hex lock nut.

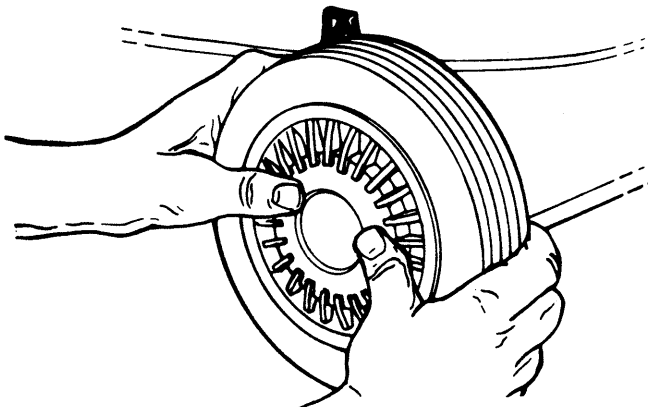

FIGURE 9.

FINAL ASSEMBLY OF MOWER

1. Attach hub caps (optional) to wheels by placing in position against the inner hub of the wheel. For units with 2" wide tires, press firmly around the center portion of hub cap in a circular motion, similar to installing a lid on a round, plastic container. See figure 9. The hub caps are flexible and will snap over the wheel hubs.

NOTE: It may be helpful to place the hub caps in hot tap water for several minutes to make them pliable before installing, especially if the temperature is less than 60° F.

2. Make certain all nuts and bolts are tightened securely.

CONTROLS

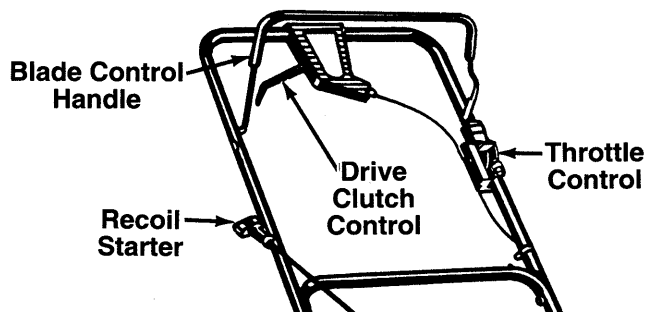

FIGURE 10.

BLADE CONTROL HANDLE



WARNING: This control mechanism is a safety device. Never attempt to bypass its operations.

The blade control handle is located on the upper handle of the mower. See figure 10. The blade control handle must be depressed in order to operate the unit. Release the blade control handle to stop the engine and blade.



WARNING: The blade will be rotating whenever the engine is running.

THROTTLE CONTROL

The throttle control is located on the side of the upper handle. It is used to regulate the engine speed.



WARNING: The throttle control cannot be used to stop the engine.

RECOIL STARTER

The recoil starter handle is attached to the handle. See figure 10. Stand behind the unit in the operating position to start the unit.

DRIVE CLUTCH CONTROL

Squeezing the drive clutch control engages the drive mechanism to the rear wheels. Releasing the clutch control stops the rear wheels from driving. Release the drive clutch control to slow down when negotiating an obstacle, making a turn or stopping. See figure 10.

OPERATION



FIGURE 11.

Keep hands and feet away from the mowing deck. See figure 11.

The operation of any lawn mower can result in foreign objects being thrown into the eyes, which can result in severe eye damage. Always wear safety glasses or eye shields. We recommend wide vision safety mask for over spectacles or standard safety glasses.



NOTE: For shipping purposes your mower is set with the wheels in a low cutting height position. For best results raise the cutting position until it is determined which height is best for your lawn. See cutting height adjustment section.

GAS AND OIL FILL-UP

Service the engine with gasoline and oil as instructed in the separate engine manual packed with your mower. Read instructions carefully.



WARNING: Never fill fuel tank indoors, with engine running or until the engine has been allowed to cool for at least two minutes after running.

BEFORE STARTING

1. Attach spark plug wire to spark plug. Make certain the metal loop on the end of the spark plug wire (inside the rubber boot) is fastened securely over the metal tip on the spark plug. See figure 12.

Metal Loop
on Spark
Plug Wire

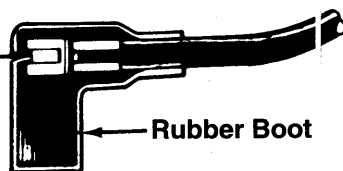

FIGURE 12.

2. Before each use, check for proper drive clutch operation by performing the following before starting the engine:

With the drive clutch control released, push mower forward. It should move freely. Pull mower backward. It should move with only a small amount of resistance (no more than 15 lbs. pressure).

If it does not and the rear wheels tend to lock up, the clutch may not be releasing completely. Do not start the engine until corrections have been made. Check the control cable for severe bend, kinks and binding, or grass build-up around the belt. Correct and adjust as required. Refer to instructions under "Drive Clutch Control Adjustment" in Adjustment Section for loosening the drive belt.

TO START ENGINE AND ENGAGE BLADE



WARNING: When starting the unit for the first time, face the mower against a solid object such as a wall, fence, etc. Start the unit, and if it shows any signs of motion with the drive clutch control disengaged, shut the engine off immediately. Make certain the drive clutch control is adjusted so the drive belt is as loose as possible. Refer to the Adjustment Section.

1. Move throttle control lever all the way forward.
2. If engine is equipped with a primer, prime engine as instructed in separate engine manual.
3. Standing behind the unit, depress the blade control handle and hold it against the upper handle as shown. See figure 13.
4. Grasp the recoil starter handle and pull back rapidly, extending rope fully. Return it slowly to the rope guide.
5. After engine starts, move throttle control to desired engine speed.

NOTE: If any problems are encountered, refer to the Trouble Shooting Guide on page 16.

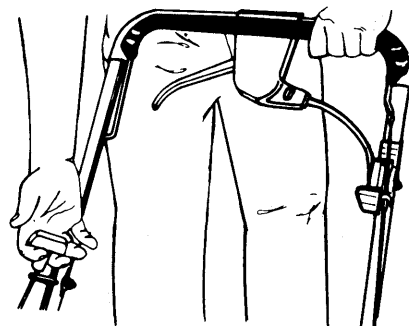

FIGURE 13.

TO STOP ENGINE AND BLADE

1. Move throttle control lever to SLOW position.
2. Release the blade control handle to stop the engine and blade.



WARNING: The blade continues to rotate for a few seconds after the engine is shut off.

3. Disconnect the spark plug wire and ground it against the engine to prevent accidental starting while equipment is unattended.

USING YOUR ROTARY MOWER

Be sure that lawn is clear of stones, sticks, wire, or other objects which could damage lawn mower or engine. Such objects could be accidentally thrown by the mower in any direction and cause serious personal injury to the operator and others.

For the best results, do not cut wet grass because it tends to stick to the underside of the mower, preventing proper mulching of grass clippings. In addition, wet grass could cause you to slip and fall. New grass, thick grass or wet grass may require a narrower cut.

For best results, cut off one-third or less of the total length of the grass. Lawn should be cut in the fall as long as there is growth.

This mower is designed to be operated at full throttle to give you the best cut and do the most effective job of mulching.



WARNING: If you strike a foreign object, stop the engine. Remove wire from spark plug, thoroughly inspect the mower for any damage, and repair the damage before restarting and operating the mower. Extensive vibration of the mower during operation is an indication of damage. The unit should be promptly inspected and repaired.

ADJUSTMENTS



WARNING: Do not at any time make any adjustment to lawn mower without first stopping engine and disconnecting spark plug wire.

CUTTING HEIGHT ADJUSTMENT

The height adjustment handles for the wheels are located on the left side of the deck. The handles may be placed in one of nine cutting height positions. See figure 14.

For rough or uneven lawns, move the height adjustment handles to positions which will give a higher cutting height. Both front and rear handles must be placed in the same relative position.

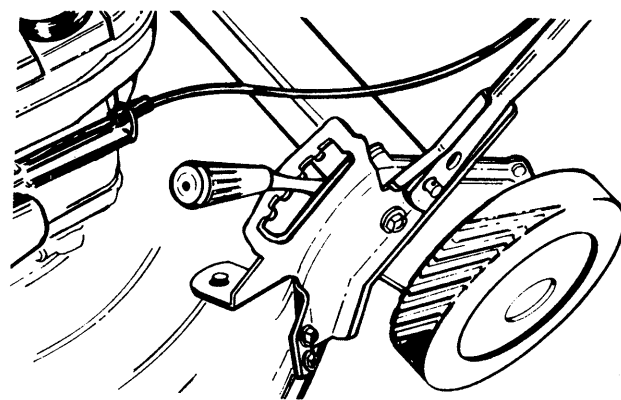

FIGURE 14.

DRIVE CLUTCH CONTROL ADJUSTMENT

Use the adjustment wheel located in the clutch control housing to tighten the drive belt if mower does not self-propel with the drive clutch control engaged, or if drive belt is slipping (unit hesitates while engine maintains the same speed). See figure 15.

In addition, the adjustment wheel may also be used to determine the position in which the drive clutch control is engaged. If it is more comfortable to have the drive engaged with the lever further away from the handle, tighten the drive belt.

Make certain to retest the unit for neutral as instructed in the Operation Section. Move the adjustment wheel in the opposite direction to loosen the drive belt if necessary.

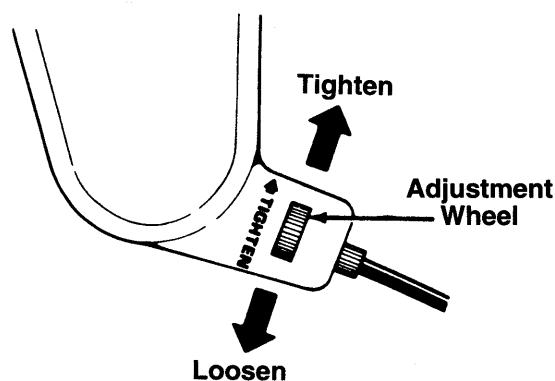

FIGURE 15.

THROTTLE CONTROL ADJUSTMENT

If the throttle control requires adjustment or if it has been replaced, adjust the throttle control as follows.

1. Remove the screw shown in figure 16. Remove the cable clamp from the cable.

NOTE: If you have a Tecumseh engine, simply loosen the screw shown in figure 16B so the cable will move freely beneath the clamp. It is not necessary to remove the screw and clamp completely.

2. Push the throttle control lever on the handle all the way forward as far as it will go, then back it off one "click". Make certain the throttle control lever remains in this position.
3. Push the control lever on the engine as far toward the rear of the engine as it will go. Secure the cable in this position with the cable clamp and screw.

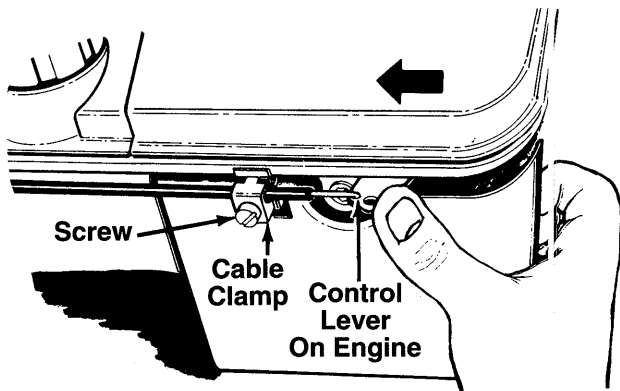

FIGURE 16A.—Briggs & Stratton Quantum Engines

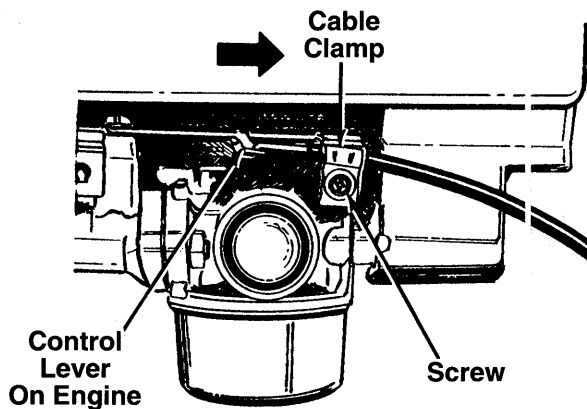

FIGURE 16B.—Tecumseh Engines

CARBURETOR ADJUSTMENTS



WARNING: If any adjustments are made to the engine while the engine is running (e.g. carburetor), keep clear of all moving parts. Be careful of heated surfaces and muffler.

Minor carburetor adjustments may be required to compensate for differences in fuel, temperature, altitude and load. To adjust carburetor, refer to the separate engine manual packed with your mower.

NOTE: A dirty air cleaner will cause an engine to run rough. Be certain air cleaner is clean and attached to the carburetor before adjusting carburetor. Refer to the separate engine manual.

LUBRICATION



WARNING: Always stop engine and disconnect spark plug wire before cleaning, lubricating or doing any kind of work on lawn mower.

Blade Control—Lubricate the pivot points on the blade control handle and the brake cable at least once a season with light oil. See figure 17. The blade control must operate freely in both directions.

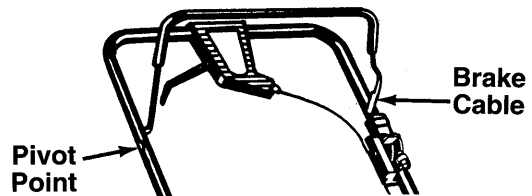

FIGURE 17.

Wheels—Mower may be provided with ball bearing wheels. Lubricate at least once a season with light oil. Also, if the wheels are removed for any reason, lubricate the surface of the axle bolt and the inner surface of the wheel with light oil. A 4 oz. plastic bottle of light oil lubricant is available. Order part number 737-0170. Engine oil may also be used.

Engine—Follow engine manual for lubrication instructions.

Transmission—The transmission is pre-lubricated and sealed at the factory. It does not require checking. If disassembled for any reason, fill with 2 ounces of Alvania grease, part number 737-0168.

MAINTENANCE



WARNING: Be sure to disconnect and ground the spark plug wire before performing any repairs or maintenance.

NOTE: When tipping the unit, empty the fuel tank and keep engine spark plug or muffler side up.

TROUBLE SHOOTING

Refer to page 16 of this manual for trouble shooting information.

CUTTING BLADE

When removing the cutting blade for sharpening or replacement, protect hands by using heavy gloves or a rag to grasp the cutting blade. Remove the bolt and bell washer which hold the blade and adapter to the engine crankshaft. Remove the blade and adapter from the crankshaft.

If the blade or blade adapter needs replacing, remove the two small bolts, lock washers and nuts which hold the blade to the adapter.



WARNING: Periodically inspect the blade adapter for cracks, especially if you strike a foreign object. Replace when necessary.

When sharpening the blade, follow the original angle of grind as a guide. It is extremely important that each cutting edge receives an equal amount of grinding to prevent an unbalanced blade. An unbalanced blade will cause excessive vibration when rotating at high speeds, may cause damage to the mower and could break, causing personal injury.

It is recommended that the blade always be removed from the adapter for the best test of balance.

The blade can be tested by balancing it on a round shaft screwdriver. Remove metal from the heavy side until it balances evenly.

Before reassembling the blade and the blade adapter to the unit, lubricate the engine crankshaft and the inner surface of the blade adapter with light oil. Lubricating the bolt holes, bolts and inner surface of the nuts with light oil is also recommended. A 4 oz. plastic bottle of light oil lubricant is available. Order part number 737-0170. Engine oil may also be used.

When replacing the blade, be sure to install the blade with the side of the blade marked "Bottom" (or with part number) facing the ground when the mower is in the operating position.

Blade Mounting Torque

Center Bolt: 450 in. lbs. min., 600 in. lbs. max.

Blade Adapter Bolts: 200 in. lbs. min., 350 in. lbs. max.

To insure safe operation of your unit, all nuts and bolts must be checked periodically for correct tightness.

DECK

The underside of the mower deck should be cleaned after each use to prevent a buildup of grass clippings, leaves, dirt or other matter. If this debris is allowed to accumulate, it will invite rust and corrosion, and may prevent proper mulching.

The deck may be cleaned by tilting the mower and scraping clean with a suitable tool (make certain the spark plug wire is disconnected).

ENGINE

Refer to the separate engine manual for engine maintenance instructions.

Service **air cleaner** every 25 hours under normal conditions. Clean every few hours under extremely dusty conditions. Poor engine performance and flooding usually indicates that the air cleaner should be serviced. To service the air cleaner, refer to the separate engine manual packed with your unit.

The **spark plug** should be cleaned and the gap reset once a season. Spark plug replacement is recommended at the start of each mowing season; check engine manual for correct plug type and gap specifications.

Clean the engine regularly with a cloth or brush. Keep the cooling system (blower housing area) clean to permit proper air circulation which is essential to engine performance and life. Be certain to remove all grass, dirt and combustible debris from muffler area.

BELT REMOVAL AND REPLACEMENT

1. Disconnect the spark plug wire and ground it against the engine.
2. Drain the fuel tank or place a piece of plastic beneath the cap to prevent gasoline leakage.
3. Remove the transmission belt cover by removing three bolts. See figure 18.

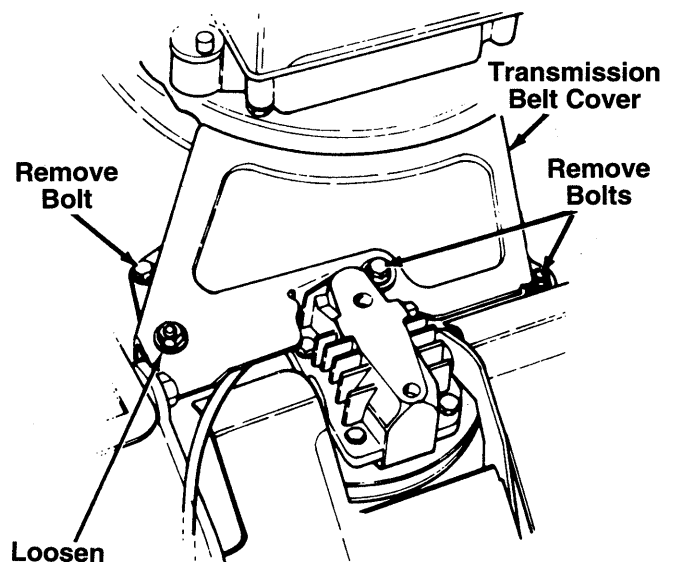

FIGURE 18.

4. Tip the mower back on its side. Block securely.
5. Remove the center bolt which secures the blade to the crankshaft. See figure 19. Remove the blade and blade adapter.
6. Remove the inside belt cover by removing three self-tapping screws and flat washers. A 3/8" wrench is required. See figure 19.

- Roll the belt over the pulley half and remove from around crankshaft.

NOTE: If the cupped washers and crankshaft spacer are removed for any reason, make certain they are reassembled as shown in figure 19, inset.

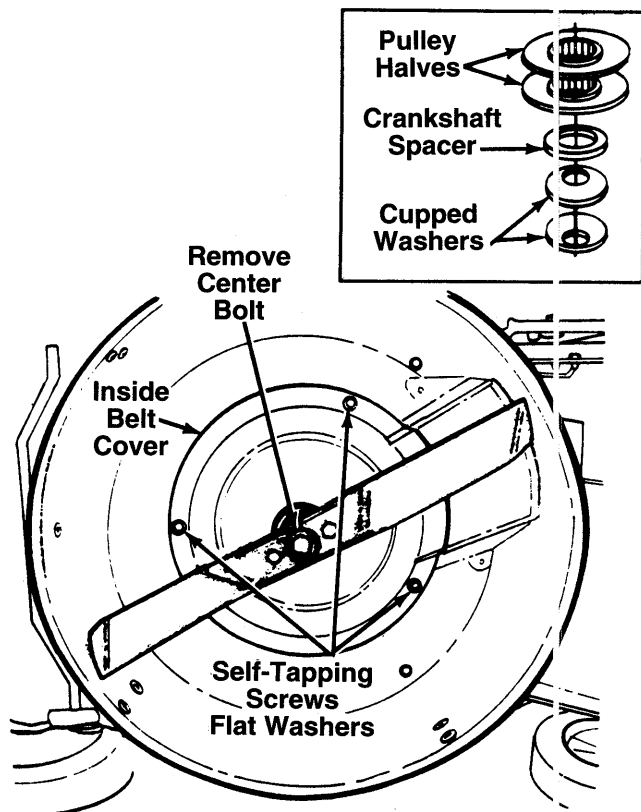

FIGURE 19.

- Remove the belt from between the idler pulley and the belt guard on the idler pulley bracket. See figure 20.

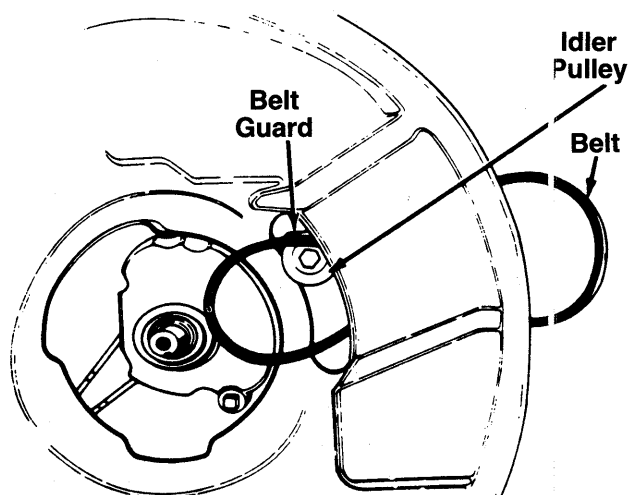

FIGURE 20.

- Remove the belt from the transmission pulley.
- Assemble the new belt as follows.
 - Push the idler pulley up out of the way as shown in figure 20.
 - Slide the belt in from the rear of the deck, and place it around the transmission pulley. See figure 20.
 - Release the idler pulley so it falls down into position. Slide the belt in between the idler pulley and belt guard on the idler pulley bracket.
 - Grease the crankshaft. Place belt between the two pulley halves, and reassemble the blade adapter and blade. Reassemble the inside belt cover.
 - Reassemble the transmission belt cover, following instructions in step 4 in reverse order.

NOTE: When reassembling the transmission belt cover, be certain the belt guard on the transmission cover is approximately 1/8" away from the belt. Make certain to tighten all nuts and bolts securely. If plastic was placed under the gas cap, be certain to remove it.

OFF-SEASON STORAGE

The following steps should be taken to prepare lawn mower for storage.

- Clean and lubricate mower thoroughly as described in the lubrication instructions.
- Refer to separate engine manual for correct engine storage instructions.
- Coat mower's cutting blade with chassis grease to prevent rusting.
- Store mower in a dry, clean area. Do not store next to corrosive materials, such as fertilizer.

NOTE: When storing any type of power equipment in an unventilated or metal storage shed, care should be taken to rust-proof the equipment. Using a light oil or silicone, coat the equipment, especially cables and all moving parts.

Models 115R and 118R

****FRONT WHEEL CHART**

Size	Tread	Part No.
8" x 1.75"	Bar Tread	634-0020
8" x 2"	"S" Wave	734-1513B (Silver)
8" x 2"	"S" Wave	734-1517B (Beige)

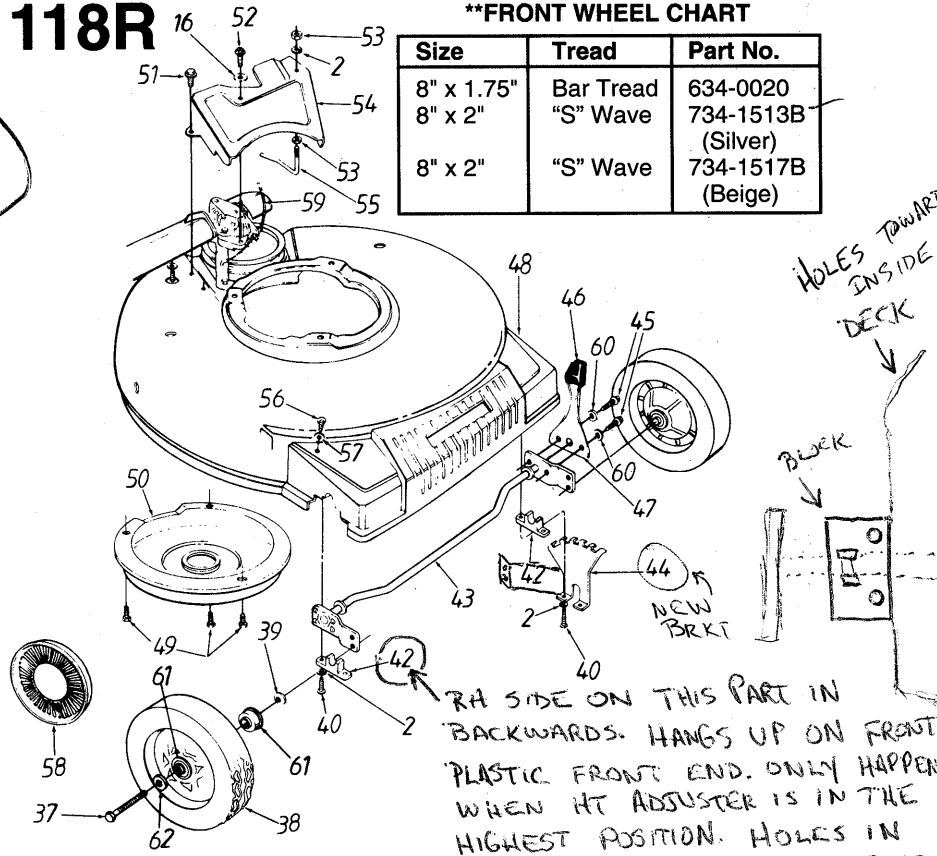
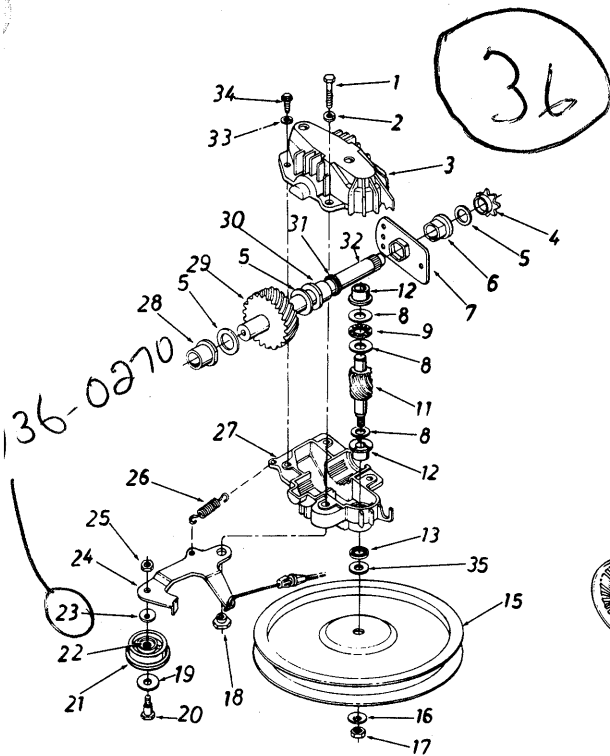

PARTS LIST FOR MODELS 115R AND 118R ROTARY MOWERS

REF. NO.	PART NO.	CODE	DESCRIPTION	REF. NO.	PART NO.	CODE	DESCRIPTION
1	710-1062		Hex Patch Bolt 1/4-20 x 1.25"†	33	736-0722		L-Wash. #10 I.D.†
2	736-0329		L-Wash. 1/4" I.D.*	34	710-0436		Hex B-Tap Scr. #10 x .62"†
3	717-0418A		Upper Hsg. Half†	35	736-0410		Hex Washer .26" x .88"
4	713-0400		#48 Sprocket 7 T x 1/2 Pitch†	36	717-0417B		Transmission Comp.
5	736-0336		FI-Wash. 5/8" I.D. x .030†	37	738-0102		Front Axle Bolt
6	741-0413		Hex Flange Brg. .631" I.D.†	38	**		Wheel Ass'y. Comp.
7	16500A		Hex Bearing Cup†	39	736-0105		Bell-Wash. .380" I.D. x .88
8	736-0314		Thrust Wash. .382" I.D. x .70" O.D.†	40	710-0588		Hex B-Tap Scr. 1/4-20
9	741-0479		Thrust Bearing .375" I.D. x .812" O.D.†	42	741-0492A		Block Bushing
11	717-1216		11 Tooth Pinion Shaft†	43	17733		Axle Ass'y.
12	748-0208A		Flange Bearing†	44	17059	782-0516	Height Adj. Bracket (NEW BRKT) RUNNING CHANGE
13	721-0212		Oil Seal†	45	710-0653		Hex TT-Tap Scr. 1/4-20 x .38"
15	756-0330A		FI-Pulley 5.06" O.D.	46	720-0190		Knob
16	736-0270		Bell-Wash. .265" I.D. x .75"	47	732-0639		Spring Lever
17	712-0351		Hex L-Nut 1/4-28 L.H. Thd.	48	731-1281		Plastic Front End
18	738-0440		Shld. Spacer .375" Dia. x .170	49	710-0352		Hex B-Tap Scr. 1/4" x .38"
19	736-0344		FI-Wash. .390" I.D. x 1.0"	50	782-7522		Belt Cover
20	738-0826		Shld. Bolt .375" Dia. x .40"	51	710-0599		Hex Wash. Hd. TT-Scr. 1/4-20
21	756-0558		FI-Idler Plastic 1.50" Dia.	52	710-0896		Hex Wash. Hd. B-Tap Scr. 1/4 x .62" (Spec.)
22	741-0556		Needle Brg. .375" x .31	53	712-0287		Hex Nut 1/4-20 Thd.*
24	17052A		Idler Brk't. Ass'y.	54	17058A		Transmission Belt Guard
25	712-0138		Hex Patch L-Nut 1/4-28 Thd.	55	747-0549		S.P. Belt Guard
26	732-0357A	N	Extension Spring 1.12" Lg.	56	710-1001		Truss B-Tap Scr. 5/16 x .75"
27	717-0419A		Lower Hsg. Half†	57	736-0242		Bell-Wash. .345" I.D. x .88"
28	741-0415		Flange Bearing .566 Dia.†	58	†		Hub Cap
29	717-0422A		33 Tooth Helical Gear†	59	746-0712A		S.P. Cable 44" Lg.
30	741-0414		Flange Bearing .629 Dia.†	60	736-0222		External L-Wash. 1/4" I.D.
31	721-0213		Oil Seal .625 Dia.†	61	741-0180		Ball Bearing 1/2" I.D. (Optional)
32	738-0607A		Gear Sprocket Shaft†	62	736-0232		Wave Wash. .53" I.D. x .78"

† Part of Transmission Complete, Ref. No. 36.

Models 115R and 118R



This instruction manual covers various models, and all specifications shown do not necessarily apply to your model. Specifications subject to change without notice or obligation.

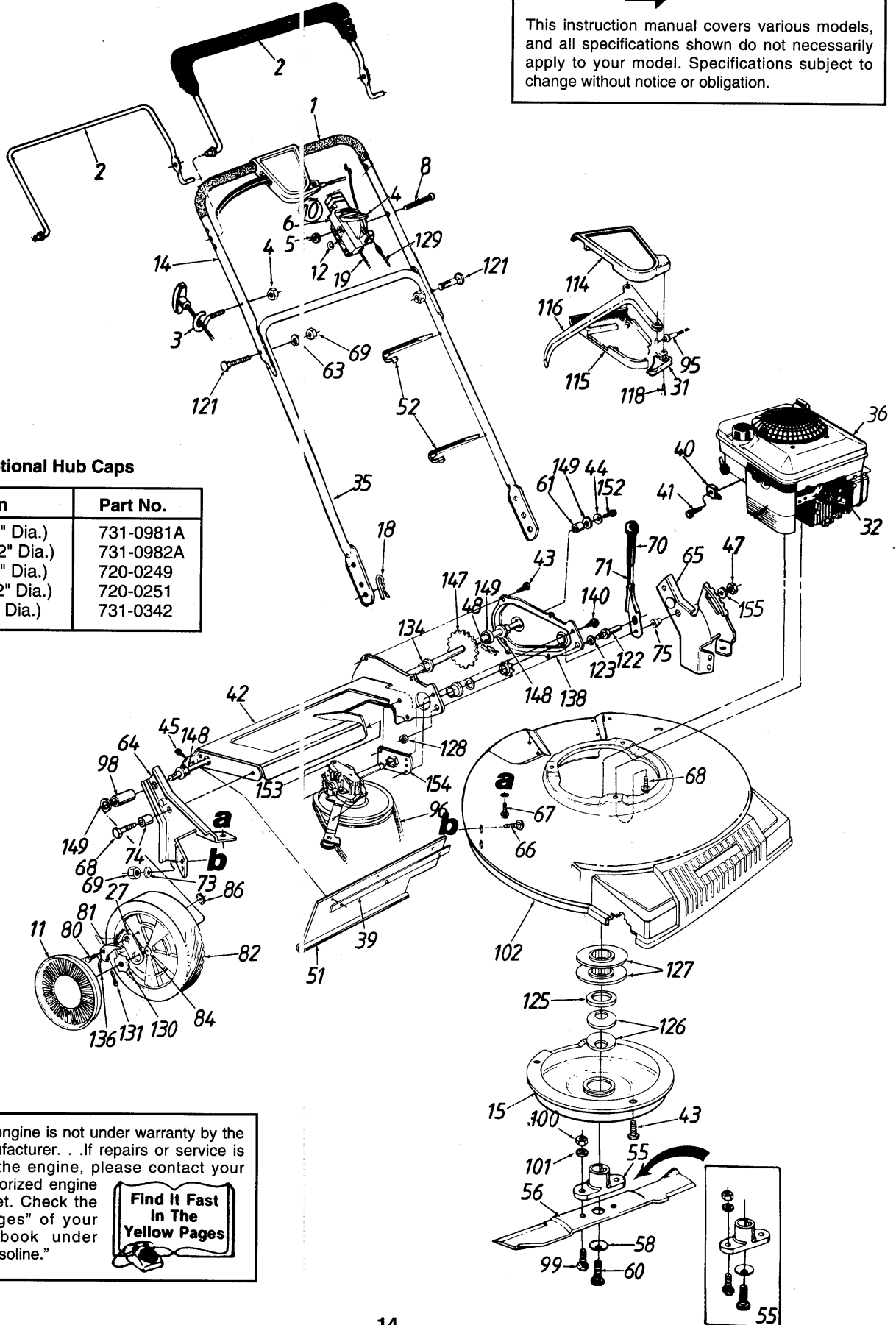

†Optional Hub Caps

Description	Part No.
Gray (5-1/2" Dia.)	731-0981A
Beige (5-1/2" Dia.)	731-0982A
Gray (3-1/2" Dia.)	720-0249
Black (1-1/2" Dia.)	720-0251
Red (1-3/8" Dia.)	731-0342

NOTE: The engine is not under warranty by the mower manufacturer. . .If repairs or service is needed on the engine, please contact your nearest authorized engine service outlet. Check the "Yellow Pages" of your telephone book under "Engines-Gasoline."



Models 115R and 118R

PARTS LIST FOR MODELS 115R AND 118R ROTARY MOWERS

REF. NO.	PART NO.	CODE	DESCRIPTION	REF. NO.	PART NO.	CODE	DESCRIPTION
1	720-0225		Grip (Optional)	68	710-0654A		Hex TT-Tap Scr. 3/8-16
2	647-0004	N	Control Handle w/Plastic	69	712-0267		Hex Nut 5/16-18 Thd.*
	747-0824	N	Control Handle	70	720-0223		Grip
3	710-1205		Rope Guide	71	732-0580		Height Adj. Lever
4	712-0324		Hex L-Nut 1/4-20 Thd.	73	736-0242		Bell-Wash. 5/16" I.D.
5	712-0291		Hex L-Nut 1/4-20 Thd.	74	750-0736		Spacer .383" I.D.
6	746-0875	N	Throttle Body	75	750-0624		Shld. Spacer .5" Dia.
8	710-0605	N	Oval C-Sunk Scr.	80	738-0137		Shld. Scr. .342" Dia. x .268
9	745-0876	N	Throttle Lever	81	748-0188B		Pawl
10	811-00185	N	Throttle Box Comp. (Incl. Ref. 5, 6, 8, 9, 12)	82	**		Wheel Ass'y. Comp.—Rear
				84	741-0486B		Sleeve Bearing 1/2" I.D. (Optional)
11	†		Hub Cap				
12	736-0501	N	Spr. Wash. .66" I.D.	86	712-0414		Weld Top L-Nut 1/4-20 Thd.
14	749-0539B	N	Upper Handle	95	746-0712A		S.P. Cable—44" Lg.
15	782-7522		Belt Cover	96	754-0343		"V"-Belt
18	714-0104		Internal Cotter Pin 5/16" Dia.	98	711-0313		Sleeve .526" I.D.
19	746-0843	N	Throttle Control Wire 55" Lg. (118R)	99	710-1055		Hex Bolt 3/8-24 x 1.0" Lg.
	746-0844	N	Throttle Control Wire 39" Lg. (115R)	100	712-0241		Hex Nut 3/8-24 Thd.
				101	736-0169		L-Wash. 3/8" I.D.
				102	782-0015	638	21" Deck Ass'y.
26	712-0287		Hex Nut 1/4-20 Thd.*	114	731-1057		Self-Propelled Control Cover
27	16855		Pawl Plate	115	731-1058		Self-Propelled Control Cover
31	731-1059		S.P. Control Cover	116	731-0620		Control Lever
32	735-0639		Spark Plug Insulator	118	710-0841		Fl-"C"-Sunk Hd. Tap Scr. #10 x .75" Lg.
35	749-0372B		Lower Handle				
36	—		Engine	121	710-0671		Curved Carr. Bolt 5/16-18 x 1.38" Lg.
39	14835		Retaining Strip				
40	751-0568	N	Cable Clamp (118R)	122	711-0805		Shld. Pin 1.43" Lg.
41	710-1237	N	Hex Self-Tap Scr. #10-32 x .62" (118R)	123	736-0169		L-Wash. 3/8" I.D.
				125	748-0332		Crankshaft Spacer
42	682-7507		Chain—Axle Ass'y.	126	736-0450		Bell-Wash. 1.01" I.D.
43	710-0352		Hex B-Tap Scr. 1/4" x .38"	127	756-0502		Pulley Half—Serrated
44	736-0270		Bell-Wash. 1/4" I.D.	128	712-0711		Hex Jam Nut 3/8-24 Thd.*
45	710-0776A		Hex AB-Tap Scr. 1/4 x .62"	129	746-0550		Control Cable—39" (118R)
47	712-0296		Hex Patch L-Nut 3/8-24 Thd.		746-0727		Control Cable 51" Lg. (115R)
48	713-0361		#48 Chain .500" Pitch x 38 Links	130	748-0318		Ratchet Wheel 1.62" O.D.
				131	714-0115		Cotter Pin 1/8" Dia. x 1"
51	731-0672A		Rear Flap 3.75" x 17.30" Lg.	134	741-0522		Hex Flange Bearing
52	726-0240		Cable Tie	136	10622B		Spring—Nylon
55	753-0519		Blade Adapter Kit	138	682-7506		Chain Cover Ass'y.
56	742-0563		21" Mulching Blade	140	710-0599		Hex S-Tap Scr. 1/4-20 x .50"
58	736-0453		Bell-Wash. .47" I.D. x 1.14" O.D.	147	738-0864		Rear Shaft Ass'y. 21.44" Lg.
				148	741-0324		Hex Flange Brg. .506" I.D.
60	710-0561		Hex Bolt 7/16-20 x 2.5"	149	736-0160		Fl-Wash. .531" I.D. x .930"
61	748-0190		Spacer .513" I.D.	152	710-0751		Hex Bolt 1/4-20 x .62" Lg. (Grade 5)
63	736-0119		L-Wash. 5/16" I.D.*				
64	682-3006	N	R.H. Handle Wheel Brkt. Ass'y.	153	717-0417B		Transmission Comp. (See Breakdown)
65	682-3007	N	L.H. Handle Wheel Brkt. Ass'y.				
66	710-0260		Carriage Bolt 5/16-18 x .62"	154	16500A		Hex Bearing Cup
67	710-0603		Hex B-Tap Scr. 5/16-18	155	736-0300		Fl-Wash. .385" I.D. x .87" O.D.

*For faster service obtain standard nuts, bolts and washers locally. If these items cannot be obtained locally, order by part number and size as shown on parts list.

CODE: N notates a new part (not previously existing). A three digit number is the color code. (use if color or finish is important when ordering parts). [i.e., (part no.)-638 for Red Mist Finish].

**REAR WHEEL CHART

Size	Tread Type	Part No.
8" x 1.75"	Bar Tread	634-0020
8" x 2"	"S" Wave	734-1510B (Silver)
8" x 2"	"S" Wave	734-1514B (Beige)

TROUBLE SHOOTING GUIDE

Trouble	Possible Cause(s)	Corrective Action
Engine fails to start	<ol style="list-style-type: none"> 1. Blade control handle disengaged. 2. Spark plug wire disconnected. 3. Throttle control lever not in START position. 4. Fuel tank empty, or stale fuel. 5. Blocked fuel line. 6. Faulty spark plug. 7. Engine flooded 	<ol style="list-style-type: none"> 1. Engage blade control handle. 2. Connect wire to spark plug. 3. Move throttle lever to START position. 4. Fill tank with clean, fresh gasoline. 5. Clean fuel line. 6. Clean, adjust gap or replace. 7. Remove spark plug, dry the plug, and crank engine with plug removed and throttle in off position. Replace spark plug, connect wire and resume starting procedures.
Engine runs erratic	<ol style="list-style-type: none"> 1. Unit running in START position. 2. Spark plug wire loose. 3. Blocked fuel line or stale fuel. 4. Vent in gas cap plugged. 5. Water or dirt in fuel system. 6. Dirty air cleaner. 7. Carburetor out of adjustment. 	<ol style="list-style-type: none"> 1. Move throttle lever to FAST position. 2. Connect and tighten spark plug wire. 3. Clean fuel line; fill tank with clean, fresh gasoline. 4. Clear vent. 5. Drain fuel tank. Refill with fresh fuel. 6. Clean air cleaner. † 7. Adjust carburetor. †
Engine overheats	<ol style="list-style-type: none"> 1. Engine oil level low. 2. Air flow restricted. 3. Carburetor not adjusted properly. 	<ol style="list-style-type: none"> 1. Fill crankcase with proper oil. 2. Remove blower housing and clean. † 3. Adjust carburetor. †
Occasional skip (hesitates) at high speed	<ol style="list-style-type: none"> 1. Spark plug gap too close. 2. Carburetor idle mixture adjustment improperly set. 	<ol style="list-style-type: none"> 1. Adjust gap to .030". 2. Adjust carburetor. †
Idles poorly	<ol style="list-style-type: none"> 1. Spark plug fouled, faulty or gap too wide. 2. Carburetor improperly adjusted. 3. Dirty air cleaner. 	<ol style="list-style-type: none"> 1. Reset gap to .030" or replace spark plug. 2. Adjust carburetor. † 3. Clean air cleaner. †
Excessive vibration	<ol style="list-style-type: none"> 1. Cutting blade loose or unbalanced. 2. Bent cutting blade. 	<ol style="list-style-type: none"> 1. Tighten blade and adapter. Balance blade. 2. Replace blade.
Mower will not discharge grass	<ol style="list-style-type: none"> 1. Engine speed too low. 2. Wet grass. 3. Excessively high grass. 	<ol style="list-style-type: none"> 1. Set throttle between 3/4 and full throttle. 2. Do not mow when grass is wet; wait until later to cut. 3. Mow once at a high cutting height, then mow again at desired height or make a narrower cutting swath (1/2 width).
Uneven cut	<ol style="list-style-type: none"> 1. Wheels not positioned correctly. 2. Dull blade. 	<ol style="list-style-type: none"> 1. Place all four wheels in same height position. 2. Sharpen or replace blade.

† Refer to separate engine manual packed with your unit.

Note: For repairs beyond the minor adjustments listed above, contact your local authorized service dealer.

**FOR REPLACEMENT PARTS, CONTACT:
SERVICE DEPARTMENT • P. O. BOX 360900 • CLEVELAND, OHIO 44136**