

# OWNER'S GUIDE

**Model No. 121-450-R**

## SELF-PROPELLED ROTARY MOWER

### WARRANTY

For one year from date of purchase, MTD Products, Inc., will replace for the original purchaser, free of charge, F.O.B. factory or authorized service firm, any part or parts found to be defective in material or workmanship. All transportation charges on parts submitted for replacement under this warranty must be paid by the purchaser. This warranty does not include replacement of parts which become inoperative through misuse, excessive use, accident, neglect, improper maintenance or alterations by unauthorized persons. This warranty does not include the engine, motor, battery, battery charger or any component parts thereof. For service on these units refer to the applicable manufacturer's warranty.

The above warranty will apply only to the original owner and will be effective only if the warranty card has been properly processed. It will not apply where the unit has been used commercially.

Warranty service is available through your local authorized service dealer or distributor. UNDER NO CIRCUMSTANCES WILL THE RETURN OF A COMPLETE UNIT BE ACCEPTED BY THE FACTORY UNLESS PRIOR WRITTEN PERMISSION HAS BEEN EXTENDED.

### SAFETY RULES

Your rotary mower is a precision piece of power equipment, not a plaything. Therefore exercise extreme caution at all times.

1. Remove all sticks, stones, wire and other hazardous items from lawn before mowing. Such items are dangerous to both the mower and individuals in the vicinity of the mower.
2. Always disconnect spark plug cable during repairs or refueling operations.
3. Always start engine from side opposite discharge chute.
4. NEVER place hands or feet under mower or near discharge chute while engine is running.
5. Do not tilt mower at extreme angle while engine is running. Cut grass on hills and banks sideways, not up and down.
6. Always stop engine when not cutting grass.
7. Do not fill gas tank while engine is running. Do not spill gasoline on hot engine.
8. Keep children and pets away from area at all times during mowing operation. Never allow mower to discharge grass toward any person.
9. Do not attempt to start engine while mower is resting in high grass.
10. Check all nuts and bolts, particularly the blade bolts, for tightness. This is especially important during the initial operation period. Make this same check periodically thereafter.
11. While operating the mower, if any foreign object is struck, stop the mower and inspect for damage. Do not restart or operate the mower until all damage has been repaired.

**WARNING:** Should excessive vibration develop, check your blade and crankshaft immediately. Do not operate mower with an unbalanced blade, a damaged blade or a damaged crankshaft.

MANUFACTURED BY

MTD PRODUCTS INC • 5389 WEST 130th ST. • P. O. BOX 2741 • CLEVELAND, OHIO 44111

FORM NO. 770-3319A

# ASSEMBLY INSTRUCTIONS

Note: Follow instructions starting with number 1 and continue through number 11.

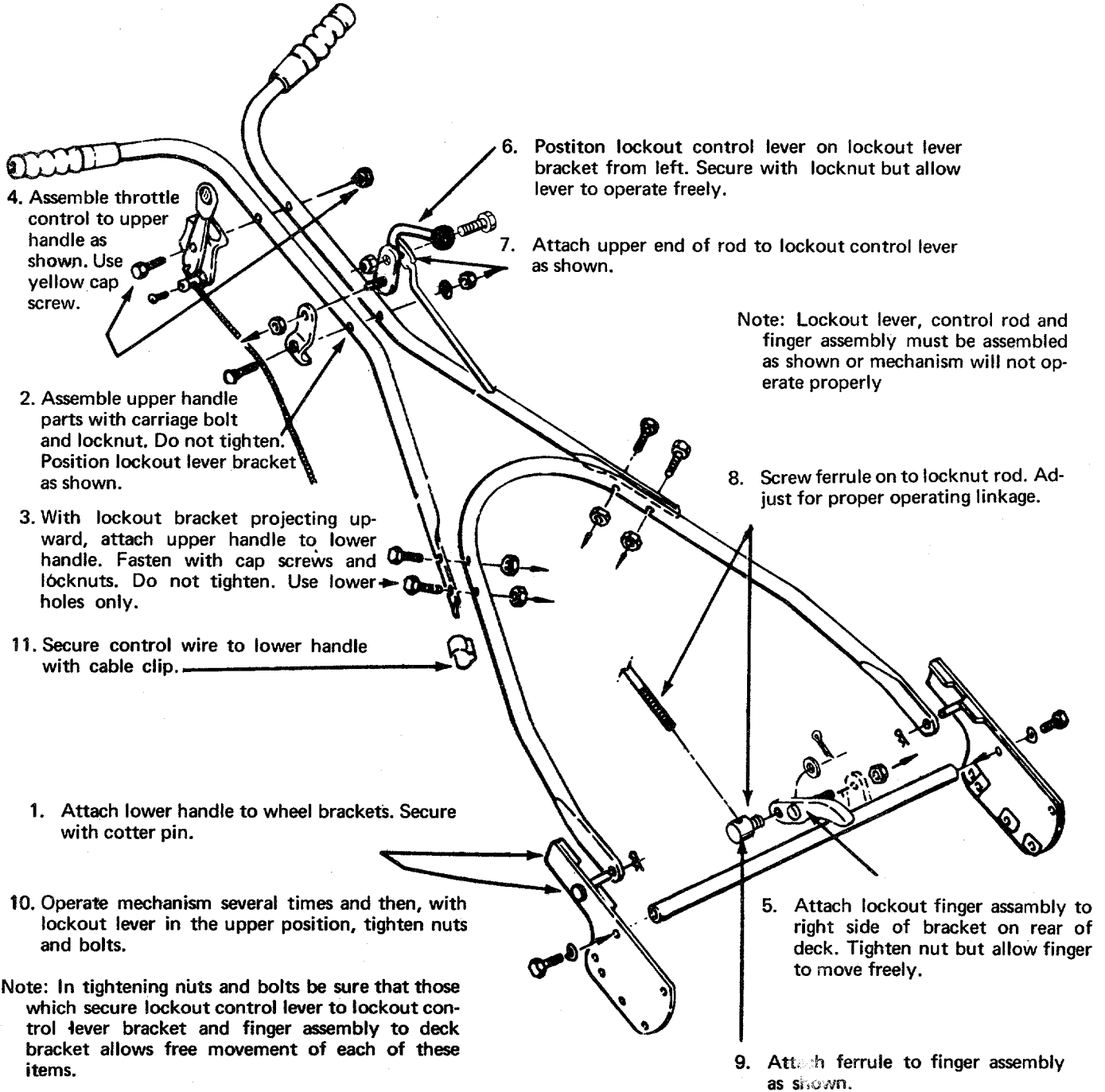

# 121-450-R.

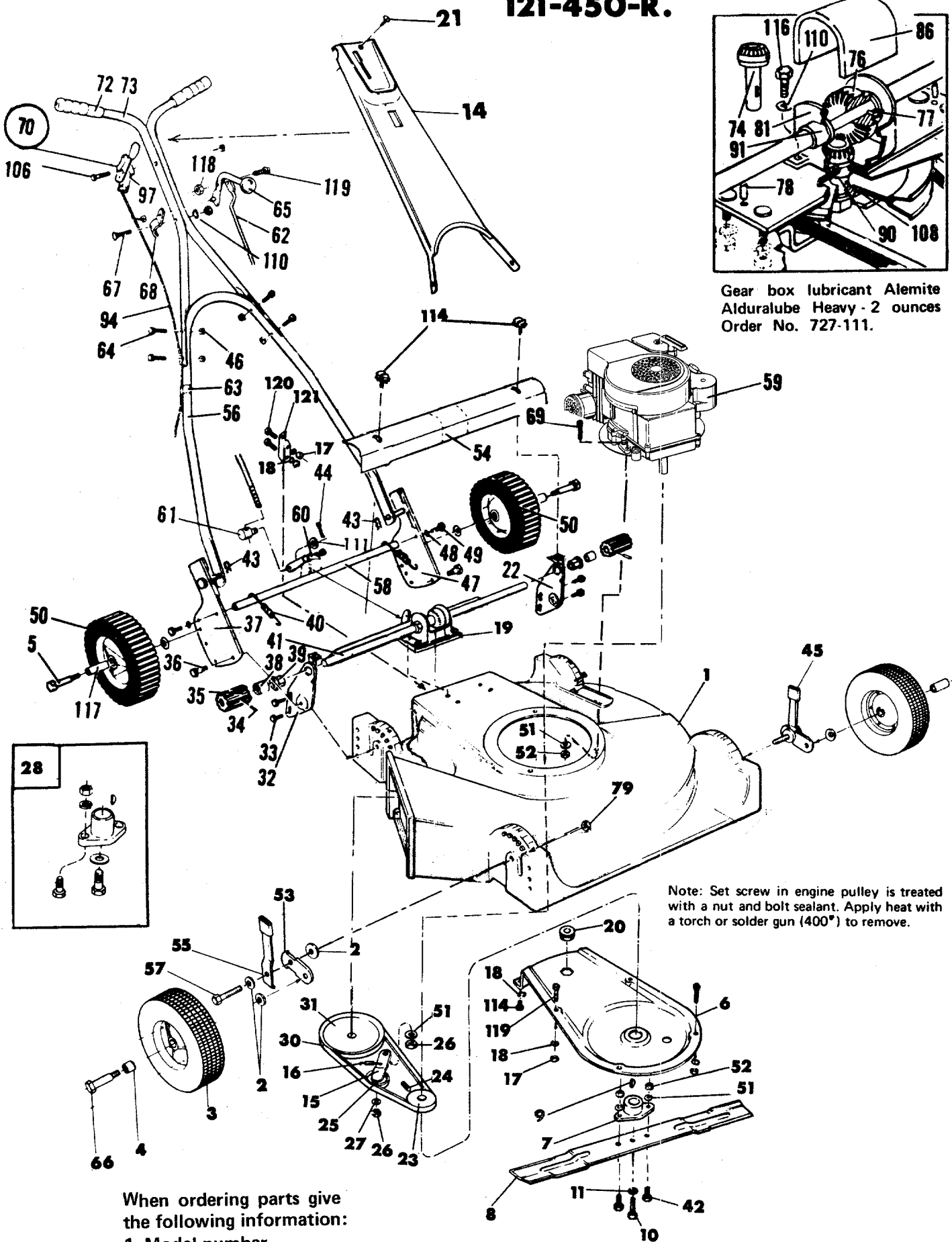

Gear box lubricant Alemite  
Alduralube Heavy - 2 ounces  
Order No. 727-111.

Note: Set screw in engine pulley is treated with a nut and bolt sealant. Apply heat with a torch or solder gun (400°) to remove.

When ordering parts give the following information:

1. Model number
2. Part number
3. Part name
4. Color of part

**PARTS LIST FOR MOWER MODEL NO.121-450-R.**

Ref. No.	Part No.	DESCRIPTION	Ref. No.	Part No.	DESCRIPTION
1	437-8791	Deck Assembly	50	503-9392	Wheel Assembly -- Rear
2	736-105	Belleville Washer	51	736-119	Lockwasher 5/16 Screw **
3	505-9392	Wheel Assembly -- Front	52	712-123	Hex Nut 5/16--24 Thd. *
4	305-7006	Bearing -- Fortiflex -- Front Wheel	53	310-7492	Wheel Pivot Bar
5	738-212	Axle Bolt Rear (2 req'd.)	54	437-10543	Drive Cover
6	312-8220	Air Flo Shield	55	310-8243	Spring Lever Assembly
7	748-189	Blade Adapter **	56	310-8390	Lower Handle
8	312-8125	Blade 21"	57	710-191	Hex Hd. Cap Scw. 3/8--24 x 1-1/4" Lg.
9	714-365	Key -- Hi Pro No. 505"	58	310-7574	Tie Bar
10	710-459	Hex Hd. Cap Scw. 3/8--24 x 1-1/2" Lg. (Heat Treated) **	59	-----	Engine
11	736-217	Lock Washer 3/8 Screw **	60	310-10036	Lockout Finger
12	710-473	Truss Hd. Mach. Scw. 10--24 x 1/2"	61	711-392	Ferrule
13	712-425	Square Nut #10--24 Thd.	62	711-395	Lockout Rod
14	437-7859	Handle Cover	63	746-128	Cable Clip
15	310-8221	Idler Bracket Assembly	64	710-106	Hex Hd. Cap Scw. 1/4--20 x 1-1/4" Lg. *
16	732-250	Idler Spring	65	310-8098	Lockout Lever Assembly
17	712-287	Hex Nut 1/4--20 Thd. *	66	738-101	Axle Bolt -- (2 req'd.) -- Front
18	736-329	Lockwasher 1/4 Screw *	67	710-256	Carriage Bolt 1/4--20 x 1-1/2" Lg. *
19	312-8223	Spacer Plate	68	310-7660	Lockout Lever Bracket
20	748-226	Bearing -- Pinion Shaft	69	710-158	Hex Hd. Cap Scw. 5/16--24 x 1-1/4" Lg. *
21	710-138	Truss Hd. Mach. Scw. #10--24 Thd. *	70	310-8518	Throttle Control -- Complete
22	310-10545	Tie Bracket Assembly -- L.H.	72	305-7071	Grip (2 req'd.) -- Black
23	756-230	Engine Pulley	73	310-9364	Handle Upper (2 req'd.)
24	710-257	Set Screw -- Special	74	901-7957	Pinion Assembly
25	756-370	Idler Pulley	76	748-135	Bevel Gear
26	712-372	Hex Lock Nut 5/16--18 Thd. *	77	715-246	Roll Pin 3/16 Dia. x 1-1/4" Lg. *
27	736-300	Flat Washer 3&8 I.D. x 7/8 O.D.	78	715-248	Roll Pin 3/16 Dia. x 3/4" Lg. *
28	901-10769	Blade Adapter Kit -- Less Blade	79	712-214	Hex Elastic Locknut 3/8--24 Thd. *
29	723-124	Retaining Clip (Not Shown)	81	717-108	Gear Box
30	754-935	"V" Belt 1/2" x 31" Lg.	86	310-7716	Gear Boc Cover
31	310-9927	Pulley -- Drive	90	748-108	Bearing Flange -- Pinion Shaft
32	310-10546	Tie Bracket Assembly -- R. H.	91	748-110	Bearing Flange -- Drive Shaft
33	710-209	Sems Hex Hd. Cap Scw. 3/8--16 x 5/8" Lg. *	94	732-143	Conduit and Wire †
34	715-247	Roll Pin 3/16 Dia. x 1" Lg. *	97	310-10006	Throttle Control Bracket †
35	305-7120	Pinion -- Drive	100	305-7470	Knob †
36	711-110	Pivot Screw	101	901-7627	Ferrule Assembly ( Complete) †
37	310-8342	Handle Bracket -- R. H.	106	710-606	Hex Hd. Cap Scw. 1/4--20 x 1-1/2" Lg. *
38	310-2265	Sleeve	108	714-229	Key -- Woodruff #2
39	748-227	Bearing -- Drive Shaft	110	736-498	Lockwasher 1/4" Screw *
40	732-117	Tension Spring	111	736-463	Flat Washer 9/32 I.D. x 5/8 O.D.
41	310-7224	Drive Shaft	112	712-344	Speednut
42	710-117	Hex Hd. Cap Scw. 5/16--24 x 1" Lg. (Heat Treated) **	113	712-429	Elastic Stop Nut
43	714-104	Cotter -- Hairpin *	114	710-239	Sems Truss Hd. Mach. Scw. #10--24x3/8" Lg.
44	714-507	Cotter Pin	116	710-289	Hex Hd. Cap Scw. 1/4--20 x 1/2" Lg. *
45	305-7520	Knob	117	748-125	Bearing -- Rear Wheel
46	712-107	Hex Center Lock Nut 1/4--20 Thd. *	118	712-324	Hex Elastic Stop Nut 1/4--20 Thd. *
47	310-8343	Handle Bracket -- L. H.	119	710-252	Hex Hd. Cap Scw. 1/4--20 x 3/4" Lg. *
48	736-114	Lockwasher 1/2 Screw *	120	710-258	Hex Hd. Cap Scw. 1/4--20 x 5/8" Lg. *
49	710-121	Hex Hd. Cap Scw. 1/2--20 x 3/4" Lg. *	121	393-8119	Stop Bracket
			122	305-9871	Hub Cap (Not Shown)

\* For faster service obtain standard nuts, bolts, and washers locally. If these items cannot be obtained locally, order by part number and size as shown on parts list.

† Part of Control -- Throttle (Complete) 310-8518.

\*\* Part of Blade Adapter Kit Complete (Less Blade) 901-10769.

Drive Assembly -- Complete 901-8160.

# HOW TO GET THE MOST FROM YOUR NEW SELF-PROPELLED MOWER

## GENERAL

The purpose of this sheet is to further acquaint the owner of this Self-Propelled Mower with information which will enable him to get from his unit the most efficient and maximum service life.

Because this type of mower is propelled by a mechanism which consists of a bevel and pinion gear, lubrication is of prime importance. The bevel and pinion gears are made of sintered iron and they are housed in a small gear box mounted on the center rear of the mower deck. This box is lubricated at the factory with two ounces of Alemite Alduralube Heavy grease. The grease in this box should be maintained at a level which completely covers the pinion gear (the smaller gear on the bottom of the gear box). The gear box should never be permitted to run dry. Periodic inspection is a necessity. Should additional grease be needed, a high heat, fibrous wheel bearing lubricant should be used. Cup grease or gun grease will last no longer than a single mowing. If grease is needed often, the grease being used is of the wrong type. It is suggested that Alemite Alduralube Heavy, Alemite Temprite No. 2 or an equivalent type and quality grease be used.

This mower should be broken in following the procedure described in the break-in instructions. The added effort here will double the service life of the unit. Particular attention should be paid to the notes on alignment.

When operating this mower, unnecessary or excessive engaging of the drive pinions with the wheels should be avoided. This is achieved by minimizing the raising and lowering of the handle during the mowing operation. Failure to observe this operating rule can reduce the service life of the rear tires and drive pinions substantially. When engaging the self-propelled mechanism, a slight forward push on the mower as the drive pinions and the gear tread tires mesh will add to smoother and quieter operation. In addition to a smoother operation, it will add substantially to the service life of both the tires and the drive pinions.

## HANDLE ASSEMBLY PRECAUTIONS

Although the handle is of a simple design, difficulty has been encountered in its assembly. Certain precautions concerning its assembly must be heeded. The handle must be assembled as shown in the diagram. Trouble arises when certain parts are put together improperly.

- Mount the lockout finger on the right side of the bracket. See illustration.
- Lockout control lever must be mounted as shown in the illustration.
- The lockout control lever bracket must be mounted with the projection upward as shown in the illustration.
- If lower handle is too narrow to lock into handle bracket, spread as needed.

## BREAK-IN INSTRUCTIONS

- Before starting the engine, lubricate all the bronze bearings on the drive shaft. The same oil which is used for the engine may be used for this.
- Check lubricant in the gear box. This must be maintained half full at all times and should be checked prior to each mowing. The gear box is packed at the factory with Alemite Alduralube Heavy or Alemite Temprite No. 2. It is suggested that this or an equivalent type and quality fibrous high heat wheel bearing grease be used in maintaining this mechanism.
- Check the lockout control for proper operation. See HANDLE ASSEMBLY PRECAUTIONS.
- Check drive assembly alignment. When the lockout control lever is moved to the Self-Propelled position (as shown in diagram), the black nylon drive pinions should mesh simultaneously with the gear tread tires. The lockout control lever should move from Self-Propelled position to Free-Wheeling position easily. If either or both of these conditions do not exist, the alignment is incorrect. It may be remedied as follows:
  - Loosen the four Sems hex head cap screws which hold the tie bracket assemblies to the deck.
  - Loosen the carriage bolt which secures the lockout control lever bracket to the handle.
  - Move the lockout control lever from Self-Propelled to Free-Wheeling position several times.
  - Place the lockout control lever back into Self-Propelled Position.
  - Turn both rear wheels until the drive pinions mesh with gear tread tires.
  - Tighten all Sems hex cap screws.

- Move lockout control lever to Free-Wheeling position and tighten the carriage bolt which secures the lockout control lever bracket to the handle.
- With the lockout control lever in Free-Wheeling position, start the engine and allow it to run in a stationary position for about fifteen minutes at a slow speed. This will allow the moving parts to break in gradually.
  - If, after a few minutes of operation, the bearings and horizontal drive shaft become excessively hot, recheck the drive assembly alignment.
  - Proper lubrication must be maintained at all times.

## TROUBLE SHOOTING

If the mower fails to propel itself, the trouble may be located in the following manner. Ground the spark plug wire. Slowly crank the engine with the starter. If the starter is of the impulse type, set the starter control on "START" or "RUN" position. When the crankshaft of the engine turns, note the following:

- The drive shaft and the drive pinions rotate but the drive pinions do not drive the wheels. . . check the drive assembly alignment.
- The drive shaft rotates but the drive pinions do not. . . check the roll pins in the drive pinions or the drive pinions.
- The drive shaft does not rotate. . . remove the upper drive frame cover and the gear box cover.
- The bevel gear and pinion gear operates but the drive shaft does not. . . check the roll pin in the bevel gear.
- The pinion gear rotates but the bevel gear does not. . . check for worn bevel and/or pinion gear.
- Neither the bevel or pinion gear rotates. . . check for obstruction between bevel and pinion gears. If nothing is found, remove the blade assembly and air flo shield.
- The driven (large) pulley rotates. . . check for sheared or missing key in the driven pulley.
- The driven pulley does not rotate due to broken or defective "V" belt. . . check pulley alignment (drive pulley, driven pulley and idler pulley must be on an even plane with each other) and replace belt.
- The driven pulley does not operate due to improper idler pulley operation (the idler pulley must be under spring tension and it must revolve freely). . . repair or replace idler pulley.
- The drive pulley does not rotate. . . check for loose or missing set screw. The set screw should be treated with a nut, bolt and screw sealant (Lock it, Lock tite, etc.). The set screw should tighten into a "spot" on the engine crankshaft.

## REPLACING BEVEL AND PINION GEARS

- Remove spark plug wire. To prevent spillage, drain gasoline and oil from the engine.
- Remove the entire blade assembly. Remove the air flo shield.
- Remove the cover top drive frame assembly. Remove gear box cover.
- Remove roll pins from drive pinions and bevel gear.
- Carefully remove the belt and large pulley. CAUTION: Do not damage pulley.
- Remove pinion shaft assembly from gear box.
- Replace new pinion shaft assembly in gear box.
- Slide pulley onto new pinion shaft with the large hub towards the bottom of the mower (see illustration). THE PULLEY MUST SLIDE ONTO THE SHAFT EASILY. If it does not do so, check the Woodruff key. It must be assembled into the key seat straight and it must be free from burrs. Correct the Woodruff key so that the pulley goes on without any undue pressure.
- Replace "V" belt and install air flo shield.
- Loosen the four Sems hex head cap screws.
- Replace the drive shaft. Be sure all parts are positioned as shown in the illustration.
- Secure bevel gear and drive pinions with roll pins. Use the proper length pins for each (long pin for bevel gear . . . short pins for drive pinions).
- Place lockout control lever in Self-Propelled position. Move rear wheels until the drive pinions and gear tread tires mesh completely. Tighten all four Sems hex head cap screws.
- Replace blade assembly.
- Service gear box with the proper grease and lubricate the bronze bearings.
- Service the engine with gasoline and oil and replace the spark plug wire.

## OPERATION

1. Service engine with gas and oil. See Engine Manual packed with lawn mower for complete instructions for care and maintenance of engine. **READ DIRECTIONS CAREFULLY.**
2. Lubricate bronze bearings on drive shaft. Check gear box for proper level of lubricant. It is important that this is checked at the beginning of each mowing and that the gear box is maintained half full of the proper lubricant at all times.
3. Check drive assembly for correct alignment (see break-in instructions).
4. When ready to start engine, place throttle control lever into free wheeling position. This is done by pressing down the handle and snapping the lockout control lever back. Start engine in accordance with instructions in Engine Manual. After engine starts, move throttle control lever on handle to the desired engine speed.
5. Lockout control lever may now be moved forward for self-propelled operation. When the lockout control lever is in the forward position, the drive pinions engage with the gear tread tires and forward drive results.
6. Temporary free wheeling is achieved by depressing the handle. Self-propelled drive is resumed when handle is released. . . Engine is stopped by placing control lever on handle into "Stop" position.

## LUBRICATION

**IMPORTANT:** Always stop engine and disconnect spark plug wire before cleaning, lubricating or doing any kind of work on lawn mower.

**WHEELS** – The bearings on the front wheels of your lawn mower are made of Lifetime Fortiflex. No lubrication is required. Lubricate rear wheel bearings as needed.

**THROTTLE** – Periodically lubricate throttle control lever and throttle wire assembly with a few drops of light oil (S.A.E. No. 10 or 20) for ease of operation.

**BRONZE BEARINGS** – Periodically lubricate all bronze bearings with a few drops of light oil (S.A.E. No. 10 or 20) to minimize friction.

**GEAR BOX** – The bevel and pinion gears *must* be lubricated at all times. The gear box containing these should be checked before each mowing. Keep gear box half full of proper lubricant. Alemite Alduralube Heavy is used at the factory. This or an equivalent wheel bearing grease is recommended.

**ENGINE** – Follow Engine Manual for lubrication instructions.

## ADJUSTMENTS

**CAUTION:** Do not at any time make any adjustment to lawn mower without first stopping engine and disconnecting spark plug wire.

**BELT ADJUSTMENT** – Proper tension on the ½-inch "V" belt (30) is maintained by the spring-loaded idler (25). Should this belt ever require replacement, the following procedure should be followed to remove the belt.

1. Remove blade from crank-shaft (see Diagram).
2. Detach air-flow shield (6) from deck (1) by removing mounting screws (14 and 21).
3. Remove four nuts and lockwashers that hold bottom drive frame assembly (19) in position, exposing rear pulley (31).
4. Remove belt and install new replacement. The 1/2 inch "V" belt is of standard size and available at most mower repair shops, hardware stores and automotive service stations.
5. Re-assemble all parts in reverse order from above.

**CUTTING HEIGHT ADJUSTMENT** – Adjustment may be made by removing and moving wheel axle bolts to desired position. Cutting height will be raised as axle bolts are moved to a lower hole and lowered as axle bolts are moved to a higher hole in the deck. All axle bolts must be mounted in a relative position to the deck.

**THROTTLE** – If adjustment becomes necessary, the throttle control wire assembly can be reset as follows:

1. Loosen, but do not remove, screw securing throttle control wire assembly at engine.
2. Move throttle control lever on handle to "Fast" position.
3. Move lever, to which control wire is fastened at engine, to full choke position and retighten screw to secure throttle control wire assembly.

## MAINTENANCE

**CUTTING BLADE** – The blade may easily be removed for grinding or replacement as follows:

1. Remove bolt and lock washer holding blade and hub assembly to engine crankshaft.
2. Remove blade and hub assembly from engine crankshaft.
3. Remove two bolts, lock washers and nuts holding blade to blade hub.

When sharpening blade, follow the original angle of grind as a guide. It is extremely important that each cutting edge receives an equal amount of grinding to prevent an unbalanced blade. An unbalanced blade will cause excessive vibration when rotating at high speeds and may cause damage to the mower.

Upon reassembly, make certain all parts are assembled properly and tightened securely.

**DECK** – The underside of mower deck should be cleaned after each period of use as grass clippings, leaves, dirt and other matter will accumulate. This accumulation of grass clippings, etc., is undesirable as it will invite corrosion and may cause an uneven discharge of grass clippings at the next cutting.

The deck may be cleaned by tilting the mower forward or on its left side and scraping clean with a suitable tool or by washing with a stream of water from a garden hose. **CAUTION:** Do not direct the stream of water at a hot engine as damage to the engine may result.

**STORAGE** – The following steps should be taken to prepare lawn mower for storage.

1. Clean and lubricate mower thoroughly as described in the preceding instructions.
2. Refer to engine manual for correct engine storage instructions.
3. Coat mower's cutting blade with chassis grease to prevent rusting.
4. Place blocks under deck to raise tires clear of floor.
5. Store mower in dry, clean area.

### USING YOUR ROTARY MOWER

For the best results do not cut wet grass because it tends to stick to the underside of the mower thus preventing proper discharge of grass clippings. If wet grass must be cut, reduce engine speed and walking speed to help distribute the clippings more effectively.

New grass should be treated as wet grass, otherwise a normal walking speed is about the right pace for

efficient mowing. The best mowing pattern is one that allows the clippings to discharge towards the uncut part of the lawn. This permits recutting of the clippings to further pulverize them. When cutting high weeds, discharge towards cut portion then recut at right angles to first direction.

Lawn should be cut in the fall as long as there is growth.

### PRECAUTIONS

1. Before using your new mower for the first time be sure to follow break in instructions.
2. Maintain proper lubricant level in gear box.
3. Avoid unnecessary or excessive engaging of the drive pinions. For reduced wear and quieter operation, move mower slightly forward as lockout control lever is moved forward for self propelled operations.
4. Check blade bolt for proper tightness before operating mower.

**NOTE!** This instruction manual covers various models, and all accessories shown do not necessarily apply to your model mower.

If repairs or service is needed on the engine, please contact your nearest authorized engine service outlet. Check the "Yellow Pages" of your telephone book under "Engines – Gasoline."



## REPLACING BROKEN HORIZONTAL DRIVE SHAFT ASSEMBLY

### INSTRUCTIONS

1. Remove spark plug wire.
2. Place lockout control lever in free wheeling position to disengage drive pinions from rear wheels.
3. Set wheels in the high cutting positions.
4. Remove cover top drive frame assembly and gear box cover.
5. Remove broken horizontal drive shaft. Use knockout pin provided in kit to remove roll pin from bevel gear.
6. Loosen the Sems hex head cap screws which attach the tie brackets to each side of the deck.
7. Tap both tie brackets lightly from the bottom to assure easy assembly of the drive shaft.
8. The replacement drive shaft already has one drive pinion assembled. Replace the drive shaft in the assembly by entering it from the right hand side. Be sure that all parts are positioned as shown.
9. Secure bevel gear and drive pinions with roll pins. Use the proper length pins for each (long pin for bevel gear, short pin for drive pinion).
10. Place lockout control lever in self-propelled position. Move rear wheels until the drive pinions and the gear tread tires mesh completely. Tighten all Sems hex head cap screws securely.
11. Service gear box with grease provided. Lubricate the bronze bearings with light oil.
12. Replace cover top drive frame assembly and spark plug wire.

