

\$1.00

# OWNER'S GUIDE

ASSEMBLY • OPERATION • MAINTENANCE • PARTS

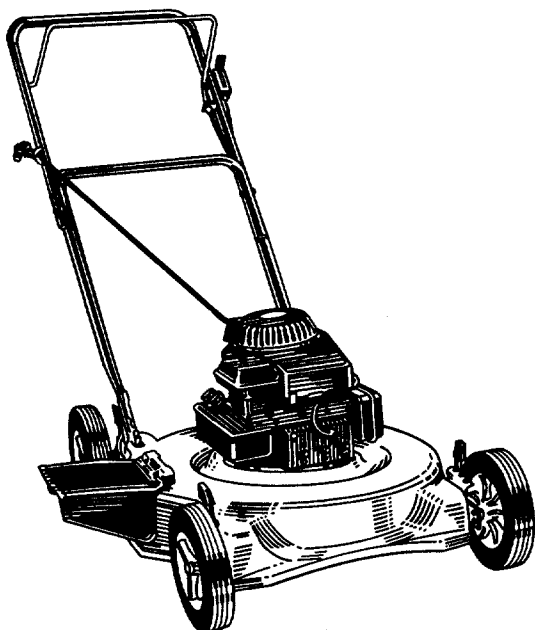

(Models 072R and 082R Shown)

## 20" and 22" ROTARY MOWERS

111-202R054

111-228R

### Model Series

111-070R000 thru 111-078R000

111-080R000 thru 111-089R000

111-200R000 thru 111-206R000

111-220R000 thru 111-226R000

SUPPLEMENT SHEET PM180

190-086-000

**Important: Read Safety Rules and Instructions Carefully**



**WARNING:** This unit is equipped with an internal combustion engine and should not be used on or near any unimproved forest-covered, brush-covered or grass-covered land unless the engine's exhaust system is equipped with a spark arrester meeting applicable local or state laws (if any). If a spark arrester is used, it should be maintained in effective working order by the operator.

In the State of California the above is required by law (Section 4442 of the California Public Resources Code). Other states may have similar laws. Federal laws apply on federal lands. A spark arrester for the muffler is available through your nearest engine authorized service dealer or contact the service department, P.O. Box 360900, Cleveland, Ohio 44136.

# IMPORTANT

## RULES FOR SAFE OPERATION



THIS SYMBOL POINTS OUT IMPORTANT SAFETY INSTRUCTIONS WHICH, IF NOT FOLLOWED, COULD ENDANGER THE PERSONAL SAFETY AND/OR PROPERTY OF YOURSELF AND OTHERS. READ AND FOLLOW ALL INSTRUCTIONS IN THIS MANUAL BEFORE ATTEMPTING TO OPERATE YOUR LAWN MOWER. FAILURE TO COMPLY WITH THESE INSTRUCTIONS MAY RESULT IN PERSONAL INJURY. WHEN YOU SEE THIS SYMBOL—



**HEED ITS WARNING.**



### DANGER:

Your lawn mower was built to be operated according to the rules for safe operation in this manual. As with any type of power equipment, carelessness or error on the part of the operator can result in serious injury. If you violate any of these rules, you may cause serious injury to yourself or others.



### TRAINING

1. Read this owner's guide carefully in its entirety before attempting to assemble or operate this machine. Be completely familiar with the controls and the proper use of this machine before operating it. Keep this manual in a safe place for future and regular reference and for ordering replacement parts.
2. Your rotary mower is a precision piece of power equipment, not a plaything. Therefore, exercise extreme caution at all times. Your unit has been designed to perform one job: to mow grass. Do not use it for any other purpose.
3. Never allow children under 14 years old to operate a power mower. Children 14 years old and over should only operate mower under close parental supervision. Only persons well acquainted with these rules of safe operation should be allowed to use your mower.
4. Keep the area of operation clear of all persons, particularly small children and pets. Stop engine when they are in the vicinity of your mower to help prevent blade contact or thrown object injury. Although the area of operation should be completely cleared of foreign objects, an object may have been overlooked and could be accidentally thrown by the mower in any direction and cause serious personal injury to the operator or any others allowed in the area.



### PREPARATION

1. Thoroughly inspect the area where the equipment is to be used. Remove all stones, sticks, wire, bones and other foreign objects which could be picked up and thrown by the mower in any direction and cause serious personal injury to the operator or any others allowed in the area. Plan your mowing pattern to avoid discharge of material toward roads, sidewalks, bystanders and the like.
2. Always wear safety glasses or eye shields during operation or while performing an adjustment or repair, to protect eyes from foreign objects that may be thrown from the machine in any direction.
3. Wear sturdy, rough-soled work shoes and close-fitting slacks and shirts. Shirts and pants that cover the arms and legs and steel-toed shoes are recommended. Do not wear loose fitting clothes or jewelry. They can be caught in moving parts. Never operate a unit in bare feet, sandals, or sneakers.
4. Before working with gasoline, extinguish all cigarettes, cigars, pipes and other sources of ignition. Check the fuel level before starting the engine. Gasoline is an extremely flammable fuel. Do not fill the gasoline tank indoors, while the engine is running, or until engine has been allowed to cool for at least two minutes after running. Replace gasoline cap securely and wipe off any spilled gasoline before starting the engine as it may cause a fire or explosion.
5. Disengage the self-propelled mechanism or drive clutch on units so equipped before starting the engine.
6. The blade control handle is a safety device. Never attempt to bypass its operation. Doing so makes the safety device inoperative and may result in personal injury through contact with the rotating blade. The blade control handle must operate easily in both directions and automatically return to the disengaged position when released.
7. Never attempt to make a wheel or cutting height adjustment while the engine is running.
8. Never operate the mower in wet grass. Always be sure of your footing. A slip and fall can cause serious personal injury. Keep a firm hold on the handle and walk, never run. Mow only in daylight or in good artificial light.



### OPERATION

1. Do not change the engine governor settings or overspeed the engine. Excessive engine speeds are dangerous.
2. Do not put hands or feet near or under rotating parts. Keep clear of the discharge opening at all times as the rotating blade can cause injury.
3. Stop the blade when crossing gravel drives, walks or roads.
4. After striking a foreign object, stop the engine, remove the wire from the spark plug, and thoroughly inspect the mower for any damage. Repair the damage before restarting and operating the mower.
5. If the equipment should start to vibrate abnormally, stop the engine and check immediately for the cause. Vibration is generally a warning of trouble.
6. Shut the engine off and wait until the blade comes to a complete stop before removing the grass catcher or unclogging the chute. The cutting blade continues to rotate for a few seconds after engine is shut off. Never place any part of the body in the blade area until you are sure the blade has stopped rotating.
7. Before cleaning, repairing or inspecting, make certain the blade and all moving parts have stopped. Disconnect the spark plug wire, and keep the wire away from the spark plug to prevent accidental starting.
8. Do not run the engine indoors.
9. Never cut grass by pulling mower toward you. Mow across the face of slopes, never up-and-down. Exercise extreme caution when changing direction on slopes. Do not mow excessively steep slopes. Always be sure of your footing. A slip and fall can cause serious personal injury.
10. Never operate mower without proper guards, plates or other safety protective devices in place.
11. Muffler and engine become hot and can cause a burn. Do not touch.



### MAINTENANCE AND STORAGE

1. Check the blade and engine mounting bolts at frequent intervals for proper tightness. Also visually inspect blade for damage (e.g. bent, cracked). Replace with blade which meets original equipment specifications.
2. Keep all nuts, bolts, and screws tight to be sure the equipment is in safe working condition.
3. Never store the mower with gasoline in the tank or gas containers inside of a building where fumes may reach an open flame or spark (e.g. gas hot water heater). Allow the engine to cool before storing in any enclosure.
4. To reduce fire hazard, keep the engine free of grass, leaves and excessive oil.
5. Check the grass catcher bag frequently for wear or deterioration. Replace a worn or damaged bag immediately. For safety protection, replace only with new bag meeting original equipment specifications.

USE THIS SHEET AS A GUIDE TO DETERMINE SLOPES WHERE YOU MAY NOT OPERATE SAFELY.

# SLOPE GAUGE

(Keep this sheet in a safe place for future reference.)

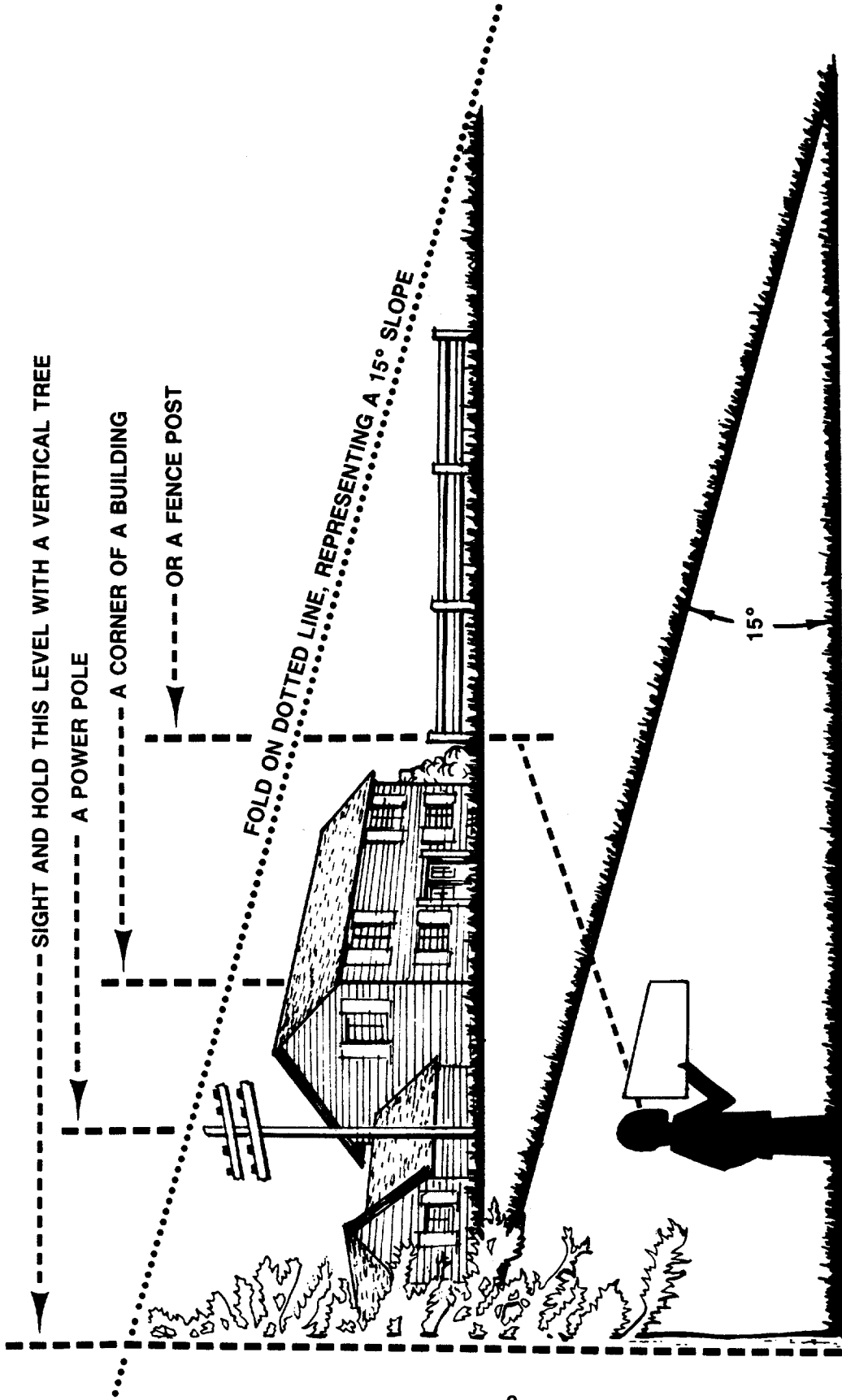

Do not mow on inclines with a slope in excess of 15 degrees (a rise of approximately 2½ feet every 10 feet). A riding mower could overturn and cause serious injury. If operating a walk-behind mower on such a slope, it is extremely difficult to maintain your footing and you could slip, resulting in serious injury.

Operate RIDING mowers up and down slopes, never across the face of slopes.

Operate WALK-BEHIND mowers across the face of slopes, never up and down slopes.

# CONTENTS OF HARDWARE PACK

Remove this sheet from your owner's manual and lay the hardware on the illustration for identification purposes. After assembly, keep the Slope Gauge which is on the reverse side of this sheet for future use.

(Hardware pack may contain extra items which are not used on your unit—  
Part numbers are shown in parentheses.)

**A ATTACHING THE LOWER HANDLE**

Hairpin Clips (714-0104)

**B ATTACHING THE UPPER HANDLE**

Curved Head Bolts (710-0671)  
Split Washers 5/16" I.D. (736-0119)

Rope Guide (710-1205)

Hex Lock Nut 1/4-20 Thread (712-0324)

Cable Bracket (17174)

Spring Washer 1/4" I.D. (736-0175)

Hex Bolt 1/4-20 x 1-7/8" Long (710-1216)

Hex Bolt 1/4-20 x 1" Long (710-0597) (Used With No Remote Throttle)

Hex Nut 1/4-20 Thread (712-0287)

Blade Control Handle

Throttle Control (Optional)

Upper Handle

Rope Guide

Lower Handle

Handle Mounting Brackets

Starter Rope

Engine

Spark Plug

Chute Deflector

(Models 072R and 082R Shown)

**PARTS IDENTIFICATION**

**E SECURING THE CABLES**

Cable Ties (726-0240)



Cut All

This Line

# ASSEMBLY INSTRUCTIONS

This owner's guide covers various models of mowers. Follow only those instructions which pertain to your unit.

**IMPORTANT:** This unit is shipped **WITHOUT GASOLINE** or **OIL**. After assembly, service engine with gasoline and oil as instructed in the separate engine manual packed with your unit.

**NOTE:** Reference to right or left hand side of the mower is observed from the operating position.

## Tools Required for Assembly

- (1) Pair of Pliers
- (1) 1/2" Wrench\*
- (2) 7/16" Wrenches\*
- \*Or two 6" Adjustable Wrenches

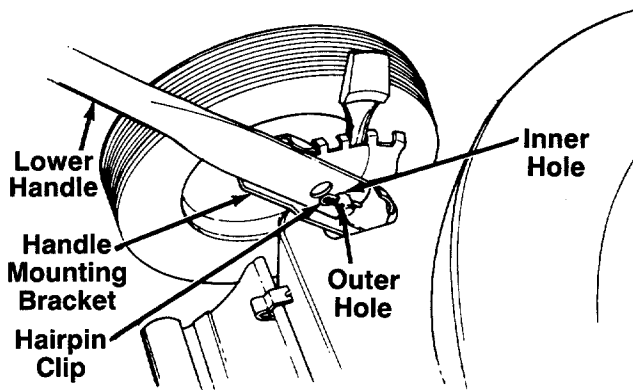

FIGURE 1.

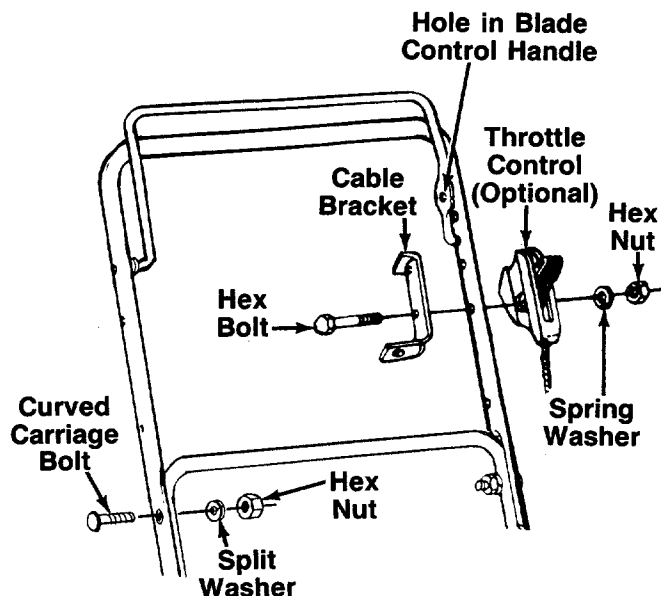

FIGURE 2.

## UNPACKING

1. Remove the lawn mower from the carton by opening the top flaps and lifting the unit out. Be careful of the staples. Make certain all parts and literature have been removed from the carton before the carton is discarded.
2. Disconnect the spark plug wire and move away from the spark plug.
3. Stretch out all control cables and place on the floor. Be careful not to bend or kink the cables at any time during assembly.
4. Remove page four from this manual and lay the contents of the hardware pack on the illustration for identification.

## ATTACHING THE LOWER HANDLE (Hardware A)

1. Attach the lower handle by placing the bottom holes in the lower handle over the weld pins on the handle mounting brackets extending through the rear of the deck.
2. Using a pair of pliers, squeeze one leg of the lower handle against the handle mounting bracket. Insert the hairpin clip into the **inner** hole on the weld pin. See figure 1. Repeat on other side.

**NOTE:** There are two (2) holes in the handle mounting brackets. Place the hairpin clip in the inner hole for operation. Outer hole is for storage.

## ATTACHING THE UPPER HANDLE (Hardware B)

1. Place the upper handle in position over the lower handle. The hole in the side of the blade control handle (attached to the upper handle) must be on the **left** side.
2. Secure the upper handle to the lower handle using the curved head bolts, split washers and hex nuts as shown in figure 2.

## ATTACHING THE CABLE BRACKET AND THROTTLE CONTROL (Hardware D) (Optional)

If your mower is equipped with a remote throttle control, it is already attached to the engine. Attach the cable bracket and throttle control to the **left** side of upper handle as follows. See figure 2.

**NOTE:** If your mower does not have a remote throttle control, attach the cable bracket using the 1" long hex bolt provided and following steps 2 and 4 only.

1. Route the throttle control cable inside the handle mounting bracket and beneath the lower handle.
2. Place cable bracket against left side of upper handle, lining up the hole in the bracket with the bottom hole in upper handle. Place 1/4" hex bolt through cable bracket and handle, from the inside to the outside.
3. Place throttle control on the hex bolt (outside of the upper handle), with the throttle lever facing upward.

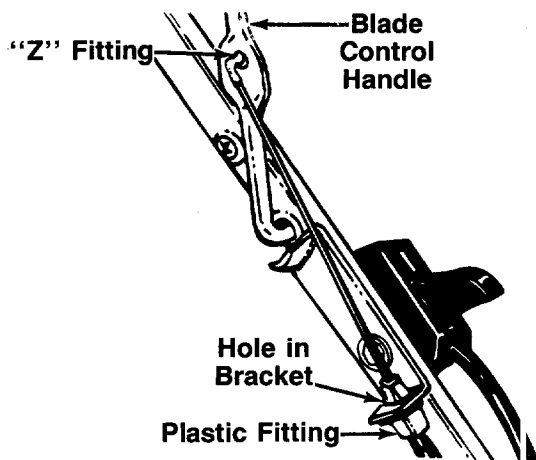

FIGURE 3.

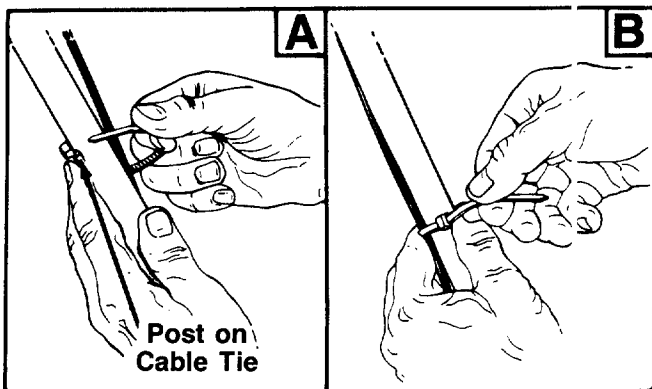

FIGURE 4.

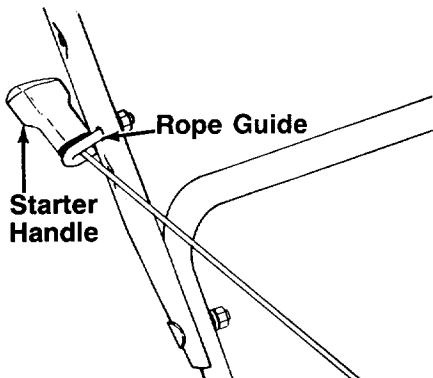

FIGURE 5.

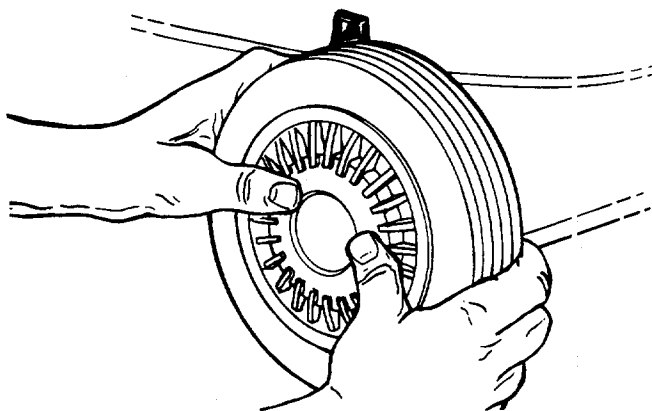

FIGURE 6.—Optional Hub Caps

4. Secure with spring washer (cupped side against the throttle control) and hex nut.

### ATTACHING THE BRAKE CABLE

1. The brake cable is attached to the engine, and has a "Z" fitting on the loose end. Route the brake cable below the lower handle. Place end of cable through the hole in the bracket as shown in figure 3.
3. Push the plastic fitting until it locks into the hole in the bracket.



**WARNING: Brake cable must be assembled as shown for proper blade brake operation.**

2. Hook the "Z" end of the brake cable into the hole in the blade control handle from the inside to the outside as shown in figure 3.

### SECURING THE CABLES (Hardware E)

Secure all cables to the left side of the handle as follows.

1. Insert posts on cable ties into holes provided on the handles, one on the upper handle and two on the lower handle. The holes may be either on the inside or outside of the handles. See figure 4A.
2. Secure the cables with the cable ties. See figure 4B.
3. Trim excess ends of cable ties.

### ATTACHING THE STARTER ROPE (Hardware C)

1. The starter rope is inside the top of the engine. Additional rope may be wound around the starter handle. If so, unwind the rope from the handle.
2. With the spark plug wire disconnected and grounded, depress the blade control handle and pull the rope out of the engine.

3. Place the rope guide around the starter handle, so the rope guide is positioned as shown (bends downward slightly). Insert the rope guide through the side of the upper handle, and secure with hex lock nut.

### INSTALLATION OF HUB CAPS (Optional)

1. If your mower is equipped with hub caps which have four tabs, line up the tabs on the hub caps with the holes in the wheels. Push to lock in position.
2. If your mower is equipped with 2" wide tires, place hub caps in position against the inner hub of the wheel. Press firmly around the center portion of hub cap in a circular motion, similar to installing a lid on a round, plastic container. See figure 6. The hub caps are flexible and will snap over the 3 1/2" diameter wheel hubs.

**NOTE:** It may be helpful to place the hub caps in hot tap water for several minutes to make them pliable before installing, especially if the temperature is less than 60°F.

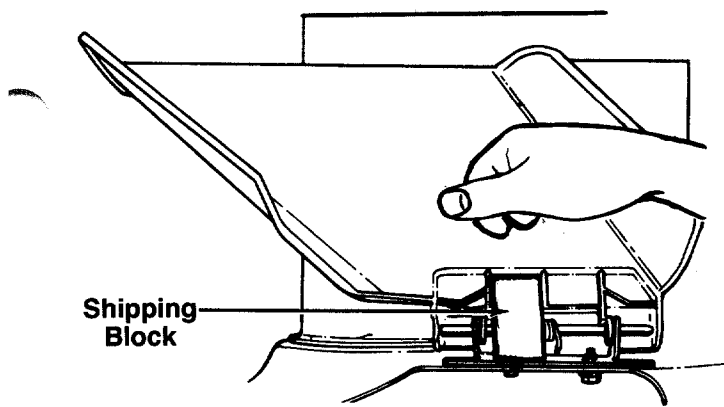

FIGURE 7.

## FINAL ASSEMBLY OF MOWER

1. The chute deflector on your mower is held in an upright position by a block for shipping purposes only. This shipping block must be removed and discarded before the mower is put into operation. See figure 7.

To remove the shipping block, move the spring-loaded chute toward the engine by pushing above the shipping block. Remove the block and carefully lower the chute into operating position, keeping fingers out of the way.

2. Make certain **all** nuts and bolts are tightened securely.

---

## CONTROLS

---

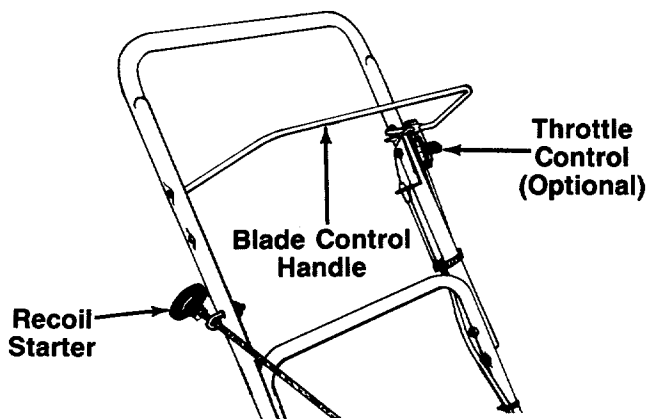

FIGURE 8.

The blade control handle is located on the upper handle of the mower. See figure 8. The blade control handle must be depressed in order to operate the unit. Release the blade control handle to stop the engine and blade.



**WARNING:** The blade will be rotating whenever the engine is running.

### THROTTLE CONTROL (Optional)

The throttle control is located on the side of the upper handle or on the engine. It is used to regulate the engine speed.



**WARNING:** The throttle control cannot be used to stop the engine.

### BLADE CONTROL HANDLE



**WARNING:** This control mechanism is a safety device. Never attempt to bypass its operations.

### RECOIL STARTER

The recoil starter handle is attached to the handle. See figure 8. Stand behind the unit in the operating position to start the unit.

## OPERATION



FIGURE 9.

Keep hands and feet away from the chute area on cutting deck. See figure 9.

The operation of any lawn mower can result in foreign objects being thrown into the eyes, which can result in severe eye damage. Always wear safety glasses or eye shields. We recommend wide vision safety mask for over spectacles or standard safety glasses.



**NOTE:** For shipping purposes your mower is set with the wheels in a low cutting height position. For best results raise the cutting position until it is determined which height is best for your lawn. See cutting height adjustment section.

### GAS AND OIL FILL-UP

Service the engine with gasoline and oil as instructed in the separate engine manual packed with your mower. Read instructions carefully.



**WARNING:** Never fill fuel tank indoors, with engine running or until the engine has been allowed to cool for at least two minutes after running.

### TO START ENGINE AND ENGAGE BLADE

1. Attach spark plug wire to spark plug. If unit is equipped with a rubber boot over the end of the spark plug wire, make certain the metal loop on the end of the spark plug wire (inside the rubber boot) is fastened securely over the metal tip on the spark plug. See figure 10.

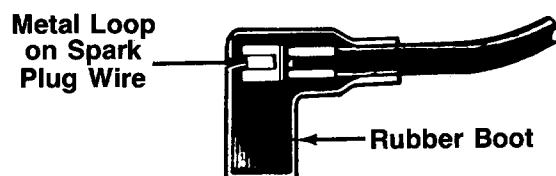

FIGURE 10.

2. Open fuel shut-off valve if so equipped. Refer to the separate engine manual.
3. Move throttle control lever all the way forward.
4. **Tecumseh engines only:** Prime engine as instructed in the separate engine manual.
5. Standing behind the unit, depress the blade control handle and hold it against the upper handle as shown. See figure 11.
6. Grasp the recoil starter handle and pull back rapidly, extending rope fully. Return it slowly to the rope guide bolt.
7. After engine starts, move throttle control to desired engine speed.

**NOTE:** If any problems are encountered, refer to the Trouble Shooting Guide on page 16.

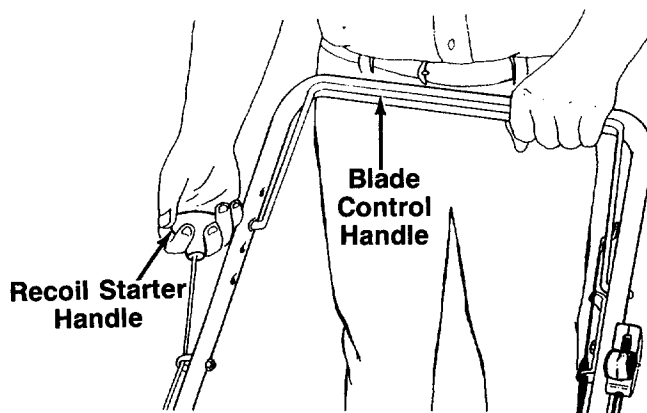

FIGURE 11.

### TO STOP ENGINE AND BLADE

1. Release the blade control handle to stop the engine and blade.



**WARNING:** The blade continues to rotate for a few seconds after the engine is shut off.

2. Disconnect the spark plug wire and ground it against the engine to prevent accidental starting while equipment is unattended.



## USING YOUR ROTARY MOWER

Be sure that lawn is clear of stones, sticks, wire, or other objects which could damage lawn mower or engine. Such objects could be accidentally thrown by the mower in any direction and cause serious personal injury to the operator and others.

For the best results, do not cut wet grass because it tends to stick to the underside of the mower, preventing proper discharge of grass clippings, and could cause you to slip and fall. New grass, thick grass or wet grass may require a narrower cut. Blade speed should be adjusted to the condition of the lawn.

The best mowing pattern is one that allows the clippings to discharge towards the uncut part of the lawn. This permits recutting of the clippings to further pulverize them. When cutting high weeds, discharge towards cut portion, then recut at right angles to first direction.

For best results, cut off one-third or less of the total length of the grass. Lawn should be cut in the fall as long as there is growth.

This mower is designed to be operated at full throttle to give you the best cut and do the most effective job of bagging the cut grass.



**WARNING:** If you strike a foreign object, stop the engine. Remove wire from spark plug, thoroughly inspect the mower for any damage, and repair the damage before restarting and operating the mower. Extensive vibration of the mower during operation is an indication of damage. The unit should be promptly inspected and repaired.

---

## ADJUSTMENTS

---



**WARNING:** Do not at any time make any adjustment to lawn mower without first stopping engine and disconnecting spark plug wire.

### CUTTING HEIGHT ADJUSTMENT

An adjusting plate and thumb lever at each wheel position provides cutting height adjustment. Each adjusting plate has nine height positions. Height of cut will be changed when the thumb lever is moved from one hole to another. Simply depress the lever towards wheel and move wheel and lever assembly to desired position. All wheels must be placed in the same relative position. See figure 12.

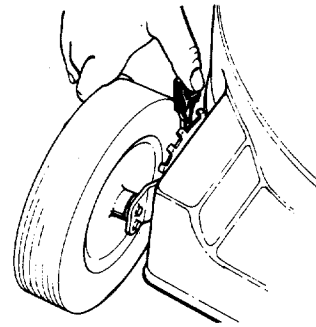

FIGURE 12.

### THROTTLE CONTROL ADJUSTMENT

If the throttle control (optional) needs adjustment or if it has been replaced, adjust as follows.

#### Briggs & Stratton Quantum Engines:

1. Remove the screw shown in figure 13. Remove the cable clamp from the cable.
2. Push the throttle control lever on the handle all the way forward to CHOKE position. Make certain the throttle control lever remains in this position.
3. Push the control lever on the engine as far toward the rear of the engine as it will go. Secure the cable in this position with the cable clamp and screw.

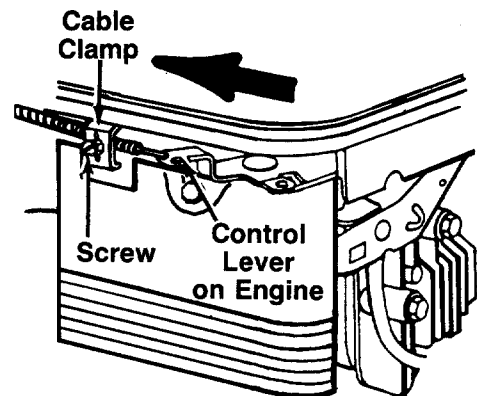

FIGURE 13.—Briggs & Stratton Quantum Engines

#### Briggs & Stratton Standard and Sprint Engines and all Tecumseh Engines (all other models):

1. Loosen (do not remove) the screw on the cable clamp so that the cable will move freely under the clamp. See figure 14.
2. Place the throttle control lever on the handle all the way forward to START position.
3. Place the control lever on the engine in the full open position by pushing it as far toward the outside (Briggs and Stratton engine) or rear (Tecumseh engine) of the engine as it will go. Tighten the screw on the cable clamp to secure the cable in this position.

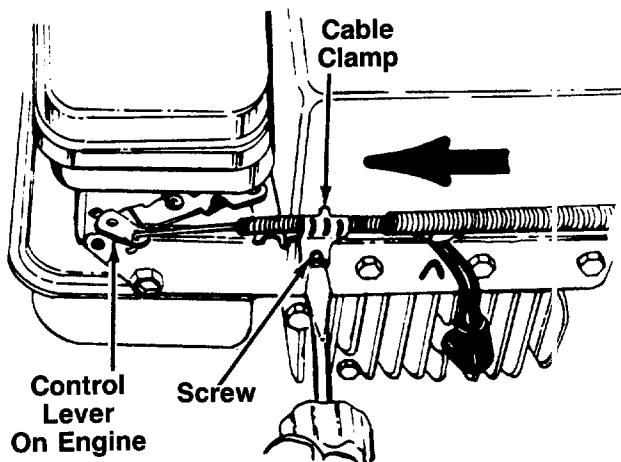

FIGURE 14A.—Briggs & Stratton Standard Engine

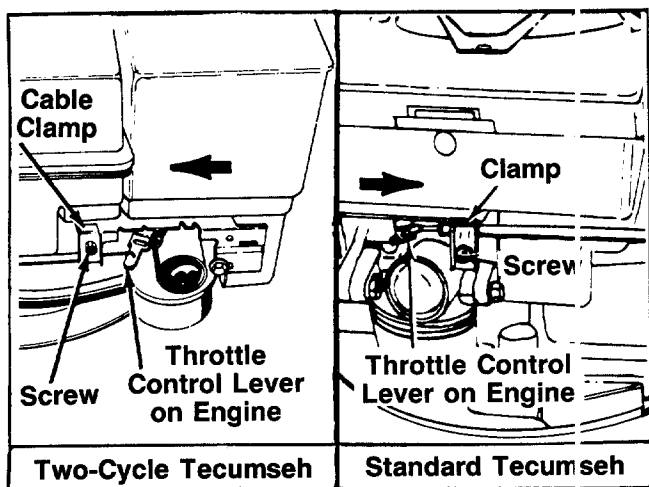

FIGURE 14B.—Tecumseh Engines

### CARBURETOR ADJUSTMENTS



**WARNING:** If any adjustments are made to the engine while the engine is running (e.g. carburetor), keep clear of all moving parts. Be careful of heated surfaces and muffler.

Minor carburetor adjustments may be required to compensate for differences in fuel, temperature, altitude and load. To adjust carburetor, refer to the separate engine manual packed with your mower.

**NOTE:** A dirty air cleaner will cause an engine to run rough. Be certain air cleaner is clean and attached to the carburetor before adjusting carburetor. Refer to the separate engine manual.

## LUBRICATION



**WARNING:** Always stop engine and disconnect spark plug wire before cleaning, lubricating or doing any kind of work on lawn mower.

**Blade Control**—Lubricate the pivot points on the blade control handle and the brake cable at least once a season with light oil. See figure 15. The blade control must operate freely in both directions.

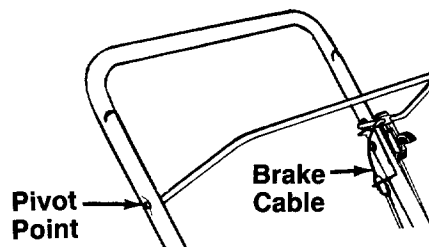

FIGURE 15.

**Chute Deflector**—The torsion spring and pivot point should be lubricated periodically with light oil to prevent any rust or binding. Deflector must work freely.

**Wheels**—Mower may be provided with ball bearing wheels. Lubricate at least once a season with light oil. Also, if the wheels are removed for any reason, lubricate the surface of the axle bolt and the inner surface of the wheel with light oil. A 4 oz. plastic bottle of light oil lubricant is available. Order part number 737-0170. Engine oil may also be used.

**Engine**—Follow engine manual for lubrication instructions.

**Throttle**—Periodically lubricate throttle control lever and throttle wire assembly with a few drops of light oil for ease of operation.

## MAINTENANCE



**WARNING:** Be sure to disconnect and ground the spark plug wire before performing any repairs or maintenance.

**NOTE:** When tipping the unit, empty the fuel tank and keep engine spark plug side up.

### TROUBLE SHOOTING

Refer to page 16 of this manual for trouble shooting information.

### CUTTING BLADE

When removing the cutting blade for sharpening or replacement, protect hands by using heavy gloves or a rag to grasp the cutting blade. Remove the bolt and bell washer which hold the blade and adapter to the engine crankshaft. Remove the blade and adapter from the crankshaft.

If the blade or blade adapter needs replacing, remove the two small bolts, lock washers and nuts which hold the blade to the adapter.



**WARNING:** Periodically inspect the blade adapter for cracks, especially if you strike a foreign object. Replace when necessary.

When sharpening the blade, follow the original angle of grind as a guide. It is **extremely important** that each cutting edge receives an equal amount of grinding to prevent an unbalanced blade. An unbalanced blade will cause excessive vibration when rotating at high speeds, may cause damage to the mower and could break, causing personal injury.

It is recommended that the blade always be removed from the adapter for the best test of balance.

The blade can be tested by balancing it on a round shaft screwdriver. Remove metal from the heavy side until it balances evenly.

Before reassembling the blade and the blade adapter to the unit, lubricate the engine crankshaft and the inner surface of the blade adapter with light oil. Lubricating the bolt holes, bolts and inner surface of the nuts with light oil is also recommended. A 4 oz. plastic bottle of light oil lubricant is available. Order part number 737-0170. Engine oil may also be used.

When replacing the blade, be sure to install the blade with the side of the blade marked "Bottom" (or with part number) facing the ground when the mower is in the operating position.

#### **Blade Mounting Torque**

Center Bolt and Blade Adapter Bolts:  
375 in. lb. min., 450 in. lb. max.

To insure safe operation of your unit, **all** nuts and bolts must be checked periodically for correct tightness.

#### **DECK**

The underside of the mower deck should be cleaned after each use to prevent a buildup of grass clippings, leaves, dirt or other matter. If this debris is allowed to accumulate, it will invite rust and corrosion, and may cause an uneven discharge of grass clippings at the next cutting.

The deck may be cleaned by tilting the mower and scraping clean with a suitable tool (make certain the spark plug wire is disconnected).

#### **ENGINE**

**Refer to the separate engine manual for engine maintenance instructions.**

Maintain **engine oil** as instructed in the separate engine manual packed with your unit. Read and follow instructions carefully.

Service **air cleaner** every 25 hours under normal conditions. Clean every few hours under extremely dusty

conditions. Poor engine performance and flooding usually indicates that the air cleaner should be serviced. To service the air cleaner, refer to the separate engine manual packed with your unit.

The **spark plug** should be cleaned and the gap reset once a season. Spark plug replacement is recommended at the start of each mowing season; check engine manual for correct plug type and gap specifications.

**Clean the engine** regularly with a cloth or brush. Keep the cooling system (blower housing area) clean to permit proper air circulation which is essential to engine performance and life. Be certain to remove all grass, dirt and combustible debris from muffler area.

---

## **OFF-SEASON STORAGE**

---

The following steps should be taken to prepare lawn mower for storage.

1. Clean and lubricate mower thoroughly as described in the lubrication instructions.
2. Refer to engine manual for correct engine storage instructions.
3. Coat mower's cutting blade with chassis grease to prevent rusting.
4. Store mower in a dry, clean area.

**NOTE:** *When storing any type of power equipment in an unventilated or metal storage shed, care should be taken to rust-proof the equipment. Using a light oil or silicone, coat the equipment, especially cables and all moving parts.*

---

## **HANDLE STORAGE**

---

The handle may be placed in an upright position for storage. Move hairpin clips to outer hole on weld pins. See figure 1. Press inward on the bottom of the lower handle and push forward. The handle will lock in this position.

To place the handle in the operating position, remove the starter rope from the rope guide bolt. Grasp the lower handle at the bottom, press inward slightly and tip the handle backward. Place the hairpin clips in the inner holes. With the spark plug wire disconnected and grounded, depress the blade control handle and pull the starter rope out from the engine. Slip the starter rope into the rope guide bolt.

**NOTE:** The use of any accessory on this Rotary Mower other than those manufactured by the mower manufacturer is **not** recommended. GRASS CATCHER Model 086 is available as optional equipment for the mowers shown in this manual.



**WARNING:** To reduce the risk of injury, do not operate mower unless rear trailing shield and guard or entire grass catcher is in its proper place.

**NOTE:** Under normal usage bag material is subject to wear and should be checked periodically. Be sure any replacement bag complies with the mower manufacturer's recommendations. For replacement bags, use only factory authorized replacement bag No. 764-0271.

# Models 070R thru 089R

\*For faster service obtain standard nuts, bolts and washers locally. If these items cannot be obtained locally, order by part number and size as shown on parts list.

CODE: N notates a new part (not previously existing). A three digit number is the color code. Specify color code if color or finish is important when ordering parts as shown below. [i.e., 638 for Red Finish].

### Color Codes

456—Radiant Tangerine	629—Silver Flake
460—Green Flake	630—Metallic Blue
483—Charcoal Gray	637—Black
498—Yellow	638—Red
499—Beige	640—Green
621—Brilliant Fire Mist	646—CM Blue

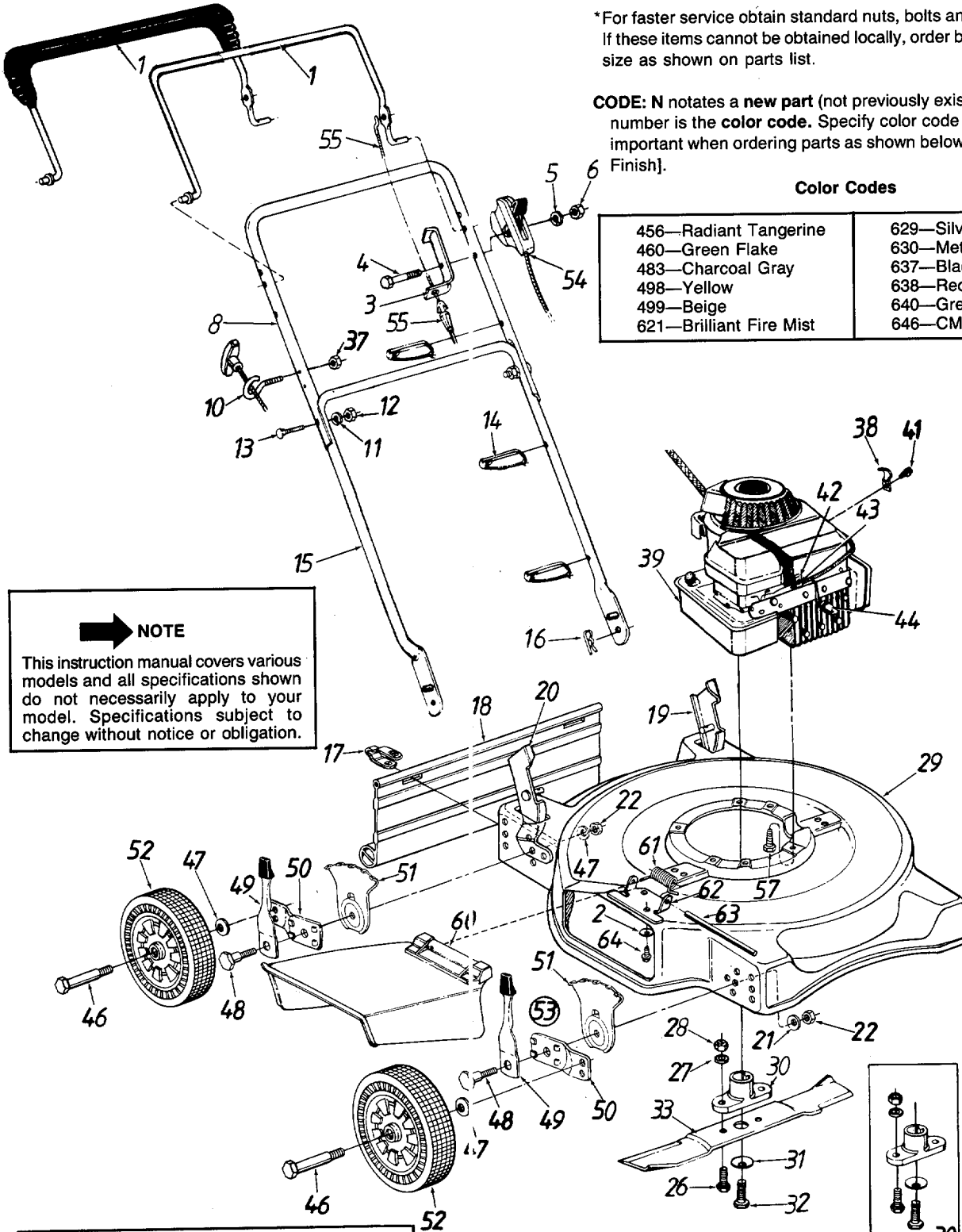

### NOTE

This instruction manual covers various models and all specifications shown do not necessarily apply to your model. Specifications subject to change without notice or obligation.

NOTE: The engine is not under warranty by the mower manufacturer... If repairs or service is needed on the engine, please contact your nearest authorized engine service outlet. Check the "Yellow Pages" of your telephone book under "Engines—Gasoline."

Find It Fast  
In The  
Yellow Pages

### Optional Hub Caps

Description	Part No.
Gray (for "S" Wave Wheels)	731-0981A
Beige (for "S" Wave Wheels)	731-0982A
Red (with 4 tabs)	731-0124
Black (with 4 tabs)	731-0354

**PARTS LIST FOR MODELS 070R THRU 089R ROTARY MOWERS**

REF. NO.	PART NO.	CODE	DESCRIPTION	REF. NO.	PART NO.	CODE	DESCRIPTION
1	747-0748		Control Handle Ass'y. (Std.)	41	710-0429		Hex B-Tap Scr. #10 x .38"†
	731-1135		Control Handle Ass'y. w/Plastic	42	751-0369		Cable Clamp†
2	736-0270		Bell-Wash. 1/4" I.D.	43	710-0227		Hex AB-Tap Scr. #8 x .38"†
3	17174		Cable Brkt.	44	735-0639		Spark Plug Boot (Optional)
4	710-1216	N	Hex Bolt 1/4-20 x 1.875" Lg.*	46	**		Axle Bolt
	710-0597		Hex Bolt 1/4-20 x 1" Lg.*	47	736-0105		Bell-Wash. .400" I.D. x .88"
			(Used without Throttle Control)	48	738-0507B		Shld. Bolt .50" Dia. x .357"
5	736-0175		Spr. Wash. 1/4" I.D.	49	14832		Spring Lever Ass'y. w/Knob
6	712-0287		Hex Nut 1/4-20 Thd.*	50	15262B		Pivot Bar
8	749-0756A		Upper Handle	51	15261A		Height Adj. Plate
10	747-1205	N	Rope Guide	52	**		Wheel Ass'y. Comp.
11	736-0119		L-Wash. 5/16" I.D.*	53	14578		Height Adj. Ass'y. Comp.—
12	712-0267		Hex Nut 5/16-18 Thd.*				R.F. & L.R.
13	710-0671		Curved Carriage Bolt 5/16-18		14579		Height Adj. Ass'y. Comp.—
			x 1.38" Lg.				L.F. & R.R.
14	726-0240		Cable Tie	54	746-0801		Throttle Control Ass'y. Comp.—
15	749-0372B		Lower Handle				51.62"†
16	714-0104		Hairpin Cotter		746-0820		Throttle Control Ass'y. Comp.—
17	17098		Hinge Clip				49.62"††
18	731-0872		Rear Flap		746-0830		Throttle Control Ass'y. Comp.—
19	17189		Handle Bracket Ass'y.—L.H.				38.62" (071R, 073R, 075R,
20	17188		Handle Bracket Ass'y.—R.H.				079R)
21	736-0356		Bell-Wash. .39" I.D. x 1.38"		746-0831		Throttle Control Ass'y. Comp.—
22	712-0798		Hex Nut 3/8-16 Thd.*				41.62" (081R, 083R, 085R,
26	710-1055		Hex Bolt 3/8-24 x 1" Lg.*				089R)
27	736-0169		L-Wash. 3/8" I.D.*		746-0832		Throttle Control Ass'y. Comp.—
28	712-0241		Hex Nut 3/8-24 Thd.*				45.62" (077R, 087R)
29	17036	638	20" Deck Ass'y.	55	746-0553	0732	Control Cable—36" (070R,
	17046	638	22" Deck Ass'y.				072R, 074R, 076R, 078R,
30	753-0484		Blade Adapter Kit (Keyed)				084R, 086R, 088R)
	753-0485		Blade Adapter Kit (Splined)		746-0550		Control Cable—39"
31	736-0452		Bell-Wash. .39" I.D. (Used				(080R, 082R)
			w/Keyed Adapter)		746-0557		Control Cable—47"
	736-0453		Bell-Wash. .46" I.D. (Used				(077R, 087R)
			w/Splined Adapter)		746-0552		Control Cable—49" (071R,
32	710-1044		Hex Bolt 3/8-24 x 1.5" Lg.				073R, 075R, 079R, 081R,
			(Used w/Keyed Adapter)				083R, 085R, 089R)
	710-0757		Hex Bolt 7/16-20 x 1.5" Lg.	57	710-0654A		Hex L-Wash. Hd. Scr.
			(Used w/Splined Adapter)				3/8-16 x 1.0" Lg.
33	742-0520		20" Blade	60	731-1034		Chute Deflector Ass'y.
	742-0522		22" Blade	61	732-0593		Torsion Spring
37	712-0324		Hex L-Nut 1/4-20 Thd.	62	17032		Adapter Plate
38	12894A		Cable Clamp†	63	747-0710		Hinge Pin
39	—		Engine	64	710-0599		Hex Self-Tap Scr. 1/4-20 x .5" Lg.

†Models 070R, 072R, 080R & 082R Only

††Models 074R, 076R, 078R, 084R, 086R & 088R Only

**\*\*WHEEL CHART**

Wheels w/o Bearings			Wheels With Bearings			
Tread***	Ass'y. Comp.	Axle Bolt	Tread***	Ass'y. Comp.	Bearings	Axle Bolt
Waffle	734-1162A (8") 734-1161A (7")	738-0102 738-0102	Waffle	734-0645 734-0924 734-0812	Ball Brgs.: 3/8" I.D.-741-0267, 1/2" I.D.-741-0484, Spacer-750-0434 Ball Brg. 1/2" I.D.-741-0180 (2 per Wheel) Plastic Brg. 1/2" I.D.-741-0262 (2 per Wheel)	710-1020 738-0102 738-0102
Rib	734-1169 (8") 734-1170 (7")	738-0144 738-0144	"T" Tread	734-1259 734-1260	Ball Brgs.: 3/8" I.D.-741-0267, 1/2" I.D.-741-0484, Spacer-750-0434 Ball Brg. 1/2" I.D.-741-0180 (2 per Wheel)	710-1020 738-0102
Bar	734-1608 (8")	738-0102	"S" Wave	734-1513A	Ball Brg. 1/2" I.D.-741-0180 (2 per Wheel)	738-0102

\*\*\*Tread Type: Waffle  ; Rib  ; Bar  ; "T" Tread  ; "S" Wave 

# Models 200R thru 226R

\*For faster service obtain standard nuts, bolts and washers locally. If these items cannot be obtained locally, order by part number and size as shown on parts list.

**CODE: N** notates a **new part** (not previously existing). A three digit number is the **color code**. Specify color code if color or finish is important when ordering parts as shown below. [i.e., 638 for Red Finish].

NOTE: The engine is not under warranty by the mower manufacturer. . . If repairs or service is needed on the engine, please contact your nearest authorized engine service outlet. Check the "Yellow Pages" of your telephone book under "Engines—Gasoline."



## \*\*Optional Hub Caps

Description	Part No.
Gray (5-1/2" Dia.)	731-0981A
Beige (5-1/2" Dia.)	731-0982A
Gray (3-1/2" Dia.)	720-0249
Black (1-1/2" Dia.)	720-0251
Red (1-3/8" Dia.)	731-0342

**NOTE**  
Specifications subject to change without notice or obligation.

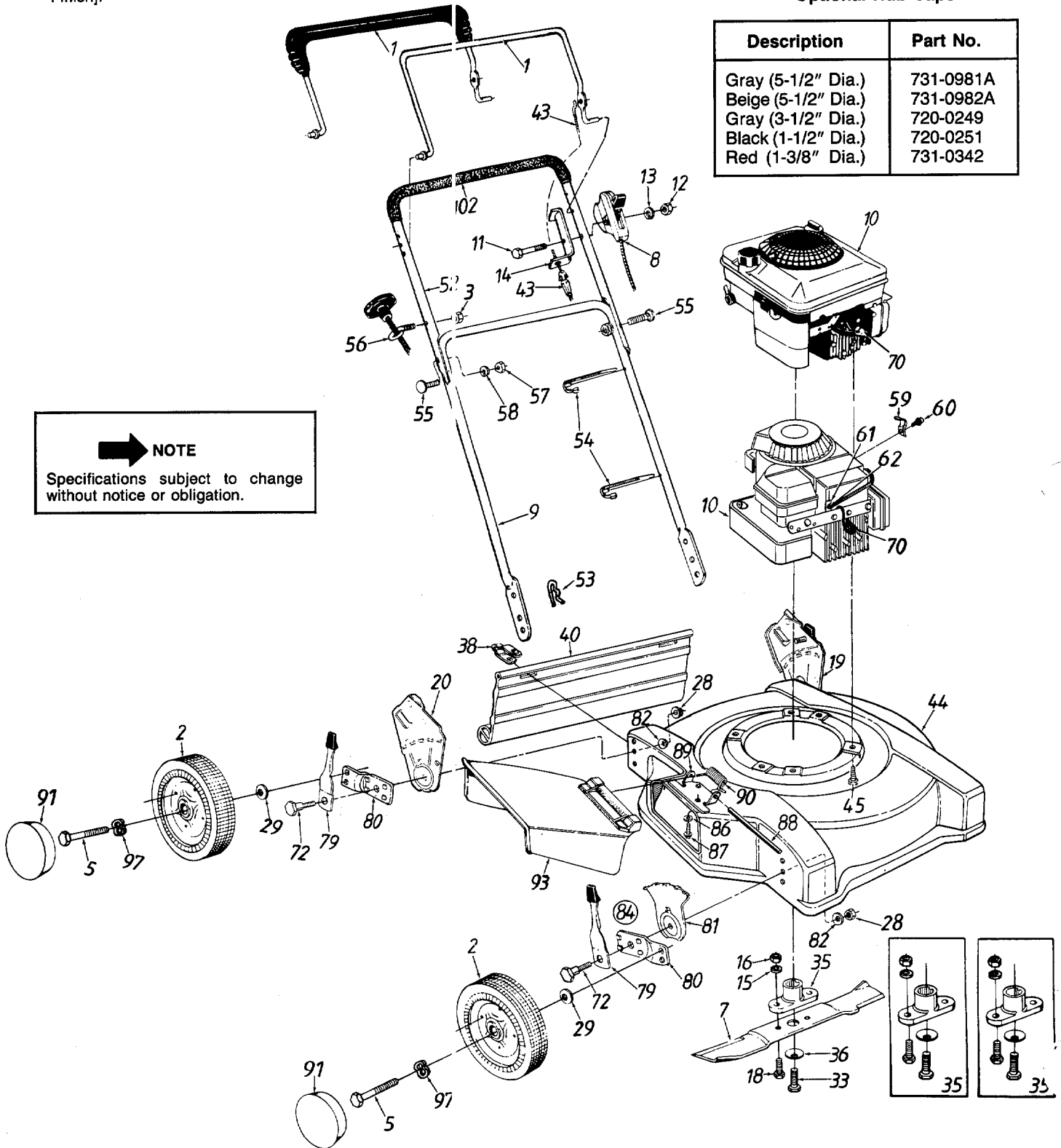

# Models 200R thru 226R

## PARTS LIST FOR MODELS 200R THRU 226R ROTARY MOWERS

REF. NO.	PART NO.	CODE	DESCRIPTION	REF. NO.	PART NO.	CODE	DESCRIPTION
1	747-0748		Control Handle Ass'y. (Std.)	44	682-0200	638/N	20" Deck Ass'y.
2	731-1135		Control Handle Ass'y. w/Plastic Wheel Ass'y.—Comp.	45	682-0220	638/N	22" Deck Ass'y.
3	712-0324		Hex L-Nut 1/4-20 Thd.	52	710-0654A		Hex Wash. Hd. TT-Tap Scr. 3/8-16 x 1.00" Lg.
5	**		Axle Bolt	53	749-0756A		Upper Handle
7	742-0520		20" Blade	54	714-0104		Intern. Cot. Pin 5/16" Dia.
	742-0522		22" Blade	55	726-0240		Cable Tie
8	746-0820	N	Throttle Control Ass'y. Comp.—49.6 (204R, 206R, 224R, 226R)	56	710-0671		Curved Carriage Bolt 5/16-18 x 1.38" Lg.
	746-0801		Throttle Control Ass'y. Comp.—51.62" (200R, 202R, 220R, 222R)	56	710-1205	N	Rope Guide
	0756 746-0830		Throttle Control Ass'y. Comp.—38.52" (203R, 223R)	57	712-0267		Hex Nut 5/16-18 Thd.*
	0815 746-0830		Throttle Control Ass'y. Comp.—38.52" (203R, 223R)	58	736-0119		L-Wash. 5/16" I.D.*
9	749-0372B		Lower Handle	59	12894A		Cable Clamp†
10	—		Engine	60	710-0429		Hex B-Tap Scr. #10 x .38" Lg.†
11	710-1216	N	Hex Bolt 1/4-20 x 1.875" Lg.*	61	751-0369		Cable Clamp†
12	712-0287		Hex Nut 1/4-20 Thd.*	62	710-0227		Hex AB-Tap Scr. #8 x .38" Lg.†
13	736-0175		Spr. Wash. .265" I.D. x .562"	65	** NOT SHOWN		Wheel Bearing SEE CHART BELOW
14	17174		Cable Mtg. Bracket	70	735-0639		Spark Plug Boot (Optional)
15	736-0169		L-Wash. 3/8" I.D.*	72	738-0507B		Shoulder Bolt .50" Dia.
16	712-0241		Hex Nut 3/8-24 Thd.	79	14832		Spring Lever Ass'y. w/Knob
18	710-1055		Hex Bolt 3/8-24 x 1.0" Lg.	80	15262B		Pivot Bar
19	682-3001	N	Wheel Brkt. Ass'y.—L.H.	81	15261A		Height Adj. Plate
20	682-3000	N	Wheel Brkt. Ass'y.—R.H.	82	736-0356		Bell-Wash. .39" I.D. x 1.38"
28	712-0798		Hex Nut 3/8-16 Thd.*	84	14578		Front Height Adj. Ass'y. Comp.—R.H.
29	736-0105		Bell-Wash. .40" I.D. x .88"		14579		Front Height Adj. Ass'y. Comp.—L.H. (Not Shown)
33	710-1044		Hex Bolt 3/8-24 x 1.5" Lg. (Used w/Keyed Adapter)	86	736-0270		Bell-Wash. .285" I.D. x .75" O.D.
	710-0757		Hex Bolt 7/16-20 x 1.5" Lg. (Used w/Splined Adapter)	87	710-0599		Hex Wash. Hd. Tap Scr. 1/4-20 x .5" Lg.
35	753-0484		Blade Adapter Kit (Keyed)	88	747-0710		Hinge Pin
	753-0485		Blade Adapter Kit (Splined)	89	17032		Adapter Plate
36	736-0452		Bell-Wash. .39" I.D. (Used w/Keyed Adapter)	90	732-0593		Torsion Spring
	736-0453		Bell-Wash. .46" I.D. (Used w/Splined Adapter)	91	**		Hub Cap
38	17098		Hinge Clip	93	731-1034		Chute Deflector Ass'y. Comp.
40	731-1028	N	Rear Flap Ass'y.	97	736-0232		Wave Washer .53" I.D. (Used w/Ball Brg. Wheels)
43	746-0553		Control Cable—36" (200R, 202R, 204R, 206R, 220R, 222R, 224R, 226R)	99	736-0272	Not shown	Fl-Wash. .51" I.D. x 1.0"
	0557 746-0727	N	Control Cable—47" (203R, 223R)	102	720-0226		Foam Grip (Optional)

†Models 200R, 202R, 220R & 222R only. 200R 220R 222R  
746-0550 CONT. CABLE—39" (200R) WHEEL CHART

Wheels w/o Bearings			Wheels With Bearings			
Tread***	Ass'y. Comp.	Axle Bolt	Tread***	Ass'y. Comp.	Bearings	Axle Bolt
Diamond	634-004 (7")	738-0102	"S" Wave	734-1513B (Gray)	Ball Brg. 1/2" I.D.-741-0180 (2 per Wheel)	738-0102
	734-1655 (8")	738-0102		734-1517B (Beige)	Ball Brg. 1/2" I.D.-741-0180 (2 per Wheel)	738-0102
Bar	734-1608 (8")	738-0102	Waffle	734-0645	Ball Brgs. 3/8" I.D.-741-0267, 1/2" I.D.-741-0484, Spacer-750-0434	710-1020
"S" Wave	734-1512A (8")	738-0102				
Waffle	734-1162A (8")	738-0102	"T" Tread	734-1259	Ball Brgs. 3/8" I.D.-741-0267, 1/2" I.D.-741-0484, Spacer 750-0434	710-1020
Rib	734-1169 (8")	738-0144		734-1260	Ball Brg. 1/2" I.D.-741-0180 (2 per Wheel)	738-0102

\*\*\*Tread Type: Waffle [diagonal lines]; Rib [horizontal lines]; Bar [vertical lines]; "T" Tread [cross-hatch]; "S" Wave [wavy lines]; Diamond [diamond pattern]

# TROUBLE SHOOTING GUIDE

Trouble	Possible Cause(s)	Corrective Action
Engine fails to start	<ol style="list-style-type: none"> <li>1. Blade control handle disengaged.</li> <li>2. Spark plug wire disconnected.</li> <li>3. Throttle control lever not in CHOKE or START position.</li> <li>4. Fuel shut-off valve closed (if so equipped).</li> <li>5. Fuel tank empty, or stale fuel.</li> <li>6. Blocked fuel line</li> <li>7. Faulty spark plug.</li> <li>8. Engine flooded.</li> </ol>	<ol style="list-style-type: none"> <li>1. Engage blade control handle.</li> <li>2. Connect wire to spark plug.</li> <li>3. Move throttle lever to CHOKE or START position.</li> <li>4. Open fuel shut-off valve.</li> <li>5. Fill tank with clean, fresh gasoline.</li> <li>6. Clean fuel line.</li> <li>7. Clean, adjust gap or replace.</li> <li>8. Remove spark plug, dry the plug, and crank engine with plug removed and throttle in off position. Replace spark plug, connect wire and resume starting procedures.</li> </ol>
Engine runs erratic	<ol style="list-style-type: none"> <li>1. Unit running in CHOKE or START position.</li> <li>2. Spark plug wire loose.</li> <li>3. Blocked fuel line or stale fuel.</li> <li>4. Vent in gas cap plugged.</li> <li>5. Water or dirt in fuel system.</li> <li>6. Dirty air cleaner.</li> <li>7. Carburetor out of adjustment.</li> </ol>	<ol style="list-style-type: none"> <li>1. Move throttle lever to FAST position.</li> <li>2. Connect and tighten spark plug wire.</li> <li>3. Clean fuel line; fill tank with clean, fresh gasoline.</li> <li>4. Clear vent.</li> <li>5. Drain fuel tank. Refill with fresh fuel.</li> <li>6. Clean air cleaner.†</li> <li>7. Adjust carburetor.†</li> </ol>
Engine overheats	<ol style="list-style-type: none"> <li>1. Engine oil level low.</li> <li>2. Air flow restricted.</li> <li>3. Carburetor not adjusted properly.</li> </ol>	<ol style="list-style-type: none"> <li>1. Fill crankcase with proper oil.</li> <li>2. Remove blower housing and clean.†</li> <li>3. Adjust carburetor.†</li> </ol>
Occasional skip (hesitates) at high speed	<ol style="list-style-type: none"> <li>1. Carburetor idle speed too slow.</li> <li>2. Spark plug gap too close.</li> <li>3. Carburetor idle mixture adjustment improperly set.</li> </ol>	<ol style="list-style-type: none"> <li>1. Adjust carburetor.†</li> <li>2. Adjust gap to .030".</li> <li>3. Adjust carburetor.†</li> </ol>
Idles poorly	<ol style="list-style-type: none"> <li>1. Spark plug fouled, faulty or gap too wide.</li> <li>2. Carburetor improperly adjusted.</li> <li>3. Dirty air cleaner.</li> </ol>	<ol style="list-style-type: none"> <li>1. Reset gap to .030" or replace spark plug.</li> <li>2. Adjust carburetor.†</li> <li>3. Clean air cleaner.†</li> </ol>
Excessive vibration	<ol style="list-style-type: none"> <li>1. Cutting blade loose or unbalanced.</li> <li>2. Bent cutting blade.</li> </ol>	<ol style="list-style-type: none"> <li>1. Tighten blade and adapter. Balance blade.</li> <li>2. Replace blade.</li> </ol>
Mower will not discharge grass	<ol style="list-style-type: none"> <li>1. Engine speed too low.</li> <li>2. Wet grass.</li> <li>3. Excessively high grass.</li> </ol>	<ol style="list-style-type: none"> <li>1. Set throttle between 3/4 and full throttle.</li> <li>2. Do not mow when grass is wet; wait until later to cut.</li> <li>3. Mow once at a high cutting height, then mow again at desired height or make a narrower cutting swath (1/2 width).</li> </ol>
Uneven cut	<ol style="list-style-type: none"> <li>1. Wheels not positioned correctly.</li> <li>2. Dull blade.</li> </ol>	<ol style="list-style-type: none"> <li>1. Place all four wheels in same height position.</li> <li>2. Sharpen or replace blade.</li> </ol>

†Refer to separate engine manual packed with your unit.

**Note:** For repairs beyond the minor adjustments listed above, contact your local authorized service dealer.