

\$1.00

OWNER'S GUIDE

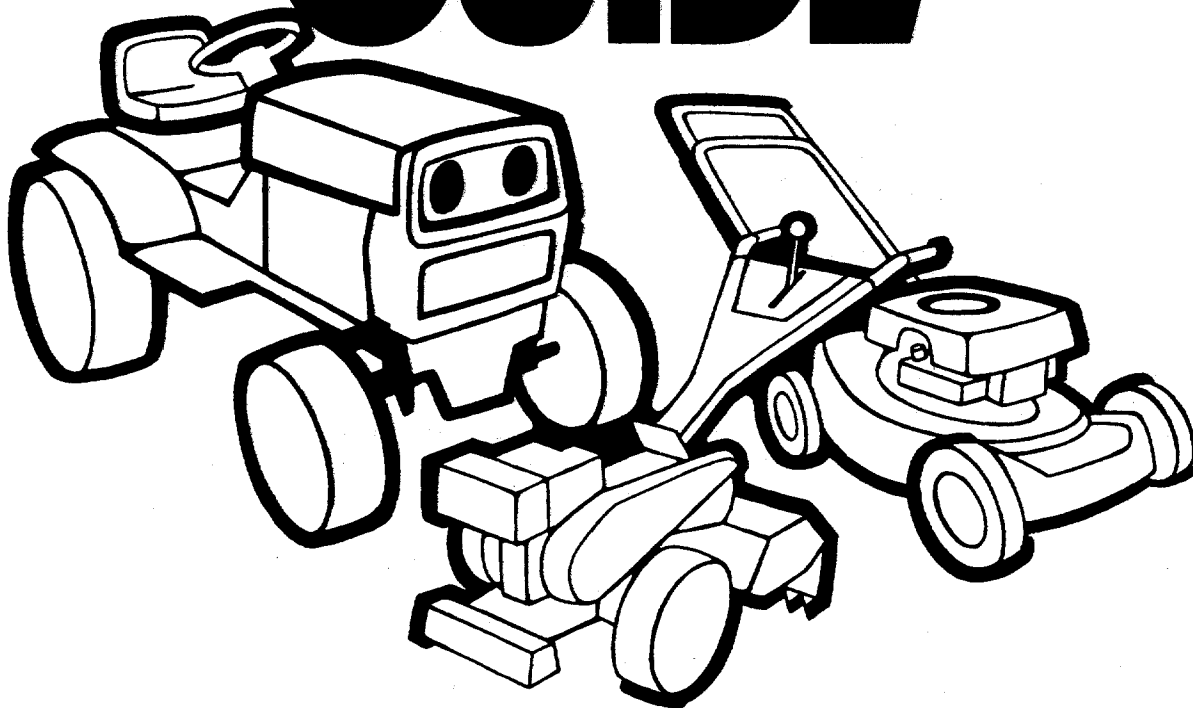

**18"
ROTARY
MOWER**

**Model Number
117-020-000**

IMPORTANT: Read Safety Rules and Instructions Carefully

INDEX

Slope Gauge	3
Contents of Hardware Pack	4
Safe Operation	5
Assembly	6
Controls	9
Operation	10
Adjustments	11
Lubrication	11
Maintenance	12
Off-Season Storage	13
Repair Parts	14, 15
Trouble Shooting Chart	16
Parts Information	Back Cover

Dear Customer,

So often throughout the year we are all in a rush to meet our daily obligations.

However, we at MTD Products Inc are taking a quick moment out to say . . .

"Thank you for your business."

Sincerely,

MTD PRODUCTS INC



INSTRUCTIONS GIVEN WITH THIS SYMBOL ARE FOR PERSONAL SAFETY. BE SURE TO FOLLOW THEM.

LIMITED WARRANTY

For one year from the date of original retail purchase, MTD PRODUCTS INC will either repair or replace, at its option, free of charge, F.O.B. factory or authorized service firm, any part or parts found to be defective in material or workmanship. Transportation charges for the movement of any power equipment unit or attachment are the responsibility of the purchaser. Transportation charges for any parts submitted for replacement under this warranty must be paid by the purchaser unless such return is requested by MTD PRODUCTS INC.

This warranty will not apply to any part which has become inoperative due to misuse, excessive use, accident, neglect, improper maintenance, alterations, or unless the unit has been operated and maintained in accordance with the instructions furnished. This warranty does not apply to the engine, motor, battery, battery charger or component parts thereof. Please refer to the applicable manufacturer's warranty on these items.

This warranty will not apply where the unit has been used commercially.

Warranty service is available through your local authorized service dealer or distributor. If you do not know the dealer or distributor in your area, please write to the Customer Service Department of MTD.

The return of a complete unit will not be accepted by the factory unless prior written permission has been extended by MTD.

This warranty gives you specific legal rights. You may also have other rights which vary from state to state.

WARNING: This unit is equipped with an internal combustion engine and should not be used on or near any unimproved forest-covered, brush-covered or grass-covered land unless the engine's exhaust system is equipped with a spark arrester meeting applicable local or state laws (if any). If a spark arrester is used, it should be maintained in effective working order by the operator.

In the State of California the above is required by law (Section 4442 of the California Public Resources Code). Other states may have similar laws. Federal laws apply on federal lands. A spark arrester muffler is available at your nearest engine authorized service center.

Cut Along This Line

USE THIS SHEET AS A GUIDE TO DETERMINE SLOPES WHERE YOU MAY NOT OPERATE SAFELY.

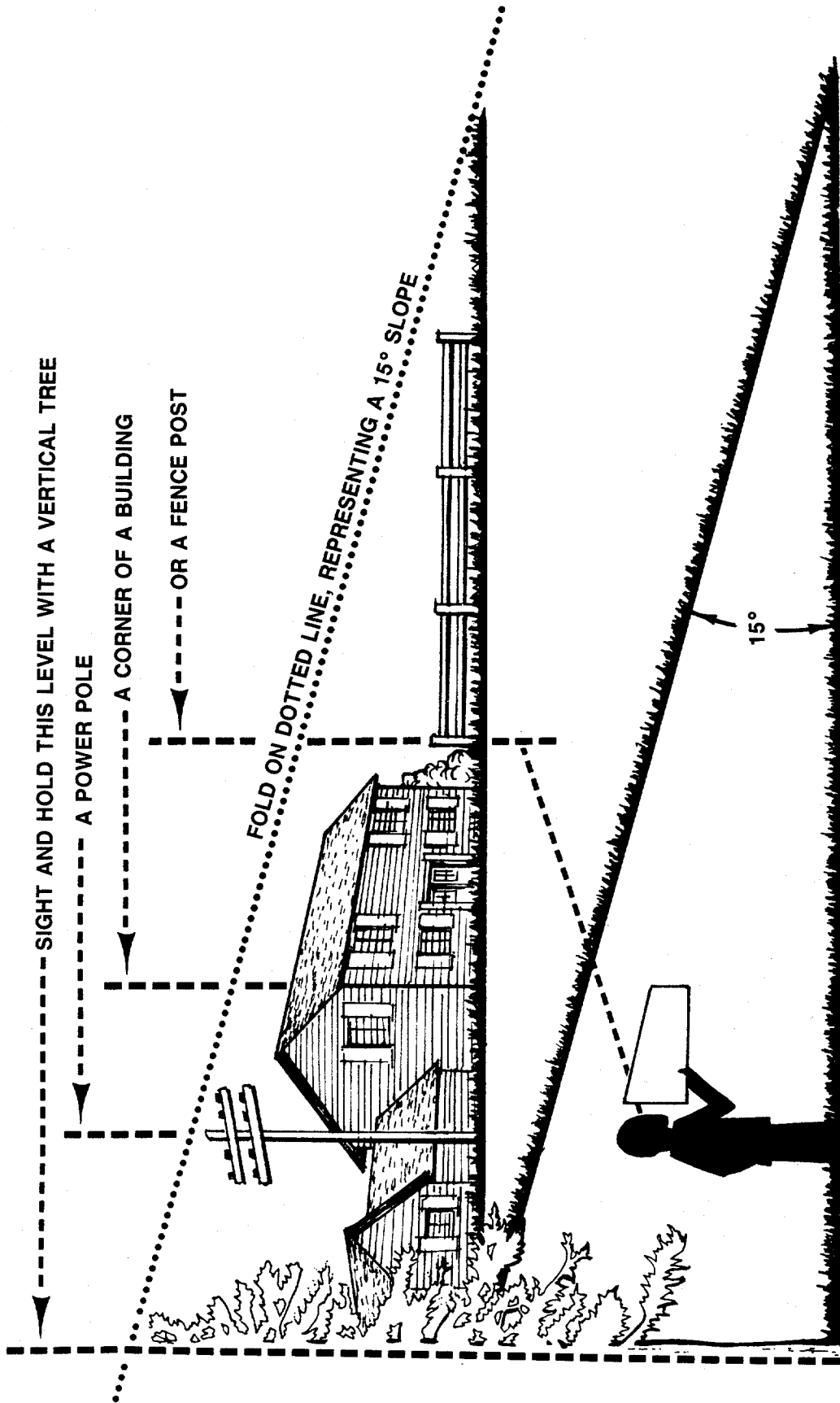

Do not mow on inclines with a slope in excess of 15 degrees (a rise of approximately 2½ feet every 10 feet). A riding mower could overturn and cause serious injury. If operating a walk-behind mower on such a slope, it is extremely difficult to maintain your footing and you could slip, resulting in serious injury.

Operate RIDING mowers up and down slopes, never across the face of slopes.
Operate WALK-BEHIND mowers across the face of slopes, never up and down slopes.

CONTENTS OF HARDWARE PACK

Remove this sheet from your owner's manual and lay the hardware on the illustration for identification purposes. After assembly, keep the Slope Gauge which is on the reverse side of this sheet for future use.
(Hardware pack may contain extra items which are not used on your unit.)

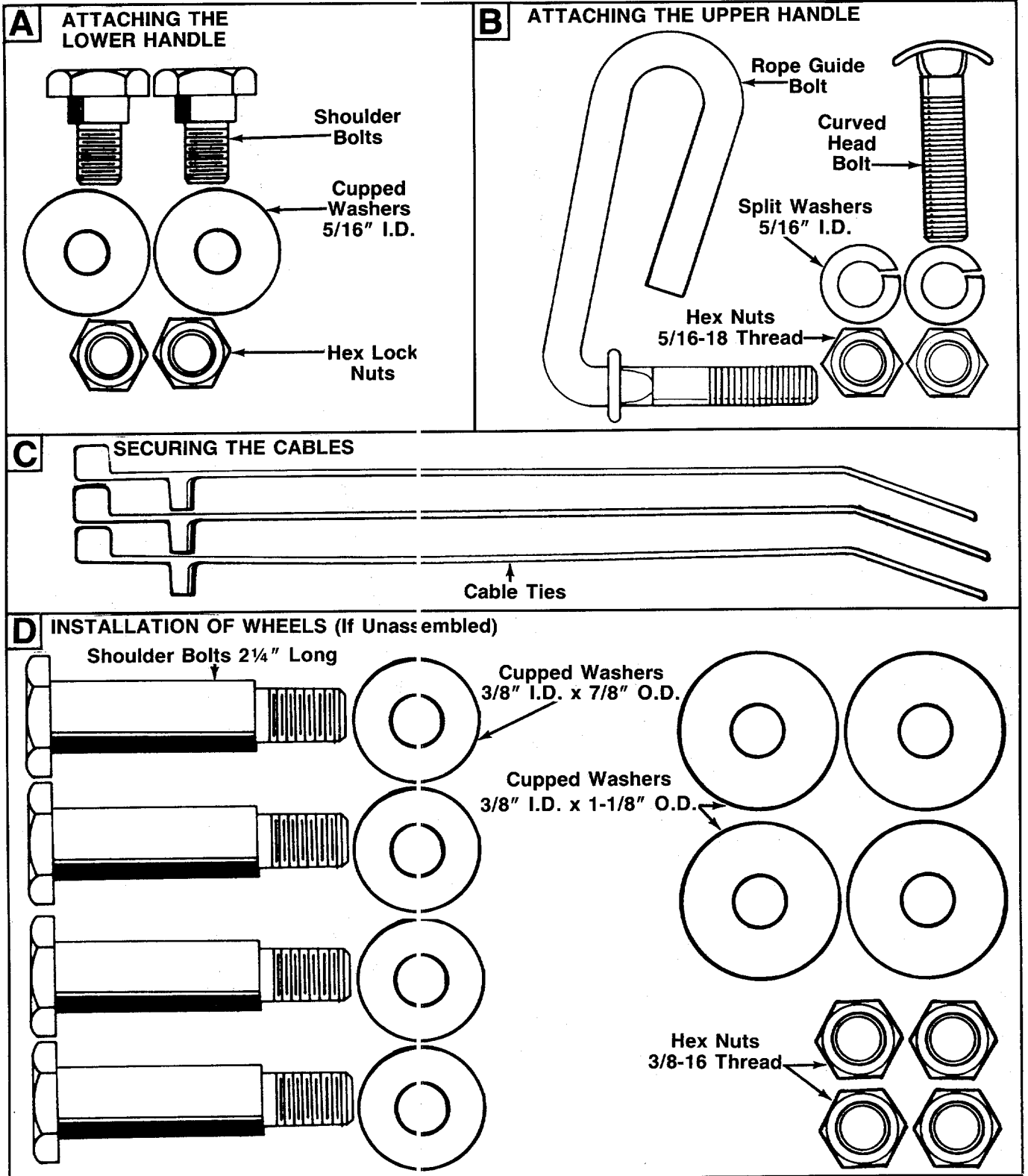

Cut A

This Line



IMPORTANT

RULES FOR SAFE OPERATION



THIS SYMBOL POINTS OUT IMPORTANT SAFETY INSTRUCTIONS WHICH, IF NOT FOLLOWED, COULD ENDANGER THE PERSONAL SAFETY AND/OR PROPERTY OF YOURSELF AND OTHERS. READ AND FOLLOW ALL INSTRUCTIONS IN THIS MANUAL BEFORE ATTEMPTING TO OPERATE YOUR LAWN MOWER. FAILURE TO COMPLY WITH THESE INSTRUCTIONS MAY RESULT IN PERSONAL INJURY. WHEN YOU SEE THIS SYMBOL—



HEED ITS WARNING.



DANGER

Your lawn mower was built to be operated according to the rules for safe operation in this manual. As with any type of power equipment, carelessness or error on the part of the operator can result in serious injury. If you violate any of these rules, you may cause serious injury to yourself or others.



TRAINING

1. Read this owner's manual carefully in its entirety before attempting to assemble or operate this machine. Be completely familiar with the controls and the proper use of this machine before operating it. Keep this manual in a safe place for future and regular reference and for ordering replacement parts.
2. Your rotary mower is a precision piece of power equipment, not a plaything. Therefore, exercise extreme caution at all times.
3. Never allow children to operate a power mower. Only persons well acquainted with these rules of safe operation should be allowed to use your mower.
4. Keep the area of operation clear of all persons, particularly small children and pets. Stop engine when they are in the vicinity of your mower to help prevent blade contact or thrown object injury. Although the area of operation should be completely cleared of foreign objects, an object may have been overlooked and could be accidentally thrown by the mower in any direction and cause serious personal injury to the operator or any others allowed in the area.



PREPARATION

1. Thoroughly inspect the area where the equipment is to be used. Remove all stones, sticks, wire, bones and other foreign objects which could be picked up and thrown by the mower in any direction and cause serious personal injury to the operator or any others allowed in the area.
2. Always wear safety glasses or eye shields during operation or while performing an adjustment or repair, to protect eyes from foreign objects that may be thrown from the machine in any direction.
3. Wear sturdy, rough-soled work shoes and close-fitting slacks and shirts to avoid entanglement in the moving parts. Never operate a unit in bare feet, sandals, or sneakers.
4. Check the fuel before starting the engine. Gasoline is an extremely flammable fuel. Do not fill the gasoline tank indoors, while the engine is running, or until engine has been allowed to cool for two minutes after running. Replace gasoline cap securely and wipe off any spilled gasoline before starting the engine as it may cause a fire or explosion.
5. Disengage the self-propelled mechanism or drive clutch on units so equipped before starting the engine.
6. The blade control handle is a safety device. Never attempt to bypass its operation. Doing so makes the safety device inoperative and may result in personal injury through contact with the rotating blade. The blade control handle must operate easily in both directions.
7. Never attempt to make a wheel or cutting height adjustment while the engine is running.
8. Never operate the equipment in wet grass. Always be sure of your footing. A slip and fall can cause serious personal injury. Keep a firm hold on the handle and walk, never run. Mow only in daylight or in good artificial light.



OPERATION

1. Do not change the engine governor settings or overspeed the engine. Excessive engine speeds are dangerous.
2. Do not put hands or feet near or under rotating parts. Keep clear of the discharge opening at all times as the rotating blade can cause injury.
3. Stop the blade when crossing gravel drives, walks or roads.
4. After striking a foreign object, stop the engine, remove the wire from the spark plug, and thoroughly inspect the mower for any damage. Repair the damage before restarting and operating the mower.
5. If the equipment should start to vibrate abnormally, stop the engine and check immediately for the cause. Vibration is generally a warning of trouble.
6. Shut the engine off and wait until the blade comes to a complete stop before removing the grass catcher or unclogging the chute. The cutting blade continues to rotate for a few seconds after the engine is shut off. Never place any part of the body in the blade area until you are sure the blade has stopped rotating.
7. Before cleaning, repairing or inspecting, make certain the blade and all moving parts have stopped. Disconnect the spark plug wire, and keep the wire away from the spark plug to prevent accidental starting.
8. Do not run the engine indoors.
9. Mow across the face of slopes, never up-and-down. Exercise extreme caution when changing direction on slopes. Do not mow excessively steep slopes. Always be sure of your footing. A slip and fall can cause serious personal injury.
10. Never operate mower without proper guards, plates or other safety protective devices in place.



MAINTENANCE AND STORAGE

1. Check the blade and engine mounting bolts at frequent intervals for proper tightness.
2. Keep all nuts, bolts, and screws tight to be sure the equipment is in safe working condition.
3. Never store the equipment with gasoline in the tank inside of a building where fumes may reach an open flame or spark. Allow the engine to cool before storing in any enclosure.
4. To reduce fire hazard, keep the engine free of grass, leaves, or excessive grease.
5. Check the grass catcher bag frequently for wear or deterioration. For safety protection, replace only with new bag meeting original equipment specifications.

➔ **IMPORTANT:** This unit is shipped **WITHOUT GASOLINE** or **OIL**. After assembly, service engine with gasoline and oil as instructed in the separate engine manual packed with your unit.

➔ **NOTE:** Reference to right or left hand side of the mower is observed from the operating position.

ASSEMBLY INSTRUCTIONS

The instructions in this manual cover various models of mowers. Follow only those instructions which pertain to your unit.

Tools Required for Assembly

- (1) 1/2" Wrench
- (1) 5/16" Wrench or Nutdriver
- (2) 9/16" Wrenches
- (Two 6" Adjustable Wrenches may be used instead of the above.)

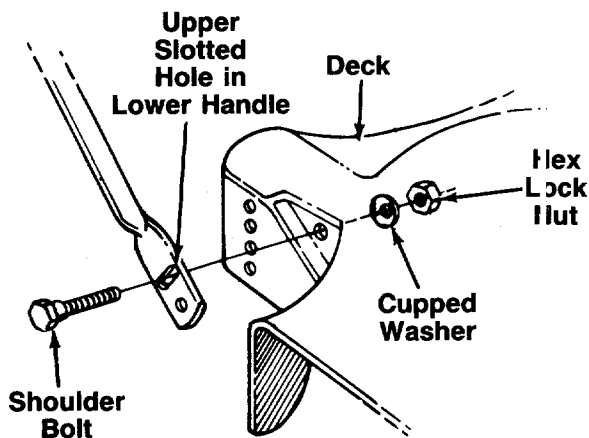

FIGURE 1.

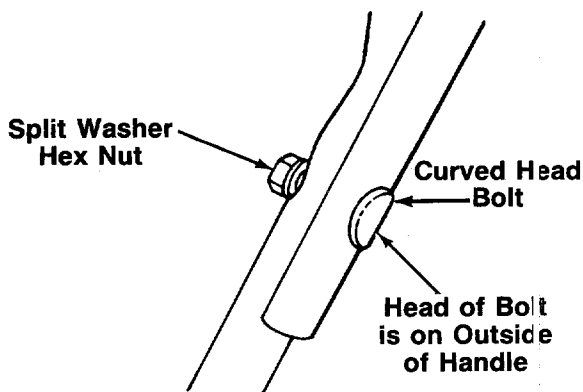

FIGURE 2.

UNPACKING

1. Remove the lawn mower from the carton by opening the top flaps and lifting the unit out. Be careful of the staples. Make certain all parts and literature have been removed from the carton before the carton is discarded.
2. Disconnect and ground the spark plug wire against the engine. Check beneath the deck for any cardboard packaging. Remove if present.
3. Stretch out all control cables and place on the floor. Be careful not to bend or kink the cables at any time during assembly.
4. Remove page four from this manual and lay the contents of the hardware pack on the illustration for identification.

ATTACHING THE LOWER HANDLE (Hardware A)

Attach the lower handle by lining up the upper slotted hole in lower handle with the mounting hole on deck and the hole in the rear baffle (on the inside of the deck). Make certain the instruction label on the lower handle can be read from the operating position. Place shoulder bolt through lower handle, deck and baffle. ← See figure 1. Place cupped washer on the shoulder bolt, with the cupped side of the washer against the baffle. Secure with hex lock nut.

➔ NOTE

It may be necessary to bend the ends of the lower handle inward slightly to obtain a tight fit against the deck.

ATTACHING THE UPPER HANDLE (Hardware B)

1. Place the upper handle in position over the lower handle. The throttle control lever must be facing up.

➔ NOTE

The right hand side of the handle will be secured with the rope guide bolt. However, left handed operators may assemble the rope guide bolt to the left side of the handle for easier starting by following steps 2 and 3 and reversing the left and right hand instructions.

- ← 2. Secure the left hand side of upper handle using the curved head bolt, split washer and hex nut as shown in figure 2.

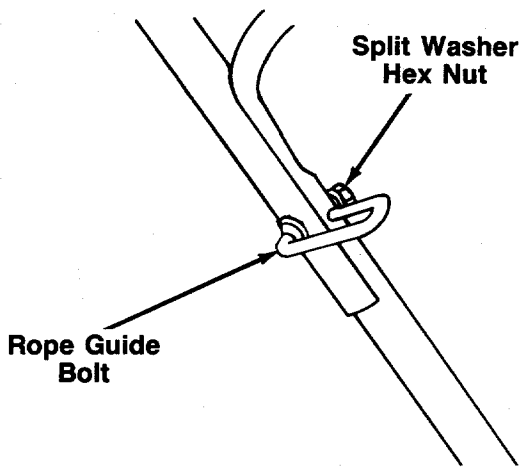

FIGURE 3.

3. Insert the rope guide bolt through the right hand side of upper and lower handle from the outside in. See figure 3. Secure with split washer and hex nut, finger tight only at this time.

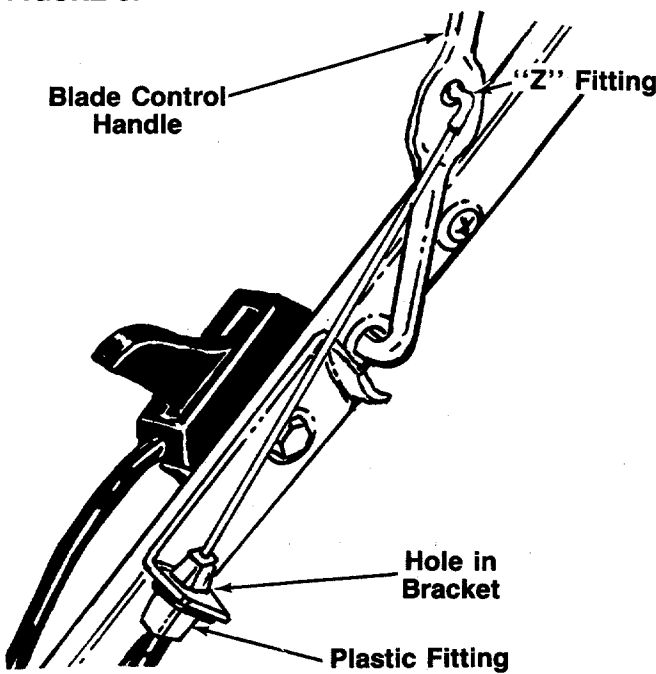

FIGURE 4.

ATTACHING THE BRAKE CABLE

1. The brake cable is attached to the engine, and has a "Z" fitting on the loose end. Route the brake cable below the lower handle. Place end of cable through the hole in the bracket as shown in figure 4.
4. Be careful not to bend or kink the cable at any time. Push the plastic fitting until it locks into the hole in the bracket.



WARNING

Brake cable must be assembled as shown for proper blade brake operation.

2. Hook the "Z" end of the brake cable into the hole in the blade control handle from the inside to the outside as shown in figure 4.

ATTACHING THE THROTTLE CABLE (Optional) Briggs and Stratton Engine

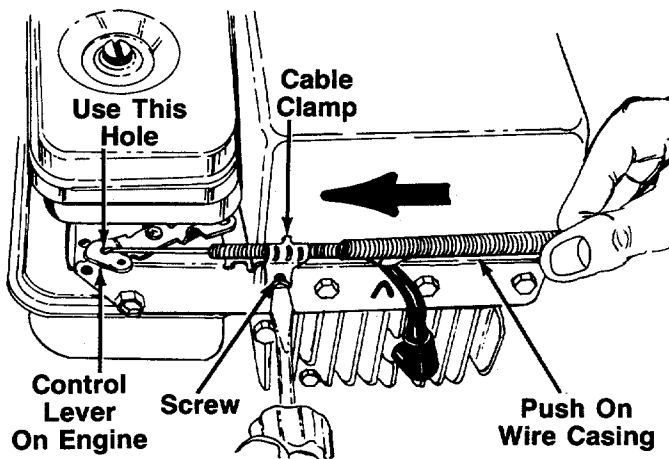

FIGURE 5.—Briggs and Stratton Engine

1. Place the throttle control lever on the handle in FAST position.
2. The throttle control cable is attached to the upper handle. Route the throttle control cable under the lower handle and inside the handle mounting bracket. Hook the "Z" end of the throttle control cable into the arm on the control lever on the engine which has two holes, using the outside hole as shown in figure 5.
3. Using a 5/16" wrench or nutdriver, remove the screw on the cable clamp shown in figure 5. Slip the control casing under the clamp. Replace the screw, but do not tighten (cable must still move freely beneath the clamp).
4. Place the throttle control lever on the engine in the full open position by pushing it toward outside of the unit. Push the wire casing on the throttle control cable toward the control lever on the engine as shown in figure 5 as you tighten the screw on the cable clamp.

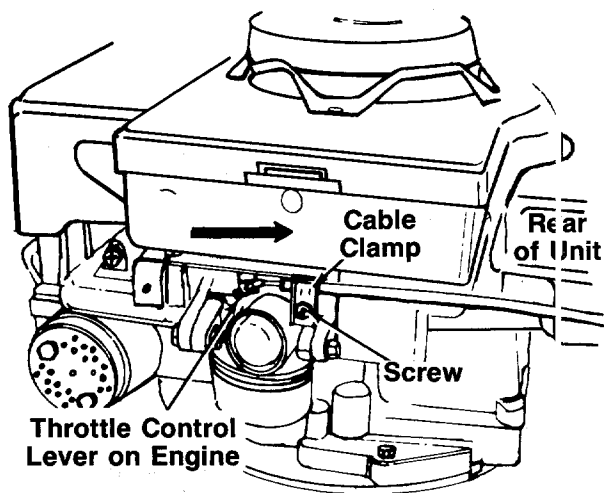

FIGURE 6.—Tecumseh Engine

ATTACHING THE THROTTLE CABLE (Optional) Tecumseh Engine

1. Place the throttle control lever on the handle in FAST position.
2. The throttle control cable is attached to the upper handle. Route the throttle control cable under the lower handle and inside the handle mounting bracket. Hook the "Z" end of the throttle control cable into the control lever on the engine as shown in figure 6.
3. Loosen (do not remove) the screw on the cable clamp shown in figure 6. Slip the control casing under the clamp (cable must move freely beneath the clamp).
4. Place the control lever on the engine in the full open position by pushing it as far toward the rear of the unit as it will go. Tighten the screw on the cable clamp to secure the cable in this position.

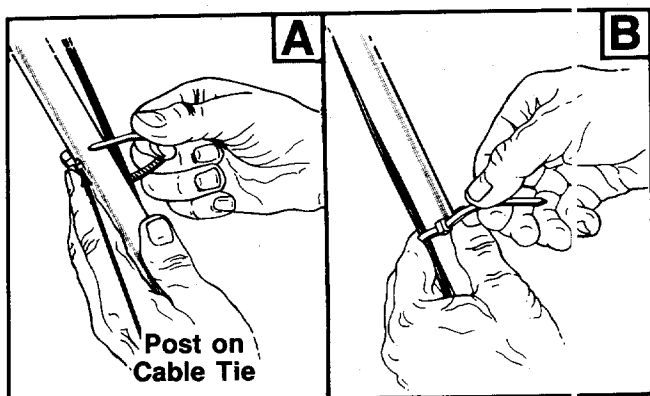

FIGURE 7.

SECURING THE CABLES (Hardware C)

Secure both cables to the right side of the handle as follows.

- A. Insert posts on cable ties into holes provided on the inside of the handle, one on the upper handle and two on the lower handle. See figure 7A.
- B. Secure the cables with the cable ties. See figure 7B.
- C. Trim excess ends of cable ties.

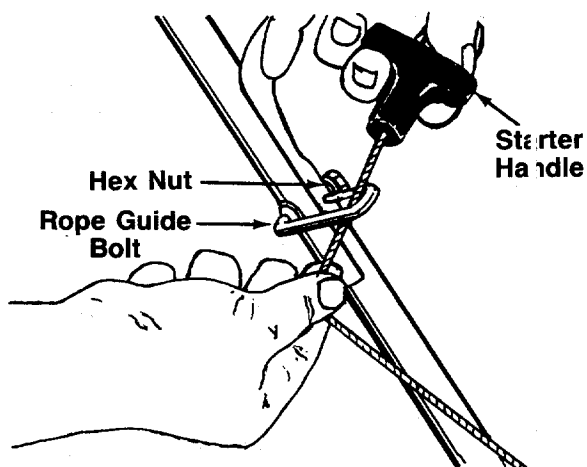

FIGURE 8.

ATTACHING THE STARTER ROPE

1. The starter rope is inside the top of the engine. Additional rope may be wound around the starter handle. If so, unwind the rope from the handle.
2. With the spark plug wire disconnected and grounded, depress the blade control handle and pull the rope out of the engine.
3. Slip the starter rope into the rope guide bolt as shown in figure 8.
4. Tighten the hex nut on the rope guide bolt securely.

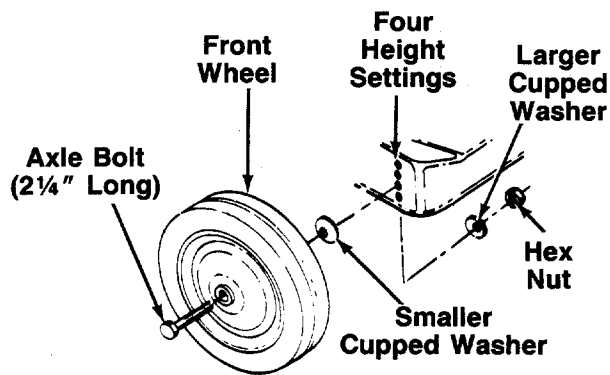

FIGURE 9.

INSTALLATION OF WHEELS (Hardware D)

If the wheels on your mower are not already assembled, proceed as follows.

The four holes provide four cutting heights for your mower. Use the same hole location for all four wheels when assembling. If wheels are to be assembled in the lowest cutting position (highest hole in the deck), refer to the note below.

← To assemble the wheels: (See figure 9)

1. Place axle bolt (2 1/4" long) through wheel.
2. Place one smaller cupped washer on axle bolt, with the cupped side of washer toward the deck (away from wheel).
3. Secure wheel to deck with one larger cupped washer on the inside of the deck (cupped side against the deck) and hex nut. Tighten securely.
4. Assemble the other wheels in the same manner.

➡ NOTE

If the lowest cutting position (highest hole in the deck) is used, it is necessary to place the larger washer on the outside of the deck and the smaller washer on the inside.

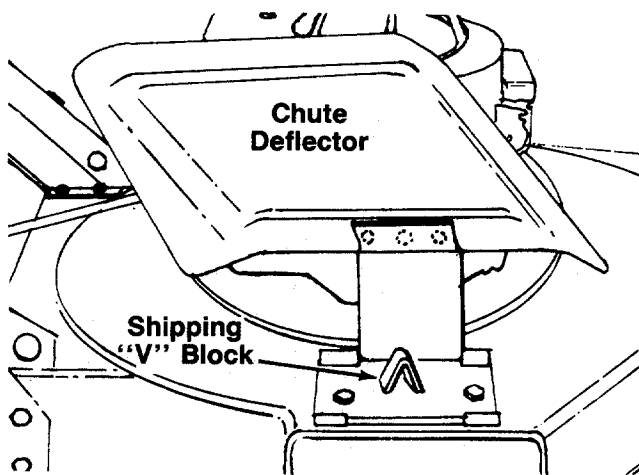

FIGURE 10.

FINAL ASSEMBLY OF MOWER

1. The chute deflector on your mower is held in an upright position by a "V" block for shipping purposes only. This "V" block must be removed and discarded before the mower is put into operation.

← See figure 10.

To remove the "V" block, pull the spring-loaded chute toward the engine. Remove the "V" block and carefully lower the chute into operating position, keeping fingers out of the way.

2. Make certain all nuts and bolts are tightened securely.

CONTROLS

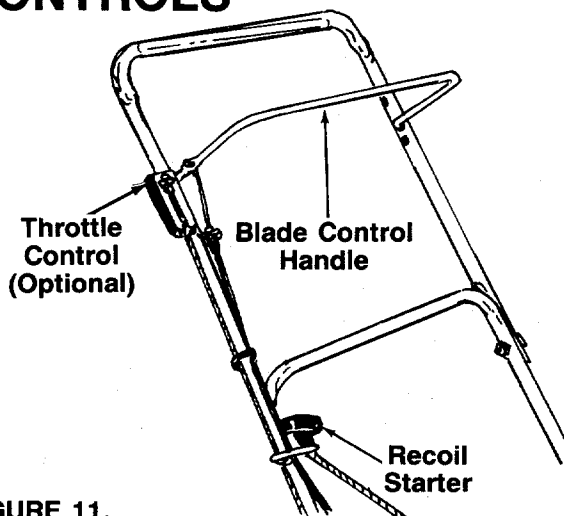

FIGURE 11.

BLADE CONTROL HANDLE

WARNING

THIS CONTROL MECHANISM IS A SAFETY DEVICE NEVER ATTEMPT TO BYPASS ITS OPERATIONS

The blade control handle is located on the upper handle of the mower. See figure 11. The blade control handle must be depressed in order to operate the unit. Release the blade control handle to stop the engine and blade.



The blade will be rotating whenever the engine is running.

THROTTLE CONTROL (Optional)

The throttle control is located on the right side of the upper handle. It is used to regulate the engine speed. The engine should be started with the engine in the FAST or START position.



The throttle control cannot be used to stop the engine.

RECOIL STARTER

The recoil starter handle is attached to the handle. See figure 11. Stand behind the unit in the operating position to start the unit.

OPERATION



FIGURE 12.

Keep hands and feet away from the chute area on cutting deck. See figure 12.

NOTE

If the wheels on your mower were assembled at the factory, they are set in a low cutting height position for shipping purposes. For best results, raise the cutting position until it is determined which height is best for your lawn. See cutting height adjustment section.

GAS AND OIL FILL-UP

Service the engine with gasoline and oil as instructed in the separate engine manual packed with your mower. Read instructions carefully.



Never fill fuel tank indoors, with engine running or until the engine has been allowed to cool for at least two minutes after running.

TO START ENGINE AND ENGAGE BLADE

1. Attach spark plug wire to spark plug.
2. Move the throttle control lever (optional) to FAST or START position.
3. **Tecumseh Engines Only:** Prime engine as instructed in the separate engine manual.
4. Standing behind the unit, depress the blade control handle and hold it against the upper handle as shown in figure 13.
5. Grasp the recoil starter handle as shown and pull back rapidly, extending rope fully. Return it slowly to the rope guide bolt.
6. After engine starts, move throttle control lever to desired engine speed if unit is so equipped.

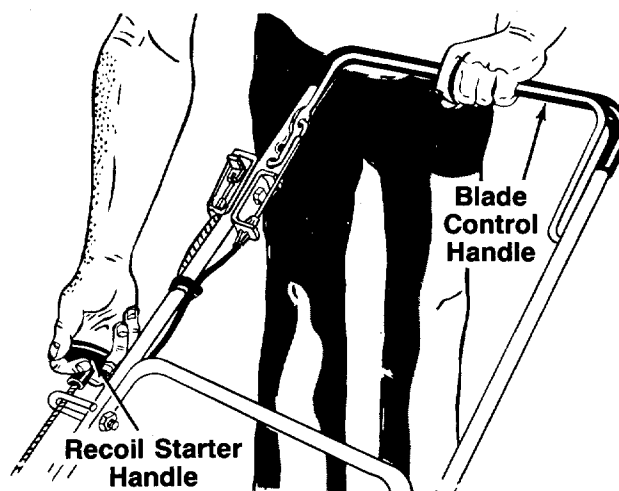

FIGURE 13.

NOTE

If any problems are encountered, refer to the Trouble Shooting Chart on page 16.

TO STOP ENGINE AND BLADE

1. Release the blade control handle to stop the engine and blade.



The blade continues to rotate for a few seconds after the engine is shut off.

2. Disconnect the spark plug wire and ground it against the engine to prevent accidental starting while equipment is unattended.

USING YOUR ROTARY MOWER

Be sure that lawn is clear of stones, sticks, wire, or other objects which could damage lawn mower or engine. Such objects could be accidentally thrown by the mower in any direction and cause serious personal injury to the operator and others.

Operate a new engine at intermediate speeds and light load for the first few hours as you would a new automotive engine.

For best results, do not cut wet grass because it tends to stick to the underside of the mower, preventing proper discharge of grass clippings, and could cause you to slip and fall. New grass or thick grass may require a narrower cut. Blade speed should be adjusted to the condition of the lawn.

The best mowing pattern is one that allows the clippings to discharge towards the uncut part of the lawn. This permits recutting of the clippings to further pulverize them. When cutting high weeds, discharge towards cut portion, then recut at right angles to first direction.

For best results, cut off one-third or less of the total length of the grass. Lawn should be cut in the fall as long as there is growth.

This mower is designed to be operated at full throttle to give you the best cut and do the most effective job of bagging the cut grass.

➡ IMPORTANT

If you strike a foreign object, stop the engine. Remove wire from spark plug, thoroughly inspect the mower for any damage, and repair the damage before restarting and operating the mower. Extensive vibration of the mower during operation is an indication of damage. The unit should be promptly inspected and repaired.

ADJUSTMENTS



Do not at any time make any adjustment to lawn mower without first stopping engine and disconnecting spark plug wire.

CUTTING HEIGHT ADJUSTMENT

Adjustment may be made by removing and moving axle bolts to desired position. Cutting heights will be raised as axle bolts are moved to a lower hole and lowered as axle bolts are moved to a higher hole in the deck. All axle bolts must be mounted in the same relative position. Belleville washers must be assembled so that the cupped side of the washers are against the deck. Refer to figure 9.

THROTTLE (Optional)

The throttle control wire assembly can be adjusted if necessary. Loosen the screw on the cable clamp shown in figure 5 or 6. Adjust as instructed in step 4 of "Attaching the Throttle Control Cable" in Assembly Instructions.

CARBURETOR ADJUSTMENTS



If any adjustments are made to the engine while the engine is running (e.g. carburetor), keep clear of all moving parts. Be careful of heated surfaces and muffler.

Minor carburetor adjustment may be required to compensate for differences in fuel, temperature, altitude and load. Refer to the separate engine manual packed with your mower for carburetor adjustment information.

➡ NOTE

A dirty air cleaner will cause an engine to run rough. Be certain air cleaner is clean and attached to the carburetor before adjusting carburetor. Refer to the separate engine manual.

LUBRICATION



Always stop engine and disconnect spark plug wire before cleaning, lubricating or doing any kind of work on lawn mower.

Blade Control—Lubricate the pivot points on the blade control handle and the brake cable at least once a season with light oil. See figure 14. The blade control must operate freely in both directions.

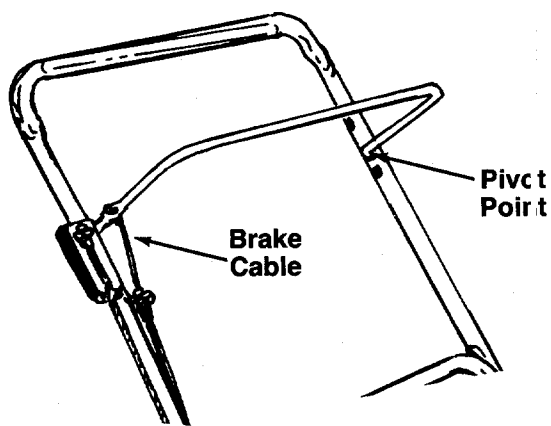

FIGURE 14.

Chute Deflector—The torsion spring and pivot point should be lubricated periodically with light oil to prevent any rust or binding. Deflector must work freely.

Wheels—The wheels require no lubrication. However, if the wheels are removed for any reason, lubricate the surface of the axle bolt and the inner surface of the wheel with light oil. A 4 oz. plastic bottle of light oil lubricant is available. Order part number 737-0170. Engine oil may also be used.

Engine—Follow engine manual for lubrication instructions.

Throttle (Optional)—Periodically lubricate throttle control lever and throttle wire assembly with a few drops of light oil for ease of operation.

MAINTENANCE

NOTE

When tipping the unit, empty the fuel tank and keep engine spark plug side up.

TROUBLE SHOOTING

Refer to page 16 of this manual for trouble shooting information.

CUTTING BLADE

A. Removal for Sharpening or Replacement



WARNING

Be sure to disconnect and ground the spark plug wire before working on the cutting blade to prevent accidental engine starting. Protect hands by using heavy gloves or a rag to grasp the cutting blade.

Remove the large bolt and lock washer which holds the blade and adapter to the engine crankshaft. Remove the blade and adapter from the crankshaft.

If the blade or blade adapter needs replacing, remove the two small bolts, lock washers and nuts which hold the blade to the adapter.



CAUTION

Periodically inspect the blade adapter for cracks, especially if you strike a foreign object. Replace when necessary

B. Sharpening

Remove the cutting blade by following the directions of the preceding section.

When sharpening the blade, follow the original angle of grind as a guide. It is **extremely important** that each cutting edge receives an equal amount of grinding to prevent an unbalanced blade. An unbalanced blade will cause excessive vibration when rotating at high speeds, may cause damage to the mower and could break, causing personal injury.

It is recommended that the blade always be removed from the adapter for the best test of balance. The blade can be tested by balancing it on a round shaft screwdriver. Remove metal from the heavy side until it balances evenly.

C. Reassembly

Before reassembling the blade and the blade adapter to the unit, lubricate the engine crankshaft and the inner surface of the blade adapter with light oil. Lubricating the bolt holes, bolts and inner surface of the nuts with light oil is also recommended. A 4 oz. plastic bottle of light oil lubricant is available. Order part number 737-0170. Engine oil may also be used.

When replacing the blade, be sure to install the blade with the side of the blade marked "Bottom" (or with part number) facing the ground when the mower is in the operating position.

Blade Mounting Torque

3/8" Dia. Bolt 375 in. lb. min., 450 in. lb. max.

5/16" Dia. Bolt 150 in. lb. min., 250 in. lb. max.

To insure safe operation of your unit, all nuts and bolts must be checked periodically for correct tightness.

DECK

The underside of mower deck should be cleaned after each period of use as grass clippings, leaves, dirt and other matter will accumulate. This accumulation of grass clippings, etc., is undesirable as it will invite rust and corrosion and may cause an uneven discharge of grass clippings at the next cutting.

The deck may be cleaned by tilting the mower forward or on its side and scraping clean with a suitable tool or by washing with a stream of water from a garden hose.

 **NOTE**

Do not direct the stream of water at a hot engine as damage to the engine may result.

ENGINE

Refer to the separate engine manual for engine maintenance instructions.

Maintain **engine oil** as instructed in the separate engine manual packed with your unit. Read and follow instructions carefully.

Service **air cleaner** every 25 hours under normal conditions. Clean every few hours under extremely dusty conditions. Poor engine performance and flooding usually indicates that the air cleaner should be serviced. To service the air cleaner, refer to the separate engine manual packed with your unit.

The **spark plug** should be cleaned and the gap reset once a season. Spark plug replacement is recommended at the start of each mowing season; check

engine manual for correct plug type and gap specifications.

OFF-SEASON STORAGE

The following steps should be taken to prepare lawn mower for storage.

1. Clean and lubricate mower thoroughly as described in the lubrication instructions.
2. Refer to engine manual for correct engine storage instructions.
3. Coat mower's cutting blade with chassis grease to prevent rusting.
4. Store mower in a dry, clean area.

 **NOTE**

When storing any type of power equipment in an unventilated or metal storage shed, care should be taken to rust-proof the equipment. Using a light oil or silicone, coat the equipment, especially cables and all moving parts.

 **NOTE**

The use of any accessory on this Rotary Mower other than those manufactured by the mower manufacturer is **not** recommended.

GRASS CATCHER, Model 065, is available as optional equipment for the mowers shown in this manual.



1. DO NOT operate the mower without the entire grass catcher or chute deflector in place.
2. DO NOT operate the mower without the protective shield on the rear of the deck in place.

 **NOTE**

Under normal usage bag material is subject to wear and should be checked periodically. Be sure any replacement bag complies with the mower manufacturer's recommendations.

For replacement bags, use only factory authorized replacement bag Part Number 764-0217.

Model 020

NOTE

This instruction manual covers various models and all specifications shown do not necessarily apply to your model. Specifications subject to change without notice or obligation.

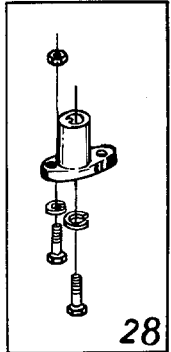
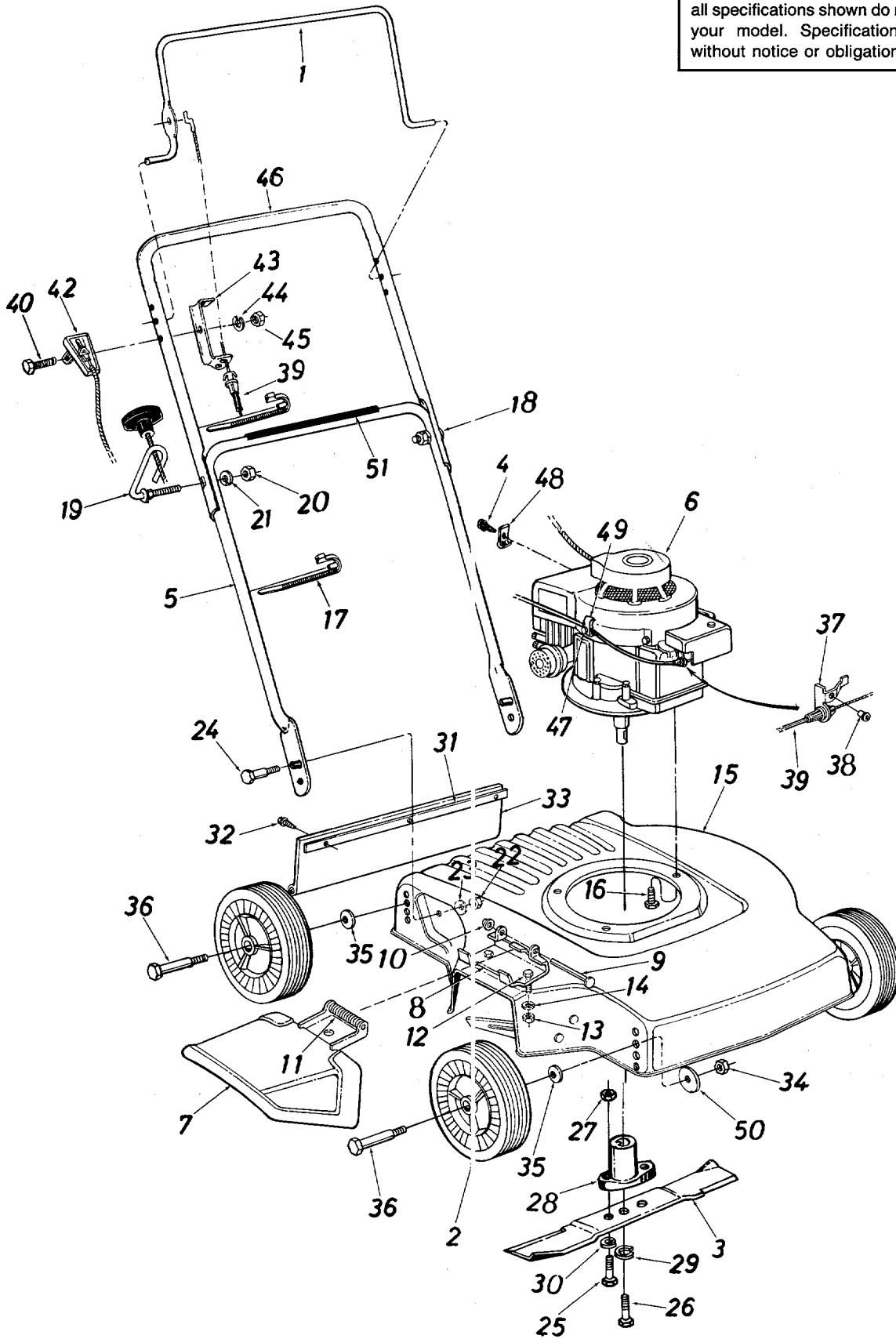

Model 020

PARTS LIST FOR 020 ROTARY MOWER

EF. O.	PART NO.	COLOR CODE	DESCRIPTION	NEW PART	REF. NO.	PART NO.	COLOR CODE	DESCRIPTION	NEW PART
1	747-0500		Control Handle—R.H.		27	712-0123		Hex Nut 5/16-24 Thd.*	
2	**		Plastic Wheel Ass'y. 6 x 1.50		28	753-0348		Blade Adapter Kit	
3	742-0121		18" Blade		29	736-0217		L-Wash. 3/8" I.D.—H.D.	
4	710-0227		Hex Wash. Hd. AB-Tap Scr. #8 x .50" Lg.†		30	736-0119		L-Wash. 5/16" I.D.*	
5	749-0373		Lower Handle (Chrome)		31	14835		Retaining Strip	
	749-0372		Lower Handle (Painted)		32	710-0776		Hex Wash. Hd. AB-Tap Scr. 1/4" x .62" Lg.	
6	—		Engine		33	731-0583		Rear Flap Ass'y.	
7	11681	463	Chute Deflector Ass'y.— Comp.		34	712-0798		Hex Nut 3/8-16 Thd.*	
					35	736-0105		Bell-Wash. .400" I.D. x .88" O.D.	
8	11130		Adapter Plate						
9	711-0555		Pivot Pin		36	738-0213		Shld. Bolt .498" Dia. x 1.450" Lg.	
10	726-0106		Push Nut 1/4" Rod						
11	732-0253		Torsion Spring		37	14924		Cable Bracket	
12	710-0289		Hex Bolt 1/4-20 x .50" Lg.*		38	728-0171		Pop Rivet .156" Dia. x .379	
13	712-0287		Hex Nut 1/4-20 Thd.*		39	746-0551		Control Cable—43" (B&S Eng.)†	
14	736-0329		L-Wash. 1/4" I.D.*					Control Cable—39" (Tec. Eng.)†	
15	14922	463	18" Deck Ass'y.			746-0476			
16	710-0654		Hex Wash. Hd. TT-Tap Scr. 3/8-16 x 1.00" Lg.		40	710-0559		Hex Bolt 1/4-28 x 1.75" Lg.	
17	726-0240		Cable Tie	N	42	746-0644		Throttle Control Ass'y. Comp.	
18	710-0671		Curved Carriage Bolt 5/16-18 x 1.38" Lg.		43	16201		Cable Mounting Brkt.	
					44	736-0175		L-Wash. 1/4" I.D.	
19	710-0842		Rope Guide Bolt		45	712-0138		Hex Nut 1/4-28 Thd.	
20	712-0267		Hex Nut 5/16-18 Thd.*		46	749-0536		Upper Handle (Chrome)	
21	736-0119		L-Wash. 5/16" I.D.*			749-0538		Upper Handle (Painted)	
22	712-0429		Hex Ins. L-Nut 5/16-18 Thd.		47	710-0429		Hex B-Tap Scr. #10 x .38" Lg.†	
23	736-0242		Bell-Wash. .345" I.D. x .88" O.D.		48	751-0369		Casing Clamp†	
					49	12894		Casing Clamp†	
24	738-0140		Shoulder Bolt .437" Dia. x .180		50	736-0331		FI-Wash. .398" I.D. x 1.13"	
25	710-0888		Hex Bolt 5/16-24 x 1.00" Lg. (Grade 5) Special		51	777-5776		Instruction Label—Handle	
26	710-0331		Hex Bolt 3/8-24 x 2.25" Lg. (Grade 5)		—	8020-000-7		Hardware Pack	

†Optional Parts

*For faster service obtain standard nuts, bolts, and washers locally. If these items cannot be obtained locally, order by part number and size as shown on parts list.

If color or finish is important when ordering parts, use the appropriate color code shown below (i.e. (part no.)—463 for Topflite Red Finish).

NOTE: The engine is not under warranty by the mower manufacturer . . . If repairs or service is needed on the engine, please contact your nearest authorized engine service outlet. Check the "Yellow Pages" of your telephone book under "Engines—Gasoline."



Color Codes

312—White
436—Radiant Yellow
447—Patina Silver
452—Black
456—Radiant Tangerine
460—Green Flake

463—Topflite Red
480—Brilliant Green
483—Charcoal Grey
499—Beige
606—Majestic Orange
629—Silver Flake

**Wheel Assembly

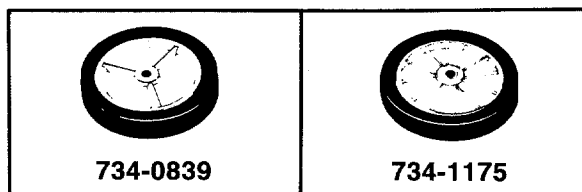

Trouble Shooting Chart

Symptom	Possible Causes	Corrective Action
1 Engine fails to start	<p>A Blade control handle disengaged B Check fuel tank for gas C Spark plug lead wire disconnected D Throttle control lever not in the starting position E Faulty spark plug F Carburetor improperly adjusted, engine flooded</p> <p>G Old stale gasoline H Engine brake engaged</p>	<p>A Engage blade control handle. B Fill tank if empty. C Connect lead wire. D Move throttle lever to start position.</p> <p>E Clean, adjust gap or replace.† F Remove spark plug, dry the plug, crank engine with plug removed, and throttle in off position. Replace spark plug and lead wire and resume starting procedures. G Drain and refill with fresh gasoline. H Follow starting procedure.</p>
2 Hard starting or loss of power	<p>A Spark plug wire loose B Carburetor improperly adjusted C Dirty air cleaner</p>	<p>A Connect and tighten spark plug wire. B Adjust carburetor.† C Clean air cleaner.†</p>
3 Operation erratic	<p>A Dirt in gas tank B Dirty air cleaner C Water in fuel supply D Vent in gas cap plugged E Carburetor improperly adjusted</p>	<p>A Remove the dirt and fill tank with fresh gas. B Clean air cleaner.† C Drain contaminated fuel and fill tank with fresh gas. D Clear vent or replace gas cap. E Adjust carburetor.†</p>
4 Occasional skip (hesitates) at high speed	<p>A Carburetor idle speed too slow B Spark plug gap too close C Carburetor idle mixture adjustment improperly set</p>	<p>A Adjust carburetor.† B Adjust to .030". C Adjust carburetor.†</p>
5 Idles poorly	<p>A Spark plug fouled, faulty, or gap too wide B Carburetor improperly adjusted C Dirty air cleaner</p>	<p>A Reset gap to .030" or replace spark plug. B Adjust carburetor.† C Clean air cleaner.†</p>
6 Engine overheats	<p>A Carburetor not adjusted properly B Air flow restricted C Engine oil level low</p>	<p>A Adjust carburetor.† B Remove blower housing and clean.† C Fill crankcase with the proper oil.</p>
7 Excessive vibration	<p>A Cutting blade loose or unbalanced B Bent cutting blade</p>	<p>A Tighten blade and adapter. Balance blade. B Replace blade.</p>

†Refer to separate engine manual packed with your unit.

Note: For repairs beyond the minor adjustments listed above, contact your local authorized service dealer.

PARTS INFORMATION

POWER EQUIPMENT PARTS AND SERVICE

Parts and service are available through the authorized service firms listed below. All orders should specify the model number of your unit, part numbers, description of parts and the quantity of each part required.

NOTE: If any parts are found to be missing or defective upon assembly of this unit, write to advise the factory so that immediate replacement can be made.

ALABAMA	BIRMINGHAM
Auto Electric & Carburetor Co.	2625 4th Ave. S. 3E233
ARKANSAS	NORTH LITTLE ROCK
Sutton's Lawn Mower Shop	5301 Roundtop Drive Box 368, Rt. 4 7E117
CALIFORNIA	PORTERVILLE
Billious	75 North D Street 9E257
COLORADO	DENVER
Spitzer Industrial Products Co.	6601 N. Washington St. 8C229
FLORIDA	JACKSONVILLE
Radco Distributors	4909 Victor St. Box 5459 3E207
	HIALEAH
Small Eng. Dist.	7995 W. 26th Court 3E016
GEORGIA	EAST POINT
East Point Cycle & Key Inc.	2834 Church St. 3C344
ILLINOIS	LYONS
Keen Edge Co.	8615 Ogden Ave. 6C534
INDIANA	ELKHART
Parts & Sales Inc.	2101 Industrial Pkwy. 4E516
IOWA	DUBUQUE
Power Lawn & Garden Equip.	2551 J.F. Kennedy 5E001
LOUISIANA	NEW ORLEANS
Suhren Engine Co.	8330 Earhart Blvd. 7C118
MARYLAND	TAKOMA PARK
Center Supply Co.	6867 New Hampshire Ave. 2C912
MASSACHUSETTS	SPRINGFIELD
Morton B. Collins Co.	300 Birnie Ave. 01107
MICHIGAN	LANSING
Lorenz Service Co.	2500 S. Pennsylvania 4E910
	MOUNT CLEMENS
Power Equipment Dist.	340 Hubbard 4E043
MINNESOTA	HOPKINS
Hance Distributing Inc.	420 Excelsior Ave. W. 5E343
MISSOURI	EARTH CITY
Oscar Wilson Engine & Parts	4159 Shoreline Dr. 6C045
	KANSAS CITY
Automotive Equip. Service	3117 Holmes St. 6A109
	ST. JOSEPH
Ross-Frazier Supply Co.	8th and Monterey 6A503
	ST. LOUIS
Henzler, Inc.	2015 Lemay Ferry Rd. 6A125
NEW JERSEY	ALLOWAY
Piersons	Canal St. 0A001
NEW MEXICO	ALBUQUERQUE
Spitzer Eng. & Parts Co.	1023 Third Ave. N.W. 8A103

BRIGGS AND STRATTON, TECUMSEH AND PEERLESS PARTS AND SERVICE

Briggs & Stratton, Tecumseh and Peerless parts and service should be handled by your nearest authorized engine service firm. Check the yellow pages of your telephone directory under the listing **Engines—Gasoline**, Briggs & Stratton or Tecumseh Lauson.

NEW YORK	CARTHAGE
Gamble Dist., Inc.	West End Ave. 13619
NORTH CAROLINA	WESTBORO
Dixie Sales Company	335 N. Green 27402
OHIO	CARROLL
Stebe's Mid-State Mower Supply	Box 366, 71 High St. 43112
	CLEVELAND
Bleckrie, Inc.	7900 Lorain Ave. 44102
	WADSWORTH
National Central	687 Seville Rd. 44281
Burton Supply Co.	YOUNGSTOWN
	1301 Logan Ave. Box 929 44501
OREGON	PORTLAND
Kenton Supply Co.	8216 N. Denver Ave. 97217
PENNSYLVANIA	HARRISBURG
EECO Inc.	4021 N. 6th St. 17110
	WILLOW GROVE
Thompson Rubber Co.	850 Davisville Rd. 19090
Bluemont Co.	PITTSBURGH
	11125 Frankstown Rd. 15235
Frank Roberts & Sons	PUNXSUTAWNEY
	R.D. 2 15767
Scranton Auto Ignition Co.	SCRANTON
	1133-35 Wyoming Ave. 18509
TENNESSEE	KNOXVILLE
Ace Distributors	2103 Magnolia 3791
	MEMPHIS
American Sales & Service, Inc.	3035-43 Bellbrook 38116
TEXAS	DALLAS
Marr Brothers, Inc.	423 E. Jefferson 75203
	FORT WORTH
Woodson Sales Corp.	6733 Baker Blvd. Hwy. 10 76118
Bullard Supply Co.	HOUSTON
	2409 Commerce St. 77003
Engine House Inc.	SAN ANTONIO
	8610 Botts Lane P.O. Box 17867 78217
UTAH	SALT LAKE CITY
Powered Products	1661 N. Beck St. 84116
VIRGINIA	ASHLAND
RBI Corp.	101 Cedar Ridge Dr. 23005
WASHINGTON	SEATTLE
Equip. Northwest	1410 14th Ave. 98122
WISCONSIN	MILWAUKEE
Wisconsin Magneto Inc.	4727 N. Teutonia St. 53209

WARRANTY PARTS AND SERVICE POLICY

(0686)

The purpose of warranty is to protect the customer from defects in workmanship and materials, defects which are NOT detected at the time of manufacture. It does not provide for the unlimited and unrestricted replacement of parts. Use and maintenance are the responsibility of the customer. The manufacturer cannot assume responsibility for conditions over which it has not control. Simply put, if it's the manufacturer's fault, it's the manufacturer's responsibility; if it's the customer's fault, it's the customer's responsibility.

CLAIMS AGAINST THE MANUFACTURER'S WARRANTY INCLUDES:

1. Replacement of Missing Parts on new equipment.
2. Replacement of Defective Parts within the warranty period.
3. Repair of Defects within the warranty period.

All claims MUST be substantiated with the following information:

1. Model Number, Serial Number and/or Data Code of unit involved.
2. Date unit was purchased or first put into service.
3. Date of Failure.
4. Nature of Failure.