

# Owner's Operating Service Instruction Manual

Model No.  
116-530A

- ASSEMBLY
- OPERATION
- REPAIR PARTS

**22" HI WHEEL ROTARY MOWER**



## **CAUTION**

Please note that the chute deflector on your mower is in an upright position. It is held in that position by a shipping block. This block is used for shipping purposes only. It must be removed and discarded before your mower is put into operation.

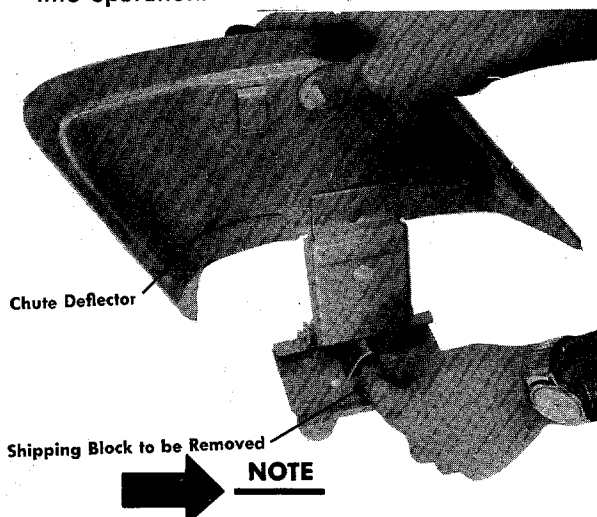

For shipping purposes your mower is set with the wheels in a low cutting height position. For best results raise the cutting position until it is determined which height is best for your lawn. See adjustments.

## **OPERATION**

1. Before starting engine, check LUBRICATION INSTRUCTIONS.
2. Check lockout control handles for proper operation. If too great a pressure is needed to operate these controls, damage can be done to both the mechanism and the rods. Readjust so only slight pressure is needed to operate both the blade engaging control and the self-propelled lockout control. See ASSEMBLY INSTRUCTIONS Step 9.
3. Service engine with gasoline and oil. See engine instructions for complete care and maintenance of engine. READ DIRECTIONS CAREFULLY.
4. Be sure engine crankcase is filled to capacity with proper grade of oil.
5. Move both control handles to "OFF" position.
6. Move throttle control lever to "CHOKE" position.
7. Crank engine. Move throttle control lever to "FAST" position as soon as engine fires. Use choke as needed to keep engine running during warm up period.
8. Put blade into motion by moving blade control handle to "ON" position.  
To engage the blade with the engine running . . .
  - a. Move the throttle control lever to "FAST" position.
  - b. Engage the blade engagement handle SLOWLY.
  - c. Adjust engine speed.
9. A brief break-in period is essential to insure maximum engine and mower life. This consists of running the engine at half speed for a period of time required to use one tank of gasoline. It is also recommended to change crankcase oil after the first five hours of operation or as operating conditions dictate. Always check oil before operating the mower. **BE SURE CRANKCASE IS FULL.**
10. Proper lubrication must be maintained at all times.
11. Appropriate clothing should be worn when cutting brush or heavy weeds. Safety shoes and safety glasses are highly recommended.
12. The engine is stopped by moving the throttle control lever to "STOP" position.

## **ADJUSTMENT**

1. Handles may be adjusted by changing the position of the lower support mounting holes. When this change is made, it may also be necessary to check the adjustment of control rod. See Step 9 in ASSEMBLY INSTRUCTIONS
2. Control rod adjustments are made as shown in ASSEMBLY INSTRUCTIONS Steps 9 and 12.
3. Cutting height adjustment is made by removing and moving axle bolts to the desired positions. All axle bolts must be mounted in the same relative position to the deck. When wheels are mounted to the deck, **the crown shape washers must be assembled with the crown away from the deck.** This is necessary to prevent the axle bolts from loosening.
4. If throttle adjustment becomes necessary, the throttle control wire may be reset as follows:
  - a. Loosen, but do not remove, screw securing throttle control wire assembly at engine.
  - b. Move throttle control lever on handle to "CHOKE" position.
  - c. Move lever to which control wire is fastened to engine to full choke position. Retighten screw to secure throttle control wire assembly.

## LUBRICATION



### IMPORTANT

Always stop engine and disconnect spark plug wire before cleaning, lubricating or doing any kind of work on lawn mower.

1. **Wheels**—Front wheel bearings are of self-lubricating Fortiflex. They require no lubrication. Rear wheels of Lifetime graphoil bearings require little lubrication. A light film of oil applied to these bearings will reduce normal friction.
2. **Throttle**—Periodically lubricate throttle control lever and entire length of throttle wire assembly with a few drops of SAE 30 engine oil for ease of operation.
3. **Engine**—Follow engine manual for lubrication instructions. Check oil level before each mowing.
4. **Friction point** between idler bracket assembly (Ref. No. 18 on page 10) and deck should be greased once each season with a multi-purpose grease.
5. **Blade Spindle Assembly**—The Blade Spindle Assembly is equipped with a grease fitting. Use grass discharge chute for access to the fitting located under the deck. Use multi-purpose grease. Lubricate PRIOR to initial use and every 25 hours thereafter. **Caution:** Be sure spark plug wire is disconnected and grounded.

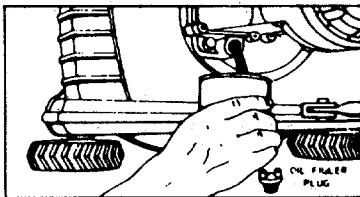

### NOTE

FILL AND DRAIN OIL FROM OIL FILL PLUG.

Always disconnect spark plug cable during repairs, refueling or changing oil. Engine oil may be drained through oil filler opening by tilting the mower on its side. Change oil after first 5 hours of operation while engine is warm. Thereafter, change oil every 25 hours of operation while engine is warm.

6. **Protective Shield**—The pivot points on the protective shield should be lubricated periodically with oil to prevent any rust or binding up.
7. **Chute Deflector**—The torsion spring and pivot point should be lubricated periodically with oil to prevent any rust or binding up. Deflector must work freely.

## MAINTENANCE



### IMPORTANT

Always stop engine and disconnect spark plug wire before cleaning, lubricating or doing any kind of work on lawn mower.

1. **Cutting Blade**—Remove all nuts and bolts holding the blade to the blade hub.

When sharpening blade, follow the original angle of grind as a guide. It is extremely important that each cutting edge receives an equal amount of grinding to prevent an unbalanced blade. An unbalanced blade will cause excessive vibration when rotating at high speeds and may cause damage to the mower. Upon reassembling, make certain all parts are assembled properly and tightened securely.

2. **Deck**—The underside of mower deck should be cleaned after each period of use as grass clippings, leaves, dirt and other matter accumulates. This accumulation of grass clippings, etc. is undesirable as it will invite rust and corrosion and may cause an uneven discharge of grass clippings at next cutting.

The deck may be cleaned by tilting the mower backward or on its side and scraping clean with a suitable tool or by washing with a stream of water from a garden hose. **Caution:** Do not direct the stream of water at a hot engine as damage to the engine may result.

3. **Belt replacement** may be made as follows:
  - a. Remove blade spindle cover.
  - b. Remove front belt guard.
  - c. Remove blade tension spring.
  - d. Loosen belt on bracket of idler bearing assembly.
  - e. Remove bracket lever assembly.
  - f. Remove damaged or worn belt.
  - g. Place new belt on engine pulley. Do not bend belt guard pins. Belt should be inside of pins.
  - h. Work belt to front and mount on blade spindle pulley. Replace front belt guard.
  - i. Replace brake lever assembly.
  - j. Slip belt on idler pulley between pulley and belt bracket.
  - k. Replace blade tension spring.
  - l. Move blade lockout handle to "ON" position.
  - m. Position belt bracket on idler pulley to clear the tightened belt. Secure belt bracket in position. See drawing on page 2.
  - n. Replace blade spindle cover.



To insure safe operation of your unit,  
ALL nuts and bolts must be checked  
periodically for correct tightness.

4. Storage—The following steps should be taken to prepare the lawn mower for storage:
- Clean and lubricate mower thoroughly as described in the preceding instructions.
  - Refer to engine manual for correct engine storage instructions.
  - Coat mower's cutting blade with multi-purpose grease to prevent rusting.
  - Place blocks under deck to raise tires clear of floor.

### USING YOUR ROTARY MOWER

For best results do not cut wet grass because it tends to stick to the underside of the mower, thus preventing proper discharge of grass clippings. If wet grass must be cut, reduce walking speed to help distribute the clippings more effectively.

New grass should be treated as wet grass, otherwise a normal walking speed is about the right pace for efficient mowing.

The best mowing pattern is one that allows the clippings to discharge towards the uncut part of the lawn. This permits recutting of the clippings to further pulverize them. When cutting high weeds, discharge towards cut portion then recut at right angle to first direction.

Lawns should be cut in fall as long as there is growth.

---

### **BLADE IDLER BRACKET ASSEMBLY DETAIL**

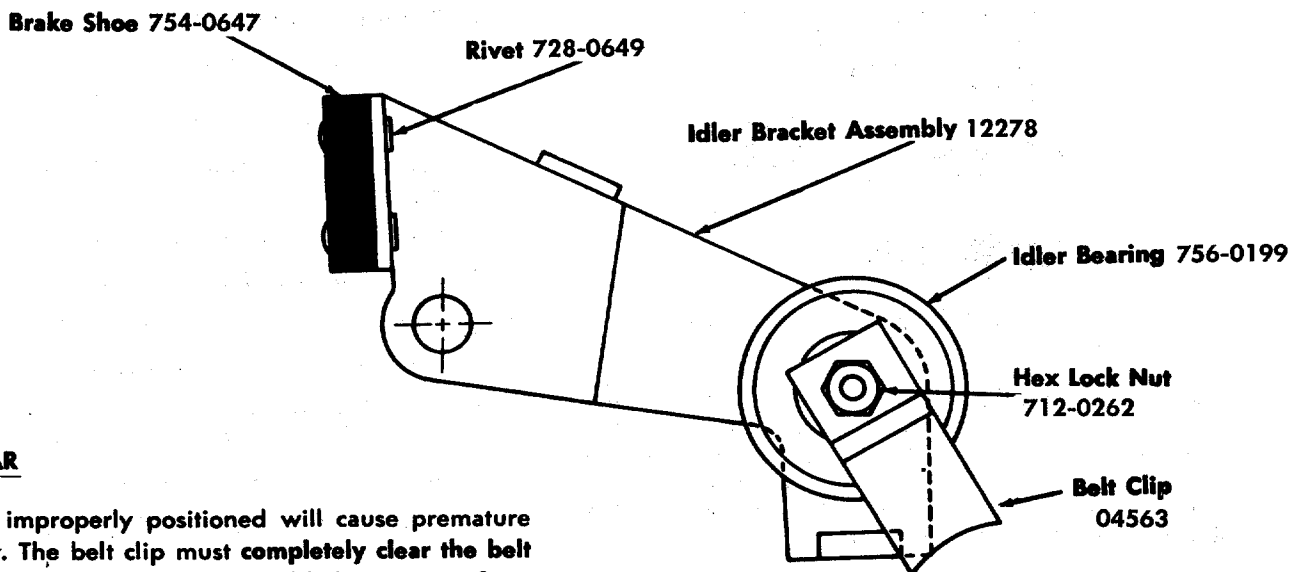

### **BELT WEAR**

Belt clips improperly positioned will cause premature belt wear. The belt clip must completely clear the belt when the belt is tightened. It should also assist in freeing the belt from the blade spindle pulley when the belt is loose. This may be checked by removing the blade spindle cover.

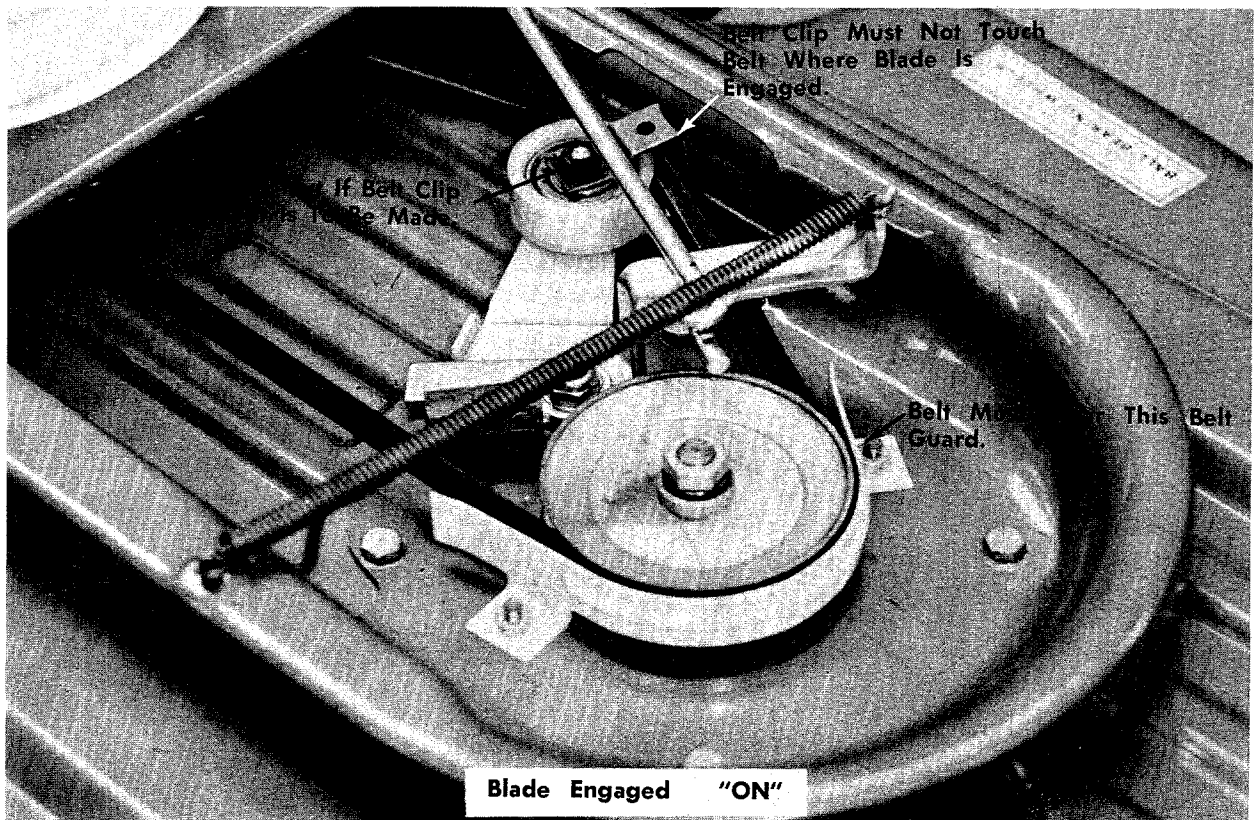
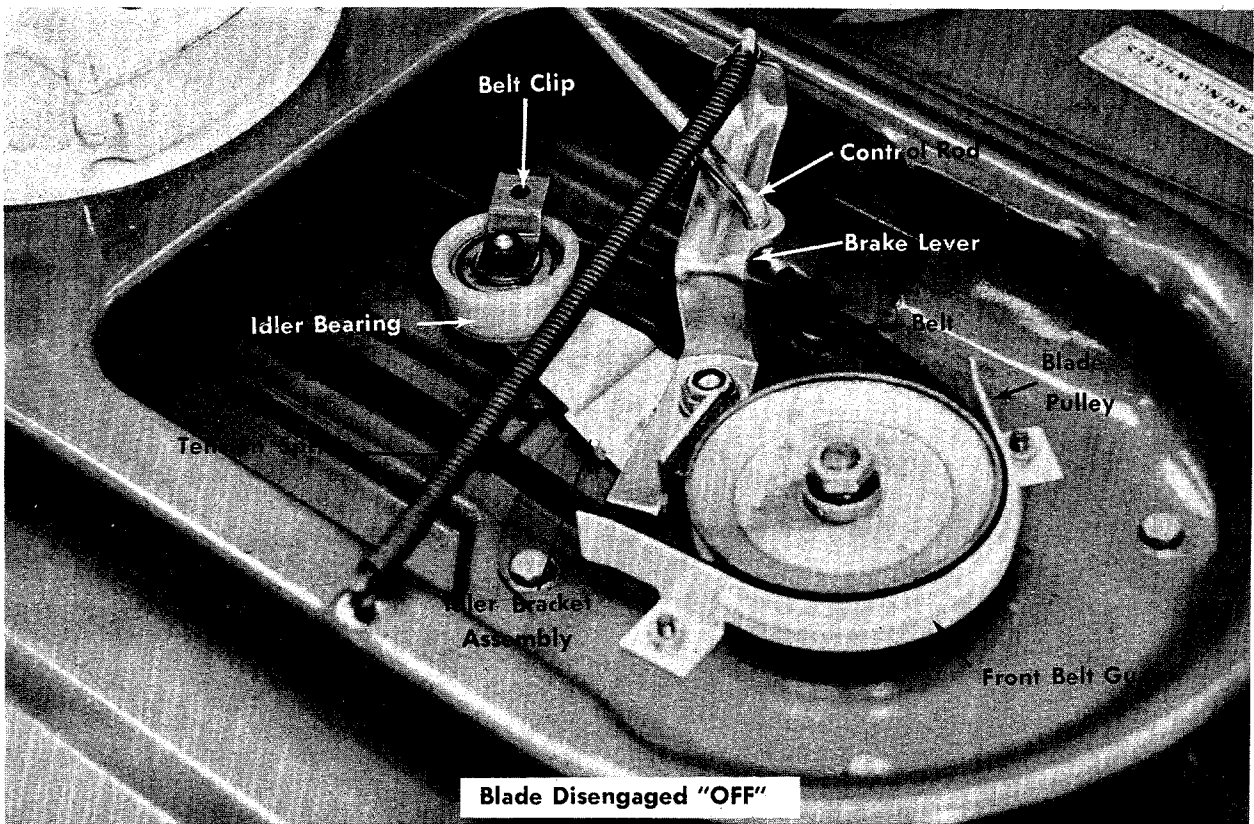

# 116-530A

IF YOU WRITE TO US ABOUT THIS ARTICLE  
OR IF YOU ORDER REPLACEMENT PARTS AL-  
WAYS MENTION THIS MODEL & SERIAL NO  
MODEL

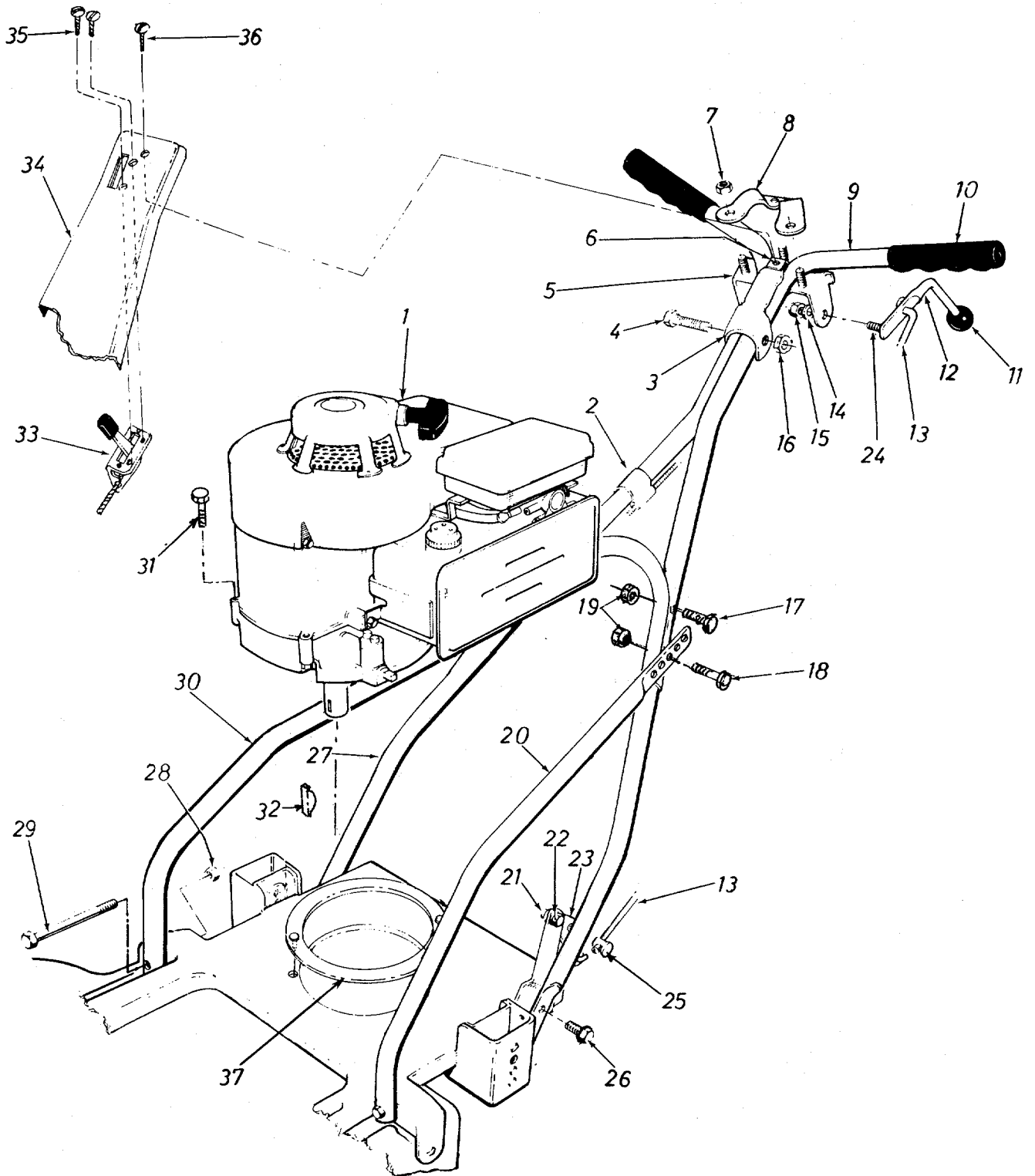

**PARTS LIST FOR MODEL 116-530A**

REF. NO.	PART NO.	COLOR CODE	DESCRIPTION	NEW PART
1	—		Engine	
2	746-0128		Cable Clip for 7/8" Tubing	
3	07861		Clamp Bracket	
4	710-0136		Hex Scr. 1/4-20 x 1.75" Lg.*	
5	08376		Lockout Brkt. Ass'y.	
6	712-0526		Speed Nut #10-24	
7	712-0107		Hex Center L-Nut 1/4-20 Thd.	
8	08378		Clamp Bracket	
9	09354		Upper Handle (2-Req'd)	
10	720-0157		Grip	
11	07889		Plastic Ball	
12	08373		Lockout Lever Ass'y with Plastic Ball	
13	711-0180		Control Rod	
14	736-0108		Fl. Wash. .510 I.D. x .750 O.D.	
15	712-0117		Hex Cent. L-Nut 1/4-28 Thd.	
16	712-0107		Hex Center L-Nut 1/4-20 Thd.	
17	710-0606		Hex Scr. 1/4-20 x 1.50 Lg.	
18	710-0606		Hex Scr. 1/4-20 x 1.50" Lg.*	
19	712-0107		Hex Center L-Nut 1/4-20 Thd.	
20	08327		Lower Handle Support—L.H.	
21	712-0181		Hex Top L-Nut 3/8-16 Thd.	
22	738-0234		Shld. Scr. .500" Dia. x .295	
23	09372		Pivot Bracket	
24	710-0412		Hex Scr. 1/4-28 x .75" Lg. Gr. 5	
25	711-0179		Adjustable Ferrule	
26	710-0209		Hex Sems Scr. 3/8-16 x .62	
27	09362		Lower Handle	
28	712-0107		Hex Center L-Nut 1/4-20 Thd.	
29	710-0102		Hex Scr. 1/4-20 x 2.50" Lg.*	
30	08328		Lower Handle Support—R.H.	
31	710-0158		Hex Scr. 5/16-24 x 1.25"	
32	714-0365		#6 Hi-Pro Key 5/32 x 5/8 Dia.	
33	746-0171		Throttle	
34	11815 —463		Control Panel	
35	710-0227		Hex Wash. Hd. AB-Tapp Scr. #8 x .38" Lg.	
36	710-0192		Truss Mach. Scr. #10-24 x .38	
37	08325 —463		Belt Trap Ass'y.	

\*For faster service obtain standard nuts, bolts and washers locally. If these items cannot be obtained locally, order by part number and size as shown on parts list.

(463—Top Flite Red)

When ordering parts, if color or finish is important, use the appropriate color code shown at left. (e.g. Top Flite Red Finish—11815 (463))

The engine is not under warranty by the mower manufacturer. If repairs or service is needed on the engine, please contact your nearest authorized engine service outlet. Check the "Yellow Pages" of your telephone book under "Engines — Gasoline."



116-530A

IF YOU WRITE TO US ABOUT THIS ARTICLE  
OR IF YOU ORDER REPLACEMENT PARTS AL-  
WAYS MENTION THIS MODEL & SERIAL NO  
M O D E L

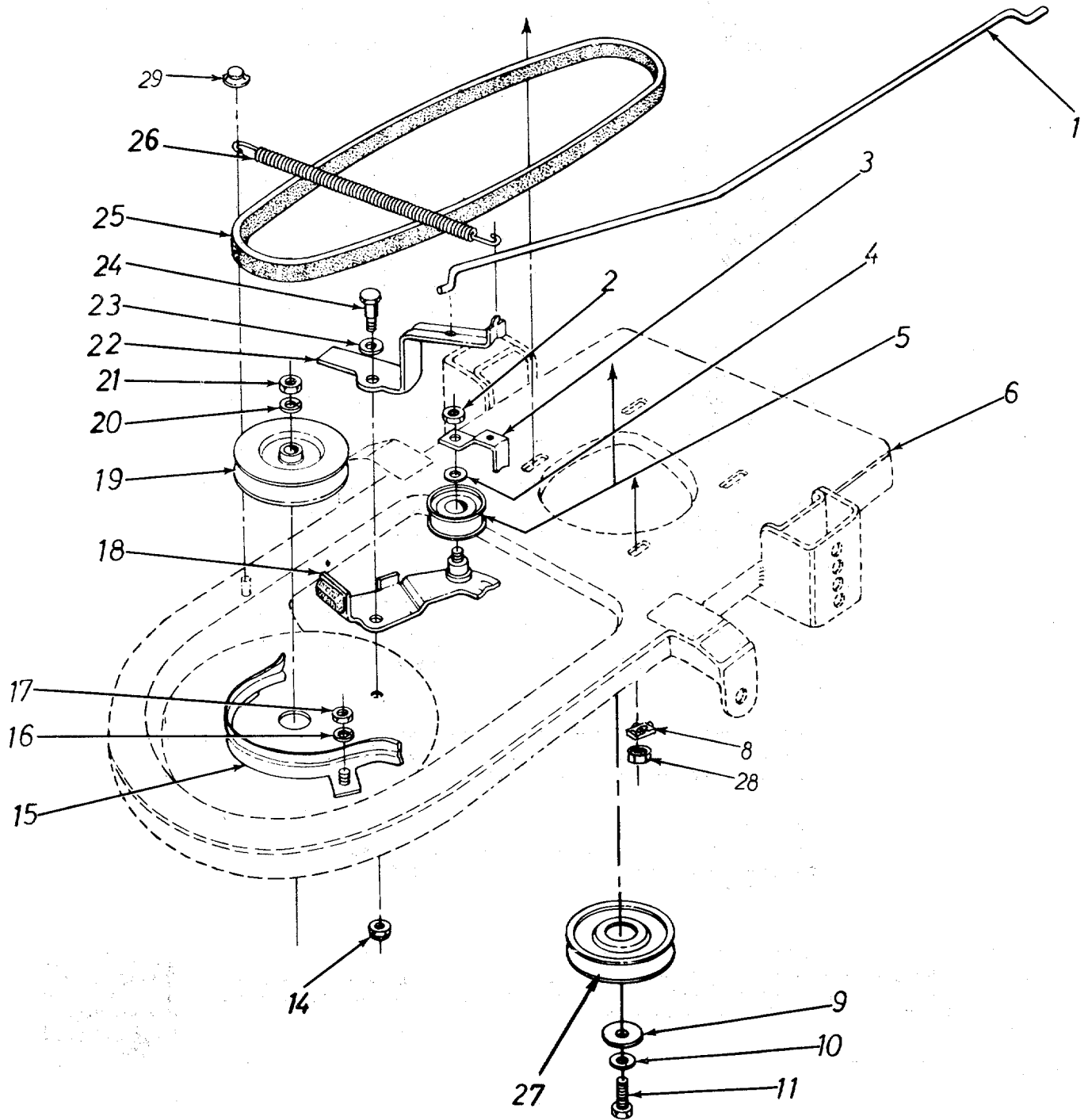



**PARTS LIST FOR MODEL 116-530A**

REF. NO.	PART NO.	COLOR CODE	DESCRIPTION	NEW PART
1	09373		Control Rod	
2	712-0262		Hex Ins. Jam Nut 3/8-24 Thd.	
3	04563		Belt Clip	
4	736-0300		Fl. Wash.	
5	756-0199		Flat Idler with Flange	
6	12581 —463		Frame Ass'y.	
8	736-0170		Special L-Wash. 5/16" Scr.	
9	07386		Fl. Wash. .406" I.D. x 1.25" O.D. x .164	
10	736-0169		Spring L-Wash. 3/8" Scr.	
11	710-0152		Hex Scr. 3/8-24 x 1.00" Lg. H.T.	
14	712-0181		Hex Top L-Nut 3/8-16 Thd.	
15	08324 —463		Belt Guard	
16	736-0329		Spring L-Wash. 1/4" Scr.*	
17	712-0287		Hex Nut 1/4-20 Thd.*	
18	12278		Idler Brkt. Ass'y. w. Brake Shoe	
19	09925		Sheave Ass'y.—4" Dia. (Blade Spindle)	
20	736-0921		Spring L-Wash. 1/2" Scr.*	
21	712-0200		Hex Ins. Nut 1/2-20 Thd.	
22	09371		Brake Lever	
23	736-0463		Fl. Wash. .296 I.D. x .62" O.D. x .059	
24	738-0234		Shoulder Scr. .500" Dia. x .295	
25	754-0109		"V"-Belt 1/2" x 43" Lg.	
26	732-0158		Blade Tension Spring	
27	756-0206		Engine Pulley 4.00" O.D.	
28	712-0123		Hex Nut 5/16-24 Thd.	
29	726-0111		Push Cap	

\*For faster service obtain standard nuts and bolts locally. If these items cannot be obtained locally, order by part number and size as shown on the parts list.

(463—Top Flite Red)

When ordering parts, if color or finish is important, use the appropriate color code shown at left. (e.g. Top Flite Red Finish—11815 (463))

The engine is not under warranty by the mower manufacturer. If repairs or service is needed on the engine, please contact your nearest authorized engine service outlet. Check the "Yellow Pages" of your telephone book under "Engines—Gasoline."

Find It Fast  
In The  
**'Yellow Pages'**



# 116-530A

IF YOU WRITE TO US ABOUT THIS ARTICLE  
OR IF YOU ORDER REPLACEMENT PARTS AL-  
WAYS MENTION THIS MODEL & SERIAL NO  
MODEL

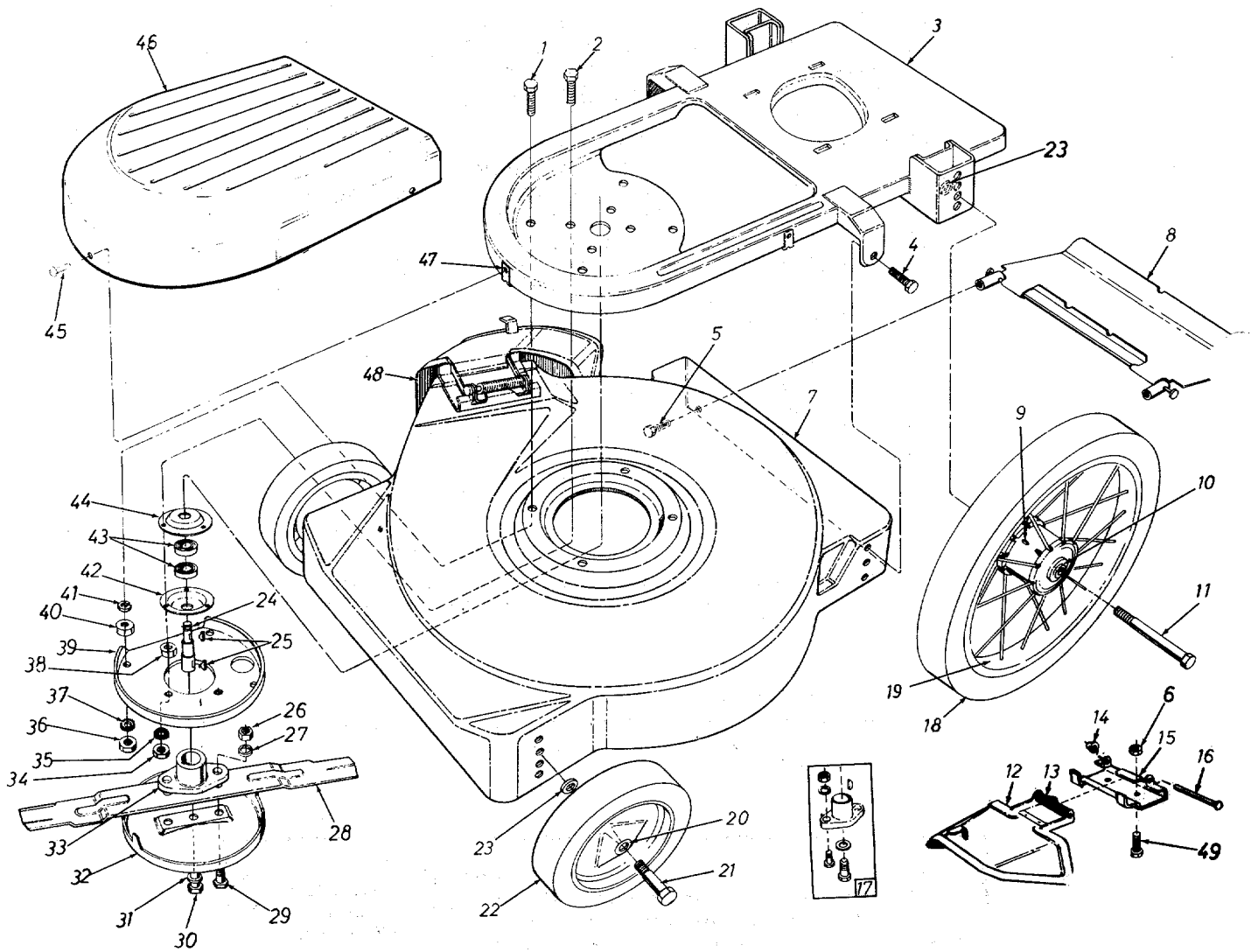

**PARTS LIST FOR MODEL 116-530A**

REF. NO.	PART NO.	COLOR CODE	DESCRIPTION	NEW PART	REF. NO.	PART NO.	COLOR CODE	DESCRIPTION	NEW PART
1	710-0116		Hex Scr. 5/16-18 x 2.00"		25	714-0365		#6 Hi-Pro Key 5/32 x 5/8" Dia.	
2	710-0158		Hex Scr. 5/16-24 x 1.25" Lg.*		26	712-0123		Hex Nut 5/16-18 Thd.*	
3	12581 —463		Frame Ass'y.		27	736-0199		L-Wash. 5/16" Scr.*	
4	710-0209		Hex Sems Scr. 3/8-16 x .62" Lg.*		28	742-0125		22" Blade	
5	710-0567		Hex Sems Scr. 1/4-28 x 5/8" Lg.		29	710-0117		Hex Scr. 5/16-24 x 1.00" H.T.	
6	712-0107		Hex Cent. L-Nut 1/4-20		30	710-0459		Hex Scr. 3/8-24 x 1.50" Lg. H.T.	
7	12422 —463		Deck Ass'y.—22 in.		31	736-0217		Spring L-Wash. 3/8" Scr. H.D.	
8	11193		Protective Shield Ass'y.—Comp.		32	07919		Scalp Plate	
9	718-0132		Oil Cap		33	10769		Blade Adapter Kit	
10	741-0113		Ball Brg. .504 I.D. x 1.38 Dia.		34	712-0123		Hex Nut 5/16-24 Thd.*	
11	738-0114		Shoulder Scr. .498" Dia. x 4.755"		35	736-0119		L-Wash. 5/16" Scr.*	
12	11679 —463		Chute Deflector Ass'y.		36	712-0267		Hex Nut 5/16-18 Thd.*	
13	732-0253		Torsion Spring		37	736-0119		Spring L-Wash. 5/16" Scr.*	
14	726-0106		Push Cap		38	712-0123		Hex Nut 5/16-18 Thd.*	
15	11130 —463		Adapter Plate		39	12281		Blade Reinforcement Plate	
16	711-0555		Pivot Pin		40	712-0267		Hex Nut 5/16-18 Thd.*	
17	10769		Blade Adapter Kit		41	736-0119		L-Wash. 5/16" Scr.*	
18	734-0439		16" Rear Wheel Ass'y.—Comp.		42	08253		Bearing Housing	
19	734-0180		16" Rear Wheel—Less Tire		43	741-0919		Ball Bearing	
	734-0392		Semi Pneumatic Tire 16 x 1.75		44	08253		Bearing Housing	
20	741-0178		Ball Brg. .38 I.D.		45	710-0192		Truss Hd. Mach. Scr. 10-24 x .38 Lg.	
21	710-0427		Hex Scr. 3/8-16 x 2.00" Lg.*		46	08295 —452		Blade Spindle Cover	
22	734-0643		Front Wheel Ass'y. Comp.		47	712-0526		Speed Nut #10-24	
23	736-0105		Belleville Washer		48	11679 —463		Chute Deflector Ass'y.—Comp.	
24	738-0251		Blade Spindle		49	710-0289		Hex Scr. 1/4-20 x .50	

\*For faster service obtain standard nuts, bolts and washers locally. If these items cannot be obtained locally, order by part number and size as shown on parts list.

(463—Top Flite Red)

When ordering parts, if color or finish is important, use the appropriate color code shown at left. (e.g. Top Flite Red Finish—11815 (463))

The engine is not under warranty by the mower manufacturer. If repairs or service is needed on the engine, please contact your nearest authorized engine service outlet. Check the "Yellow Pages" of your telephone book under "Engines — Gasoline."





**NOTE**

The manufacturer DOES NOT recommend the use of any accessory on this rotary mower other than those manufactured by MTD Products Inc.

GRASS CATCHER Model No. 196-003A is available as optional equipment for the mowers shown in this manual.



1. The mower should not be operated without the entire grass catcher or chute deflector in place.
2. The mower should not be operated without the protective shield on the rear of the deck in place.



**NOTE:**

Under normal usage bag material is subject to wear and should be checked periodically. Be sure any replacement bag complies with the mower manufacturer's recommendations.

For replacement bags, use only factory authorized replacement bag No. 764-0119.



**IMPORTANT**

After striking a foreign object, stop the engine, remove wire from spark plug. Thoroughly inspect the mower for any damage, and repair the damage before restarting and operating the mower.

# PARTS INFORMATION

## POWER EQUIPMENT PARTS AND SERVICE

Parts and service for all MTD manufactured power equipment are available through the authorized service firms listed below. All orders should specify the model number of your unit, parts numbers, description of parts and the quantity of each part required.

<b>ALABAMA</b>	<b>BIRMINGHAM</b>	
	Auto Electric & Carburetor Co.	2625 4th Ave. S. .... 35233
<b>ARKANSAS</b>	<b>NORTH LITTLE ROCK</b>	
	Sutton's Lawn Mower Shop	Rt. 4, Box 368 ..... 72117
	<b>FORT SMITH</b>	
	Mity Mite Motors, Inc.	2515 Towson Ave. .... 72901
<b>CALIFORNIA</b>	<b>SAN BERNARDINO</b>	
	Lawn Mower Supply Co.	25608 E. Baseline .... 92410
	<b>SAN FRANCISCO</b>	
	J.W. Jewett Co.	981 Folsom St. .... 94107
	<b>SACRAMENTO</b>	
	Luttig & Severson	2030 28th St. .... 95818
<b>COLORADO</b>	<b>DENVER</b>	
	South Denver Lawn Equip.	527 West Evans ..... 80223
<b>CONNECTICUT</b>	<b>SUFFIELD</b>	
	The Jones & Ramsey Co.	850 Thompsonville Rd. 06078
<b>FLORIDA</b>	<b>JACKSONVILLE</b>	
	Radco Distributors	2403 Market St. .... 32206
	<b>CORAL GABLES</b>	
	Mox-All of Florida, Inc.	365 Greco Ave. .... 33146
<b>GEORGIA</b>	<b>EAST POINT</b>	
	East Point Cycle & Key	2834 Church St. .... 30344
<b>ILLINOIS</b>	<b>LYONS</b>	
	Keen Edge Co.	8615 Ogden Ave. .... 60534
<b>INDIANA</b>	<b>ELKHART</b>	
	Parts & Sales Inc.	2101 Industrial Pkwy. .46514
	<b>CORYDON</b>	
	Brown Equip. Dist., Inc.	110 Beech St. ....47112
<b>IOWA</b>	<b>DUBUQUE</b>	
	Power Lawn & Garden Equip.	2551 J.F. Kennedy .... 52001
<b>KANSAS</b>	<b>WICHITA</b>	
	Hixon, Inc.	3030 Mascot ..... 67204
<b>LOUISIANA</b>	<b>NEW ORLEANS</b>	
	Suhren Engine Co.	8330 Earhart Blvd. .... 70118
<b>MARYLAND</b>	<b>TAKOMA PARK</b>	
	Center Supply Co.	6867 New Hampshire Ave. 20012
<b>MASSACHUSETTS</b>	<b>SPRINGFIELD</b>	
	Morton B. Collins Co.	300 Birnie Ave. .... 01107
<b>MICHIGAN</b>	<b>MOUNT CLEMENS</b>	
	Power Equipment Dist.	36463 South Gratiot... 48043
	<b>LANSING</b>	
	Lorenz Service Co.	2500 S. Pennsylvania.. 48900
<b>MINNESOTA</b>	<b>MINNETONKA</b>	
	Hance Distributing Inc.	11212 Wayzata Blvd. .55343
<b>MISSISSIPPI</b>	<b>BILOXI</b>	
	Biloxi Sales & Service, Inc.	506 Caillavet St. .... 39533
<b>MISSOURI</b>	<b>KANSAS CITY</b>	
	Automotive Equip. Service	3117 Holmes St. .... 64109
	<b>ST. LOUIS</b>	
	Henzler, Inc.	2015 Lemay Ferry Rd. 63125
<b>NEBRASKA</b>	<b>OMAHA</b>	
	R.P.W., Inc.	7402 "L" St. .... 68127

## BRIGGS & STRATTON, TECUMSEH AND PEERLESS PARTS AND SERVICE

Briggs & Stratton, Tecumseh and Peerless parts or service should be handled by your nearest authorized engine service firm. Check the yellow pages of your telephone directory under the listing *Engines Gasoline*, Briggs & Stratton or Tecumseh Lauson

<b>NEW YORK</b>	<b>CARTHAGE</b>	
	Gamble Dist., Inc.	West End Ave. .... 13619
	<b>SYRACUSE</b>	
	Kimber's, Inc.	115 N. Geddes St. .... 13204
	<b>ROCHESTER</b>	
	Henry W. O'Neil & Associates	410 N. Goodman St. ... 14609
<b>NORTH CAROLINA</b>	<b>GREENSBORO</b>	
	Dixie Sales Company	327 Battleground Ave.. 27402
	<b>GOLDSBORO</b>	
	Smith Hardware Co.	515 N. George St. .... 27530
<b>OHIO</b>	<b>WADSWORTH</b>	
	National Central	687 Seville Rd. .... 44281
	<b>CLEVELAND</b>	
	Bleckrie, Inc.	7900 Lorain Ave. .... 44102
	<b>CARROL</b>	
	Stebe's Mid-State Mower Supply	Box 366 ..... 43112
	<b>WILLARD</b>	
	Sunshine Wholesale Tire Outlet	Route 224 ..... 44890
	<b>MANSFIELD</b>	
	McClure Lawn & Garden Supply	1114 Lexington Ave. . 44903
<b>OKLAHOMA</b>	<b>MUSKOGEE</b>	
	Victory Motors, Inc.	605 S. Cherokee ..... 74401
	<b>ADA</b>	
	Ada Auto Supply	301 E. 12th St. .... 74820
<b>OREGON</b>	<b>PORTLAND</b>	
	Kenton Supply Co.	8216 N. Denver Ave. . 97217
<b>PENNSYLVANIA</b>	<b>LANCASTER</b>	
	Raub Supply Co.	James & Mulberry Sts... 17604
	<b>PITTSBURGH</b>	
	Bluemont Co.	11125 Frankstown Rd.. 1521
<b>TENNESSEE</b>	<b>KNOXVILLE</b>	
	Master Repair Service	2423 Broadway, N.E. .37917
	<b>MEMPHIS</b>	
	Memphis Cycle & Supply Co.	421 Monroe Ave. .... 38103
	American Sales & Service, Inc.	1922 Lynnbrook ..... 38117
<b>TEXAS</b>	<b>DALLAS</b>	
	Marr Brothers, Inc.	423 E. Jefferson ..... 75203
	<b>HOUSTON</b>	
	Bullard Supply Co.	2409 Commerce St. .... 77003
	<b>SAN ANTONIO</b>	
	Catto & Putty, Inc.	P.O. Box 2408 ..... 78206
	<b>FORT WORTH</b>	
	Woodson Sales Corp.	1702 N. Sylvania ..... 76111
<b>UTAH</b>	<b>SALT LAKE CITY</b>	
	A-1 Engine & Mower Co.	437 E. 9th St. .... 84111
<b>VERMONT</b>	<b>BURLINGTON</b>	
	Vermont Appliance Co.	44 Lakeside Ave. .... 05401
<b>VIRGINIA</b>	<b>RICHMOND</b>	
	RBI Corp.	963 Myers St. .... 23260
<b>WASHINGTON</b>	<b>SEATTLE</b>	
	Bailey's Rebuild, Inc.	1325 E. Madison St. ... 98102
<b>WEST VIRGINIA</b>	<b>CHARLESTON</b>	
	Young's, Inc.	233 Virginia St., E. ... 25301
<b>WISCONSIN</b>	<b>APPLETON</b>	
	Automotive Supply Co.	123 S. Linwood Ave. .54911

## WARRANTY PARTS AND SERVICE POLICY

The purpose of warranty is to protect the customer from defects in workmanship and materials, defects which are NOT detected at the time of manufacture. It does not provide for the unlimited and unrestricted replacement of parts. Use and maintenance are the responsibility of the customer. The manufacturer cannot assume responsibility for conditions over which it has no control. Simply put, if it's the manufacturer's fault, it's the manufacturer's responsibility; if it's the customer's fault, it's the customer's responsibility.

### CLAIMS AGAINST THE MANUFACTURER'S WARRANTY INCLUDES

1. Replacement of Missing Parts on new equipment.
2. Replacement of Defective Parts within the warranty period.
3. Repair of Defects within the warranty period.

All claims MUST be substantiated with the following information:

1. Model Number of unit involved.
2. Date unit was purchased or first put into service.
3. Date of failure.
4. Nature of failure.