

OWNER'S GUIDE

OUTDOOR POWER EQUIPMENT
for all seasons

Spring

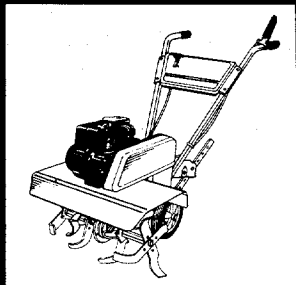

Summer

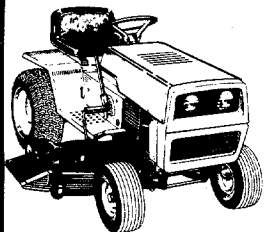

Fall

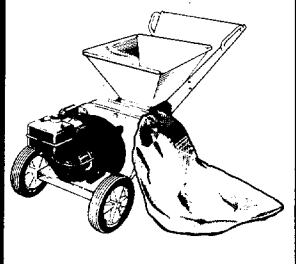

Winter

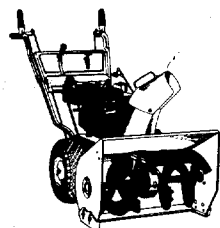

21" SIDE AND TOP DISCHARGE ROTARY MOWERS

Model Numbers
116-102-000
116-112-000

Important:
Read Safety Rules and
Instructions Carefully

Thank you for purchasing
an American-built product.

INDEX

Safe Operation Practices	3	Maintenance	12
Assembly	4	Off-Season Storage	13
Controls	9	Illustrated Parts	16
Operation	10	Repair Parts List	17
Adjustments	11	Trouble Shooting	15
Lubrication	12	Parts Information	Back Cover



Instructions given with this symbol are for personal safety. Be sure to follow them.

LIMITED WARRANTY

For one year from the date of original retail purchase, MTD PRODUCTS INC will either repair or replace, at its option, free of charge, F.O.B. factory or authorized service firm, any part or parts found to be defective in material or workmanship. Transportation charges for the movement of any power equipment unit or attachment are the responsibility of the purchaser. Transportation charges for any parts submitted for replacement under this warranty must be paid by the purchaser unless such return is requested by MTD PRODUCTS INC.

This warranty will not apply to any part which has become inoperative due to misuse, excessive use, accident, neglect, improper maintenance, alterations, or unless the unit has been operated and maintained in accordance with the instructions furnished. This warranty does not apply to the engine, motor, battery, battery charger or component parts thereof. Please refer to the applicable manufacturer's warranty on these items.

This warranty will not apply where the unit has been used commercially.

Warranty service is available through your local authorized service dealer or distributor. If you do not know the dealer or distributor in your area, please write to the Customer Service Department of MTD.

The return of a complete unit will not be accepted by the factory unless prior written permission has been extended by MTD.

This warranty gives you specific legal rights. You may also have other rights which vary from state to state.



WARNING

This unit is equipped with an internal combustion engine and should not be used on or near any unimproved forest-covered, brush-covered or grass-covered land unless the engine's exhaust system is equipped with a spark arrester meeting applicable local or state laws (if any). If a spark arrester is used, it should be maintained in effective working order by the operator.

In the State of California the above is required by law (Section 4442 of the California Public Resources Code). Other states may have similar laws. Federal laws apply on federal lands. A spark arrester muffler is available at your nearest engine authorized service center.



WARNING

To reduce the potential for any injury, comply with the following safety instructions. Failure to comply with the instructions may result in personal injury.

SAFE OPERATION PRACTICES FOR WALK-BEHIND MOWERS

TRAINING

1. Read this owner's manual carefully in its entirety before attempting to assemble or operate this machine. Be completely familiar with the controls and the proper use of this machine before operating it. Keep this manual in a safe place for future and regular reference and for ordering replacement parts.
2. Your rotary mower is a precision piece of power equipment, not a plaything. Therefore, exercise extreme caution at all times.
3. Never allow children to operate a power mower. Only persons well acquainted with these rules of safe operation should be allowed to use your mower.
4. No one should operate this unit while intoxicated or while taking medication that impairs the senses or reactions.
5. Keep the area of operation clear of all persons, particularly small children and pets. Stop engine when they are in the vicinity of your mower. Although the area of operation should be completely cleared of foreign objects, an object may have been overlooked and could be accidentally thrown by the mower in any direction and cause serious personal injury to the operator or any others allowed in the area.

PREPARATION

1. Thoroughly inspect the area where the equipment is to be used. Remove all stones, sticks, wire, bones and other foreign objects which could be picked up and thrown by the mower in any direction and cause serious personal injury to the operator or any others allowed in the area.
2. Do not operate equipment when barefoot or wearing open sandals. Always wear substantial footwear.
3. Do not wear loose fitting clothing that could get caught on the mower.
4. Check the fuel before starting the engine. Gasoline is an extremely flammable fuel. Do not fill the gasoline tank indoors, while the engine is running, or while the engine is still hot. Replace gasoline cap securely and wipe off any spilled gasoline before starting the engine as it may cause a fire or explosion.
5. Disengage the self-propelled mechanism or drive clutch on units so equipped before starting the engine.
6. The blade control handle is a safety device. Never attempt to bypass its operation. Doing so makes the safety device inoperative and may result in personal injury through contact with the rotating blade. The blade control handle must operate easily in both directions.
7. Never attempt to make a wheel or cutting height adjustment while the engine is running.
8. Mow only in daylight or in good artificial light.
9. Never operate the equipment in wet grass. Always be sure of your footing. A slip and fall can cause serious personal injury. Keep a firm hold on the handle and walk, never run.

10. Always wear safety glasses or eye shields during operation or while performing an adjustment or repair, to protect eyes from foreign objects that may be thrown from the machine in any direction.

OPERATION

1. Do not change the engine governor settings or over-speed the engine. Excessive engine speeds are dangerous.
2. Do not put hands or feet near or under rotating parts. Keep clear of the discharge opening at all times as the rotating blade can cause injury.
3. Stop the blade when crossing gravel drives, walks or roads.
4. After striking a foreign object, stop the engine, remove the wire from the spark plug, and thoroughly inspect the mower for any damage. Repair the damage before restarting and operating the mower.
5. If the equipment should start to vibrate abnormally, stop the engine and check immediately for the cause. Vibration is generally a warning of trouble.
6. Shut the engine off and wait until the blade comes to a complete stop before removing the grass catcher or unclogging the chute. The cutting blade continues to rotate for a few seconds after the engine is shut off. Never place any part of the body in the blade area until you are sure the blade has stopped rotating.
7. Before cleaning, repairing or inspecting, make certain the blade and all moving parts have stopped. Disconnect the spark plug wire, and keep the wire away from the spark plug to prevent accidental starting.
8. Do not run the engine indoors.
9. Mow across the face of slopes, never up-and-down. Exercise extreme caution when changing direction on slopes. Do not mow excessively steep slopes. Always be sure of your footing. A slip and fall can cause serious personal injury.
10. Always disconnect electric mowers (line operated) before cleaning, repairing or adjusting.
11. Never operate mower without proper guards, plates or other safety protective devices in place.
12. **DO NOT OPERATE** top discharge mowers with the chute door open, unless the complete grass catcher is properly mounted on the mower.

MAINTENANCE AND STORAGE

1. Check the blade and engine mounting bolts at frequent intervals for proper tightness.
2. Keep all nuts, bolts, and screws tight to be sure the equipment is in safe working condition.
3. Never store the equipment with gasoline in the tank inside of a building where fumes may reach an open flame or spark. Allow the engine to cool before storing in any enclosure.
4. To reduce fire hazard, keep the engine free of grass, leaves, or excessive grease.
5. Check the grass catcher bag frequently for wear or deterioration. For safety protection, replace only with new bag meeting original equipment specifications.

This owner's manual covers both side discharge (Model 102) and top discharge (Model 112) rotary mowers. Follow only the instructions which pertain to your style mower.

NOTE

This unit is shipped WITHOUT GASOLINE or OIL. After assembly, see separate engine manual for proper fuel and engine oil recommendations.

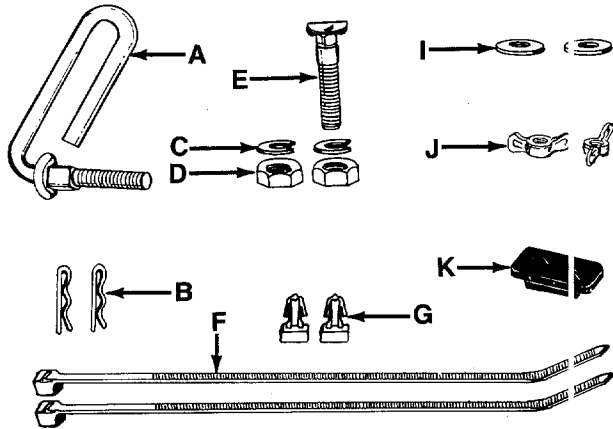

FIGURE 1.

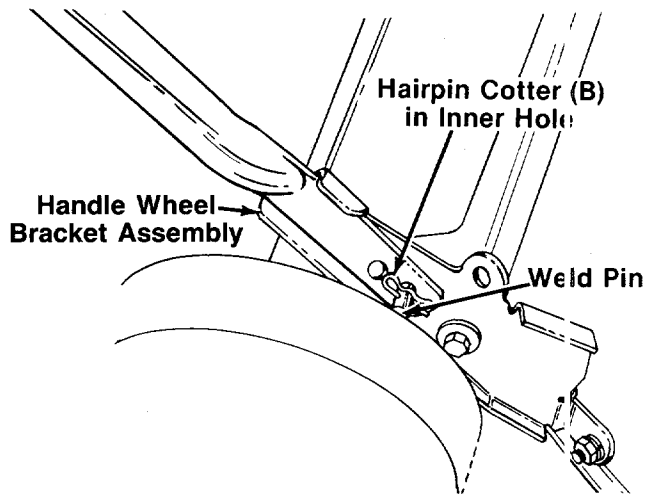

FIGURE 2.

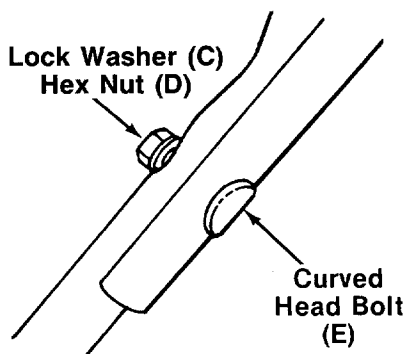

FIGURE 3.

ASSEMBLY INSTRUCTIONS

NOTE

Reference to right or left hand side of the mower is observed from the operating position.

Contents of Hardware Pack: (See Figure 1)

- A (1) Rope Guide Bolt
- B (2) Hairpin Cotter
- C (2) Lock Washers 5/16" I.D.
- D (2) Hex Nuts 5/16-18 Thread
- E (1) Curved Head Carriage Bolt
- F (2) Cable Ties
- G (2) Plastic Cable Anchors
- H (1) Cable Clamp (Not Shown)
- I (2) Flat Washers 1/4" I.D.*
- J (2) Wing Nuts*
- K (1) Plastic Plug* (May Be Already Assembled)

*Side discharge mowers (Model 102) only.

Loose Parts in Carton:

- (1) Lower Handle
- (1) Upper Handle
- (1) Side Chute Deflector (Optional)
- (1) Grass Catcher Handle**
- (1) Front Catcher Frame**
- (1) Grass Catcher Bag**

**Top discharge mowers (Model 112) only.

1. Remove lawn mower and loose parts from carton. Make certain all parts and literature have been removed from the carton before the carton is discarded.
2. Extend the throttle control cable (attached to the upper handle) and the brake cable (attached to the engine) and place on the floor. Be careful not to bend or kink control cables.
3. Attach the lower handle by placing the bottom holes in the lower handle over the weld pins on the handle wheel bracket assemblies. Make certain the instruction label on the lower handle can be read from the operating position. Secure with hairpin cotters (B) in inner holes on weld pins. See figure 2.

NOTE

It may be necessary to bend the ends of the lower handle inward slightly to obtain a tight fit against the handle mount brackets.

4. Place the upper handle in position over the lower handle. The control housing must be on the left hand side of the handle. Secure the left hand side of upper handle using the curved head bolt (E), lock washer (C) and hex nut (D) as shown in figure 3.

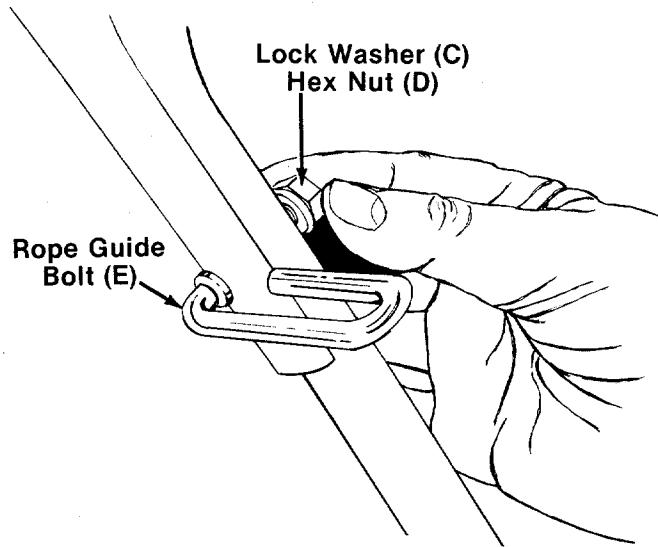

5. Insert the rope guide bolt (A) through the right hand side of upper and lower handle. Secure finger tight only with lock washer (C) and hex nut (D). See figure 4.

FIGURE 4.

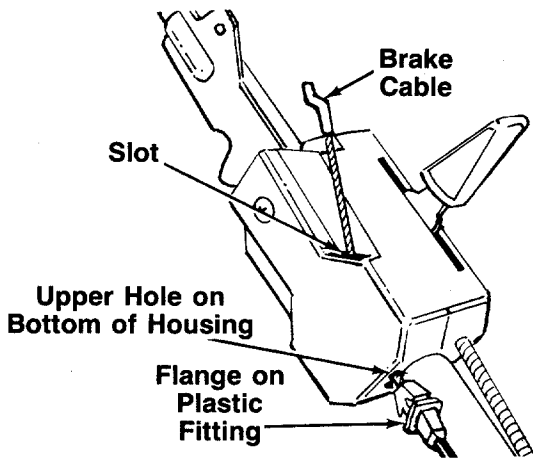

6. Route the brake cable under the lower handle. Place the end of the brake cable into the upper hole on the bottom of the control housing, and through the slot in the side of the housing as shown in figure 5. The angle of the flange on the plastic fitting must be positioned downward as shown. Be careful not to bend or kink the cable.



Brake cable must be assembled as shown for proper blade brake operation.

FIGURE 5.

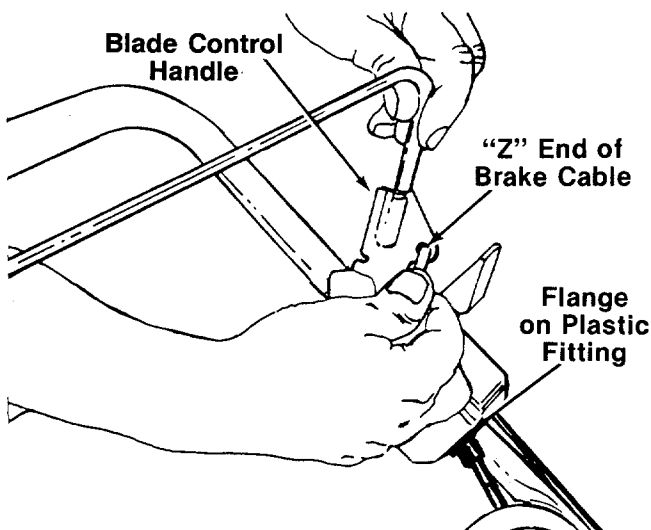

7. Snap the plastic fitting on the end of the cable into the control housing. Hook the "Z" end of the brake cable into the hole in the blade control handle. See figure 6.

FIGURE 6.

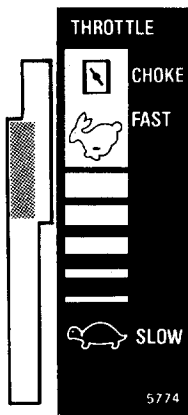

FIGURE 7.

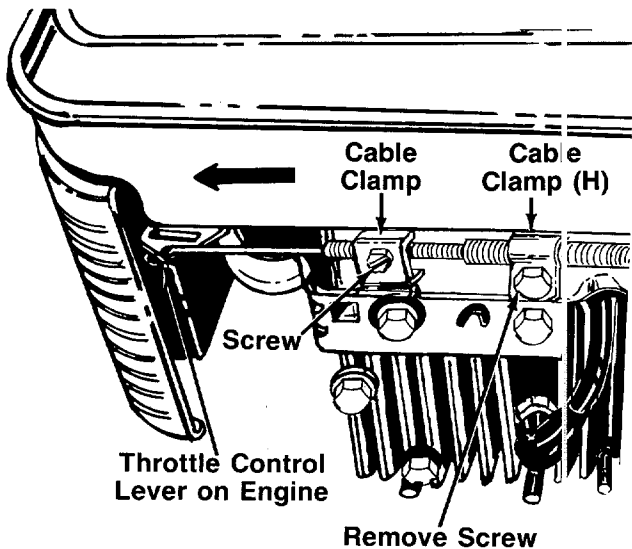

FIGURE 8.

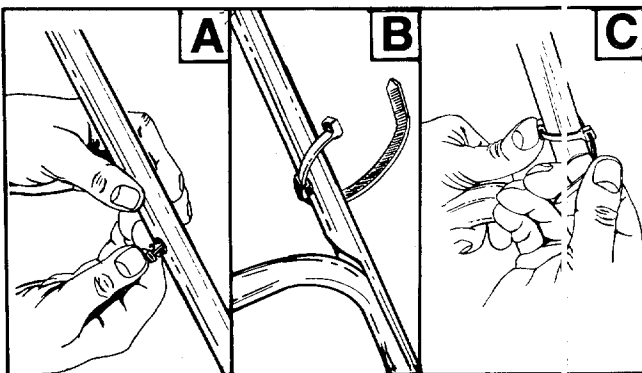

FIGURE 9.

8. Move throttle control lever on handle forward until it stops in FAST position. (**Do not** push all the way forward to CHOKE position.) See figure 7.

9. Route the throttle control cable under the lower handle inside of handle bracket assembly and through the catcher panel opening (next to brake cable). Hook the "Z" end of the throttle control cable into the hole in the control lever on the engine.

10. Using a 7/16" wrench, remove the screw on the engine shown in figure 8.

11. Remove the screw on the cable clamp shown in figure 8. Slip the control casing under the clamp. Replace the screw, but do not tighten (cable must still move freely beneath the clamp).

12. Slide the throttle control lever on the engine as far toward the **outside** of the engine as it will go **easily** (just until resistance is felt) as shown in figure 8. (**Do not** force it into the extreme outside position, which is the CHOKE position). Tighten the screw to secure the throttle control cable in this position.

13. Loosen the screw on the clamp on the side of the engine. Slip the cable casing under the clamp to secure the cable **away from the muffler**. Be careful not to bend or kink the cable. Tighten the screw.

14. Secure cable casing to the front of engine with cable clamp (H) provided in hardware pack and screw removed from engine in step 10. Do not overtighten.

15. Secure brake and throttle cables to the left side of the handle as follows.

A. Insert plastic cable anchors (G) into holes provided on the inside of the lower handle, one near the top and one near the bottom of lower handle. See figure 9A.

B. Slip cable ties (F) through cable anchors so the teeth in the cable tie will be against the handle (smooth side is away from the handle). See figure 9B.

C. Secure the cables with the cable ties. See figure 9C.

D. Cut off excess ends of cable ties.

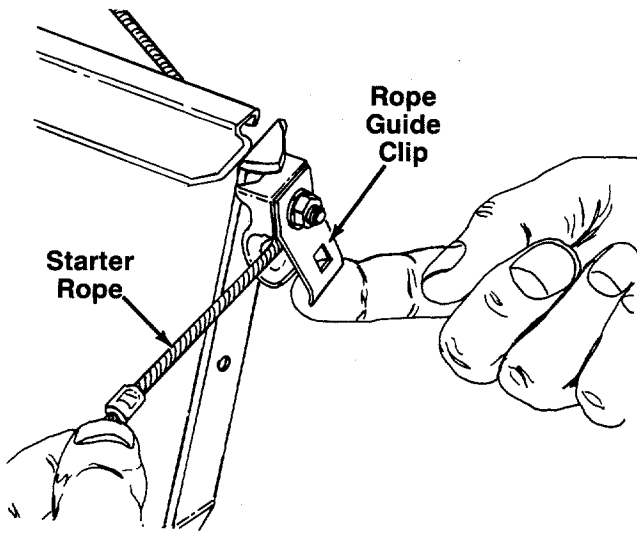

FIGURE 10.

16. Disconnect and ground the spark plug wire. Depress the blade control handle and pull the starter rope out from the engine. Hold the rope so it does not retract into the engine.

17. **Top Discharge Models Only (Model 112):** Slip the starter rope under the rope guide clip. As shown in figure 10.

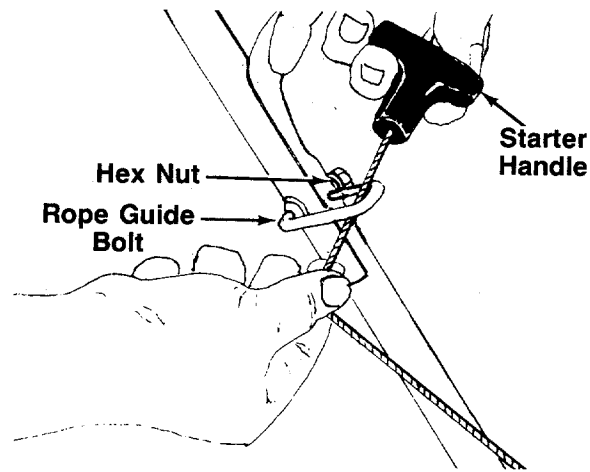

FIGURE 11.

18. Slip the starter rope into the rope guide bolt as shown in figure 11. Tighten the hex nut on the rope guide bolt securely.

19. Attach hub caps (optional) to the wheels by lining up cap with hub of wheel. Push to snap in place.

20. Check all nuts and bolts for correct tightness.

IMPORTANT

If your unit is equipped with both a side chute deflector and top discharge chute and grass bag, follow the instructions for top discharge mowers. After assembly is completed, it can then easily be converted to a side discharge mower.

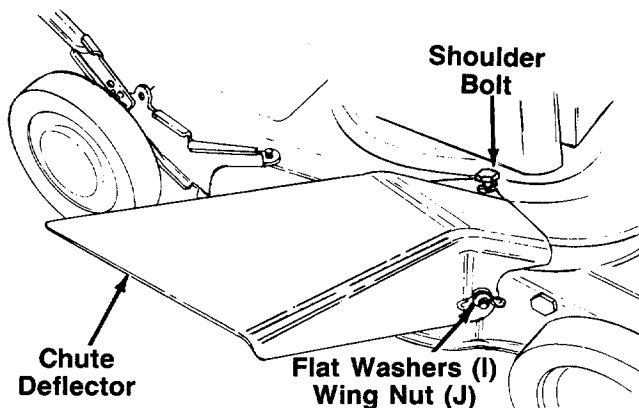

FIGURE 12.

SIDE DISCHARGE MOWERS ONLY (Model 102)

This section is for side discharge models only. If your mower is a top discharge model (with grass bag), proceed to the next section.

1. Attach the chute deflector by first placing it over the rear bolt in the side of the deck, then over the front bolt and sliding it into position, with shoulder bolt on deck in notch on deflector.

2. Secure the front of the deflector to the bolt protruding from the deck with one flat washer (I) and wing nut (J). See figure 12.

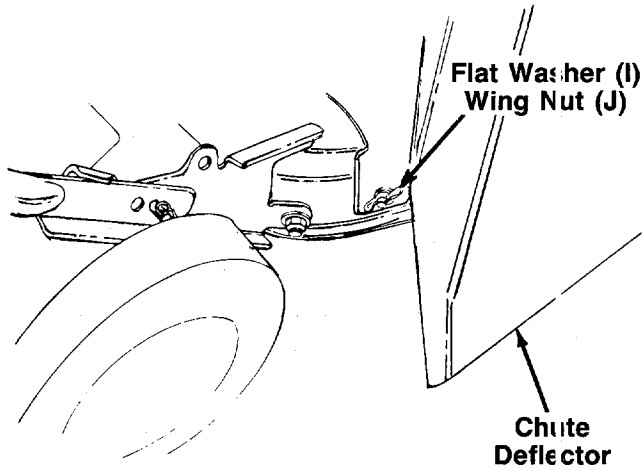

FIGURE 13.

- Secure the back of the deflector in the same manner. See figure 13.



WARNING

Never operate your unit without either the side chute deflector or entire top discharge chute and catcher panel assembly (optional equipment) in place.

- If plastic plug is not already assembled, insert plastic plug (K) into hole in the top rear of the deck by slipping one end of plug into hole, then pressing down on the other end of plug.
- Check all nuts and bolts for correct tightness.



NOTE

A grass catcher kit is available which will convert your mower from side to top discharge. Order model number 196-067-000.

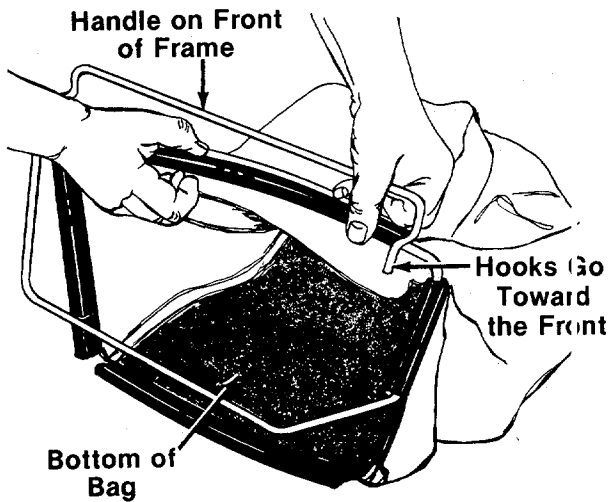

FIGURE 14.

TOP DISCHARGE MOWERS ONLY (Model 112)

Grass Catcher Assembly

- Place bag over frame (black plastic side is the bottom of bag). Handle on frame goes to the top of bag. Hooks go toward the front. See figure 14.
- Secure bag to frame by slipping plastic channels on bag over frame. See figure 14.

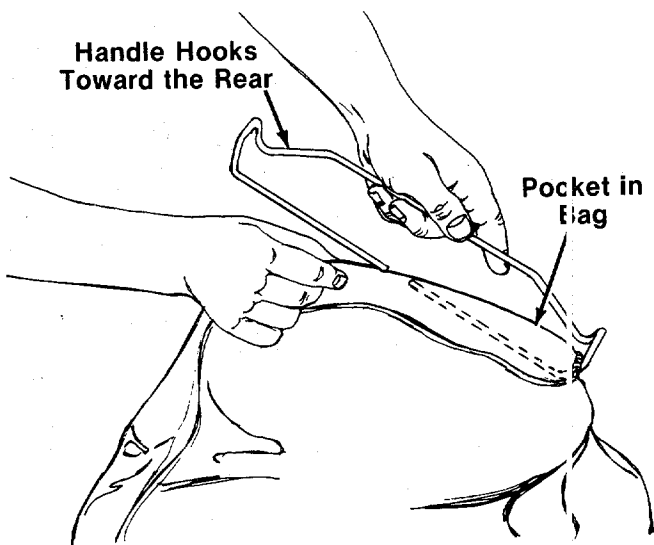

FIGURE 15.

- Attach the rear handle to bag by inserting one side of handle into pocket on the rear of the bag. The handle should hook toward the rear of the bag as shown in figure 15. Thread all the material onto one side, then slide it over onto the other side. See figure 15.

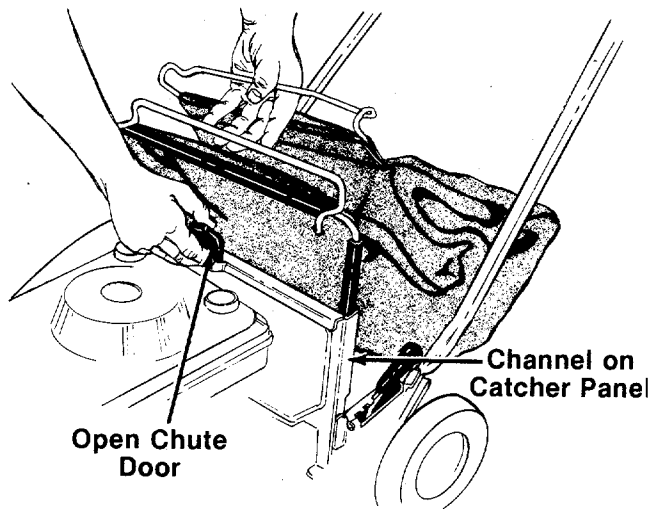

FIGURE 16.

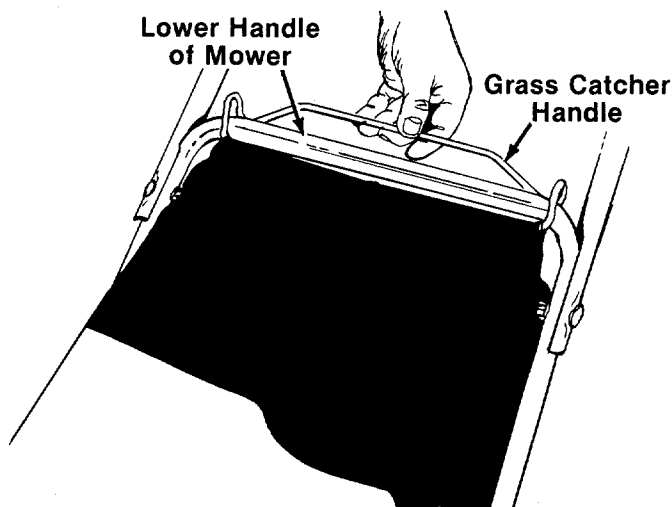

FIGURE 17.

To Attach Bag To Mower



DO NOT operate the mower with the chute door open unless the complete grass catcher is properly mounted on the mower.

1. Hold the chute door on the catcher panel open as shown in figure 16.
2. Slide the frame of the grass catcher down into the channels on the catcher panel. The hooks on the frame go over the catcher panel.
3. Hook the handle on the rear of the grass catcher over the lower handle of the mower. See figure 17.

To remove the grass catcher, unhook the rear handle and lift the grass catcher straight up.

To convert your mower back to a side discharge unit, remove only the grass bag and top discharge chute, and assemble the side chute deflector. It is not necessary to remove the catcher panel and brackets.

If your unit is not equipped with a side deflector, one is available. Order model number 196-068-000.



Never operate your unit without either the side chute deflector or entire top discharge chute and catcher panel assembly in place.

CONTROLS

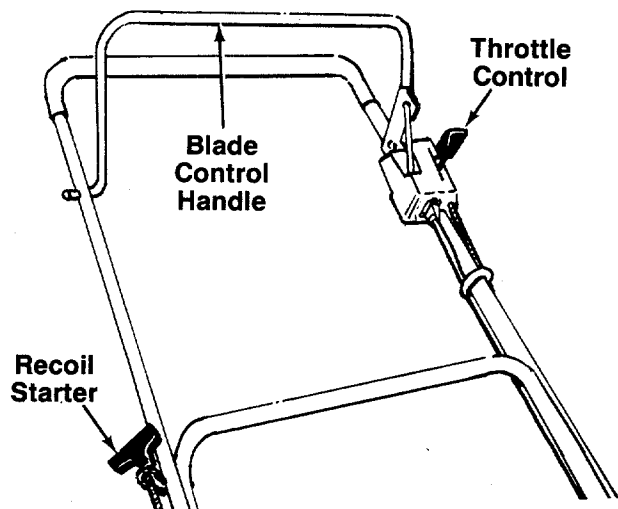

FIGURE 18.

BLADE CONTROL HANDLE

WARNING
THIS CONTROL MECHANISM IS A SAFETY DEVICE. NEVER ATTEMPT TO BYPASS ITS OPERATIONS

The blade control handle is located on the upper handle of the mower. See figure 18. The blade control handle must be depressed in order to operate the unit. Release the blade control handle to stop the engine and blade.



The blade will be rotating whenever the engine is running.

THROTTLE CONTROL

The throttle control is located on the left side of the upper handle. It is used to regulate the engine speed. The engine should be started with the engine in the CHOKE position.



The throttle control cannot be used to stop the engine.

RECOIL STARTER

The recoil starter handle is attached to the handle. See figure 18. Stand behind the unit in the operating position to start the unit.

OPERATION



FIGURE 19.

Keep hands and feet away from the chute area on cutting deck. See figure 19.



For shipping purposes your mower is set with the wheels in a low cutting height position. For best results raise the cutting position until it is determined which height is best for your lawn. See cutting height adjustment section.

BEFORE STARTING

1. Fill sump with oil as instructed in the separate engine manual packed with your unit.
2. Fill fuel tank, using clean, fresh, unleaded, low-lead or regular grade leaded gasoline. Fill tank completely!

DO NOT MIX OIL WITH GASOLINE.

3. Attach spark plug wire to spark plug.
4. The fuel shut-off valve is located beneath the fuel tank. On Model 112, an access hole is provided in the catcher panel. The fuel shut-off valve should be in the open position. See figure 20. Open fuel shut-off valve using a wrench if it is closed. See figure 21.

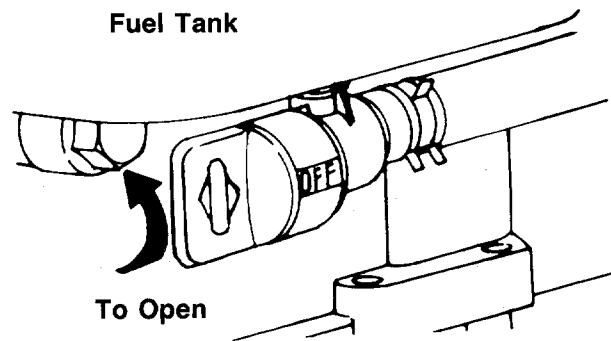

FIGURE 20.

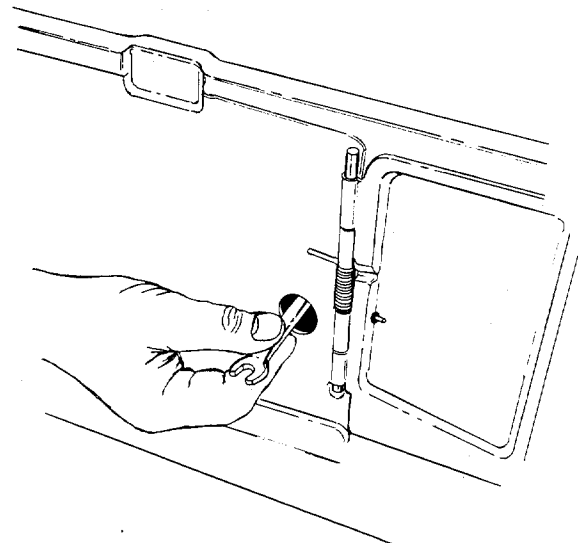

FIGURE 21.

TO START ENGINE AND ENGAGE BLADE

1. Move the throttle control lever to CHOKE position.



A warm engine may not require choking.

2. Standing behind the unit, depress the blade control handle and hold it against the upper handle as shown in figure 22.
3. Grasp the recoil starter handle as shown and pull back rapidly, extending rope fully. Return it slowly to the rope guide bolt.
4. After engine starts, move throttle control to FAST or desired engine speed.

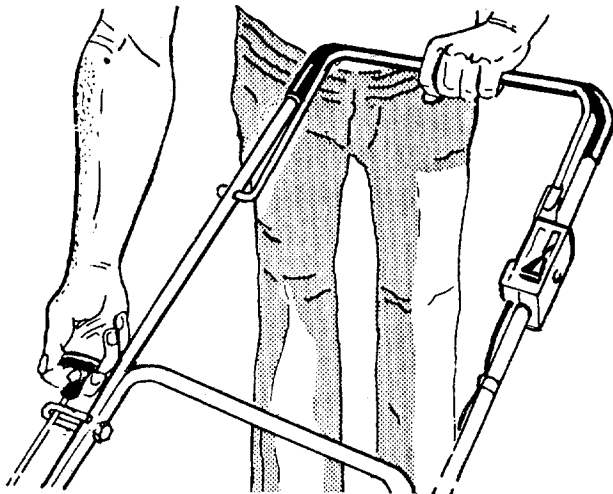

FIGURE 22.



WARNING

Never operate your unit without either the side chute deflector or entire top discharge chute and catcher panel assembly in place.

TO STOP ENGINE AND BLADE

1. Release the blade control handle to stop the engine and blade.



WARNING

The blade continues to rotate for a few seconds after the engine is shut off.

2. Disconnect the spark plug wire and ground it against the engine to prevent accidental starting while equipment is unattended.

USING YOUR ROTARY MOWER



WARNING

DO NOT operate mower Model 112 with the chute door open unless the complete grass catcher is properly mounted on the mower.

Be sure that lawn is clear of stones, sticks, wire, or other objects which could damage lawn mower or engine. Such objects could be accidentally thrown by the mower in any direction and cause serious personal injury to the operator and others.

Operate a new engine at intermediate speeds and light load for the first few hours as you would a new automotive engine.

For the best results, do not cut wet grass because it tends to stick to the underside of the mower, preventing proper discharge of grass clippings, and could cause you to slip and fall. New grass, thick grass or wet grass may require a narrower cut. Blade speed should be adjusted to the condition of the lawn.

When using the side discharge mower, the best mowing pattern is one that allows the clippings to discharge towards the uncut part of the lawn. This permits re-cutting of the clippings to further pulverize them. When cutting high weeds, discharge towards cut portion, then recut at right angles to first direction.

For best results, cut off one-third or less of the total length of the grass. Lawn should be cut in the fall as long as there is growth.

This mower is designed to be operated at full throttle to give you the best cut and do the most effective job of bagging the cut grass.



IMPORTANT

If you strike a foreign object, stop the engine. Remove wire from spark plug, thoroughly inspect the mower for any damage, and repair the damage before restarting and operating the mower. Extensive vibration of the mower during operation is an indication of damage. The unit should be promptly inspected and repaired.

ADJUSTMENTS



WARNING

Do not at any time make any adjustment to lawn mower without first stopping engine and disconnecting spark plug wire.

CUTTING HEIGHT ADJUSTMENT

The height adjustment handle is located on the left side of the deck. The handle may be placed in one of nine cutting height positions. Push the handle to the left and then either forward to lower the cutting height or backward to raise the cutting height. See figure 23.

For rough or uneven lawns, move the height adjustment handle to a position which will give a higher cutting height.

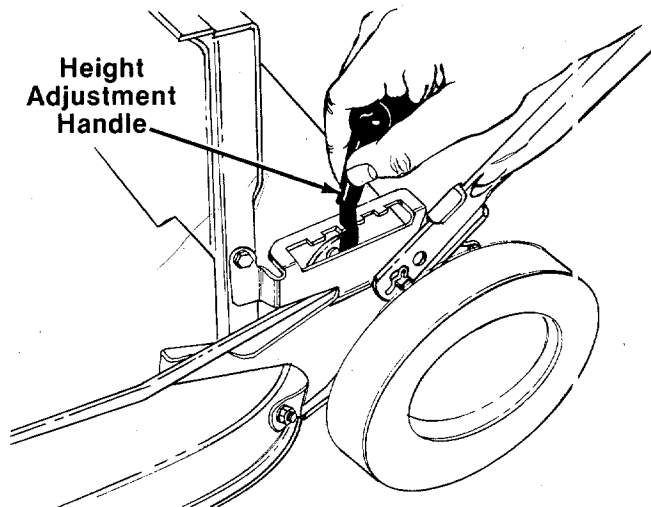

FIGURE 23.

THROTTLE

The throttle control wire assembly can be adjusted if necessary. Refer to steps 8 thru 12 of assembly instructions.

CARBURETOR ADJUSTMENTS



WARNING

If any adjustments are made to the engine while the engine is running (e.g. carburetor), keep clear of all moving parts. Be careful of heated surfaces and muffler.

Minor carburetor adjustment may be required to compensate for differences in fuel, temperature, altitude and load.

Refer to the separate engine manual packed with your mower for carburetor adjustment information.

LUBRICATION



WARNING

Always stop engine and disconnect spark plug wire before cleaning, lubricating or doing any kind of work on lawn mower.

Blade Control—Lubricate the pivot points on the blade control handle and the brake cable at least once a season with light oil. See figure 24. The blade control must operate freely in both directions.

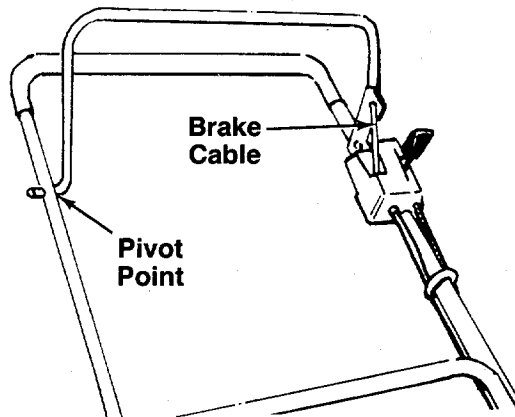

FIGURE 24.

Discharge Chute Door Mechanism (Model 112)—

The torsion spring and pivot point should be lubricated periodically with light oil to prevent any rust or binding. Door must work freely.

Wheels—Mower may be provided with ball bearing wheels. Lubricate at least once a season with light oil. Also, if the wheels are removed for any reason, lubricate the surface of the axle bolt and the inner surface of the wheel with light oil. A 4 oz. plastic bottle of light oil lubricant is available. Order part number 737-0170. Engine oil may also be used.

Engine—Follow engine manual for lubrication instructions.

Throttle—Periodically lubricate throttle control lever and throttle wire assembly with a few drops of light oil for ease of operation.

MAINTENANCE



NOTE

When tipping the unit, empty the fuel tank and keep engine spark plug side up.

CUTTING BLADE

A. Removal for Sharpening or Replacement



WARNING

Be sure to disconnect and ground the spark plug wire before working on the cutting blade to prevent accidental engine starting. Protect hands by using heavy gloves or a rag to grasp the cutting blade.

Remove the large bolt and lock washer which holds the blade and adapter to the engine crankshaft. Remove the blade and adapter from the crankshaft.

If the blade or blade adapter needs replacing, remove the two small bolts, lock washers and nuts which hold the blade to the adapter.



CAUTION

Periodically inspect the blade adapter for cracks, especially if you strike a foreign object. Replace when necessary.

B. Sharpening

Remove the cutting blade by following the directions of the preceding section.

When sharpening the blade, follow the original angle of grind as a guide. It is **extremely important** that each cutting edge receives an equal amount of grinding to prevent an unbalanced blade. An unbalanced blade will cause excessive vibration when rotating at high speeds, may cause damage to the mower and could break, causing personal injury.

It is recommended that the blade always be removed from the adapter for the best test of balance. The blade can be tested by balancing it on a round shaft screwdriver. Remove metal from the heavy side until it balances evenly.

C. Reassembly

Before reassembling the blade and the blade adapter to the unit, lubricate the engine crankshaft and the inner surface of the blade adapter with light oil. Lubricating the bolt holes, bolts and inner surface of the nuts with light oil is also recommended. A 4 oz. plastic bottle of light oil lubricant is available. Order part number 737-0170. Engine oil may also be used.

When replacing the blade, be sure to install the blade with the side of the blade marked "Bottom" (or with part number) facing the ground when the mower is in the operating position.

Blade Mounting Torque

3/8" Dia. Bolt 375 in. lb. min., 450 in. lb. max.

5/16" Dia. Bolt 150 in. lb. min., 250 in. lb. max.

To insure safe operation of your unit, **all** nuts and bolts must be checked periodically for correct tightness.

DECK

The underside of mower deck should be cleaned after each period of use as grass clippings, leaves, dirt and other matter will accumulate. This accumulation of grass clippings, etc., is undesirable as it will invite rust and corrosion and may cause an uneven discharge of grass clippings at the next cutting.

The deck may be cleaned by tilting the mower forward or on its side and scraping clean with a suitable tool or by washing with a stream of water from a garden hose.



NOTE

Do not direct the stream of water at a hot engine as damage to the engine may result.

ENGINE OIL

Check oil level before starting engine and after every 5 hours of operation. **ADD** oil as necessary to keep level to full mark on dipstick. Before removing dipstick, clean area around dipstick to prevent dirt from entering oil fill tube. Engine should be in a level position when checking oil.

Change oil after first 5 hours of operation. Thereafter change every 25 hours. Change oil while engine is warm. Oil may be drained thru oil drain on bottom of the engine. Oil capacity 1-1/4 pints.

AIR CLEANER

Service air cleaner every 25 hours under normal conditions. Clean every few hours under extremely dusty conditions. Poor engine performance and flooding usually indicates that the air cleaner should be serviced.

To service the air cleaner, refer to the separate engine manual packed with your unit.

SPARK PLUG

The spark plug should be cleaned and the gap reset once a season. Spark plug replacement is recommended at the start of each mowing season; check engine manual for correct plug type and gap specifications.

OFF-SEASON STORAGE

The following steps should be taken to prepare lawn mower for storage.

1. Clean and lubricate mower thoroughly as described in the lubrication instructions.
2. Refer to engine manual for correct engine storage instructions.
3. Coat mower's cutting blade with chassis grease to prevent rusting.
4. Store mower in a dry, clean area.



NOTE

When storing any type of power equipment in an unventilated or metal storage shed, care should be taken to rustproof the equipment. Using a light oil or silicone, coat the equipment, especially cables and all moving parts.

 **NOTE**

The use of any accessory on this Rotary Mower other than those manufactured by the mower manufacturer is **not** recommended.

GRASS CATCHER Model 067 is available as replacement equipment for the mower Model 112 shown in this manual.



WARNING

1. DO NOT operate the mower with the chute door open unless the complete grass catcher is properly mounted on the mower.
2. DO NOT operate the mower without the protective shield on the rear of the deck in place.

 **NOTE**

Under normal usage bag material is subject to wear and should be checked periodically. Be sure any replacement bag complies with the mower manufacturer's recommendations.

For replacement bags, use only factory authorized replacement bag No. 764-0212.

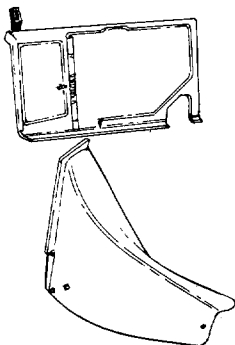

Model 067

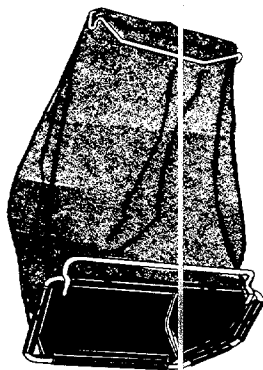

Model 068

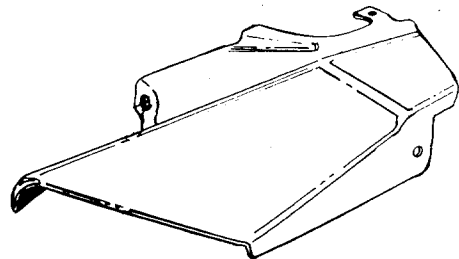

For units not equipped with the above, top discharge grass bag assembly Model 196-067-000 and side chute deflector Model 196-068-000 are available as optional equipment.

Trouble Shooting Chart

Problem	Cause	Remedy
1 Engine fails to start	A Blade control handle disengaged B Check fuel tank for gas C Fuel shut-off valve closed D Spark plug lead wire disconnected. E Throttle control lever not in the starting position F Faulty spark plug G Carburetor improperly adjusted, engine flooded H Old stale gasoline I Engine brake engaged	A Engage blade control handle. B Fill tank if empty. C Open fuel shut-off valve. D Connect lead wire. E Move throttle lever to start position. F Spark should jump gap between control electrode and side electrode. If spark does not jump, replace the spark plug. G Remove spark plug, dry the plug, crank engine with plug removed, and throttle in off position. Replace spark plug and lead wire and resume starting procedures. H Drain and refill with fresh gasoline. I Follow starting procedure.
2 Hard starting or loss of power	A Spark plug wire loose B Carburetor improperly adjusted C Dirty air cleaner	A Connect and tighten spark plug wire. B Adjust carburetor. See separate engine manual. C Clean air cleaner as described in separate engine manual.
3 Operation erratic	A Dirt in gas tank B Dirty air cleaner C Water in fuel supply D Vent in gas cap plugged E Carburetor improperly adjusted	A Remove the dirt and fill tank with fresh gas. B Clean air cleaner as described in separate engine manual. C Drain contaminated fuel and fill tank with fresh gas. D Clear vent or replace gas cap. E Adjust carburetor. See separate engine manual.
4 Occasional skip (hesitates) at high speed	A Carburetor idle speed too slow B Spark plug gap too close C Carburetor idle mixture adjustment improperly set	A Adjust carburetor. See separate engine manual. B Adjust to .030". C Adjust carburetor. See separate engine manual.
5 Idles poorly	A Spark plug fouled, faulty, or gap too wide B Carburetor improperly adjusted C Dirty air cleaner	A Reset gap to .030" or replace spark plug. B Adjust carburetor. See separate engine manual. C Clean air cleaner as described in separate engine manual.
6 Engine overheats	A Carburetor not adjusted properly B Air flow restricted C Engine oil level low	A Adjust carburetor. See separate engine manual. B Remove blower housing and clean as described in separate engine manual. C Fill crankcase with the proper oil.
7 Excessive vibration	A Cutting blade loose or unbalanced B Bent cutting blade	A Tighten blade and adapter. Balance blade. B Replace blade.

Note: For repairs beyond the minor adjustments listed above, contact your local authorized service dealer.

Models 102 and 112

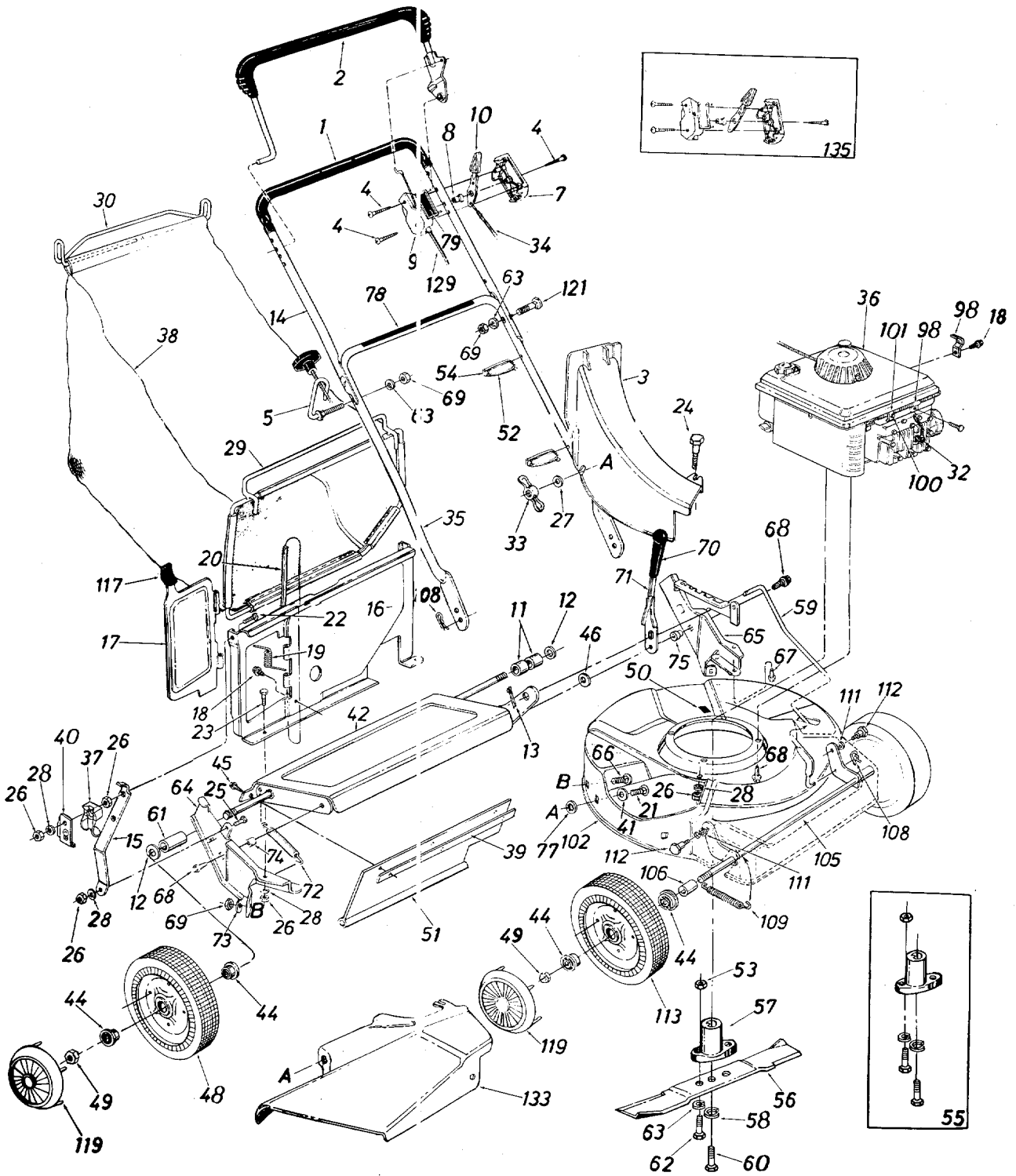

PARTS LIST FOR MODEL 112 ROTARY MOWER

REF. NO.	PART NO.	COLOR CODE	DESCRIPTION	NEW PART	REF. NO.	PART NO.	COLOR CODE	DESCRIPTION	NEW PART
1	718-0145		Grip		55	753-0348		Blade Adapter Kit	
2	14321		Control Handle Ass'y.—L.H.		56	742-0289		21" Blade	
3	731-0733		Top Discharge Chute Ass'y.†		57	719-0262		Blade Adapter	
4	710-0796		Truss Mach. Scr. #12 x 1.50" Lg.		58	736-0217		L-Wash. 3/8" I.D.—H.D.	
5	710-0842		Rope Guide Bolt		59	747-0496		Height Adj. Rod. 19.42" Lg.	
7	731-0817		Control Panel Half	N	60	710-0331		Hex Bolt 3/8-24 x 2.25" Lg. (Grade 5)	
8	731-0524		Control Disc Pin		61	711-0313		Sleeve .526" I.D. x .69" O.D. x .800" Lg.	
9	731-0816		Clutch Panel Half	N	62	710-0888		Hex Bolt 5/16-24 x 1.00" Lg. (Grade 5)	
10	731-0528		Throttle Control Lever		63	736-0119		L-Wash. 5/16" I.D.*	
11	711-0500		Spacer .526" I.D. x .690" O.D. x .640" Lg.		64	16136		R.H. Handle Wheel Brkt. Ass'y.	
12	736-0108		Fl-Wash. .510" I.D. x .75"		65	16137		L.H. Handle Wheel Brkt. Ass'y.	
13	714-0507		Cotter Pin 3/32" Dia. x .75"*		66	710-0260		Carriage Bolt 5/16-18 x .62"*	
14	749-0436		Upper Handle—Chrome		67	710-0603		Hex Wash. Hd. B-Tap Scr. 5/16-18	
15	16541		Panel Support Brkt.†	N	68	710-0654		Hex Wash. Hd. TT-Tap Scr. 3/8-16	
16	16140		Top Catcher Panel†		69	712-0267		Hex Nut 5/16-18 Thd.*	
17	16145		Top Door†		70	720-0143		Grip	
18	710-0429		Hex B-Tap Scr. #10 x .38"		71	732-0473		Height Adj. Lever	
19	732-0483		Torsion Spring†		72	732-0481		Extension Spring .50" O.D. x 3.80" Lg.	
20	747-0514		Pivot Pin†		74	750-0526		Spacer .385" I.D. x .502" O.D. x .270" Lg.	
21	710-0134		Carriage Bolt 1/4-20 x .62"*		75	750-0624		Shld. Spacer .500" Dia. x .100	
22	710-0166		Truss Mach. Scr. 1/4-20 x 1.0" Lg.†		77	726-0233		Bolt Retainer 1/4 x .50" O.D.	
23	710-0289		Hex Bolt 1/4-20 x .50" Lg.		78	777-5776		Instruction Label	N
24	738-0704		Shoulder Bolt .312 Dia. x .18 Lg. Special	N	79	777-5773		Control Label	N
25	710-0258		Hex Bolt 1/4-20 x .62" Lg.*		98	12894		Casing Clamp	
26	712-0287		Hex Nut 1/4-20 Thd.*		100	710-0436		Hex B-Tap Scr. #10 x .62"	
27	736-0463		Fl-Wash. .280" I.D. x .620"		101	751-0442		Casing Clamp	N
28	736-0329		L-Wash. 1/4" I.D.*		102	16125	462	21" Deck Ass'y.	
29	747-0494		Front Grass Catcher Frame†		105	10662		Front Axle Ass'y.	
30	747-0495		Grass Catcher Handle†		106	711-0313		Sleeve .526" I.D. x .690" O.D. x .880" Lg.	
32	735-0639		Spark Plug Insulator		108	714-0104		Intern. Cotter Pin 5/16" Dia.	
33	712-0109		Wing Nut		109	732-0482		Extension Spring .50" O.D. x 3.20" Lg.	
34	746-0633		Throttle Control Wire 58"	N	111	736-0221		Intern. L-Wash. 3/8 I.D.*	
35	749-0505		Lower Handle—Chrome		112	738-0615		Shld. Bolt .623" Dia. x .425	
36	—		Engine		113	734-0922		Front-Wheel Ass'y. Comp. 7 x 1.50	
37	751-0434		Rope Guide Half†		117	720-0208		Door Gript	
38	764-0212		21" Top Discharge Grass Bag†		119	731-0354		Hub Cap—Plastic—Black	
39	14835		Retaining Strip		121	710-0671		Curved Carr. Bolt 5/16-18 x 1.38" Lg.	
40	732-0528		Rope Retainer Spring Clipt	N	129	746-0477		Control Cable—43" Lg.	
41	736-0204		Fl-Wash. .344" I.D. x .62"		133	16559-462		Side Chute Deflector Ass'y.	N
42	16131		Rear Axle Ass'y.		135	753-0360		Kit—Control Housing Comp.	
44	741-0180		Flange Ball Bearing 1/2" I.D.		—	8112-000-6		Hardware Pack	
45	710-0776		Hex AB-Tap Scr. 1/4 x .62"						
46	736-0258		Fl-Wash. .38" I.D. x 1.0"						
48	734-0924		Rear Wheel Ass'y.—Comp. 8 x 1.75						
49	712-0346		Hex L-Nut 1/2-20 Thd.						
50	731-0564		Plug						
51	731-0671		Rear Flap 3.75" x 17.30" Lg.						
52	725-0157		Cable Tie						
53	712-0123		Hex Nut 5/16-24 Thd.*						
54	726-0241		Cable Anchor	N					

*For faster service obtain standard nuts, bolts and washers locally. If these items cannot be obtained locally, order by part number and size as shown on parts list.

†Top Discharge Model 112 Only.

NOTE: Specifications subject to change without notice or obligation.

PARTS INFORMATION

POWER EQUIPMENT PARTS AND SERVICE

Parts and service are available through the authorized service firms listed below. All orders should specify the model number of your unit, part numbers, description of parts and the quantity of each part required.

BRIGGS AND STRATTON, TECUMSEH AND PEERLESS PARTS AND SERVICE

Briggs & Stratton, Tecumseh and Peerless parts and service should be handled by your nearest authorized engine service firm. Check the yellow pages of your telephone directory under the listing **Engines—Gasoline**, Briggs & Stratton or Tecumseh Lauson.

NOTE: If any parts are found to be missing or defective upon assembly of this unit, write to advise the factory so that immediate replacement can be made.

ALABAMA	BIRMINGHAM		GOLDSBORO
Auto Electric & Carburetor Co.	2625 4th Ave. S.	35233	515 N. George St.
ARKANSAS	NORTH LITTLE ROCK		GREENSBORO
Sutton's Lawn Mower Shop	5301 Roundtop Drive		335 N. Green
	Box 368, Rt. 4	72117	CARROLL
CALIFORNIA	PORTERVILLE		CLEVELAND
Billious	75 North D Street	93257	7900 Lorain Ave.
COLORADO	DENVER		WADSWORTH
Spitzer Industrial Products Co.	6601 N.		687 Seville Rd.
	Washington St.	80229	YOUNGSTOWN
FLORIDA	JACKSONVILLE		1301 Logan Ave.
Radco Distributors	4909 Victor St.		Box 929
	Box 5459	32207	MUSKOGEE
	HIALEAH		605 S. Cherokee
Small Eng. Dist.	7995 W. 26th Court	33016	PORTLAND
GEORGIA	EAST POINT		Keaton Supply Co.
East Point Cycle & Key Inc.	2834 Church St.	30344	PENNSYLVANIA
ILLINOIS	LYONS		HARRISBURG
Keen Edge Co.	8615 Ogden Ave.	60534	4021 N. 6th St.
INDIANA	ELKHART		WILLOW GROVE
Parts & Sales Inc.	2101 Industrial Pkwy.	46516	Thompson Rubber Co.
IOWA	DUBUQUE		850 Davisville Rd.
Power Lawn & Garden Equip.	2551 J.F. Kennedy	52001	PITTSBURGH
LOUISIANA	NEW ORLEANS		Bluemont Co.
Suhren Engine Co.	8330 Earhart Blvd.	70118	11125 Frankstown Rd.
MARYLAND	TAKOMA PARK		PUNXSUTAWNEY
Center Supply Co.	6867 New Hampshire		R.D. 2
	Ave.	20912	SCRANTON
MASSACHUSETTS	SPRINGFIELD		Scranton Auto Ignition Co.
Morton B. Collins Co.	300 Birnie Ave.	01107	1133-35 Wyoming Ave.
MICHIGAN	LANSING		TENNESSEE
Lorenz Service Co.	2500 S. Pennsylvania	48910	Ace Distributors
	MOUNT CLEMENS		2103 Magnolia
Power Equipment Dist.	340 Hubbard	48043	MEMPHIS
MINNESOTA	HOPKINS		American Sales & Service, Inc.
Hance Distributing Inc.	420 Excelsior Ave. W.	55343	3035-43 Bellbrook
MISSOURI	KANSAS CITY		TEXAS
Automotive Equip. Service	3117 Holmes St.	64109	Marr Brothers, Inc.
	ST. JOSEPH		423 E. Jefferson
Ross-Frazier Supply Co.	8th and Monterey	64503	FORT WORTH
	ST. LOUIS		733 Baker Blvd.
Henzler, Inc.	2015 Lemay Ferry Rd.	63125	Hwy. 10
NEW JERSEY	BELLMAWR		HOUSTON
Lawnmower Parts Inc.	717 Creek Rd.	08030	2409 Commerce St.
NEW MEXICO	ALBUQUERQUE		SAN ANTONIO
Spitzer Eng. & Parts Co.	1023 Third Ave. N.W.	87103	8610 Botts Lane
NEW YORK	CARTHAGE		P.O. Box 17867
Gamble Dist., Inc.	West End Ave.	13619	SALT LAKE CITY
			1661 N. Beck St.
			ASHLAND
			101 Cedar Ridge Dr.
			WASHINGTON
			SEATTLE
			Equip. Northwest
			1410 14th Ave.
			WISCONSIN
			MILWAUKEE
			Wisconsin Magneto Inc.
			4727 N. Teutonia St.
			53209

WARRANTY PARTS AND SERVICE POLICY

(0685)

The purpose of warranty is to protect the customer from defects in workmanship and materials, defects which are NOT detected at the time of manufacture. It does not provide for the unlimited and unrestricted replacement of parts. Use and maintenance are the responsibility of the customer. The manufacturer cannot assume responsibility for conditions over which it has no control. Simply put, if it's the manufacturer's fault, it's the manufacturer's responsibility; if it's the customer's fault, it's the customer's responsibility.

CLAIMS AGAINST THE MANUFACTURER'S WARRANTY INCLUDES:

1. Replacement of Missing Parts on new equipment.
2. Replacement of Defective Parts within the warranty period.
3. Repair of Defects within the warranty period.

All claims MUST be substantiated with the following information:

1. Model Number of unit involved.
2. Date unit was purchased or first put into service.
3. Date of failure.
4. Nature of failure.