

OWNER'S GUIDE

OUTDOOR POWER EQUIPMENT
for all seasons

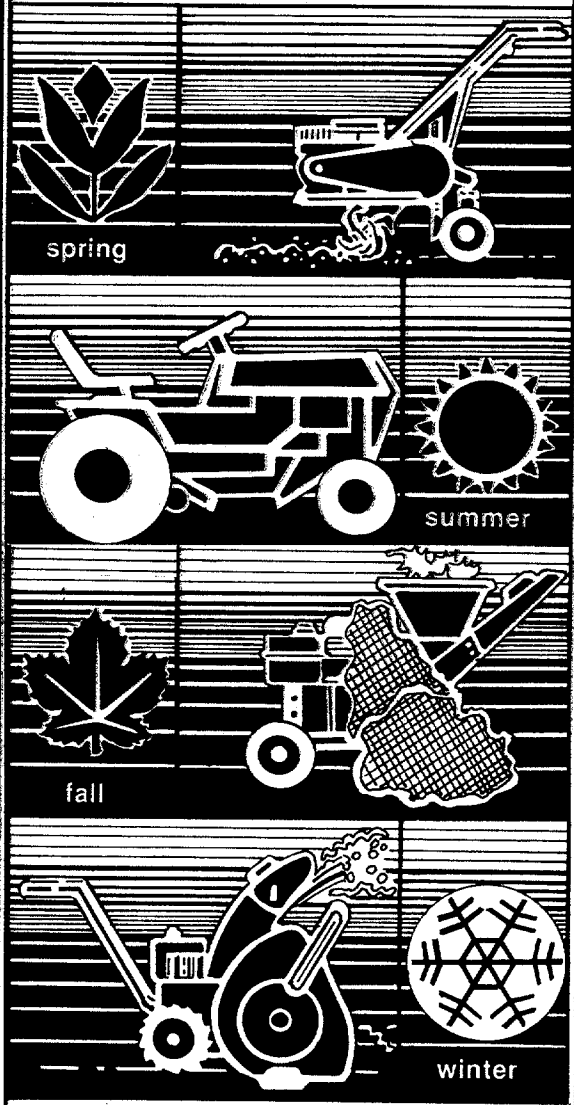

22" Hi-Wheel Rotary Mower

Model Number 115-533-000

Important:
**Read Safety Rules and
Instructions Carefully**

Thank you for purchasing
an American-built product.

INDEX

| | | | |
|--------------------------------|---|------------------------------|------------|
| Safe Operation Practices | 3 | Maintenance | 9 |
| Assembly Instructions | 4 | Off-Season Storage | 11 |
| Controls | 6 | Trouble Shooting Chart | 13 |
| Operation | 7 | Illustrated Parts | 14, 16 |
| Adjustments | 8 | Repair Parts Lists | 15, 17 |
| Lubrication | 9 | Parts Information | Back Cover |



Instructions given with this symbol are for personal safety. Be sure to follow them.

LIMITED WARRANTY

For one year from the date of original retail purchase, MTD PRODUCTS INC will either repair or replace, at its option, free of charge, F.O.B. factory or authorized service firm, any part or parts found to be defective in material or workmanship. Transportation charges for the movement of any power equipment unit or attachment are the responsibility of the purchaser. Transportation charges for any parts submitted for replacement under this warranty must be paid by the purchaser unless such return is requested by MTD PRODUCTS INC.

This warranty will not apply to any part which has become inoperative due to misuse, excessive use, accident, neglect, improper maintenance, alterations, or unless the unit has been operated and maintained in accordance with the instructions furnished. This warranty does not apply to the engine, motor, battery, battery charger or component parts thereof. Please refer to the applicable manufacturer's warranty on these items.

This warranty will not apply where the unit has been used commercially.

Warranty service is available through your local authorized service dealer or distributor. If you do not know the dealer or distributor in your area, please write to the Customer Service Department of MTD.

The return of a complete unit will not be accepted by the factory unless prior written permission has been extended by MTD.

This warranty gives you specific legal rights. You may also have other rights which vary from state to state.



WARNING

This unit is equipped with an internal combustion engine and should not be used on or near any unimproved forest-covered, brush-covered or grass-covered land unless the engine's exhaust system is equipped with a spark arrester meeting applicable local or state laws (if any). If a spark arrester is used, it should be maintained in effective working order by the operator.

In the State of California the above is required by law (Section 4442 of the California Public Resources Code). Other states may have similar laws. Federal laws apply on federal lands. A spark arrester muffler is available at your nearest engine authorized service center.



WARNING

To reduce the potential for any injury, comply with the following safety instructions. Failure to comply with the instructions may result in personal injury.

SAFE OPERATION PRACTICES FOR WALK-BEHIND MOWERS

TRAINING

1. Read this owner's manual carefully in its entirety before attempting to assemble or operate this machine. Be completely familiar with the controls and the proper use of this machine before operating it. Keep this manual in a safe place for future and regular reference and for ordering replacement parts.
2. Your rotary mower is a precision piece of power equipment, not a plaything. Therefore, exercise extreme caution at all times.
3. Never allow children to operate a power mower. Only persons well acquainted with these rules of safe operation should be allowed to use your mower.
4. No one should operate this unit while intoxicated or while taking medication that impairs the senses or reactions.
5. Keep the area of operation clear of all persons, particularly small children and pets. Stop engine when they are in the vicinity of your mower. Although the area of operation should be completely cleared of foreign objects, an object may have been overlooked and could be accidentally thrown by the mower in any direction and cause serious personal injury to the operator or any others allowed in the area.

PREPARATION

1. Thoroughly inspect the area where the equipment is to be used. Remove all stones, sticks, wire, bones and other foreign objects which could be picked up and thrown by the mower in any direction and cause serious personal injury to the operator or any others allowed in the area.
2. Do not operate equipment when barefoot or wearing open sandals. Always wear substantial footwear.
3. Do not wear loose fitting clothing that could get caught on the mower.
4. Check the fuel before starting the engine. Gasoline is an extremely flammable fuel. Do not fill the gasoline tank indoors, while the engine is running, or while the engine is still hot. Wipe off any spilled gasoline before starting the engine as it may cause a fire or explosion.
5. Disengage the self-propelled mechanism or drive clutch on units so equipped before starting the engine.
6. The blade control handle is a safety device. Never attempt to bypass its operation. Doing so makes the safety device inoperative and may result in personal injury through contact with the rotating blade. The blade control handle must operate easily in both directions.
7. Never attempt to make a wheel or cutting height adjustment while the engine is running.
8. Mow only in daylight or in good artificial light.
9. Never operate the equipment in wet grass. Always be sure of your footing. A slip and fall can cause

serious personal injury. Keep a firm hold on the handle and walk, never run.

OPERATION

1. Do not change the engine governor settings or overspeed the engine. Excessive engine speeds are dangerous.
2. Do not put hands or feet near or under rotating parts. Keep clear of the discharge opening at all times as the rotating blade can cause injury.
3. Stop the blade when crossing gravel drives, walks or roads.
4. After striking a foreign object, stop the engine, remove the wire from the spark plug, and thoroughly inspect the mower for any damage. Repair the damage before restarting and operating the mower.
5. If the equipment should start to vibrate abnormally, stop the engine and check immediately for the cause. Vibration is generally a warning of trouble.
6. Shut the engine off and wait until the blade comes to a complete stop before removing the grass catcher or unclogging the chute. The cutting blade continues to rotate for a few seconds after the engine is shut off. Never place any part of the body in the blade area until you are sure the blade has stopped rotating.
7. Before cleaning, repairing or inspecting, make certain the blade and all moving parts have stopped. Disconnect the spark plug wire, and keep the wire away from the spark plug to prevent accidental starting.
8. Do not run the engine indoors.
9. Mow across the face of slopes, never up-and-down. Exercise extreme caution when changing direction on slopes. Do not mow excessively steep slopes. Always be sure of your footing. A slip and fall can cause serious personal injury.
10. Always disconnect electric mowers (line operated) before cleaning, repairing or adjusting.
11. Never operate mower without proper guards, plates or other safety protective devices in place.

MAINTENANCE AND STORAGE

1. Check the blade and engine mounting bolts at frequent intervals for proper tightness.
2. Keep all nuts, bolts, and screws tight to be sure the equipment is in safe working condition.
3. Never store the equipment with gasoline in the tank inside of a building where fumes may reach an open flame or spark. Allow the engine to cool before storing in any enclosure.
4. To reduce fire hazard, keep the engine free of grass, leaves, or excessive grease.
5. Check the grass catcher bag frequently for wear or deterioration. For safety protection, replace only with new bag meeting original equipment specifications.



Reference to right or left hand side of the mower is observed from the operating position.

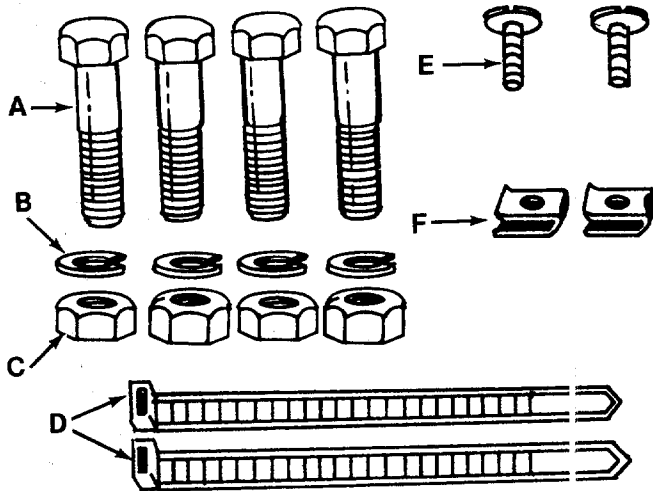

FIGURE 1.

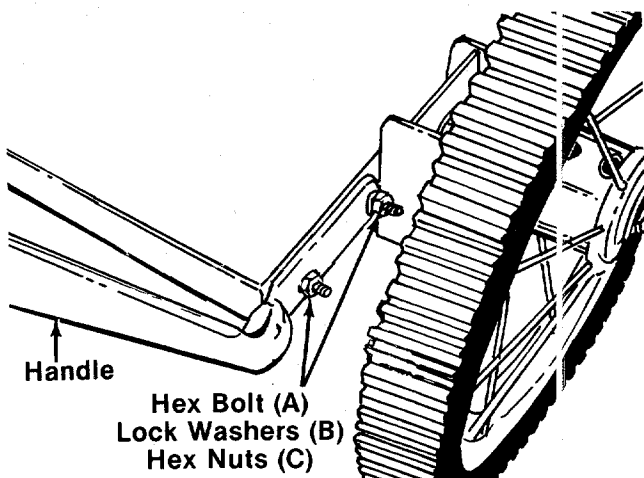

FIGURE 2.

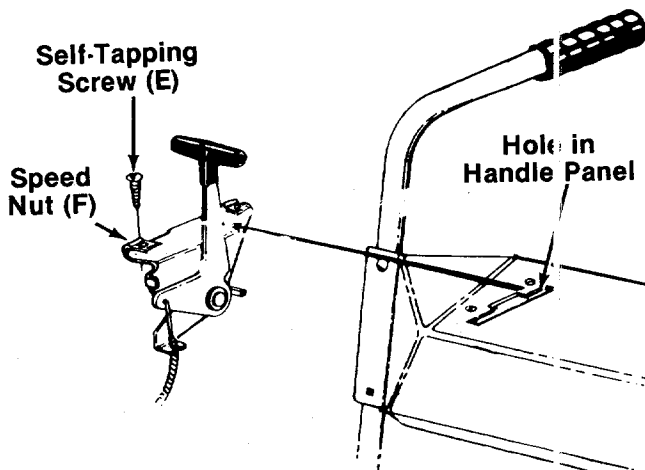

FIGURE 3.

ASSEMBLY INSTRUCTIONS



This unit is shipped WITHOUT GASOLINE or OIL. After assembly, see separate engine manual for proper fuel and engine oil recommendations.

1. Remove the lawn mower, loose parts, hardware pack and literature from the carton. Make certain all parts and literature have been removed before the carton is discarded.
2. Extend the throttle control assembly and lay on the floor. Be careful not to bend or kink control wire.

← Contents of Hardware Pack:

- A (4) Hex Bolts 5/16-24 x 1.25" Long
- B (4) Lock Washers 5/16" I.D.
- C (4) Hex Nuts 5/16-24 Thread
- D (2) Cable Ties
- E (2) Self-Tapping Screws .50" Long
- F (2) Speed Nuts
- G (4) Plastic Plugs (Not Shown)

HANDLE ASSEMBLY

1. Line up the holes in the handles with the holes in the frame. Secure with hex bolts (A), lock washers (B) and hex nuts (C). See figure 2.
2. Start all four nuts and bolts by hand, then tighten securely.
2. Tighten the carriage bolts and nuts which hold the handle panel to the handles, **except** for the upper carriage bolt on the left hand handle. Leave this bolt loose until after the blade clutch control cable is installed.

THROTTLE CONTROL INSTALLATION

Place the speed nuts (F), flat side up, onto the throttle control. Place throttle control lever up through the hole in the handle panel. Secure with self-tapping screw (E) as shown in figure 3.

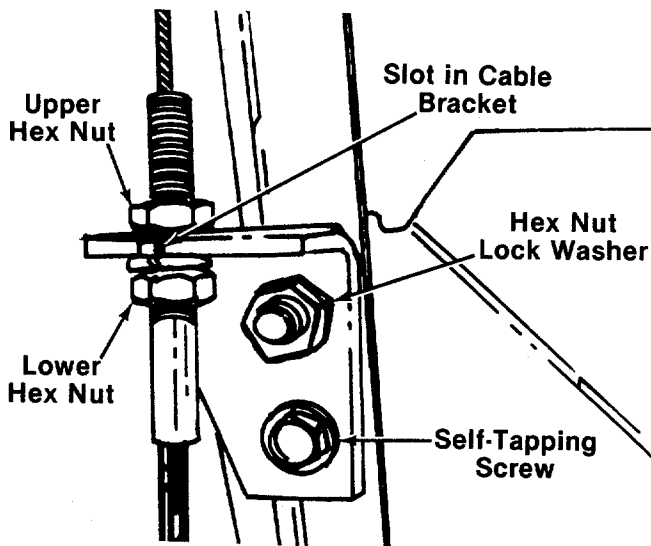

FIGURE 4.

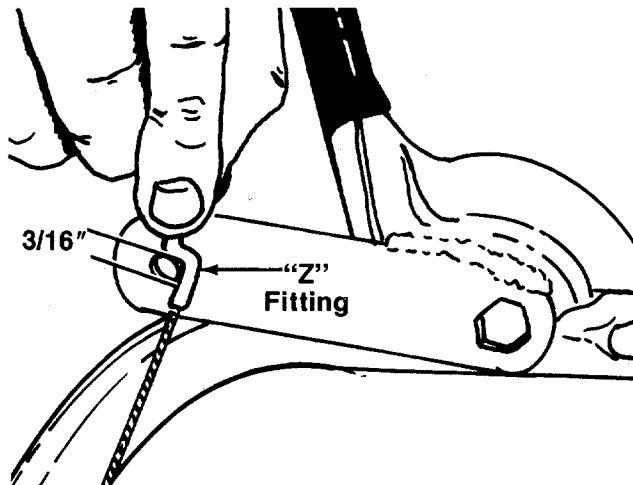

FIGURE 5.

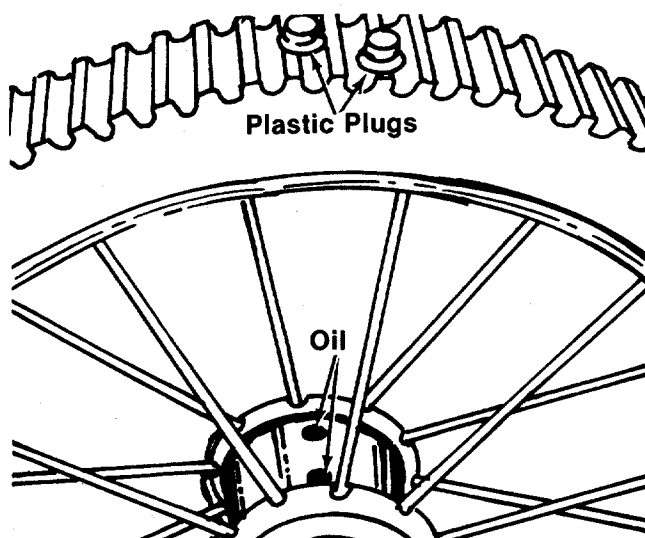

FIGURE 6.

BLADE CLUTCH CONTROL CABLE INSTALLATION

1. The blade clutch control cable is attached to the unit. Remove the hex nut from the threaded end of the clutch control cable casing, and slide the nut up the cable.
2. Slip the cable into the slot in the cable bracket, which is located behind the left hand handle. See figure 4. Slide the threaded end of the cable casing up through the bracket. Rethread the hex nut onto the end of the cable casing a few turns. See figure 4.
3. Place the clutch grip on the left handle in the raised position. Hold the "Z" end of the cable against the clutch grip as shown in figure 5. Adjust the lower hex nut (underneath the cable bracket) so that the middle of the "Z" fitting is $\frac{3}{16}$ " above the bottom of the hole on the clutch grip as shown in figure 5.
4. Tighten the upper hex nut against the cable bracket.
5. Remove the self-tapping screw from the cable bracket. Remove the hex nut and lock washer from the carriage bolt, then remove the cable bracket. See figure 4.
6. Hook the "Z" end of the cable into the hole on the clutch grip. Place the cable bracket in position on the handle so there will be **no bend or kink in the cable when the clutch grip is in the engaged position** (against the handle). Secure with hex nut, lock washer and self-tapping screw.



CAUTION

The final adjustment of the blade clutch control cable must be made before the engine is started. Final adjustment will be covered on page 6.

7. Secure cable to handle with cable ties (D). Cut off excess end of cable ties.

REAR WHEEL LUBRICATION

Add several drops of oil to the hubs of the rear wheels as shown in figure 6. Insert the plastic plugs (G) into the hubs of the rear wheels.

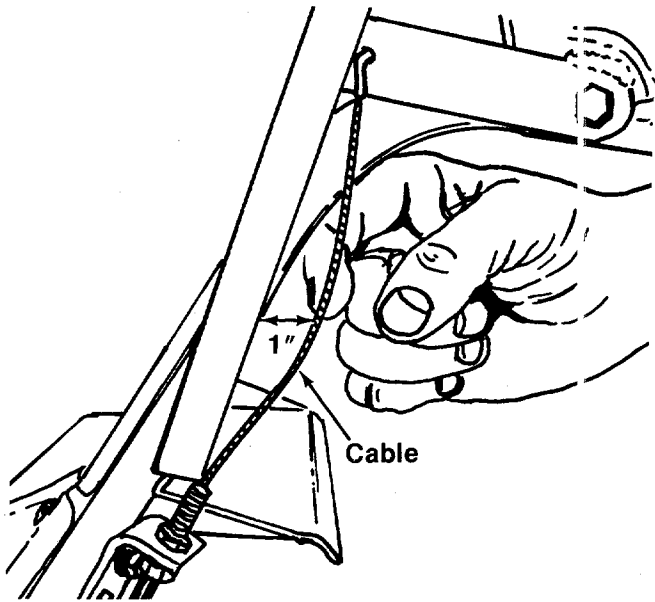

FIGURE 7.

BLADE CLUTCH FINAL ADJUSTMENT

With the clutch grip in the released (raised) position, the blade clutch control cable should have approximately 1" deflection as shown in figure 7.



There must be slack in the blade clutch cable when the clutch grip is in the released position. Periodically adjust the cable as necessary to maintain the slack.

Push the release lever to free the clutch grip, then squeeze the clutch grip against the handle. The control cable should now be straight. See figure 8.

The blade clutch adjustment may be checked as follows.

1. Disconnect the spark plug wire from the spark plug and ground it against the engine block.
2. Remove the spindle cover from the frame.
3. With the blade clutch grip released, pull the recoil starter rope several times. The belt and blade pulley on top of the deck should not turn.
4. Reassemble the spindle cover.

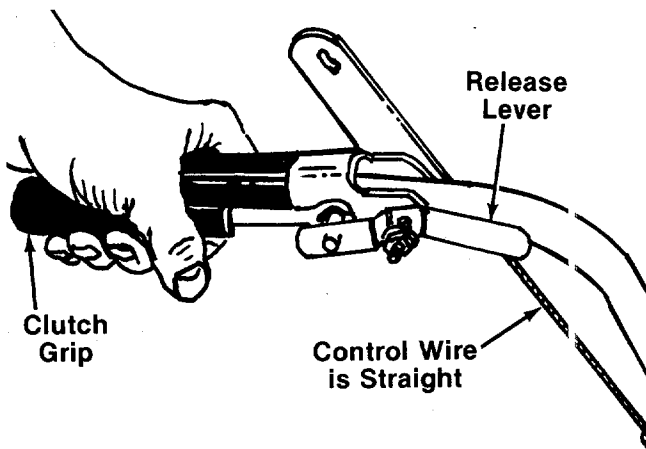

FIGURE 8.



If the belt slips when cutting heavy grass, the cable could be too loose and should be readjusted as specified.

CONTROLS

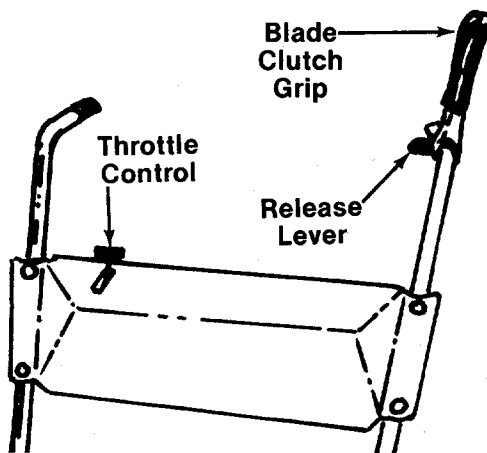

FIGURE 9.

THROTTLE CONTROL

The throttle control is located on the right hand side of handle panel. It controls engine speed. See figure 9.

BLADE CLUTCH GRIP

The blade clutch grip is located on the left handle. Push the release lever to free the blade clutch grip, then squeeze the clutch grip against the handle to engage the blade. Release the grip to stop the blade from turning. See figure 9.

OPERATION



FIGURE 10.

Keep hands and feet away from the chute area on cutting deck. See figure 10.

BEFORE STARTING

1. Check the final adjustment section of the Assembly Instructions to be sure the blade clutch control is working properly.
2. Fill sump with oil as instructed in the separate engine manual packed with your unit.
3. Fill fuel tank using clean, fresh, lead-free, low-lead, or regular grade leaded gasoline. Fill tank completely!
DO NOT MIX OIL WITH GASOLINE.

TO START ENGINE

1. Be certain the clutch grip is in the disengaged position (released). See figure 9.
2. Move the throttle control to the "CHOKE" position. See figure 9.
3. From the left side, opposite the discharge chute and with one foot on the deck, grasp the recoil starter handle and pull out rapidly. Allow the rope to rewind slowly. If the engine does not start after two or three tries, move the throttle control to the "FAST" position and try again.
4. After the engine starts, move the throttle control into the "FAST" position.

TO STOP

1. The engine is stopped by moving the throttle control lever to "STOP" position.
2. The blade is stopped by releasing the blade clutch grip, located on the left handle.
3. Disconnect spark plug wire from the spark plug and ground to prevent accidental starting while equipment is unattended.

USING YOUR ROTARY MOWER

Be sure that lawn is clear of stones, sticks, wire, or other objects which could damage lawn mower or engine. Such objects could be accidentally thrown by the mower in any direction and cause serious personal injury to the operator and others.

Appropriate clothing should be worn when cutting brush or heavy weeds. Safety shoes and safety glasses are highly recommended.

Operate a new engine at intermediate speeds and light load for the first few hours as you would a new automotive engine.

For best results, do not cut wet grass because it tends to stick to the underside of the mower, preventing proper discharge of grass clippings, and could cause you to slip and fall. New grass, thick grass or wet grass may require a narrower cut. Blade speed should be adjusted to the condition of the lawn.

The best mowing pattern is one that allows the clippings to discharge towards the uncut part of the lawn. This permits recutting of the clippings to further pulverize them. When cutting high weeds, discharge towards cut portion, then recut at right angles to first direction.

For best results, cut off one-third or less of the total length of the grass. Lawn should be cut in the fall as long as there is growth.

This mower is designed to be operated at full throttle to give you the best cut. However, unit should be run at slower speeds until operator is thoroughly familiar with controls.



IMPORTANT

If you strike a foreign object, stop the engine. Remove wire from spark plug, thoroughly inspect the mower for any damage, and repair the damage before restarting and operating the mower. Extensive vibration of the mower during operation is an indication of damage. The unit should be promptly inspected and repaired.

ADJUSTMENTS



WARNING

Do not at any time make any adjustment to lawn mower without first stopping engine and disconnecting spark plug wire.

BLADE CLUTCH ADJUSTMENT

To adjust the blade clutch, refer to the final adjustment section of the assembly instructions.

THROTTLE

If adjustment becomes necessary, the throttle control wire assembly can be reset as follows:

1. Loosen, but do not remove, screw securing throttle control wire assembly at engine. See figure 11.
2. Move throttle control lever on handle to fast position.
3. Move control lever on engine to high speed position. Retighten screw to secure throttle control wire assembly. Refer to separate engine manual for further details.

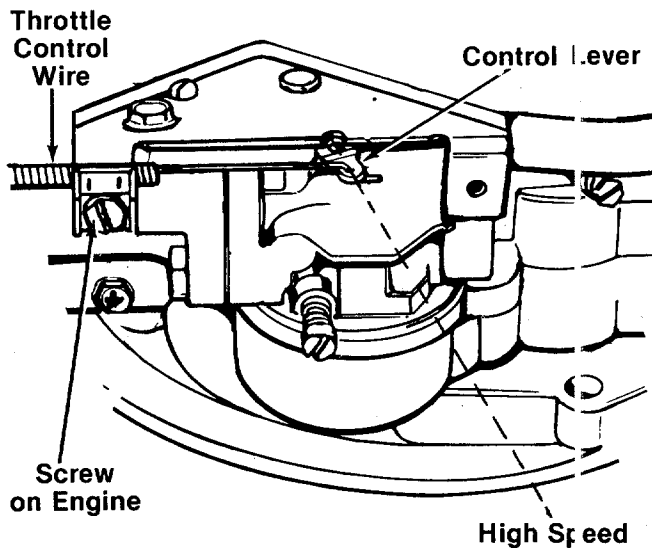

FIGURE 11.

CARBURETOR ADJUSTMENTS



WARNING

If any adjustments are made to the engine while the engine is running (e.g. carburetor), disengage all clutches and blades. Keep clear of all moving parts and be careful of heated surfaces and muffler.

Minor carburetor adjustment may be required to compensate for differences in fuel, temperature, altitude and load.

If carburetor adjustment is required, refer to the separate engine manual packed with your unit.

HEIGHT ADJUSTMENT



WARNING

Before changing the cutting height, stop the engine and disconnect the spark plug wire.

Unscrew the rear axle bolt and place it in one of the four height adjustment holes. The belleville washer must be installed exactly as shown in figure 12 (cupped side against the frame).

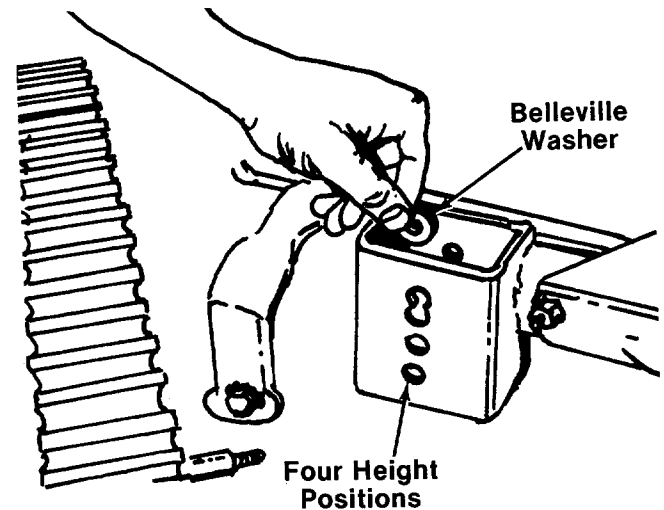

FIGURE 12.

Adjust the front wheels in the same manner. All wheels must be in the same relative position. See figure 13.

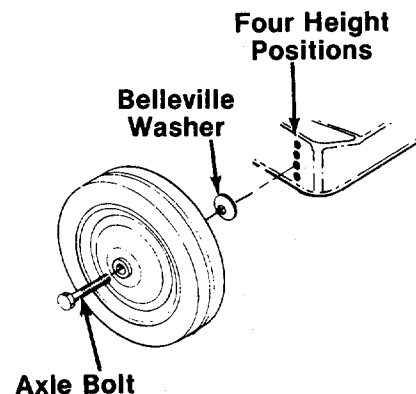

FIGURE 13.

LUBRICATION



WARNING

Always stop engine and disconnect spark plug wire before cleaning, lubricating, or doing any kind of work on the lawn mower.

1. **Wheels**—Front and rear wheel bearings are ball bearing. Lubricate periodically with a few drops of light oil. To lubricate the rear wheels, remove the oil caps and add several drops of oil. Refer to figure 6.

Also, if the wheels are removed for any reason, lubricate the surface of the axle bolt and the inner surface of the wheel with light oil. A 4 oz. plastic bottle of light oil lubricant is available. Order part number 737-0170. Engine oil may also be used.

2. **Throttle**—Periodically lubricate throttle control lever and throttle wire assembly with a few drops of light oil for ease of operation.
3. **Engine**—Follow engine manual for lubrication instructions.
4. **Chute Deflector**—The torsion spring and pivot point should be lubricated periodically with light oil to prevent any rust or binding. Deflector must work freely.
5. **Clutch Control**—Lubricate the pivot point on the clutch handle, the cable and the “Z” fitting on end of cable at least once a season with light oil. The control must operate freely in both directions.
6. The blade spindle bearings are sealed and require no further lubrication.
7. Lubricate the idler brake bracket assembly at the pivot point with an automotive chassis grease at least once a season. Refer to page 16, reference number 51.
8. Lubricate all other linkage after every 25 hours of operation with light oil.

MAINTENANCE

CUTTING BLADE

A. Removal for Sharpening or Replacement



WARNING

Be sure to disconnect and ground the spark plug wire before working on the cutting blade to prevent accidental engine starting.

1. Remove the large bolt and lock washer which holds the blade and adapter to the blade spindle. See figure 14.

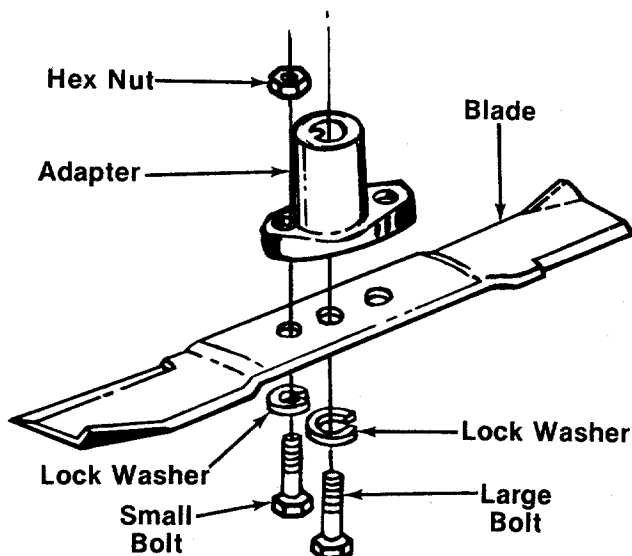

FIGURE 14.

2. Remove the blade and adapter from the spindle.
3. If the blade or blade adapter needs replacing, remove the two small bolts, lock washers and nut which hold the blade to the adapter.



CAUTION

Periodically inspect the blade adapter for cracks, especially if you strike a foreign object. Replace when necessary.

B. Sharpening

Remove the cutting blade by following the directions of the preceding section.

When sharpening the blade, follow the original angle of grind as a guide. It is **extremely important** that each cutting edge receives an equal amount of grinding to prevent an unbalanced blade. An unbalanced blade will cause excessive vibration when rotating at high speeds, may cause damage to the mower, and could break, causing personal injury.

The blade can be tested for balance by balancing it on a round shaft screwdriver. Remove metal from the heavy side until it balances evenly. See figure 15.

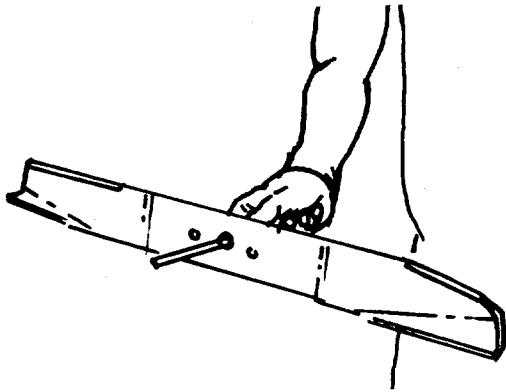

FIGURE 15.



It is recommended that the blade always be removed from the adapter for the best test of balance.

C. Reassembly

Before reassembling the blade and the blade adapter to the unit, lubricate the blade spindle and the inner surface of the blade adapter with light oil. Lubricating the bolt holes, bolts and inner surface of the nuts with light oil is also recommended. A 4 oz. plastic bottle of light oil lubricant is available. Order part number 737-0170. Engine oil may also be used.

When replacing the blade, be sure to install the blade with the side of the blade marked "Bottom" (or with part number) facing the ground when the mower is in the operating position.

Blade Mounting Torque

3/8" Dia. Bolt 375 in. lb. min., 450 in. lb. max.
5/16" Dia. Bolt 150 in. lb. min., 250 in. lb. max.

To insure safe operation of your unit, ALL nuts and bolts must be checked periodically for correct tightness.

DECK

The underside of mower deck should be cleaned after each period of use as grass clippings, leaves, dirt and other matter will accumulate. This accumulation of grass clippings, etc., is undesirable as it will invite rust and corrosion and may cause an uneven discharge of grass clippings at the next cutting.

The deck may be cleaned by tilting the mower forward or on its side and scraping clean with a suitable tool or by washing with a stream of water from a garden hose.



Do not direct the stream of water at a hot engine as damage to the engine may result.

ENGINE OIL

Check oil level before starting and after every 5 hours of operation or each period of use. ADD oil as necessary to keep level FULL TO POINT OF OVERFLOWING. Before removing oil fill plug, clean area around plug to prevent dirt from entering oil fill hole. Engine should be in a level position when checking oil.

Change oil after first 5 hours of operation. Thereafter, change every 25 hours. Change oil while engine is warm. Oil may be drained through oil drain at the base of the engine. Be sure unit is level so that oil drains completely. Oil capacity 1 3/4 pints.

AIR CLEANER

Clean air cleaner every 25 hours under normal conditions. Clean every few hours under extremely dusty conditions. Poor engine performance and flooding usually indicates that the air cleaner should be serviced. To service the air cleaner, refer to the separate engine manual packed with your unit.

SPARK PLUG

The spark plug should be cleaned and the gap reset once a season. Spark plug replacement is recommended at the start of each mowing season; check engine manual for correct plug type and gap specification.

BELT REPLACEMENT

1. Disconnect the spark plug wire and ground it against the engine block.

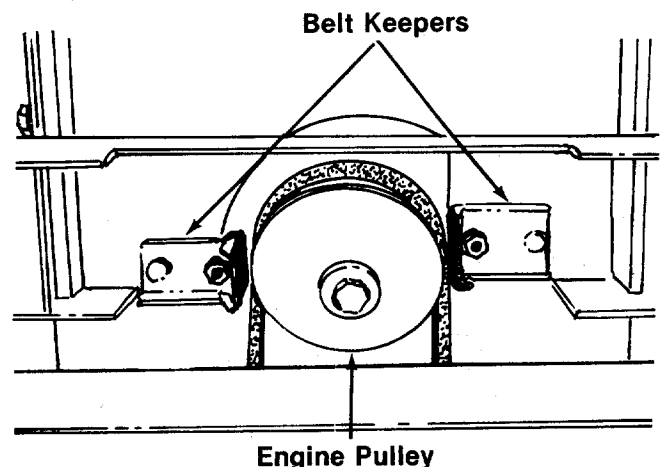

FIGURE 16.

2. Remove the belt keeper from each side of the engine pulley. See figure 16.
3. Remove the spindle cover from the frame.
4. Remove shoulder bolts (belt keepers) from each side of blade pulley. See figure 17.
5. Remove hex lock nut at brake bracket assembly. See figure 17.
6. Remove brake spring, flat washer and brake return spring from brake bracket assembly. See figure 17.
7. Remove the idler pulley from the idler brake bracket assembly. See figure 17.
8. Remove shoulder bolt (belt keeper) next to stationary idler. See figure 17.
9. Remove and replace the belt. Reassemble in reverse order.

OFF-SEASON STORAGE

The following steps should be taken to prepare lawn mower for storage.

1. Clean and lubricate mower thoroughly as described in the lubrication instructions.
2. Refer to engine manual for correct engine storage instructions.
3. Coat mower's cutting blade with chassis grease to prevent rusting.
4. Store mower in a dry, clean area.

NOTE

When storing any type of power equipment in an unventilated or metal storage shed, care should be taken to rustproof the equipment. Using a light oil or silicone, coat the equipment, especially springs, bearings and cables.

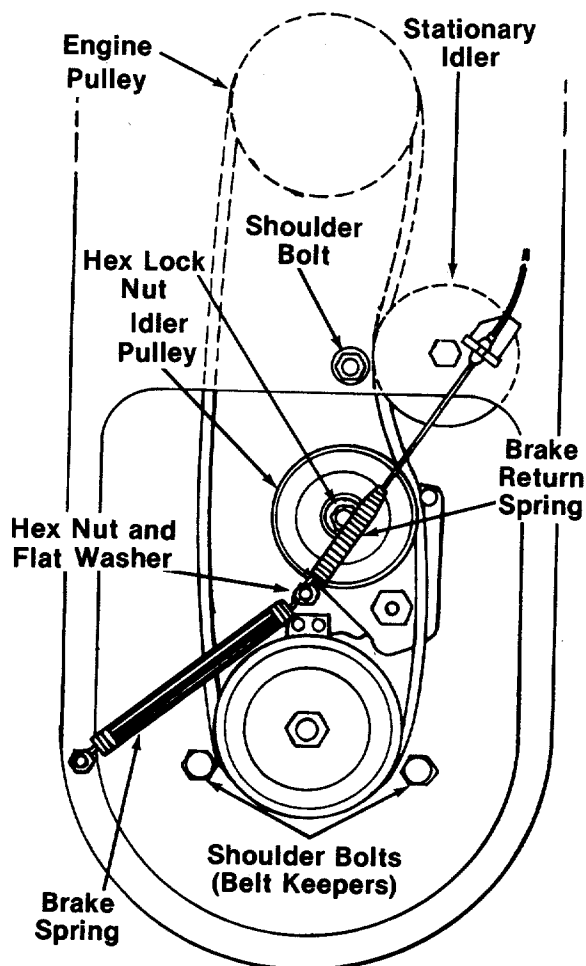

FIGURE 17.

 **NOTE**

The use of any accessory on this Rotary Mower other than those manufactured by the mower manufacturer is **not** recommended.

GRASS CATCHER Model 065 is available as optional equipment for the mower shown in this manual.

**WARNING**

1. DO NOT operate the mower without the entire grass catcher or chute deflector in place.
2. DO NOT operate the mower without the protective shield on the rear of the deck in place.

 **NOTE**

Under normal usage bag material is subject to wear and should be checked periodically. Be sure any replacement bag complies with the mower manufacturer's recommendations.

For replacement bags, use only factory authorized replacement bag No. 764-0217.

Trouble Shooting Chart

| Problem | Cause | Remedy |
|---|---|---|
| 1 Engine fails to start | <p>A Check fuel tank for gas B Spark plug lead wire disconnected C Throttle control lever not in the starting position D Faulty spark plug</p> <p>E Carburetor improperly adjusted, engine flooded</p> <p>F Old stale gasoline</p> | <p>A Fill tank if empty. B Connect lead wire.</p> <p>C Move throttle lever to start position. D Spark should jump gap between control electrode and side electrode. If spark does not jump, replace the spark plug. E Remove spark plug, dry the plug, crank engine with plug removed, and throttle in off position. Replace spark plug and lead wire and resume starting procedures. F Drain and refill with fresh gasoline.</p> |
| 2 Hard starting or loss of power | <p>A Spark plug wire loose B Carburetor improperly adjusted C Dirty air cleaner</p> | <p>A Connect and tighten spark plug wire. B Adjust carburetor. See separate engine manual. C Clean air cleaner as described in separate engine manual.</p> |
| 3 Operation erratic | <p>A Dirt in gas tank B Dirty air cleaner C Water in fuel supply D Vent in gas cap plugged E Carburetor improperly adjusted</p> | <p>A Remove the dirt and fill tank with fresh gas. B Clean air cleaner as described in separate engine manual. C Drain contaminated fuel and fill tank with fresh gas. D Clear vent or replace gas cap. E Adjust carburetor. See separate engine manual.</p> |
| 4 Occasional skip (hesitates) at high speed | <p>A Carburetor idle speed too slow B Spark plug gap too close C Carburetor idle mixture adjustment improperly set</p> | <p>A Adjust carburetor. See separate engine manual. B Adjust to .030". C Adjust carburetor. See separate engine manual.</p> |
| 5 Idles poorly | <p>A Spark plug fouled, faulty, or gap too wide B Carburetor improperly adjusted C Dirty air cleaner</p> | <p>A Reset gap to .030" or replace spark plug. B Adjust carburetor. See separate engine manual. C Clean air cleaner as described in separate engine manual.</p> |
| 6 Engine overheats | <p>A Carburetor not adjusted properly B Air flow restricted</p> <p>C Engine oil level low</p> | <p>A Adjust carburetor. See separate engine manual. B Remove blower housing and clean as described in separate engine manual. C Fill crankcase with the proper oil.</p> |
| 7 Excessive vibration | <p>A Cutting blade loose or unbalanced B Bent blade</p> | <p>A Tighten blade and adapter. Balance blade. B Replace blade.</p> |

Note: For repairs beyond the minor adjustments listed above contact your local authorized service dealer.

Model 533

Meets CPSC Blade Safety Requirements

| Lot/Model | Mfg. Date |
|-----------|-----------|
| | |

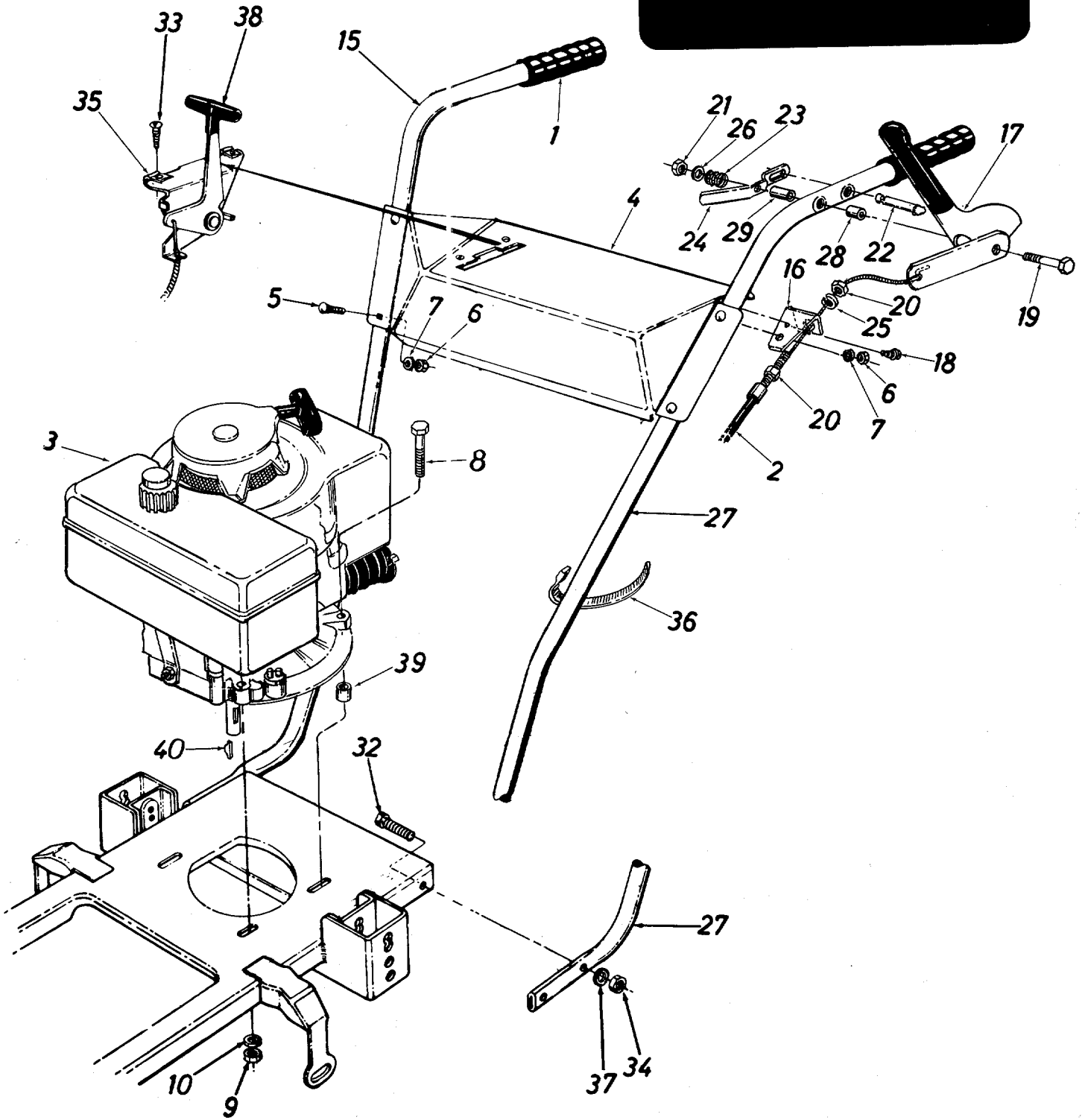

Model 533

PARTS LIST FOR MODEL 533 ROTARY MOWER

| REF. NO. | PART NO. | COLOR CODE | DESCRIPTION | NEW PART |
|----------|----------|------------|--|----------|
| 1 | 720-0204 | | Grip | |
| 2 | 746-0507 | | Clutch Cable—39.0" | |
| 3 | — | | Engine | |
| 4 | 15336 | | Handle Panel | |
| 5 | 710-0458 | | Carr. Bolt 5/16-18 x 1.75" Lg.* | |
| 6 | 712-0267 | | Hex Nut 5/16-18 Thd.* | |
| 7 | 736-0119 | | L-Wash. 5/16" I.D.* | |
| 8 | 710-0409 | | Hex Bolt 5/16-24 x 1.75" Lg.* | |
| 9 | 712-0123 | | Hex Nut 5/16-24 Thd.* | |
| 10 | 736-0170 | | L-Wash. 5/16" I.D. | |
| 15 | 749-0560 | | Handle—R.H. | |
| 16 | 16047 | | Clutch Cable Brkt. | |
| 17 | 15853 | | Blade Clutch Grip Ass'y. | |
| 18 | 710-0599 | | Hex Wash. S-Tap Scr. 1/4-20 x .50" Lg. | |
| 19 | 710-0641 | | Hex Bolt 1/4-20 x 2.25" Lg.* | |
| 20 | 712-0256 | | Hex Jam Nut 5/16-24 Thd. | |
| 21 | 712-0291 | | Hex Cent. L-Nut 1/4-20 Thd. | |
| 22 | 711-0719 | | Lock Pin | |
| 23 | 732-0334 | | Compression Spring | |
| 24 | 732-0441 | | Lockout Spring | |
| 25 | 736-0119 | | L-Wash. 5/16" I.D.* | |
| 26 | 736-0498 | | Internal Tooth L-Wash. | |
| 27 | 749-0561 | | Handle—L.H. | |
| 28 | 750-0565 | | Spacer .44" Lg. | |
| 29 | 750-0566 | | Spacer 1.03" Lg. | |
| 32 | 710-0158 | | Hex Bolt 5/16-24 x 1.25" Lg.* | |
| 33 | 710-0224 | | Hex Wash. Hd. AB-Tap Scr. #10 x .50" Lg. | |
| 34 | 712-0123 | | Hex Nut 5/16-24 Thd.* | |
| 35 | 712-0344 | | Speed Nut 10Z U-Type | |
| 36 | 725-0157 | | Cable Tie | |
| 37 | 736-0119 | | L-Wash. 5/16" I.D.* | |
| 38 | 746-0543 | | Throttle Control | |
| 39 | 711-0250 | | Spacer | |
| 40 | 714-0138 | | Woodruff Key 5/32" x 5/8" Dia. | |

*For faster service obtain standard nuts, bolts and washers locally. If these items cannot be obtained locally, order by part number and size as shown on parts list.

(462—Red Flake) When ordering parts, if color or finish is important, use the appropriate color code shown at left. (e.g. Red Flake Finish—11992 (462).)



NOTE

This instruction manual covers various models and all specifications shown do not necessarily apply to your model. Specifications subject to change without notice or obligation.

NOTE: The engine is not under warranty by the mower manufacturer...If repairs or service is needed on the engine, please contact your nearest authorized engine service outlet. Check the "Yellow Pages" of your telephone book under "Engines—Gasoline."

Find It Fast
In The
Yellow Pages

Model 533

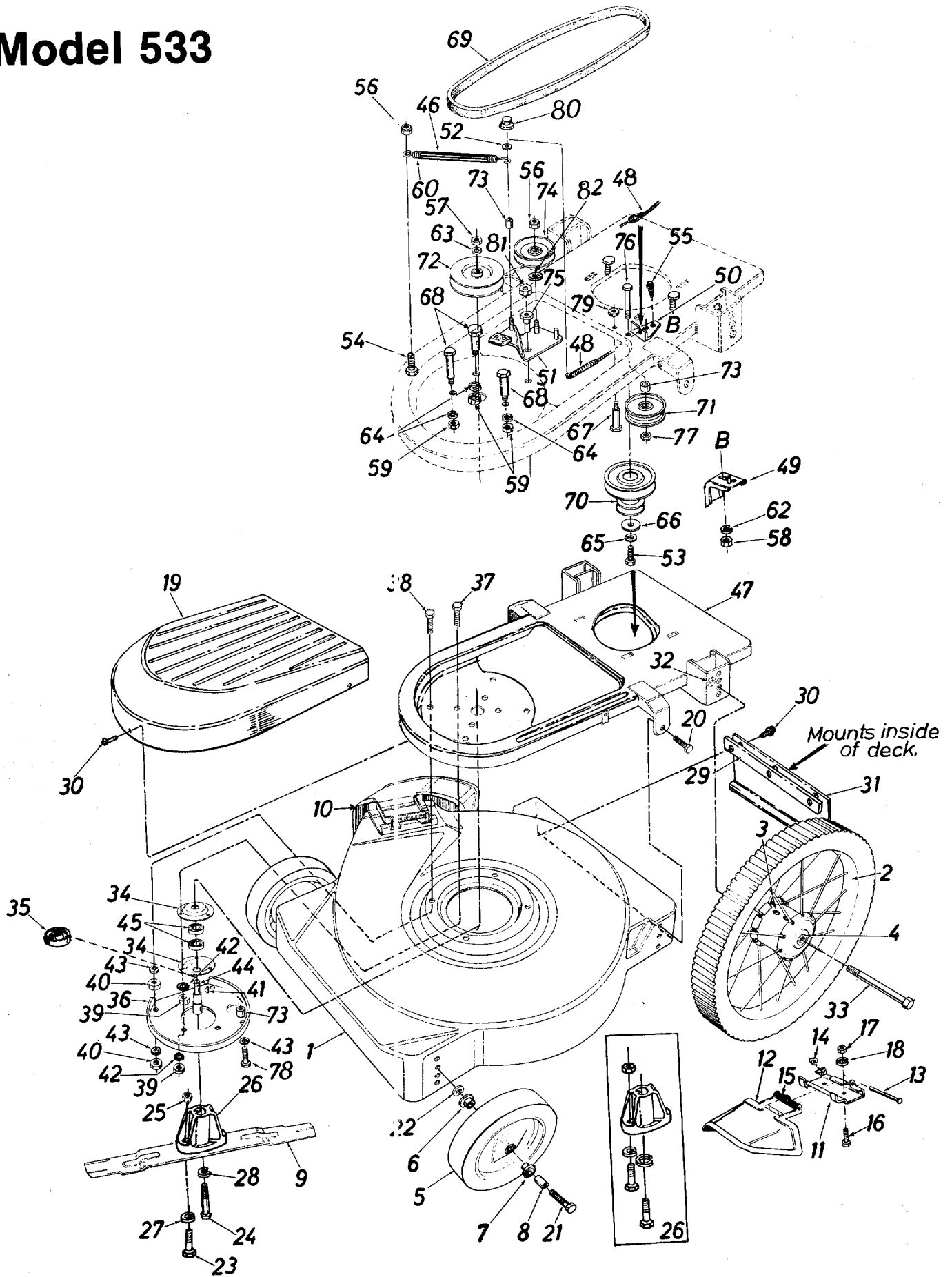

Model 533

PARTS LIST FOR MODEL 533 ROTARY MOWER

| REF. NO. | PART NO. | COLOR CODE | DESCRIPTION | NEW PART | REF. NO. | PART NO. | COLOR CODE | DESCRIPTION | NEW PART |
|----------|----------|------------|--|----------|----------|----------|------------|--|----------|
| 1 | 14918 | | 22" Deck Ass'y. | | 41 | 714-0365 | | #6 Hi-Pro Key 5/32" x 5/8" Dia. | |
| 2 | 734-0438 | | 16" Wheel Ass'y. Comp. | | 42 | 736-0119 | | L-Wash. 5/16" I.D.* | |
| | 734-0180 | | Rim Only | | 43 | 736-0169 | | L-Wash. 3/8" I.D.* | |
| | 734-0391 | | Tire Only | | 44 | 738-0552 | | Blade Spindle | |
| 3 | 718-0132 | | Oil Cap | | 45 | 749-0919 | | Ball Bearing .787" I.D. x 1.85" O.D. | |
| 4 | 741-0113 | | Ball Bearing | | 46 | 731-0675 | | Plastic Tube | |
| 5 | 734-0642 | | Wheel Ass'y. Comp. | | 47 | 15862 | | Frame Ass'y. | |
| | | | 8 x 1.75 (Twinline Tread) | | 48 | 746-0507 | | Clutch Cable—39.0" | |
| | 734-0644 | | Wheel Ass'y. Comp. 8 x 1.75 (Waffle Tread) | | 49 | 10426 | | Belt Keeper Ass'y. | |
| 6 | 741-0267 | | Flanged Ball Bearing 3/8" I.D. | | 50 | 15093 | | Clutch Cable Brkt. | |
| 7 | 741-0484 | | Flanged Ball Bearing 1/2" I.D. | | 51 | 15851 | | Idler Brake Brkt. Ass'y. | |
| 8 | 750-0434 | | Spacer | | 52 | 736-0275 | | Fl-Wash. .343" I.D. x .687" O.D. x .063 | |
| 9 | 742-0125 | | 22" Blade | | 53 | 710-0152 | | Hex Bolt 3/8-24 x 1.00" Lg.* | |
| 10 | 11679 | | Chute Deflector Ass'y. Comp. | | 54 | 710-0252 | | Hex Bolt 1/4-20 x .75" Lg.* | |
| 11 | 11130 | | Adapter Plate | | 55 | 710-0776 | | Hex Wash. Hd. AB-Tap Scr. 1/4" x .62" Lg. | |
| 12 | 11141 | | Deflector Ass'y. | | 56 | 712-0107 | | Hex Cent. L-Nut 1/4-20 Thd. | |
| 13 | 711-0555 | | Pivot Pin | | 57 | 712-0242 | | Hex Jam Nut 5/8-11 Thd. | |
| 14 | 726-0106 | | Push Cap 1/4" Rod | | 58 | 712-0267 | | Hex Nut 5/16-18 Thd.* | |
| 15 | 732-0253 | | Torsion Spring | | 59 | 712-0798 | | Hex Nut 3/8-16 Thd.* | |
| 16 | 710-0289 | | Hex Bolt 1/4-20 x .50" Lg.* | | 60 | 732-0308 | | Extension Spring | |
| 17 | 712-0287 | | Hex Nut 1/4-20 Thd.* | | 62 | 736-0119 | | L-Wash. 5/16" I.D.* | |
| 18 | 736-0329 | | L-Wash. 1/4" I.D.* | | 63 | 736-0158 | | L-Wash. 5/8" I.D.* | |
| 19 | 08295 | | Blade Spindle Cover | | 64 | 736-0169 | | L-Wash. 3/8" I.D.* | |
| 20 | 710-0209 | | Hex Sems Scr. 3/8-16 x .62" | | 65 | 736-0217 | | L-Wash. 3/8" I.D.—H.D. | |
| 21 | 710-0427 | | Hex Bolt 3/8-16 x 2.0" Lg. | | 66 | 736-0235 | | Fl-Wash. .406" I.D. x 1.25" O.D. | |
| 22 | 736-0105 | | Bell-Wash. .400" I.D. x .88" | | 67 | 738-0144 | | Shld. Bolt .498" Dia. x 1.64" | |
| 23 | 710-0888 | | Hex Bolt 5/16-24 x 1.00" Lg. | | 68 | 738-0213 | | Shld. Bolt .498" Dia. x 1.450" | |
| 24 | 710-0331 | | Hex Bolt 3/8-24 x 2.25" Lg. | | 69 | 754-0274 | | V-Belt 1/2" x 44.0" Lg. (Blade) | |
| 25 | 712-0123 | | Hex Nut 5/16-24 Thd.* | | 70 | 756-0412 | | Engine Pulley | |
| 26 | 753-0348 | | Blade Adapter Kit | | 71 | 756-0405 | | Flat Idler Pulley | |
| 27 | 736-0119 | | L-Wash. 5/16" I.D.* | | 72 | 756-0392 | | 1/2" V-Pulley .503" I.D. x 4.50" O.D. | |
| 28 | 736-0217 | | L-Wash. 3/8" I.D.—H.D. | | 73 | 750-0497 | | Spacer .376 I.D. x .622 O.D. x .44" Lg. | |
| 29 | 14836 | | Retaining Strip | | 74 | 756-0293 | | 4.0" Idler Pulley | |
| 30 | 710-0776 | | Hex Wash. Hd. AB-Tap Scr. 1/4" x .62" Lg. | | 75 | 738-0563 | | Shoulder Spacer | |
| 31 | 731-0587 | | Rear Flap Ass'y. | | 76 | 710-0539 | | Hex Bolt 3/8-24 x 1.75" Lg.* | |
| 32 | 736-0105 | | Bell-Wash. .400" I.D. x .88" | | 77 | 712-0296 | | Hex L-Nut 3/8-24 Thd. | |
| 33 | 738-0114 | | Rear Axle Bolt | | 78 | 710-0724 | | Hex Bolt 3/8-24 x 1.5" Lg.* | |
| 34 | 08253 | | Bearing Housing | | 79 | 712-0181 | | Hex L-Nut 3/8-16 Thd. | |
| 35 | 13703 | | Bearing Shield | | 80 | 726-0106 | | Push Cap 1/4" | |
| 36 | 15486 | | Blade Reinforcement Plate | | 81 | 712-0711 | | Hex Jam Nut 3/8-24 Thd. | |
| 37 | 710-0158 | | Hex Bolt 5/16-24 x 1.25" Lg.* | | 82 | 736-0235 | | Fl-Wash. .406 I.D. x 1.25 O.D. x .172 Thk. | |
| 38 | 710-0191 | | Hex Bolt 3/8-24 x 1.25" Lg. | | | | | | |
| 39 | 712-0123 | | Hex Nut 5/16-24 Thd.* | | | | | | |
| 40 | 712-0241 | | Hex Nut 3/8-24 Thd.* | | | | | | |

*For faster service obtain standard nuts, bolts and washers locally. If these items cannot be obtained locally, order by part number and size as shown on parts list.

(462—Red Flake) When ordering parts, if color or finish is important, use the appropriate color code shown at left. (e.g. Red Flake Finish—11992 (462).)

†Order Kit 753-0218



PARTS INFORMATION

POWER EQUIPMENT PARTS AND SERVICE

Parts and service are available through the authorized service firms listed below. All orders should specify the model number of your unit, part numbers, description of parts and the quantity of each part required.

NOTE: If any parts are found to be missing or defective upon assembly of this unit, write to advise the factory so that immediate replacement can be made

| | | |
|---|---|-------|
| ALABAMA | BIRMINGHAM | |
| Auto Electric & Carburetor Co. | 2625 4th Ave. S. | 35233 |
| ARKANSAS | NORTH LITTLE ROCK | |
| Sutton's Lawn Mower Shop | 5301 Roundtop Drive Box 368, Rt. 4 | 72117 |
| CALIFORNIA | PORTERVILLE | |
| Billious | 75 North D Street | 93257 |
| COLORADO | DENVER | |
| Spitzer Industrial Products Co. | 6601 N. Washington St. | 80229 |
| FLORIDA | JACKSONVILLE | |
| Radco Distributors | 4909 Victor St. Box 5459 | 32207 |
| | HIALEAH | |
| Small Eng. Dist. | 7995 W. 26th Court | 33016 |
| GEORGIA | EAST POINT | |
| East Point Cycle & Key Inc. | 2834 Church St. | 30344 |
| ILLINOIS | LYONS | |
| Keen Edge Co. | 8615 Ogden Ave. | 60534 |
| INDIANA | ELKHART | |
| Parts & Sales Inc. | 2101 Industrial Pkwy. | 46516 |
| IOWA | DUBUQUE | |
| Power Lawn & Garden Equip. | 2551 J.F. Kennedy | 52001 |
| LOUISIANA | NEW ORLEANS | |
| Suhren Engine Co. | 8330 Earhart Blvd. | 70118 |
| MARYLAND | TAKOMA PARK | |
| Center Supply Co. | 6867 New Hampshire Ave. | 20912 |
| MASSACHUSETTS | SPRINGFIELD | |
| Morton B. Collins Co. | 300 Birnie Ave. | 01107 |
| MICHIGAN | LANSING | |
| Lorenz Service Co. | 2500 S. Pennsylvania | 48910 |
| | MOUNT CLEMENS | |
| Power Equipment Dist. | 340 Hubbard | 48043 |
| MINNESOTA | HOPKINS | |
| Hance Distributing Inc. | 420 Excelsior Ave. W. | 55343 |
| MISSISSIPPI | BILOXI | |
| Biloxi Sales & Service, Inc. | 506 Caillavet St. | 39533 |
| MISSOURI | KANSAS CITY | |
| Automotive Equip. Service | 3117 Holmes St. | 64109 |
| | ST. JOSEPH | |
| Ross-Frazier Supply Co. | 8th and Monterey | 64503 |
| | ST. LOUIS | |
| Henzler, Inc. | 2015 Lemay Ferry Rd. | 63125 |
| NEW JERSEY | BELLMAWR | |
| Lawnmower Parts Inc. | 717 Creek Rd. | 08030 |
| NEW MEXICO | ALBUQUERQUE | |
| Spitzer Eng. & Parts Co. | 1023 Third Ave. N.W. | 37103 |
| NEW YORK | CARTHAGE | |
| Gamble Dist., Inc. | West End Ave. | 13619 |

BRIGGS AND STRATTON, TECUMSEH AND PEERLESS PARTS AND SERVICE

Briggs & Stratton, Tecumseh and Peerless parts and service should be handled by your nearest authorized engine service firm. Check the yellow pages of your telephone directory under the listing **Engines—Gasoline**, Briggs & Stratton or Tecumseh Lauson.

| | | |
|--|---|-------|
| OHIO | CARROLL | |
| Stebe's Mid-State Mower Supply | Box 366, 71 High St. | 43112 |
| | CLEVELAND | |
| Bleckrie, Inc. | 7900 Lorain Ave. | 44102 |
| | WADSWORTH | |
| National Central | 687 Seville Rd. | 44281 |
| | YOUNGSTOWN | |
| Burton Supply Co. | 1301 Logan Ave. Box 929 | 44501 |
| OKLAHOMA | MUSKOGEE | |
| Victory Motors, Inc. | 605 S. Cherokee | 74401 |
| OREGON | PORTLAND | |
| Kenton Supply Co. | 8216 N. Denver Ave. | 97217 |
| PENNSYLVANIA | HARRISBURG | |
| EECO Inc. | 4021 N. 6th St. | 17110 |
| | PHILADELPHIA | |
| Thompson Rubber Co. | 5222-24 N. Fifth St. | 19120 |
| | PITTSBURGH | |
| Bluemont Co. | 11125 Frankstown Rd. | 15235 |
| | PUNXSUTAWNEY | |
| Frank Roberts & Sons | R.D. 2 | 15767 |
| | SCRANTON | |
| Scranton Auto Ignition Co. | 1133-35 Wyoming Ave. | 18509 |
| TENNESSEE | KNOXVILLE | |
| Master Repair Service | 2000 Western Ave. | 37921 |
| | MEMPHIS | |
| American Sales & Service, Inc. | 3035-43 Bellbrook | 38116 |
| TEXAS | DALLAS | |
| Marr Brothers, Inc. | 423 E. Jefferson | 75203 |
| | FORT WORTH | |
| Woodson Sales Corp. | 6733 Baker Blvd. Hwy. 10 | 76118 |
| | HOUSTON | |
| Bullard Supply Co. | 2409 Commerce St. | 77003 |
| | SAN ANTONIO | |
| Engine House Inc. | 8610 Botts Lane P.O. Box 17867 | 78217 |
| UTAH | BOUNTIFUL | |
| Powered Products | 485 N 500 W. | 84010 |
| VIRGINIA | ASHLAND | |
| RBI Corp. | 101 Cedar Ridge Dr. | 23005 |
| WASHINGTON | SEATTLE | |
| Equip. Northwest | 1410 14th Ave. | 98122 |
| WISCONSIN | CHILTON | |
| Horst Dist. Inc. | 444 N. Madison St. | 53014 |
| NORTH CAROLINA | GOLDSBORO | |
| Smith Hardware Co. | 515 N. George St. | 27530 |
| | GREENSBORO | |
| Dixie Sales Company | 335 N. Green | 27402 |

WARRANTY PARTS AND SERVICE POLICY

(0484)

The purpose of warranty is to protect the customer from defects in workmanship and materials, defects which are NOT detected at the time of manufacture. It does not provide for the unlimited and unrestricted replacement of parts. Use and maintenance are the responsibility of the customer. The manufacturer cannot assume responsibility for conditions over which it has no control. Simply put, if it's the manufacturer's fault, it's the manufacturer's responsibility; if it's the customer's fault, it's the customer's responsibility.

CLAIMS AGAINST THE MANUFACTURER'S WARRANTY INCLUDES:

1. Replacement of Missing Parts on new equipment.
2. Replacement of Defective Parts within the warranty period.
3. Repair of Defects within the warranty period.

All claims MUST be substantiated with the following information:

1. Model Number of unit involved.
2. Date unit was purchased or first put into service.
3. Date of failure.
4. Nature of failure.