

OWNER'S GUIDE

**Model Nos. 110-030
110-050 110-090**

10 CENTS

ROTARY MOWER

WARRANTY

For one year from date of purchase, MTD Products, Inc., will replace for the original purchaser, free of charge, F.O.B. factory or authorized service firm, any part or parts found to be defective in material or workmanship. All transportation charges on parts submitted for replacement under this warranty must be paid by the purchaser. This warranty does not include replacement of parts which become inoperative through misuse, excessive use, accident, neglect, improper maintenance or alterations by unauthorized persons. This warranty does not include the engine, motor, battery, battery charger or any component parts thereof. For service on these units refer to the applicable manufacturer's warranty.

The above warranty will apply only to the original owner and will be effective only if the warranty card has been properly processed. It will not apply where the unit has been used commercially.

Warranty service is available through your local authorized service dealer or distributor. UNDER NO CIRCUMSTANCES WILL THE RETURN OF A COMPLETE UNIT BE ACCEPTED BY THE FACTORY UNLESS PRIOR WRITTEN PERMISSION HAS BEEN EXTENDED.

SAFETY RULES

Your rotary mower is a precision piece of power equipment, not a plaything. Therefore exercise extreme caution at all times.

1. Remove all sticks, stones, wire and other hazardous items from lawn before mowing. Such items are dangerous to both the mower and individuals in the vicinity of the mower.
2. Always disconnect spark plug cable during repairs or refueling operations.
3. Always start engine from side opposite discharge chute.
4. NEVER place hands or feet under mower or near discharge chute while engine is running.
5. Do not tilt mower at extreme angle while engine is running. Cut grass on hills and banks sideways, not up and down.
6. Always stop engine when not cutting grass.
7. Do not fill gas tank while engine is running. Do not spill gasoline on hot engine.
8. Keep children and pets away from area at all times during mowing operation. Never allow mower to discharge grass toward any person.
9. Do not attempt to start engine while mower is resting in high grass.
10. Check all nuts and bolts, particularly the blade bolts, for tightness. This is especially important during the initial operation period. Make this same check periodically thereafter.

NOTE: Should excessive vibration develop, check your blade and crankshaft immediately. Do not operate mower with an unbalanced blade, a damaged blade or a damaged crankshaft.

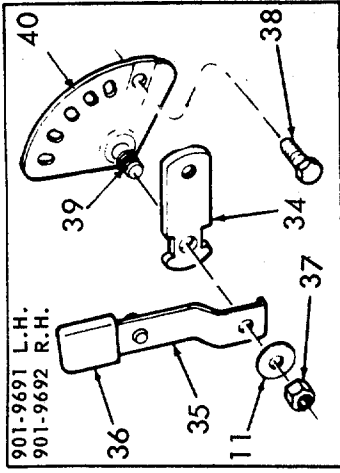

When ordering parts give the following information:

1. Model number
2. Part number
3. Part name
4. Color of part

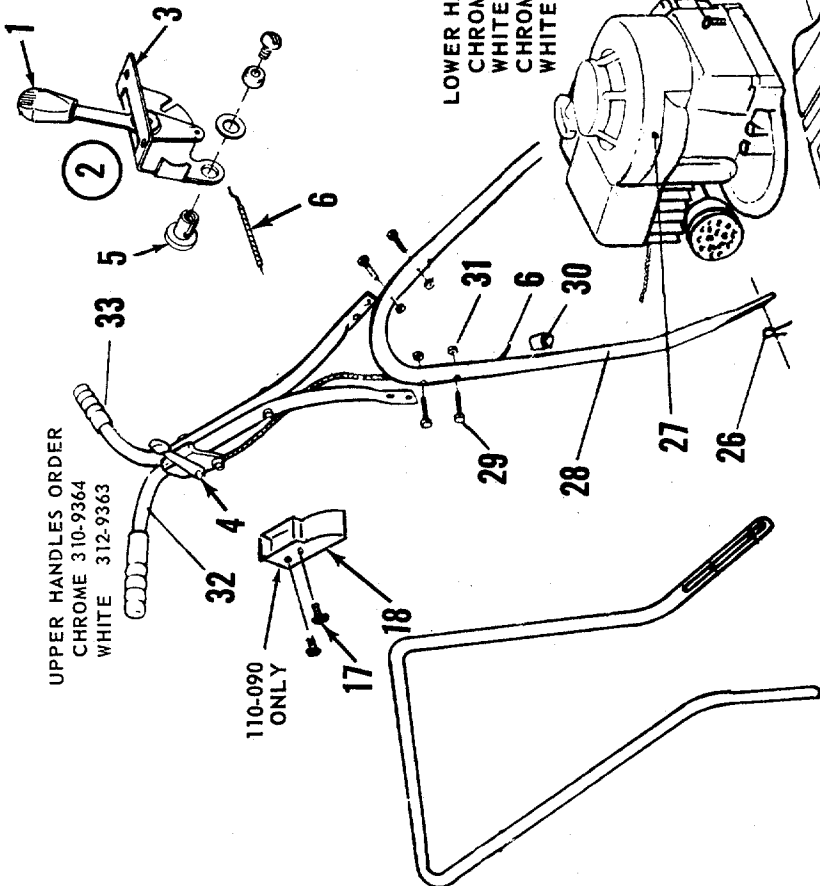

UPPER HANDLES ORDER
CHROME 310-9364
WHITE 312-9363

110-090
ONLY

LOWER HANDLES ORDER:
CHROME 310-7016 19"
WHITE 312-7039 19"
CHROME 310-7036 22"
WHITE 312-7040 22"

WHERE LOOP HANDLES ARE USED
ORDER: CHROME 310-7585
WHITE 312-7584

BLADE ADAPTER KIT
901-7969

NOTE: Easy Height Adjuster MAY or MAY NOT be used on your unit.

Illus. No.	Part No.	DESCRIPTION
34	310-7492	Wheel Pivot Bar
35	310-8313	Spring Lever Assembly
36	305-7520	Red Knobs
37	712-214	GRIPCO Locknut 3/8-24 Thread
38	710-209	Sems Hex Head Cap Screw 3/8-16 x 5/8 Long
39	710-362	Hex Bolt Special
40	738-102	Axle Bolt
40	310-9682	Index Plate R. H.
40	310-9683	Index Plate L. H.

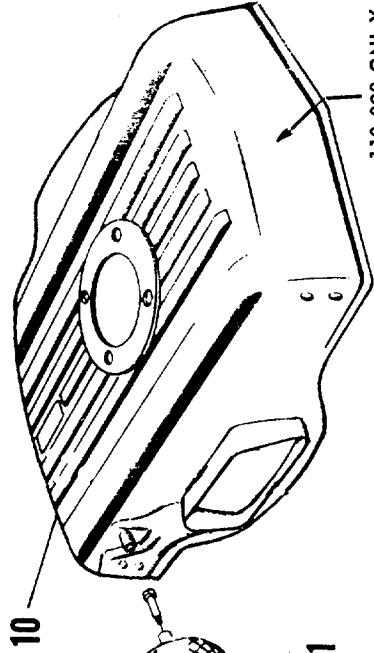

110-090 ONLY

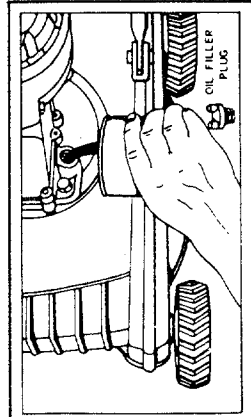

CHANGE OIL

Change oil after first 5 hours of operation while engine is warm. Thereafter change oil every 25 hours of operation while engine is warm. Engine may be drained through oil filler opening. Be sure to replace drain plug and oil filler cap.

110-030
110-050
110-090

Illus. No.	110-030 Part No.	110-050 Part No.	110-090 Part No.	DESCRIPTION
1	305-7470	305-7470	305-7470	Knob Control
2	310-8842	310-8842	310-10029	Control Throttle (complete)
3	310-8841	310-8841	310-9996	Control Bracket Assembly - Throttle ▲
4	710-606	710-606	710-606	Hex Head Cap Screw 1/4-20 x 1-1/2 (yellow)
5	901-7627	901-7627	901-7627	Ferrule Assembly (complete)
6	732-141	732-141	732-141	Conduit and Wire - Throttle
7	710-158	710-158	710-158	Hex Head Cap Screw 5/16-24 x 1-1/4 *
8	736-119	736-119	736-119	Spring Lockwasher 5/16 Screw *
9	712-123	712-123	712-123	Hex Nut 5/16-24 Thread *
10	414-8754	414-8755	414-8756	Deck Assembly
11	736-105	736-105	736-105	Belleville Washer 3/8 I.D.
12	710-113	710-113	710-113	Hex Head Cap Screw 3/8-24 x 1-5/8 long
13	710-117	710-117	710-117	Hex Head Cap Screw 5/16-24 x 1 long
14	736-169	736-169	736-169	Spring Lockwasher 3/8 Screw *
15	748-100	748-100	748-100	Blade Adapter
16	712-123	712-123	712-123	Hex Nut 5/16-24 Thread *
17	—	—	710-148	Self Tap Screw No. 8-32 x 3/8" long *
18	—	—	394-9973	Control Cover
19	714-365	714-365	714-365	Hi Pro Key #H.P. 505 *
20	736-119	736-119	736-119	Spring Lockwasher 5/16 Screw *
21				
22	312-7714	312-7581	312-7581	Blade
23	504-9392	505-9392	503-9383	Wheel Assembly
24	305-7006	305-7006	741-114	Bearings Wheel
25	738-213	738-213	738-213	Axle Bolt
26	714-507	714-507	714-507	Cotter Pin 3/32 dia. x 3/4 long *
27	—	—	—	Engine
28	312-7039	312-7040	310-7036	Handle Lower
29	710-106	710-106	710-106	Hex Head Cap Screw 1/4-20 x 1-1/4 long *
30	746-145	746-145	746-145	Cable Clip
31	712-107	712-107	712-107	Hex Centerlock Nut 1/4-20 Thread *
32	312-9363	312-9363	310-9364	Handle Upper (2 required)
33	305-7071	305-7071	305-7072	Grip
	901-7969	901-7969	901-7969	Blade Adapter Kit (Blade Not Included)

* For faster service obtain standard nuts, bolts and washers locally. If these items cannot be obtained locally, order by part number and size as shown on parts list.

▲ Included in Part No. 310-8842 Control-Throttle (complete)

▲ Included in Part No. 310-10029 Control-Throttle (complete)

When ordering replacement parts, be sure to specify your mower model number, part number, description of part, and the number of parts required . . . Parts and service should be handled by your nearest authorized service firm as recommended by your dealer. Request for parts and service received at the factory will be forwarded to the appropriate Central Service Distributor in your area for handling.

NOTE! This instruction manual covers various models, and all accessories shown do not necessarily apply to your model mower.

MTD PRODUCTS INC extends its warranty only on the mower. If repairs or service is needed on the engine, please contact your nearest authorized engine service outlet. Check the "Yellow Pages" of your telephone book under "Engines - Gasoline."



ASSEMBLY

Your new mower is shipped completely assembled with the exception of the handle.

1. Remove lawn mower and all parts from carton. Make certain that all loose parts and literature are removed from carton before carton is discarded.
2. Extend throttle control assembly, which is attached to rear of mower and place on floor. **CAUTION:** Do not bend or kink control wire.
3. A. Snap lower handle into position on two lugs which extend from either side on the rear of the deck.
B. Assemble the two upper handle parts with cap screws and locknuts provided in parts bag. The yellow cap screw should be used to attach throttle control assembly to upper handle as shown in diagram. Do not tighten nuts.
C. Attach upper handle assembly to lower handle with cap screws and locknuts. Tighten all nuts.
D. Secure control wire to lower handle with cable clips.
E. (110-090) Place the plastic control cover over the throttle control and secure with two self-tapping screws.
4. Check blade bolts for proper tightness.

OPERATION

NOTE: For shipping purposes your mower is set with the wheels in a low cutting height position. For best results raise the cutting position until it is determined which height is best for your lawn. See adjustments.

1. Service engine with gas and oil. See Engine Manual packed with lawn mower for complete instructions for the care and maintenance of engine. *Read Directions Carefully.*
2. When ready to start engine, place throttle control lever, on handle, in "START" position and start engine in accordance with instructions in Engine Manual. After engine starts, move throttle control lever, on handle, to desired engine speed. The engine is stopped by placing control lever on handle in the "STOP" position.
3. Be sure that lawn is clear of stones, sticks, wire or other objects which could damage lawn mower or engine. For best results and to insure more even grass distribution, do not mow when lawn is excessively wet.

ADJUSTMENTS

CAUTION: Do not at any time make any adjustment to lawn mower without first stopping engine and disconnecting spark plug wire.

EASY CUTTING HEIGHT - An adjusting plate and thumb lever at each wheel position provides cutting height adjustment. Each adjusting plate has five holes. Height of cut will be changed when the thumb lever is moved from one hole to another. Simply depress thumb lever towards wheel and move wheel and lever assembly to desired position. Cutting height will be raised as lever is moved toward front and lowered as lever is moved toward rear. All wheels must be positioned in relative height of cut positions.

STANDARD CUTTING HEIGHT - Adjustment may be made by removing and moving wheel studs to desired position. Cutting heights will be raised as wheel studs are moved to a lower hole and lowered as wheel studs are moved to a higher hole in the deck. All wheel studs must be mounted in a relative position to the deck.

THROTTLE - If adjustment becomes necessary, the throttle control wire assembly can be reset as follows:

1. Loosen, but do not remove, screw securing throttle control wire assembly at engine.
2. Move throttle control lever on handle to "FAST" position.
3. Move lever, to which control wire is fastened at engine, to full open position and retighten screw to secure throttle control wire assembly.

LUBRICATION

IMPORTANT: Always stop engine and disconnect spark plug wire before cleaning, lubricating or doing any kind of work on lawn mower.

WHEELS - Wheel bearings are of lifetime Fortiflex. They require no lubrication.

THROTTLE - Periodically lubricate throttle control lever and throttle wire assembly with a few drops of light oil (S.A.E. No. 10 or 20) for ease of operation.

ENGINE - Follow engine manual for lubrication instructions.

MAINTENANCE

CUTTING BLADE: The blade may easily be removed for grinding or replacement as follows:

1. Remove bolt and lock washer holding blade and hub assembly to engine crankshaft.
2. Remove blade and hub assembly from engine crankshaft.
3. Remove two bolts, lock washers and nuts holding blade to blade hub.

When sharpening blade, follow the original angle of grind as a guide. It is extremely important that each cutting edge receives an equal amount of grinding to prevent an unbalanced blade. An unbalanced blade will cause excessive vibration when rotating at high speeds and may cause damage to the mower.

Upon reassembly, make certain all parts are assembled properly and tightened securely.

DECK - The underside of mower deck should be cleaned after each period of use as grass clippings, leaves, dirt and other matter will accumulate. This accumulation of grass clippings, etc., is undesirable as it will invite rust and corrosion and may cause an uneven discharge of grass clippings at the next cutting.

The deck may be cleaned by tilting the mower forward or on its left side and scraping clean with a suitable tool or by washing with a stream of water from a garden hose. **CAUTION:** Do not direct the stream of water at a hot engine as damage to the engine may result.

STORAGE - The following steps should be taken to prepare lawn mower for storage.

1. Clean and lubricate mower thoroughly as described in the preceding instructions.
2. Refer to engine manual for correct engine storage instructions.
3. Coat mower's cutting blade with chassis grease to prevent rusting.
4. Place blocks under deck to raise tires clear of floor.
5. Store mower in a dry, clean area.

USING YOUR ROTARY MOWER

For the best results do not cut wet grass because it tends to stick to the underside of the mower, thus preventing proper discharge of grass clippings. If wet grass must be cut, reduce engine speed and walking speed to help distribute the clippings more effectively.

New grass should be treated as wet grass, otherwise a normal walking speed is about the right pace for efficient mowing. The best mowing pattern is one that allows the clippings to discharge towards the uncut part of the lawn. This permits recutting of the clippings to further pulverize them. When cutting high weeds, discharge towards cut portion then recut at right angles to first direction.

Lawn should be cut in the fall as long as there is growth.