

OWNER'S GUIDE

Model Nos. 110-011
110-020

10 CENTS

ROTARY MOWER

WARRANTY

For one year from date of purchase, MTD Products, Inc., will replace for the original purchaser, free of charge, F.O.B. factory or authorized service firm, any part or parts found to be defective in material or workmanship. All transportation charges on parts submitted for replacement under this warranty must be paid by the purchaser. This warranty does not include replacement of parts which become inoperative through misuse, excessive use, accident, neglect, improper maintenance or alterations by unauthorized persons. This warranty does not include the engine, motor, battery, battery charger or any component parts thereof. For service on these units refer to the applicable manufacturer's warranty.

The above warranty will apply only to the original owner and will be effective only if the warranty card has been properly processed. It will not apply where the unit has been used commercially.

Warranty service is available through your local authorized service dealer or distributor. UNDER NO CIRCUMSTANCES WILL THE RETURN OF A COMPLETE UNIT BE ACCEPTED BY THE FACTORY UNLESS PRIOR WRITTEN PERMISSION HAS BEEN EXTENDED.

SAFETY RULES

Your rotary mower is a precision piece of power equipment, not a plaything. Therefore exercise extreme caution at all times.

1. Remove all sticks, stones, wire and other hazardous items from lawn before mowing. Such items are dangerous to both the mower and individuals in the vicinity of the mower.
2. Always disconnect spark plug cable during repairs or refueling operations.
3. Always start engine from side opposite discharge chute.
4. NEVER place hands or feet under mower or near discharge chute while engine is running.
5. Do not tilt mower at extreme angle while engine is running. Cut grass on hills and banks sideways, not up and down.
6. Always stop engine when not cutting grass.
7. Do not fill gas tank while engine is running. Do not spill gasoline on hot engine.
8. Keep children and pets away from area at all times during mowing operation. Never allow mower to discharge grass toward any person.
9. Do not attempt to start engine while mower is resting in high grass.
10. Check all nuts and bolts, particularly the blade bolts, for tightness. This is especially important during the initial operation period. Make this same check periodically thereafter.

NOTE: Should excessive vibration develop, check your blade and crankshaft immediately. Do not operate mower with an unbalanced blade, a damaged blade or a damaged crankshaft.

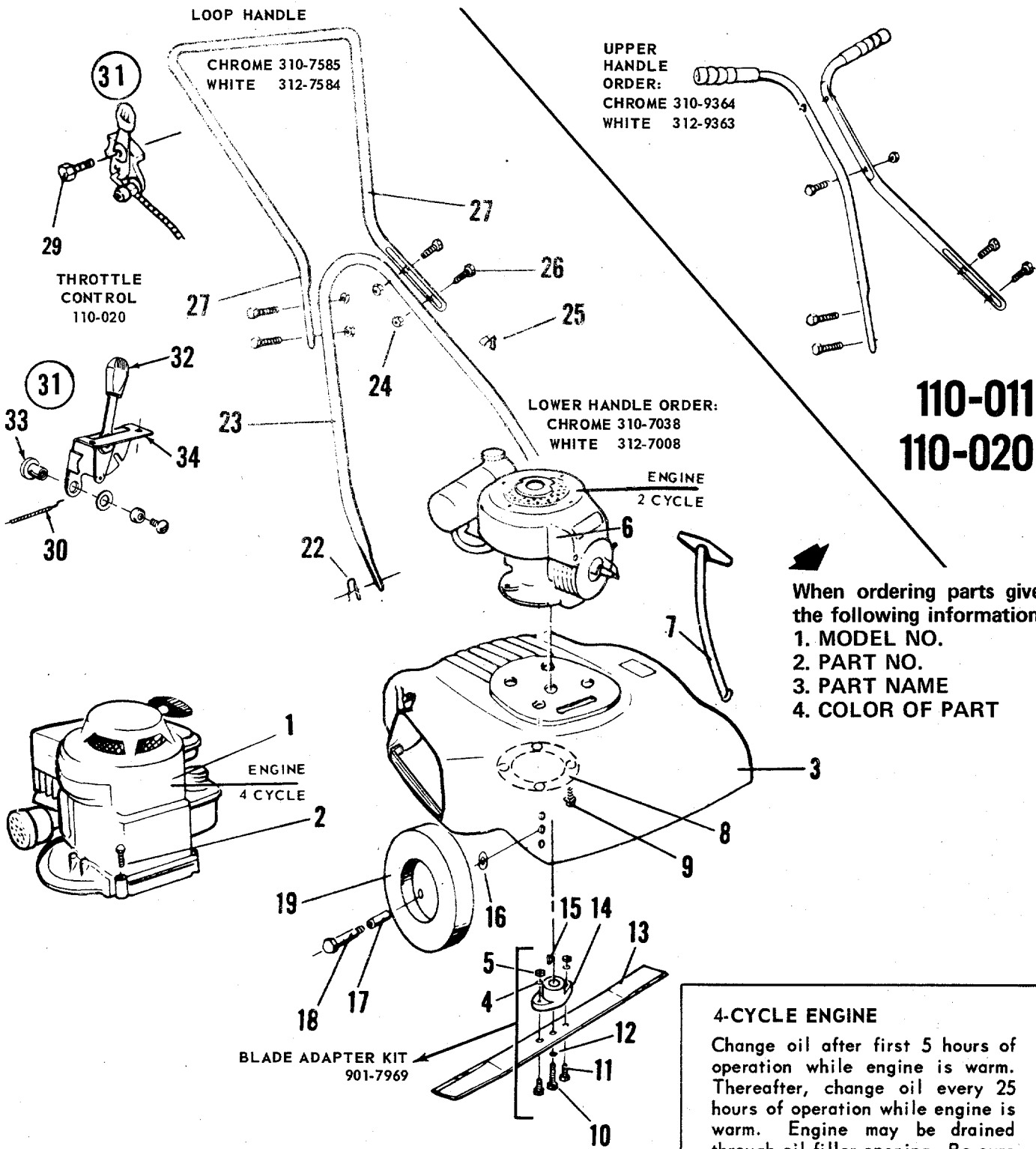

110-011
110-020

When ordering parts give the following information:
 1. MODEL NO.
 2. PART NO.
 3. PART NAME
 4. COLOR OF PART

4-CYCLE ENGINE

Change oil after first 5 hours of operation while engine is warm. Thereafter, change oil every 25 hours of operation while engine is warm. Engine may be drained through oil filler opening. Be sure to replace drain plug and oil filler cap.

OIL FILLER PLUG

When ordering replacement parts, be sure to specify your mower model number, part number, description of part, and the number of parts required . . . Parts and service should be handled by your nearest authorized service firm as recommended by your dealer. Request for parts and service received at the factory will be forwarded to the appropriate Central Service Distributor in your area for handling.

PARTS LIST FOR MOWER MODELS 110-011 and 110-020

Illus. No.	110-011 Part No.	110-020 Part No.	DESCRIPTION
1	—	4 cycle	Engine
2	—	710-158	Hex Head Cap Screw 5/16-24 x 1-1/4 long *
3	414-10097	414-10096	Deck Assembly
4	736-119	736-119	Spring Lockwasher for 5/16 Screw *
5	712-123	712-123	Hex Nut 5/16-24 Thread *
6	2 cycle	—	Engine
7	752-103	—	Rope Starter
8	310-7092	—	Reinforcement Plate
9	710-198	—	Sems Cap Screw 5/16-18 x 3/4 long *
10	710-113	710-113	Hex Head Cap Screw 3/8-24 x 1-5/8 long - Heat Treated
11	710-117	710-117	Hex Head Cap Screw 5/16-24 x 1 long - Heat Treated
12	736-169	736-169	Spring Lockwasher for 3/8 Screw *
13	312-7713	312-7713	Blade - 18 inch
14	748-100	748-100	Blade Adapter
15	714-365	714-365	Hi Pro Key H. P. 505 *
16	736-105	736-105	Belleville Washer for 3/8 Screw
17	305-7006	305-7006	Fortiflex Bearing
18	738-213	738-213	Axle Bolt
19	501-8306	501-8306	Wheel Assembly (Includes Tire and Bearing)
22	714-507	714-507	Cotter Pin 3/4 long *
23	312-7008	312-7008	Lower Handle
24	712-107	712-107	Hex Center Lock Nut 1/4-20 Thread *
25	—	746-145	Cable Clip for 3/4 tubing
26	710-106	710-106	Hex Head Cap Screw 1/4-20 x 1-1/4 long *
27	312-7584	312-7584	Upper Handle
29	—	710-606	Hex Head Cap Screw 1/4-20 x 1-1/2 long *
30	—	732-139	Control Conduit and Wire ‡
31	—	310-8846	Control - Throttle (Complete)
32	—	305-7470	Control Knob ‡
33	—	901-7627	Ferrule Assembly (Complete) ‡
34	—	310-8841	Control Bracket Assembly ‡
	901-7969	901-7969	Blade Adapter Kit (Blade NOT Included)

‡ Part of Control Throttle Complete.

* For faster service obtain standard nuts, bolts, and washers locally. If these items cannot be obtained locally, order by part number and size as shown on parts list.

NOTE: This instruction manual covers various models and all accessories shown do not necessarily apply to your model mower.

MTD PRODUCTS INC extends its warranty only on the mower. If repairs or service is needed on the engine, please contact your nearest authorized engine service outlet. Check the "Yellow Pages" of your telephone book under "Engines--Gasoline".



ASSEMBLY

Your new mower is shipped preassembled with the exception of the handle.

1. Remove lawn mower and all parts from the carton. Make certain that all loose parts and literature have been removed before the carton is discarded.
2. If mower is equipped with throttle control (two cycle engines are constant speed engines and require no throttle control) extend throttle control assembly which is attached to engine at the rear of the mower and place on the floor. CAUTION: Do not bend or kink control wires.
3. Assemble the upper and lower handle parts with cap screws and locknuts provided in parts bag. On mower Model 110-020 use the longer (yellow) screw to attach throttle control.
4. Holes at the bottom of the lower handle are to be fitted over studs located in front of each rear wheel mounting position.
5. Secure throttle control wire to lower right handle with cable clips.
6. Check blade bolts for proper tightness.

OPERATION

For shipping purposes, the wheels on your mower are generally set in the upper mounting holes. Relocating the wheels to the second holes from the bottom will give better mowing results in most cases. When changing wheel positions, be sure Belleville washers are assembled properly. (See cutting height instructions.)

1. Service engine with gas and oil. See engine manual packed with lawn mower for complete instructions for the care and maintenance of engine. READ DIRECTIONS CAREFULLY.
2. When ready to start engine, place throttle control lever on handle in "START" position and start engine in accordance with instructions in engine manual. After engine starts, move throttle control lever on handle to desired engine speed. The engine is stopped by placing control lever on handle in the "STOP" position.

Two cycle engines are constant speed engines. No throttle control is required. The engine is stopped by moving the spark plug shorting lever against the tip of the spark plug. Be sure this is moved away before starting the engine.

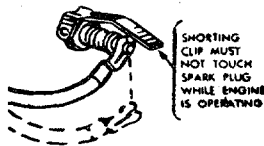

3. Be sure that lawn is clear of stones, sticks, wire or other objects which could damage lawn mower or engine. For best results and to insure more even grass distribution, do not mow when lawn is excessively wet.

ADJUSTMENTS

CAUTION: Do not at any time make any adjustment to lawn mower without first stopping engine and disconnecting spark plug wire.

CUTTING HEIGHT

Adjustment may be made by removing and moving wheel studs to desired position. Cutting heights will be raised as wheel studs are moved to a lower hole and lowered as wheel studs are moved to a higher hole in the deck. All wheel studs must be mounted in a relative position to the deck.

THROTTLE

If adjustment becomes necessary, the throttle control wire assembly can be reset as follows:

1. Loosen, but do not remove, screw securing throttle control wire assembly at engine.
2. Move throttle control lever on handle to "FAST" position.
3. Move lever, to which control wire is fastened at engine, to full open position and retighten screw to secure throttle control wire assembly.

LUBRICATION

IMPORTANT: Always stop engine and disconnect spark plug wire before cleaning, lubricating or doing any kind of work on lawn mower.

WHEELS - Wheel bearings are of lifetime Fortiflex. They require no lubrication.

THROTTLE - Periodically lubricate throttle control lever and throttle wire assembly with a few drops of light oil (S.A.E. No. 10 or 20) for ease of operation.

ENGINE - Follow engine manual for lubrication instructions.

MAINTENANCE

CUTTING BLADE: The blade may easily be removed for grinding or replacement as follows:

1. Remove bolt and lock washer holding blade and hub assembly to engine crankshaft.
2. Remove blade and hub assembly from engine crankshaft.
3. Remove two bolts, lock washers and nuts holding blade to blade hub.

When sharpening blade, follow the original angle of grind as a guide. It is extremely important that each cutting edge receives an equal amount of grinding to prevent an unbalanced blade. An unbalanced blade will cause excessive vibration when rotating at high speeds and may cause damage to the mower.

Upon reassembly, make certain all parts are assembled properly and tightened securely.

DECK - The underside of mower deck should be cleaned after each period of use as grass clippings, leaves, dirt and other matter will accumulate. This accumulation of grass clippings, etc., is undesirable as it will invite rust and corrosion and may cause an uneven discharge of grass clippings at the next cutting.

The deck may be cleaned by tilting the mower forward or on its left side and scraping clean with a suitable tool or by washing with a stream of water from a garden hose. CAUTION: Do not direct the stream of water at a hot engine as damage to the engine may result.

STORAGE - The following steps should be taken to prepare lawn mower for storage.

1. Clean and lubricate mower thoroughly as described in the preceding instructions.
2. Refer to engine manual for correct engine storage instructions.
3. Coat mower's cutting blade with chassis grease to prevent rusting.
4. Place blocks under deck to raise tires clear of floor.
5. Store mower in a dry, clean area.

USING YOUR ROTARY MOWER

For the best results do not cut wet grass because it tends to stick to the underside of the mower, thus preventing proper discharge of grass clippings. If wet grass must be cut, reduce engine speed and walking speed to help distribute the clippings more effectively.

New grass should be treated as wet grass, otherwise a normal walking speed is about the right pace for efficient mowing.

The best mowing pattern is one that allows the clippings to discharge towards the uncut part of the lawn. This permits recutting of the clippings to further pulverize them. When cutting high weeds, discharge towards cut portion then recut at right angles to first direction.

Lawn should be cut in the fall as long as there is growth.