

\$1.00

OWNER'S GUIDE

ASSEMBLY • OPERATION • MAINTENANCE • PARTS



(Model 093R Shown)

20" MULCHING ROTARY MOWER

Model Numbers

111-093R000

111-094R000

111-095R000

111-096R000

111-098R000

Important: Read Safety Rules and Instructions Carefully



Made
in
AMERICA

WARNING: This unit is equipped with an internal combustion engine and should not be used on or near any unimproved forest-covered, brush-covered or grass-covered land unless the engine's exhaust system is equipped with a spark arrester meeting applicable local or state laws (if any). If a spark arrester is used, it should be maintained in effective working order by the operator.

In the State of California the above is required by law (Section 4442 of the California Public Resources Code). Other states may have similar laws. Federal laws apply on federal lands. A spark arrester for the muffler is available through your nearest engine authorized service dealer or contact the service department, P.O. Box 360900, Cleveland, Ohio 44136.

IMPORTANT

RULES FOR SAFE OPERATION



THIS SYMBOL POINTS OUT IMPORTANT SAFETY INSTRUCTIONS WHICH, IF NOT FOLLOWED, COULD ENDANGER THE PERSONAL SAFETY AND/OR PROPERTY OF YOURSELF AND OTHERS. READ AND FOLLOW ALL INSTRUCTIONS IN THIS MANUAL BEFORE ATTEMPTING TO OPERATE YOUR LAWN MOWER. FAILURE TO COMPLY WITH THESE INSTRUCTIONS MAY RESULT IN PERSONAL INJURY. WHEN YOU SEE THIS SYMBOL—



HEED ITS WARNING.



DANGER:

Your lawn mower was built to be operated according to the rules for safe operation in this manual. As with any type of power equipment, carelessness or error on the part of the operator can result in serious injury. If you violate any of these rules, you may cause serious injury to yourself or others.



TRAINING

1. Read this owner's guide carefully in its entirety before attempting to assemble or operate this machine. Be completely familiar with the controls and the proper use of this machine before operating it. Keep this manual in a safe place for future and regular reference and for ordering replacement parts.
2. Your rotary mower is a precision piece of power equipment, not a plaything. Therefore, exercise extreme caution at all times. Your unit has been designed to perform one job: to mow grass. Do not use it for any other purpose.
3. Never allow children under 14 years old to operate a power mower. Children 14 years old and over should only operate mower under close parental supervision. Only persons well acquainted with these rules of safe operation should be allowed to use your mower.
4. Keep the area of operation clear of all persons, particularly small children and pets. Stop engine when they are in the vicinity of your mower to help prevent blade contact or throw object injury. Although the area of operation should be completely cleared of foreign objects, an object may have been overlooked and could be accidentally thrown by the mower in any direction and cause serious personal injury to the operator or any others allowed in the area.



PREPARATION

1. Thoroughly inspect the area where the equipment is to be used. Remove all stones, sticks, wire, bones and other foreign objects which could be picked up and thrown by the mower in any direction and cause serious personal injury to the operator or any others allowed in the area. Plan your mowing pattern to avoid discharge of material toward roads, sidewalks, bystanders and the like.
2. Always wear safety glasses or eye shields during operation or while performing an adjustment or repair, to protect eyes from foreign objects that may be thrown from the machine in any direction.
3. Wear sturdy, rough-soled work shoes and close-fitting slacks and shirts. Shirts and pants that cover the arms and legs and steel-toed shoes are recommended. Do not wear loose fitting clothes or jewelry. They can be caught in moving parts. Never operate a unit in bare feet, sandals, or sneakers.
4. Before working with gasoline, extinguish all cigarettes, cigars, pipes and other sources of ignition. Check the fuel level before starting the engine. Gasoline is an extremely flammable fuel. Do not fill the gasoline tank indoors, while the engine is running, or until engine has been allowed to cool for at least two minutes after running. Replace gasoline cap securely and wipe off any spilled gasoline before starting the engine as it may cause a fire or explosion.
5. Disengage the self-propelled mechanism or drive clutch on units so equipped before starting the engine.
6. The blade control handle is a safety device. Never attempt to bypass its operation. Doing so makes the safety device inoperative and may result in personal injury through contact with the rotating blade. The blade control handle must operate easily in both directions and automatically return to the disengaged position when released.
7. Never attempt to make a wheel or cutting height adjustment while the engine is running.
8. Never operate the mower in wet grass. Always be sure of your footing. A slip and fall can cause serious personal injury. Keep a firm hold on the handle and walk, never run. Mow only in daylight or in good artificial light.



OPERATION

1. Do not change the engine governor settings or overspeed the engine. Excessive engine speeds are dangerous.
2. Do not put hands or feet near or under rotating parts. Keep clear of the discharge opening at all times as the rotating blade can cause injury.
3. Stop the blade when crossing gravel drives, walks or roads.
4. After striking a foreign object, stop the engine, remove the wire from the spark plug, and thoroughly inspect the mower for any damage. Repair the damage before restarting and operating the mower.
5. If the equipment should start to vibrate abnormally, stop the engine and check immediately for the cause. Vibration is generally a warning of trouble.
6. Shut the engine off and wait until the blade comes to a complete stop before removing the grass catcher or unclogging the chute. The cutting blade continues to rotate for a few seconds after engine is shut off. Never place any part of the body in the blade area until you are sure the blade has stopped rotating.
7. Before cleaning, repairing or inspecting, make certain the blade and all moving parts have stopped. Disconnect the spark plug wire, and keep the wire away from the spark plug to prevent accidental starting.
8. Do not run the engine indoors.
9. Never cut grass by pulling mower toward you. Mow across the face of slopes, never up-and-down. Exercise extreme caution when changing direction on slopes. Do not mow excessively steep slopes. Always be sure of your footing. A slip and fall can cause serious personal injury.
10. Never operate mower without proper guards, plates or other safety protective devices in place.
11. Muffler and engine become hot and can cause a burn. Do not touch.



MAINTENANCE AND STORAGE

1. Check the blade and engine mounting bolts at frequent intervals for proper tightness. Also visually inspect blade for damage (e.g. bent, cracked). Replace with blade which meets original equipment specifications.
2. Keep all nuts, bolts, and screws tight to be sure the equipment is in safe working condition.
3. Never store the mower with gasoline in the tank or gas containers inside of a building where fumes may reach an open flame or spark (e.g. gas hot water heater). Allow the engine to cool before storing in any enclosure.
4. To reduce fire hazard, keep the engine free of grass, leaves and excessive oil.
5. Check the grass catcher bag frequently for wear or deterioration. Replace a worn or damaged bag immediately. For safety protection, replace only with new bag meeting original equipment specifications.

USE THIS SHEET AS A GUIDE TO DETERMINE SLOPES WHERE YOU MAY NOT OPERATE SAFELY.

SLOPE GAUGE

(Keep this sheet in a safe place for future reference.)

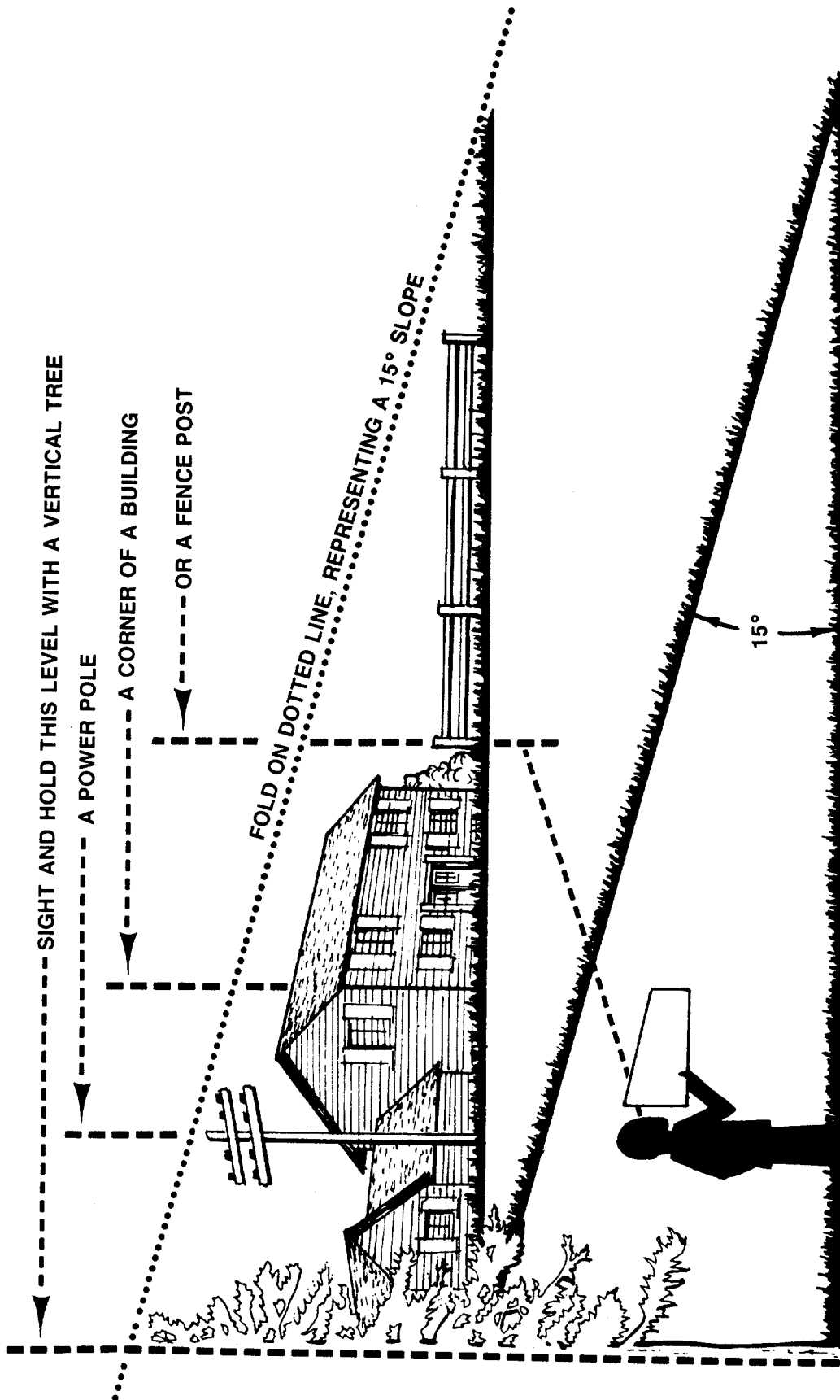

Do not mow on inclines with a slope in excess of 15 degrees (a rise of approximately 2½ feet every 10 feet). A riding mower could overturn and cause serious injury. If operating a walk-behind mower on such a slope, it is extremely difficult to maintain your footing and you could slip, resulting in serious injury.

Operate RIDING mowers up and down slopes, never across the face of slopes.
Operate WALK-BEHIND mowers across the face of slopes, never up and down slopes.

CONTENTS OF HARDWARE PACK/PARTS IDENTIFICATION

Remove this sheet from your owner's manual and lay the hardware on the illustration for identification purposes. After assembly, keep the Slope Gauge which is on the reverse side of this sheet for future use. (Hardware pack may contain extra items which are not used on your unit. Part numbers are shown in parentheses.)

A ATTACHING THE LOWER HANDLE

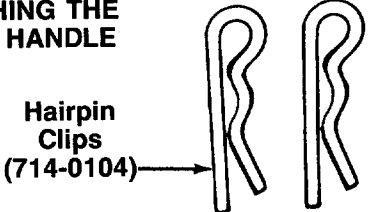

Hairpin Clips (714-0104)

B ATTACHING THE UPPER HANDLE

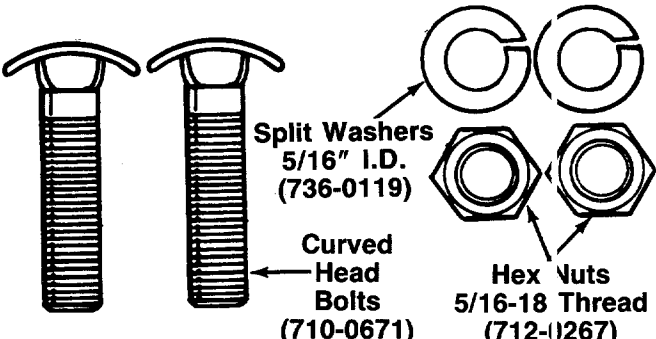

Split Washers 5/16" I.D. (736-0119)

Curved Head Bolts (710-0671)

Hex Nuts 5/16-18 Thread (712-0267)

C ATTACHING THE STARTER ROPE

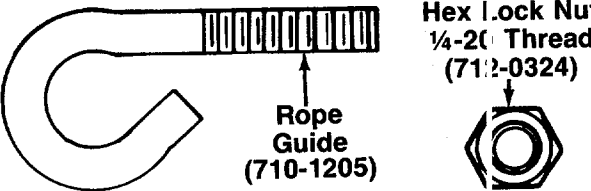

Rope Guide (710-1205)

Hex Lock Nut 1/4-20 Thread (712-0324)

D ATTACHING THE THROTTLE CONTROL

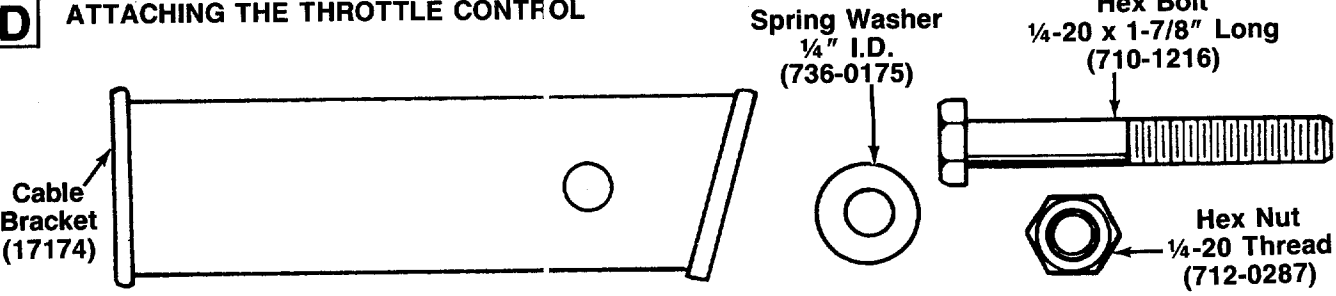

Cable Bracket (17174)

Spring Washer 1/4" I.D. (736-0175)

Hex Bolt 1/4-20 x 1-7/8" Long (710-1216)

Hex Nut 1/4-20 Thread (712-0287)

E SECURING THE CABLES

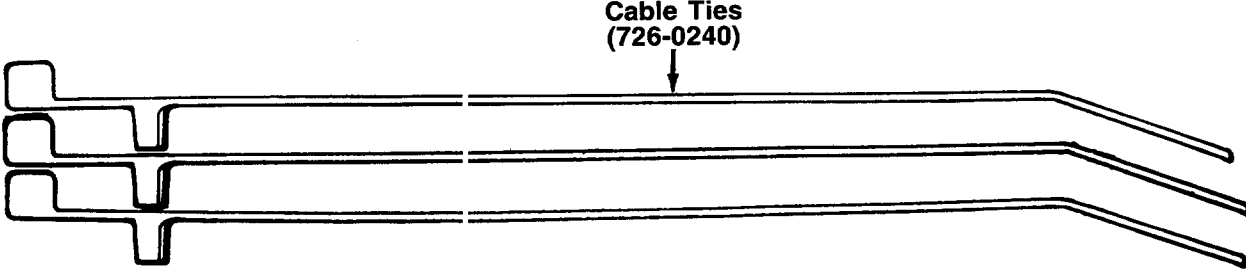

Cable Ties (726-0240)

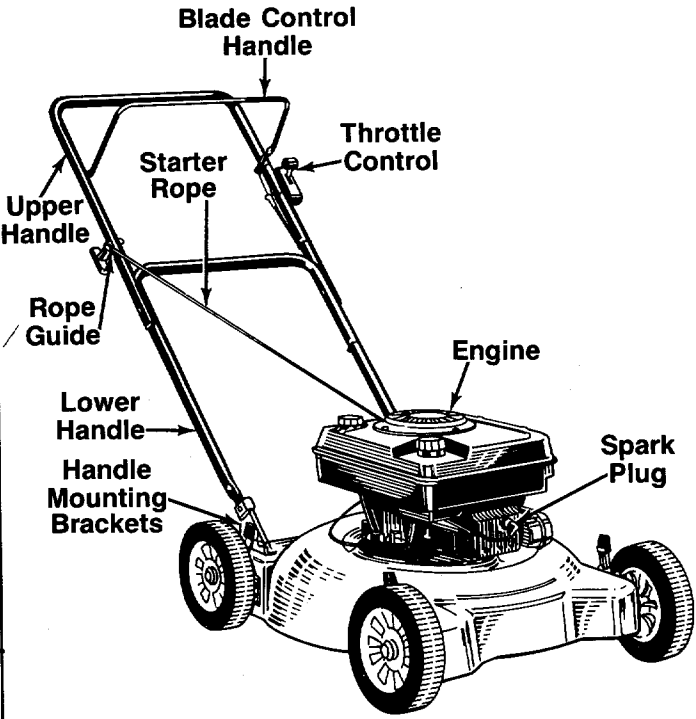

PARTS IDENTIFICATION

Cut Along This Line



ASSEMBLY INSTRUCTIONS

IMPORTANT: This unit is shipped **WITHOUT GASOLINE or OIL**. After assembly, service engine with gasoline and oil as instructed in the separate engine manual packed with your unit.

NOTE: Reference to right or left hand side of the mower is observed from the operating position. Refer to parts identification on page 4 for location of parts when assembling the mower.

Tools Required for Assembly

- (1) Pair of Pliers
- (1) 1/2" Wrench or Adjustable Wrench
- (2) 7/16" Wrenches or Adjustable Wrenches
- (1) Flat Bladed Screwdriver

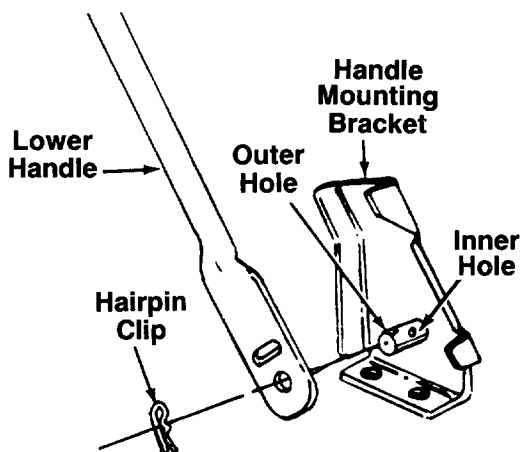

FIGURE 1.

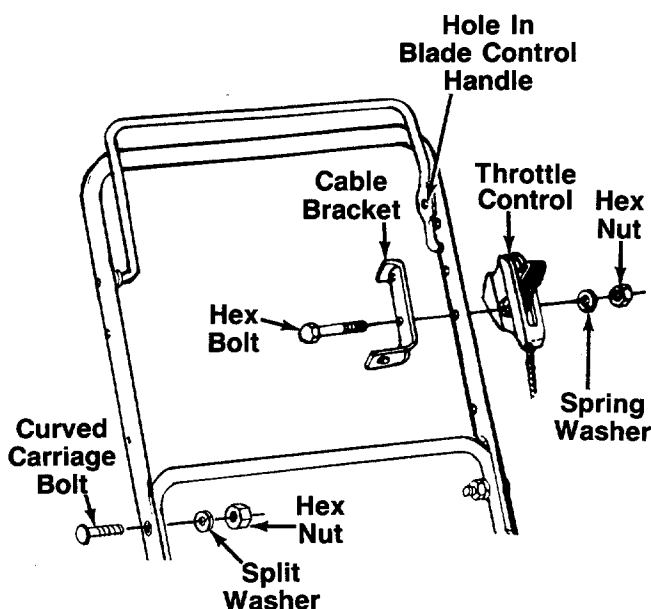

FIGURE 2.

UNPACKING

1. Remove the lawn mower from the carton by opening the top flaps and lifting the unit out. Be careful of the staples. Make certain all parts and literature have been removed from the carton before the carton is discarded.
2. Disconnect and ground the spark plug wire against the engine.
3. Stretch out all control cables and place on the floor. Be careful not to bend or kink the cables at any time during assembly.
4. Remove page four from this manual and lay the contents of the hardware pack on the illustration for identification.

ATTACHING THE LOWER HANDLE (Hardware A)

1. Attach the lower handle by placing the bottom holes in the lower handle over the weld pins on the handle mounting brackets extending through the rear of the deck.
2. Using a pair of pliers, squeeze one leg of the lower handle against the handle mounting bracket. Insert the hairpin clip into the hole in the weld pin. See figure 1. Repeat on other side.

ATTACHING THE UPPER HANDLE (Hardware B)

1. Place the upper handle in position over the lower handle. The hole in the side of the blade control handle (attached to the upper handle) must be on the **left** side.
2. Secure the upper handle to lower handle using the curved head bolts, split washers and hex nuts as shown in figure 2.

ATTACHING THE THROTTLE CONTROL (Hardware D)

The throttle control is attached to the engine. Attach the throttle control to the **left** side of upper handle as follows. See figure 2.

1. Route the throttle control cable inside the legs and beneath the upper bar of the lower handle.
2. Place cable bracket against left side of upper handle, lining up the hole in the bracket with the bottom hole in upper handle. Place 1/4" hex bolt through cable bracket and handle, from the inside to the outside.
3. Place throttle control on the hex bolt (outside of upper handle), with the throttle lever facing upward. Secure with spring washer (cupped side against the throttle control) and hex nut.

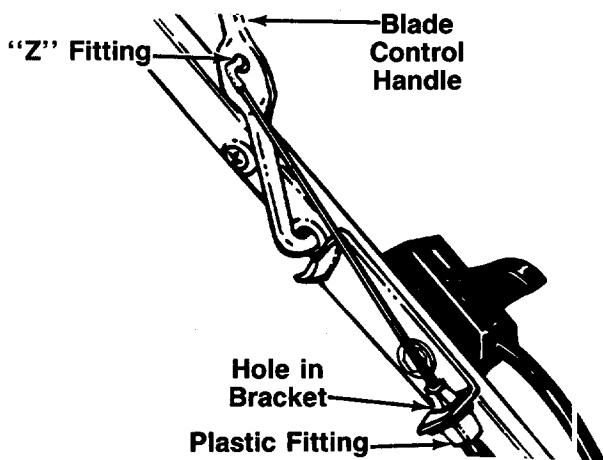

FIGURE 3.

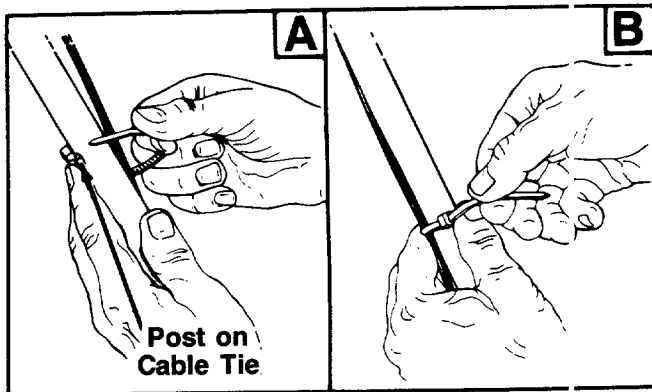

FIGURE 4.

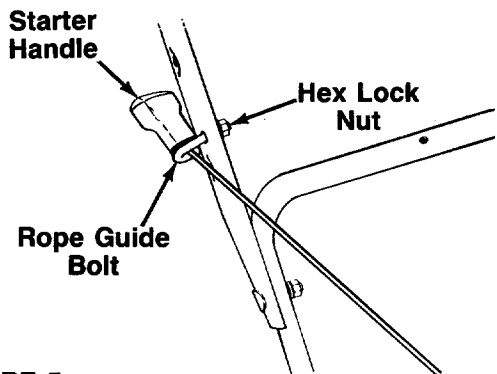

FIGURE 5.

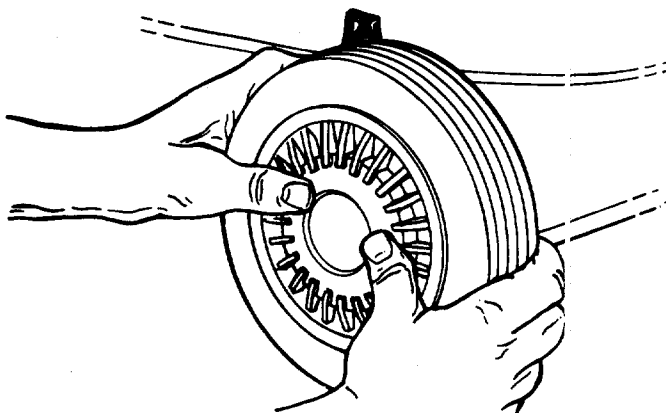

FIGURE 6.—5 1/2" Diameter Hub Cap Shown

ATTACHING THE BRAKE CABLE

1. The brake cable is attached to the engine, and has a "Z" fitting on the loose end. Route the brake cable below the lower handle. Place end of cable through the hole in the bracket as shown in figure 3.
3. Be careful not to bend or kink the cable at any time. Push the plastic fitting until it locks into the hole in the bracket.



WARNING: Brake cable must be assembled as shown for proper blade brake operation.

2. Hook the "Z" end of the brake cable into the hole in the blade control handle from the inside to the outside as shown in figure 3.

SECURING THE CABLES (Hardware E)

Secure all cables to the left side of the handle as follows.



WARNING: When attaching the control cables, the cables must be routed to avoid contact with all sharp edges and hot surfaces to prevent damage to the cables, which will render the controls inoperative.

1. Insert posts on cable ties into holes provided on the handles, one on the upper handle and two on the lower handle. The holes may be either on the inside or outside of the handles. See figure 4A.
2. Secure the cables with the cable ties. See figure 4B.
3. Trim excess ends of cable ties.

ATTACHING THE STARTER ROPE (Hardware C)

1. The starter rope is inside the top of the engine. Additional rope may be wound around the starter handle. If so, unwind the rope from the handle.
2. With the spark plug wire disconnected and grounded, depress the blade control handle and pull the rope out of the engine.
3. Place the rope guide around the starter handle, so the rope guide bends downward as shown in figure 5. Insert the rope guide into the handle, and secure with hex lock nut.

FINAL ASSEMBLY OF MOWER

1. Place hub caps in position against the inner hub of the wheel. To install 5 1/2" diameter hub caps, press firmly around the center portion of hub cap in a circular motion, similar to installing a lid on a round, plastic container. See figure 6. The hub caps are flexible and will snap over wheel hubs.

NOTE: It may be helpful to place the hub caps in hot tap water for several minutes to make them pliable before installing, especially if the temperature is less than 60°F.

2. Make certain all nuts and bolts are tightened securely.

CONTROLS

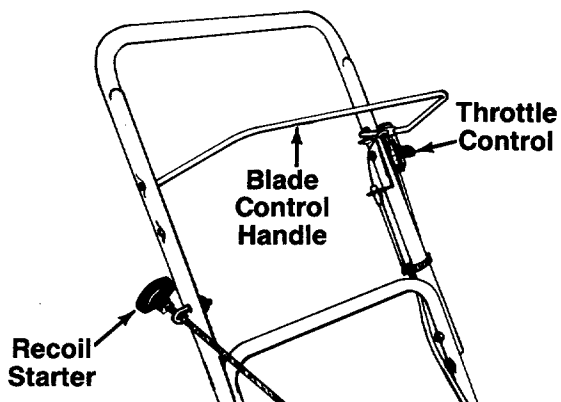

FIGURE 7.

BLADE CONTROL HANDLE



WARNING: This control mechanism is a safety device. Never attempt to bypass its operations.

The blade control handle is located on the upper handle of the mower. See figure 7. The blade control handle must be depressed in order to operate the unit. Release the blade control handle to stop the engine and blade.



WARNING: The blade will be rotating whenever the engine is running.

THROTTLE CONTROL

The throttle control is located on the side of the upper handle. It is used to regulate the engine speed.



WARNING: The throttle control cannot be used to stop the engine.

RECOIL STARTER

The recoil starter handle is attached to the handle. See figure 7. Stand behind the unit in the operating position to start the unit.

OPERATION



FIGURE 8.

Keep hands and feet away from the mowing deck. See figure 8.

The operation of any lawn mower can result in foreign objects being thrown into the eyes, which can result in severe eye damage.



Always wear safety glasses or eye shields. We recommend wide vision safety mask for over spectacles or standard safety glasses.

NOTE: For shipping purposes your mower is set with the wheels in a low cutting height position. For best results raise the cutting position until it is determined which height is best for your lawn. See cutting height adjustment section.

GAS AND OIL FILL-UP

Service the engine with gasoline and oil as instructed in the separate engine manual packed with your mower. Read instructions carefully.



WARNING: Never fill fuel tank indoors, with engine running or until the engine has been allowed to cool for at least two minutes after running.

TO START ENGINE AND ENGAGE BLADE

1. Attach spark plug wire to spark plug. Make certain the metal loop on the end of the spark plug wire (inside the rubber boot) is fastened securely over the metal tip on the spark plug. See figure 9.

Metal Loop on Spark Plug Wire

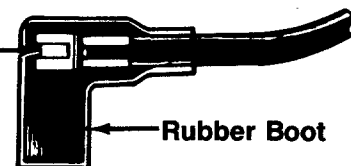

FIGURE 9.

2. Open fuel shut-off valve if unit is so equipped. Refer to separate engine manual.
3. Move throttle control lever all the way forward.
4. **Tecumseh engines only:** Prime engine as instructed in the separate engine manual packed with your unit.
5. Standing behind the unit, depress the blade control handle and hold it against the upper handle as shown. See figure 10.
6. Grasp the recoil starter handle and pull back rapidly, extending rope fully. Return it slowly to the rope guide bolt.
7. After engine starts, move throttle control to desired engine speed.

NOTE: If any problems are encountered, refer to the Trouble Shooting Guide on page 11.

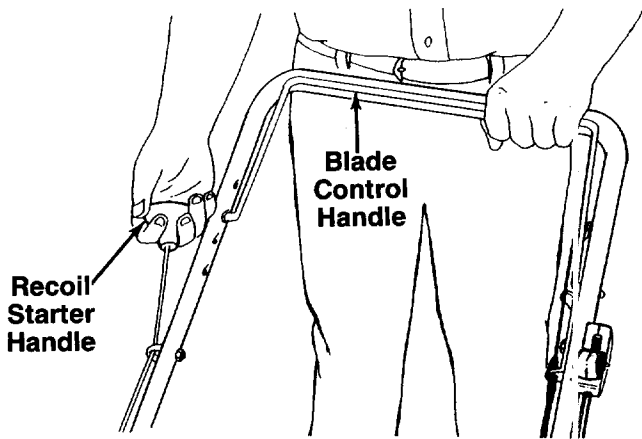

FIGURE 10.

TO STOP ENGINE AND BLADE

1. Release the blade control handle to stop the engine and blade.



WARNING: The blade continues to rotate for a few seconds after the engine is shut off.

2. Disconnect the spark plug wire and ground it against the engine to prevent accidental starting while equipment is unattended.

USING YOUR ROTARY MOWER

Be sure that lawn is clear of stones, sticks, wire, or other objects which could damage lawn mower or engine. Such objects could be accidentally thrown by the mower in any direction and cause serious personal injury to the operator and others.

For the best results, do not cut wet grass because it tends to stick to the underside of the mower, preventing proper mulching of grass clippings. In addition, wet grass could cause you to slip and fall. New grass, thick grass or wet grass may require a narrower cut.

For best results, cut off one-third or less of the total length of the grass. Lawn should be cut in the fall as long as there is growth.

This mower is designed to be operated at full throttle to give you the best cut and do the most effective job of mulching.



WARNING: If you strike a foreign object, stop the engine. Remove wire from spark plug, thoroughly inspect the mower for any damage, and repair the damage before restarting and operating the mower. Extensive vibration of the mower during operation is an indication of damage. The unit should be promptly inspected and repaired.

ADJUSTMENTS



WARNING: Do not at any time make any adjustment to lawn mower without first stopping engine and disconnecting spark plug wire.

CUTTING HEIGHT ADJUSTMENT

An adjusting plate and thumb lever at each wheel position provides cutting height adjustment. Each adjusting plate has nine height positions. Height of cut will be changed when the thumb lever is moved from one hole to another. Simply depress the lever towards wheel and move wheel and lever assembly to desired position. All wheels must be placed in the same relative position. See figure 11.

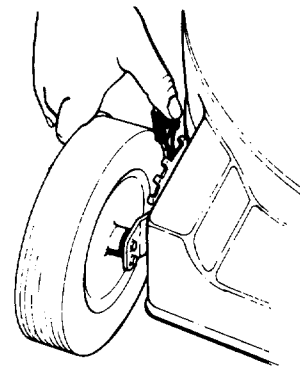

FIGURE 11.

THROTTLE CONTROL ADJUSTMENT

If the throttle control requires adjustment or has been replaced, adjust as follows.

1. Remove the screw shown in figure 12. Remove the cable clamp from the cable.
2. Push the throttle control lever on the handle all the way forward to CHOKE or START position. Make certain the throttle control lever remains in this position.
3. Push the control lever on the engine as far toward the rear of the engine as it will go. Secure the cable in this position with the cable clamp and screw.

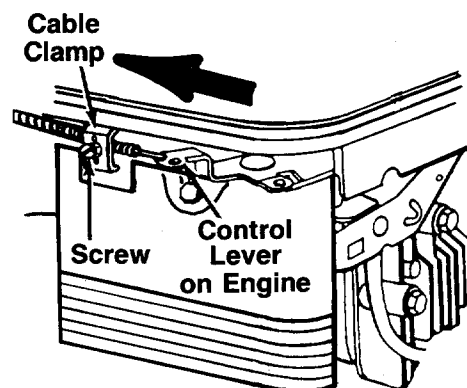

FIGURE 12A.—Briggs & Stratton Quantum Engine

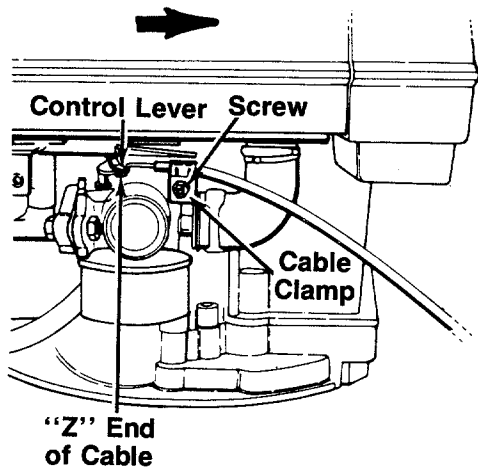

FIGURE 12B.—Tecumseh Premier Engine

CARBURETOR ADJUSTMENTS



WARNING: If any adjustments are made to the engine while the engine is running (e.g. carburetor), keep clear of all moving parts. Be careful of heated surfaces and muffler.

Minor carburetor adjustments may be required to compensate for differences in fuel, temperature, altitude and load. To adjust carburetor, refer to the separate engine manual packed with your mower.

NOTE: A dirty air cleaner will cause an engine to run rough. Be certain air cleaner is clean and attached to the carburetor before adjusting carburetor. Refer to the separate engine manual.

LUBRICATION



WARNING: Always stop engine and disconnect spark plug wire before cleaning, lubricating or doing any kind of work on lawn mower.

Blade Control—Lubricate the pivot points on the blade control handle and the brake cable at least once a season with light oil. See figure 13. The blade control must operate freely in both directions.

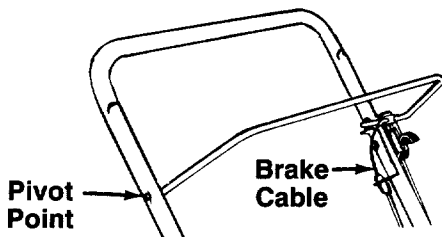

FIGURE 13.

Wheels—Mower may be provided with ball bearing wheels. Lubricate at least once a season with light oil. Also, if the wheels are removed for any reason, lubricate the surface of the axle bolt and the inner surface of the wheel with light oil. A 4 oz. plastic bottle of light oil lubricant is available. Order part number 737-0170. Engine oil may also be used.

Engine—Follow engine manual for lubrication instructions.

Throttle—Periodically lubricate throttle control lever and throttle wire assembly with a few drops of light oil for ease of operation.

MAINTENANCE



WARNING: Be sure to disconnect and ground the spark plug wire before performing any repairs or maintenance.

NOTE: When tipping the unit, empty the fuel tank and keep engine spark plug side up.

TROUBLE SHOOTING

Refer to page 11 of this manual for trouble shooting information.

CUTTING BLADE

When removing the cutting blade for sharpening or replacement, protect hands by using heavy gloves or a rag to grasp the cutting blade. Remove the bolt and bell washer which hold the blade and adapter to the engine crankshaft. Remove the blade and adapter from the crankshaft.

If the blade or blade adapter needs replacing, remove the two small bolts, lock washers and nuts which hold the blade to the adapter.



WARNING: Periodically inspect the blade adapter for cracks, especially if you strike a foreign object. Replace when necessary.

When sharpening the blade, follow the original angle of grind as a guide. It is **extremely important** that each cutting edge receives an equal amount of grinding to prevent an unbalanced blade. An unbalanced blade will cause excessive vibration when rotating at high speeds, may cause damage to the mower and could break, causing personal injury.

It is recommended that the blade always be removed from the adapter for the best test of balance. The blade can be tested by balancing it on a round shaft screwdriver. Remove metal from the heavy side until it balances evenly.

Before reassembling the blade and the blade adapter to the unit, lubricate the engine crankshaft and the inner

surface of the blade adapter with light oil. Lubricating the bolt holes, bolts and inner surface of the nuts with light oil is also recommended. A 4 oz. plastic bottle of light oil lubricant is available. Order part number 737-0170. Engine oil may also be used.

When replacing the blade, be sure to install the blade with the side of the blade marked "Bottom" (or with part number) facing the ground when the mower is in the operating position.

Blade Mounting Torque

Center Bolt and Blade Adapter Bolts: 375 in. lb. min., 450 in. lb. max.

To insure safe operation of your unit, **all** nuts and bolts must be checked periodically for correct tightness.

DECK

The underside of the mower deck should be cleaned after each use to prevent a buildup of grass clippings, leaves, dirt or other matter. If this debris is allowed to accumulate, it will invite rust and corrosion, and may prevent proper mulching.

The deck may be cleaned by tilting the mower and scraping clean with a suitable tool (make certain the spark plug wire is disconnected).

ENGINE

Refer to the separate engine manual for engine maintenance instructions.

Maintain **engine oil** as instructed in the separate engine manual packed with your unit. Read and follow instructions carefully.

Service **air cleaner** every 25 hours under normal conditions. Clean every few hours under extremely dusty conditions. Poor engine performance and flooding usually indicates that the air cleaner should be serviced. To service the air cleaner, refer to the separate engine manual packed with your unit.

The **spark plug** should be cleaned and the gap reset once a season. Spark plug replacement is recommended at the start of each mowing season; check engine manual for correct plug type and gap specifications.

Clean the engine regularly with a cloth or brush. Keep the cooling system (blower housing area) clean to permit proper air circulation which is essential to engine performance and life. Be certain to remove all grass, dirt and combustible debris from muffler area.

OFF-SEASON STORAGE

The following steps should be taken to prepare lawn mower for storage.

1. Clean and lubricate mower thoroughly as described in the lubrication instructions.
2. Refer to engine manual for correct engine storage instructions.
3. Coat mower's cutting blade with chassis grease to prevent rusting.
4. Store mower in a dry, clean area.

NOTE: *When storing any type of power equipment in an unventilated or metal storage shed, care should be taken to rust-proof the equipment. Using a light oil or silicone, coat the equipment, especially cables and all moving parts.*

HANDLE STORAGE

The handle may be placed in an upright position for storage. Press inward on the bottom of the lower handle and push forward. The handle will lock in this position.

To place the handle in the operating position, remove the starter rope from the rope guide bolt. Grasp the lower handle at the bottom, press inward slightly and tip the handle backward. With the spark plug wire disconnected and grounded, depress the blade control handle and pull the starter rope out from the engine. Slip the starter rope into the rope guide bolt.

TROUBLE SHOOTING GUIDE

Trouble	Possible Cause(s)	Corrective Action
Engine fails to start	<ol style="list-style-type: none"> 1. Blade control handle disengaged. 2. Spark plug wire disconnected. 3. Throttle control lever not in CHOKE or START position. 4. Fuel shut-off valve closed (if so equipped). 5. Fuel tank empty, or stale fuel. 6. Blocked fuel line. 7. Faulty spark plug. 8. Engine flooded. 	<ol style="list-style-type: none"> 1. Engage blade control handle. 2. Connect wire to spark plug. 3. Move throttle lever to CHOKE or START position. 4. Open fuel shut-off valve. 5. Fill tank with clean, fresh gasoline. 6. Clean fuel line. 7. Clean, adjust gap or replace. 8. Remove spark plug, dry the plug, and crank engine with plug removed and throttle in off position. Replace spark plug, connect wire and resume starting procedures.
Engine runs erratic	<ol style="list-style-type: none"> 1. Unit running in CHOKE or START position. 2. Spark plug wire loose. 3. Blocked fuel line or stale fuel. 4. Vent in gas cap plugged. 5. Water or dirt in fuel system. 6. Dirty air cleaner. 7. Carburetor out of adjustment. 	<ol style="list-style-type: none"> 1. Move throttle lever to FAST position. 2. Connect and tighten spark plug wire. 3. Clean fuel line; fill tank with clean, fresh gasoline. 4. Clear vent. 5. Drain fuel tank. Refill with fresh fuel. 6. Clean air cleaner.† 7. Adjust carburetor.†
Engine overheats	<ol style="list-style-type: none"> 1. Engine oil level low. 2. Air flow restricted. 3. Carburetor not adjusted properly. 	<ol style="list-style-type: none"> 1. Fill crankcase with proper oil. 2. Remove blower housing and clean.† 3. Adjust carburetor.†
Occasional skip (hesitates) at high speed	<ol style="list-style-type: none"> 1. Spark plug gap too close. 2. Carburetor idle mixture adjustment improperly set. 	<ol style="list-style-type: none"> 1. Adjust gap to .030". 2. Adjust carburetor.†
Idles poorly	<ol style="list-style-type: none"> 1. Spark plug fouled, faulty or gap too wide. 2. Carburetor improperly adjusted. 3. Dirty air cleaner. 	<ol style="list-style-type: none"> 1. Reset gap to .030" or replace spark plug. 2. Adjust carburetor.† 3. Clean air cleaner.†
Excessive vibration	<ol style="list-style-type: none"> 1. Cutting blade loose or unbalanced. 2. Bent cutting blade. 	<ol style="list-style-type: none"> 1. Tighten blade and adapter. Balance blade. 2. Replace blade.
Mower will not mulch grass	<ol style="list-style-type: none"> 1. Engine speed too low. 2. Wet grass. 3. Excessively high grass. 4. Dull blade. 	<ol style="list-style-type: none"> 1. Set throttle between 3/4 and full throttle. 2. Do not mow when grass is wet; wait until later to cut. 3. Mow once at a high cutting height, then mow again at desired height or make a narrower cutting swath (1/2 width). 4. Sharpen or replace blade.
Uneven cut	<ol style="list-style-type: none"> 1. Wheels not positioned correctly. 2. Dull blade. 	<ol style="list-style-type: none"> 1. Place all four wheels in same height position. 2. Sharpen or replace blade.

†Refer to separate engine manual packed with your unit.

Note: For repairs beyond the minor adjustments listed above, contact your local authorized service dealer.

Models 093R through 098R



This instruction manual covers various models, and all specifications shown do not necessarily apply to your model. Specifications subject to change without notice or obligation.

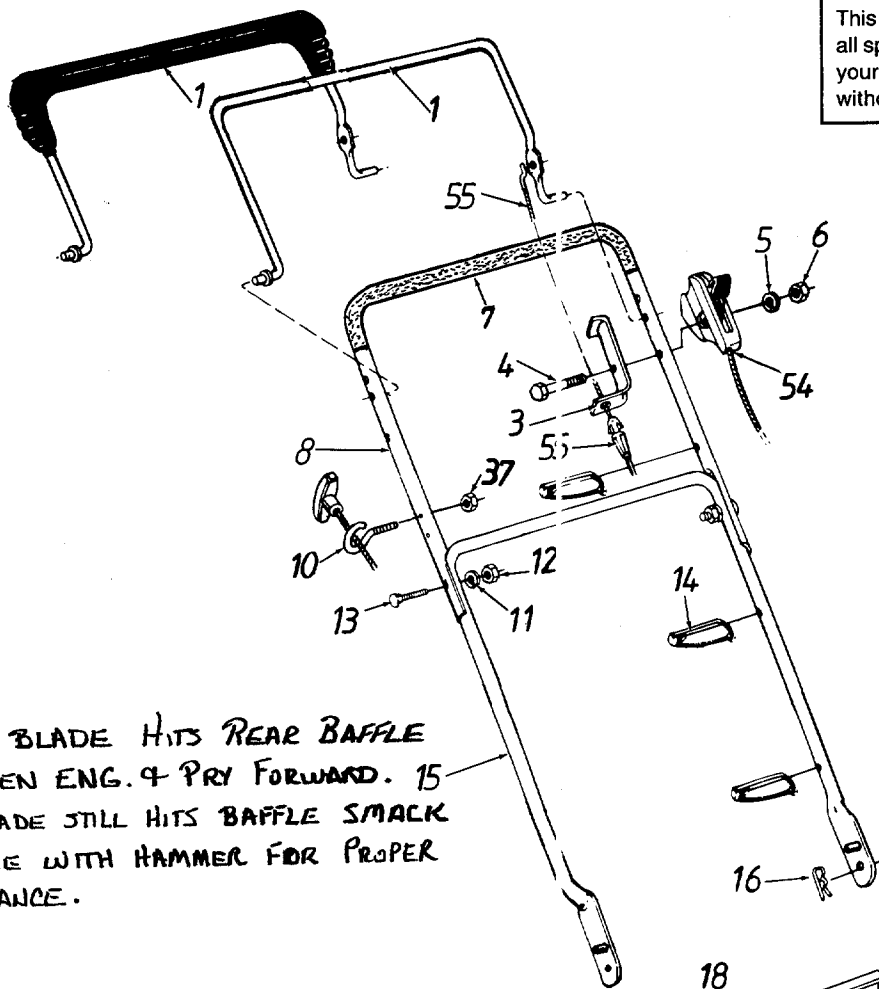

*IF BLADE HITS REAR BAFFLE
 LOOSEN ENG. 4 PRY FORWARD. 15
 IF BLADE STILL HITS BAFFLE SMACK
 BAFFLE WITH HAMMER FOR PROPER
 CLEARANCE.

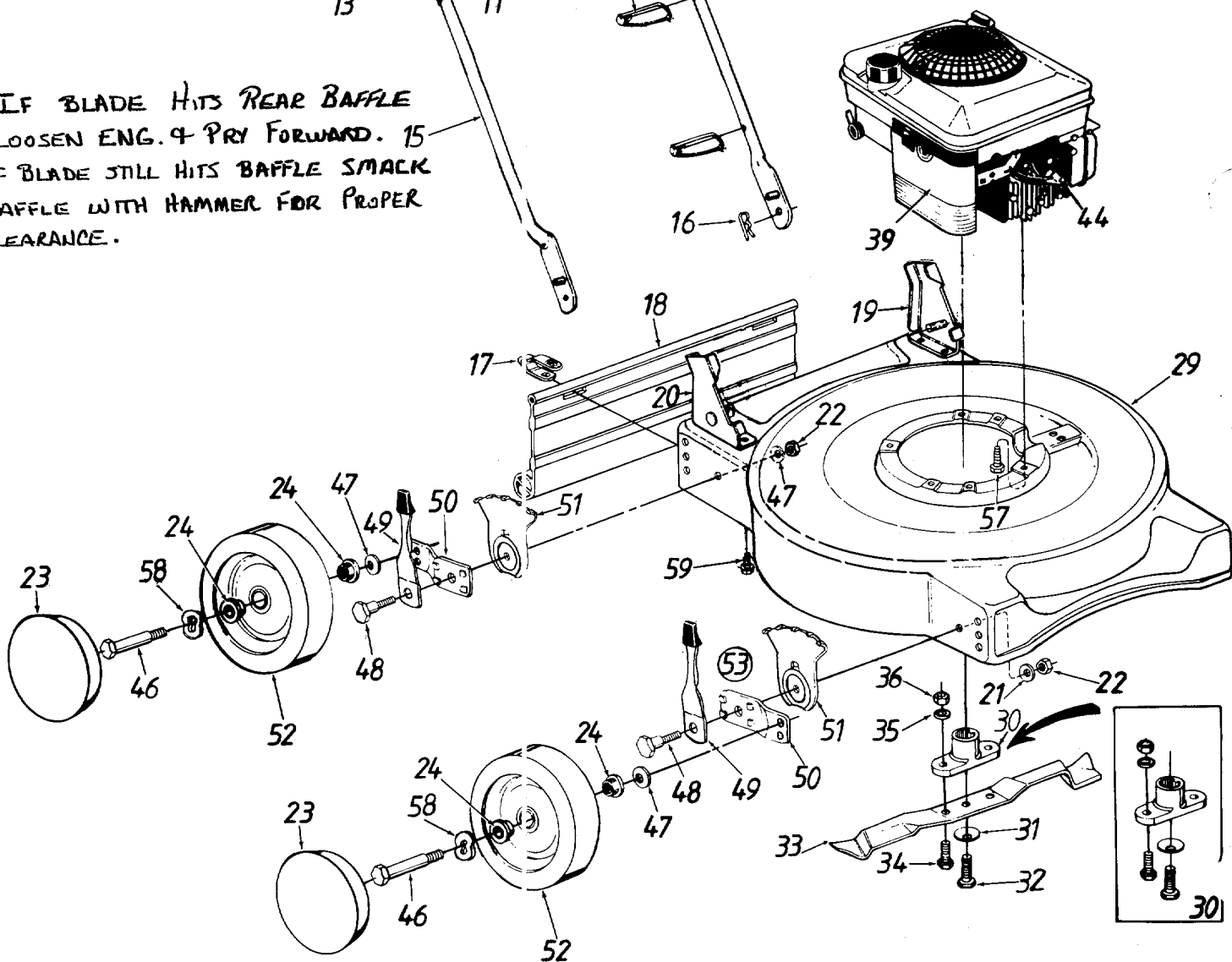

Models 093R thru 098R

PARTS LIST FOR MODEL 098R MULCHING ROTARY MOWER

REF. NO.	PART NO.	CODE	DESCRIPTION	REF. NO.	PART NO.	CODE	DESCRIPTION
1	747-0748		Control Handle Ass'y. (Std.)	33	742-0500		20" Mulching Blade
	731-1135		Control Handle Ass'y. w/Plastic	34	710-1055		Hex Bolt 3/8-24 x 1" Lg.
3	17174		Cable Brkt.	35	736-0169		L-Wash. 3/8" I.D.*
4	710-1216		Hex Bolt 1/4-20 x 1.875" Lg.	36	712-0241		Hex Nut 3/8-24 Thd.
5	736-0175		Spr. Wash. 1/4" I.D.	37	712-0324		Hex L-Nut 1/4-20 Thd.
6	712-0287		Hex Nut 1/4-20 Thd.*	39	—		Engine
7	720-0226		Grip (Optional)	44	735-0639		Spark Plug Boot
8	749-0756A		Upper Handle	46	738-0102		Axle Bolt
10	710-1205	N	Rope Guide Bolt	47	736-0105		Bell-Wash. .400" I.D. x .88"
11	736-0119		L-Wash. 5/16" I.D.*	48	738-0507B		Shld. Bolt .50" Dia. x .357"
12	712-0267		Hex Nut 5/16-18 Thd.*	49	14832		Spring Lever Ass'y. w/Knob
13	710-0671		Curved Carriage Bolt 5/16-18 x 1.38" Lg.	50	15262B		Pivot Bar
14	726-0240		Cable Tie	51	15261A		Height Adj. Plate
15	749-0372B		Lower Handle	52	**		Wheel Ass'y. Comp.
16	714-0104		Hairpin Cotter	53	14578		Height Adj. Ass'y. Comp.— R.F. & L.R.
17	17098		Hinge Clip		14579		Height Adj. Ass'y. Comp.— L.F. & R.R.
18	731-0872		Rear Flap	54	746-0820		Throttle Control Ass'y.††
19	12935A		Handle Bracket Ass'y.—L.H.		746-0834		Throttle Control Ass'y.†
20	12936A		Handle Bracket Ass'y.—R.H.	55	746-0553		Control Cable—36"††
21	736-0356		Bell-Wash. .39" I.D. x 1.38"		746-0737		Control Cable†
22	712-0798		Hex Nut 3/8-16 Thd.*	57	710-0654A		Hex L-Wash. Hd. Scr. 3/8-16 x 1.0" Lg.
23	**		Hub Cap (Optional)				Wave Washer .53" I.D.
24	**		Wheel Bearings	58	736-0232		Hex Wash. Hd. B-Tap Scr. 5/16-18 x .5" Lg.
29	682-0002	638/N	20" Deck Ass'y.	59	710-0603		
30	753-0485		Blade Adapter Kit (Splined)				
31	736-0453		Bell-Wash. .46" I.D.				
32	710-0757		Hex Bolt 7/16-20 x 1.5" Lg.				

†Model 093R & 095R only.

††Models 094R, 096R & 098R only.

*For faster service obtain standard nuts, bolts and washers locally. If these items cannot be obtained locally, order by part number and size as shown on parts list.

CODE: N notes a new part (not previously existing). A three digit number is the color code. Specify color code if color or finish is important when ordering parts. [i.e., 638 for Red Finish].

**Optional Hub Caps REF. 23

Description	Part No.
Gray (for "S" Wave Wheels)	731-0981A
Beige (for "S" Wave Wheels)	731-0982A
Black (1 1/2" Dia.)	720-0251



↖ 720-0249-gray

NOTE: The engine is not under warranty by the mower manufacturer... If repairs or service is needed on the engine, please contact your nearest authorized engine service outlet. Check the "Yellow Pages" of your telephone book under "Engines—Gasoline."

Find It Fast
In The
Yellow Pages

**WHEEL CHART

WHEELS W/O BEARINGS		WHEELS WITH BEARINGS		
TREAD***	ASS'Y. COMP.	TREAD***	ASS'Y. COMP.	BEARINGS
Bar	734-1608	"S" Wave	734-1513B (Gray)	Ball Brg. 1/2" I.D.—741-0180 (2 per wheel)
Diamond	734-1655	"S" Wave	734-1517B (Beige)	Ball Brg. 1/2" I.D.—741-0180 (2 per wheel)
"S" Wave	734-1512A			

***Tread Type: Waffle  ; Rib  ; Bar  ; "T" Tread  ; "S" Wave  ; Diamond 

NOTE: The use of any accessory on this Rotary Mower other than those manufactured by the mower manufacturer is **not** recommended.



WARNING: To reduce the risk of injury, do not operate mower unless rear trailing shield is in its proper place.

)

)

)

REPLACEMENT PARTS • P.O. BOX 360900 • CLEVELAND, OHIO 44136