

# OWNER'S GUIDE

**Model No. 45-213-4**  
**(111-112-036)**

10 CENTS

## ROTARY MOWER

### WARRANTY

For one year from date of purchase, MTD Products Inc, will replace for the original purchaser, free of charge, F.O.B. factory or authorized service firm, any part or parts found to be defective in material or workmanship. All transportation charges on parts submitted for replacement under this warranty must be paid by the purchaser. This warranty does not include replacement of parts which become inoperative through misuse, excessive use, accident, neglect, improper maintenance or alterations by unauthorized persons. This warranty does not include the engine, motor, battery, battery charger or any component parts thereof. For service on these units refer to the applicable manufacturer's warranty.

The above warranty will apply only to the original owner and will be effective only if the warranty card has been properly processed. It will not apply where the unit has been used commercially.

Warranty service is available through your local authorized service dealer or distributor. UNDER NO CIRCUMSTANCES WILL THE RETURN OF A COMPLETE UNIT BE ACCEPTED BY THE FACTORY UNLESS PRIOR WRITTEN PERMISSION HAS BEEN EXTENDED.

### SAFETY RULES

Your rotary mower is a precision piece of power equipment, not a plaything. Therefore exercise extreme caution at all times.

1. Remove all sticks, stones, wire and other hazardous items from lawn before mowing. Such items are dangerous to both the mower and individuals in the vicinity of the mower.
2. Always disconnect spark plug cable during repairs or refueling operations.
3. Always start engine from side opposite discharge chute.
4. NEVER place hands or feet under mower or near discharge chute while engine is running.
5. Do not tilt mower at extreme angle while engine is running. Cut grass on hills and banks sideways, not up and down.
6. Always stop engine when not cutting grass.
7. Do not fill gas tank while engine is running. Do not spill gasoline on hot engine.
8. Keep children and pets away from area at all times during mowing operation. Never allow mower to discharge grass toward any person.
9. Do not attempt to start engine while mower is resting in high grass.
10. Check all nuts and bolts, particularly the blade bolts, for tightness. This is especially important during the initial operation period. Make this same check periodically thereafter.
11. While operating the mower, if any foreign object is struck, stop the mower and inspect for damage. Do not restart or operate the mower until all damage has been repaired.

**WARNING:** Should excessive vibration develop, check your blade and crankshaft immediately. Do not operate mower with an unbalanced blade, a damaged blade or a damaged crankshaft.

# 45-213-4 (111-112-036)

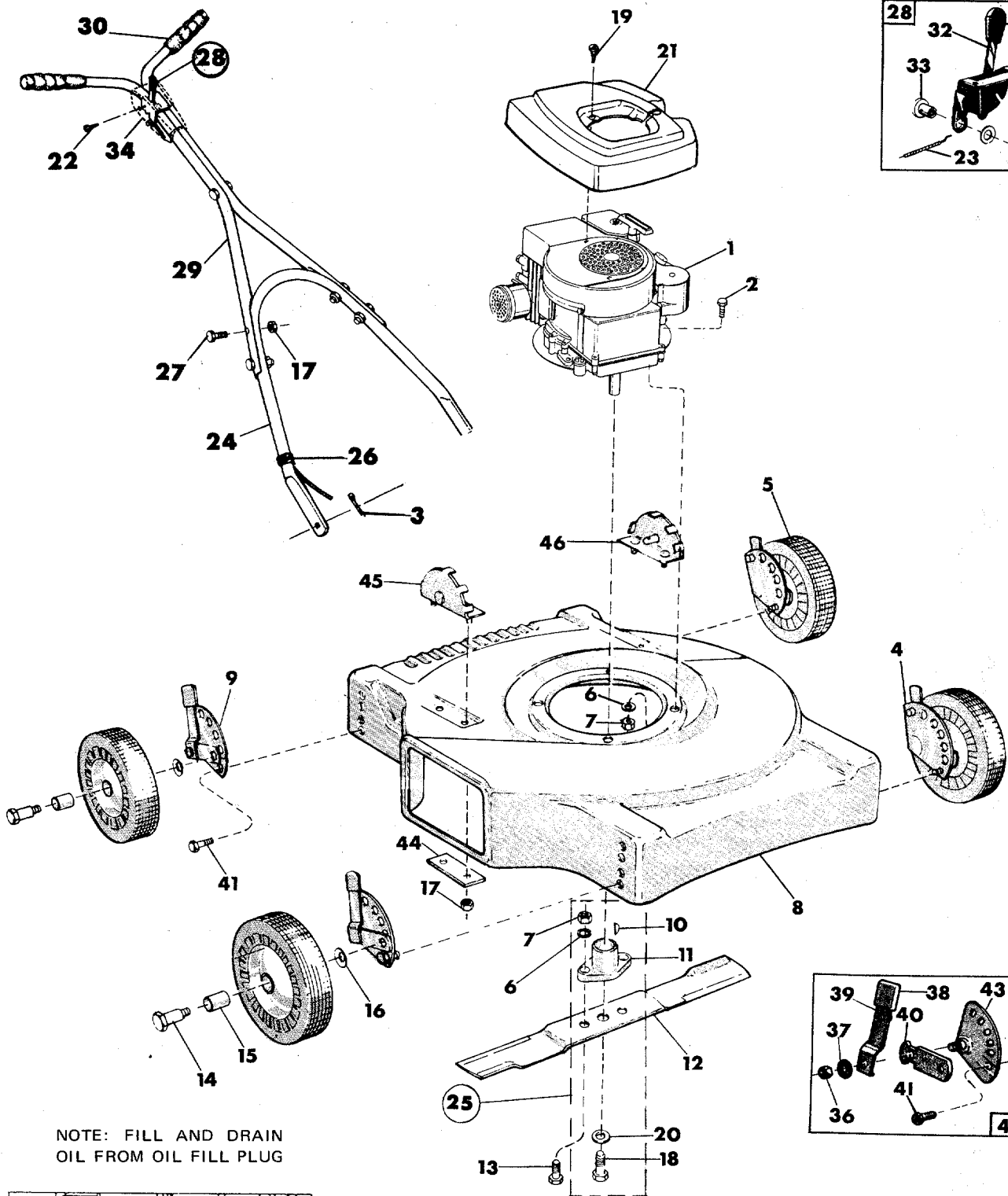

NOTE: FILL AND DRAIN OIL FROM OIL FILL PLUG

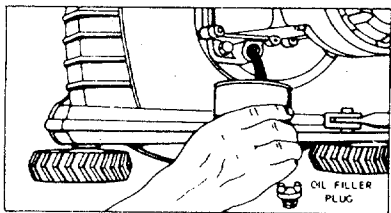

Always disconnect spark plug cable during repairs, refueling or changing oil. Engine oil may be drained through oil filler opening by tilting the mower on its side. Change oil after first 5 hours of operation while engine is warm. Thereafter, change oil every 25 hours of operation while engine is warm.

When ordering parts give the following information:

1. Model number
2. Part number
3. Part name
4. Color of part

**PARTS LIST FOR MOWER MODEL 45-213-4 (111-112-036)**

Ref. No.	Part No.	DESCRIPTION	Ref. No.	Part No.	DESCRIPTION
1	- - - -	Engine	23	732-141	Conduit and Wire ††
2	710-158	Hex Head Machine Screw 5/16-24 x 1-1/2 Lg.*	24	310-9361	Handle - Lower
3	714-104	Hair Pin Cotter	25	901-10769	Blade Adapter Kit/less blade
4	310-10415	Adj. Wheel Ass'y.-L.H. Complete	26	746-145	Cable Clip
5	502-9392	Wheel Assembly	27	710-106	Hex Head Cap Screw 1/4-20x1 1/4 Lg.*
6	736-119	Spring Lockwasher 5/16" Screw††	28	310-10029	Throttle Control (Complete)
7	712-123	Hex Nut 5/16-24 Thread*††	29	310-9354	Handle - Upper
8	413-10754	Deck Assembly	30	720-128	Grip
9	310-10414	Adj. Wheel Ass'y -R.H. Complete	31	305-7470	Knob - Control ††
10	714-365	Key Hi Pro #505 *††	32	310-8367	Control Bracket Assembly ††
11	748-189	Blade Adapter ††	33	901-7627	Ferrule Assembly ††
12	312-7582	Blade - 20"	34	305-9973	Handle Panel
13	710-117	Hex Head Cap Screw 5/16-24 x 1 Lg. (heat treated)††	36	712-116	Elastic Stop Nut **†
14	738-102	Axle Bolt	37	736-105	Belleville Washer **†
15	305-7006	Fortiflex Bearing	38	305-7520	Knob Height Adjuster **†
16	736-105	Belleville Washer *	39	310-8313	Spring Lever **†
17	710-107	Hex Centerlock Nut 1/4-20 Thread*	40	310-7492	Pivot Bar **†
18	710-459	Hex Head Cap Screw 3/8-24 x 1 1/2 Lg. (heat treated)††	41	710-209	Sems Hex Head Cap Screw 3/8-16 x 5/8 Lg.*
19	710-407	Hex. Hd.Ex.Scw. #8-32x 1/2" Lg. *	43	310-10408	Index Plate - R.H. **
20	736-217	Spg. Lckwshr. 3/8"Scw.(hvy. dty.)††		310-10409	Index Plate - L.H. †
21	413-10612	Engine Shroud	44	310-8405	Reinforcement Plate
22	710-129	Self-Tap Scw.#8-32x5/16" Lg.	45	310-8388	Handle Bracket Assembly - R.H.
			46	310-8389	Handle Bracket Assembly - L.H.

\* For faster service obtain standard nuts, bolts and washers locally. If these items cannot be obtained locally, order by part number and size as shown on the parts list.

+ + Part of Throttle Control Complete (Optional Handle 310-10029).

†† Part of Blade Adapter Kit / less Blade (901-10769).

\*\* Part of Wheel Adjustment Assembly R.H. Complete (310-10414).

† Part of Wheel Adjustment Assembly L.H. Complete (310-10415).

If repairs or service is needed on the engine, please contact your nearest authorized engine service outlet. Check the "Yellow Pages" of your telephone book under "Engines - Gasoline"



When ordering replacement parts, be sure to specify your mower model number, part number, description of part, and the number of parts required . . . Parts and service should be handled by your nearest authorized service firm as recommended by your dealer. Request for parts and service received at the factory will be forwarded to the appropriate Central Service Distributor in your area for handling.

## ASSEMBLY INSTRUCTIONS

### ASSEMBLY — Optional handle

Your new mower is shipped completely assembled with the exception of the handle and throttle control assembly.

1. Remove lawn mower and all parts from carton. Make certain that all loose parts and literature are removed from carton before carton is discarded.
2. Extend throttle control assembly, which is attached to engine, to rear of mower and place on floor.  
*CAUTION: Do not bend or kink control wire.*
3. Assemble upper handle to lower handle using four each screws and lock nuts provided in parts bag.
4. Assemble complete handle assembly to mower so that throttle control mounting hole in upper handle will be on right side. Holes at bottom of lower handle are to be fitted over studs located in front of each rear wheel mounting position.
5. Position throttle control assembly on right hand side of upper handle so that holes in control assembly and handle are in line. Secure in place with screw and lock nut found in parts bag. Secure throttle wire to lower right handle tube with clips in parts bag.
6. Place the plastic control cover over the throttle control and secure with two self-tapping screws.

### OPERATION

**NOTE:** For shipping purposes your mower is set with the wheels in a low cutting height position. For best results, raise the cutting position until it is determined which height is best for your lawn. See adjustments.

1. Service engine with gas and oil. See Engine Manual packed with lawn mower for complete instructions for the care and maintenance of engine. **READ DIRECTIONS CAREFULLY.**
2. When ready to start engine, place throttle control lever in "START" position and start engine in accordance with instructions in Engine Manual. After engine starts, move throttle control lever to desired engine speed. The engine is stopped by placing control lever in the "STOP" position.
3. Be sure that lawn is clear of stones, sticks, wire or other objects which could damage lawn mower or engine. For best results and to insure more even grass distribution, do not mow when lawn is excessively wet.
4. Check blade bolts for proper tightness.

### ADJUSTMENTS

**CAUTION:** Do not at any time make any adjustment to lawn mower without first stopping engine and disconnecting spark plug wire.

**CUTTING HEIGHT** — An adjusting plate and thumb lever at each wheel position provides cutting height adjustment. Each adjusting plate has five holes. Height of cut will be changed when the thumb lever is moved from one hole to another. Simply depress thumb lever towards wheel and move wheel and lever assembly to desired position. Cutting height will be raised as lever is moved toward front and lowered as lever is moved toward rear. All wheels must be positions in relative height of cut positions.

**THROTTLE** — If adjustment becomes necessary, the throttle control wire assembly can be reset as follows:

1. Loosen, but do not remove screw securing throttle control wire assembly at engine.
2. Move throttle control lever on handle to "FAST" position.
3. Move lever, to which control wire is fastened at engine,

to full open position and retighten screw to secure throttle control wire assembly.

### LUBRICATION

**IMPORTANT:** Always stop engine and disconnect spark plug wire before cleaning, lubricating or doing any kind of work on lawn mower.

**WHEELS:** Wheel bearings are of lifetime Fortiflex. They require no lubrication.

**THROTTLE:** Periodically lubricate throttle control lever and throttle wire assembly with a few drops of light oil (S.A.E. No. 10 or 20) for ease of operation.

**ENGINE:** Follow Engine Manual for lubrication instructions.

### MAINTENANCE

**CUTTING BLADE** — The blade may easily be removed for grinding or replacement as follows:

1. Remove bolt and lock washer holding blade and hub assembly to engine crankshaft.
2. Remove blade and hub assembly from engine crankshaft.
3. Remove two bolts, lock washers and nuts holding blade to blade hub.

When sharpening blade, follow the original angle of grind as a guide. It is extremely important that each cutting edge receives an equal amount of grinding to prevent an unbalanced blade. An unbalanced blade will cause excessive vibration when rotating at high speeds and may cause damage to the mower.

Upon reassembly, make certain all parts are assembled properly and tightened securely.

**DECK** — The underside of mower deck should be cleaned after each period of use as grass clippings, leaves, dirt and other matter will accumulate. This accumulation of grass clippings, etc. is undesirable as it will invite corrosion and may cause an uneven discharge of grass clippings at the next cutting.

The deck may be cleaned by tilting the mower forward or on its left side and scraping clean with a suitable tool or by washing with a stream of water from a garden hose.

**CAUTION:** Do not direct the stream of water at a hot engine as damage to the engine may result.

**STORAGE** — The following steps should be taken to prepare lawn mower for storage.

1. Clean and lubricate mower thoroughly as described in the preceding instructions.
2. Refer to Engine Manual for correct engine storage instructions.
3. Coat mower's cutting blade with chassis grease to prevent rusting.
4. Place blocks under deck to raise tires clear of floor.
5. Store mower in a dry, clean area.

### USING YOUR MOWER

For best results, do not cut wet grass because it tends to stick to underside of the mower thus preventing proper discharge of grass clippings. If wet grass must be cut, reduce engine speed and walking speed to help distribute the clippings more effectively.

New grass should be treated as wet grass, otherwise a normal walking speed is about the right pace for efficient mowing . . . The best mowing pattern is one that allows the clippings to discharge towards the uncut part of the lawn. This permits recutting of the clippings to further pulverize them. When cutting high weeds, discharge towards cut portion, then recut at right angles to first direction.

Lawn should be cut in the fall as long as there is growth.