

PRO-8 Tabletop Proofer

Project _____

Item _____

Quantity _____



SIZE:

PRO-8 - 39-3/4" High, 24-1/4" Wide, 34-5/8" Deep
1010 mm High, 616 mm Wide, 880 mm Deep

NU-VU's PRO-8 Tabletop proofer has a stainless steel exterior and tempered glass doors for full view of your product. A manual fill water pan located at the bottom of the unit provides the humidity, while the fan provides uniform distribution of heat and humidity.

The PRO-8 has a capacity of 8 full size pans and 16 half-size pans.

CONSTRUCTION:

- Welded stainless steel exterior
- Aluminum interior
- Fully insulated
- Control panel accessible through front of unit
- Heating elements accessible inside of cabinet and through bottom

CONTROLS:

- Mechanical controls
- Indicator light for thermostat
- Separate heat and humidity controls

STANDARD FEATURES:

- Stainless steel exterior
- Aluminum interior
- Set of 4" adjustable legs
- Full view tempered glass door
- Silicone rubber door gasket
- Manual fill water pan

OPTIONAL FEATURES:

- Warmer
- Set of four casters

NU-VU® PRO-8 Tabletop Proofer

LABORATORY CERTIFICATION AND APPROVAL



NU-VU® Food Service Systems

www.nu-vu.com
5600 13th Street
Menominee, MI 49858

1-800-338-9886 Toll Free
1-906-863-4401 Phone
1-906-863-5889 Fax

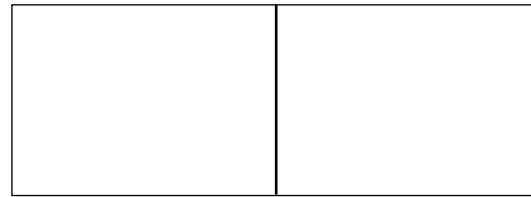

Approval / Stamp

PRO-8 Tabletop Proofer

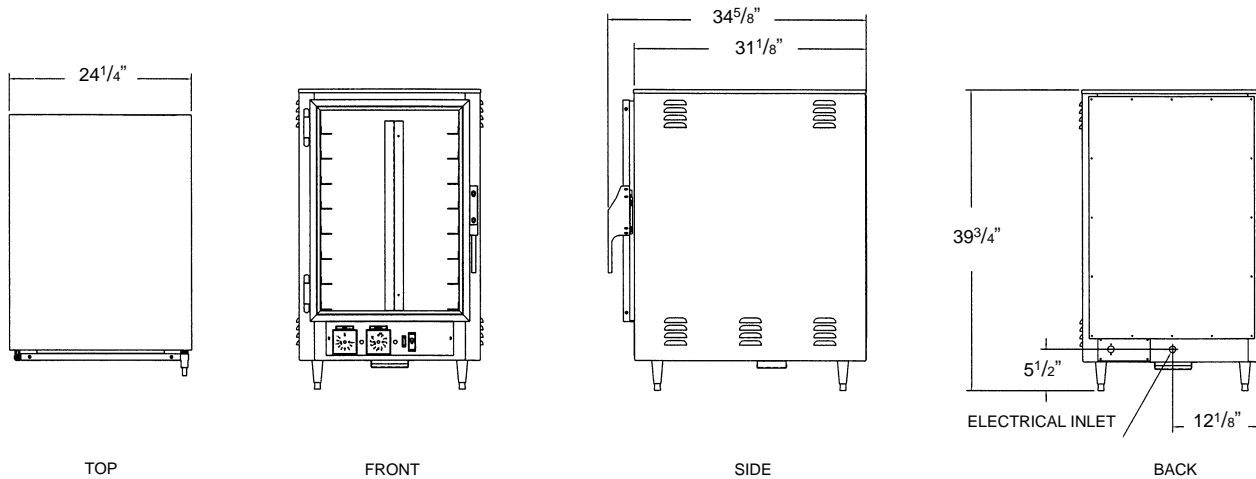

NU-VU® PRO-8 Tabletop Proofer

SPECIFICATIONS:

ELECTRICAL:

- 120-Volt single phase is standard.

SERVICE CONNECTIONS:

- Unit is shipped from factory with a cord and plug.
- The proofer contains two 600 Watt elements and one 625 Watt element controls the the manual fill humidity system.

ELECTRICAL:

Amp Draw	120/1
L1	16

LISTINGS:

The PRO-8 has NSF & C-ETL-US listings.



INSTALLATION:

Allow four inches on each side and back of unit for ventilation of oven.

CAPACITY:

	18"x26" Sheet Pans	13"x18" Sheet Pans	Spacing
Proofer	8	16	3-5/16"

DIMENSIONS:

	Height	Width	Depth
Exterior	39-3/4"	24-1/4"	34-5/8"
Interior	27-7/8"	18-3/8"	29"

DOOR SWING: Proofer - 23-7/8" (606 mm)

PACKING SIZE:

45" High, 36" Wide, 36" Deep
(1143 mm High, 914 mm Wide, 914 mm Deep)

SHIPPING WEIGHT:

200 Pounds (91 Kg), FOB Menominee, MI 49858