

SCAG[®]

POWER EQUIPMENT

MODEL SCR

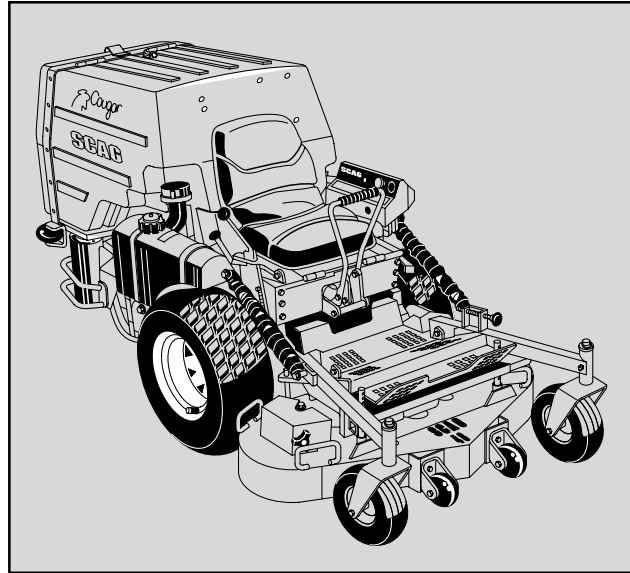

THIS MANUAL CONTAINS THE OPERATING INSTRUCTIONS AND SAFETY INFORMATION FOR YOUR SCAG MOWER. READING THIS MANUAL CAN PROVIDE YOU WITH ASSISTANCE IN MAINTENANCE AND ADJUSTMENT PROCEDURES TO KEEP YOUR MOWER PERFORMING TO MAXIMUM EFFICIENCY. THE SPECIFIC MODELS THAT THIS BOOK COVERS ARE CONTAINED ON THE INSIDE COVER. BEFORE OPERATING YOUR MACHINE, PLEASE READ ALL THE INFORMATION ENCLOSED.

OPERATOR'S MANUAL



WARNING:

FAILURE TO FOLLOW SAFE OPERATING PRACTICES MAY RESULT IN SERIOUS INJURY.

- * Keep all shields in place, especially the grass discharge chute.
- * Before performing any maintenance or service, stop the machine and remove the spark plug wire and ignition key.
- * If a mechanism becomes clogged, stop the engine before cleaning.
- * Keep hands, feet and clothing away from power-driven parts.
- * Read this manual completely as well as other manuals that came with your mower.
- * Keep others off the tractor (only one person at a time)

REMEMBER - YOUR MOWER IS ONLY AS SAFE AS THE OPERATOR!

Hazard control and accident prevention are dependent upon the awareness, concern, prudence, and proper training of the personnel involved in the operation, transport, maintenance, and storage of the equipment.

This manual covers the operating instructions
and illustrated parts list for:

SCR42-25CH	with a serial number of 7530001 to 7539999
SCR48-27KA	with a serial number of 7550001 to 7559999
SCR48-25CH	with a serial number of 7540001 to 7549999
SCR52-25CH	with a serial number of 7560001 to 7569999
SCR52-27KA	with a serial number of 7570001 to 7579999

Always use the entire serial number listed on the serial number tag when referring to this product.

GENERAL INFORMATION

1.1 INTRODUCTION

Your mower was built to the highest standards in the industry. However, the prolonged life and maximum efficiency of your mower depends on you following the operating, maintenance and adjustment instructions in this manual.

If additional information or service is needed, contact your Scag Power Equipment Dealer.

We encourage you to contact your dealer for repairs. All Scag dealers are informed of the latest methods to service this equipment and provide prompt and efficient service in the field or at their service shop. They carry a full line of Scag service parts.

USE OF OTHER THAN ORIGINAL SCAG REPLACEMENT PARTS WILL VOID THE WARRANTY.

When ordering parts, always give the model and serial number of your tractor. The serial number plate is located where shown in Figure 1-1.

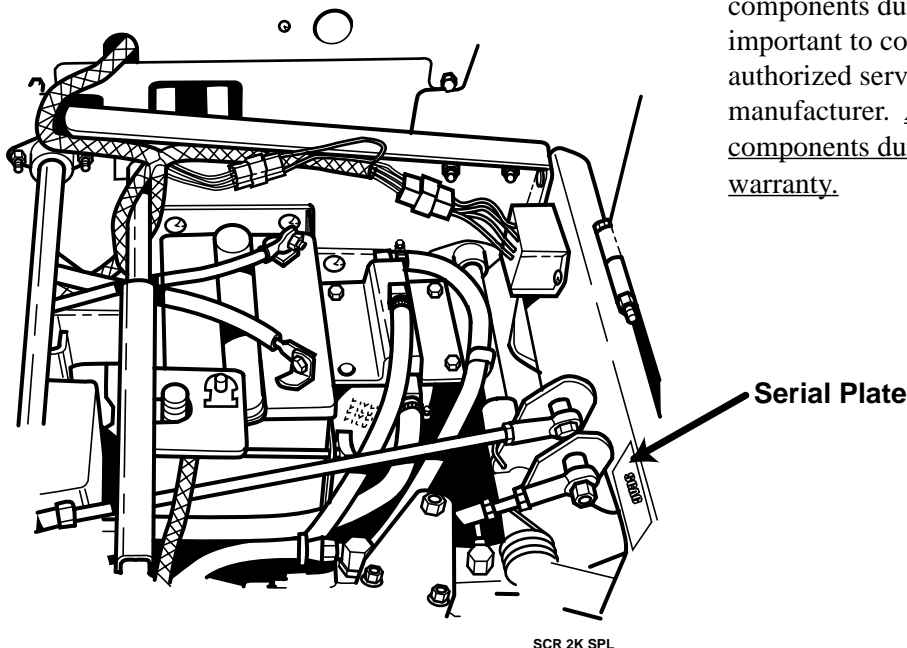

SCR 2K SPL

Figure 1-1 Tractor Serial Number Plate Location

For pictorial clarity, some illustrations and figures in this manual may show shields, guards or plates open or removed. Under no circumstances should your mower be operated without these devices in place.

All information is based upon product information available at the time of approval for printing. Scag Power Equipment reserves the right to make changes at any time without notice and without incurring any obligation.









1.2 DIRECTION REFERENCE











The “Right” and “Left”, “Front” and “Rear” of the machine are referenced from the operator’s right and left when seated in the normal operating position and facing the forward travel direction.

1.3 SERVICING THE ENGINE AND DRIVE TRAIN COMPONENTS

The detail servicing and repair of the engine, hydraulic pumps and gearboxes are not covered in this manual; only routine maintenance and general service instructions are provided. For service of these components during the limited warranty period, it is important to contact your Scag dealer or find a local authorized servicing agent of the component manufacturer. Any unauthorized work done on these components during the warranty period may void your warranty.

ISO Symbols		CE Mark
--------------------	--	----------------

SYMBOL	DESCRIPTION	SYMBOL	DESCRIPTION
	Choke		Transmission
	Parking Brake	 <small>48071S</small>	Spinning Blade
	On/Start		Spring Tension on Idler
	Off/Stop		Oil
		Falling Hazard	

SYMBOL	DESCRIPTION	SYMBOL	DESCRIPTION
	Fast		Slow
	Continuously variable - Linear		Cutting element - Basic symbol
	Pinch Point		Cutting element - Engage
	Hourmeter/elapsed operating hours		Cutting element - Disengage
	Keep bystanders away		Read operator's manual

SAFETY INFORMATION

2.1 INTRODUCTION

Your mower is only as safe as the operator. Carelessness or operator error may result in serious bodily injury or death. Hazard control and accident prevention are dependent upon the awareness, concern, prudence, and proper training of the personnel involved in the operation, transport, maintenance and storage of the equipment. Make sure every operator is properly trained and thoroughly familiar with all of the controls before operating the mower.

READ THIS OPERATOR'S MANUAL BEFORE ATTEMPTING TO START YOUR MOWER.

A replacement manual is available from your authorized Scag Service Dealer or by Contacting Scag Power Equipment, Service Department at P.O. Box 152, Mayville, WI 53050. Please indicate the complete model and serial number of your Scag product.

2.2 SIGNAL WORDS



This symbol means "**Attention! Become Alert! Your Safety is Involved!**" The symbol is used with the following signal words to attract your attention to safety messages found on the decals and throughout this manual. The message that follows the symbol contains important information about safety. To avoid injury and possible death, carefully read the message! Be sure to fully understand the causes of possible injury or death.

Signal Word:

It is a distinctive word on safety decals and throughout this manual that alerts the viewer to the existence and relative degree of the hazard.

DANGER:

The signal word "DANGER" denotes that an extremely hazardous situation exists on or near the machine that could result in high probability of death or irreparable injury if proper precautions are not taken.

WARNING:

The signal word "WARNING" denotes a hazard exists on or near the machine that can result in injury or death if proper precautions are not taken.

CAUTION:

The signal word "CAUTION" is a reminder of safety practices on or near the machine that could result in personal injury if proper precautions are not taken.

Your safety and the safety of others depends significantly upon your knowledge and understanding of all correct operating practices and procedures of this machine.

2.3 BEFORE OPERATION CONSIDERATIONS

1. **NEVER** allow children to operate this riding mower. Do not allow adults to operate this machine without proper instructions.
2. **DO NOT** mow when children and/or others are present.
3. Clear the area to be mowed of objects that could be picked up and thrown by the cutter blades.
4. **DO NOT** carry passengers.

Section 2

5. **DO NOT** wear loose fitting clothing that could get tangled in moving parts. Do not operate the machine wearing shorts; always wear adequate protective clothing including long pants. Wearing safety glasses, safety shoes and a helmet is advisable and is required by some local ordinances and insurance regulations.
6. Operator hearing protection is recommended, particularly for continuous operation of the mower. Wear suitable hearing protection. Prolonged exposure to loud noise can cause hearing impairment or loss.
7. Keep the machine and attachments in good operating condition. Keep all shields and safety devices in place. If a shield, safety device or decal is defective or damaged, repair or replace it before operating the machine.

WARNING:

This machine is equipped with an interlock system intended to protect the operator and others from injury. This is accomplished by preventing the engine from starting unless the operator is seated in the seat, the deck drive is disengaged, and the speed control is placed in the neutral position with the parking brake applied. The system also shuts off the engine if the operator leaves the seat with the mower running and the speed control is not in the neutral position with the parking brake applied. It will also shut off the engine if the hopper is raised with the cutter deck drive engaged. Never operate equipment with the interlock system disconnected or malfunctioning.

8. Be sure interlock switches are functioning correctly.
9. Fuel is flammable; handle with care. Fill fuel tank outdoors. Never fill indoors. Use a funnel or spout to inhibit spillage. Clean up any spillage before starting the engine.
10. **DO NOT** add fuel to a running or hot engine. An explosion could occur. Allow engine to cool for several minutes before adding fuel.
11. Keep flammable objects (cigarettes, matches, etc.), open flames and sparks away from the fuel tank and fuel container.

12. Equipment must comply with the latest requirements per ANSI J137 and/or ANSI S279 when driven on public roads.

-NOTE-

If the mower is driven on public roads, it must comply with state and local ordinances as well as SAE J137 and/or ANSI / ASAE S279 requirements. Contact your local authorities for regulations and equipment requirements.

13. **DO NOT** operate without a chute deflector installed; keep the deflector in lowest possible position.
14. Check the blade mounting bolts at frequent intervals for proper tightness.
15. Make sure all hydraulic fluid connections are tight and all hydraulic hoses and lines are in good condition before starting the machine.

2.4 OPERATION CONSIDERATIONS

1. Know the function of all controls and how to stop quickly.
2. Reduce speed and exercise extreme caution on slopes and in sharp turns to prevent tipping or loss of control. Be especially cautious when changing directions on slopes.

WARNING:

DO NOT operate on steep slopes. To check a slope, attempt to drive up it (with cutter deck down). If machine can drive up the slope without the wheels slipping, reduce speed and use extreme caution. ALWAYS FOLLOW OSHA APPROVED OPERATION.

3. Do not stop or start suddenly. **WHEN MOWING A HILLSIDE, MOW UP AND DOWN THE FACE OF SLOPES, NEVER ACROSS THE FACE.**
4. When using any attachment, never direct the discharge of material toward bystanders or allow anyone near the machine while in operation.

5. Before attempting to start the engine, with the operator in the seat, disengage power to the cutter deck, place the hopper in the stowed position, steering control levers in the neutral position and engage the parking brake.
6. If the mower discharge ever plugs, shut off the engine, remove the ignition key, and wait for all movement to stop before removing the obstruction. Do not use your hand to dislodge the clogged discharge chute. Use a stick or other device to remove clogged material.
7. Be alert for holes, rocks, and roots in the terrain and other hidden hazards. Keep away from any dropoff. Beware of overhead obstructions such as low limbs, etc. and underground obstacles such as sprinklers, pipes, tree roots, etc. Cautiously enter a new area. Be alert for hidden hazards.
8. Disengage power to cutter deck before backing up. Do not mow in reverse unless absolutely necessary and then only after observation of the entire area behind the mower.
9. **DO NOT** turn sharply. Use care when backing up.
10. Disengage power to cutter deck before crossing roads, walks or gravel drives. Watch for traffic when crossing roads or operating near roadways.
11. Mow only in daylight or good artificial light.
12. Take all possible precautions when leaving the machine unattended, such as disengaging the mower, lowering the attachments, setting the parking brake, stopping the engine, and removing the key.
13. Disengage power to the attachments when transporting or when not in use.
14. The machine and attachments should be stopped and inspected for damage after striking a foreign object, and damage should be repaired before restarting and operating the machine.

15. **DO NOT** touch the engine or the muffler while the engine is running or immediately after stopping. These areas may be hot enough to cause a burn.
16. **DO NOT** run engine inside a building or confined area without proper ventilation. Exhaust fumes are hazardous and could cause death.

2.5 MAINTENANCE CONSIDERATIONS

1. Never make adjustments to the machine with the engine running unless specifically instructed to do so. If the engine is running, keep hands, feet, and clothing away from moving parts.
2. Remove the key from the ignition switch to prevent accidental starting of the engine when servicing or adjusting the machine.
3. Keep all nuts, bolts and screws tight to ensure the machine is in safe working condition. Check blade mounting bolts frequently to be sure they are tight.
4. Do not change the engine governor settings or overspeed the engine. See the engine operator's manual for information on engine settings.
5. To reduce fire hazard, keep the engine free of grass, leaves, excessive grease and dirt.
6. **Hydraulic fluid is under high pressure.** Keep body and hands away from pinholes or nozzles that eject hydraulic fluid under high pressure. Use only cardboard or paper to search for leaks. If you need service on your hydraulic system, please see your authorized Scag dealer.
7. Hydraulic fluid under high pressure may have sufficient force to penetrate skin and cause serious injury. If hydraulic fluid is injected into the skin, it must be surgically removed within a few hours by a doctor or gangrene may result.

Section 2

2.6 SAFETY AND INSTRUCTIONAL DECALS

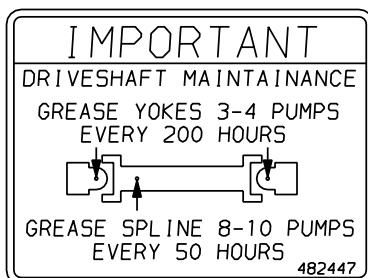
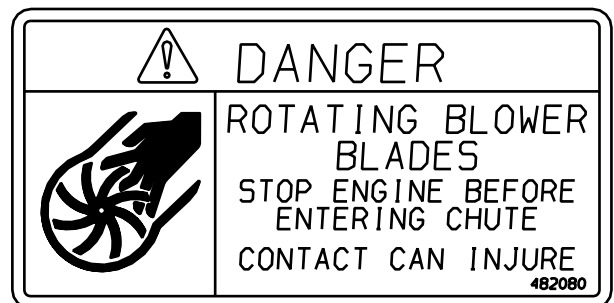
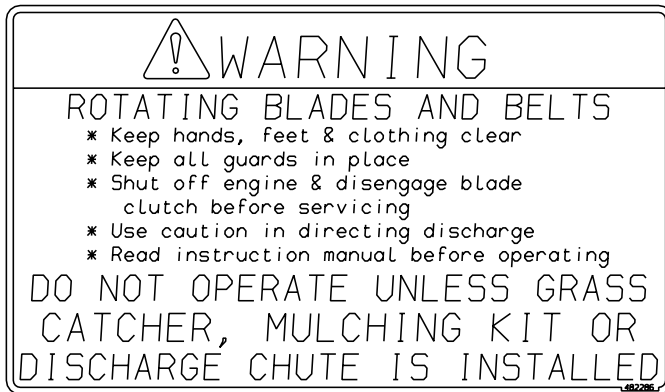
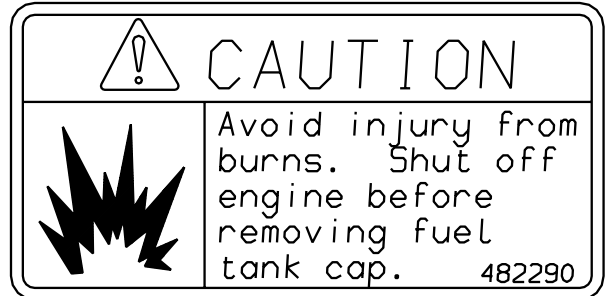

SPECIFICATIONS

3.1 ENGINE

General Type	Heavy Duty Industrial/Commercial Gasoline
Brands	Kohler & Kawasaki
Model	25 HP Kohler Command CH25S & 27HP Kawasaki FD750D
Horsepower	25 HP at 3600 RPM (SCR42-25CH, SCR48-25CH & SCR52-25CH)
.....	27HP at 3600 RPM (SCR48-27KA & SCR52-27KA)
Type	4 Cycle Gasoline, Twin Cylinder, Horizontal Shaft
Displacement	Kohler - 725 cc. & Kawasaki - 745cc
Cylinders	2 with Cast Iron Sleeves
Governor	Mechanical Type with Variable Speed Control Set At 3600 RPM
Idle Speed	1400 RPM
Fuel Pump Group	Mechanical Fuel Pump with In-Line Fuel Filter, Fixed Jet Carburetor with Smart-Choke™ and Fuel Shutdown Solenoid
Fuel	Non-Leaded Gasoline with a Minimum Octane Rating of 87
Oil Pump Group:	Positive Displacement Gerotor™ Oil Pump with Remote Oil Filter
Starter	Electric Starting with Cell Starter
Belts:	
Engine Belt	Scag Part Number - 481976
Blower Drive Belt	Scag Part Number - 481977
Pump Drive Belt	Scag Part Number - 481978

3.2 ELECTRICAL

Battery	12 Volt
Charging System	Alternator
Charging Output	12 Volt, 15 Amp
System Polarity	Negative Ground
Starter	12 Volt Electric Solenoid Shift Type
Interlock Switches	Seat, Neutral Control, Mower Engagement (BBC), Hopper and Parking Brake
Instrument Panel	Ammeter, Hourmeter, Key Switch, Throttle Lever, Manual Choke, BBC Lever, Fuses, and Water Temp Gauge (KA Only)
Fuses	Two (2) 20 Amp

3.3 TRACTOR

Drive System	Hydraulic Drive with Two Variable Displacement Pumps and Two Cast-iron High Torque Motors
Hydrostatic Pumps	Two Hydro-Gear™ BDP 10L Pumps with Dump Valves for movement without running the engine
Drive Wheel Motors	Two Ross Model MB 15cu. inch Cast-iron High Torque Motors
Steering/Travel Control	Twin Lever Fingertip Steering Control with Individual Control to Each Wheel
Parking Brake	Lever Actuated Linkage to Brakes on Both Drive Wheel Axles
Wheels:	
(2) Front Caster	11 x 4.0-5 Smooth Tires
(2) Drive	23 x 9.5-12 Four-Ply Pneumatic Tubeless, Radius Edge
(1) Rear	
Fuel Tank	Two, 3.75 gallon Polyethylene Tanks with Large Fuel Tank filler neck and Fuel Gauge Fill Caps
Tire Pressure:	
Front Caster	25 PSI
Drive	12 PSI
Rear	25 PSI
Seat	Padded

Section 3

3.3 TRACTOR (CONT'D)

-NOTE-

Travel Speed:	
Forward	0 - 8.5 MPH
Reverse	0 - 5.0 MPH

The machine will travel at 8.5 mph for transport purposes. For best cutting performance the forward travel speed should be adjusted depending upon the cutting conditions.

3.4 CUTTER DECK

No. of Blades	3
Width of Cut	42", 48" & 52"
Cutter Blades	Three (3) 16-1/2" (P/N 481997) Marbane Blades
Deck Drive	Belt Driven Manual Clutch Connected to a Drive Shaft to a Gearbox on the Cutter Deck
Manual Clutch Type	Manual blade engagement system with engagement lever and double v-belt drive
Cutting Height Adjustment	Four Corner Pin Adjustment, 1.5" to 5" in 1/2" increments
Deck Tilt	Manually by Lifting Deck and Engaging Lock Pin
Drive Shaft	Shaft With Two High Speed U-Joints

3.5 GRASS CATCHING SYSTEM

Type	Out-Front Rear Deck Discharge into Blower which discharges the Grass Clippings into a Hopper
Hopper	90-Gallon Molded Plastic with Oscillating Discharge Chute
Discharge Blower	12" Diameter
Side Discharge	Extra Wide Discharge Opening on the Left Hand Side with Spring Loaded Discharge Chute

3.6 HYDRAULIC SYSTEM

Hydraulic Oil Filter	10 Micron Spin-on Element Type
Hydraulic Reservoir	Nylon; 6 Quart Capacity

3.7 WEIGHTS AND DIMENSIONS

	SCR42-25CH	SCR48-25CH	SCR48-27KA
Length	95.0"	95.0"	95.0"
Overall Width	42.0"	48.0"	48.0"
Overall Height	44.0"	44.0"	44.0"
Operating Weight	1285 lbs.	1260lbs.	1300lbs.
	SCR52-25CH	SCR52-27KA	
Length	95.0"	95.0"	
Overall Width	52.0"	52.0"	
Overall Height	44.0"	44.0"	
Operating Weight	1300lbs.	1350lbs.	

3.8 PRODUCTIVITY

The following chart will aid you in determining how many acres your Scag mower will cut per day.

The chart is an estimate based on 8 hours per day cutting time at 4 MPH with an allowance for overlap and turns.

Cutting Width:	42"	48"	52"
Acres Per Day:	20	21	23

OPERATING INSTRUCTIONS



CAUTION:

Do not attempt to operate this mower unless you have read this manual. Learn the location and purpose of all controls and instruments before you operate this mower.

4.1 CONTROLS AND INSTRUMENT IDENTIFICATION

Before operating the mower, familiarize yourself with all mower and engine controls. Knowing the location, function and operation of these controls is important for safe and efficient operation of the mower.

1. **Ignition Switch (Figure 4-1).** Used to start the engine and has three positions; OFF, ON, and START.
2. **Mower Deck Control (Figure 4-1).** Used to engage and disengage the mower drive system. Pushing the lever forward will engage the deck drive. Pulling the lever back will disengage the deck drive.
3. **Engine Choke Control (Figure 4-1).** Used to start a cold engine.
4. **Engine Throttle Control (Figure 4-1).** Used to control the engine speed. Pushing the lever forward increases engine speed. Pulling the lever back decreases engine speed. Full back position is the IDLE position. Full forward is the cutting position.
5. **Ammeter (Figure 4-1).** Indicates the condition of the charging system. When the engine is running the needle should be at the positive end of the meter. If the needle is on the negative end of the meter, this indicates a discharge condition and the machine should be taken in for service.

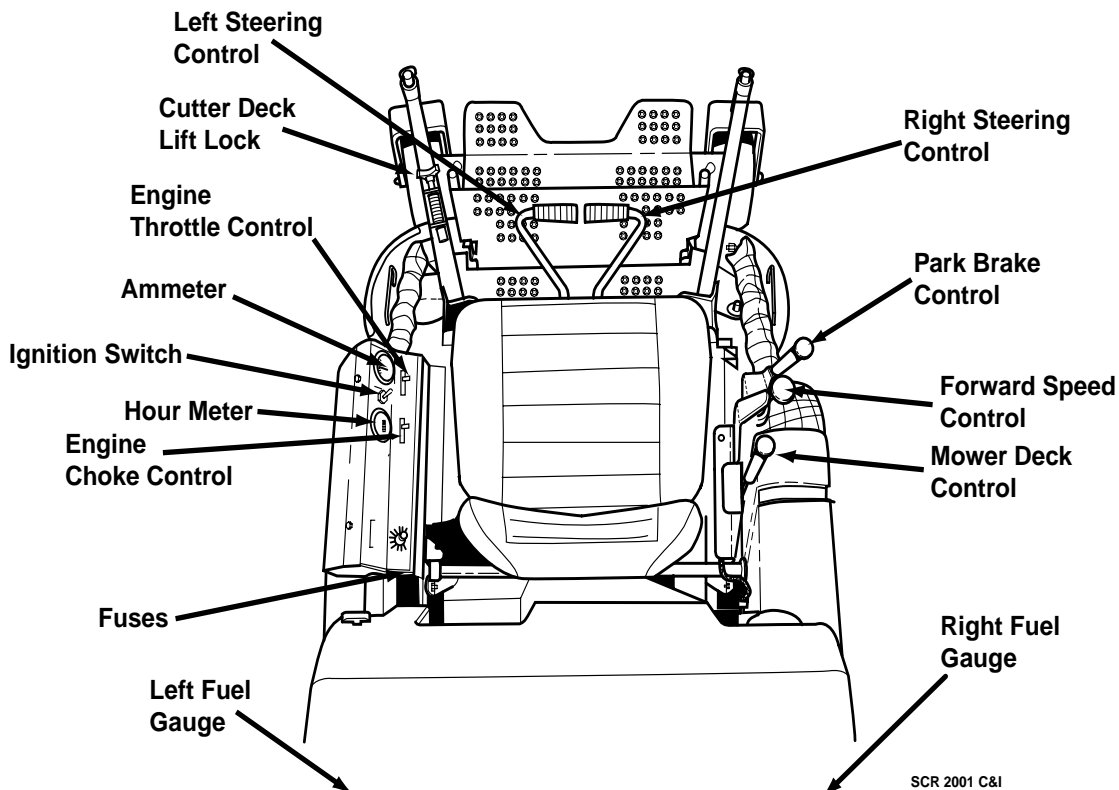

SCR 2001 C&I

Figure 4-1 Controls and Instruments

Section 4

6. **Hour Meter (Figure 4-1).** Indicates the number of hours the engine has been operated. It operates whenever the ignition switch key is in the ON position. It can be used to keep track of maintenance intervals and the amount of time required to perform various tasks.
7. **Fuse Holders (Figure 4-1).** Two 20-amp fuses protect the mower's electrical system. To replace fuses, pull fuse out of the socket and install a new fuse.
8. **Left Steering Control (Figure 4-1).** Used to control the mower's left wheel when traveling forward or reverse.
9. **Right Steering Control (Figure 4-1).** Used to control the mower's right wheel when traveling forward or reverse.
10. **Parking Brake Control (Figure 4-1).** Used to engage and disengage the parking brakes and also used to lock the cutter deck from tilting up too high while traveling. Pull the lever back and lock in place to engage the parking brakes. Push the lever forward to disengage the parking brakes and engage the deck tilt lock.
11. **Forward Speed Control (Figure 4-1).** Used to control the mower's forward speed. Push the lever forward to increase the forward speed.
12. **Fuel Tank Gauges (Figure 4-1).** Indicates the amount of fuel in the fuel tanks.
13. **Dump Valve Control Levers (Figure 4-2).** Located under the seat, on the hydraulic pumps, used to "free-wheel" the mower. Rotating the levers clockwise until they stop allows the unit to move under hydraulic power. The levers must be in this position during operation of the mower. Rotating the levers counterclockwise, one turn, allows the mower to be moved by hand (free-wheeling).

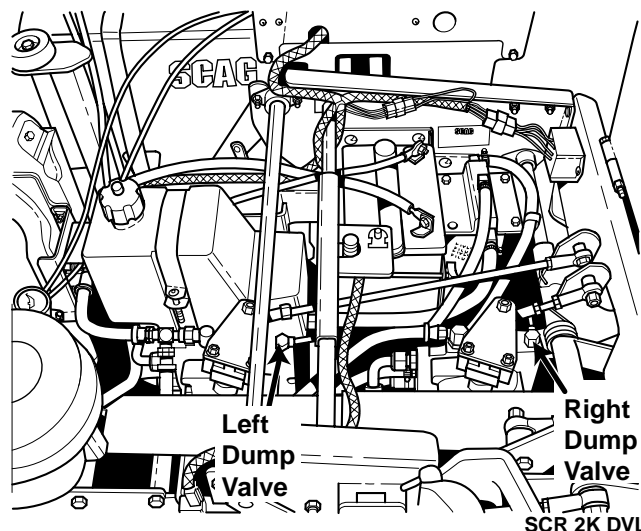

Figure 4-2 Dump Valves Location

14. **Blower Belt Release (Figure 4-3).** This lever is used to release the belt tension and allow the blower belt to be removed when the cutter deck is setup as either a mulching or a side discharge deck.

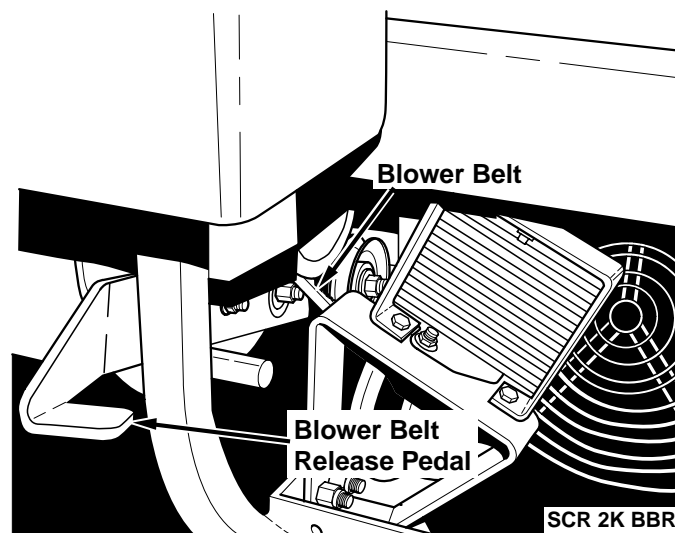

Figure 4-3 Blower Belt Release

4.2 SAFETY INTERLOCK SYSTEM

The mower is equipped with a safety interlock system that prevents the engine from starting unless the deck drive is disengaged and the speed control is in neutral and the parking brake is engaged. The interlock system shuts off the engine if the operator leaves the seat with the speed control in the neutral position and the parking brake is not engaged and/or the cutter blades are engaged. It will also shut the engine off if the cutter deck drive is engaged and the hopper is raised.



WARNING:

Never operate the mower with the interlock system disconnected or malfunctioning. Do not disengage or bypass any switch; injury to yourself and others or property damage could result.

4.3 INITIAL RUN-IN PROCEDURES (First Day of Use or Approximately 10 Hours)

1. Check all belts for proper alignment and wear after the initial 2, 4, and 8 hours of operation. The belt systems are self adjusting therefore tension adjustment is not necessary.
2. Change the engine oil and oil filter after the first 5 hours of operation. (See Section 7.4.)
3. Check hydraulic oil level in reservoir. (See Section 7.3.)
4. Check for loose hardware. Tighten as needed.
5. Check interlock system for proper operation. (See Section 4.2.)
6. Check tire pressure. Inflate tires if necessary.

4.4 STARTING THE ENGINE



CAUTION:

DO NOT USE STARTING FLUIDS. Use of starting fluids in the air intake system may be potentially explosive or cause a “runaway” engine condition that could result in engine damage and/or personal injury.

1. Be sure the fuel shutoff valve, located on top of the left fuel tank, is completely open. (See Section 7.4)
2. Sit in the operator’s seat and place the speed control in the neutral position and engage the parking brake.

3. If the engine is cold, adjust the engine choke as needed.
4. Adjust engine throttle control to about half engine speed.
5. Turn the ignition key to the START position and release the key as soon as the engine starts. Do not hold the key in the START position for more than 15 seconds at a time. Allow at least 60 seconds between each cranking attempt to prevent overheating of the starter motor. Prolonged cranking can damage the starter motor and shorten battery life.
6. Allow engine to warm before operating the mower.

4.5 GROUND TRAVEL AND STEERING

-IMPORTANT-

If you are not familiar with the operation of a machine with lever steering and/or hydrostatic transmissions, the steering and ground speed operations should be learned and practiced in an open area, away from buildings, fences, or obstructions. Practice until you are comfortable with the handling of the machine before attempting to mow. Learn the operation on flat ground before operating on slopes.

-IMPORTANT-

Start practice with a slow engine speed and slow forward travel.

Do not push the steering control levers forward when traveling forward. They are only used to steer the mower and to travel in reverse by pulling back on the levers.

Learn to operate the mower with the left hand on the steering levers and the right hand on speed control as shown in Figure 4-4. Using both hands on the steering levers often causes overcontrol.

Learn to feather the steering controls to obtain a smooth operating action. Jerky movements tend to place extreme force on the drive pumps and axles, as well as damage the lawns.

Practice operating the mower until you can make it go exactly where you are aiming.

Section 4

In case of an emergency, such as loss of control, stop the mower's movement by quickly pulling the forward speed control lever to the neutral position.

Forward Travel

-NOTE-

Use one hand on both steering levers as shown in Figure 4-4 to minimize overcontrol.

To travel forward with the mower, move the speed control lever forward. Do not push the steering control levers forward as they are used only for steering the mower left or right. When the speed control is moved forward, the mower will travel forward at the speed the control lever is set at. To increase the speed, push the control lever forward and to decrease the speed, pull the control lever back. It is not necessary to hold the speed control in position, since a friction system holds the lever in position.

To stop the forward travel, pull the speed control lever back to the neutral position.

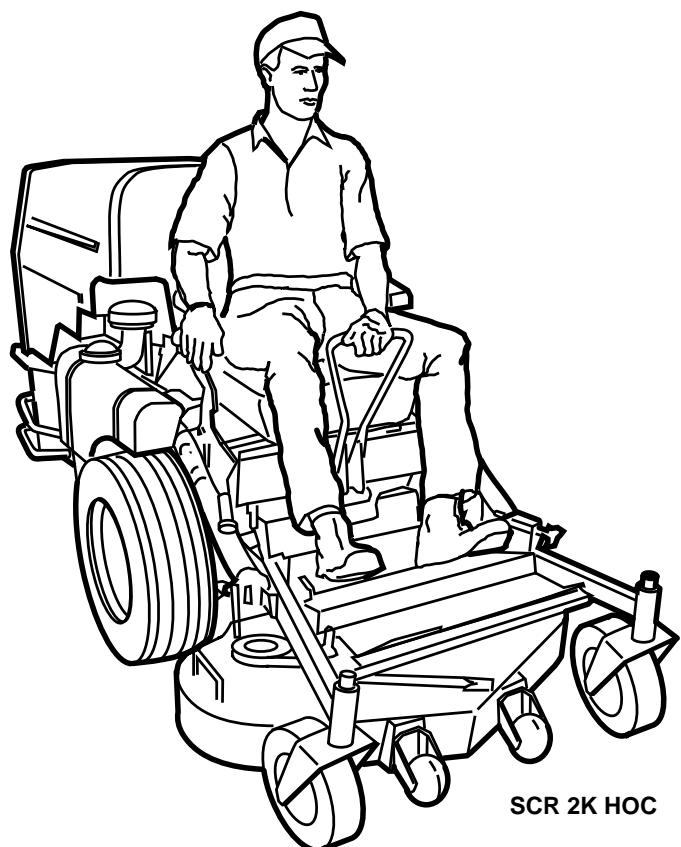

SCR 2K HOC

Figure 4-4 Hands On Controls

To steer the mower left while traveling forward, pull the left steering lever back. The further the lever is pulled back, the sharper the mower will turn left.

To steer the mower right while traveling forward, pull the right steering control lever back. The further the lever is pulled back, the sharper the mower will turn right.

-NOTE-

Smooth operation of the steering levers will produce a smooth mower operation. While learning the operation of the steering controls, keep the travel speed low.

-IMPORTANT-

Do not travel forward over a curb. The mower will hang up on the curb. Tilt the deck and travel backwards over the curb at a 45 degree angle. (See section 4.15 for cutter deck tilting instructions)

Reverse Travel

! CAUTION:

Before backing up, observe the rear for persons and obstructions. Clear the area before backing up. Possible injury or property damage could occur.

! CAUTION:

Disengage power to the mower before backing up. Do not mow in reverse unless absolutely necessary and then only after observation of the entire area behind the mower.

To travel in reverse, pull both handles all the way back. Keep the travel speed low while traveling in reverse.

-NOTE-

The mower will not travel straight in reverse. Slight adjustments must be made using the steering controls.

To steer left while traveling in reverse, allow the left steering control lever to move forward. The further the control is allowed to move forward, the sharper the mower will turn left.

To steer right while traveling in reverse, allow the right steering control lever to move forward. The further the control is allowed to move forward, the sharper the mower will turn right.

To stop the reverse travel, place the speed control lever in the neutral position and allow the steering control levers to return to the neutral position. If the mower is to be parked, engage the parking brake and remove the ignition key.

4.6 ENGAGING THE DECK DRIVE (CUTTER BLADES)

1. Set the throttle at about 3/4 speed. Do not attempt to engage the deck drive at high speed — use only moderate engine speed when engaging the deck drive.
2. Engage the deck drive by pushing the Cutter Deck Control Lever forward, (Figure 4-6) to the engage position.

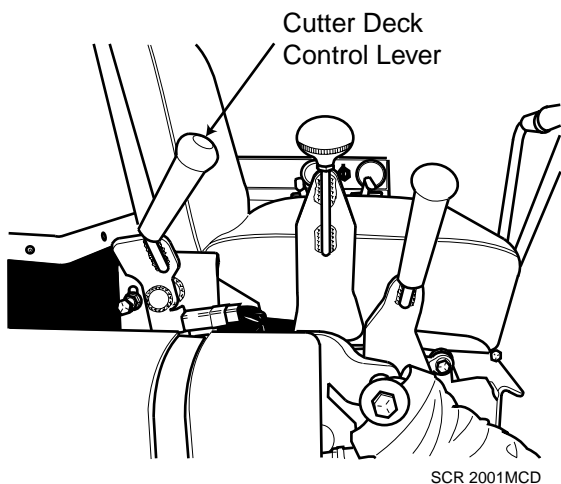

Figure 4-5 Cutter Deck Control Lever

3. To disengage the deck drive, pull back the Cutter Deck Control Lever to the disengage position.
4. Always operate the engine at full throttle to properly maintain cutting performance. If the engine starts to lug down, reduce the forward speed and allow the engine to operate at maximum RPM.

4.7 HILLSIDE OPERATION

WARNING:

To minimize the possibility of overturning, the least dangerous method of operating on hills and terraces is to travel vertically up and down the slope, not horizontally along the slope. Avoid any unnecessary turns and travel at reduced speed.

1. The mower has been designed for good traction and stability under normal mowing conditions. However, caution must be used when traveling on slopes, especially when the grass is wet. Wet grass reduces traction and steering control.
2. To inhibit tipping or loss of control, do not start or stop suddenly, avoid unnecessary turns and travel at reduced speed.
3. Keep tires properly inflated.
4. Always travel up or down the slope, whenever possible; NEVER across the slope. (See Figures 4-6 and 4-7.)

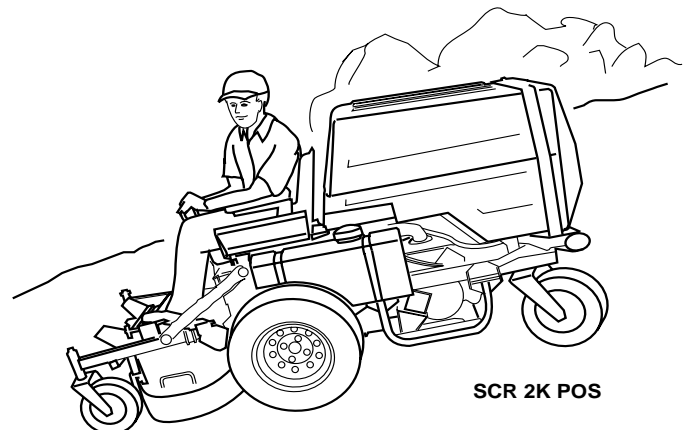

Figure 4-6 Proper Operation on a Slope

Section 4

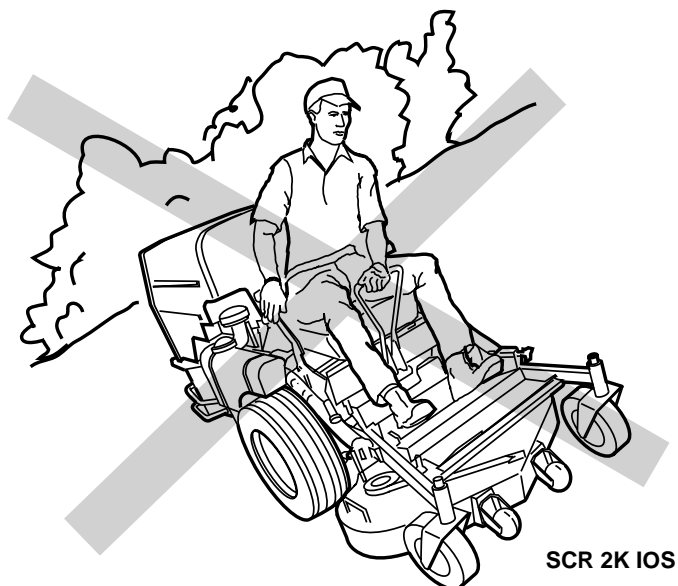

Figure 4-7 Improper Operation on a Slope

4.8 PARKING THE MOWER

1. Place the speed control in the neutral position.
2. Slow the engine to idle speed.
3. Engage the parking brake.
4. Turn the ignition key to the OFF position and remove the key.

4.9 AFTER OPERATION

1. Wash the entire mower after each use. Do not use high pressure spray or direct the spray onto electrical components.

-IMPORTANT-

Do not wash a hot or running engine. Cold water will damage the engine. Use compressed air to clean the engine if it is hot.

2. **Keep the entire mower clean** to inhibit serious heat damage to the engine or hydraulic oil circuit.
3. Check the drive belts for proper alignment, correct if necessary. Remove any debris build up.

4. Fill the fuel tank with fresh, clean fuel at the end of every day of operation.
5. Check the tire pressure. Inflate tires if necessary.

4.10 HOPPER, MULCH or SIDE DISCHARGE OPERATION

When mowing with the cutting deck setup for rear discharge into the hopper (Figure 4-9), the blower belt must be installed. A control lever located on the left side of the tractor (Figure 4-8) will release tension on the idler pulley to allow the belt to be installed (grass catching operation) or removed (mulching or side discharge operations). The cutter deck must also be adapted to the type of cutting that the operator is attempting to perform.

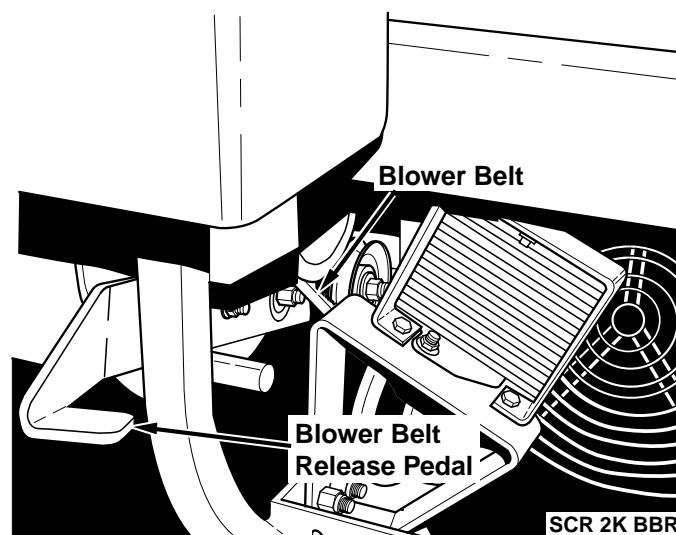

Figure 4-8 Blower Belt Release

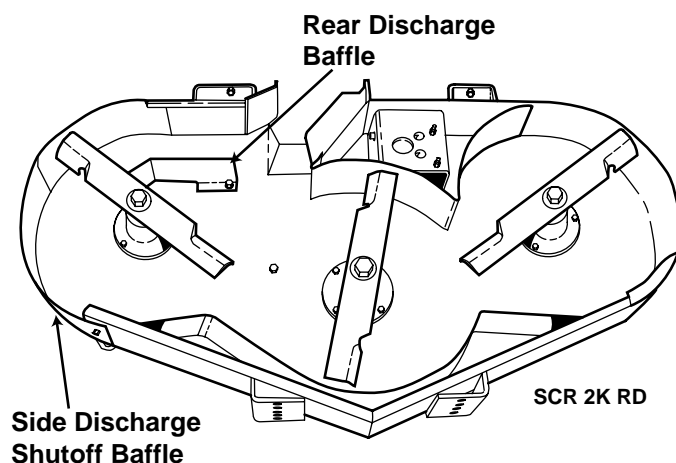

Figure 4-9 Baffles for Rear Discharge

Grass Catching Operation

CAUTION:

Never leave grass clippings in the hopper after mowing. Wet or damp clippings will generate heat as they decompose which may cause spontaneous combustion to occur.

1. With the hopper lowered, engage the deck drive. When the deck drive is engaged, the grass delivery spout, which is designed to distribute the grass clippings through the inside of the hopper, will begin to oscillate.

-NOTE-

The mower has an interlock switch that will prevent the mower from starting if the hopper is in the raised position. This interlock switch will also shut the engine off if the hopper is raised while the engine is running and the deck drive is engaged.

2. Proceed to mow the lawn until the hopper is full. If your mower is not equipped with the optional hopper fill alarm to tell you when the hopper is full, check the hopper frequently when first using the grass catcher. After operating with the grass catcher for awhile, experience will tell you when the hopper is full.

4. When dumping the hopper into a disposal area:

- A. Disengage the deck drive.

WARNING:

Never operate the grass catcher with the hopper back door open. Objects can be thrown out the spout of the hopper with a force that can cause injury to bystanders or property damage.

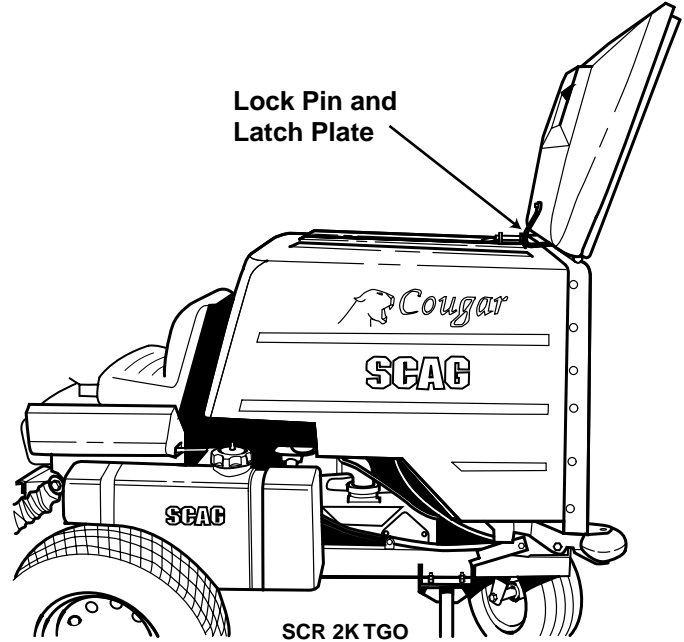

Figure 4-10 Tailgate Operation

- B. Raise the tailgate until the lock pin on top of the hopper engages with the latch on the tailgate (Figure 4-10).

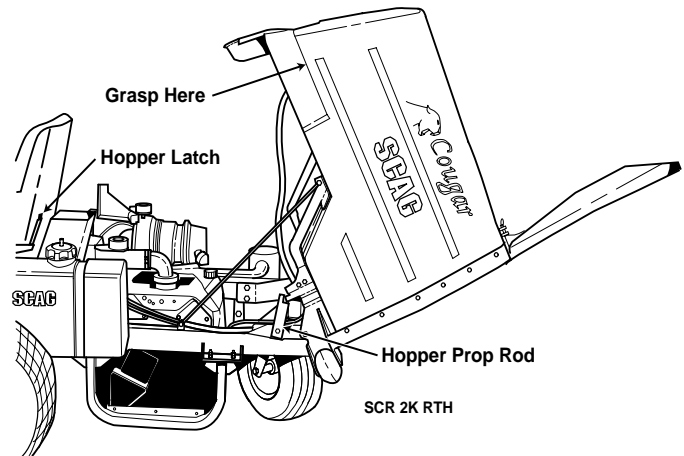

Figure 4-11 Raising The Hopper

- C. Stand off to side of the hopper. Unhook the hopper latch and raise the hopper by placing a hand in the hand hole at either bottom front side of the hopper (Figure 4-11) and then carefully lift the hopper until it is in its upright position. When service is needed under the hopper, rotate the hopper prop rod upward until it contacts the hopper frame. This will prevent the hopper from moving until the service is complete.
- D. Carefully lower the hopper and hook the hopper latch.

Section 4

- E. Release the latch holding the tailgate and then lower the tailgate.

Side Discharge Operation

CAUTION:

The side discharge deck can throw objects with great force. Do not stand in front of discharge chute when the cutter deck is engaged. Keep bystanders clear from the area while mowing.

When mowing, never discharge toward bystanders or buildings. Do not allow anyone near the machine while in operation.

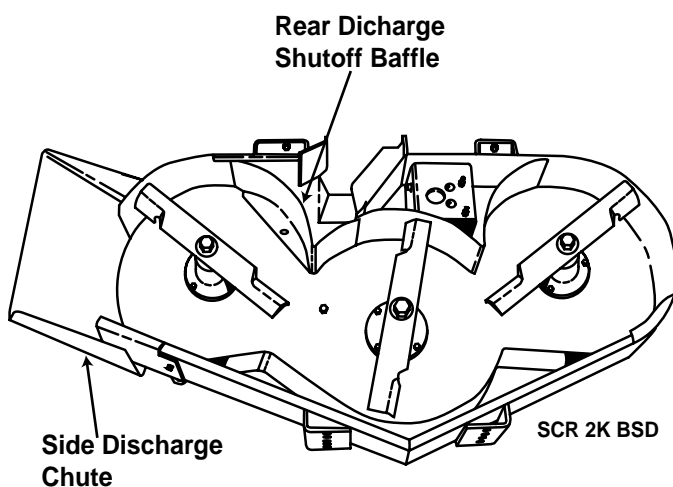

Figure 4-12 Baffles for Side Discharge

WARNING

DO NOT OPERATE WITHOUT DISCHARGE CHUTE, MULCHING KIT, OR ENTIRE GRASS CATCHER INSTALLED 482165

1. Place the proper baffles in the cutter deck and install the side discharge chute (Figure 4-12).
2. Release the tension from the blower belt and remove the blower belt. (Figure 4-8, Page 15).
3. Engage the deck drive.
4. Proceed to mow the lawn.

Mulching Operation

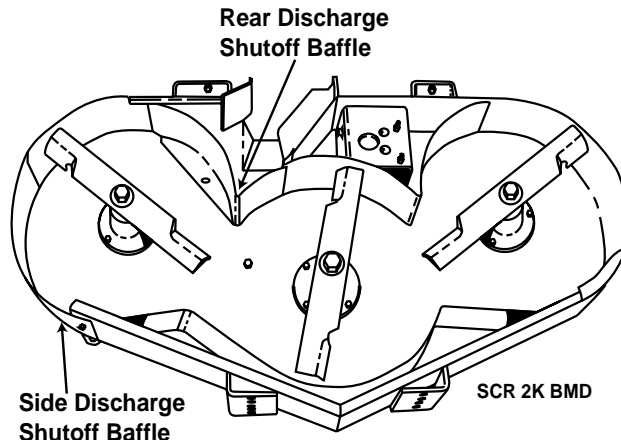

Figure 4-13 Baffles for Mulching

1. Place the proper baffles in the cutter deck for mulching operation (Figure 4-13).
2. Release the tension from the blower belt and remove the blower belt. (Figure 4-8, Page 15).
3. Engage the deck drive.
4. Proceed to mow the lawn.

4.11 REMOVING CLOGGED MATERIAL

DANGER:

ROTATING BLOWER BLADES
NEVER PUT YOUR HANDS INTO THE BLOWER DISCHARGE CHUTE FOR ANY REASON! Shut off the engine and remove the key and only then use a stick or similar object to remove material if clogging has occurred.

1. If either blower discharge chute becomes clogged, shut off the engine and remove the ignition key. Using a stick or similar item, dislodge the clogged material. Then resume normal mowing.

4.12 MOVING MOWER WITH ENGINE STOPPED

To “free-wheel” or move the mower around without the engine running, place the dump valve handle in the FREE-WHEEL position (Figure 4-2, Page 11). Disengage the parking brake and move the mower by hand. The lever must be returned to the DRIVE position to drive the mower.

4.13 RECOMMENDATIONS FOR MOWING

1. Do not mow with dull blades. A dull blade will tear grass, resulting in poor lawn appearance and requiring extra power.
2. Direct the side discharge away from sidewalks or streets to minimize cleanup of clippings. When mowing close to obstacles, direct the discharge away from the obstacles to reduce the chance of property damage by thrown objects.
3. Cut grass when it is dry and not too tall. Do not cut grass too short (cut off 1/3 or less of existing grass for best appearance). Mow frequently.
4. Keep mower and discharge system clean.
5. When mowing wet or tall grass, mow the grass twice. Raise the mower to the highest setting for the first pass and then make a second pass to the desired height.
6. Use a slow travel speed for trimming purposes.
7. Operate the engine at or near full throttle for best cutting. Mowing with a lower RPM causes the mower to tear the grass. The engine is designed to be operated at full speed.
8. Use the alternate stripe pattern for best lawn appearance. Vary the direction of the stripe each time the grass is mowed to avoid wear patterns in the grass.

4.14 ADJUSTING CUTTING HEIGHT

The mower deck can be adjusted from a height of 1 1/2-inches to 5-inches at 1/2-inch intervals. To adjust the cutting height:

! WARNING:

Do not adjust the cutting height with the mower blades rotating. Shut off the engine and remove the ignition key. Bodily injury could occur from the rotating blades.

1. Shut off the engine and remove the ignition key.

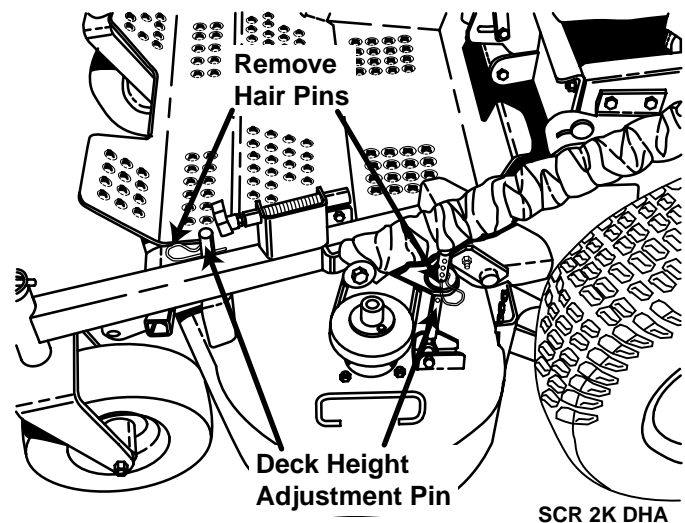

Figure 4-14 Deck Height Adjustment

2. Remove the two hairpins from the adjusting pins on one side of the cutter deck (Figure 4-14).
3. Lift or lower the deck to the desired cutting height and install the hairpins. A deck height decal is located on the deck as an aid in adjusting the deck to the desired height.
4. Repeat the above process on the other side of the cutter deck.

Section 4

4.15 TILTING THE CUTTER DECK

WARNING:

Do not tilt the mower deck with the mower blades rotating. Shut off the engine and remove the ignition key. Bodily injury could occur from the rotating blades.

The mower deck can be tilted up for trailering, blade replacement, etc. To tilt the deck up:

1. Shut off the engine, remove the ignition key and engage the park brake.

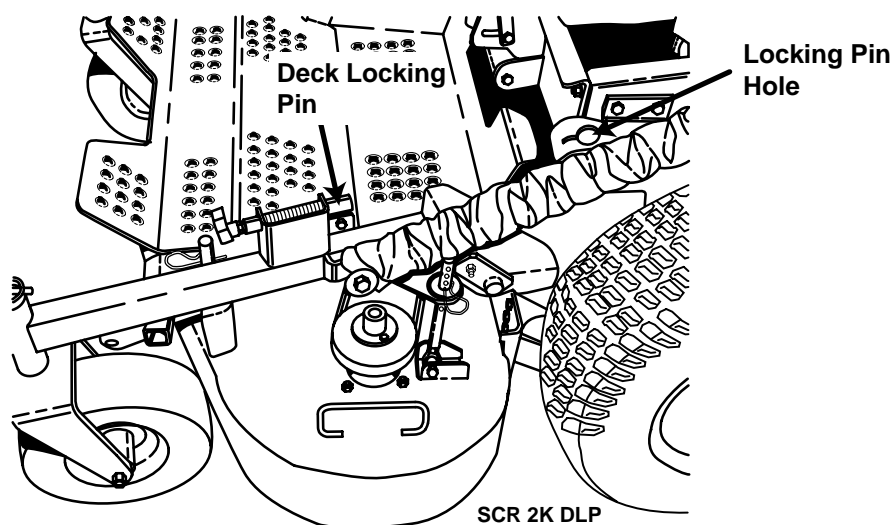
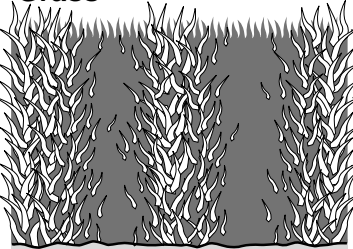
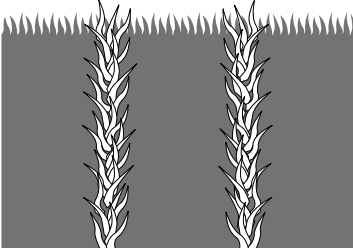
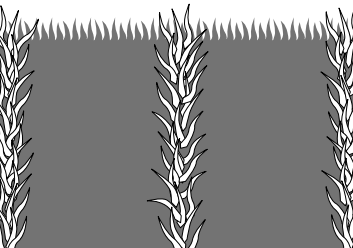

Figure 4-15 Deck Locking Pin

2. Lift up on the caster wheel arm until the lock pin engages into the lock pin hole (Figure 4-15).
3. To release the deck and lower it to its operating position:
 - A. Lift up on the caster wheel arm while pulling up on the lock pin.
 - B. Carefully lower the deck to the ground.

TROUBLESHOOTING CUTTING CONDITIONS

CONDITION	CAUSE	CURE
<p>Stringers - Occasional Blades of Uncut Grass</p> 	Low engine RPM	Run engine at full RPM
	Ground speed too fast	Slow speed to adjust for conditions
	Wet grass	Cut grass after it has dried out
	Dull blades, incorrect sharpening	Sharpen blades
	Deck plugged, grass accumulation	Clean underside of deck
	Belts slipping	Adjust belt tension
<p>Streaking - Strips of Uncut Grass in Cutting Path</p> 	Dull, worn blades	Sharpen blades
	Incorrect blade sharpening	Sharpen blades
	Low engine RPM	Run engine at full RPM
	Belt slipping	Adjust belt tension
	Deck plugged, grass accumulation	Clean underside of deck
	Ground speed too fast	Slow speed to adjust for conditions
	Wet grass	Cut grass after it has dried out
	Bent blades	Replace blades
<p>Streaking - Strips of Uncut Grass Between Cutting Paths</p> 	Not enough overlapping between rows	Increase the overlap of each pass

TROUBLESHOOTING (CONT'D)

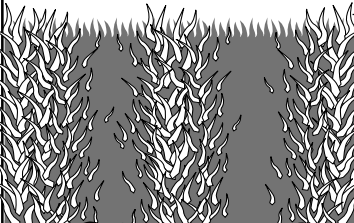
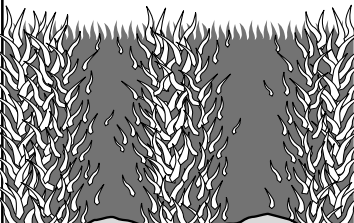
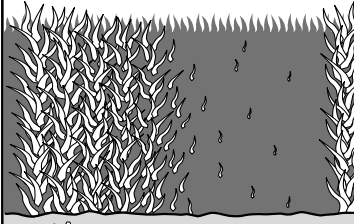
CONDITION	CAUSE	CURE
<p>Uneven Cut on Flat Ground - Wavy High-Low Appearance, Scalloped Cut, or Rough Contour</p>  <p>Width of Deck SGB020</p>	Lift worn from blade	Replace blade
	Blade upside down	Mount with cutting edge toward ground
	Deck plugged, grass accumulation	Clean underside of deck
	Too much blade angle (deck pitch)	Adjust pitch and level
	Deck mounted improperly	See your authorized SCAG dealer
	Bent spindle area	See your authorized SCAG dealer
	Dull blade	Sharpen blade
<p>Uneven Cut on Uneven Ground - Wavy Appearance, High-Low Scalloped Cut, or Rough Contour</p>  <p>Width of Deck SGB021</p>	Uneven ground	May need to reduce ground speed, raise cutting height, and/or change direction of cut
<p>Sloping Ridge Across Width of Cutting Path</p>  <p>Width of Deck SGB023</p>	Tire pressures not equal	Check and adjust tire pressure
	Wheels uneven	Check and adjust tire pressure
	Deck mounted incorrectly	See your authorized SCAG dealer
	Deck not level side-to-side	Check for level and correct

TROUBLESHOOTING (CONT'D)

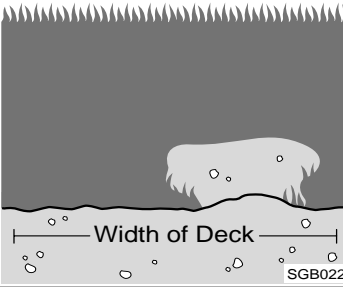
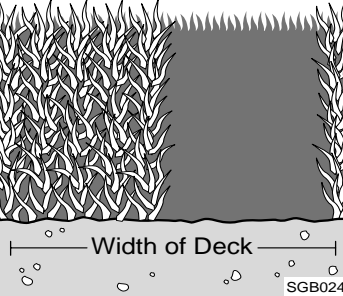
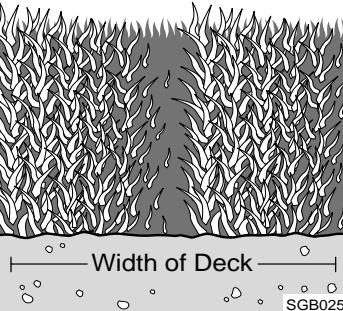
CONDITION	CAUSE	CURE
<p>Scalping - Blades Hitting Dirt or Cutting Very Close to the Ground</p>  <p>Width of Deck SGB022</p>	Low tire pressures	Check and adjust pressures
	Ground speed too fast	Slow speed to adjust for conditions
	Cutting too low	May need to reduce ground speed, raise cutting height, change direction of cut, and/or change pitch and level
	Rough terrain	May need to reduce ground speed, raise cutting height, and/or change direction of cut
	Ground speed too fast	Slow speed to adjust for conditions
<p>Step Cut - Ridge in Center of Cutting path</p>  <p>Width of Deck SGB024</p>	Blades not mounted evenly	Adjust pitch and level
	Bent blade	Replace blade
	Internal spindle failure	See your authorized SCAG dealer
	Mounting of spindle incorrect	See your authorized SCAG dealer
<p>Slope Cut - Sloping Ridges Across Width of Cutting Path</p>  <p>Width of Deck SGB025</p>	Bent spindle mounting area	See your authorized SCAG dealer
	Internal spindle failure	See your authorized SCAG dealer
	Bent deck housing	See your authorized SCAG dealer

ADJUSTMENTS

6.1 PARKING BRAKE ADJUSTMENT

! WARNING:

Do not operate the mower if the parking brake is not operable. Possible severe injury could result.

The parking brake linkage should be adjusted whenever the parking brake lever is placed in the “ENGAGE” position and the parking brake will not prevent the mower from moving. If the following procedures do not allow you to engage the parking brake properly, contact your Scag dealer for further brake adjustments.

1. Position a floor jack under the left side of the machine behind the drive wheel. Raise the machine and support it to prevent it from falling. Block the caster wheels to prevent the machine from moving. Remove the right drive wheel and reinstall (2) lug nuts to hold the hub on.
2. With the brake lever in the engaged position, check to see if the lever plunges the brake switch within 1/8" of bottoming out. (See Figure 6-1). To increase the distance, loosen the jam nuts on the parking brake control rod and turn the rod clockwise. To decrease the distance, turn the rod counterclockwise. (See Figure 6-2).

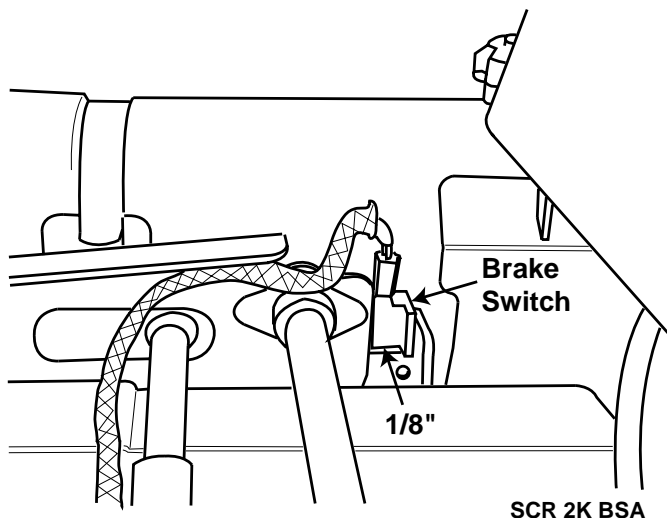

Figure 6-1 Brake Switch

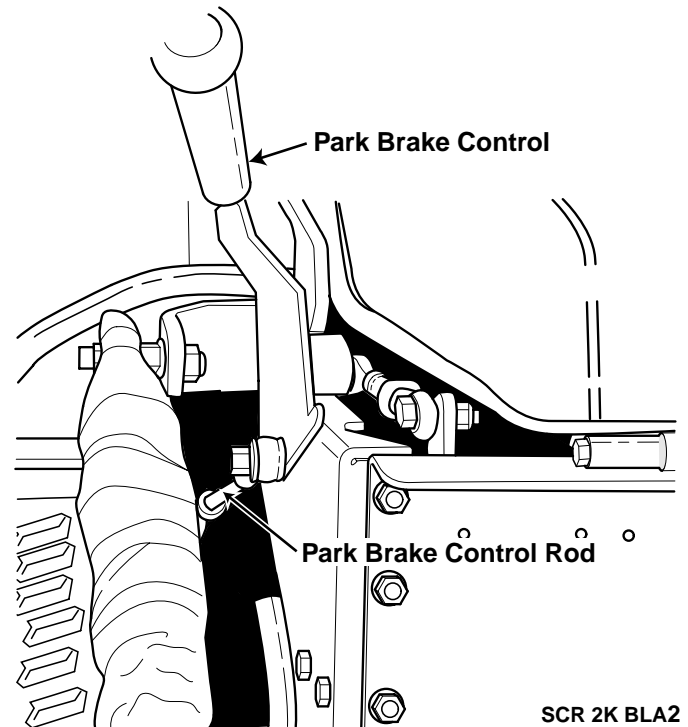

Figure 6-2 Brake Switch Adjustment

3. With the brake in the engaged position, check the distance between the lower nut on the brake actuator rod and the spring housing. The distance should be approximately 1/16". (See Figure 6-3).
4. Turn the nut at the top of the brake connector link until the 1/16" measurement is achieved and tighten the jam nut at the connector link on the brake actuator rod. (See Figure 6-3).
5. Repeat steps 3 and 4 on other side. Replace the drive wheels and test the brake.

-NOTE-

If this procedure does not achieve proper brake adjustment, please contact your authorized Scag dealer for diagnosis and repair.

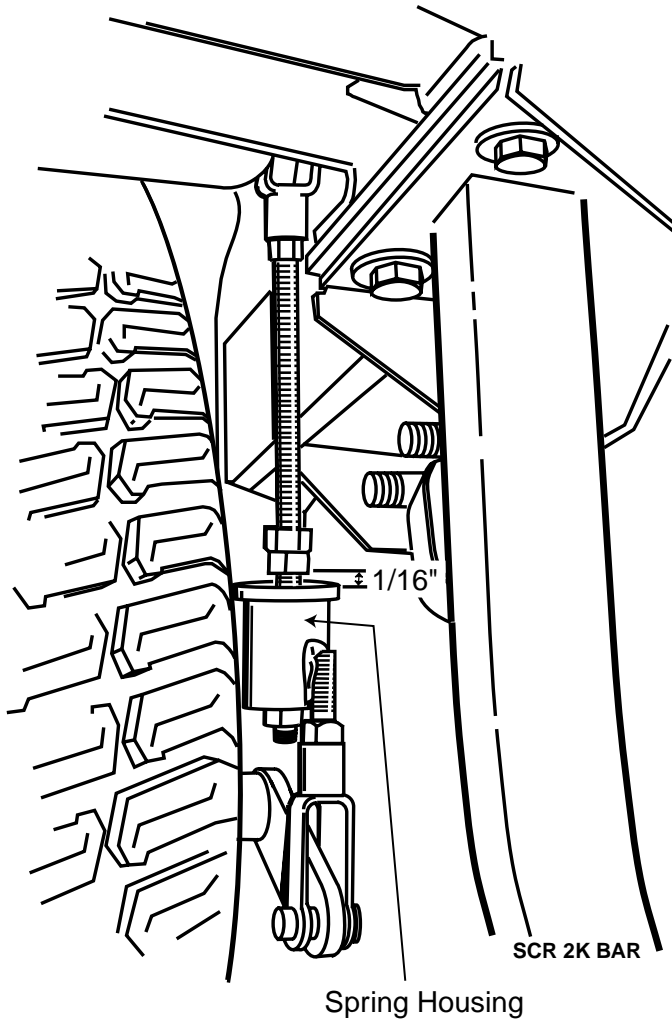

Figure 6-3 Brake Actuator Rod Assembly

6.2 TRAVEL ADJUSTMENTS

Neutral or tracking adjustments will need to be made if:

- A. The speed control lever is in neutral and the machine creeps forward or backward. (Neutral Adjustment)
- B. The mower pulls to one side or the other when traveling in a forward direction. (Tracking Adjustment).

If the mower creeps forward or backward as indicated in "A" above, the neutral linkages must be adjusted. Start with adjusting the speed control lever and proceed as directed. To correct the tracking of the mower (mower pulls to one side when traveling in a forward direction), adjust the tracking of the mower as described on page 23.

! CAUTION:

Stop the engine and remove the key from the ignition before making any adjustments. Wait for all moving parts to come to a complete stop before beginning work.

! CAUTION:

The engine and drive unit can get hot during operation causing burn injuries. Allow engine and drive components to cool before making any adjustments.

Neutral Adjustment

-IMPORTANT-

Before proceeding with this adjustment, be sure that the tire pressure is correct, that the caster wheels turn freely, and that the transmission drive belt tension spring is not broken.

1. Jack up the machine enough to lift the drive wheels and block securely.
2. Pull the speed control lever into the neutral position.
3. Pull the park brake lever into the fully engaged position.
4. Adjust the speed control lever turnbuckle until the speed control lever contacts the park brake lever and tighten the jam nuts. (See Figure 6-4).

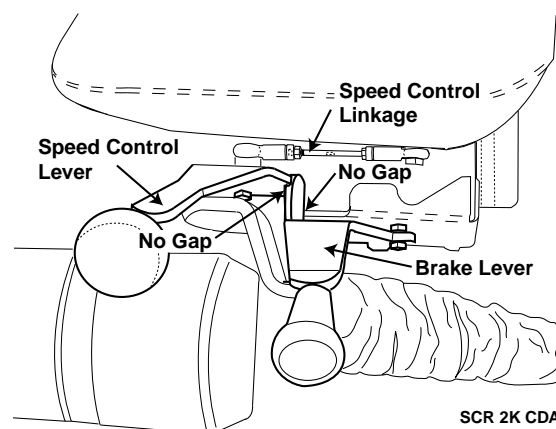

Figure 6-4 Speed Control Lever

IMPORTANT ADJUSTMENT PROCEDURES
READ OPERATOR'S MANUAL FOR MORE DETAILS

Check tire pressure - (Drive tires - 12 PSI, ALL others - 25 PSI)

NEUTRAL ADJUSTMENT
Adjust neutral only with drive wheels elevated and machine blocked securely. With speed control lever turnbuckle set at 5.5", pull speed control lever back to neutral. Apply brake and adjust turnbuckle until speed control lever contacts brake lever. When completed, neutral can be adjusted on machine. If wheels rotate forward when brake is released, adjust control rods CCW. If wheels rotate rearward, adjust control rods CW.

TRACKING ADJUSTMENT (Be sure both drive tires are inflated equally)
If machine pulls to right, loosen jam nuts C & D on RH control rod and turn rod CW, tighten jam nuts and retest. If machine pulls to left, loosen jam nuts A & B on LH control rod and turn rod CW, tighten jam nuts and retest.

ALL gearbox Lubricant:
SAE 80W90 Gear Oil

IMPORTANT
GREASE SPINDLE, DRIVESHAFT
AND BLOWER BEARINGS WEEKLY
LITHIUM MP WHITE GREASE 2125

HYDRAULIC TANK FLUID LEVEL
Check hydraulic fluid level daily while fluid is cool. Fluid level should be 2-1/2" below top of filler neck. Fill with SAE 20W50 motor oil only.

IMPORTANT!:
Do not overfill. Room for hot fluid expansion must be allowed or resulting expansion may cause leaks in the system.

FREE WHEEL OPERATION
To move machine without running the engine, rotate both dump valve levers located at the front of the pumps CCW 1/2 turn to "freewheel" positions. Return levers to original position to operate the mower.

482052

Figure 6-5 Drive linkage

SCR 2KTAD

5. Start the engine and disengage the parking brake.
6. Loosen jam nuts C and D (See Figure 6-5) on the right side. Slowly rotate the control rod until the right drive wheel starts to creep forward. When the wheel starts to creep forward, stop the movement and turn the control rod back until the wheel starts to creep in reverse. When the wheel starts to creep in reverse, stop the movement and turn the control rod to the center point between forward and reverse motion (Figure 6-4) and tighten the jam nuts.
7. Loosen jam nuts A and B (See Figure 6-5) on the left side. Slowly rotate the control rod until the left drive wheel starts to creep forward. When the wheel starts to creep forward, stop the movement and turn the control rod back until the wheel starts to creep in reverse. When the wheel starts to creep in reverse, stop the movement and turn the control rod to the center point between forward and reverse motion (Figure 6-5) and tighten the jam nuts.
8. Remove the blocking and lower the drive wheels to the ground.
9. When the speed control lever is actuated, the mower should travel in a straight line. If it does not travel straight, perform the Tracking Adjustment procedures.

Tracking Adjustment

-IMPORTANT-

Before proceeding with this adjustment, be sure that the tire pressure is correct, that the caster wheels turn freely, and that the transmission drive belt tension spring is not broken.

The mower tracking should be adjusted if the machine does not travel in a straight line during forward travel. Perform the neutral adjustment before proceeding with the tracking adjustment.

1. If the machine pulls to the right, loosen the jam nuts on the right control rod and turn the rod slightly clockwise, tighten the jam nuts and retest.
2. If the machine pulls to the left, loosen the jam nuts on the left control rod and turn the rod slightly clockwise, tighten the jam nuts and retest.

Cutter Deck Engagement Belt Adjustment

This adjustment should be made after the initial break in (first 8 Hours of operation) and checked every 40 hours thereafter.

1. Check the tension on the belt. (See Figure 6-6). There should be 1/2" deflection with 10lbs. of force at the longest span between pulleys.
2. To increase or decrease the belt tension, loosen the jam nuts on the control rod and turn until the proper belt tension is achieved. (See Figure 6-6)

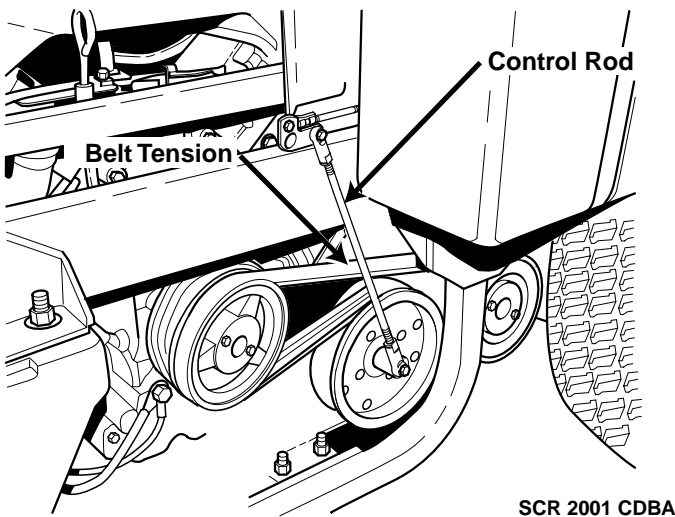

Figure 6-6 Engagement Belt Adjustment

Steering Handle Adjustment

The steering handles should be positioned in line with each other for easy one-handed control. (See Figure 6-7). The handles can then be adjusted forward or backwards to accommodate the operator.

1. Shut off the mower's engine and engage the parking brake.
2. Loosen the two bolts for each steering handle and pivot the handles forward or back as desired.
3. Keep the handles aligned and tighten the bolts.

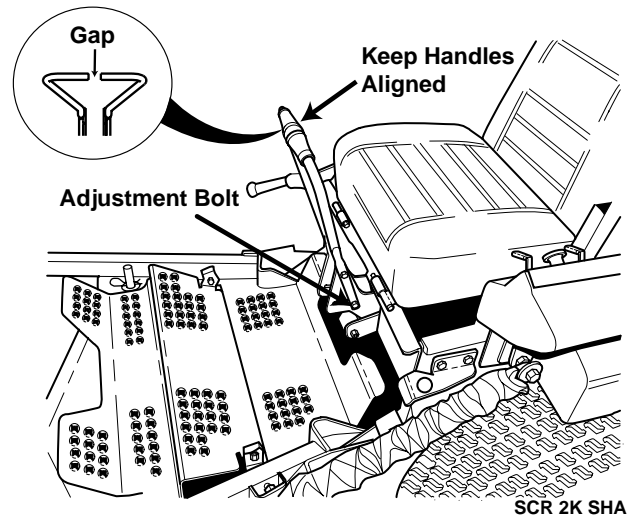

Figure 6-7 Steering Handle Adjustment

4. Maintain gap between steering handles. If gap does not exist, contact your authorized Scag service center.

6.3 THROTTLE CONTROL AND CHOKE ADJUSTMENT

These adjustments must be performed by your Scag dealer to ensure proper and efficient running of the engine. Should either need adjustment, contact your authorized Scag service center.

! WARNING:

Before removing any guards, shut the engine off and remove the ignition key.

6.4 BELT ADJUSTMENT

All drive belts and cutter deck belts are spring loaded and self-tensioning. The belts should be checked periodically for proper alignment and wear.

6.5 BELT ALIGNMENT

Belt alignment is important for proper performance of your Scag mower. If you experience frequent belt wear or breakage, see your authorized Scag service center for belt adjustment.

Section 6

6.6 CUTTER DECK ADJUSTMENTS

The mower deck can be adjusted from a height of 1-1/2-inches to 5-inches at 1/2-inch intervals. To adjust the cutting height:

5. Cutter deck pitch is adjusted by loosening the locknut on each of the front cutter deck height adjuster pins and turning the pins until 1/4" pitch (front edge of cutter deck is 1/4" lower than the rear edge of the cutter deck) is achieved. Tighten the locknuts securely once the proper adjustment has been set.



WARNING:

Do not adjust the cutting height with the cutter blades rotating. Shut the engine off and remove the key from the ignition. Bodily injury could occur from the rotating blades.

1. Shut off the engine and remove the key from the ignition.
2. Remove the hairpins from the adjusting pins on one side of the cutter deck. (See Figure 6-8).
3. Lift or lower the deck to the desired cutting height by using the handles supplied on the cutter deck. (See Figure 6-8). Reinstall the hairpins at the desired cutting height. A deck height decal is located on the deck mounting frame as an aid in adjusting the deck to the desired height.
4. Repeat the above process for the other side of the cutter deck.

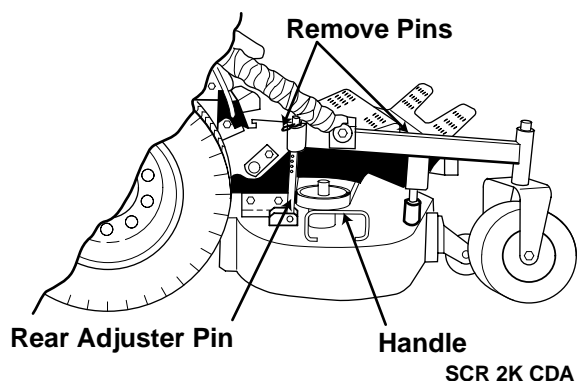

Figure 6-8 Cutter Deck Adjustment

WARNING:

NEVER engage the cutter deck without the belt cover in place.

MAINTENANCE

7.1 MAINTENANCE CHART - RECOMMENDED SERVICE INTERVALS

Break-In (First 10)	HOURS					Procedure	Comments
	8	40	100	200	500		
X						Check all hardware for tightness	
X						Check hydraulic oil level	See paragraph 7.3
X						Check all belts for tightness	See paragraph 7.8
X (First 5)						Change engine oil and filter	See paragraph 7.4
	X					Fill fuel tank before starting	Use unleaded gasoline with a minimum octane rating of 87
	X					Check engine oil level	See paragraph 7.4
	X					*Clean mower	See paragraph 7.14
	X					Check condition of blades	See paragraph 7.9
	X					Apply grease to fittings	See paragraph 7.2
	X					Clean screen in hopper	See paragraph 7.11
	X					*Check/clean air intake	See paragraph 7.6
	X					Check tire pressure	See paragraph 7.10
		X				Check battery electrolyte level, clean battery posts and cables	See paragraph 7.7
		X				Check belt	See paragraph 7.8
			X			Apply grease to fittings	See paragraph 7.2
			X			Change engine oil	See paragraph 7.4
			X			*Clean air cleaner element	See paragraph 7.6
			X			Check engine belts for wear	See paragraph 7.8
			X			Check lubricant in gearboxes	See paragraph 7.13

MAINTENANCE CHART - RECOMMENDED SERVICE INTERVALS (CONT'D)

Break-In (First 10)	HOURS					Procedure	Comments
	8	40	100	200	500		
				X		Apply grease to fittings	See paragraph 7.2
				X		Check hardware for tightness	
				X		Change engine oil filter	See paragraph 7.4
				X		Check hydraulic oil level	See paragraph 7.3
					X	Replace engine fuel filter	See paragraph 7.5
					X	Drain hydraulic system and replace hydraulic oil	See paragraph 7.3 Use SAE 20W50 Motor Oil
					X	Replace hydraulic oil filter	See paragraph 7.3
					X	Replace power unit gearbox lubricant	See paragraph 7.13
					X	Replace lubricant in cutter deck gear boxes	See paragraph 7.12

* Perform these maintenance procedures more frequently under heavy load, extreme dusty or dirty conditions.

7.2 LUBRICATION
**GREASE FITTING LUBRICATION CHART
(SEE FIGURE 7-1)**

LOCATION	LUBRICATION INTERVAL	LUBRICANT	NO. OF PLACES
1 Brake Linkage	100 Hours/Bi-Weekly	Chassis Grease	2
2 Caster Wheel Pivot	100 Hours/Bi-Weekly	Chassis Grease	2
3 Caster Wheel Bearings	100 Hours/Bi-Weekly	Chassis Grease	2
4 Cutter Deck Pivots	100 Hours/Bi-Weekly	Chassis Grease	2
5 Brake Lever	100 Hours/Bi-Weekly	Chassis Grease	1
6 Rear Wheel Bearings	100 Hours/Bi-Weekly	Chassis Grease	1
7 Cutter Deck Drive Shaft	50 Hours/Bi-Weekly	Chassis Grease	3
8 Steering Control Levers and Linkage	100 Hours/Bi-Weekly	Chassis Grease	4
9 Cutter Deck Spindles	40 Hours/Weekly	+Lithium MP White Grease 2125	3
10 Blower Bearing	8 Hours/Daily	+Lithium MP White Grease 2125	1
11 Cutter Deck Engagement Lever	40 Hours/Weekly	Chassis Grease	1
12 Elbow Pivot (Inside Hopper)	40 Hours/Weekly	Chassis Grease	1

- + Compatible Greases: Mobilix #2 found at Mobil Service Stations
- Ronex MP found at Exxon Service Stations
- Super Lube MEP #2 & Super Stay-M #2 found at Conoco Stations
- Shell Alvania #2 found at Shell Service Stations
- Lidok EP #2 found at industrial shops

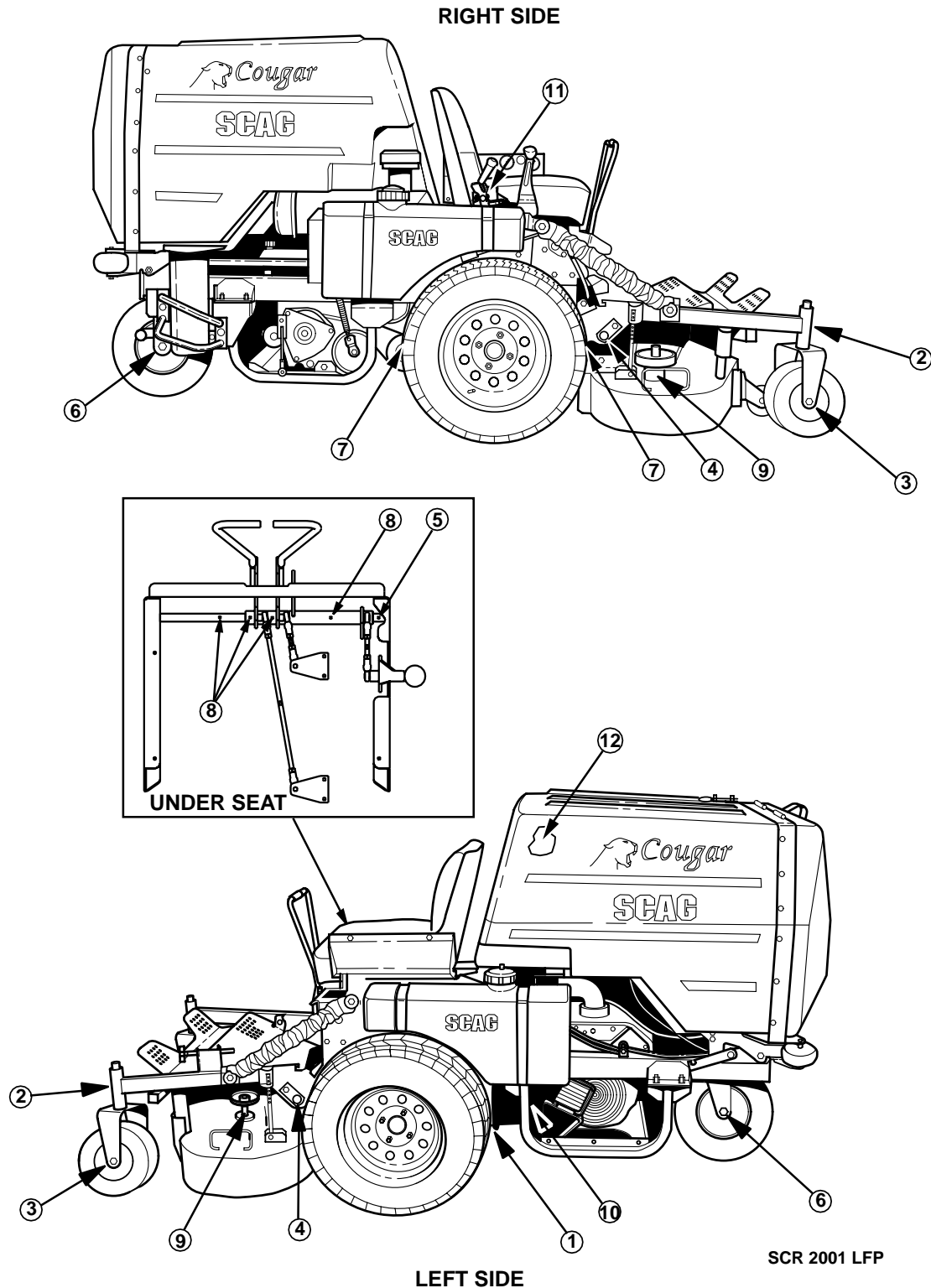

Figure 7.1 Lubrication Fitting Points

Section 7

7.3 HYDRAULIC SYSTEM

A. Checking Hydraulic Oil Level

The hydraulic oil level should be checked after the first 10 hours of operation. Thereafter, check the oil after every 200 hours of machine operation or monthly, whichever occurs first.

-IMPORTANT-

If the oil level is consistently low or leaks are noticed, check for leaks and correct immediately.

1. Wipe dirt and contaminants from around the reservoir cap. Remove the cap from the hydraulic oil reservoir.
2. Visually check the level of hydraulic oil. Hydraulic oil must be at least 2-1/4" inches from top of the filler neck. If the level cannot be determined visually, use a clean tape measure to check the level. If the fluid is low, add 20W50 motor oil. DO NOT overfill; (overfilling the oil reservoir may cause oil seepage).
3. Clean the fill cap and install it onto the reservoir.

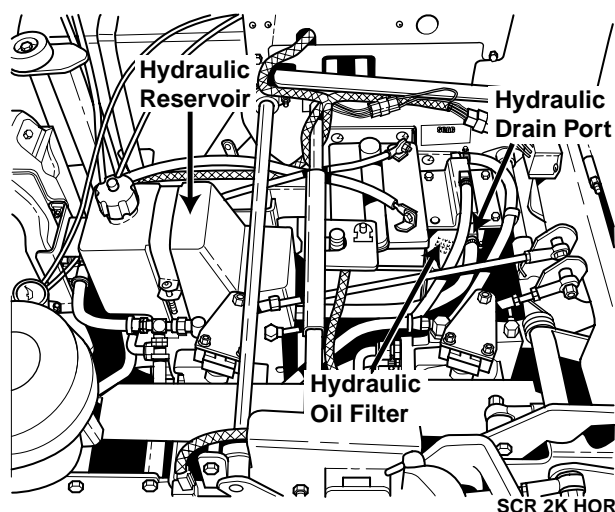

Figure 7-2 Hydraulic Oil Reservoir

B. Changing Hydraulic Oil

The hydraulic oil should be changed after every 500 hours or annually, whichever occurs first. The oil should also be changed if the color of the fluid has become black or milky.

A black color and/or a rancid odor usually indicates possible overheating of the oil, and a milky color usually indicates water in the hydraulic oil.

-Note-

The hydraulic oil should be changed if you notice the presence of water or a rancid odor to the hydraulic oil.

1. Park the mower on a level surface and stop the engine.
2. Place a suitable container under the hydraulic oil filter. Remove the cap from the tee installed in the hydraulic oil filter head. (Figure 7-2). Allow the fluid to drain into the container and properly discard it.
3. Remove the oil filter element (Figure 7-2) and properly discard it. Fill the new filter with clean oil and install the filter. Hand tighten only.
4. Install the cap onto the tee and be sure it is tight.
5. Remove the fill cap from the reservoir and fill the reservoir to 2-1/4" inches from the top of the filler neck with 20W50 motor oil.
6. Replace the reservoir fill cap.
7. Start the engine and drive forward and backward for two minutes. Check the oil level in the reservoir. If necessary, add oil to the reservoir.

7.4 ENGINE OIL

A. Checking Engine Crankcase Oil Level

The engine oil level should be checked after every 8 hours of operation or daily as instructed in the Engine Operator's Manual furnished with this mower.

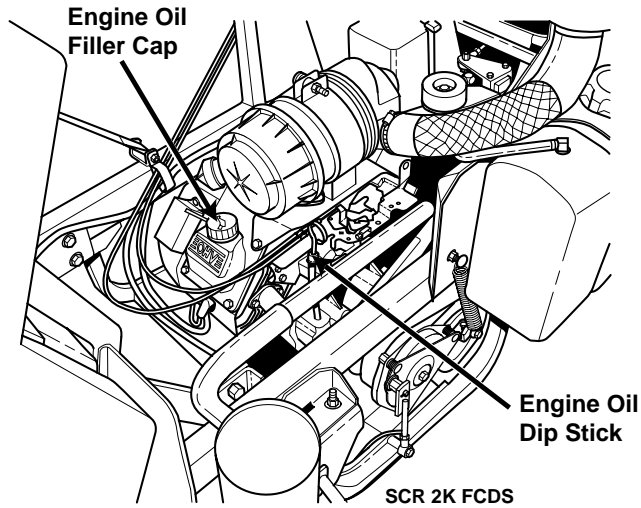

Figure 7-3 Engine Fill Cap and Dip Stick

B. Changing Engine Crankcase Oil

After the first 5 hours of operation, change the engine crankcase oil and replace the oil filter. Thereafter, change the engine crankcase oil after every 100 hours of operation or bi-weekly, whichever occurs first. Refer to the Engine Operator's Manual furnished with this mower for specific instructions.

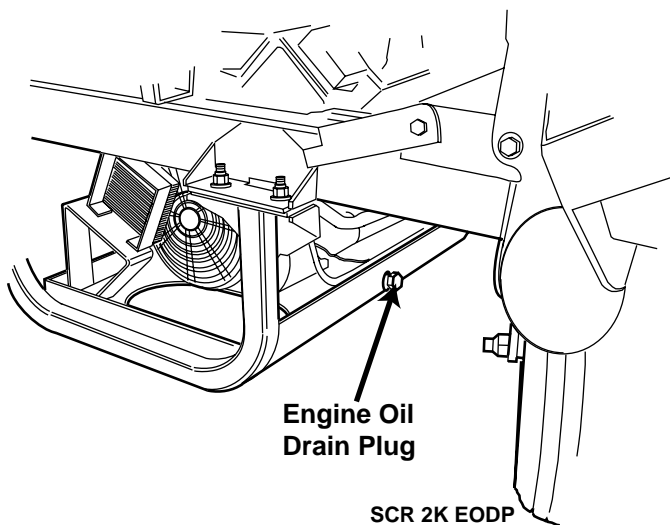

Figure 7-4 Engine Oil Drain Plug

C. Changing Engine Oil Filter

After the first 5 hours of operation, replace the engine oil filter. Thereafter, replace the oil filter after every 200 hours of operation or every month, whichever occurs first. Refer to Engine Operator's Manual for specific instructions.

7.5 ENGINE FUEL SYSTEM

! DANGER:

To avoid injury from burns, allow the mower to cool before removing the fuel tank cap and refueling.

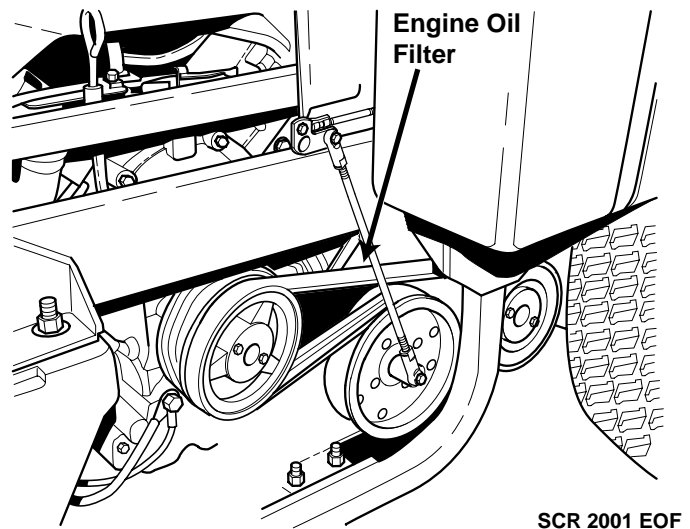

Figure 7-5 Engine Oil Filter

A. Filling the Fuel Tank

Fill the fuel tank at the end of each operating day to within 1 inch below the filler neck. Do not overfill. Use clean, fresh unleaded gasoline with a minimum octane rating of 87.

B. Replacing In-Line Fuel Filter Element

The in-line fuel filter (Figure 7-6) should be replaced after every 500 hours of operation or annually, whichever occurs first.

1. Close the shutoff valve. Remove the two clamps securing the fuel filter to the fuel hose. Remove the fuel filter.

Section 7

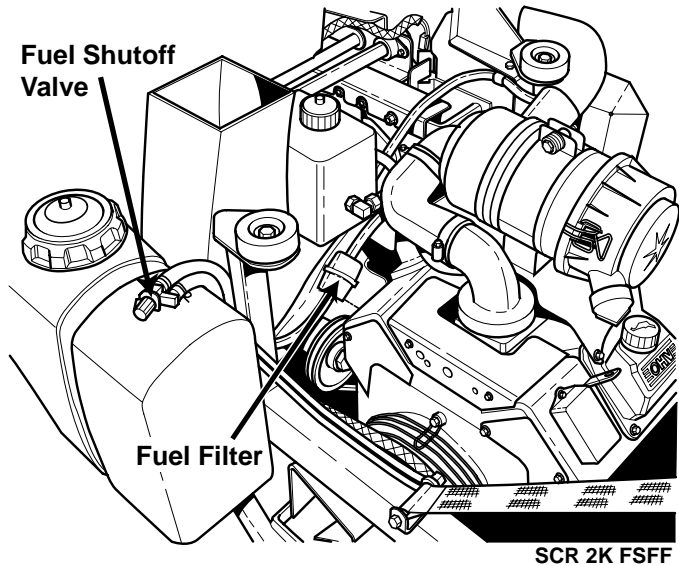

Figure 7-6 Fuel Shutoff and Fuel Filter

2. Install a new fuel filter. Be sure it is installed in the proper direction. Secure to the fuel hose using the two clamps. Wipe up any spilled gasoline and dispose of rags in an approved container.

7.6 ENGINE AIR CLEANER

A. Cleaning and/or Replacing Air Cleaner Element

For any air cleaner, the operating environment dictates the air cleaner service periods. Inspect and clean the air cleaner element after every 100 hours of operation or bi-weekly, whichever occurs first and replace the element if required.

-NOTE-

In extremely dusty conditions it may be necessary to check the element once or twice daily to prevent engine damage.

1. Remove the wing nut securing the air cleaner cover to the engine. Remove the air cleaner cover and set aside.
2. Remove the nut securing the clamping plate and the air cleaner to the engine. Remove the clamping plate and set aside. Remove the air cleaner and inspect.
3. Clean or replace the air cleaner and foam pre-cleaner as necessary.

4. Replace the air cleaner after six cleanings or after every 500 hours of operation or annually, whichever occurs first.

7.7 BATTERY

A. Checking Electrolyte Level and Cleaning Battery

After every 40 hours of operation or weekly, whichever occurs first, check the electrolyte level in the battery and clean the battery and connections. Dirt and fluid on the top of the battery can cause the battery to discharge. Corrosion of the battery terminals or loose connections will cause poor battery performance.

! WARNING:

Lead-acid batteries produce flammable and explosive gases. To avoid personal injury when checking, testing or charging batteries, DO NOT use smoking materials near batteries. Keep arcs, sparks and flames away from batteries. Provide proper ventilation and wear safety glasses.

! WARNING:

Electric storage battery fluid contains sulfuric acid which is POISON and can cause SEVERE CHEMICAL BURNS. Avoid contact of fluid with eyes, skin, or clothing. Use proper protective gear when handling batteries. DO NOT tip any battery beyond 45° angle in any direction. If fluid contact does occur, follow first aid suggestions below.

⚠️ WARNING:

BATTERY ELECTROLYTE FIRST AID

EXTERNAL CONTACT — Flush with water.

EYES — Flush with water for at least 15 minutes and get medical attention immediately.

INTERNAL — Drink large quantities of water. Follow with Milk Of Magnesia, beaten egg, or vegetable oil. Get medical attention immediately. In case of internal contact, DO NOT give fluids that would induce vomiting.

1. Tilt the seat forward to access the battery.
2. Remove the battery cell caps. Visually inspect electrolyte level in the cells. If electrolyte is below the bottom of vent well, fill with clean distilled water to the bottom of vent wells (1/4 to 1/2 inch above the plates). Install the battery cell caps.

-IMPORTANT-

Do not overfill the battery. Electrolyte will overflow through the vent tube onto parts of the machine, resulting in severe corrosion.

3. Clean the cable ends and battery posts with steel wool or a wire brush. Use a solution of baking soda and water to clean the battery. Do not allow the solution to enter the battery cells.
4. Tighten the cable connections securely and apply a light coat of silicone dielectric grease to the terminal connections to prevent corrosion.

B. Charging the Battery

Refer to the battery charger's manual for specific instructions.

Under normal conditions the engine's alternator will have no problem keeping a charge on the battery. If the battery has been completely discharged for a long period of time, the alternator may not be able to recharge the battery, and a battery charger will be required.

DO NOT charge a frozen battery. It may explode and cause injury. Let the battery warm before attaching a charger.

Whenever possible, remove the battery from the mower before charging and make sure the electrolyte covers the plates in all cells.

⚠️ WARNING:

BATTERIES PRODUCE EXPLOSIVE GASES. Charge the battery in a well ventilated space so gases produced while charging can dissipate.

Charging rates between 3 and 50 amperes are satisfactory if excessive gassing or spewing of electrolyte does not occur or the battery does not feel excessively hot (over 125°F). If spewing or gassing occurs or the temperature exceeds 125°F, the charging rate must be reduced or temporarily stopped to permit cooling.

C. Jump Starting

1. The booster battery must be a 12 volt type. If a vehicle is used for jump starting, it must have a negative ground system.
2. When connecting the jumper cables, connect the positive cable to the positive battery post, then connect the negative cable to the negative battery post.

Section 7

7.8 DRIVE BELTS

After the first 2, 4, 8 and 10 hours of operation, check for proper tension on all drive belts and check for any damage. Thereafter, check the belt tension after every 100 hours of operation or bi-weekly, whichever occurs first.

1. Check the belts for cracks, tears, and excessive wear. Replace any damaged belts.

7.9 CUTTER BLADES

A. Blade Inspection

1. Remove the ignition key before servicing the blades.
2. Tilt the mower deck and secure in place.

WARNING:

Never operate the cutter blades with the deck in the raised position because it is hazardous and damage to mower will result.

3. Check the blades for straightness. If the cutter blades appear bent, they will need to be replaced.

WARNING:

Do not attempt to straighten a bent blade, and never weld a broken or cracked blade. Always replace it with a new blade to assure safety.

4. If a blade cutting edge is dull or nicked, it should be sharpened. Remove the blades for sharpening. See "Blade Replacement."

-NOTE-

Keep the blades sharp. Cutting with dull blades not only yields a poor mowing job, but slows the cutting speed of the mower and causes extra wear on the engine and the blade drive.

B. Blade Sharpening

-NOTE-

DO NOT sharpen the blades beyond 1/3 of the width of the blade.

1. Sharpen the cutting edge at the same bevel as the original. See Figure 7-8. Sharpen only the top of the cutting edge to maintain sharpness.

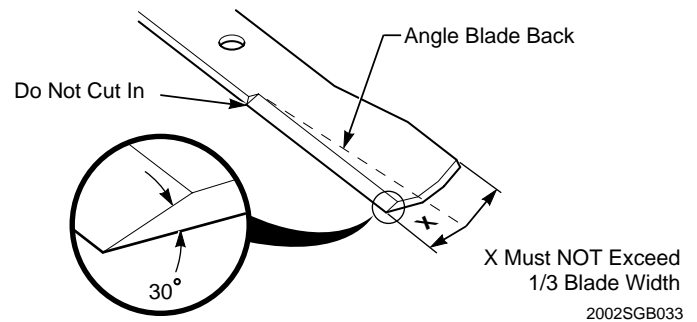

Figure 7-8 Blade Sharpening

2. Check the balance of the blade. If the blades are out of balance, vibration and premature wear can occur. See your authorized Scag dealer for blade balancing or special tools, if you choose to balance your own blades.

C. Blade Replacement

1. Remove the ignition key and engage parking brake before replacing the blades.
2. Tilt the mower deck and secure in place with lock pin.

-IMPORTANT-

Spindle blade bolts are left handed thread.

3. Secure the cutter blades to prevent them from rotating, (use the optional Blade Buddy tool, P/N 9212, to assist in securing the cutter blades), remove the nut from the blade attaching bolt. Remove the cutter blade, bolt and spacer from the spindle shaft.

4. To install the new blade, put the flat washer onto the blade bolt and slide the bolt into the hole in the cutter blade.
5. Install the spacer onto the blade bolt and insert the belt into the cutter spindle shaft.
6. Install the hex nut to the blade bolt at the top of the cutter spindle. Secure the blades from rotating using a Blade Buddy and torque to 75 ft-lbs.

7.10 TIRES

Check the tire pressures after every 8 hours of operation or daily.

Caster Wheels	25 PSI
Rear Wheel	25 PSI
Drive Wheels	12 PSI

7.11 HOPPER

The hopper screen should be cleaned after every 8 hours of operation or daily, whichever occurs first. It may be necessary to clean the screen more frequently when cutting wet and/or dirty grass.

1. Remove the hopper screen from the hopper.
2. Wash the screen using a water hose until all the screen holes are clean.
3. Install the cleaned screen in the hopper.

-IMPORTANT-

Do not use the hopper with the screen removed. Grass clippings will discharge from the hopper with the screen removed.

7.12 CUTTER DECK GEARBOX

A. Checking Lubricant Level

⚠ CAUTION:
Cutter deck gearbox can reach high operating temperatures. Allow cutter deck gearbox to cool before servicing.

The fluid level in the cutter deck gearbox should be checked after every 100 hours of operation or bi-weekly, whichever occurs first.

1. Remove the ignition key and engage the parking brake.
2. Lift the foot plate up to gain access to the gearbox.
3. Clean and remove the check plug from the side of the gearbox. See Figure 7-9. Visually check the fluid level in the plug port. The fluid level must be up to the bottom of the plug port. If the fluid level is low, fill gearbox through the check plug port with EP 80-90 gear oil. Install the check plug and tighten securely.

GEARBOX FLUID CHECK PLUG

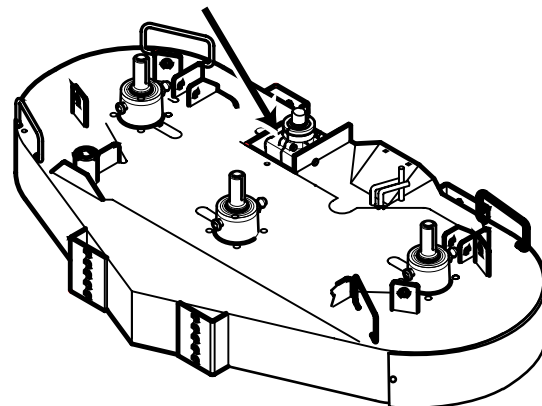

SCR 2002 GFC

Figure 7-9 Gearbox Check Plug

B. Changing Lubricant

The lubricant in the cutter deck gearbox should be changed after every 500 hours of operation or yearly, whichever occurs first.

Section 7

1. Remove the hair pins and raise the cutter deck to the highest cut position (5").
2. Using the caster wheel arm, lift up the cutter deck and secure in place with the lock pin.
3. Beneath the cutter deck is an access hole to gearbox drain plug. See Figure 7-10. Clean the area thoroughly and then place a suitable container under the drain plug.
8. Using the caster wheel arm, lift the cutter deck frame assembly off the cutter deck and secure in place with the lock pin.
9. Clean and remove the check plug from the side of the gearbox and fill the gearbox with SAE 80W90 lubricant until fluid is level with the bottom of the plug port. Install check plug.
10. Lower the cutter deck frame assembly onto the cutter deck and install the washers and hair pins onto the height adjust pins.

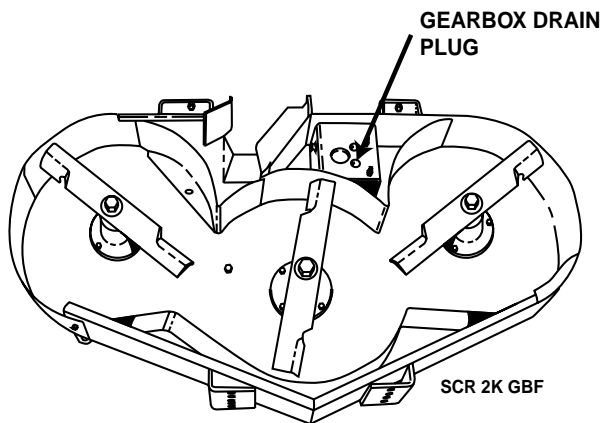

Figure 7-10 Gearbox Drain Plug

4. Remove the drain plug and lower the cutter deck over the container to drain the lubricant.
5. Using the caster wheel arm, lift up the cutter deck and secure in place with the lock pin. Properly discard the drained fluid.
6. Install drain plug and lower the cutter deck.
7. Remove the (4) four hair pins and washers from the deck height adjust pins.

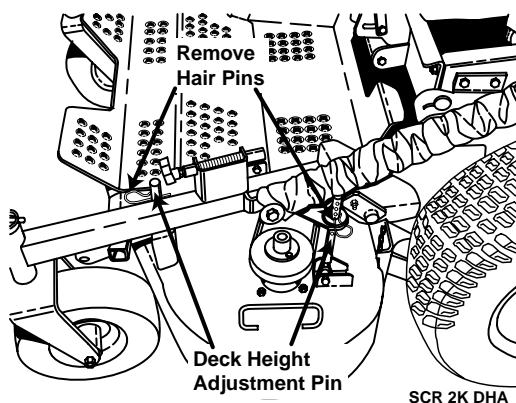

Figure 7-11 Deck Height Pins

7.13 POWER UNIT GEARBOX

A. Checking Lubricant Level

1. Remove the ignition key and engage the parking brake.
2. Lift the seat to gain access to the gearbox dipstick. See Figure 7-12.

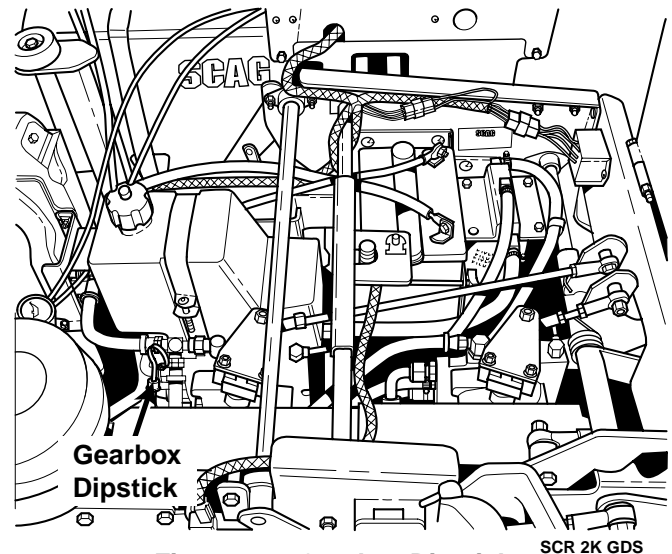

Figure 7-12 Gearbox Dipstick

3. Remove and clean the dipstick. Visually check the fluid level on the dipstick. The fluid level must be between the (2) two marks on the dipstick. See Figure 7-13. If the fluid level is low, fill the gearbox through the dipstick tube with EP 80-90 gear oil. Install the dipstick after proper fluid level has been achieved.



Figure 7-13 Fluid Level

B. Changing Lubricant

The lubricant in the power unit gearbox should be changed after every 500 hours of operation or yearly, whichever occurs first.

1. Beneath the power unit is an access hole to the gearbox drain plug. Clean the area thoroughly and place a suitable container under the drain plug.
2. Remove the drain plug and drain the lubricant into the container and properly discard.
3. Reinstall the drain plug and add EP-80/90 lubricant through the dipstick tube. Approximately 6 ounces of fluid will be needed to fill the gearbox. Follow the procedure in section 7.13 A. Checking Lubricant Level, to fill the gearbox to the proper level.

7.14 BODY, DECK, HOPPER AND UPHOLSTERY

CAUTION:

Do not wash any portion of the equipment while it is hot. Do not wash the engine; use compressed air.

1. After each use, wash the mower, deck and hopper. Use cold water and automotive cleaners. Do not use pressure cleaners.
2. Do not spray electrical components.
3. Use a mild soap solution or a vinyl/rubber cleaner to clean the seat.
4. Repair damaged metal surfaces and use Scag touch-up paint available from your authorized Scag dealer. Wax or polish the mower for maximum paint protection.

NOTES

CUTTER DECKS

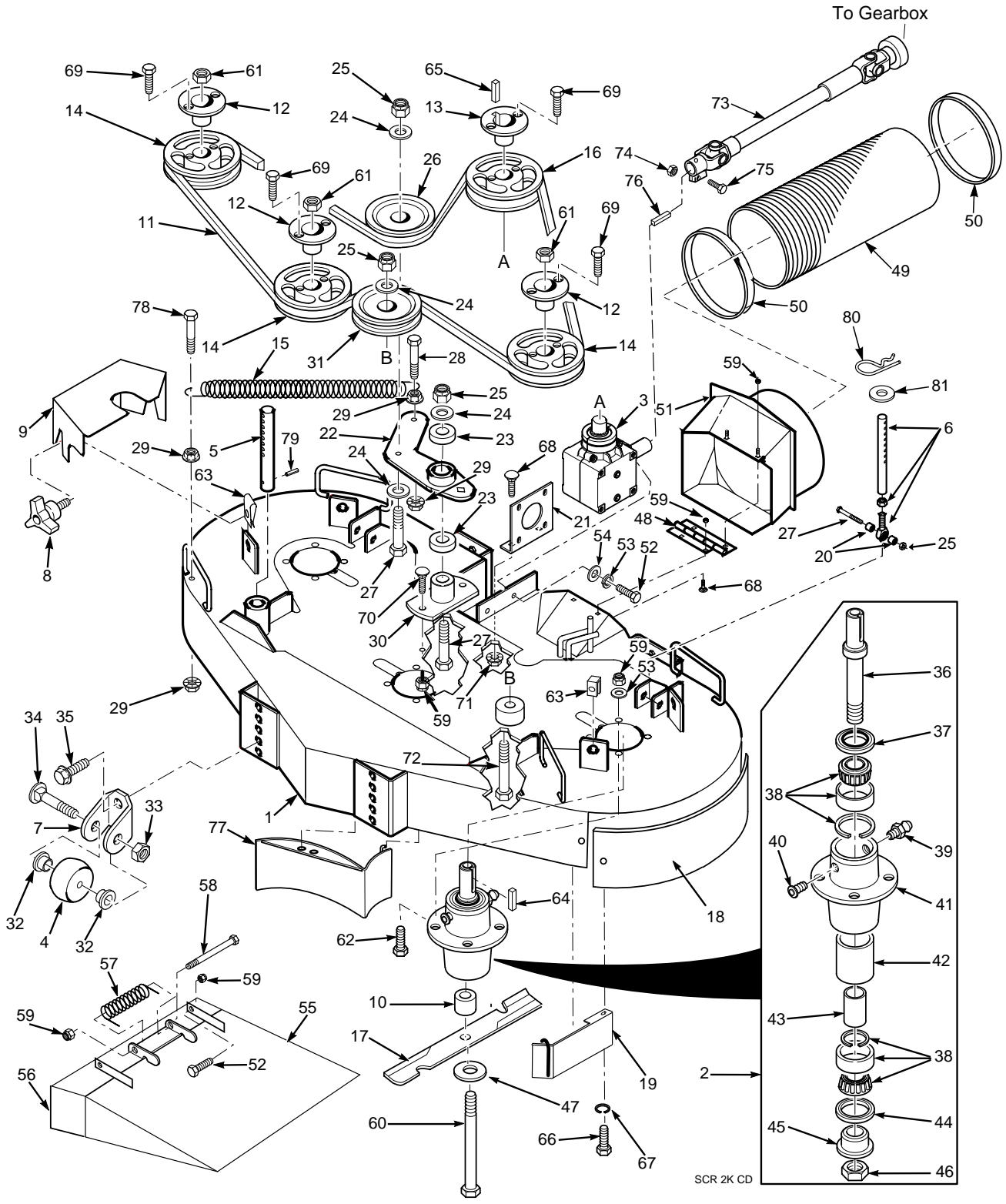



CUTTER DECKS

Ref. No.	Part. Number	Description	42	48	52	Ref. No.	Part. Number	Description	42	48	52
1	461365	Cutter Deck with Decals	x			42	43312	Spacer, Outside	x	x	x
	461330	Cutter Deck with Decals		x		43	43296	Spacer, Inside	x	x	x
	461371	Cutter Deck with Decals			x	44	481025	Seal, Bottom	x	x	x
2	46631	Spindle Assembly	x	x	x	45	43297	Bushing, Spindle Bottom	x	x	x
3	482486	Gearbox, Cutter Deck	x	x	x	46	481035	Nut, Special 1 - 1/16-18	x	x	x
4	481632	Wheel, Anti-Scalp	x	x	x	47	04040-10	Flat Washer 5/8"	x	x	x
5	43515	Pin, Front Deck Height Adjust.	x	x	x	48	482077	Hinge, Rear Chute	x	x	x
6	482075	Pin, Rear Deck Height Adjust.	x	x	x	49	482076	Tube, Discharge 8" ID	x	x	x
7	422478	Bracket, Anti-Scalp Wheel	x	x	x	50	482134	Clamp, Duct 8"	x	x	x
8	481625-01	Knob w/Stud	x	x	x	51	451117	Chute, Rear Discharge	x	x	x
9	423366	LH Belt Cover	x			52	04001-09	Bolt, HH 5/16-18 x 1.0"	x	x	x
	422807	LH Belt Cover		x	x	53	04030-03	Lockwasher, 5/16"	x	x	x
	423367	RH Belt Cover	x			54	04040-15	Washer, Flat 5/16"	x	x	x
	422808	RH Belt Cover		x	x	55	461419	Chute, Side Discharge	x		
10	43590	Spacer, Spindle Bottom	x	x	x	55	461329	Chute, Side Discharge		x	x
11	482336	Belt, Cutter Deck Drive	x			56	461415	Bracket, Side Discharge Chute	x		
	481979	Belt, Cutter Deck Drive		x			461328	Bracket, Side Discharge Chute		x	
	482338	Belt, Cutter Deck Drive			x		461411	Bracket, Side Discharge Chute			x
12	48926	Hub, Tapered 1.125" bore	x	x	x	57	482245	Spring, Discharge Chute	x	x	x
13	48141	Hub, Tapered 1.00" bore	x	x	x	58	04001-108	Bolt, HH 5/16-18 x 4.5"	x	x	x
14	482148	Pulley, 4.75" OD Tapered Bore	x			59	04021-10	Nut, Elastic Stop 5/16-18	x	x	x
	48924	Pulley, 5.75" OD Tapered Bore		x	x	60	04001-158	Bolt, 5/8-11 x 9.5" LH Thread	x	x	x
15	481522	Spring, Belt Tension	x	x	x	61	04020-29	Nut, 5/8-11 LH Thread	x	x	x
16	481435	Pulley, 5.35" OD Tapered Bore	x			62	04001-10	Bolt, HH 5/16-18 x 1.25"	x	x	x
	48753	Pulley, 6.35" OD Tapered Bore		x	x	63	04110-03	U-Nut, 3/8-16	x	x	x
17	482449	Blade, Cutter 14.5" LH	x			64	04063-08	Key, 1/4 x 1/4 x 2.0"	x	x	x
	482450	Blade, Cutter 16.5" LH		x		65	04063-01	Key, 1/4 x 1/4 x 1.25"	x	x	x
	482451	Blade, Cutter 18.0" LH			x	66	04001-19	Bolt, 3/8-16 x 1.0"	x	x	x
18	451398	Skirt, Weldment Bolt On	x			67	04030-04	Lock Washer 3/8" Spring	x	x	x
	451126	Skirt, Weldment Bolt On		x		68	04003-12	Bolt, Carriage 5/16-18 x .75"	x	x	x
	451393	Skirt, Weldment Bolt On			x	69	04001-01	Bolt, HH 1/4-20 x .75"	x	x	x
19	451397	Baffle, Bolt On	x			70	04003-04	Bolt, Carriage 5/16-18 x 1.0"	x	x	x
	451091	Baffle, Bolt On		x	x	71	04019-03	Nut, Serr. Flng. 5/16-18	x	x	x
20	43512	Spacer	x	x	x	72	04001-77	Bolt, HH 3/8-16 x 3.5"	x	x	x
21	422426	Plate, Gearbox Mounting	x	x	x	73	482426	Driveshaft	x	x	x
22	451096	Idler Arm	x	x	x	74	04021-09	Nut, Elastic Stop 3/8-16	x	x	x
23	48224	Bearing, Ball	x	x	x	75	04001-21	Bolt, Hex Head 3/8-16 x 1-3/4"	x	x	x
24	04043-04	Flat Washer 3/8"	x	x	x	76	04063-01	Key, 1/4 x 1/4 x 1-1/4"	x	x	x
25	04021-09	Nut, Elastic Stop 3/8-16	x	x	x	77	423336	Baffle, Rear	x		
26	482416	Pulley, Idler	x	x	x		451092	Baffle, Rear		x	
27	04001-54	Bolt, Hex Head 3/8-16 x 3"	x	x	x		451394	Baffle, Rear			x
28	04001-136	Bolt, Hex Head 3/8-16 x 1.5 GR8	x	x	x	78	04001-135	Bolt, Hex Head 3/8-16 x 1-3/4"Gr.8	x	x	x
29	04019-04	Nut, Serr. Flng. 3/8-16	x	x	x	79	04060-08	Roll Pin	x	x	x
30	422713	Pivot, Idler Arm	x	x	x	80	04062-04	Hair Pin Cotter	x	x	x
31	48269	Pulley, Idler 5.0"	x	x	x	81	04040-10	Flatwasher, 5/8-.688 x 1.750 x .134	x	x	x
32	48100-15	Bushing .376 ID Oilite	x	x	x						
33	04021-05	Lock Nut, 3/8-16 Center Lock	x	x	x						
34	04003-26	Bolt, Carriage 3/8-16 x 4.0"	x	x	x						
35	04017-27	Bolt, Hex Serr. Flng. 3/8-16 x 1.0"	x	x	x						
36	43298	Shaft, Spindle	x	x	x						
37	481024	Seal, Top	x	x	x						
38	481022	Bearing Assenbly	x	x	x						
39	48114-04	Grease Fitting	x	x	x						
40	48677	Relief Fitting, Grease	x	x	x						
41	43294	Housing, Spindle	x	x	x						

-NOTE-

Some of the hardware is common hardware and you may purchase it locally. Be sure that all bolts purchased locally are a grade 5.

CUTTER DECK SUPPORT COMPONENTS

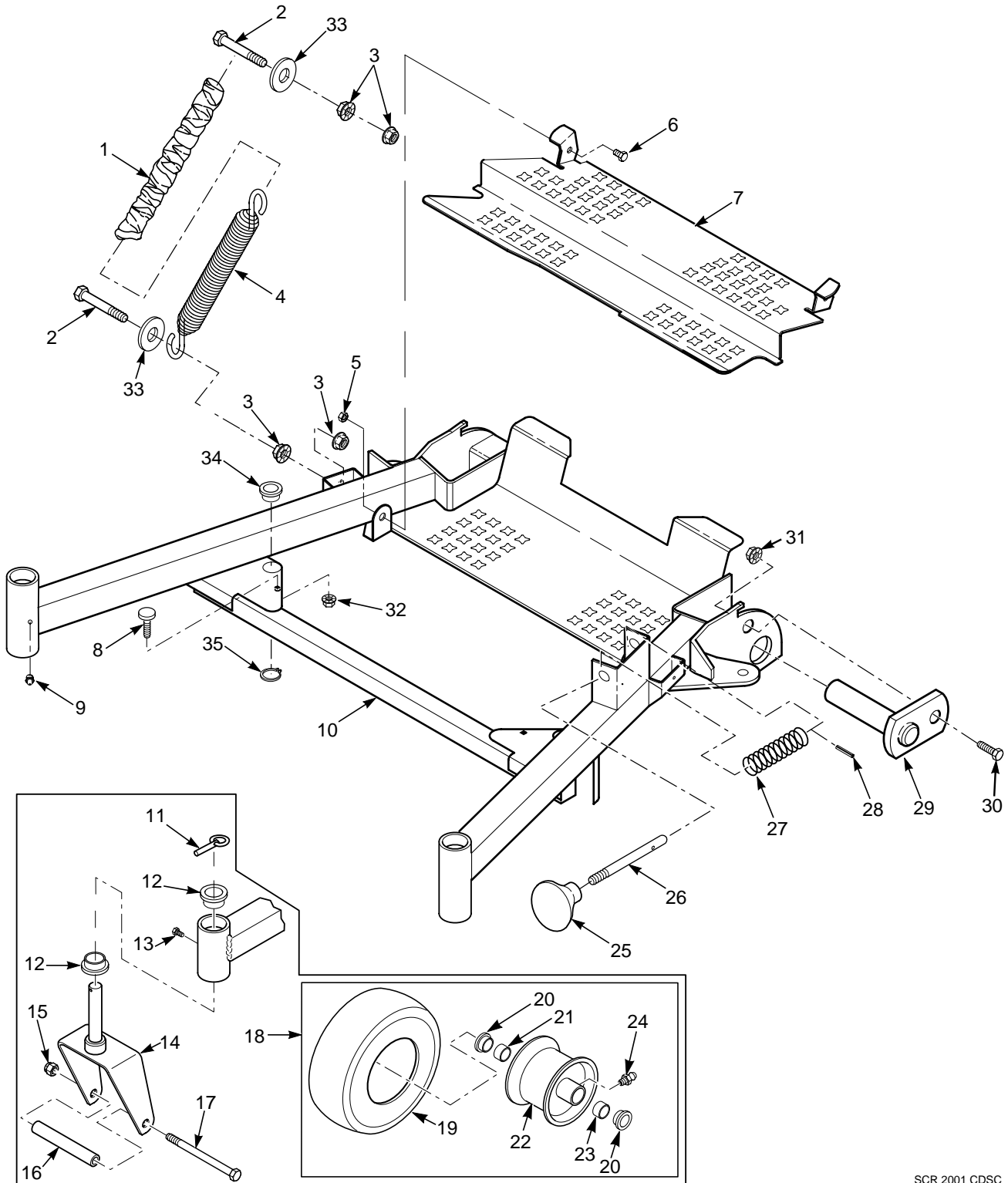

SCR 2001 CDSC

CUTTER DECK SUPPORT COMPONENTS

Ref. No.	Part. Number	Description	42	48	52
1	482078	Cover, Spring	x	x	x
2	04001-52	Bolt, Hex Head 1/2-13 x 2.5"	x	x	x
3	04019-06	Nut, 1/2-13 Serrated Flange	x	x	x
4	481993	Spring, Cutter Deck Lift	x	x	x
5	04021-09	Nut, 3/8-16 Elastic Stop	x	x	x
6	04001-19	Bolt, Hex Head 3/8-16 x 1"	x	x	x
7	423234	Footplate	x		
	422775	Footplate		x	x
8	481284	Bumper, Rubber	x	x	x
9	48114-04	Fitting, Grease	x	x	x
10	451386	Frame, Cutter Deck Mounting	x		
	451196	Frame, Cutter Deck Mounting		x	
	451381	Frame, Cutter Deck Mounting			x
11	04066-01	Pin, Quick	x	x	x
12	48100-17	Bushing, 1" ID Oilite	x	x	x
13	482028-01	Plug, 1/4-28	x	x	x
14	45325	Yoke, Caster	x	x	x
15	04021-07	Nut, 1/2-13 Elastic Stop	x	x	x
16	43511	Spacer	x	x	x
17	04001-80	Bolt, Hex Head 1/2-13 x 6.5"	x	x	x
18	481843	Wheel, Caster 11 x 4.0-5 (Incl. items #19 through #24)	x	x	x
19	482192	Tire, 11 x 4.0-5	x	x	x
20	481770	Retainer	x	x	x
21	481769	Roller Bearing .625 x 3.25"	x	x	x
22	481844	Rim, 5.0 x 3.25"	x	x	x
23	481846	Roller Bearing .625 x 1.0"	x	x	x
24	48114-05	Fitting, Grease	x	x	x
25	481245	Knob, Cutter Deck Release	x	x	x
26	43543	Rod, Threaded	x	x	x
27	481992	Spring	x	x	x
28	04060-08	Pin, Roll 3/16 x 1.5"	x	x	x
29	451199	Pin, Deck Frame Pivot	x	x	x
30	04003-04	Bolt, Carriage 5/16-18 x 1"	x	x	x
31	04021-10	Nut, 5/16-18 Elastic Stop	x	x	x
32	04019-03	Nut, 5/16-18 Serrated Flange	x	x	x
33	04040-10	Flatwasher, 5/8-.688 x 1.750 x .134	x	x	x
34	43530	Bushing	x	x	x
35	04050-16	Snap-Ring	x	x	x

-NOTE-

Some of the hardware is common hardware and you may purchase it locally. Be sure that all bolts purchased locally are a grade 5.

SHEET METAL

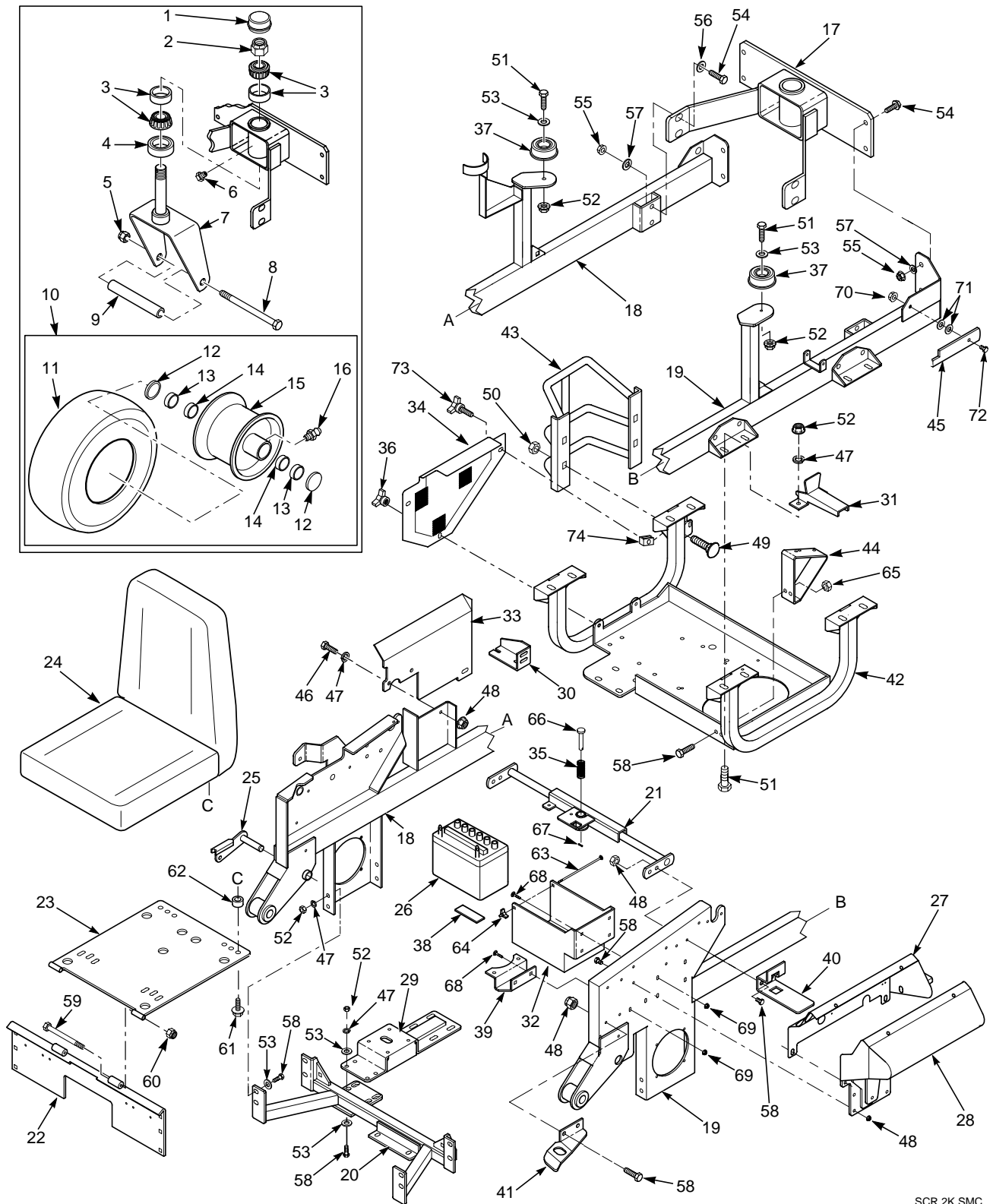

SCR 2K SMC

SHEET METAL

Ref. No.	Part. Number	Description	Ref. No.	Part. Number	Description
1	481559	Cap, Grease	58	04001-32	Bolt, Hex Head 3/8-16 x 1.25"
2	04021-20	Nut, Elastic Jam 1.0-14	59	04001-63	Bolt, Hex Head 5/16-18 x 3.5"
3	481657	Bearing, 1.0 Diameter	60	04021-10	Nut, Elastic Stop 5/16"
4	481025	Seal, 2.00 OD x 1.625 ID	61	04017-16	Bolt, Capscrew 5/16-18 x .75"
5	04021-13	Nut, Elastic Stop 5/8-11	62	43512	Spacer
6	482028-01	Plug, 1/4-28	63	04003-01	Bolt, Carriage 1/4-20 x 6"
7	451187	Yoke, Wheel	64	04029-01	Wing Nut, 1/4-20 x .75"
8	04001-41	Bolt, Hex Head 5/8-11 x 9.5"	65	04021-09	Nut, Elastic Stop 3/8-16
9	43021	Spacer	66	43462	Pin
10	482043	Wheel Assy, 16 x 6.5-8 (Inc. # 11 thru # 16)	67	04060-01	Roll Pin, Spring 5/32 x .75"
11	482192	Tire, 16 x 6.5-8	68	04003-12	Bolt, Carriage 5/16-18 x .75"
12	481897	Seal, Wheel Bearing	69	04019-03	Nut, Serrated Flange 5/16-18
13	481896	Cone, Bearing	70	04021-10	Nut, Elastic Stop 5/16-18
14	481897	Cup, Bearing	71	04032-01	Washer
15	481894	Rim Assy, (Includes Item # 12, 13, 14, & 16)	72	04001-09	Bolt, Hex Head 5/16-18 x 1"
16	48114-06	Fitting, Grease	73	481625-01	Knob, w/stud 3/8-16 x 1-1/4"
17	451186	Weldment, Rear Caster Support	74	04110-03	U-Nut, 3/8-16
18	461319	Weldment, Main Frame RH			
19	451171	Weldment, Main Frame LH			
20	451173	Weldment, Axle Support			
21	451174	Weldment, Seat Support			
22	451177	Plate, Front Crossmember			
23	451178	Weldment, Seat Plate			
24	482220	Seat Assy.			
25	451179	Weldment, Deck Stop			
26	48015	Battery, purchase locally			
27	461473	Cover, Instrument Panel			
28	422855	Rear, Instrument Panel			
29	451415	Weldment, Gearbox Support			
30	422976	Plate, Gearbox Upper			
31	423311	Mount, Fuel Tank Rear			
32	422936	Box, Battery			
33	423031	Heatshield			
34	423233	Cover, PTO Clutch			
35	482204	Spring, Seat			
36	04029-03	Knob			
37	482074	Pad, Rubber Hopper Rest			
38	48657	Pad, Rubber			
39	422935	Bracket, Hydraulic Filter Mounting			
40	423252	Bracket, Fuel Tank Front			
41	422934	Catch, Cutter Deck			
42	451288	Weldment, Engine Deck			
43	451256	Weldment, Muffler Guard			
44	423005	Bracket, Oil Cooler			
45	422988	Rod, Hopper Prop			
46	04001-19	Bolt, Hex Head 3/8-16 x 1"			
47	04030-04	Lockwasher 3/8"			
48	04019-04	Nut, Serrated Flange 3/8-16			
49	04003-33	Bolt, Carriage 7/16-14 x 1"			
50	04019-05	Nut, Serrated Flange 7/16-14			
51	04001-20	Bolt, Hex Head 3/8-16 x 1.5"			
52	04021-09	Nut, Elastic Stop 3/8-16			
53	04041-07	Flatwasher, 3/8"			
54	04001-07	Bolt, Hex Head 1/2-13 x 1.5"			
55	04021-07	Nut, Elastic Stop 1/2-13			
56	04040-07	Flatwasher 1/2"			
57	04030-06	Lockwasher 1/2"			

-NOTE-

Some of the hardware is common hardware and you may purchase it locally. Be sure that all bolts purchased locally are a grade 5.

BLOWER ASSEMBLY

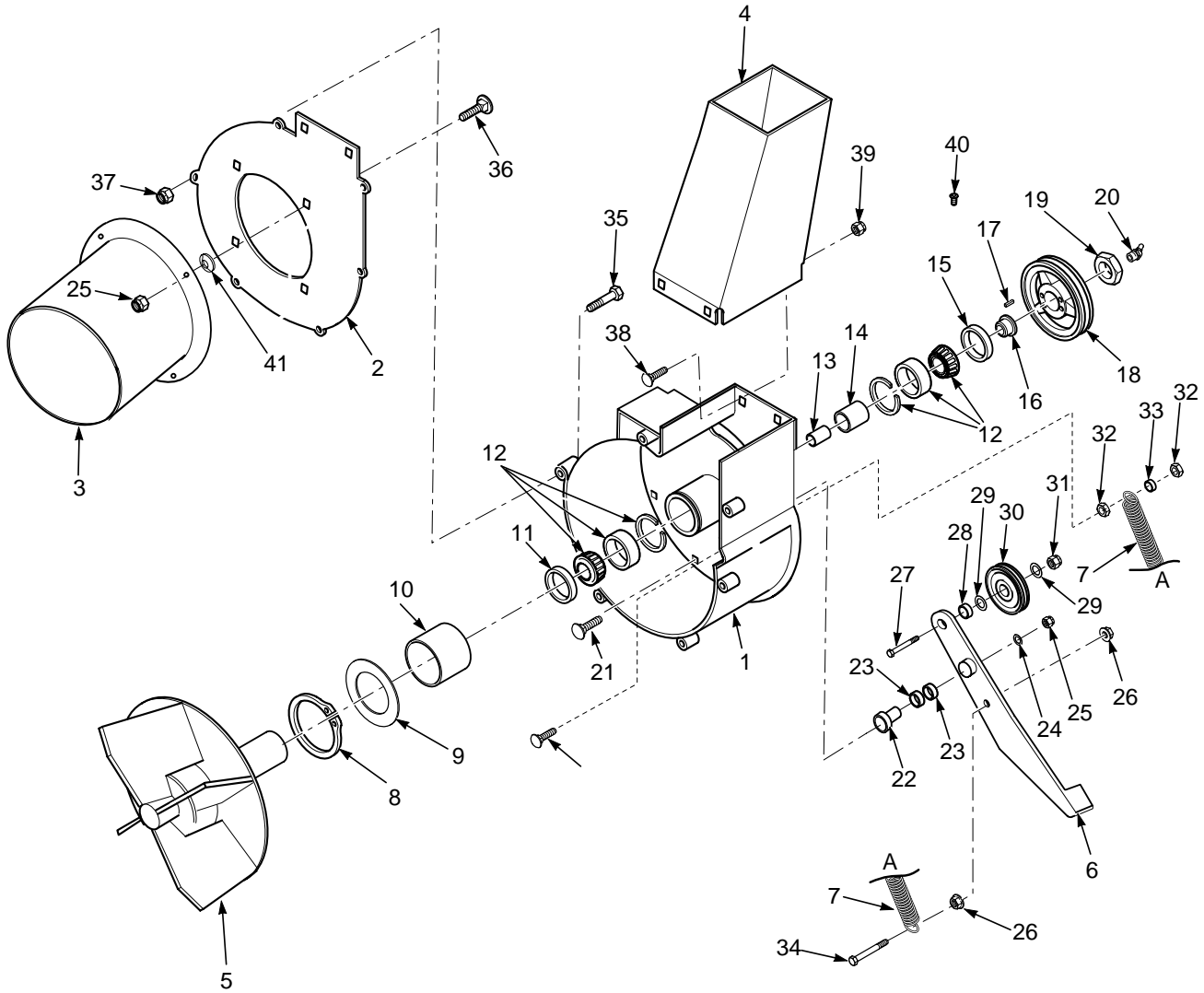

BLOWER ASSEMBLY

Ref. Part. No. Number Description	Ref. Part. No. Number Description
1 451202 Blower Housing, Rear	36 04003-23 Bolt, Carriage 3/8-16 x 1.0
2 422812 Blower Housing, Front	37 04021-10 Nut, Elastic Stop 5/16-18
3 451116 Inlet	38 04003-06 Bolt, Carriage 1/4-20 x 1.0
4 461321 Outlet	39 04021-08 Nut, Elastic Stop 1/4-20
5 451201 Fan	40 48677 Relief Fitting
6 461326 Idler Arm, Weldment (includes #22)	41 04024-02 Push Nut, 3/8 Thread
7 481995 Spring	
8 04050-15 Ring, Retaining 2.5 ext.	
9 421665 Washer, Retainer	
10 48100-12 Bushing, Oilite 2.505 ID	
11 481024 Seal, 2.00 OD x 1.50 Bore	
12 481022 Bearing Assembly	
13 43296 Spacer, Inside	
14 43312 Spacer, Outside	
15 481025 Seal, 2.00 OD x 1.625 Bore	
16 43297 Bushing	
17 04063-21 Key, 1/4 x .874 Woodruff	
18 481468 Pulley, 5.25 OD	
19 481106 Nut, 1-1/16 - 18 LH Thread	
20 48114-09 Grease Fitting, 65 degree angle	
21 04003-21 Bolt, Carriage 3/8-16 x 2.5"	
22 461326 Idler Arm w/pivot	
23 48224 Bearing	
24 04043-04 Flatwasher 3/8"	
25 04021-09 Nut, Elastic Stop 3/8-16	
26 04019-04 Nut, Serr. Flng. 3/8-16	
27 04001-46 Bolt, HH 3/8-16 x 2.25"	
28 43282 Spacer	
29 04043-04 Flat Washer 3/8"	
30 482079 Pulley, 3.0" diameter	
31 04021-09 Nut, Elastic Stop 3/8-16	
32 04019-04 Nut, Serr. Flng. 3/8-16	
33 43212 Spacer	
34 04001-136 Bolt, HH 3/8-16 x 1.5"	
35 04001-11 Bolt, HH 5/16-18 x 1.5"	

-NOTE-

Some of the hardware is common hardware and you may purchase it locally. Be sure that all bolts purchased locally are a grade 5.

ENGINE AND ATTACHING PARTS

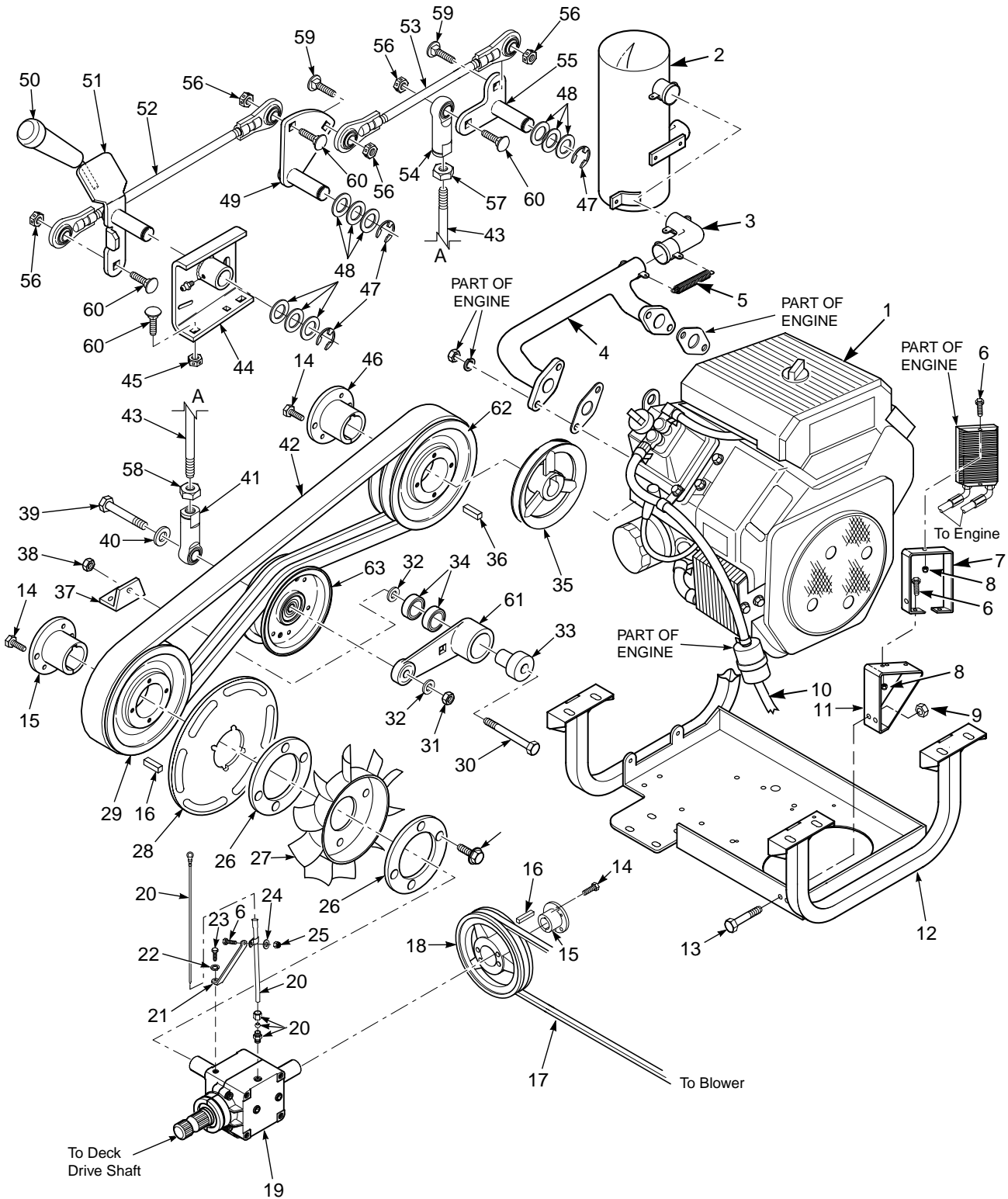

ENGINE AND ATTACHING PARTS

Ref. Part. No. Number Description	Ref. Part. No. Number Description
1 481967 Engine, 25 HP Kohler (Spec.PS-68650)	32 04030-04 Lock Washer, 3/8"
482271 Engine, 27 HP Kaw.(Spec. FD750D-AS04)	33 43503 Pivot, Idler
2 481946 Muffler	34 48224 Bearing, Idler Arm
3 482081 Pipe, Exhaust	35 481788 Pulley, 5.45" OD - 1.125 Bore
4 481947 Manifold, Exhaust, Kohler	36 04063-20 Key, 1/4 x1/4 x 1"
481944 Manifold, Exhaust, Kawasaki	04063-23 Key, 1/4 x 1/4 x 3-1/4"
5 482329 Spring, Exhaust	37 423014 Mounting Bracket, Idler
6 04001-01 Bolt, Hex Head 1/4-20 x .75"	38 04021-09 Nut, Elastic Stop 3/8"
7 423006 Guard, Oil Cooler, Kohler Only	39 04001-30 Bolt, Hex Head 3/8-16 x 4"
8 04019-02 Nut, Serrated Flange 1/4-20	40 04030-04 Lock Washer, 3/8"
9 04021-09 Nut, Elastic Stop 3/8-16	41 482331 Rod End, 3/8-24 LH Female
10 48058 Hose, Fuel 1/4" ID (order by the inch)	42 482263 Belt
11 423005 Bracket, Oil Cooler, Kohler Only	43 482231 Link, PTO
12 451401 Weldment, Engine Deck	44 451293 Bracket, PTO
13 04001-20 Bolt, Hex Head 3/8-16 x 1.5"	45 Nut,
14 04001-14 Capscrew, Hex Head 1/4-20 x 1"	46 48926 Hub, Tapered 1.125" Bore
15 48141 Hub, Tapered 1" Bore	47 04050-02 External E-Ring
16 04063-01 Key, 1/4 x 1/4 x 1.25"	48 Flatwasher,
17 481977 Belt, Blower	49 451296 Bellcrank Weldment, Front
18 481435 Pulley, 5.35" OD	50 482250 Grip, PTO Lever
19 482500 Gearbox, T-Drive	51 461334 Lever Weldment, PTO Engagement
20 482223 Dipstick Assembly	52 482233 Linkage Assembly, PTO Upper
21 423236 Bracket, Dipstick Tube	53 482232 Linkage Assembly, PTO Center
22 04030-03 Lock Washer, 5/16"	54 482330 Rod End, 3/8-24 RH Female
23 04001-08 Bolt, Hex Head 5/16-18 x 3/4"	55 451297 Bellcrank Weldment, Rear
24 04040-14 Flatwasher, 1/4-.312 x .750 x .065	56 Nut, Center Lock
25 04021-08 Nut, Elastic Stop 1/4-20	57 04020-14 Nut, 3/8-24 LH Thread
26 423115 Spacer, Fan	58 04020-17 Nut, 3/8-24 RH Thread
27 482133 Fan, Cooling	59 Bolt, Carraige
28 423078 Disk, Fan Support	60 Bolt, Carraige
29 482067 Pulley, 4.95" OD Tapered Bore	61 461015 Idler Arm
30 04001-31 Bolt, Hex Head 3/8-16 x 2.5"	62 482067 Pulley, 4.95" OD Tapered Bore
31 04021-09 Nut, Elastic Stop 3/8-16	63 482249 Pulley, Idler 4" Dia.

-NOTE-

Some of the hardware is common hardware and you may purchase it locally. Be sure that all bolts purchased locally are a grade 5.

TRACTION DRIVE COMPONENTS

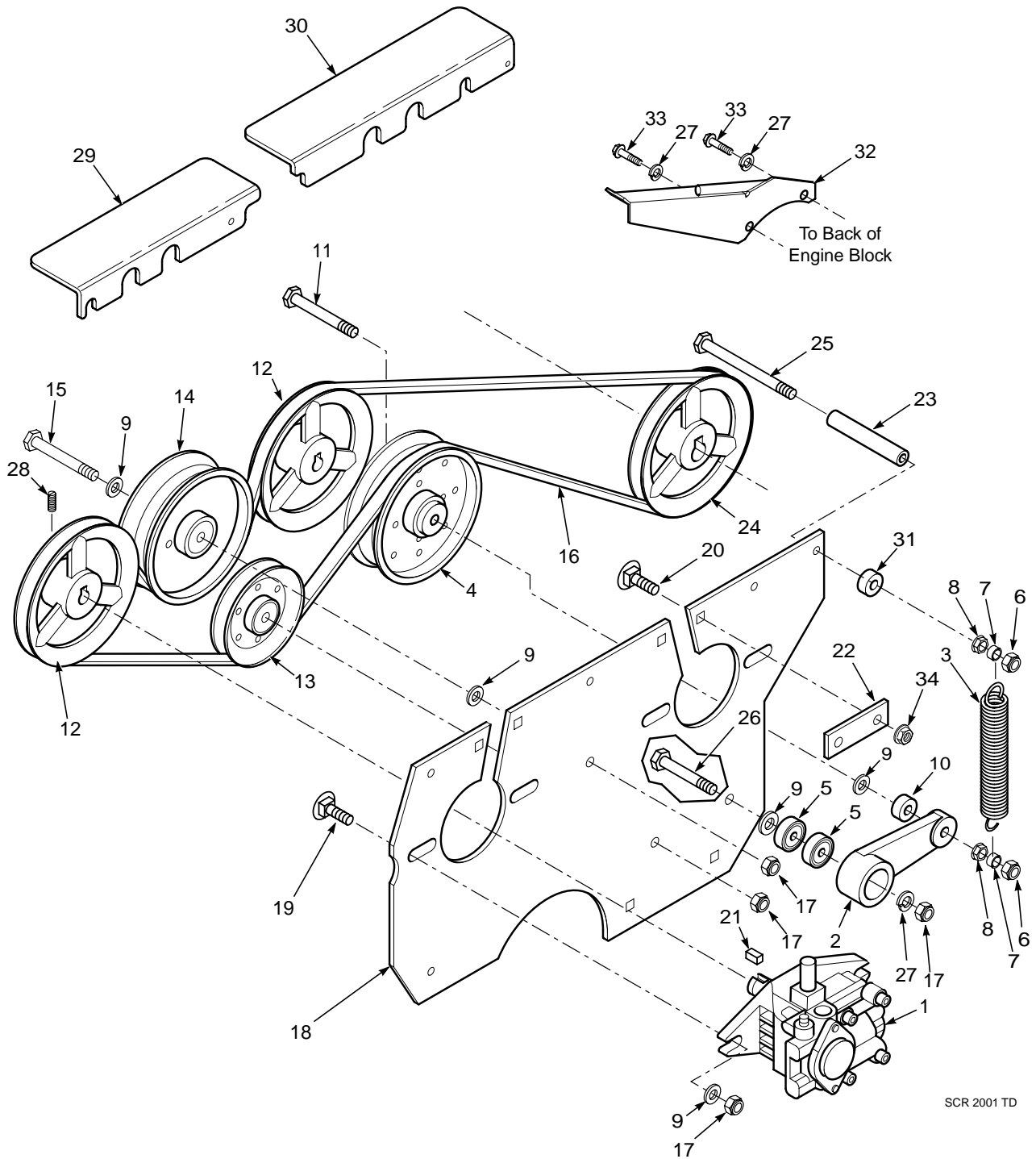

SCR 2001 TD

TRACTION DRIVE COMPONENTS

Ref. No.	Part No.	Description
1	48551	Pump, Hydraulic
2	461015	Idler, Arm
3	481994	Spring, Idler
4	482135	Pulley, Idler
5	48224	Bearing, Idler Arm
6	04021-05	Nut, 3/8-16 Center Lock
7	43212	Spacer
8	04019-04	Nut, 3/8-16 Serrated Flange
9	04043-04	Washer, Flat 3/8"
10	43077	Spacer
11	04001-160	Bolt, 3/8-16 x 3.0"
12	48586	Pulley, 5.45" OD
13	482062	Pulley, 4" OD
14	48413	Pulley, 4" OD
15	04001-31	Bolt, Hex Head 3/8-16 x 2.5"
16	481978	Belt, Pump Drive
17	04021-09	Nut, Elastic Stop 3/8-16
18	422927	Plate, Pump Mounting
19	04003-05	Bolt, Carriage 3/8-16 x 1.5"
20	04003-12	Bolt, Carriage 5/16-18 x .75"
21	04063-14	Key, 5mm x 5mm x 25mm
22	422928	Plate, Keeper
23	43542	Spacer
24	481788	Pulley, 5.45" OD
25	04001-100	Bolt, 3/8-16 x 6"
26	04001-31	Bolt, Hex Head 3/8-16 x 2.5"
27	04030-04	Washer, Lock 3/8"
28	04012-04	Setscrew, .312-18 Thread
29	461317	Cover, Belt Front
30	461318	Cover, Belt Rear
31	43277	Spacer
32	451205	Heatshield
33	04001-19	Bolt, Carriage 3/8-16 x 1"
34	04019-03	Nut, Serr. Flange 5/16-18

-NOTE-

Some of the hardware is common hardware and you may purchase it locally. Be sure that all bolts purchased locally are a grade 5.

HYDRAULIC PUMP

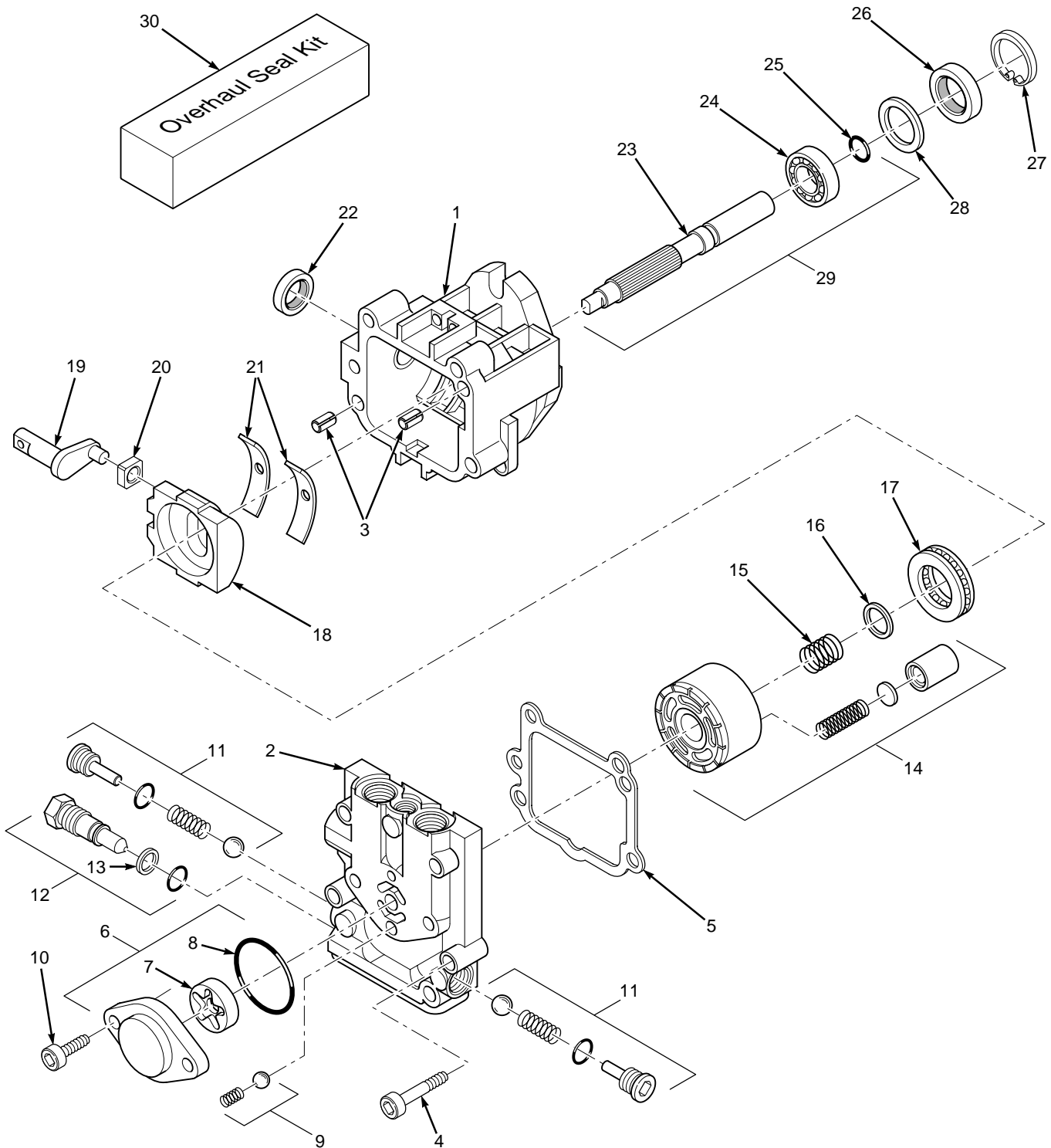

HYDRAULIC PUMP

Ref. No.	Part No.	Description
1	HG 2513017	Housing Kit (Includes Housing, Journal Bearing)
2	HG 2513016	End Cap
3	HG 9004800-2506	Straight Headless Pin
4	HG 9007314-0810	Socket Head Screw 5/16-18x1.0
5	HG 2003067	End Cap Gasket
6	HG 2513027	Charge Pump Kit (Includes Charge Cover, Gerotor Assy., O-Ring)
7	HG 50273	Gerotor Assembly
8	HG 9004101-1340	O-Ring
9	HG 2510064	Charge Relief Valve Kit
10	HG 50095	Socket Head Screw
11	HG 2510027	Check Valve Kit (Includes Check Plug, Spring, O-Ring, Orifice Check Valve)
12	HG 2513030	Bypass Valve Kit (Includes Bypass Valve, O-Ring, Back-up Ring)
13	HG 9006110-0120	Backup Ring
14	HG 70079	Cylinder Block Kit
15	HG 2003014	Block Spring
16	HG 2003017	Block Thrust Washer
17	HG 2003044	Roller Thrust Bearing
18	HG 2003087	Swash Plate
19	HG 2003005	Trunnion Arm
20	HG 2000015	Guide Slot
21	HG 2003023	Cradle Bearing
22	HG 9008000-0126	Lip Seal
23	HG 2003020	Pump Shaft
24	HG 2003043	Ball Bearing
25	HG 2003016	Retaining Ring
26	HG 9008000-0128	Lip Seal
27	HG 2003052	Retaining Ring
28	HG 2003018	Spacer
29	HG 2513038	Shaft Kit (Includes Pump Shaft, Ball Bearing, Retaining Ring)
30	HG 2513018	Overhaul Seal Kit (Includes Gasket, Trunnion Seal, Input Shaft Seal, Charge Pump O-Ring)

-NOTE-

Some of the hardware is common hardware and you may purchase it locally. Be sure that all bolts purchased locally are a grade 5.

CUTTER DECK DRIVE GEARBOX

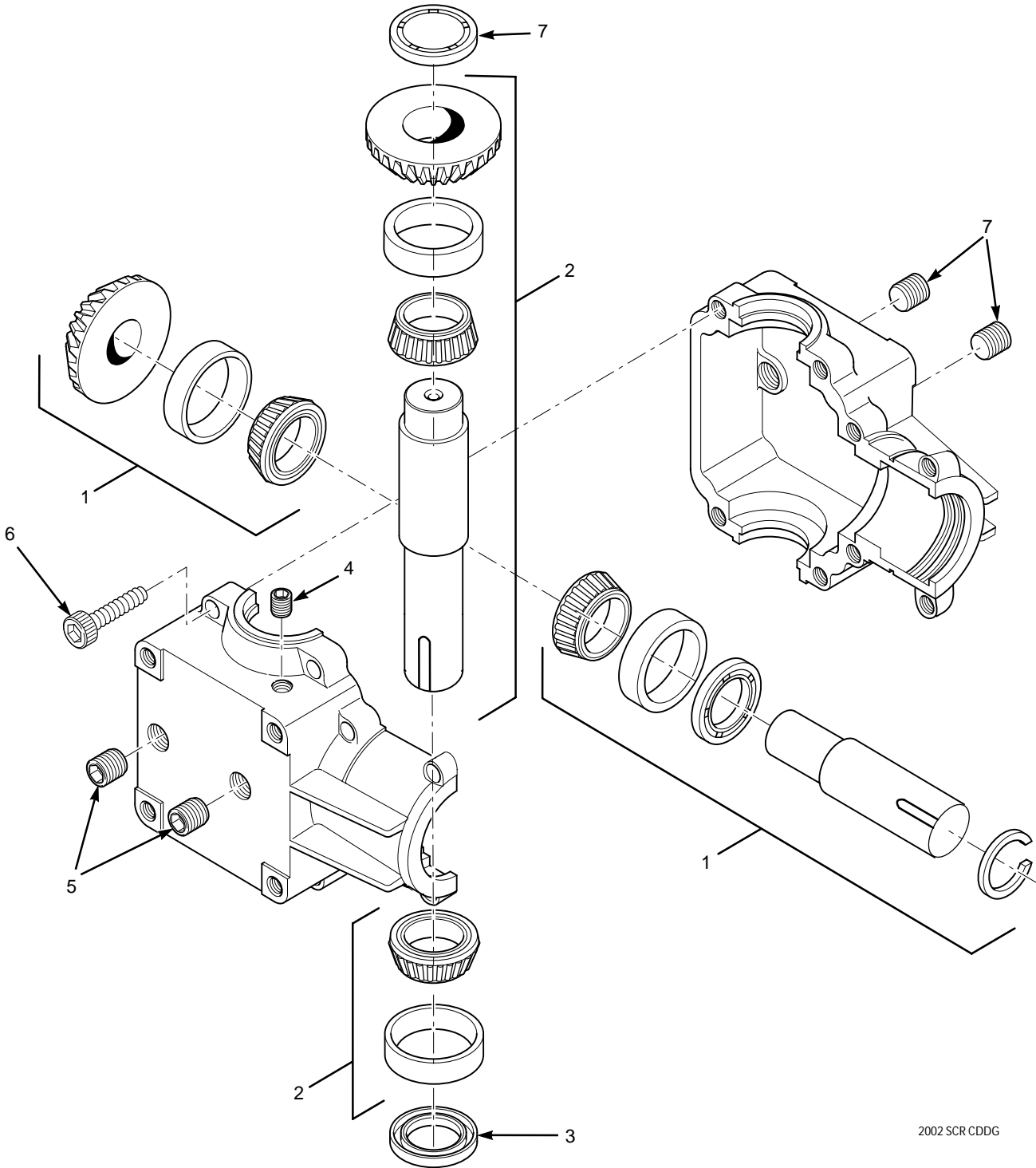

2002 SCR CDDG

CUTTER DECK DRIVE GEARBOX

Ref. No.	Part No.	Description
1	482122	Shaft Assembly
2	482123	Shaft Assembly
3	481651	Seal, 1.00" x 1.50" x 3/16"
4	481652-01	Plug, 1/8" NPT Socket Head
5	481652-02	Plug, 1/4" NPT Socket Head
6	04015-16	Bolt, 5/16-18 x 1.25"
7	482225	End Cap

SPEED AND STEERING CONTROLS

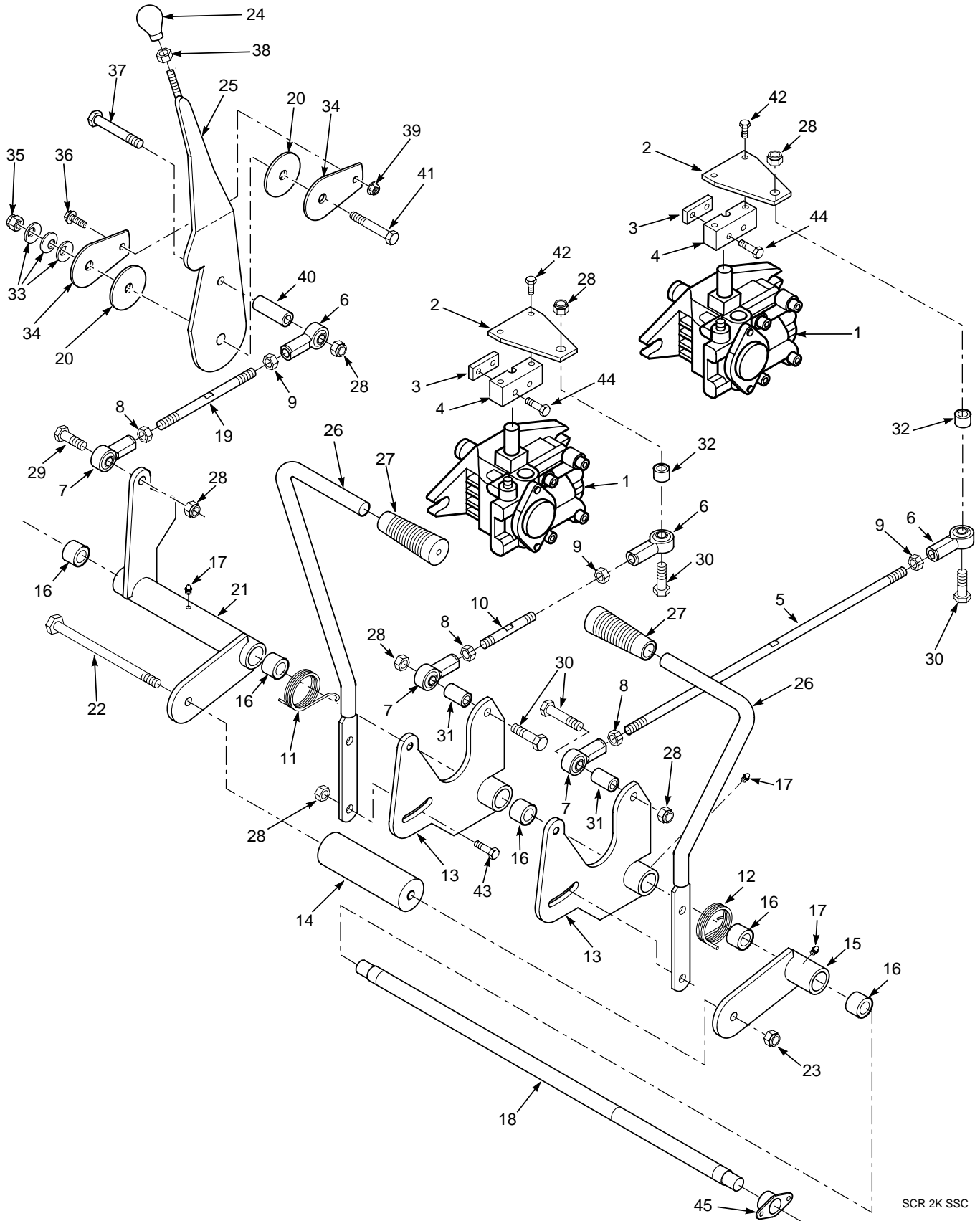

SCR 2K SSC

SPEED AND STEERING CONTROLS

Ref. No.	Part No.	Description
1	48551	Pump, Hydraulic
2	422969	Lever, Pump
3	421203	Clamp, Pump Control
4	48829	Block, Pump Control
5	482177	Rod, Threaded 3/8-24 x 14.675"
6	48464	Rod End, 3/8-24 RH Thread Female
7	48544	Rod End, 3/8-24 LH Thread Female
8	04020-26	Nut, Jam 3/8-24 LH Thread
9	04020-25	Nut, Jam 3/8-24 RH Thread
10	482178	Rod, Threaded 3/8-24 x 2.925"
11	482060	Spring, Torsion RH
12	482059	Spring, Torsion LH
13	451183	Weldment, Steering Control
14	43541	Spacer, Lever Stop
15	451181	Weldment, Speed Control LH
16	48100-06	Bushing, .753 ID Sint.
17	48114-04	Fitting, Grease 1/4-28
18	43544	Shaft, Steering Lever
19	482176	Rod, Threaded 3/8-24 x 3.75"
20	481243	Disc, Friction
21	451182	Weldment, Speed Control RH
22	04001-100	Bolt, Hex Head 3/8-16 x 6"
23	04021-09	Locknut, 3/8-16 Elastic
24	481245	Knob, Speed Control Lever
25	451298	Lever, Speed Control
26	422438	Lever, Steering
27	481477	Grip, Steering Lever
28	04021-09	Nut, Elastic Stop 3/8-16
29	04001-20	Bolt, Hex Head 3/8-16 x 1.5"
30	04001-21	Bolt, Hex Head 3/8-16 x 1.75"
31	43512	Spacer
32	43212	Spacer
33	04032-04	Washer, Belleville 5/8"
34	422198	Plate, Speed Selector
35	04021-13	Nut, Elastic Stop 5/8-11
36	04017-18	Bolt, 5/16-18 x 1.25" Capscrew
37	04001-46	Bolt, Hex Head 3/8-16 x 2.25"
38	04020-12	Nut, 3/8-16 Jam
39	04019-03	Nut, 5/16-18 Serrated Flange
40	43277	Spacer
41	04001-122	Bolt, Hex Head 5/16-18 x 2.25"
42	04001-08	Bolt, Hex Head 5/16-18 x .75"
43	04001-32	Bolt, Hex Head 3/8-16 x 1.25"
44	04001-59	Bolt, Hex Head 1/4-20 x 1.25"
45	48796	Bushing, Self-Aligning

-NOTE-

Some of the hardware is common hardware and you may purchase it locally. Be sure that all bolts purchased locally are a grade 5 unless otherwise noted.

PARKING BRAKE MECHANISM

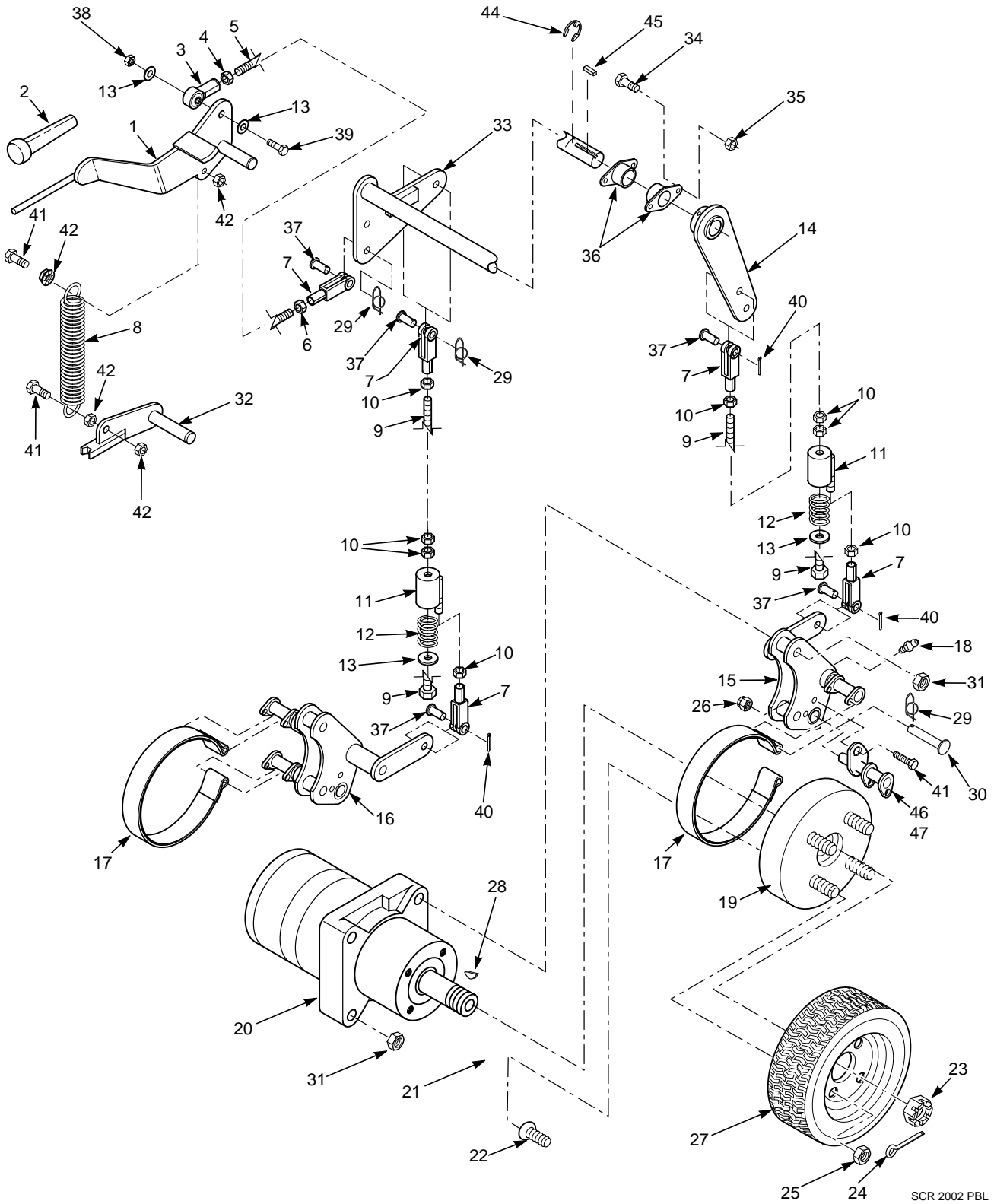

SCR 2002 PBL

PARKING BRAKE MECHANISM

Ref. No.	Part No.	Description
1	461320	Lever, Parking Brake
2	482058	Grip, Parking Brake Lever
3	48544	Rod End, 3/8-24 LH
4	04020-17	Nut, 3/8-24 LH Thread
5	04004-39	Rod, 3/8-24 x 9.5"
6	04020-14	Nut, 3/8-24 RH Thread
7	48343-04	Clevis, 3/8-24
8	481990	Spring
9	04001-162	Bolt, Hex Head 3/8-24 x 8.25"
10	04020-14	Nut, 3/8-24
11	451260	Weldment, Brake Rod
12	48807	Spring
13	04041-07	Flatwasher, 3/8"
14	451224	Weldment, Brake
15	461469	Weldment, Brake Linkage
16	461470	Weldment, Brake Linkage
17	481601	Band, Brake
18	48114-05	Fitting, Grease
19	48589	Drum, Brake
20	481529	Motor, Hydraulic Wheel
21	461438	Hub, Wheel
22	04008-01	Stud, Wheel Mounting 1/2-20
23	48680	Nut, Castle 1.0-20 UNF
24	04061-06	Pin, Cotter 9/16" x 1.5"
25	04028-01	Nut, Lug 1/2-20
26	04021-10	Nut, Elastic Stop 5/16-18
27	482185	Wheel Assy 23 x 8.50-12 (42" Only)
	481833	Tire, 23 x 8.50-12 (42" Only)
	482186	Rim W/Valve Stem (42" Only)
	482044	Wheel Assy 23 x 9.50-12 (48" & 52")
	481659	Rim W/Valve Stem (48" & 52")
	482194	Tire, 23 x 9.50-12 (48" & 52")
28	04063-25	Key, Woodruff 5/16 x 1"
29	04069-01	Pin, Rue Cotter 3/8" Diameter
30	04064-03	Pin, Clevis 3/8" Diameter x 2"
31	04021-19	Locknut, Hex 1/2-13 Center Lock
32	451179	Weldment, Deck Stop
33	451295	Weldment, Brake Shaft
34	04001-08	Bolt, Hex Head 5/16-18 x .75"
35	04021-10	Nut, Elastic Stop 5/16-18
36	482061	Bushing, Self-Aligning
37	04064-02	Pin, Clevis 3/8 x 1.06"
38	04021-09	Nut, Elastic Stop 3/8-16
39	04001-20	Bolt, Hex Head 3/8-16 x 1.5"
40	04061-02	Pin, Cotter 3/32 x .75"
41	04001-09	Bolt, Hex Head 5/16-18 x 1"
42	04019-03	Nut, Serrated Flange 5/16-18
43	04021-04	Nut, Elastic Stop 5/16-18
44	04050-12	E-Clip, .875"
45	04063-20	Key, 1/4 x 1/4 x 1"
46	451073	Brake Linkage Weldment, LH
47	451074	Brake Linkage Weldment, RH

-NOTE-

Some of the hardware is common hardware and you may purchase it locally. Be sure that all bolts purchased locally are a grade 5 unless otherwise noted.

FUEL AND HYDRAULIC COMPONENTS

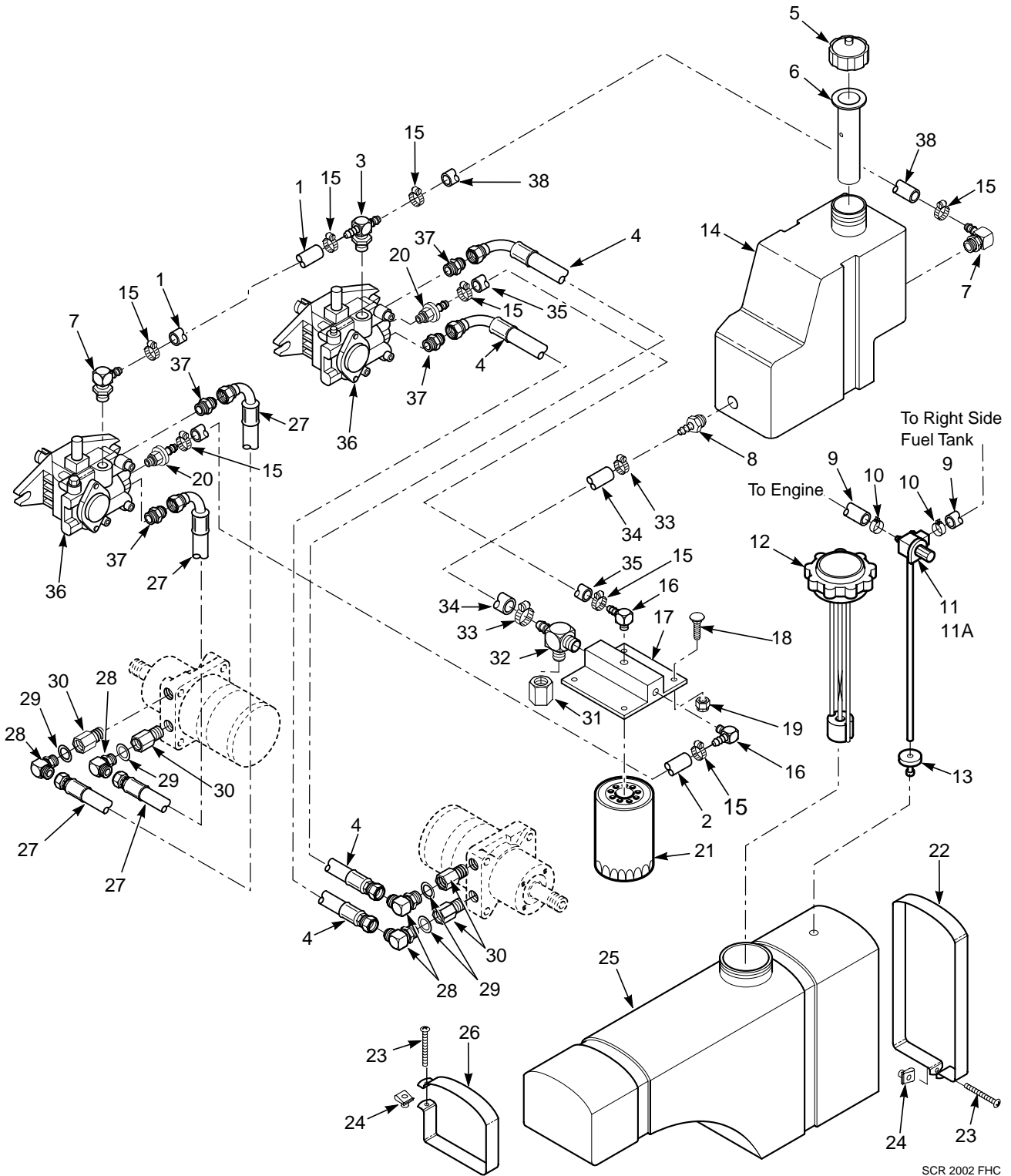

FUEL AND HYDRAULIC COMPONENTS

Ref. Part. No.	Part Number	Description
1	48811	Hose, 3/8 Pushlock 20" Long (order by the inch)
2	48811	Hose, 3/8 Pushlock 30" Long (order by the inch)
3	482277	Tee, Swivel 9/16-18 JIC
4	481960	Hose Assembly, LH
5	481164	Cap, Hydraulic Tank
6	481507	Insert, Filler Neck
7	482266-01	Elbow, 9/16 O-Ring x 3/8 Hose
8	481467-03	Connector, O-Ring to Hose Barb
9	48058	Fuel Hose 1/4" ID
10	48059-01	Clamp, Fuel Hose 1/4" Hose ID
11	481989	Valve, Fuel Shutoff (LH Tank)
11A	482055	Tube, Fuel Standoff (RH Tank)
12	481958	Cap, Fuel Tank w/gauge
13	48309	Bushing, Tank
14	461437	Hydraulic Tank
15	48136-07	Clamp
16	482266-01	Elbow, 9/16 O-Ring x 3/8 Hose
17	482417	Filter Head
18	04001-09	Bolt, Hex Head 5/16-18 x 1"
19	04021-10	Nut, Elastic Stop 5/16-18
20	481467-01	Connector, 7/16 O-Ring x Hose Barb
21	48758	Filter, Hydraulic
22	422939	Strap, Fuel Tank Rear
23	04010-10	Screw, 1/4-20 x 2"
24	04110-01	U-Nut, 1/4-20
25	481957	Fuel Tank
26	422940	Strap, Fuel Tank Front
27	481961	Hose Assembly, RH
28	48350-02	Elbow, 90 Degree 1/2 x 1/2
29	48603-02	O-Ring
30	48938-02	O-Ring Bushing, 5/8 Tube
31	48571-02	Cap, 3/4-16 JIC
32	482481	Fitting, Tee Special
33	48136-05	Clamp
34	482499	Hose, Return Line
35	48811	Hose, 3/8 Pushlock 36" Long (order by the inch)
36	48551	Pump, BDP 10L
37	48572-04	Tube, Union 1/2 x 1/2
38	48811	Hose, 3/8 Pushlock 5" Long (order by the inch)

-NOTE-

Some of the hardware is common hardware and you may purchase it locally. Be sure that all bolts purchased locally are a grade 5.

KOHLER ELECTRICAL SYSTEM

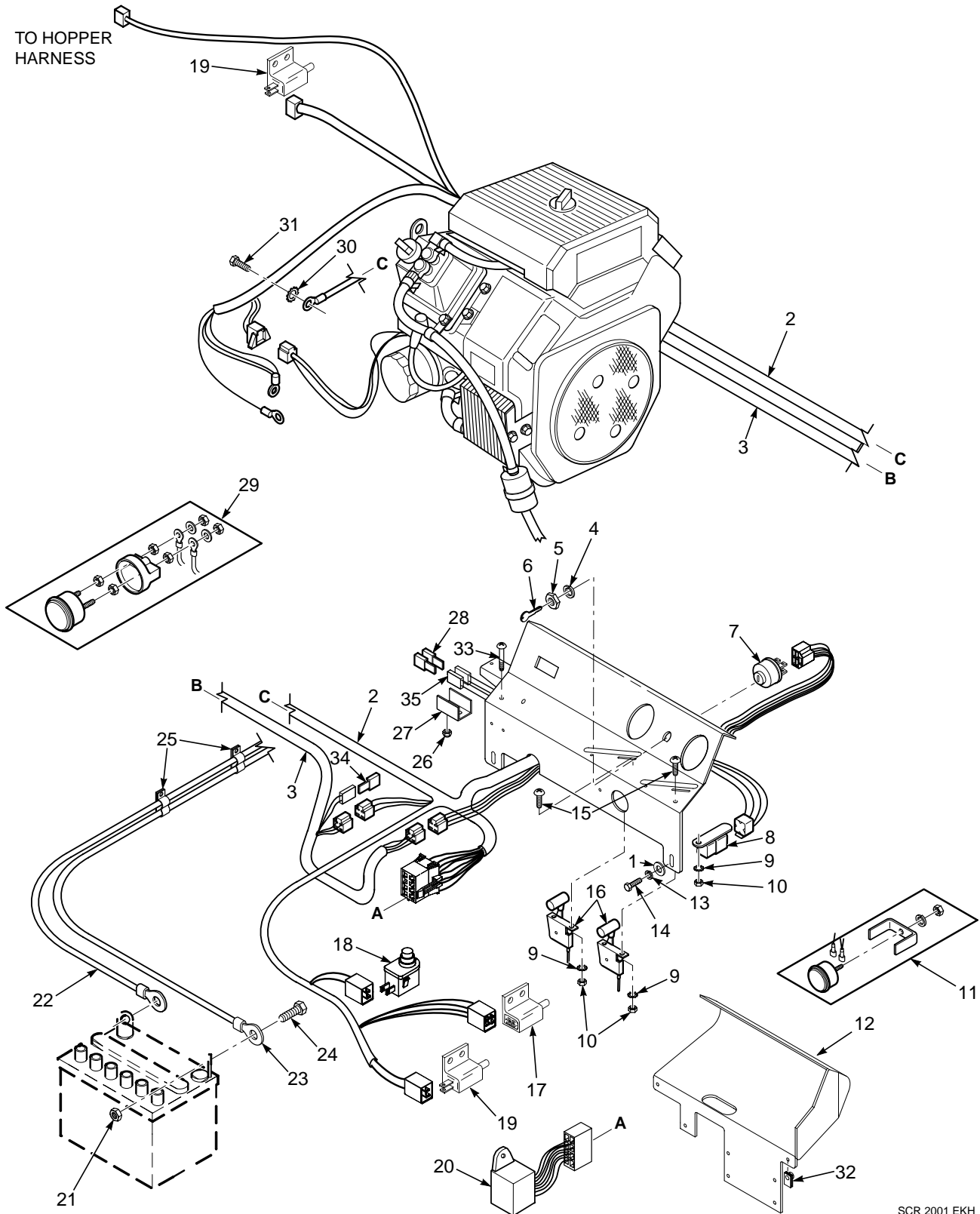

SCR 2001 EKH

KOHLER ELECTRICAL SYSTEM

Ref. Part. No. Number Description	Ref. Part. No. Number Description
1 04040-15 Flatwasher, 5/16-.375 x .875 x .083	21 04020-02 Nut, 1/4-20
2 482318 Wire Harness, SCR	22 48029-19 Battery Cable, Black
3 482319 Wire Harness, Hopper	23 48029-20 Battery Cable, Red
4 48017-03 Lockwasher, Internal 5/8"	24 04001-44 Bolt, Hex Head 1/4-20 x 1/2"
5 48017-04 Nut, 5/8-32 Special	25 48030-18 Cable Clamp, Double
6 48017-02 Key & Ring (includes 2 keys)	26 04021-01 Nut, Elastic Stop #10
7 48798 Keyswitch w/hardware	27 42413 Bracket, Fuse Holder
8 48788 Relay	28 48298 Fuse, 20 Amp
9 04031-01 Lockwasher, #10 external tooth	29 481755 Ammeter
10 04020-01 Nut, #10-32 UNF	30 04030-04 Lockwasher, 3/8"
11 48023 Hour Meter	31 04001-18 Bolt, Hex Head
12 451185 Instrument Panel, Lower	32 04110-02 U-Nut, 5/16-18
13 04030-03 Lockwasher, 5/16	33 04010-11 Screw, #10-32 x 1-1/2"
14 04001-09 Bolt, Hex Head 5/16-18 x 1"	34 482157 Fuse, 15 Amp
15 04010-01 Screw, #10-32 x 1/2"	35 48430 Fuse Holder W/Fuse & Connector
16 482032 Control Cable	
17 481545 Switch, PTO	
18 481638 Switch, Seat	
19 481637 Switch, Brake & Hopper	
20 482313 Interlock Module	

-NOTE-

Some of the hardware is common hardware and you may purchase it locally. Be sure that all bolts purchased locally are a grade 5.

KAWASAKI ELECTRICAL SYSTEM

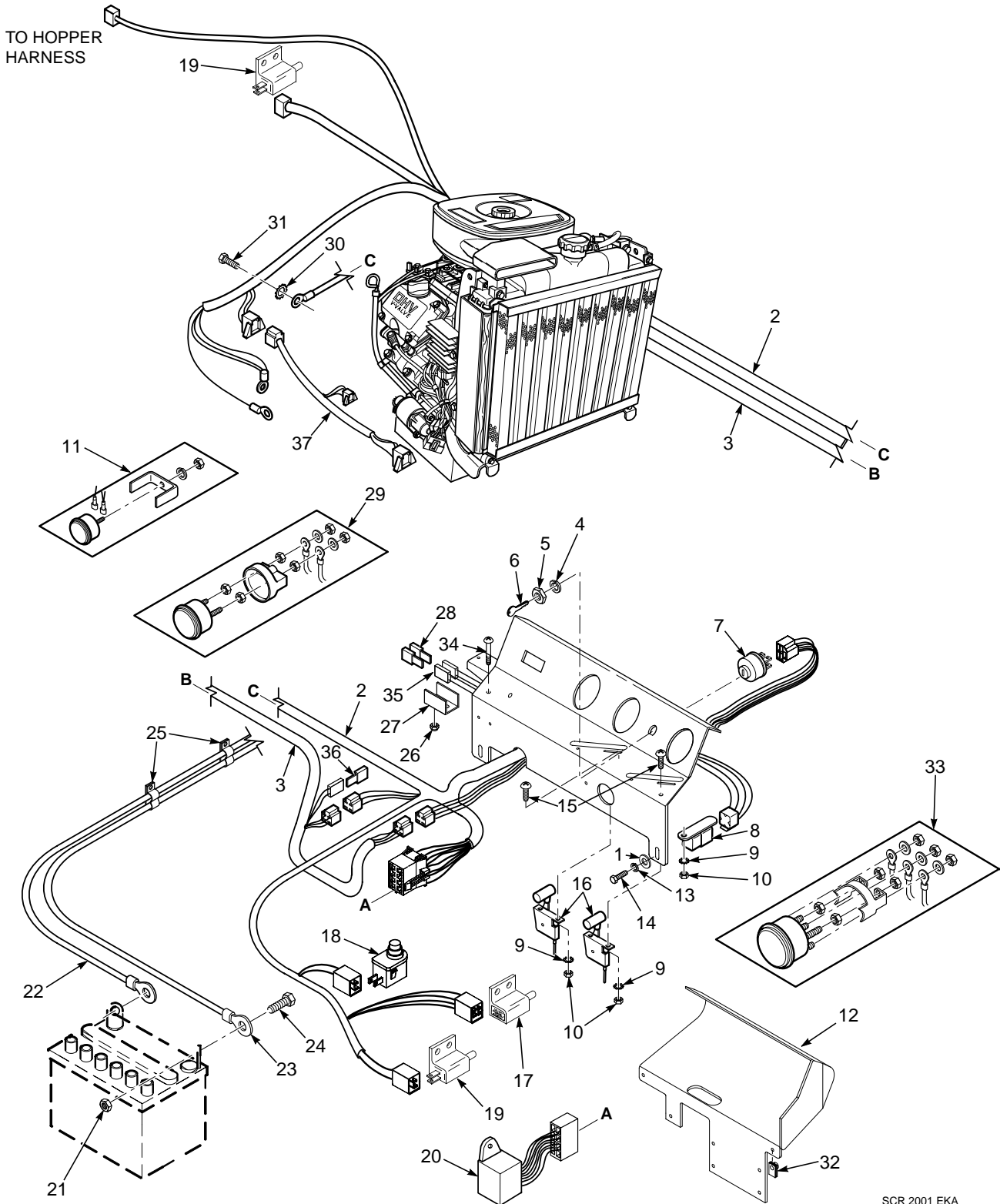

SCR 2001 EKA

KAWASAKI ELECTRICAL SYSTEM

Ref. Part. No. Number	Description	Ref. Part. No. Number	Description
1	04040-15 Flatwasher, 5/16-.375 x .875 x .083	21	04020-02 Nut, 1/4-20
2	482317 Wire Harness, SCR	22	48029-23 Battery Cable, Black
3	482319 Wire Harness, Hopper	23	48029-22 Battery Cable, Red
4	48017-03 Lockwasher, Internal 5/8"	24	04001-44 Bolt, Hex Head 1/4-20 x 1/2"
5	48017-04 Nut, 5/8-32 Special	25	48030-18 Cable Clamp, Double
6	48017-02 Key & Ring (includes 2 keys)	26	04021-01 Nut, Elastic Stop #10
7	48798 Keyswitch w/hardware	27	42413 Bracket, Fuse Holder
8	48788 Relay	28	48298 Fuse, 20 Amp
9	04031-01 Lockwasher, #10 external tooth	29	481755 Ammeter
10	04020-01 Nut, #10-32 UNF	30	04030-04 Lockwasher, 3/8"
11	48023 Hour Meter	31	04001-18 Bolt, Hex Head
12	451185 Instrument Panel, Lower	32	04110-02 U-Nut, 5/16-18
13	04030-03 Lockwasher, 5/16	33	481183 Water Temp Gauge
14	04001-09 Bolt, Hex Head 5/16-18 x 1"	34	04010-11 Screw, #10-32 x 1-1/2"
15	04010-01 Screw, #10-32 x 1/2"	35	48430 Fuse Holder W/Fuse & Connector
16	482032 Control Cable	36	482157 Fuse, 15 Amp
17	481545 Switch, PTO	37	482400 Wire Harness, Engine SCR 27KA
18	481638 Switch, Seat		
19	481637 Switch, Brake & Hopper		
20	482313 Interlock Module		

-NOTE-

Some of the hardware is common hardware and you may purchase it locally. Be sure that all bolts purchased locally are a grade 5.

HOPPER

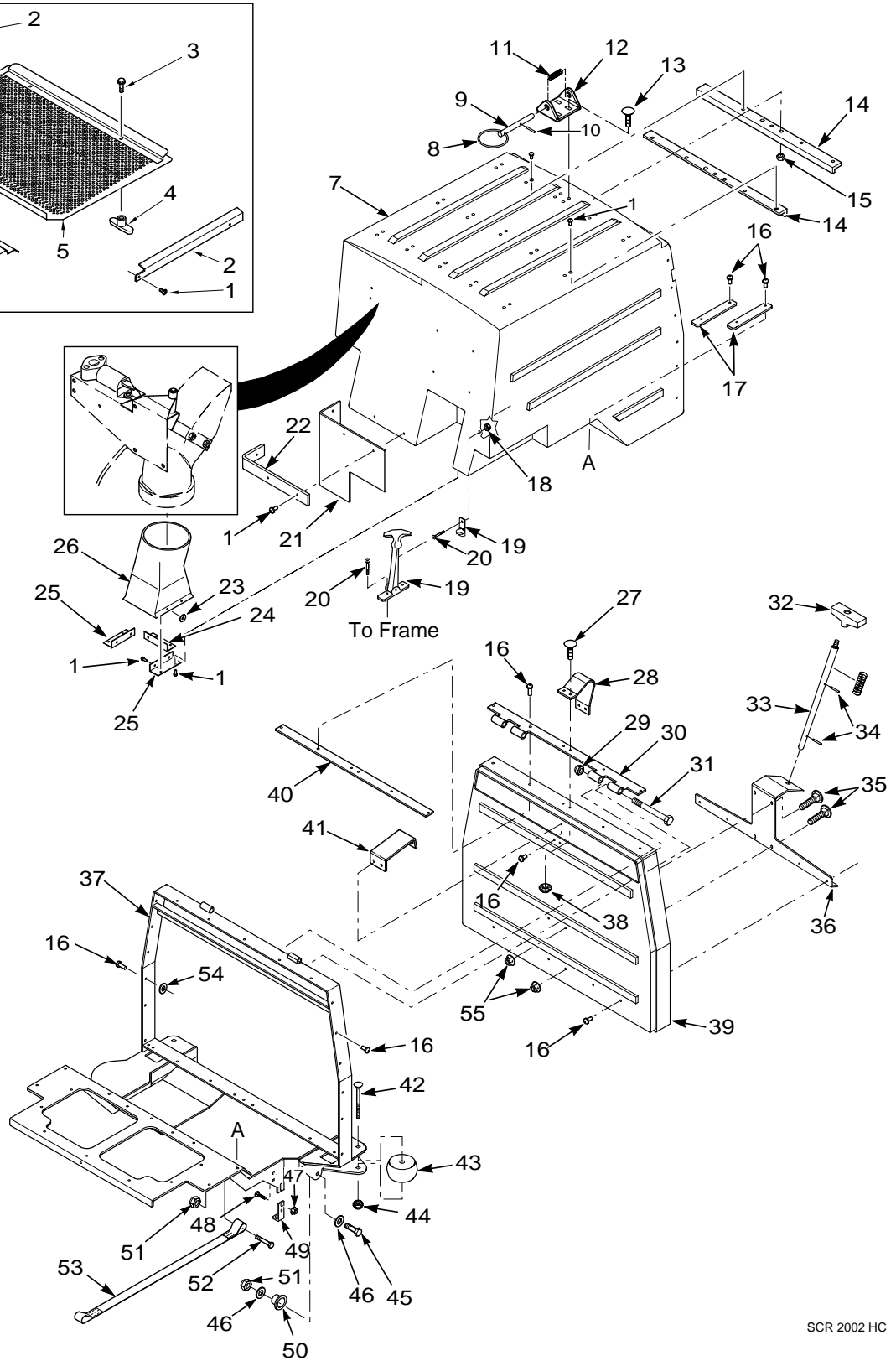
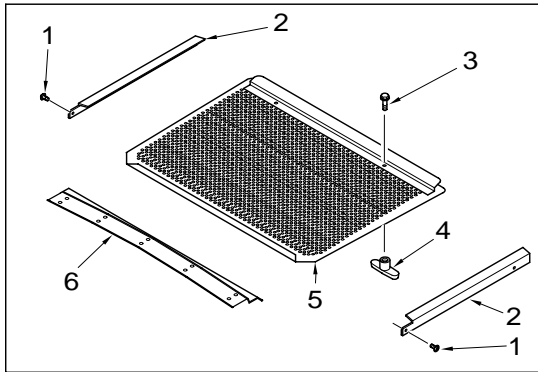

HOPPER

Ref. Part. No. Number Description	Ref. Part. No. Number Description
1 04090-02 Pop Rivet, 3/16 x .652	40 422932 Backing Strip, Hinge
2 451193 Guide Weldment, Screen	41 423131 Backing Plate, Door Latch
3 04001-08 Bolt, Hex Head 5/16-18 x 3/4"	42 04003-26 Bolt, Carr. 3/8-16 x 4"
4 481092-01 Plastic Knob, 5/16-18	43 481632 Wheel, Anti-Scalp
5 451191 Screen Weldment	44 04021-05 Lock Nut, 3/8-16
6 451289 Stop Weldment, Screen	45 04001-21 Bolt, Hex Head 3/8-16 x 1-3/4"
7 461474 Hopper Assembly (Incl. Items 1, 2, 4, 14, 16, 17, 21, 22, 24, 25, 37 & 54)	46 04041-07 Flatwasher, 3/8-.391 x .938 x .105
8 481876 Split Ring	47 04019-02 Nut, Serr. Flange 1/4-20
9 43548 Pin, Hopper Latch	48 04003-02 Bolt, Carr. 1/4-20 x 3/4"
10 04060-01 Roll Pin	49 423017 Bracket, Switch Mounting
11 482070 Spring, Door Lock	50 43546 Bushing, Hopper Pivot
12 422872 Mount, Latch Pin	51 04021-09 Nut, Elastic Stop 3/8-16
13 04003-06 Bolt, Carr. 1/4-20 x 1"	52 04001-62 Bolt, Hex Head 3/8-16 x 3-1/4"
14 422978 Support, Hopper Top	53 482071 Strap Bucket Stop
15 04019-02 Nut, Serr. Flange 1/4-20	54 04041-22 Flatwasher, 1/4-.258 x .50 x .0598
16 04091-01 Pop Rivet, 1/4 x .85	55 04019-03 Nut, Serr. Flange 5/16-18
17 423178 Retainer Strip, Hopper	
18 04021-01 Nut, Elastic Stop #10-32	
19 482409 Latch, Hopper	
20 04010-12 Screw, #10-32 x 3/4"	
21 482073 Pad, Rubber Heat Deflector	
22 423130 Backing PLate, Heat Deflector	
23 04040-14 Flatwasher, 1/4-.312 x .750 x .065	
24 422037 Mount, Transition Chute Rear	
25 422228 Mount, Transition Chute Side	
26 481279 Chute, Transition	
27 04003-06 Bolt, Carr. 1/4-20 x 1"	
28 422871 Latch, Hopper Door	
29 04021-10 Nut, Elastic Stop 5/16-18	
30 451189 Hinge Weldment, Hopper Door	
31 04001-126 Bolt, Hex Head 5/16-18 x 5-1/2"	
32 481092-01 Plastic Knob, 5/16-18	
33 43547 Pin, Hopper Door	
34 04060-08 Roll Pin, .188 x 1-1/2"	
35 04003-12 Bolt, Carr. 5/16-18 x 3/4"	
36 423128 Bracket, Door Latch	
37 451190 Hopper Frame Weldment	
38 04019-02 Nut, Serr. Flange 1/4-20	
39 481973 Door, Hopper	

-NOTE-

Some of the hardware is common hardware and you may purchase it locally. Be sure that all bolts purchased locally are a grade 5.

HOPPER ACTUATOR MECHANISM

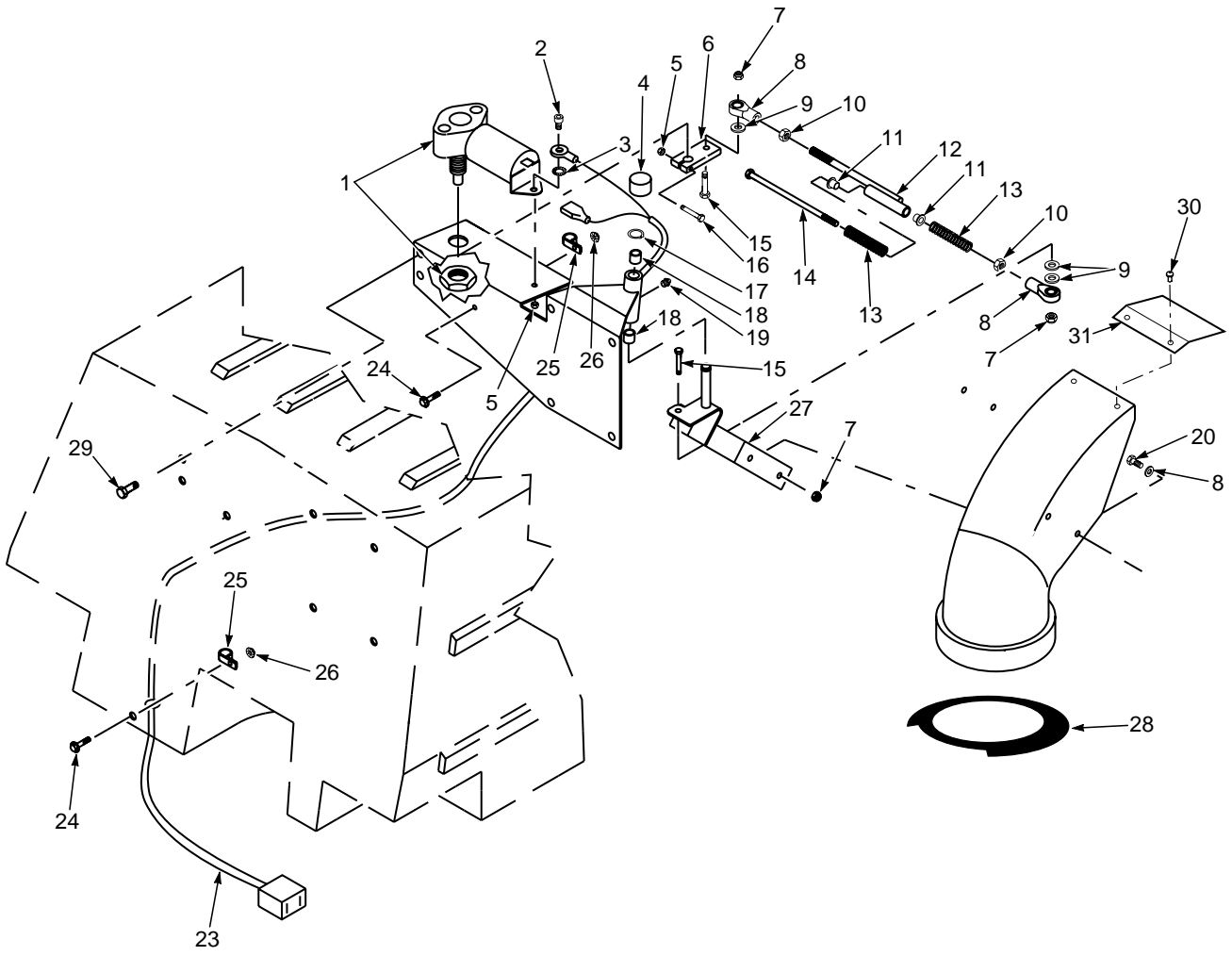

SCR 2002 HA

HOPPER ACTUATOR MECHANISM

Ref. Part. No. Number	Description
1	481254 Motor, Actuator
2	04015-05 Capscrew, Socket Head, #10-32 x 1/2"
3	04031-01 Washer, External
4	481285 Cap, Plastic
5	04021-01 Hex Locknut, Elastic Stop, #10-32
6	481291 Lever, Actuator
7	04021-10 Hex Locknut, Elastic Stop, 5/16-18
8	482072 Rod End, 5/16-24 R.H. Thread
9	04040-15 Flatwasher, 5/16 (.375 x .875 x .083)
10	04020-13 Hex Nut, 5/16-18
11	481354 Bushing, Nylon
12	45799 Connecting Rod
13	481344 Spring, Connecting Rod
14	04001-124 Bolt, Hex Head, 5/16-18 x 7.00"
15	04001-10 Bolt, Hex Head, 5/16-18 x 1-1/4"
16	04015-08 Capscrew, Socket Head, #10-32 x 1-1/2"
17	04050-10 Retainer Ring
18	48100-04 Bushing, Oilite, .502 ID
19	48114-05 Grease Fitting
20	04001-08 Bolt, Hex Head, 5/16-18 x 3/4"
21	461475 Chute
22	45777 Actuator Mount
23	482033 Wire Harness, Hopper
24	04003-02 Bolt, Carr. 1/4-20 x 3/4"
25	48030-09 Clamp, Cable, 1/2"
26	04019-02 Serr. Fl. Hex Nut, 1/4-20
27	45778 Pivot, Elbow
28	481408 Seal, Hopper Elbow
29	04006-01 Body Bolt, 5/16-18 x .81"
30	04090-02 Rivet
31	423477 Deflector, Hopper Chute

-NOTE-

Some of the hardware is common hardware and you may purchase it locally. Be sure that all bolts purchased locally are a grade 5.

REPLACEMENT DECALS AND INFORMATION PLATES

1

2

3

4

5

6

7

11

8

9

10

12

13

REPLACEMENT DECALS AND INFORMATION PLATES

Ref. No.	Part No.	Description
1	482285	Decal, Danger-Spinning Blades
2	482286	Decal, Warning-Rotating Blades
3	48656	Decal, Patents
4	482182	Decal, Blade Bolts LH Thread
5	482080	Decal, Rotating Blades
6	482255	Decal, Parking Brake
7	481039	Decal, Belt Cover
8	482288	Decal, Bystanders & Read Operator's Manual
9	482167	Decal, Start and Drive Procedure
10	482253	Decal, Forward Speed Selector
11	481863	Decal, Cutting Height
12	482257	Decal, Upper Instrument Panel - Kohler
	482258	Decal, Upper Instrument Panel - Kawasaki
13	482259	Decal, Lower Instrument Panel
14	481971	Decal, Heavy Duty
15	48314	Decal, SCAG
16	482052	Decal, Adjustments
17	48406	Decal, 42" Cutter Deck
	48318	Decal, 48" Cutter Deck
	48319	Decal, 52" Cutter Deck
18	48404	Decal, Made in the USA - Metalcraft of Mayville, Inc.
19	482251	Decal, PTO Engagement
20	482447	Decal, Driveshaft Grease



14



15



17

IMPORTANT ADJUSTMENT PROCEDURES
READ OPERATOR'S MANUAL FOR MORE DETAILS

Check tire pressure - (Drive tires - 12 PSI, All others - 25 PSI)

NEUTRAL ADJUSTMENT
 Adjust neutral only with drive wheels elevated and machine blocked securely. With speed control lever turnbuckle set at 5.5", pull speed control lever back to neutral. Apply brake and adjust turnbuckle until speed control lever contacts brake lever. When completed, neutral can be adjusted on machine. If wheels rotate forward when brake is released, adjust control rods CCW. If wheels rotate rearward, adjust control rods CW.

TRACKING ADJUSTMENT (Be sure both drive tires are inflated equally)
 If machine pulls to right, loosen jam nuts C & D on RH control rod and turn rod CW, tighten jam nuts and retest.
 If machine pulls to left, loosen jam nuts A & B on LH control rod and turn rod CW, tighten jam nuts and retest.

* LH Thread Rod End
 * LH Thread Rod End
 * LH threads identified with groove on shank of rod end body

Speed control Lever turnbuckle
 Speed control Lever

ALL gearbox Lubricant:
 SAE 80W90 Gear Oil

IMPORTANT
 GREASE SPINDLE, DRIVESHAFT AND BLOWER BEARINGS WEEKLY
 LITHIUM MP WHITE GREASE 2125

HYDRAULIC TANK FLUID LEVEL
 Check hydraulic fluid level daily while fluid is cool. Fluid level should be 2-1/2" below top of filler neck. Fill with SAE 20W50 motor oil only.

IMPORTANT!
 Do not overfill. Room for hot fluid expansion must be allowed or resulting expansion may cause leaks in the system.

FREE WHEEL OPERATION
 To move machine without running the engine, rotate both dump valve levers located at the front of the pumps CW 1/2 turn to "freewheel" positions. Return levers to original position to operate the mower.

16



48404

18

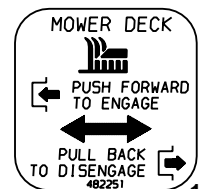

19

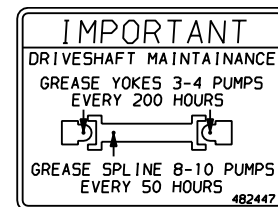

20

SCR 2K RD2

KOHLER ELECTRICAL SCHEMATIC

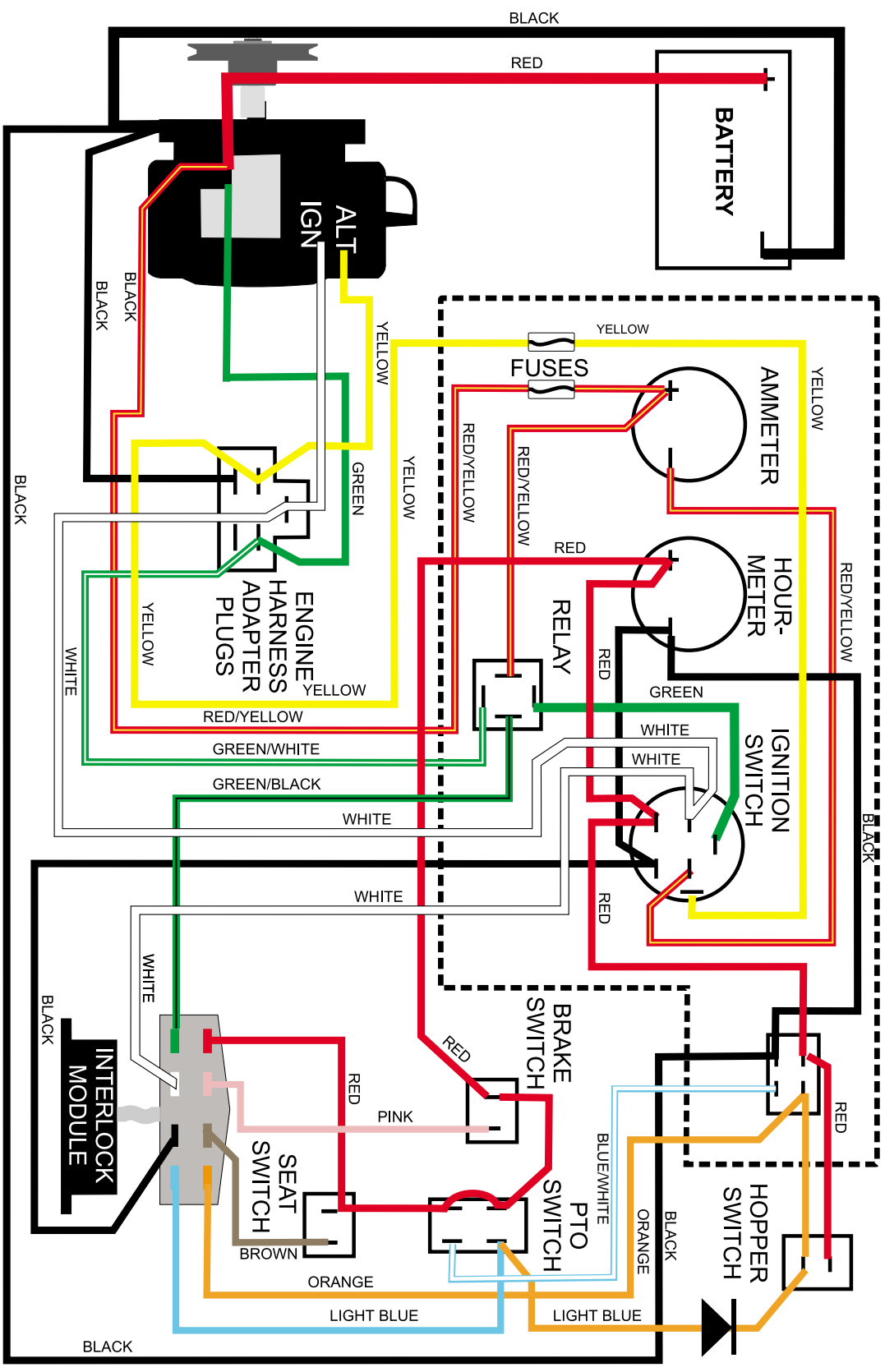

LIMITED WARRANTY - COMMERCIAL EQUIPMENT

Any part of the Scag commercial mower manufactured by Scag Power Equipment and found, in the reasonable judgment of Scag, to be defective in materials or workmanship, will be repaired or replaced by an Authorized Scag Service Dealer without charge for parts and labor. This warranty is limited to the original purchaser and is not transferable. Proof of purchase will be required by the dealer to substantiate any warranty claims. All warranty work must be performed by an Authorized Scag Service Dealer.

This warranty is limited to the following specified periods from the date of the original retail purchase for defects in materials or workmanship:

- * Wear items including drive belts, blades, hydraulic hoses and tires are warranted for ninety (90) days.
- * Batteries are covered for ninety (90) days.
- * Frame and structural components including oil reservoir, fittings, and oil coolers are warranted for 2 years (Parts and labor 1st year; Parts only 2nd year).
- * Cutter decks are warranted against cracking for a period of three (3) years. (Parts and labor 1st year; Parts only 2nd and 3rd year) The repair or replacement of the cutter deck will be at the option of Scag Power Equipment. We reserve the right to request components for evaluation. This warranty does not cover any mower that has been subject to misuse, neglect, negligence, or accident, or that has been operated in any way contrary to the operating instructions as specified in the Operator's Manual.
- * Engines and electric starters are covered by the engine manufacturer's warranty period.
- * Major drive system components are warranted for two (2) years by Scag Power Equipment. (Parts and labor 1st year; Parts only 2nd year) (Two year warranty exclude fittings, hoses, drive belts). The repair or replacement of the hydraulic pump or hydraulic motor will be at the option of Scag Power Equipment. This warranty does not cover any mower that has been subject to misuse, neglect, negligence, or accident, or that has been operated in any way contrary to the operating instructions as specified in the Operator's Manual.
- * Electric clutches have a Limited Warranty for 2 year (Parts and labor 1st year; Parts only 2nd year).
- * Cutter Spindle Assemblies 46631 have a Limited Warranty for three years (Parts and labor 1st year; Parts only 2nd and 3rd year).
- * Any Scag product used for rental purposes is covered by a 90 day warranty.

The Scag mower, including any defective part must be returned to an Authorized Scag Service Dealer within the warranty period. The expense of delivering the mower to the dealer for warranty work and the expense of returning it to the owner after repair will be paid for by the owner. Scag's responsibility is limited to making the required repairs and no claim of breach of warranty shall be cause for cancellation or rescission of the contract of sale of any Scag mower.

This warranty does not cover any mower that has been subject to misuse, neglect, negligence, or accident, or that has been operated in any way contrary to the operating instructions as specified in the Operator's Manual. The warranty does not apply to any damage to the mower that is the result of improper maintenance, or to any mower or parts that have not been assembled or installed as specified in the Operator's Manual and Assembly Manual. The warranty does not cover any mower that has been altered or modified, changing performance or durability. In addition, the warranty does not extend to repairs made necessary by normal wear, or by the use of parts or accessories which, in the reasonable judgment of Scag, are either incompatible with the Scag mower or adversely affect its operation, performance or durability.

Scag Power Equipment reserves the right to change or improve the design of any mower without assuming any obligation to modify any mower previously manufactured. All other implied warranties are limited in duration to the two (2) year warranty period or ninety (90) days for mowers used for rental purpose. Accordingly, any such implied warranties including merchantability, fitness for a particular purpose, or otherwise, are disclaimed in their entirety after the expiration of the appropriate two year or ninety day warranty period. Scag's obligation under this warranty is strictly and exclusively limited to the repair or replacement of defective parts and Scag does not assume or authorize anyone to assume for them any other obligation. Some states do not allow limitations on how long an implied warranty lasts, so the above limitation may not apply to you.

Scag assumes no responsibility for incidental, consequential or other damages including, but not limited to, expense for gasoline, expense of delivering the mower to an Authorized Scag Service Dealer and expense of returning it to the owner, mechanic's travel time, telephone or telegram charges, rental of a like product during the time warranty repairs are being performed, travel, loss or damage to personal property, loss of revenue, loss of use of the mower, loss of time or inconvenience. Some states do not allow the exclusion or limitation of incidental or consequential damages, so the above limitation or exclusion may not apply to you. This warranty gives you specific legal rights, and you may also have other rights which vary from state to state.

© 2002
SCAG POWER EQUIPMENT
DIVISION OF METALCRAFT OF MAYVILLE, INC.

PART NO. 03103
PRINTED 3/02
PRINTED IN USA

KAWASAKI ELECTRICAL SCHEMATIC

