

**HONDA**

**Power**

**Equipment**

# Owner's Manual

## Rotary Mower

### HRS21

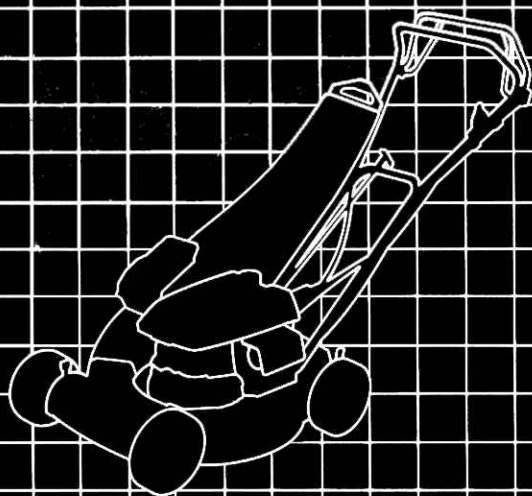

---

Thank you for purchasing a Honda mower.

This manual covers operation and maintenance of Honda HRS21 rotary mowers, type SA (self-propelled, rear bag), type SVA (self-propelled, side discharge), type PA (manually propelled, rear bag), and type PVA (manually propelled, side discharge). Illustrations in this manual are based on type SA, unless otherwise noted. Honda HRS21 mowers meet CPSC blade safety requirements for walk-behind rotary power mowers. Honda Motor Co., Ltd. reserves the right to make changes at any time without notice and without incurring any obligation.

No part of this publication may be reproduced without written permission.

This manual should be considered a permanent part of the mower and remain with the mower when sold.

Pay special attention to statements preceded by the following words;

 **WARNING** Indicates a strong possibility of severe personal injury or loss of life if instructions are not followed.

**CAUTION:** Indicates a possibility of personal injury or equipment damage if instructions are not followed.

**NOTE:** Gives helpful information.

If a problem should arise, or if you have any questions about the mower, consult an authorized Honda dealer.

HONDA MOTOR CO., LTD. 1983, ALL RIGHTS RESERVED

---

**WARNING**

- The Honda rotary mower is designed to give safe and dependable service if operated according to instructions and intended use: mowing (cutting) grass, and bagging cut grass when equipped with the grass bag. Any other use could be dangerous.
- Read and understand the Owner's Manual before operating the mower. Failure to do so could result in personal injury or equipment damage.

## CONTENTS

1 CAUTION LABEL LOCATION .....	4
2 GENERAL SAFETY .....	6
3 COMPONENT IDENTIFICATION .....	7
4 CONTROLS .....	9
5 OPERATION .....	11
6 BEFORE YOU START THE MOWER .....	12
7 STARTING AND STOPPING THE ENGINE .....	17
• High altitude operation .....	20
8 TRANSPORTING/STORAGE .....	23
9 MAINTENANCE .....	26
10 TROUBLESHOOTING .....	36
11 SPECIFICATIONS .....	37
12 WARRANTY SERVICE .....	38

# 1. CAUTION LABEL LOCATIONS

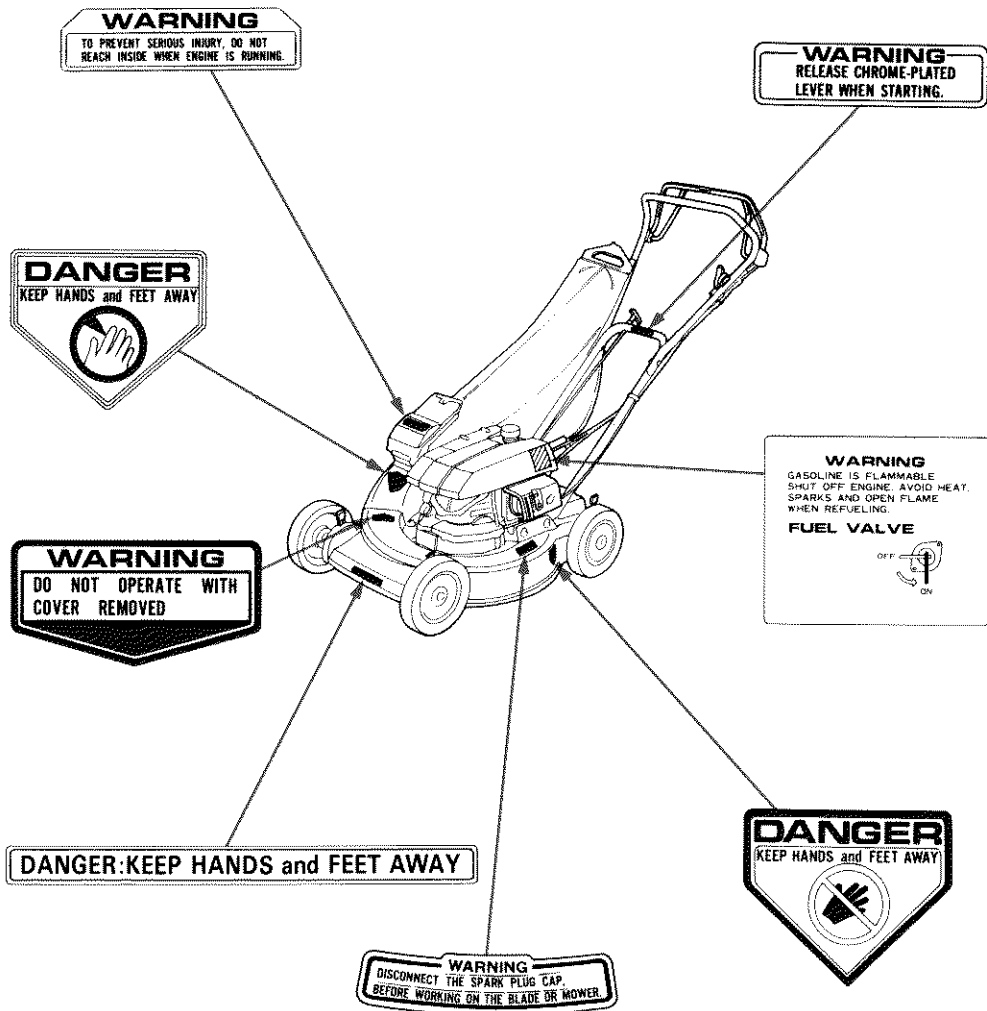

(SA type)

**BLADE CONTROL** HOLD AGAINST HANDLE BEFORE STARTING ENGINE. RELEASE TO STOP ENGINE.

**AIR CLEANER MAINTENANCE**

CLEAN THE FILTER ELEMENTS EVERY 50 HOURS, AS DESCRIBED IN THE OWNER'S MANUAL. CLEAN MORE FREQUENTLY WHEN USED IN DUSTY AREAS.

**HONDA HR621**

**WARNING**  
#READ OWNER'S MANUAL BEFORE OPERATING.  
#DO NOT ALLOW ANYONE TO STAND IN FRONT OF MOWER.  
#TO PREVENT INJURY FROM THROWN OBJECTS, CLEAR AREA OF DEBRIS. KEEP OTHERS AWAY.  
#DO NOT START UNLESS DISCHARGE GUARD IS CLOSED OR RAD IS IN PLACE.  
SAGGING MODEL: DISCHARGE ADAPTER IS IN PLACE.



**DANGER: KEEP HANDS and FEET AWAY**



(SVA type)

## 2. GENERAL SAFETY

---

### WARNING

- Know how to stop the engine quickly and understand operation of all the controls. Never permit anyone to operate the mower without proper instruction.
- The rear shield is for your protection; keep it in place at all times.
- The blade is sharp and dangerous. Never put your hands or feet under the mower. Never tilt the mower to expose the blade while the engine is running. If you find it necessary to work on the blade or mower, stop the engine and remove the spark plug cap.
- Never stand in front of self-propelled mowers when the engine is running. Someone may accidentally engage the drive clutch.
- Clear the lawn of sticks, stones, or debris before mowing. Mow only in cleared areas in daylight or good artificial light.
- Protect yourself by wearing long trousers and appropriate shoes. Don't wear loose fitting clothing or sandals when mowing.
- Keep children and pets away from the mower at all times.
- If the blade strikes a stone, sprinkler head, etc., be sure the blade, blade holder, woodruff key, fasteners, crankshaft, etc. are in good condition before continuing to mow.  
Replace any damaged parts.
- Never operate without the grass bag or discharge adaptor.

### 3. COMPONENT IDENTIFICATION

---

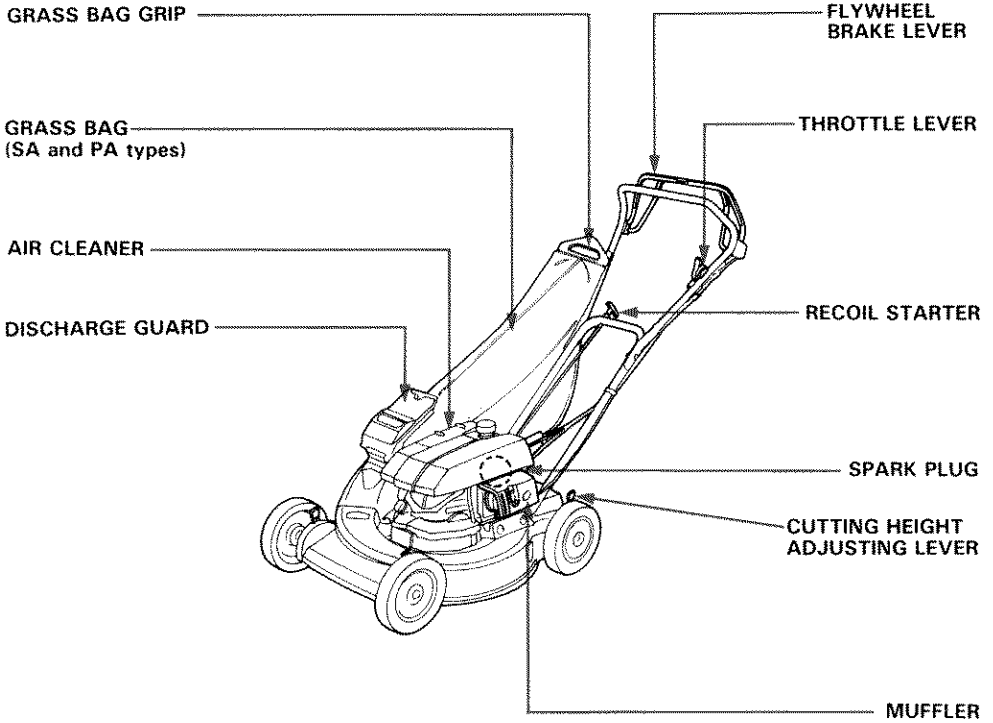

(SA type)



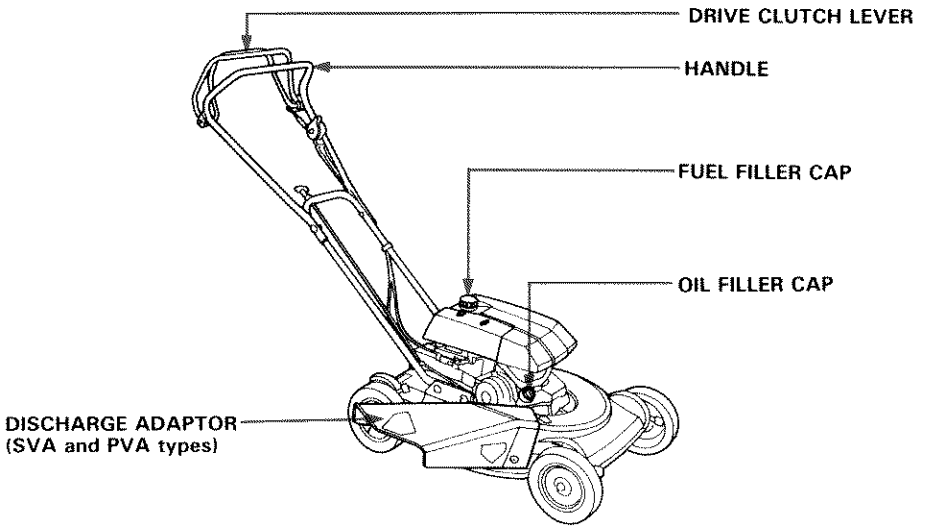

**(SVA type)**

### Throttle Control Lever

Throttle positions: START (CHOKE)  
HI  
LO

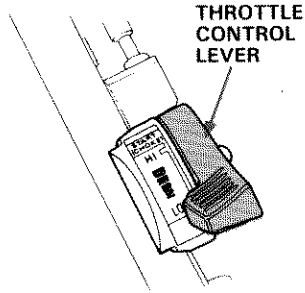

### Flywheel Brake Lever (Black-painted lever)

The flywheel brake lever must be moved forward and held against the handlebar to allow the engine to start and run. When the flywheel brake lever is released, the engine stops.

**CAUTION:** If the Brake System fails to stop the engine, turn off the fuel valve and allow the engine to stop completely.

Take the mower to an authorized Honda dealer for service. (See p. 19).

FLYWHEEL BRAKE LEVER

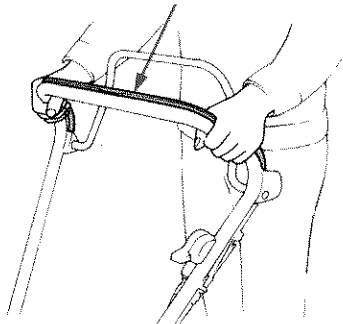

---

## Drive Clutch Lever (Self-propelled type)

To propel the mower, move the drive clutch lever forward against the handlebar with one hand, while holding the flywheel brake lever against the handlebar with the other hand. Both levers can be held against the handlebar with one hand while the mower is being operated.

Release the drive clutch lever to disengage the drive.

NOTE: If the flywheel brake lever is also released, the engine will stop.

**CAUTION:** The drive clutch lever must be released for starting, otherwise the mower will move forward when the starter is pulled.

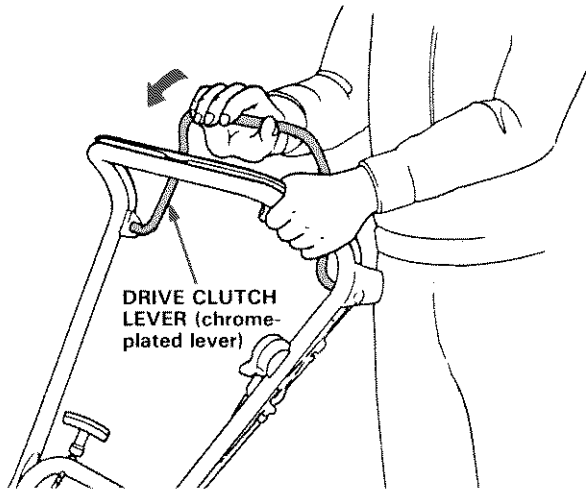

## 5. OPERATION

---

This MOWER should be used with the grass bag or discharge adaptor. The following suggestions and rules are intended to help you operate your Honda HRS21 under the safest conditions possible. Be alert and exercise the same care using the mower as you would using any other power tool.

### WARNING

- Be especially careful when mowing uneven or rough ground. The mower may tilt, exposing the blade, and hidden objects could be thrown by the blade. Keep all four wheels on the ground.
- Mow across slopes. Do not mow excessively steep slopes.
- Control direction by the handle, not by foot pressure on the mower housing.
- Keep a firm hold on the handle and walk, never run, with the mower. Don't lag behind the machine or let it pull you.

### CAUTION:

- Use extra care when mowing around objects to keep the blade from striking them. Never deliberately mow over any object.
- Stop the engine immediately if the blade hits an object or the mower starts to vibrate. Remove the spark plug cap (keep the wire away from the plug) and inspect for damage.

NOTE: (Self-propelled type) Do not use the drive clutch when maneuvering around trees, etc.

Release the clutch and push the mower for better directional control.

## 6. BEFORE YOU START THE MOWER

---

### 1. Check the engine oil level.

#### CAUTION:

- Engine oil is a major factor affecting engine performance and service life. Non-detergent oil and 2-stroke engine oil are not recommended.
- Running the engine with insufficient oil can cause serious engine damage.

Use Honda-4-stroke, or an equivalent high detergent, premium quality motor oil certified to meet or exceed U.S. automobile manufacturers' requirements for service classification SE or SF (Motor oils classified SE or SF will show this designation on the container).

SAE 10W-40 is recommended for general, all temperature use.

- a. Place the mower on a level surface.
- b. Remove the oil filler cap and wipe the dipstick clean.
- c. Insert the dipstick into the oil filler neck, but do not screw it in.
- d. Check the oil level shown on the dipstick. If near the lower level, fill to the upper level with the recommended oil.

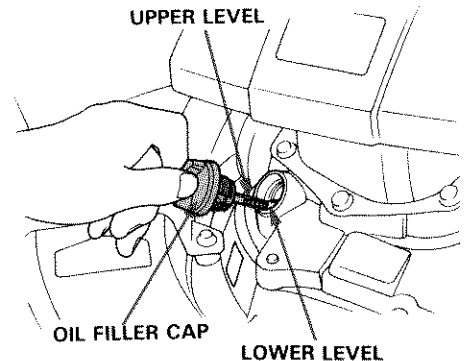
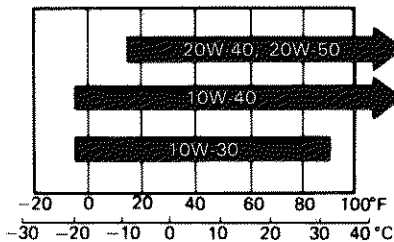

---

## 2. Check the fuel level.

Your engine is designed to use any gasoline that has a pump octane number ( $\frac{R+M}{2}$ ) of 86 or higher, or that has a research octane number of 91 or higher. Gasoline pumps at service station normally display the pump octane number.

We recommend that you use unleaded fuel because it produces fewer engine and spark plug deposits and extends the life of exhaust system components.

Never use stale or contaminated gasoline or an oil/gasoline mixture. Avoid getting dirt, dust or water in the fuel tank. Use of a lower octane gasoline can cause persistent "pinging" or heavy "spark knock" (a metallic rapping noise) which, if severe, can lead to engine damage.

**CAUTION:** If "spark knock" or "pinging" occurs at a steady engine speed under normal load, change brands of gasoline. If spark knock or pinging persists, consult your authorized Honda dealer. Failure to do so is considered misuse, and damage caused by misuse is not covered by Honda's Limited Warranty.

Occasionally you may experience light spark knock while operating under heavy loads. This is no cause for concern, it simply means your engine is operating efficiently.

### WARNING

- Gasoline is extremely flammable and is explosive under certain conditions.
- Refuel in a well-ventilated area with the engine stopped. Do not smoke or allow flames or sparks in the area where the engine is refueled or where gasoline is stored.
- Do not overfill the fuel tank (there should be no fuel in the filler neck). After refueling, make sure the tank cap is closed properly and securely.
- Be careful not to spill fuel when refueling. Spilled fuel or fuel vapor may ignite. If any fuel is spilled, make sure the area is dry before starting the engine.
- Avoid repeated or prolonged contact with skin or breathing of vapor. **KEEP OUT OF REACH OF CHILDREN.**

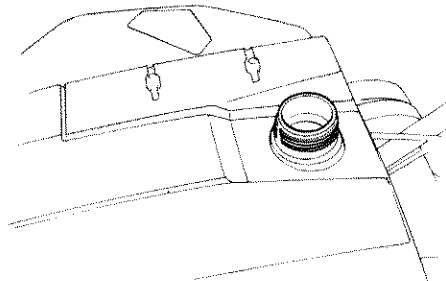

---

## **GASOLINES CONTAINING ALCOHOL**

If you decide to use a gasoline containing alcohol (gasohol), be sure it's octane rating is at least as high as that recommended by Honda. There are two types of "gasohol": one containing ethanol, and the other containing methanol. Do not use gasohol that contains more than 10% ethanol. Do not use gasoline containing methanol (methyl or wood alcohol) that does not also contain cosolvents and corrosion inhibitors for methanol. Never use gasoline containing more than 5% methanol, even if it has cosolvents and corrosion inhibitors.

### **NOTE:**

- Fuel system damage or engine performance problems resulting from the use of fuels that contain alcohol is not covered under the warranty. Honda cannot endorse the use of fuels containing methanol since evidence of their suitability is as yet incomplete.
- Before buying fuel from an unfamiliar station, try to find out if the fuel contains alcohol, if it does, confirm the type and percentage of alcohol used. If you notice any undesirable operating symptoms while using a gasoline that contains alcohol, or one that you think contains alcohol, switch to a gasoline that you know does not contain alcohol.

---

### 3. Check the grass bag and discharge adaptor.

#### If equipped with a grass bag:

Check the grass bag for fraying, tears and clogged mesh. Wash the bag with water if necessary, and let it dry thoroughly. Grass will not chute properly without adequate ventilation through the bag.

Make sure the bag is properly installed and the fastener is securely closed.

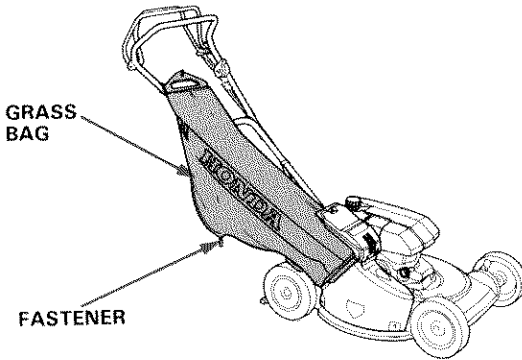

#### If equipped with a discharge adaptor:

Make sure the adaptor is properly installed. Check the adaptor mounting bolts and nuts (p. 22) to be sure they are tightened and undamaged.

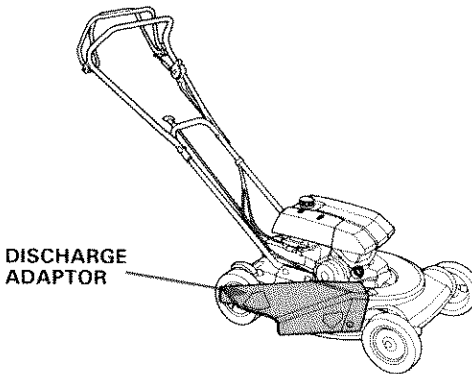



---

4. Check the blade bolts for tightness.

Torque: 5.0—6.0 kg-m (36.2—43.4 ft-lb)

**WARNING** To be certain that the engine will not start accidentally, remove the spark plug cap before performing this inspection.

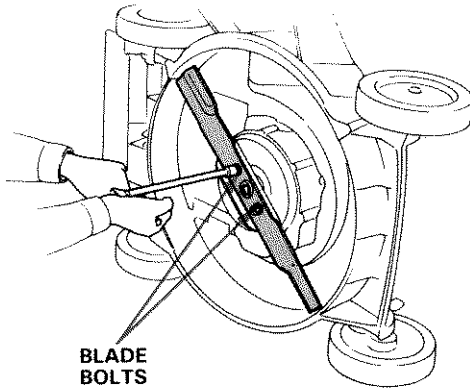

5. Check the air cleaner element and clean it if it is dirty (p.29)

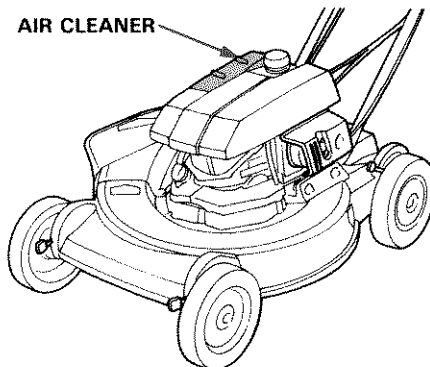

## 7. STARTING AND STOPPING THE ENGINE

### Starting the Engine

**WARNING** Exhaust gas contains poisonous carbon monoxide. Never run the mower in an enclosed area. Be sure to provide adequate ventilation.

1. Turn the fuel valve ON.
2. Move the throttle lever to START(CHOKE).

**NOTE:** If the engine is warm or the air temperature is high, move the throttle to LO as soon as the engine starts.

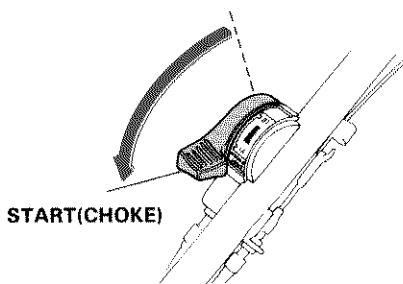
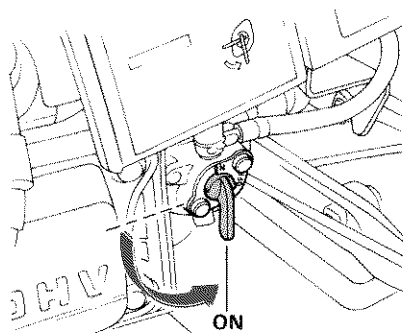

3. Move the flywheel brake lever forward and hold it against the handlebar.

FLYWHEEL BRAKE LEVER

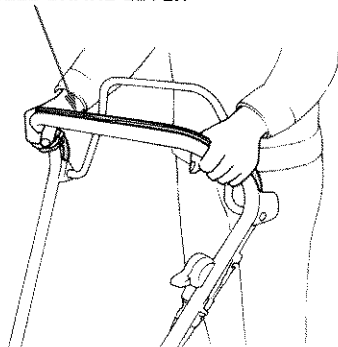

---

4. Pull the starter rope lightly until you feel resistance, then pull briskly.

NOTE: Do not allow the rope to snap back; return it by hand.

5. After the engine warms up, move the throttle lever to HI.

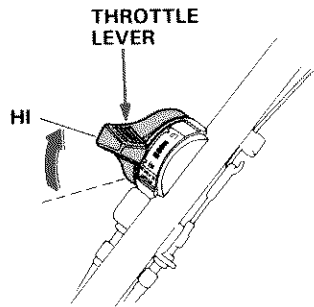
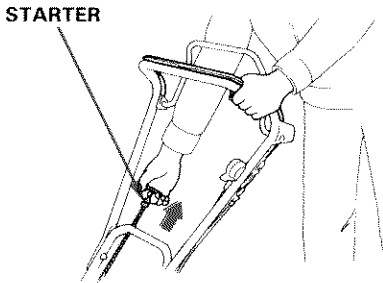

Self-propelled type only:

Push the drive clutch lever forward to propel the mower.

NOTE: The throttle lever may be moved anywhere between HI and LO to adjust engine speed during operation. However, the engine may stall if the lever is at LO when mowing starts.

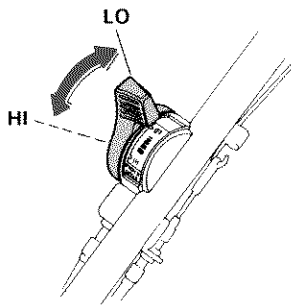

---

## Flooded Engine

If the engine won't start after several pulls on the starter rope, the engine may be flooded.

To clear a flooded engine:

1. Turn off the fuel valve.
2. Remove the spark plug and dry it. When reinstalling the plug, thread it in by hand until it seats. Then tighten it an additional 1/8-1/4 turn with the spark plug wrench to compress the washer.
3. Move the throttle to HI, turn on the fuel valve and repeat steps 3-5 under "Starting the Engine".

## Stopping the Engine

1. Release the drive clutch (self-propelled type only) and flywheel brake lever.
2. Turn off the fuel valve.

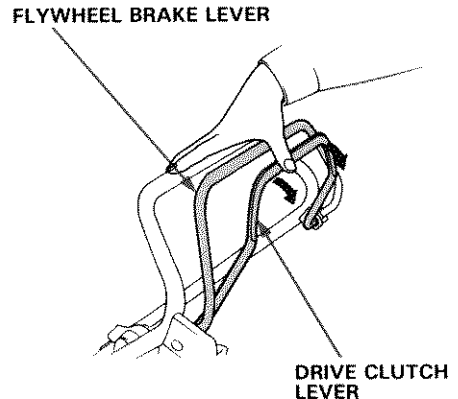
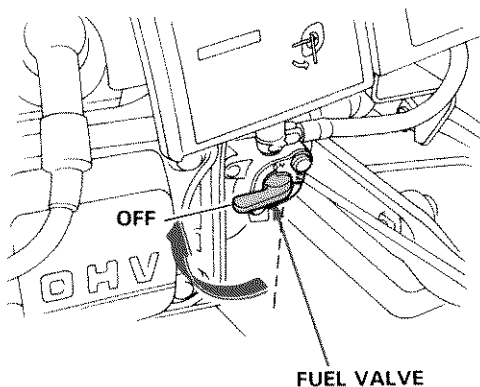

---

- **High altitude operation**

At high altitude, the standard carburetor air-fuel mixture will be excessively rich. Performance will decrease, and fuel consumption will increase.

High altitude performance can be improved by installing a smaller diameter main fuel jet in the carburetor and readjusting the pilot screw. If you always operate the rotary mower at altitudes higher than 6,000 feet above sea level, have your authorized Honda Rotary Mower dealer perform these carburetor modifications.

Even with suitable carburetor jetting, engine horsepower will decrease approximately 3.5% for each 1,000 foot increase in altitude. The affect of altitude on horsepower will be greater than this if no carburetor modification is made.

**CAUTION: Operation of the mower at an altitude lower than the carburetor is jetted for may result in reduced performance, overheating, and serious engine damage caused by an excessively lean air/fuel mixture.**

### Cutting Height Adjustment

Six settings are available: 3/4", 1", 1-1/2", 2", 2-1/2", 3".

1. Stop the engine.
2. Push the front and rear adjusting levers toward the wheels and move them up or down to raise or lower cutting height. Adjust all four wheels to the same height.



**WARNING** Be careful not to touch the muffler when adjusting the left rear wheel height.

The muffler will stay hot for a while after the engine is stopped.

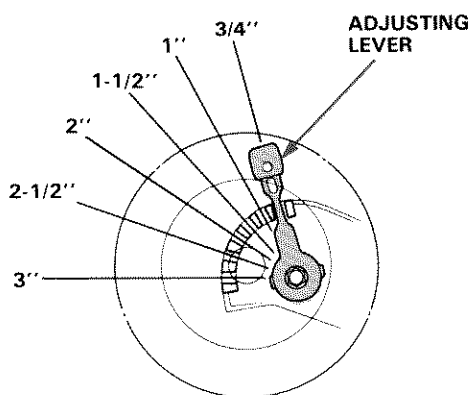
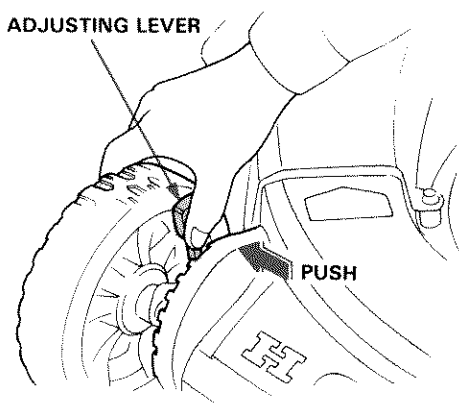

---

## Grass Bag

The bag is subject to wear under normal usage; check frequently for fraying and tears. Replace deteriorated bags only with Honda replacement bags or their equivalent. When the bag needs cleaning, wash it with water and make sure it is dry before using it.

Clogged mesh will result in poor grass chuting and a wet bag will clog quickly.

### Removal

1. Stop the engine.
2. Raise the discharge guard. Grasp the bag handle. Remove and raise the front end of the grass bag.
3. Unhook the rear bag grip, and remove the bag.
4. Open the fastener to empty the bag.

### Installation

1. Close the grass bag fastener.
2. Hook the rear bag grip on the handlebar hook.
3. Open the discharge guard and set the front end of the bag frame onto the recesses.

**WARNING** Make sure the grass bag fastener is securely closed before installation.

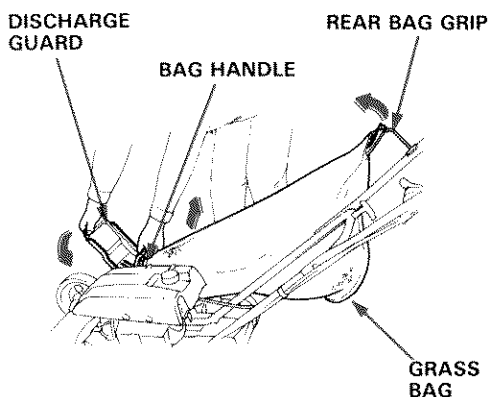

---

## Discharge Adaptor

The adaptor is subject to wear under normal usage; check frequently for damage, and make sure the nuts and bolts are tightened. Replace, if damaged, with a Honda genuine adaptor.

When the adaptor needs cleaning, wash it with water and dry it thoroughly before using.

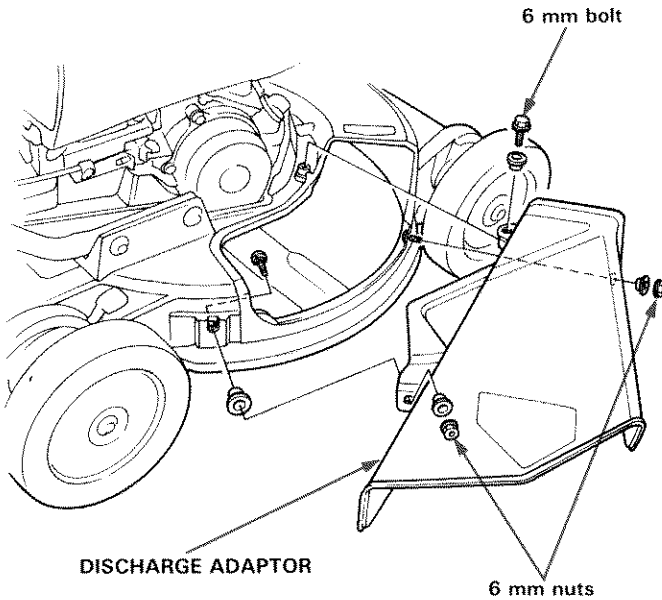

(PVA and SVA types)

## 8. TRANSPORTING/STORAGE

### Transporting

Turn the fuel valve OFF when transporting the mower.



**WARNING** To avoid fuel and oil spillage do not tilt the unit; spilled fuel may ignite.

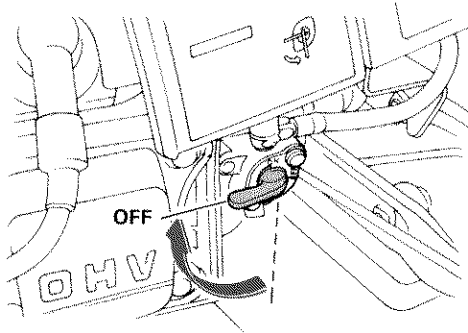

### Preparation for Storage

The following steps should be taken to protect the mower whenever it will be stored for longer than 30 days.

1. Drain the fuel tank and carburetor into a suitable gasoline container:
  - A. Disconnect the fuel tube from the carburetor and drain the fuel tank.

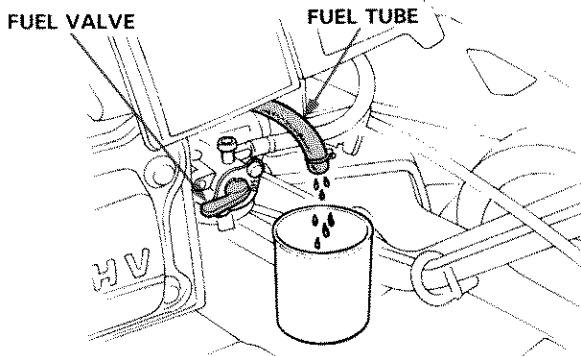



---

B. Remove the carburetor bowl to drain the carburetor.



**WARNING** Gasoline is extremely flammable and explosive under certain conditions. Do not smoke or allow flames or sparks in the area.

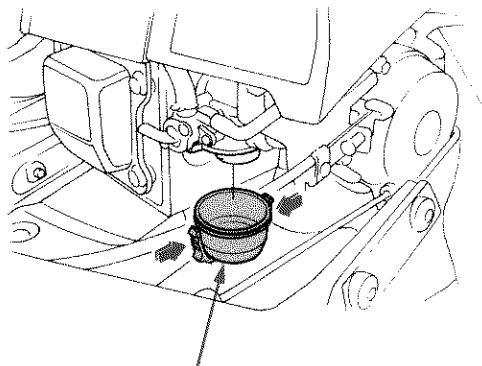

CARBURETOR BOWL

C. Reinstall the bowl, connect the fuel tube and turn the fuel valve off.

2. Change the engine oil (p. 28).

3. Pull the starter rope until resistance is felt. This closes the valves and helps to protect the combustion chamber from corrosion.

4. Coat areas that may rust with a light film of oil. Cover the mower and store it on a level surface in a dry, dust free area.

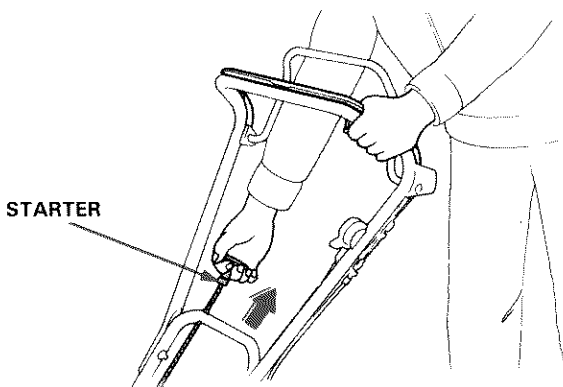

---

**NOTE:** If the mower will be stored for longer than 3 months, remove the spark plug and pour three tablespoonsful of clean motor oil into the cylinder. Pull the starter rope slowly two or three times to distribute the oil. Replace the plug.

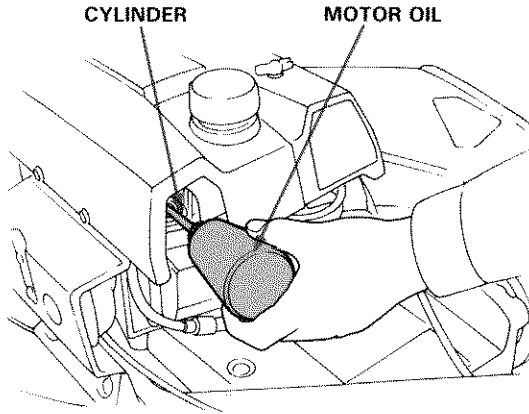

### **Removal from Storage**

1. Remove the spark plug; check that it is clean and properly gapped (p. 29). Pull the starter rope several times.
2. Thread the spark plug in by hand until it seats, then use the plug wrench to tighten  $1/8$  to  $1/4$  turn further.
3. Check the engine oil level and condition.
4. Fill the fuel tank and start the engine.

**NOTE:** If the cylinder was coated with oil, the engine will smoke at start up; this is normal.

## 9. MAINTENANCE

---



**WARNING** To prevent accidental start-up, shut off the engine and disconnect the spark plug cap before performing any maintenance.

**CAUTION:** Use only genuine Honda parts or their equivalent for maintenance or repair. Replacement parts which are not of equivalent quality may damage the mower.

Periodic inspection and adjustment of the Honda HRS21 are essential if high level performance is to be maintained. Regular maintenance will also help to extend service life. The required service intervals and the kind of maintenance to be performed are described in the chart on the following page.

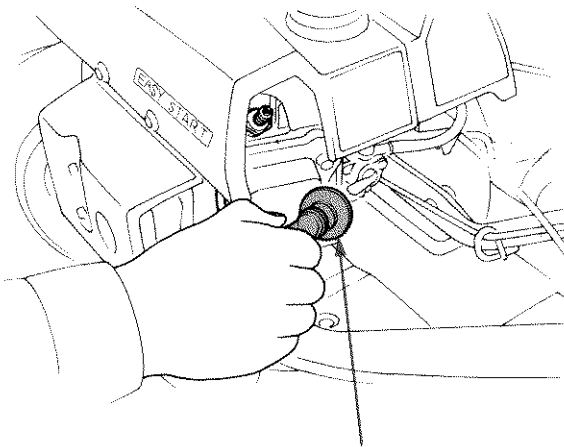

SPARK PLUG CAP

## Maintenance Schedule

ITEM	REGULAR SERVICE PERIOD (3) Perform at every indicated month or operating hour interval, whichever comes first.		Each Use	First month or 20 Hrs.	Every 3 months or 50 Hrs.	Every 6 months or 100 Hrs.	Every Year or 300 Hrs.
Engine oil	Check level		○				
	Change			○		○	
Air cleaner element	Check		○				
	Clean				○(1)		
Spark plug	Clean-Adjust					○	
Blade nuts (Tightness)	Check		○				
Blad holder washer	Check (Replace, if necessary)					○(2)	
Grass bag or discharge adaptor	Check-Clean		○				
Throttle cable	Adjust						○
Drive clutch cable	Adjust						○
Brake cable	Adjust				○		
Flywheel brake pad	Check				○(2)		
Spark arrester (optional)	Clean					○	
Valve clearance	Check-Adjust						○(2)
Fuel tank and Fuel strainer	Clean						○(2)
Fuel tube	Check (Replace, if necessary)	Every 3 years (2)					

- (1) Service the air cleaner more frequently when used in dusty areas.
- (2) These items should be serviced by an authorized Honda dealer, unless the owner has the proper tools and is mechanically proficient.  
See the Honda Shop Manual.
- (3) For professional commercial use, log hours of operation to determine proper maintenance intervals.

---

## Engine Oil Change

Drain the oil while the engine is still warm to assure rapid and complete draining.

1. Remove the filler cap.
2. Tilt the mower to drain the oil.

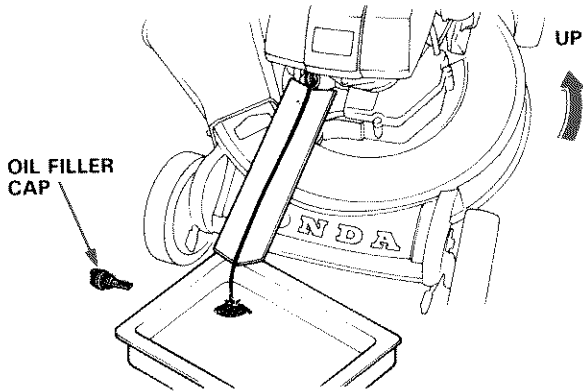

3. Refill to the "Upper" level mark with the recommended oil (see p.12). Tighten the cap securely to prevent leakage.

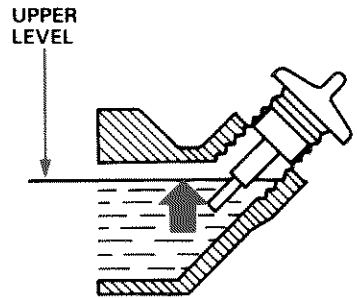
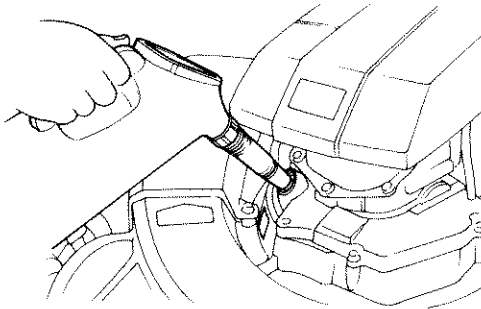

**CAUTION:** Used motor oil may cause skin cancer if repeatedly left in contact with the skin for prolonged periods. Although this is unlikely unless you handle used oil on a daily basis, it is still advisable to thoroughly wash your hands with soap and water as soon as possible after handling used oil.

**NOTE:** Please dispose of used motor oil in a manner that is compatible with the environment. We suggest you take it in a sealed container to your local service station for reclamation. Do not throw it in the trash or pour it on the ground.

---

## Air Cleaner Service

A dirty air cleaner will restrict air flow to the carburetor. To prevent carburetor malfunction, service the air cleaner frequently.

1. Remove the wing nuts and the air cleaner cover.  
Remove the element.  
Carefully check the element for holes or tears and replace if damaged.
2. Tap the element lightly several times on a hard surface to remove excess dirt, or blow compressed air through the filter from the inside out.  
Never try to brush the dirt off; brushing will force dirt into the fibers.  
If the element is excessively dirty, replace it.

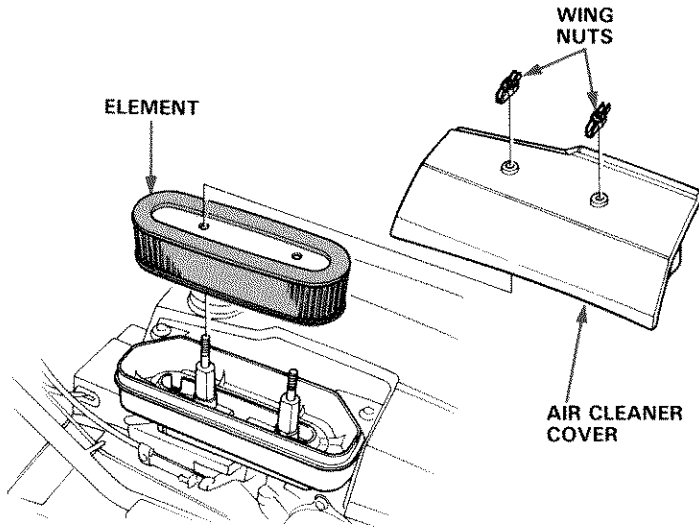

---

## Spark Plug

Standard Plug: BR-4HS (NGK)  
W14FR-U (ND)

1. Disconnect the cap and remove the spark plug.
2. Visually inspect the plug. Discard the plug if it is heavily deposited or if the insulator is cracked or chipped.
3. Measure the plug gap with a wire-type feeler gauge; it should be 0.7–0.8 mm (0.028–0.031 in). If adjustment is necessary, bend the side electrode carefully.
4. Make sure the sealing washer is in good condition, then thread the spark plug in by hand until it seats.
5. Use the wrench to tighten a new plug 1/2 turn further to compress the washer. If you are reusing the plug, it should only take 1/8–1/4 turn after the plug seats.
6. Replace the spark plug cap.

SPARK PLUG WRENCH

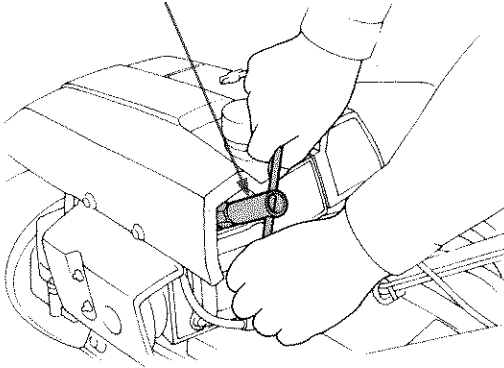

SIDE ELECTRODE

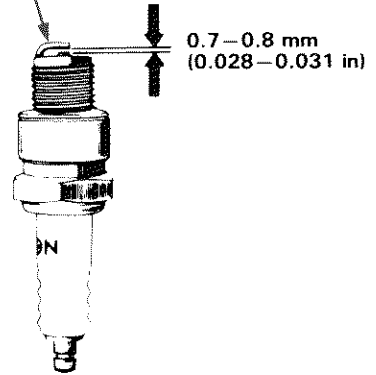

## Blade Removal and Sharpening

### WARNING

- Wear heavy gloves to protect your hands.
- Disconnect the spark plug cap to prevent accidental start-up.

1. Turn the fuel valve OFF, and drain the carburetor (see p. 24).
2. Tilt the mower so the carburetor side is up.  
Remove the blade nuts to remove the blade.

#### NOTE:

Never tilt the mower so the carburetor side is down.  
It will result in hard starting.

3. Sharpen the blade cutting edges with a file. File the top side only. Maintain the original bevel for a fine cutting edge. File both ends evenly to maintain blade balance.

#### NOTE:

Use only a genuine HONDA replacement blade or equivalent.

4. Clean away any dirt and grass from around the blade shaft.
5. Install the blade so that the blade bolts are securely tightened to the specified torque.  
Torque: 5.0–6.0 kg-m (36.2–43.4 ft lb)

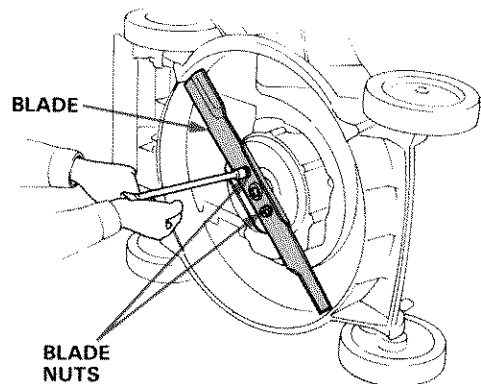
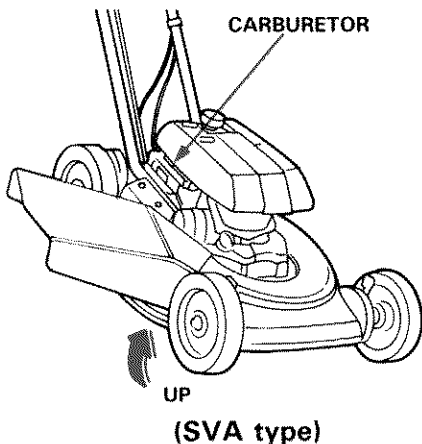



---

## Throttle Control Cable Adjustment

1. With the throttle lever in the START (CHOKE) position, the carburetor choke arm should move all the way to UP, as far as it will go. Push the control lever with your finger to check whether it is all the way to UP.

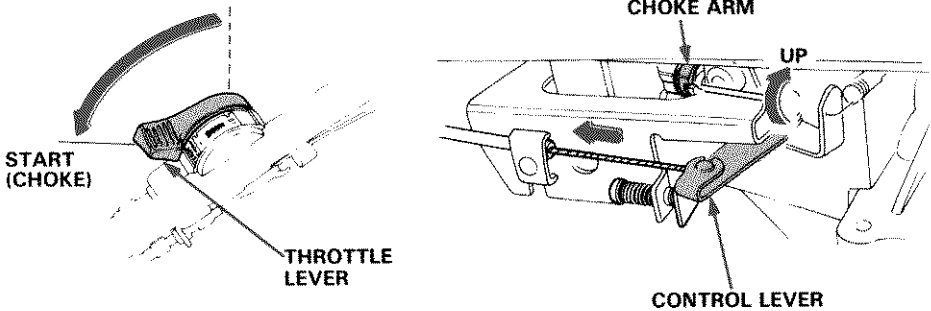

2. If adjustment is necessary, loosen the control cable lock nuts, and move the adjuster up or down as required. Tighten the lock nuts, and recheck the carburetor choke arm position.

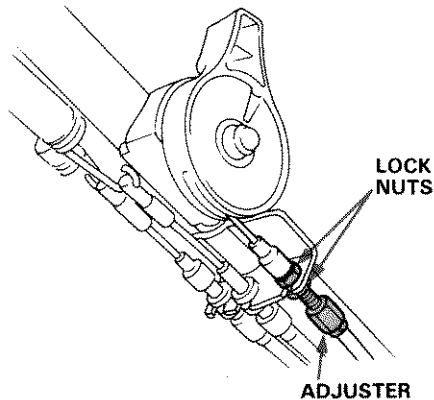

---

## Drive Clutch Free Play (Self-propelled type only)

1. Measure free play at the top of the lever as shown; it should be between 5–10 mm (3/16–3/8 in).
2. If adjustment is necessary, loosen the lock nuts and turn them to run the adjuster up or down as required. Tighten the lock nuts and recheck free play.
3. Start the engine and check to be sure the drive clutch engages and releases properly.

5–10 mm (3/16–3/8 in)

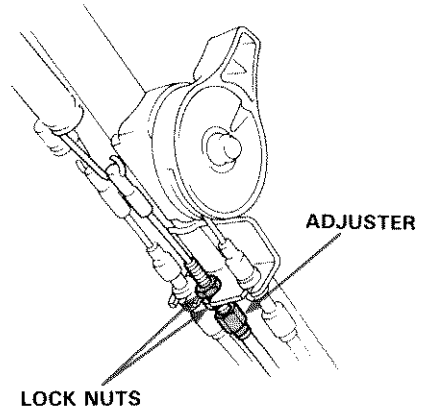
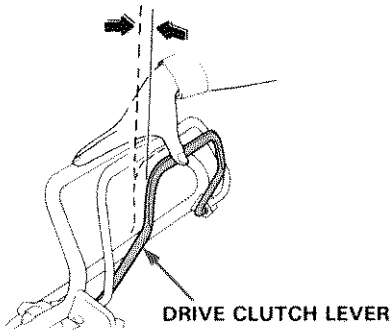

---

## Flywheel Brake Lever Free Play

1. Measure free play at the tip of the lever as shown, it should be less than 5 mm (3/16 in).
2. If adjustment is necessary, loosen the lock nuts and turn them to run the adjuster up or down as required. Tighten the lock nuts and recheck free play.
3. Start the engine and operate the brake lever. Check to be sure the engine is stopped when the lever is released.

Less than 5 mm (3/16 in)

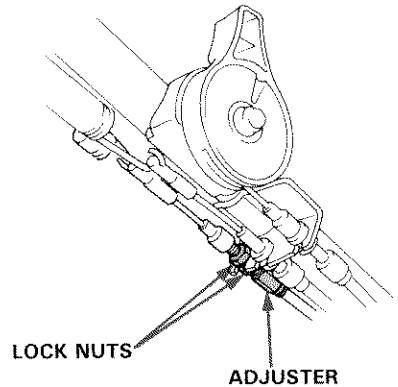
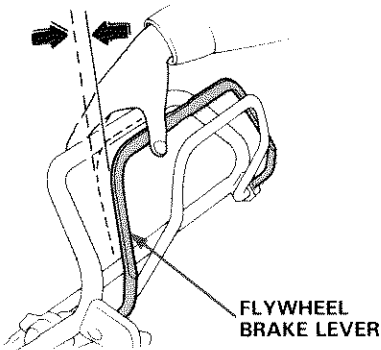

## Spark Arrester Maintenance (Optional Part)

**WARNING** If the mower has been running, the muffler will be very hot. Allow it to cool before proceeding.

1. Remove the two 4 mm screws and remove the muffler cap.
2. Remove the spark arrester and gasket from the muffler protector. (Taking care not to damage the wire mesh.)
3. Check for carbon deposits around the spark arrester, and clean if necessary.
4. Install the gasket, spark arrester and muffler cap on the muffler protector and then tighten the two 4 mm screws securely.

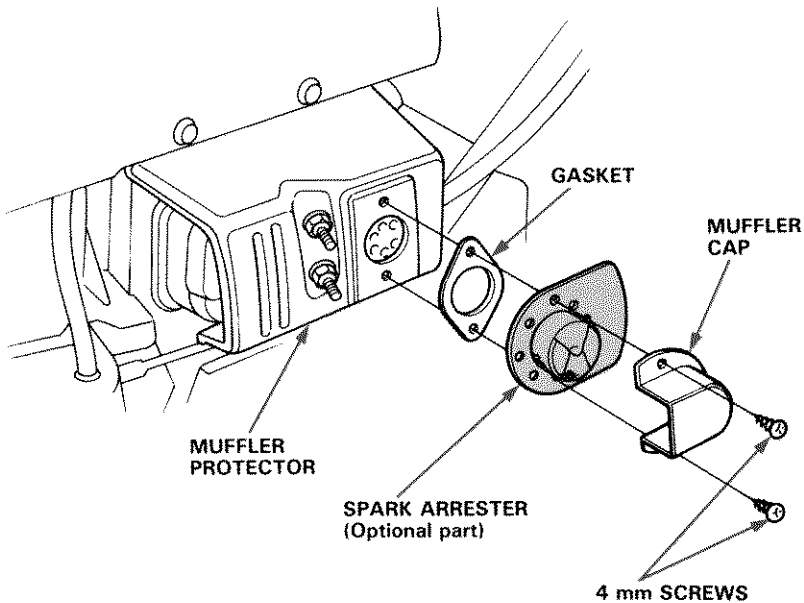

## 10. TROUBLESHOOTING

---

Engine will not start	<ol style="list-style-type: none"><li>1. No fuel.</li><li>2. Flywheel brake cable loose.</li><li>3. Spark plug wire loose or disconnected.</li><li>4. Spark plug faulty or improperly gapped (p. 30).</li><li>5. Engine flooded (p. 19).</li><li>6. Dirty air cleaner.</li></ol>
Hard starting or loss of power	<ol style="list-style-type: none"><li>1. Dirt in gas tank.</li><li>2. Dirty air cleaner.</li><li>3. Water in gas tank or carburetor.</li><li>4. Vent in gas cap and/or carburetor clogged.</li></ol>
Erratic operation	<ol style="list-style-type: none"><li>1. Spark plug faulty or improperly gapped (p. 30).</li><li>2. Dirty air cleaner.</li></ol>
Engine overheats	<ol style="list-style-type: none"><li>1. Spark plug improperly gapped.</li><li>2. Dirty air cleaner.</li><li>3. Dirty cooling fins.</li><li>4. Low oil level.</li><li>5. Flywheel clogged by grass, etc.</li></ol>
Excessive vibration	<ol style="list-style-type: none"><li>1. Loose blade or engine mounting hardware.</li><li>2. Blade unbalanced.</li></ol>

## 11. SPECIFICATIONS

MODEL	HRS21
ENGINE	GXV110
Engine type	Overhead valve, single-cylinder, forced air-cooled, four-stroke gasoline engine.
Displacement/Bore and stroke	110 cm <sup>3</sup> (6.7 cu in)/50 x 56 mm (2.0 x 2.2 in)
Ignition timing	23° BTDC
Ignition system	Transistor magneto ignition
Engine oil capacity	0.35 ℓ (0.37 US qt, 0.31 Imp qt)
Fuel tank capacity	0.8 ℓ (0.21 US gal, 0.18 Imp gal)
Spark plug	BR-4HS (NGK) or W14FR-U (ND)
FRAME Dimensions (Length x Width x Height)	SA, PA types: 1500 x 585 x 1000 mm (59.1 x 23.0 x 39.4 in) SVA, PVA types: 1500 x 735 x 1000 mm (59.1 x 28.9 x 39.4 in)
Dry weight	SA type: 34.0 kg (75.0 lb), PA type: 31.0 kg (68.4 lb) SVA type: 32.5 kg (71.7 lb), PVA type: 29.5 kg (65.0 lb)
Grass bag capacity (Grass bag-equipped type only)	55 ℓ (14.5 US gal, 12.1 Imp gal)
Cutting width	530 mm (21.0 in)

NOTE: Specifications are subject to change without notice.

## 12. WARRANTY SERVICE

---

### Owner Satisfaction

Your satisfaction and goodwill are important to your dealer and to us. All Honda warranty details are explained in the Distributor's Limited Warranty. Normally, any problems concerning the product will be handled by your dealer's service department. If you have a warranty problem that has not been handled to your satisfaction, we suggest you take the following action:

- Discuss your problem with a member of dealership management. Often complaints can be quickly resolved at that level. If the problem has already been reviewed with the Service Manager, contact the owner of the dealership or the General Manager.
- If your problem still has not been resolved to your satisfaction, contact the Power Equipment Customer Relations Department of American Honda Motor Co., Inc.

American Honda Motor Co., Inc.  
Power Equipment Customer Relations Department  
P.O. Box 50  
Gardena, California 90247-0805  
Telephone: (213) 604-2400

We will need the following information in order to assist you:

- Your name, address, and telephone number
- Product model and serial number
- Date of purchase
- Dealer name and address
- Nature of the problem

After reviewing all the facts involved, you will be advised of what action can be taken. Please bear in mind that your problem will likely be resolved at the dealership, using the dealer's facilities, equipment, and personnel, so it is very important that your initial contact be with the dealer.

Your purchase of a Honda product is greatly appreciated by both your dealer and American Honda Motor Co., Inc. We want to assist you in every way possible to assure your complete satisfaction with your purchase.

---

**MEMO**



---

**MEMO**



**HONDA**  
HONDA MOTOR CO., LTD. TOKYO. JAPAN

31VA2030  
00X31-VA2-0300

**KO**    25008903  
PRINTED IN JAPAN