

**HONDA**

**Power**

**Equipment**

**Owner's Manual**  
**Rotary Mulching Mower**  
**HRM21PVA**  
**HRM21SVA**

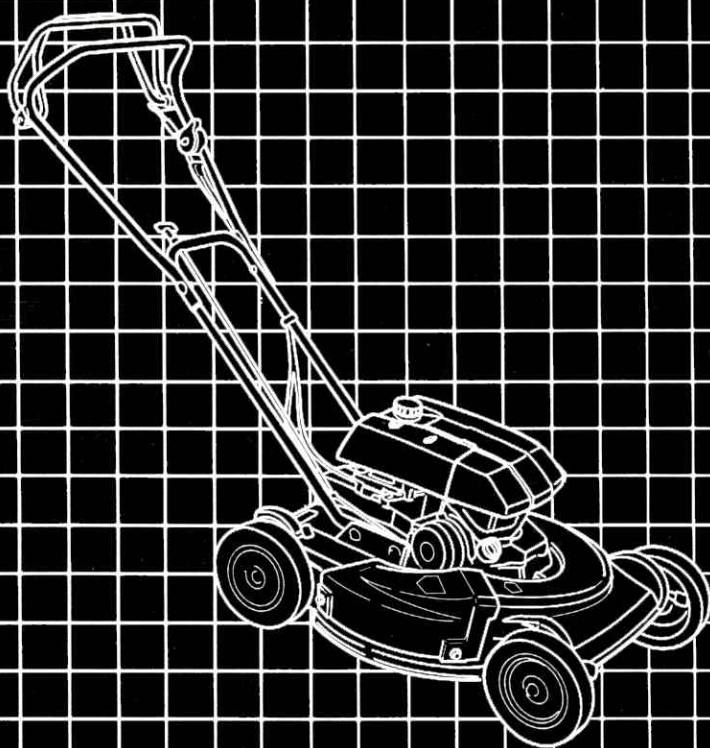

---

Thank you for purchasing a Honda rotary mulching mower.

This manual describes operation and maintenance of Honda HRM21 rotary mowers. All information in this publication is based on the latest product information available at the time of printing. Honda Power Equipment Mfg., Inc. reserves the right to make changes at any time without notice and without incurring any obligation.

No part of this publication may be reproduced without written permission.

This manual is a permanent part of the mower and must remain with the mower if resold.

Honda HRM21 mowers meet Consumer Product Safety Commission (CPSC) blade safety requirements for walk-behind rotary mowers.

Honda HRM21 mowers are not factory-equipped with spark arresters. In some areas, it is illegal to operate an engine without a USDA qualified spark arrester. Check local laws and regulations before operation. An optional spark arrester is available from authorized Honda lawn mower dealers.

**READ THIS OWNER'S MANUAL CAREFULLY.** Pay special attention to these symbols and any instructions that follow:

**▲ DANGER** Indicates serious injury or death **WILL** result if instructions are not followed.

**▲ WARNING** Indicates a strong possibility that serious injury or death may result if instructions are not followed.

**▲ CAUTION** Indicates a possibility that minor injury could result if instructions are not followed.

**NOTICE** Indicates that equipment or property damage could result if instructions are not followed.

Honda rotary mowers are designed to give safe and dependable service if operated according to instructions. Operating this mower requires special effort on your part to ensure your safety and the safety of others. Using this mower for a purpose not intended may cause injury or property damage. Use only for mowing (cutting) grass and for mulching grass and fallen leaves.

**▲ WARNING** Careless operation or misuse may cause injury or property damage. Read and understand this owner's manual before operating the mower.

If a problem should arise, or if you have any questions about your mower, see an authorized Honda lawn mower dealer.

© 1990 American Honda Motor Co., Inc. — All Rights Reserved

# CONTENTS

---

1. SAFETY . . . . .	4
Safety Label Locations . . . . .	4
Safety Information . . . . .	5
Important Message to Parents . . . . .	7
2. COMPONENT IDENTIFICATION . . . . .	8
3. BLADES AND ATTACHMENTS . . . . .	10
Low-Lift Blade (standard) . . . . .	10
High-Lift Blade (optional) . . . . .	10
Side-Discharge Adapter (optional) . . . . .	10
Grass Bag (optional) . . . . .	11
4. CONTROLS . . . . .	12
Fuel Valve . . . . .	12
Throttle Lever . . . . .	12
Flywheel Brake Lever . . . . .	13
Drive Clutch Lever (HRM21SVA) . . . . .	13
Cutting Height Adjustment Levers . . . . .	14
5. PRE-OPERATION CHECK . . . . .	15
Blade . . . . .	15
Attachments . . . . .	16
Engine Oil . . . . .	17
Fuel . . . . .	18
Air Filter . . . . .	20
Cutting Height . . . . .	21
6. OPERATION . . . . .	22
Starting the Engine . . . . .	22
Clearing a Flooded Engine . . . . .	24
Mower Operation . . . . .	25
Stopping the Engine . . . . .	27
High Altitude Operation . . . . .	28

7. MOWING AND MULCHING RECOMMENDATIONS . . . . .	29
8. TRANSPORTING . . . . .	32
9. MAINTENANCE . . . . .	33
Maintenance Schedule . . . . .	33
Engine Oil Change . . . . .	34
Air Filter Service . . . . .	35
Spark Plug Service . . . . .	36
Spark Arrester Maintenance (optional equipment) . . . . .	37
Flywheel Brake Cable Adjustment . . . . .	38
Drive Clutch Cable Adjustment (HRM21SVA) . . . . .	39
Throttle Cable and Stop Screw Adjustment . . . . .	40
Grass Bag Cleaning (optional equipment) . . . . .	41
Blade Removal and Installation . . . . .	42
10. STORAGE . . . . .	44
Preparation for Storage . . . . .	44
Storage . . . . .	47
Removal from Storage . . . . .	47
11. TROUBLESHOOTING . . . . .	48
12. SPECIFICATIONS . . . . .	50
13. WARRANTY SERVICE . . . . .	51

# 1. SAFETY

## SAFETY LABEL LOCATIONS

Read all safety instructions before operating the mower.

**FOR YOUR SAFETY**  
Read owner's manual before operation and maintenance.

**⚠ WARNING**

Objects hidden in the lawn can be thrown by the mower blade. They can hurt you or any bystander.

- Clear lawn before mowing.
- Keep people and pets away while mowing.

HONDA POWER EQUIPMENT MFG INC MADE IN U S A

**⚠ WARNING**

Gasoline is flammable. Stop engine, avoid heat, sparks, and open flame when refueling. ⓐ

**⚠ WARNING**

Operating mower with guard removed can be hazardous. You can be hurt by thrown objects or cut by the rotating blade. Do not operate with guard removed. ⓐ

**DANGER**  
KEEP HANDS and FEET AWAY



**DANGER**  
KEEP HANDS and FEET AWAY



**DANGER | KEEP HANDS and FEET AWAY**

## SAFETY INFORMATION

For your safety and the safety of others, pay special attention to these precautions:

### Operator Responsibility

- Know how to stop the engine quickly in case of emergency. Understand the use of all controls.
- Be sure that anyone who operates the lawn mower receives proper instruction. Allowing anyone, especially children, to operate the mower without proper instruction may result in serious injury.
- Wear long pants and protective footwear. Operating the mower while barefoot or wearing sandals would increase the risk of injury.
- Keep all persons and pets away from the mowing area.

### Blade Hazards

The blade is sharp, and it turns at high speed. Accidental contact can cause serious injury.

- If the mower tilts or overturns, the blade will be exposed; that will increase the risk of injury from blade contact and from thrown objects.
- Keep your hands and feet away from the mower deck while the engine is running.
- Stop the engine before adjusting cutting height or performing any inspection or maintenance.
- Wear heavy gloves to protect your hands from the blade when cleaning out the mower deck, or when inspecting or replacing the blade. Disconnect the spark plug cap to prevent any possibility of accidental starting.

### Thrown Object Hazards

Objects hit by the blade can be thrown with great force. Thrown objects may cause serious injury or property damage.

- Before mowing, clear the lawn of sticks, stones, dog bones, and other litter and loose objects. Mow only in daylight, so you can see and avoid objects in the grass.
- Before starting the mower, be sure that the mower deck cover is in place, or that the side-discharge adapter or grass bag adapter is installed.
- Release the flywheel brake lever to stop the blade before reaching areas with gravel, loose stones, or landscaping material.
- Broken pieces thrown from a worn or damaged blade can cause serious injury. Always inspect the blade before using the mower.

# 1. SAFETY

---

## Fire and Burn Hazards

Gasoline is extremely flammable, and gasoline vapor can explode. Use extreme care when handling gasoline. **KEEP OUT OF REACH OF CHILDREN.**

- Refuel in a well-ventilated area with the engine stopped. Keep flames and sparks away, and do not smoke in the area.
- Refuel carefully to avoid spilling fuel. Avoid overfilling the fuel tank (there should be no fuel in the filler neck). After refueling, tighten the filler cap securely. If any fuel is spilled, make sure the area is dry before starting the engine.
- After use, turn the fuel valve OFF, and store the mower on a level surface. Be sure the storage area is well-ventilated, and away from appliances, such as water heaters and clothes dryers.

Dry grass and leaves are flammable.

- If your mower is equipped with the optional grass bag, always empty the bag when you've finished mowing, even if it's not full. Stored lawn clippings are a fire hazard.
- Honda HRM21 mowers are not factory-equipped with spark arresters. It is illegal in some areas to operate an engine without a USDA qualified spark arrester. Check local laws and regulations. An optional spark arrester is available from authorized Honda lawn mower dealers.

The engine and exhaust system become very hot during operation and remain hot for a while after stopping. Contact with hot engine components can cause burns and may ignite some materials.

- Avoid touching a hot engine or exhaust system.
- Allow the engine to cool before performing maintenance, transporting the mower, or storing the mower indoors.

## Carbon Monoxide Poisoning Hazard

Exhaust contains poisonous carbon monoxide, a colorless and odorless gas. Breathing exhaust can cause loss of consciousness and may lead to death.

- If you run the engine in an area that is confined, or even partially enclosed, the air can become contaminated with a dangerous amount of exhaust gas. To keep exhaust gas from building up, provide adequate ventilation.

## IMPORTANT MESSAGE TO PARENTS

**YOUR CHILDREN'S SAFETY IS VERY IMPORTANT** to Honda. That's why we urge you to read this message before letting your youngster operate this lawn mower. Lawn mowers are tools, not toys. As with any equipment, bad judgments can result in serious injuries. You can help prevent accidents by making good decisions about *if, when, and how* your youngster operates this equipment.

The first question you'll need to ask is whether your youngster is capable of operating this mower safely. Remember, young people vary widely, and **AGE IS NOT THE ONLY FACTOR**.

Physically, a youngster must be **LARGE ENOUGH AND STRONG ENOUGH** to easily start the mower and control its direction. The youngster also needs enough size, strength, and coordination to comfortably reach and operate the controls.

Another, tougher question you need to ask is if your youngster has enough **MATURITY AND RESPONSIBILITY** to safely operate this mower. Does the young person think through problems and come to logical solutions? Be honest! Anyone who takes unnecessary risks and doesn't obey rules should not operate this lawn mower.

If you decide that your son or daughter can handle the mower safely, **CAREFULLY READ THE OWNER'S MANUAL** with your youngster. Make sure you both understand all instructions and warnings. Also, be sure your youngster wears sturdy shoes and other protective clothing when operating or handling the mower.

**SUPERVISION** is also very important. Walk with your youngster during the first few minutes of mowing. Even after the youngster has become confident with the mower, do not let the young person use the mower without good adult supervision. An adult should also be present during refueling and maintenance. In fact, it's up to parents to make sure that the mower is properly maintained and kept in safe operating condition.

By always placing safety first, your youngster will acquire useful skills and a sense of accomplishment. And you'll both get the best results from your lawn mower.



## 2. COMPONENT IDENTIFICATION

---

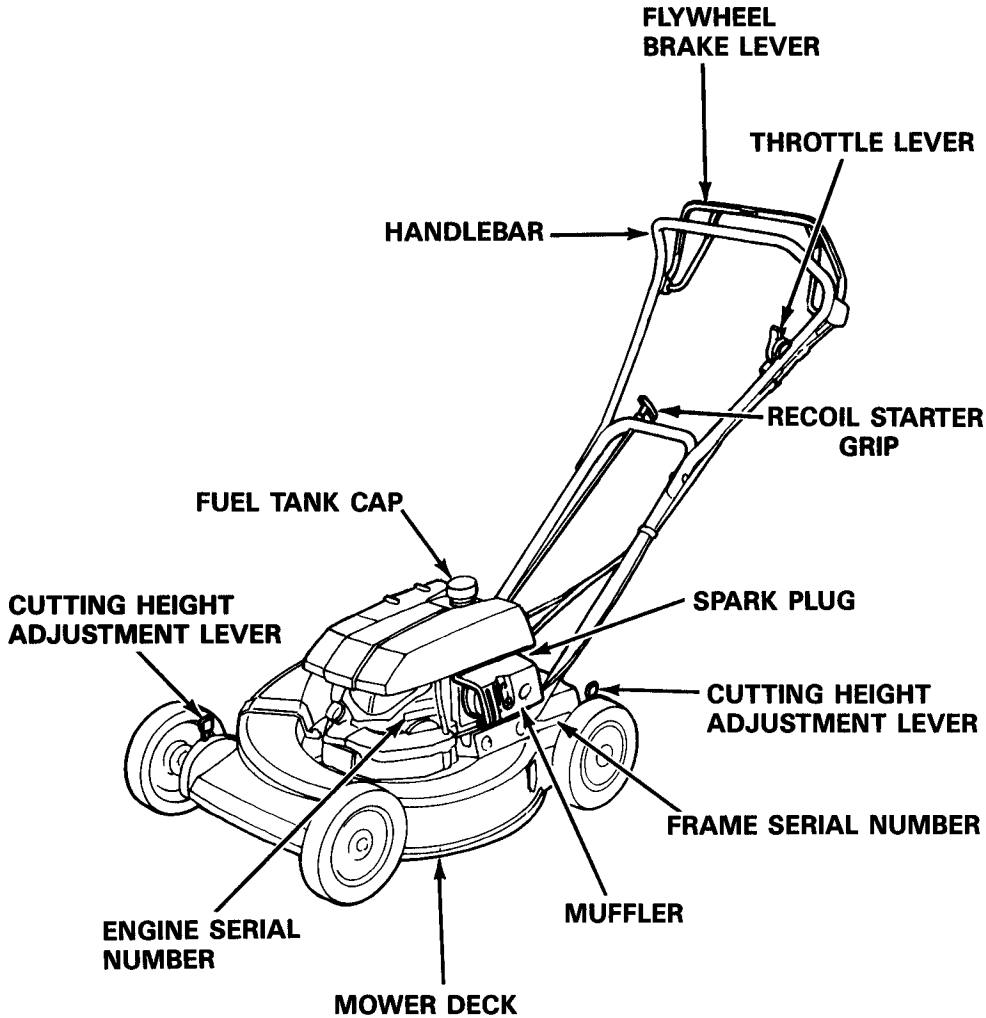

Record the frame and engine serial numbers for your reference. Refer to the serial numbers when ordering parts, and when making technical or warranty inquiries (see page 51).

Frame serial number: \_\_\_\_\_

Engine serial number: GXV110- \_\_\_\_\_

## 2. COMPONENT IDENTIFICATION

---

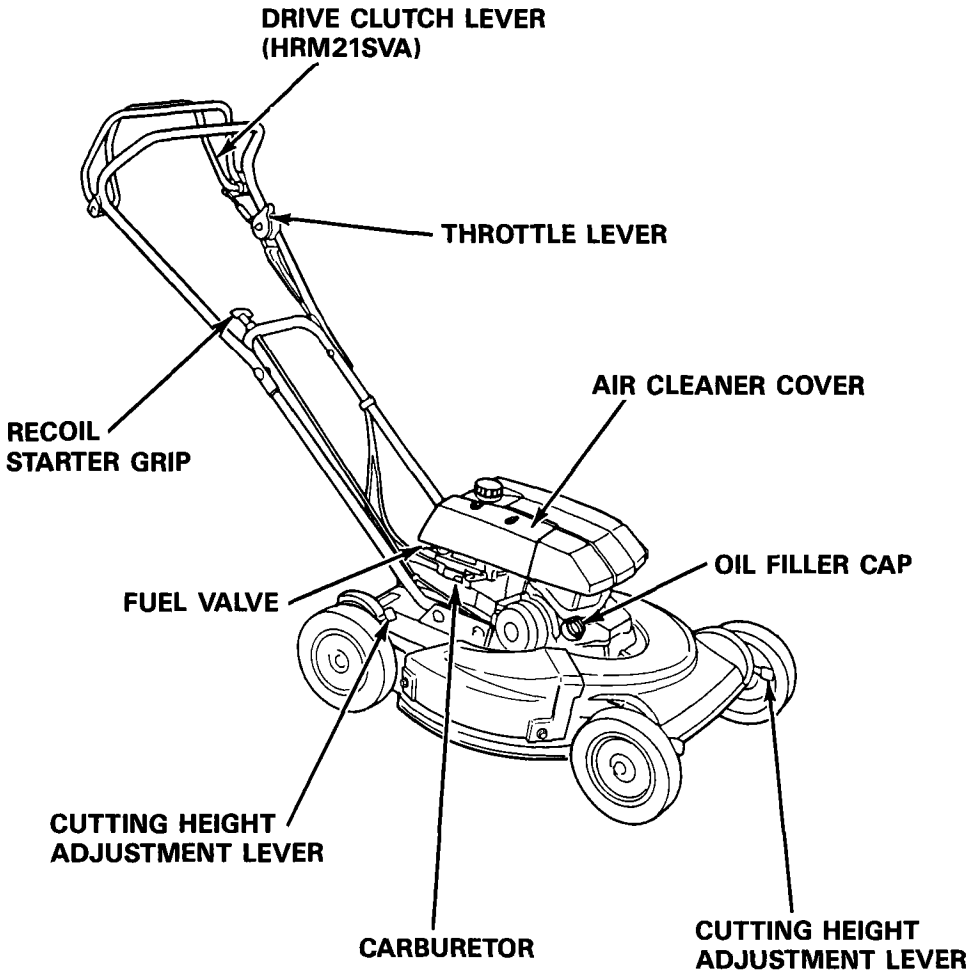

HRM21PVA: Manually propelled model

HRM21SVA: Self-propelled model

### 3. BLADES AND ATTACHMENTS

Honda HRM21 mulching mowers are factory-equipped with a low-lift blade and mower deck cover designed to cut grass clippings and fallen leaves into fine particles that will fall through the turf and decompose quickly. This returns nutrients to the soil and reduces the need for raking, bagging, and disposal.

A side-discharge kit and a grass bag kit are available as optional equipment. Side-discharging mowing, or bagging, should be considered where grass has grown too tall to mulch easily. Bagging should also be considered for areas where you want the lawn to be clear of loose particles, such as around swimming pools.

The side-discharge adapter, or grass bag adapter, bolts onto the mower deck in place of the standard deck cover. Refer to the installation instructions supplied with these kits. For side-discharge mowing, or bagging, be sure to install the optional high-lift blade.

#### LOW-LIFT HRM21 BLADE (standard) FOR MULCHING



The low-lift blade recirculates cut grass under the mower deck, where it is chopped and shredded into small particles.

#### HIGH-LIFT HRM21 BLADE (optional) FOR SIDE-DISCHARGE MOWING OR BAGGING



The high-lift blade blows cut grass out the discharge chute or into the bag.

#### SIDE-DISCHARGE ADAPTER (optional)

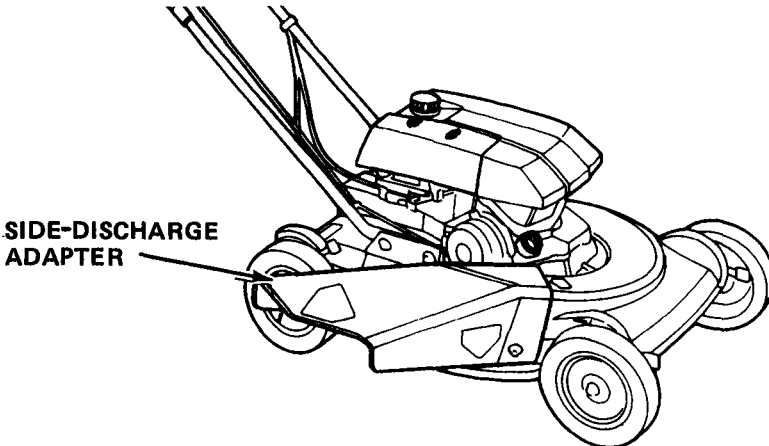

# 3. BLADES AND ATTACHMENTS

## GRASS BAG (optional)

### Installation

1. Close the grass bag zipper.
2. Hook the rear bag handle on the handlebar hook.
3. Open the discharge guard, and hook the mouth of the grass bag onto the mower deck.
4. Release the discharge guard.

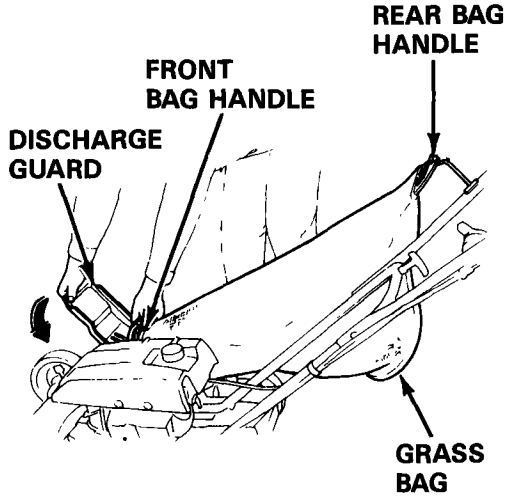

### Removal

1. Raise the discharge guard.
2. Grasp the front bag handle, and raise the mouth of the bag to remove it from the mower deck.
3. Release the discharge guard.
4. Unhook the rear bag handle, and remove the bag.



### Emptying

- Open the zipper to empty the bag.

## 4. CONTROLS

### FUEL VALVE

The fuel valve opens and closes the connection between the fuel tank and the carburetor.

The fuel valve must be in the ON position for the engine to run.

When the mower is not in use, turn the fuel valve to the OFF position to prevent the possibility of carburetor flooding, and to reduce the possibility of fuel leakage.

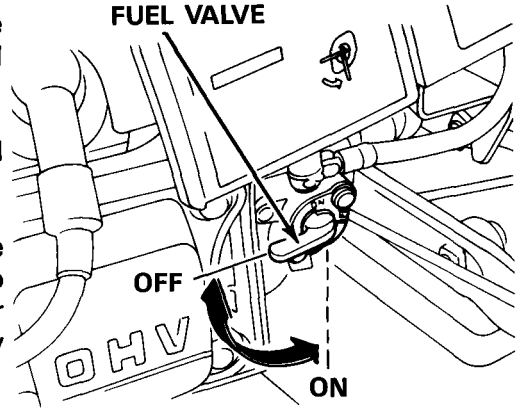

**⚠ WARNING** Gasoline is extremely flammable, and gasoline vapor can explode. Turn the fuel valve to the OFF position when the mower is not in use.

### THROTTLE LEVER

START (CHOKE) position: For starting

HI position: For mowing and mulching

LO position: For idling

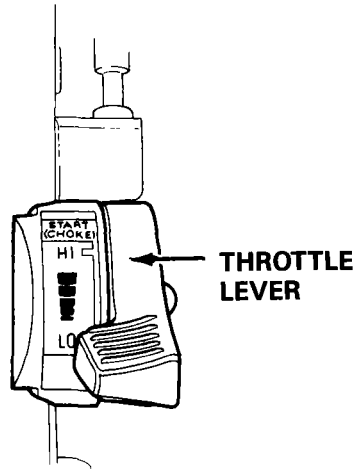

### FLYWHEEL BRAKE LEVER (all models)

This lever is connected to the engine flywheel brake and the ignition system. The engine will not start or run unless this lever is pushed forward.

To start the engine and blade, push the lever forward and hold it against the handlebar while operating the recoil starter. Continue to hold the lever against the handlebar while mowing and mulching.

To stop the engine and blade, release the lever.

FLYWHEEL BRAKE LEVER

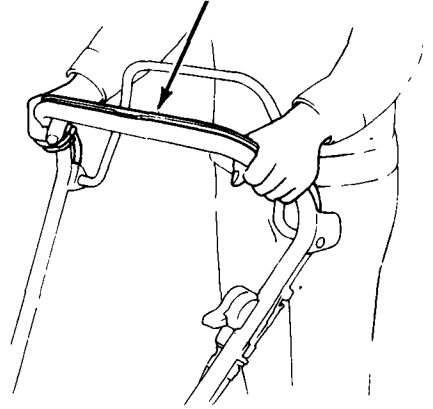

### DRIVE CLUTCH LEVER (HRM21SVA only)

This lever operates the drive clutch for the rear wheels.

Maximum drive speed at full throttle is 3.3 feet per second (1.0 meter per second).

For self-propelled operation, push the drive clutch lever forward, and hold it against the handlebar together with the flywheel brake lever. Release the lever to disengage the drive.

Always release the drive clutch lever before starting the engine. If the drive clutch lever is held forward while starting, the mower will move forward before you are ready to guide it.

DRIVE CLUTCH LEVER  
(HRM21SVA ONLY)

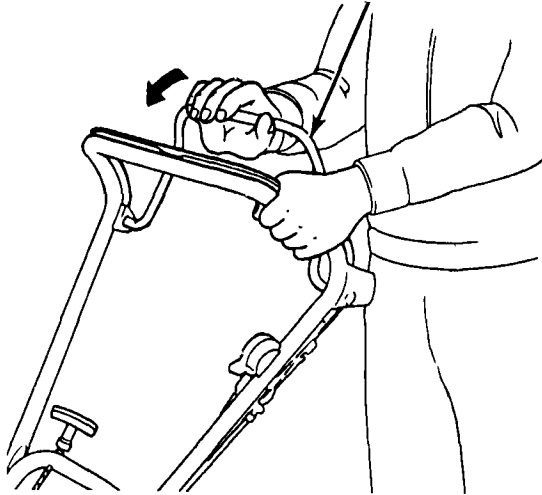

# 4. CONTROLS

## CUTTING HEIGHT ADJUSTMENT LEVERS

**▲WARNING** The blade can cause serious injury. Stop the engine before adjusting cutting height.

There are six cutting height settings: 3/4 in, 1-1/4 in, 1-3/4 in, 2-1/4 in, 2-5/8 in, and 3 in. These are approximate figures, as the actual height of cut grass will vary with lawn and soil conditions.

To adjust cutting height, pull each adjustment lever toward the wheel, and move it into another notch. Set all four adjustment levers to the same cutting height position.

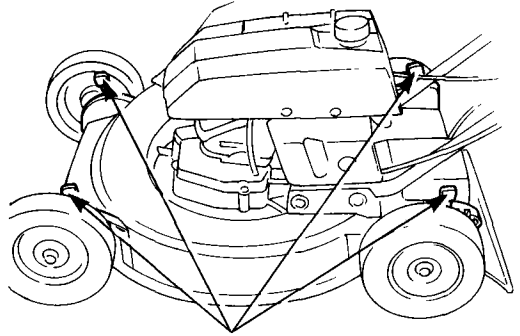

ADJUSTMENT LEVERS

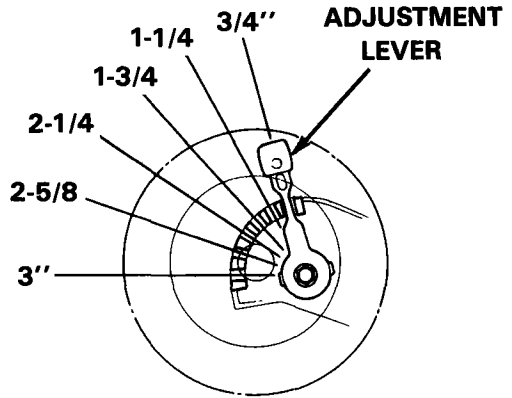
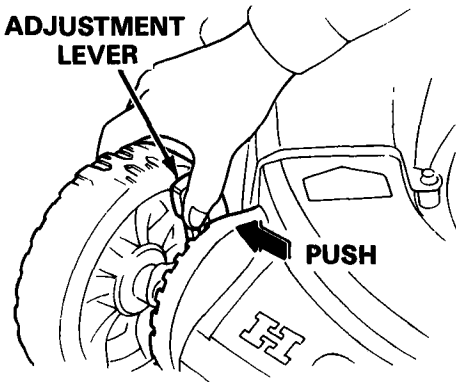

Select the correct cutting height for your mowing requirements. Cutting height settings of 1-1/4 to 2-1/4 inches are appropriate for most lawns during cool weather. A higher cut may be needed to protect the lawn during hot summer months. Consult a local nursery or lawn and garden center for advice about specific types of grasses and growing conditions in your area.

If you are not certain which cutting height to select, check the appearance of the lawn after mowing a small area, then readjust cutting height if necessary.

## 5. PRE-OPERATION CHECK

Check the following items before starting the engine.

### BLADE

Turn the fuel valve OFF, and tilt the mower to the left, so the carburetor side is up.

**NOTE:** Hard starting and fuel leakage may result if the mower is tilted with the carburetor side down.

Inspect the blade for wear and damage.

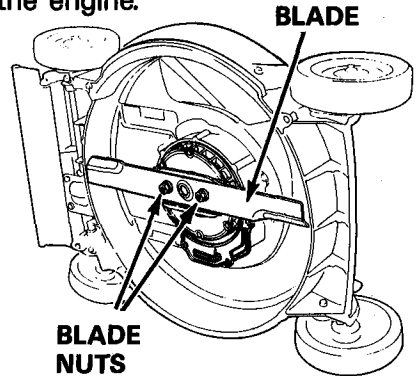

**NORMAL**



**EXCESSIVELY  
WORN**



**BENT**



**CRACKED**

A dull blade can be sharpened, but a blade that is worn out, bent, cracked, or otherwise damaged must be replaced. A worn or damaged blade could break causing pieces of the blade to be thrown from the mower.

**▲WARNING** A worn or damaged blade can cause serious injury. Always inspect the blade before using the mower.

When the blade needs sharpening or replacement, take the lawn mower to an authorized Honda lawn mower dealer. Or, if you have a torque wrench, you can remove and install the blade yourself (see page 42).

- **Blade sharpening:** To avoid weakening the blade, or causing imbalance or poor cutting, the blade should be sharpened by an authorized Honda lawn mower dealer.
- **Blade replacement:** Use a genuine Honda replacement blade or its equivalent. Use a low-lift blade (p. 10) for mulching. Use a high-lift blade (p. 10) for side-discharge mowing or bagging.

Check that the blade nuts are tight. Use a wooden block to prevent the blade from turning when tightening the nuts. Wear heavy gloves to protect your hands. Blade nut torque: 36.2–43.4 ft-lb (5.0–6.0 kg-m).



## 5. PRE-OPERATION CHECK

---

### ATTACHMENTS

#### Side-Discharge Adapter (optional)

Check the side-discharge adapter to be sure it is in good condition and properly attached. Operating the mower with a damaged or loose side-discharge adapter will increase risk of injury from objects thrown by the blade.

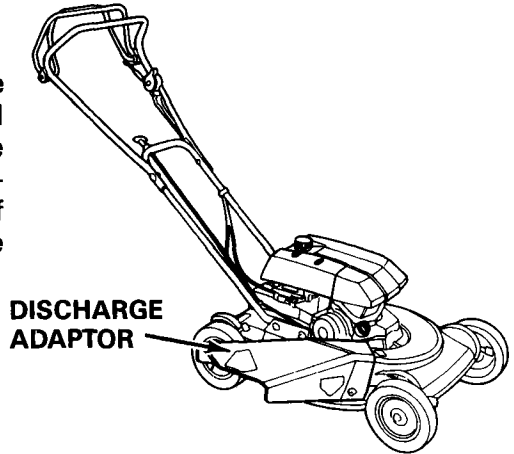

#### Grass Bag (optional)

Check that the grass bag is in good condition and not clogged.

A clogged grass bag will not collect grass efficiently. When the bag needs cleaning, wash it with a garden hose, and allow it to dry thoroughly before use; a wet bag will clog quickly.

The grass bag wears during normal use and will eventually need replacement. If you operate the mower with a damaged or worn out bag, objects picked up by the blade may be thrown through the bag material.

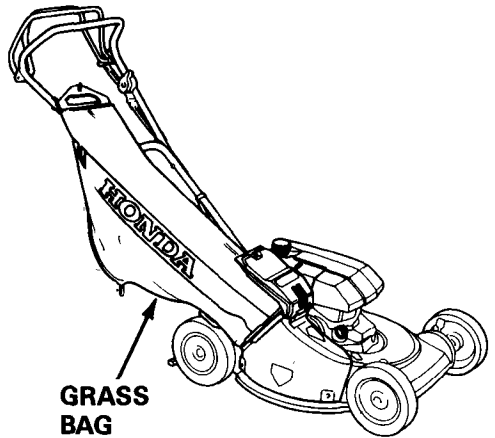

## 5. PRE-OPERATION CHECK

### ENGINE OIL

Check the engine oil level with the engine stopped and the mower on a level surface.

1. Remove the oil filler cap, and wipe the dipstick clean.
2. Insert and remove the dipstick without screwing it into the filler neck. Check the oil level shown on the dipstick.
3. If the oil level is low (near the bottom of the dipstick), fill to the top of the oil filler neck with the recommended oil.

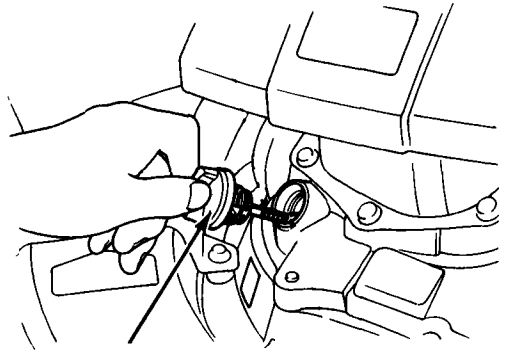

FILLER CAP/  
DIPSTICK

**NOTICE** Running the engine with a low oil level will cause engine damage.

Use high-detergent, premium quality 4-stroke engine oil, certified to meet or exceed U.S. automobile manufacturers' requirements for API Service Classification SG, SF/CC, CD.

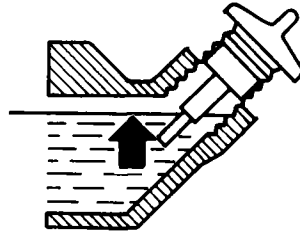

**NOTICE** Using nondetergent oil can shorten the engine's service life, and using 2-stroke oil will damage the engine.

SAE 10W-30 is recommended for general, all-temperature use. Other viscosities shown in the chart may be used when the average temperature in your area is within the indicated range.

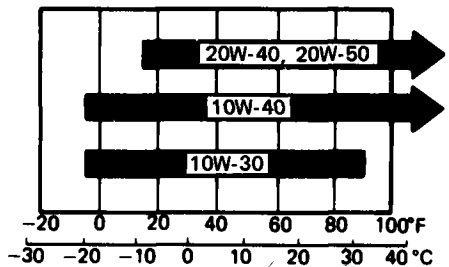

## 5. PRE-OPERATION CHECK

---

### FUEL

Fuel tank capacity: 0.21 US gal (0.8 ℓ)

Remove the tank cap and check the fuel level. Refill the tank if the fuel level is low. Refuel carefully to avoid overfilling or spilling fuel. There should be no fuel in the filler neck.

**▲WARNING** Gasoline is extremely flammable, and gasoline vapor can explode. Use extreme care when handling gasoline.

Refuel in a well-ventilated area with the engine stopped. Do not smoke or allow flames or sparks in the area where the engine is refueled or where gasoline is stored. Avoid repeated or prolonged contact with skin or breathing of vapor.

After refueling, tighten the fuel tank cap securely. If any fuel was spilled, make sure the area is dry before starting the engine.

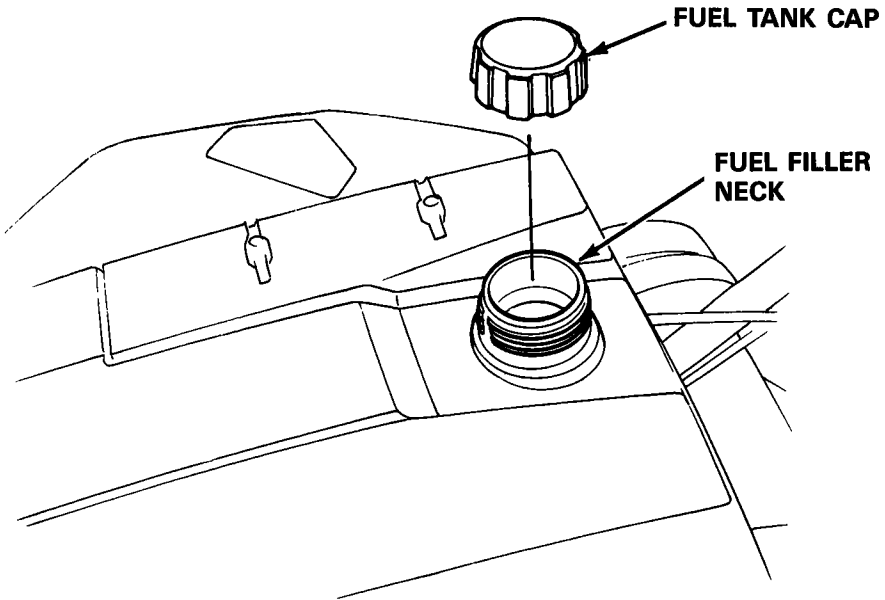

## 5. PRE-OPERATION CHECK

Fuel	Recommendation
<b>Pump octane rating: 86 or higher.</b>	

We recommend unleaded fuel because it produces fewer engine and spark plug deposits and extends exhaust system life.

Never use stale or contaminated gasoline or an oil/gasoline mixture. Avoid getting dirt or water in the fuel tank.

Occasionally you may hear light "spark knock" or "pinging" (metallic rapping noise) while operating under heavy loads. This is no cause for concern.

If spark knock or pinging occurs at a steady engine speed, under normal load, change brands of gasoline. If spark knock or pinging persists, see an authorized Honda lawn mower dealer.

**NOTICE** Running the engine with persistent spark knock or pinging can cause engine damage.

NOTE: Running the engine with persistent spark knock or pinging is considered misuse, and the Distributor's Limited Warranty does not cover parts damaged by misuse.

### Gasolines Containing Alcohol

If you decide to use a gasoline containing alcohol (gasohol), be sure its octane rating is at least as high as that recommended by Honda. There are two types of "gasohol": one containing ethanol, and the other containing methanol. Do not use gasohol that contains more than 10% ethanol. Do not use gasoline containing methanol (methyl or wood alcohol) that does not also contain cosolvents and corrosion inhibitors for methanol. Never use gasoline containing more than 5% methanol, even if it has cosolvents and corrosion inhibitors.

NOTE:

- Fuel system damage or engine performance problems resulting from the use of fuels that contain alcohol are not covered under the warranty. Honda cannot endorse the use of fuels containing methanol since evidence of their suitability is as yet incomplete.
- Before buying fuel from an unfamiliar station, try to find out if the fuel contains alcohol. If it does, confirm the type and percentage of alcohol used. If you notice any undesirable operating symptoms while using a gasoline that contains alcohol, or one that you think contains alcohol, switch to a gasoline that you know does not contain alcohol.

## 5. PRE-OPERATION CHECK

---

### AIR FILTER

Check that the air filter is clean and in good condition. A dirty air filter will restrict air flow to the carburetor, reducing engine performance. A damaged air filter will allow dirt to enter to engine, causing rapid engine wear.

1. Remove the wing nuts, then remove the air cleaner cover.
2. Inspect the filter. Replace the filter if it is damaged. Clean or replace the filter if it is dirty.

To clean the air filter, tap it several times on a hard surface to remove dirt, or blow compressed air (not exceeding 30 psi) through the filter from the inside. Never try to brush off dirt; brushing will force dirt into the filter fibers.

If the air cleaner housing and cover are dirty, wipe them clean with a moist rag. Be careful to avoid dropping dirt into the air duct that leads to the carburetor.

3. Reinstall the air filter and air cleaner cover. Tighten the wing nuts securely.

**NOTICE** Operating the engine with no air filter, or a damaged air filter, can cause rapid engine wear.

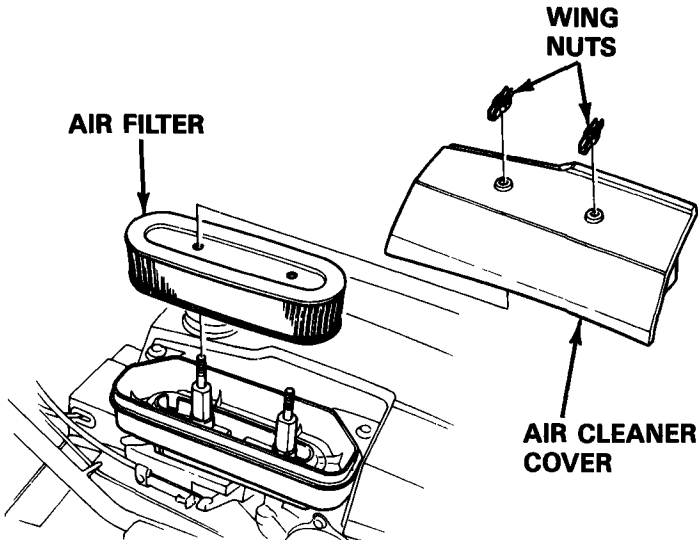

## 5. PRE-OPERATION CHECK

### CUTTING HEIGHT

Check the cutting height settings, and make any necessary adjustments (see page 14). Set all four adjustment levers to the same cutting height position.

**▲WARNING** The blade can cause serious injury. Stop the engine before adjusting cutting height.

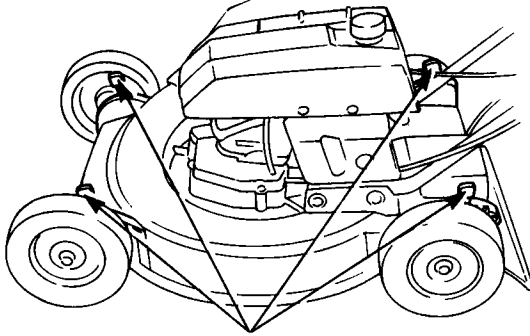

**ADJUSTMENT LEVERS**

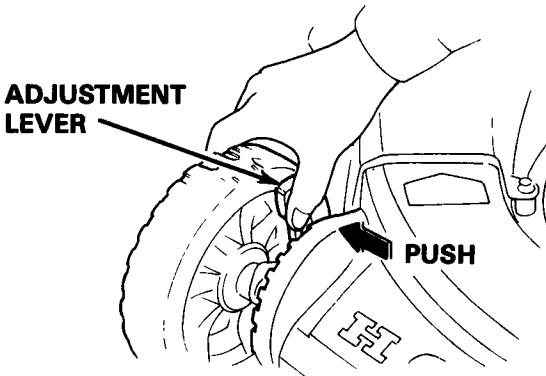

## 6. OPERATION

### STARTING THE ENGINE

Start the engine outdoors. If you run the engine in an area that is confined, or even partially enclosed, the air can become contaminated with a dangerous amount of exhaust gas.

#### **WARNING**

Exhaust contains poisonous carbon monoxide, a colorless and odorless gas. Breathing exhaust can cause loss of consciousness and may lead to death. To keep exhaust gas from building up, provide adequate ventilation.

1. Turn the fuel valve to the ON position.
2. FOR STARTING A COLD ENGINE:  
Move the throttle lever to the START (CHOKE) position.

FOR RESTARTING A WARM ENGINE: Move the throttle lever to the HI position.

3. Push the flywheel brake lever forward and hold it against the handlebar.

**NOTE: HRM21SVA ONLY** — Release the drive clutch lever before starting the engine. If the drive clutch lever is held forward while starting, the mower will move forward before you are ready to guide it.

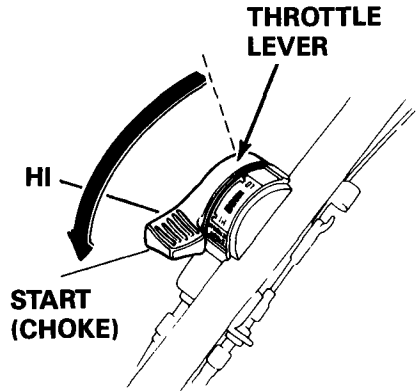
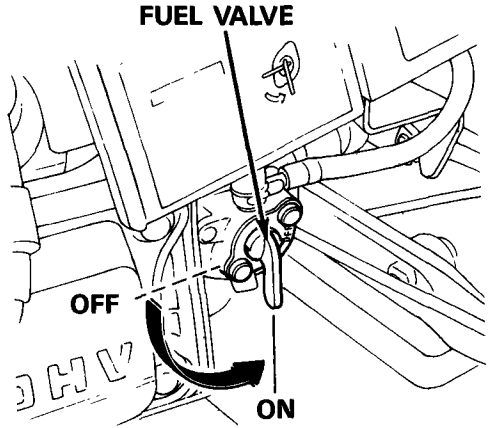

**FLYWHEEL BRAKE LEVER**

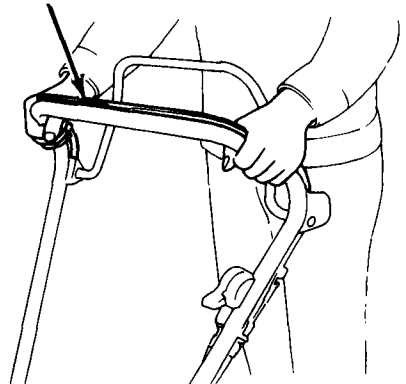

4. Pull the starter grip lightly until you feel resistance, then pull briskly. Return the starter rope gently; don't let it snap back against the handlebar.

Continue to hold the flywheel brake lever forward against the handlebar when the engine starts. The engine will stop if you release the lever.

**NOTE:** The blade turns when you operate the starter. It is easiest to start the engine in a clear or mowed area where the blade can turn freely.

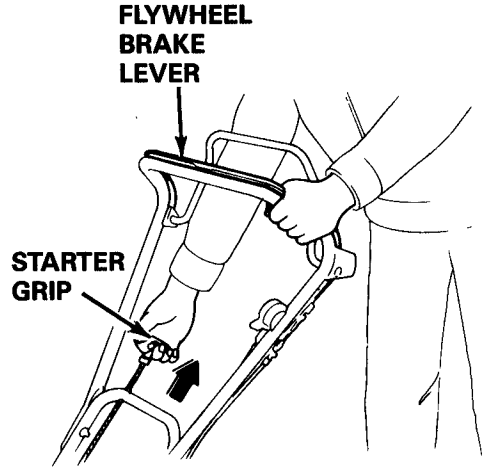

5. When the engine warms up, move the throttle lever away from the START (CHOKE) position. Set the lever in the HI position for mowing and mulching, or in the LO position for idling.

**NOTE:** If restarting a warm engine in the START (CHOKE) position, move the throttle lever away from START (CHOKE) as soon as the engine starts.

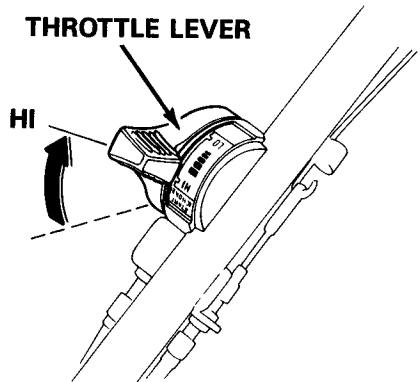



## 6. OPERATION

---

### CLEARING A FLOODED ENGINE

If the engine won't start after you have operated the starter several times, the engine may be flooded with excess fuel. Use the following procedure to clear and start a flooded engine:

#### 13/16 INCH SPARK PLUG WRENCH

1. Remove the spark plug, dry it, then reinstall it.

**NOTE:** Install the spark plug carefully, by hand, to avoid cross-threading. After the spark plug is seated, tighten 1/8 to 1/4 turn with a spark plug wrench to compress the washer.

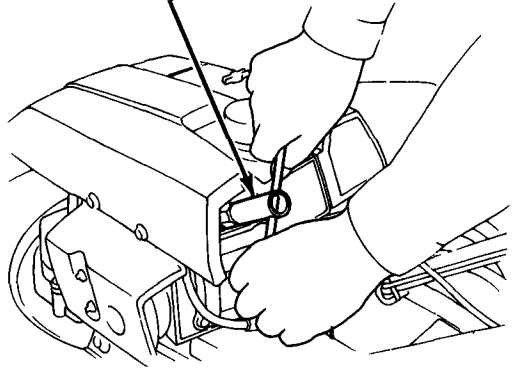

2. Move the throttle lever to the HI position.

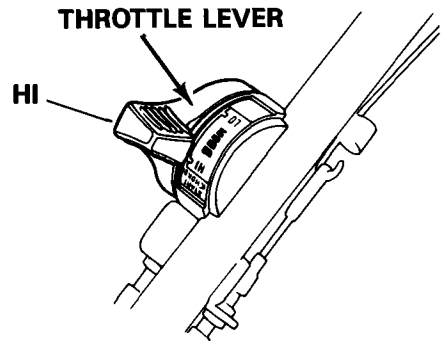

3. Hold the flywheel brake lever forward against the handlebar, and operate the starter with the throttle lever in the HI position.

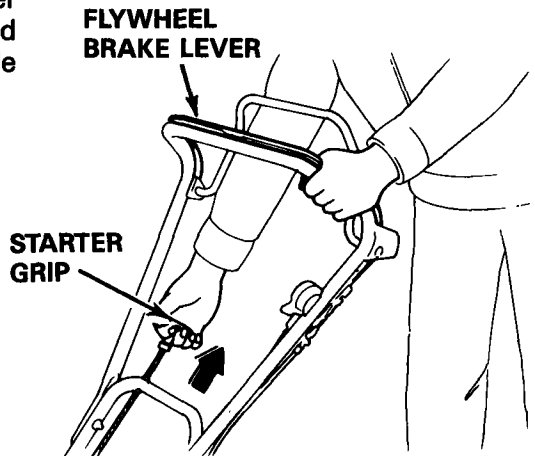

## MOWER OPERATION

For best grass cutting, mulching, or bagging performance, and to avoid stalling the engine, always mow with the throttle lever in the HI position.

For self-propelled operation (HRM21SVA), push the drive clutch lever forward, and hold it against the handlebar together with the flywheel brake lever.

Release the drive clutch lever to disengage the drive when mowing around trees and other obstacles. Push the mower for better directional control.

Release the flywheel brake lever to stop the engine and blade before reaching areas with gravel, loose stones, or landscaping material. Objects hit by the blade can be thrown with great force.

**▲WARNING** Thrown objects may cause serious injury and property damage. Stop the blade before reaching any area with loose objects.

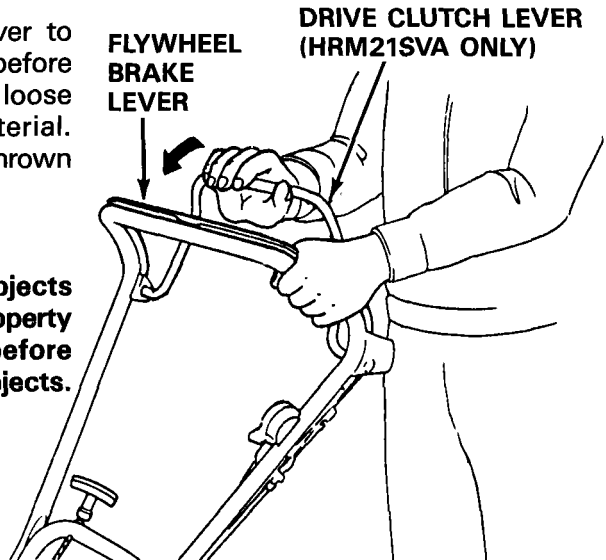
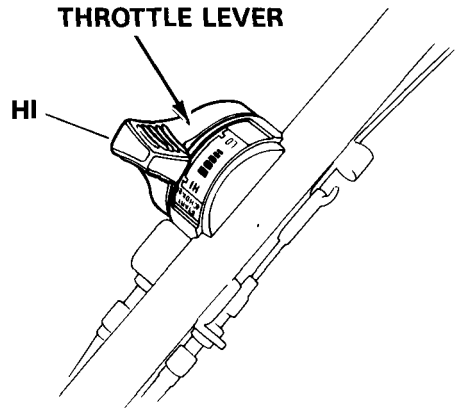

## 6. OPERATION

---

For your safety, keep all four wheels on the ground, and be careful not to lose your footing and your control of the mower. Keep a firm grip on the handlebar, and walk, never run, with the mower. Be very careful when mowing uneven or rough ground.

Mow across slopes, never up and down. Be careful when changing the direction of the mower on a slope. Do not use the mower on a steep slope of more than 20°.

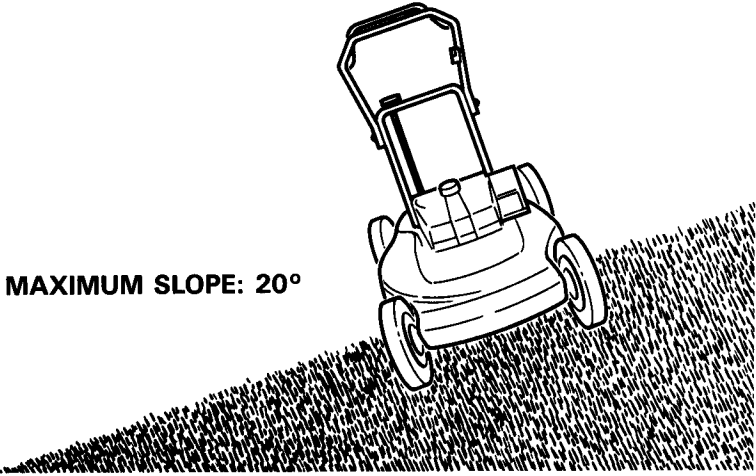

Use extra care when mowing over objects imbedded in the lawn, such as sprinkler heads, paving, edging, etc. Avoid anything that sticks up above the surface of the lawn. Striking objects may damage the blade, bend the crankshaft, and/or break the mower deck or other components.

### **▲WARNING**

**A damaged blade may break. Broken pieces can be thrown by the blade and may cause serious injury. Stop the engine immediately if you suspect the blade is damaged.**

If the blade hits something, or if the mower starts to vibrate, follow these steps:

1. Stop the engine.
2. Inspect the blade and other mower components for damage.
3. Replace any damaged parts before operating the mower.

**NOTE:** The Distributor's Limited Warranty does not cover parts damaged by accident or collision.

## STOPPING THE ENGINE

Release the flywheel brake lever to stop the engine.

When the mower is not in use, turn the fuel valve to the OFF position to prevent the possibility of carburetor flooding, and to reduce the possibility of fuel leakage.

**⚠WARNING** Gasoline is extremely flammable, and gasoline vapor can explode. Turn the fuel valve to the OFF position when the mower is not in use.

FLYWHEEL BRAKE LEVER

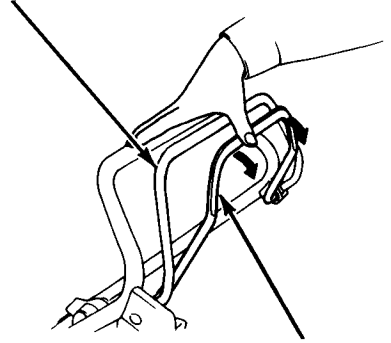

DRIVE CLUTCH LEVER  
(HRM21SVA ONLY)

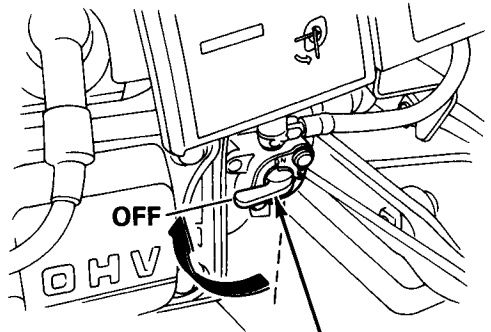

FUEL VALVE

## **6. OPERATION**

---

### **HIGH ALTITUDE OPERATION**

At high altitude, the standard carburetor air-fuel mixture will be too rich. Performance will decrease, and fuel consumption will increase. A very rich mixture may also foul the spark plug and cause hard starting.

High altitude performance can be improved by installing a smaller diameter main fuel jet in the carburetor and readjusting the pilot screw. If you always operate the mower at altitudes higher than 6,000 feet above sea level, have an authorized Honda lawn mower dealer perform this carburetor modification.

Even with carburetor modification, engine horsepower will decrease about 3.5% for each 1,000 foot increase in altitude. The effect of altitude on horsepower will be greater than this if no carburetor modification is made. A reduction in engine horsepower will reduce mowing performance.

When the carburetor is modified for good high altitude operation, the air/fuel mixture will be too lean at low altitude. Performance will decrease, and the engine will overheat.

To avoid an excessively lean air/fuel mixture and engine damage, reinstall the standard main fuel jet and readjust the pilot screw for operation at altitudes lower than 6,000 feet above sea level.

## **7. MOWING AND MULCHING RECOMMENDATIONS**

---

Cutting height settings of 1-1/4 to 2-1/4 inches are appropriate for most lawns during cool weather. A higher cut may be needed to protect the lawn during hot summer months. Consult a local nursery or lawn and garden center for advice about specific types of grasses and growing conditions in your area.

Most grasses should be mowed when they have grown 1/2 to 1 inch above the recommended height. For the best mulching results, mow the lawn frequently enough that you will need to cut off less than one inch.

Frequent mowing, with light cuts, makes it easier for your mulching mower to turn the grass clippings into fine particles that will fall through the turf and decompose quickly.

Long clippings from tall grass cannot be easily reduced to fine particles. Also, if allowed to grow too tall, and then cut back to the stems, the grass may not recover well, and the lawn will have brown patches.

As a general rule, do not cut off more than a third of the total height of the grass in one mowing. If tall grass is reduced in height a little at a time, and is allowed to recover between mowings, the grass will be healthier, and the mower will work better and will leave a better lawn finish.

For good mowing conditions, the grass should be relatively dry, but the ground should not be so dry that the mower stirs up a lot of dust. Besides being unpleasant to work in, too much dust will clog the carburetor air filter, reducing engine performance.

If dust is a problem, water your lawn the day before mowing, allowing the grass to dry while the soil remains moist.

Always wait for wet grass to dry. Wet grass will clog the mower deck, it will leave clumps on top of the lawn, and if you use the optional grass bag, it will not bag well either.

If clogging or clumping occurs under normal conditions, mow more frequently, cut a narrower swath, and/or push the mower more slowly. You may also need to raise the mower's cutting height. Heavy clumps of clippings should always be removed from the lawn; grass must remain uncovered to grow properly.

If you must clean out a clogged mower deck, turn the fuel valve OFF, and tilt the mower so the carburetor side is up. Hard starting and fuel leakage may result if the mower is tilted with the carburetor side down.

# 7. MOWING AND MULCHING RECOMMENDATIONS

## MOWING PATTERNS

Your Honda HRM21 mower will work most efficiently if you use the following mowing patterns as much as possible. Mower deck and equipment design, and the direction in which the blade rotates, cause these mowing patterns to give the best results.

### Mulching (standard equipment):

Use a counterclockwise mowing pattern. If the lawn has an irregular shape, or many obstacles, divide it into sections where you can use counterclockwise mowing patterns.

### Side-discharge mowing (optional equipment):

Use a counterclockwise mowing pattern, starting at the outer edges of the lawn and working toward the center. This will prevent clippings from piling up in the path of the mower.

### Bagging (optional equipment):

Use a clockwise mowing pattern, starting at the outer edges of the lawn and working toward the center. This will give the best bagging performance, leaving the least amount of clippings on the lawn.

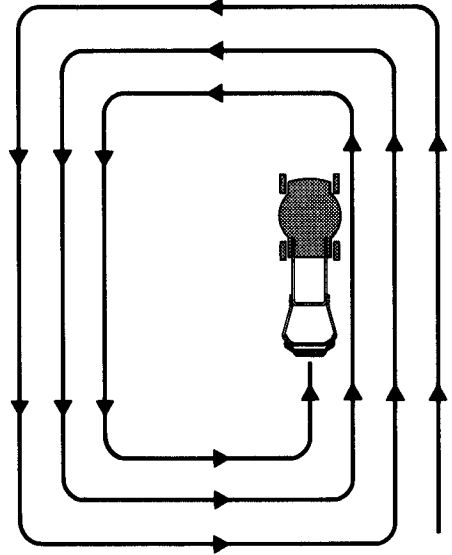

**RECOMMENDED MOWING PATTERN FOR MULCHING AND FOR SIDE-DISCHARGE MOWING**

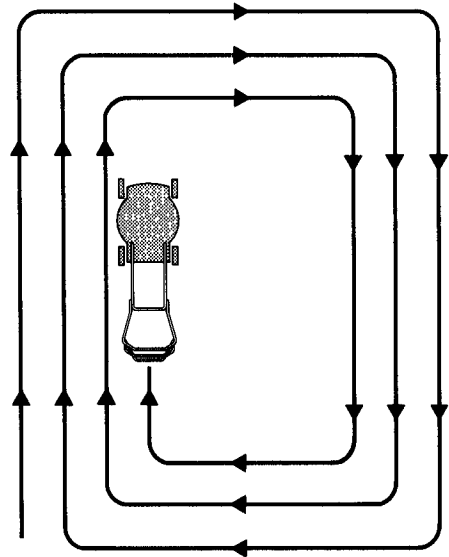

**RECOMMENDED MOWING PATTERN FOR BAGGING**

## 7. MOWING AND MULCHING RECOMMENDATIONS

---

Always empty the grass bag before it becomes filled to the limit of its capacity. Bagging performance will diminish after the bag becomes about 90% filled. Also, the bag is easier to empty when it is not packed full.

Always empty the grass bag when you have finished mowing, even if it is not full. Stored lawn clippings are a fire hazard.

A clogged grass bag will not collect grass efficiently. If the bag becomes clogged with dirt, wash it with a garden hose, and allow it to dry completely before use; a wet bag will clog quickly.



If the grass is not very thick or tall, you can mow a wide swath. Keep the wheels close to the swath line for maximum cutting width.

If the grass is very thick or tall, cutting a wide swath may slow or stall the engine, clog the mower deck, and cause poor mulching or bagging performance. For thick or tall grass, cut a narrower swath, and/or push the mower more slowly. If necessary, mow twice; first with a high cut, then at final cutting height.

For best performance, the blade must spin very fast. Always use the HI throttle setting when mowing, and keep the engine running at or near maximum rpm. If you hear engine speed decrease, that means you should mow a narrower swath, and/or push the mower more slowly. You may also need to raise the mower's cutting height.



## 8. TRANSPORTING

---

**CAUTION** The engine and exhaust system become hot during operation and remain hot for a while after stopping. Contact with hot engine components can cause burns and can ignite some materials.

Avoid touching the engine or exhaust system for at least 15 minutes after the engine has stopped. Allow the engine to cool before transporting the mower.

### Before Loading

- Turn the fuel valve to the OFF position. This will prevent the possibility of carburetor flooding and will reduce the possibility of fuel leakage.
- Remove the grass bag, if so equipped.

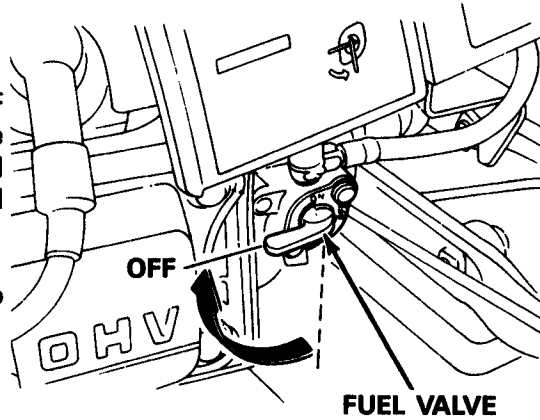

### Loading/Unloading

To reduce the possibility of fuel leakage, keep the mower level while transporting, and avoid tilting the mower excessively when loading and unloading.

- If a suitable loading ramp is not available, two people should lift the mower on and off the vehicle, while holding the mower level.
- Position the mower so all 4 wheels are on the bed of the vehicle. Tie the mower down with rope or straps, and block the wheels. Keep the tie-down rope or straps away from controls, adjustment levers, cables, carburetor, and the fuel line.

**NOTICE** HRM21SVA — Engaging the drive clutch while rolling backward, down a loading ramp, may damage the drive system. Avoid moving the drive clutch lever while loading and unloading.

## 9. MAINTENANCE

Periodic maintenance and adjustment are necessary to keep the mower in good operating condition. Service and inspect according to the MAINTENANCE SCHEDULE.

To avoid carbon monoxide poisoning, shut the engine off before performing any maintenance.

To avoid serious burns, let the engine cool for at least 15 minutes before performing maintenance.

Use genuine Honda parts or their equivalent for maintenance and repair. Parts of lower quality may damage the mower.

### Maintenance Schedule

REGULAR SERVICE PERIOD		BEFORE EACH USE	FIRST 20 HRS (3)	EVERY 50 HRS (3)	EVERY 100 HRS (3)	EVERY 300 HRS (3)
ITEM	Perform at every indicated operating hour interval					
Blade condition and blade bolt tightness	Check	●				
Grass or side-discharge adapter (optional equipment)	Check	●				
Engine oil	Check level	●				
	Change		●		●	
Air filter	Check	●				
	Clean			● (1)		
Spark plug	Check & clean				●	
Spark Arrester (optional equipment)	Clean				●	
Flywheel brake	Check			● (2)		
Flywheel brake cable	Adjust			●		
Drive clutch cable (HRM21SVA)	Adjust		●		●	
Throttle cable	Adjust		●		●	
Valve clearance	Adjust					● (2)
Fuel tank and filter	Clean					● (2)
Fuel line	Check	Every 2 years (2)				

NOTE: (1) Service more frequently when used in dusty areas.

(2) These items should be serviced by an authorized Honda lawn mower dealer, unless you have the proper tools and are mechanically proficient. Refer to the Honda shop manual.

(3) For professional commercial use, log hours of operation to determine proper maintenance intervals.

# 9. MAINTENANCE

## ENGINE OIL CHANGE

Engine oil capacity: 0.37 US qt (0.35 l)

Drain the oil while the engine is warm to assure rapid and complete draining.

1. Place a suitable container in front of the mower deck to catch the used oil.
2. Remove the oil filler cap/dipstick.
3. Tilt the mower forward to drain the used oil through the oil filler neck.
4. Refill with the recommended oil (page 17) to the top of the oil filler neck.
5. Reinstall the oil filler cap/dipstick.

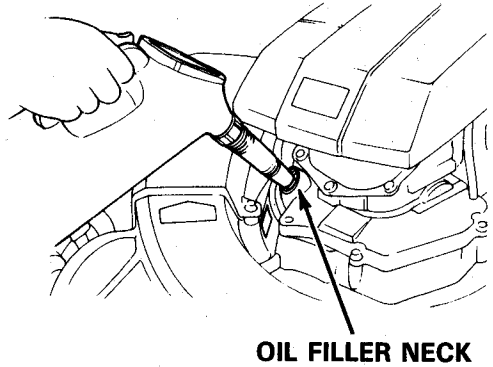
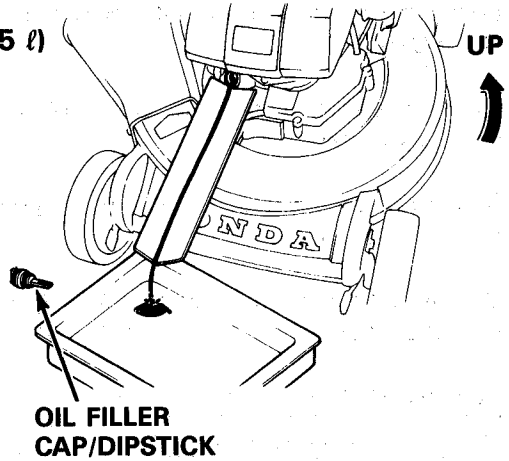

**CAUTION** Used motor oil may cause skin cancer if repeatedly left in contact with the skin for prolonged periods. Although this is unlikely, unless you handle used oil on a daily basis, it is still advisable to thoroughly wash your hands with soap and water as soon as possible after handling used oil.

NOTE: Please dispose of used motor oil in a manner that doesn't harm the environment. Do not throw it in the trash or pour it on the ground or down a drain.

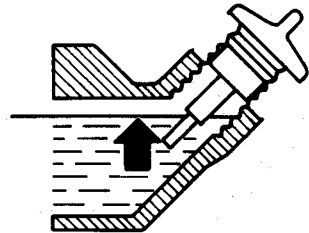

## AIR FILTER SERVICE

A dirty air filter will restrict air flow to the carburetor, reducing engine performance. If you operate the mower in very dusty areas, clean the air filter more often than specified in the MAINTENANCE SCHEDULE.

**NOTICE** Operating the engine with no air filter, or a damaged air filter, can cause rapid engine wear.

1. Remove the wing nuts, then remove the air cleaner cover.
2. Remove and inspect the filter. Replace the filter if it is damaged.
3. Tap the filter several times on a hard surface to remove dirt, or blow compressed air (not exceeding 30 psi) through the filter from the inside. Never try to brush off dirt; brushing will force dirt into the fibers.
4. Wipe dirt from the inside of the air cleaner housing and cover, using a moist rag. Be careful to avoid dropping dirt into the air duct that leads to the carburetor.
5. Reinstall the air filter and cover. Tighten the wing nuts securely.

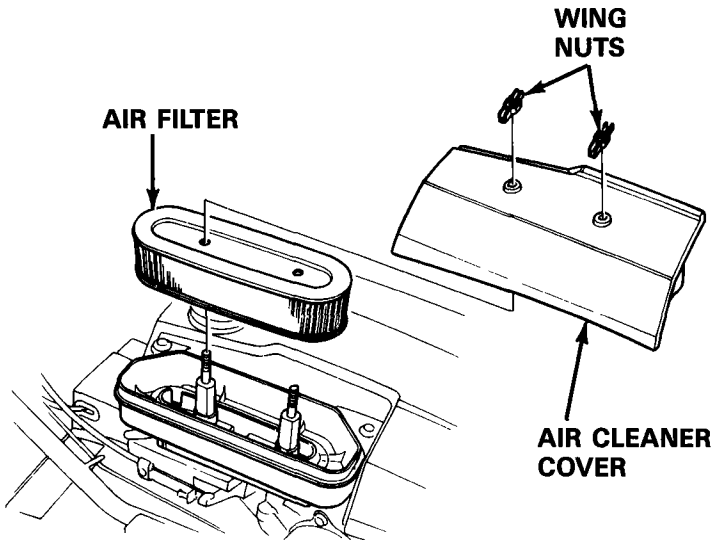

# 9. MAINTENANCE

## SPARK PLUG SERVICE

RECOMMENDED SPARK PLUGS	REGULAR	RESISTOR
NGK	B4H	BR4HS
ND	W14F-U	W14FR-U
CHAMPION	L90	RL90

NOTE: Resistor spark plugs reduce interference with radio and TV reception.

### NOTICE

Spark plugs of the wrong dimensions or heat range can cause engine damage.

For good performance, the spark plug must be properly gapped and free of deposits.

1. Disconnect the spark plug cap, and remove any dirt from around the spark plug area.

### CAUTION

Touching the engine or exhaust system while hot can cause burns. Let the engine cool before servicing.

2. Remove the spark plug with a 13/16 inch spark plug wrench.
3. Inspect the spark plug. Replace it if the electrodes are worn, or if the insulator is cracked or chipped. Clean the spark plug with a wire brush if you are going to reuse it.
4. Measure the spark plug electrode gap with a feeler gauge. The gap should be 0.024–0.028 in (0.6–0.7 mm). Correct the gap as necessary by carefully bending the side electrode.
5. Install the spark plug carefully, by hand, to avoid cross-threading.
6. After the spark plug is seated, tighten with a 13/16 inch spark plug wrench to compress the washer.

### NOTICE

A loose spark plug can get hot enough to damage the engine. Overtightening can damage the threads.

NOTE: If installing a new spark plug, tighten 1/2 turn after the spark plug seats to compress the washer. If reinstalling a used spark plug, tighten 1/8–1/4 turn after the spark plug seats.

7. Install the spark plug cap on the spark plug.

### 13/16 INCH SPARK PLUG WRENCH

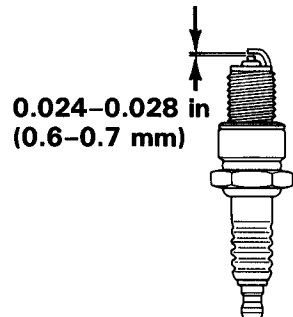
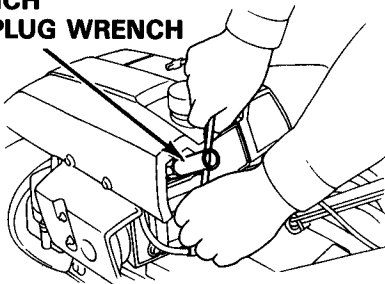

### SPARK ARRESTER MAINTENANCE (optional equipment)

The spark arrester must be serviced every 100 hours to keep it functioning as designed.

**CAUTION** Touching the engine or exhaust system while hot can cause burns. Let the engine cool before servicing.

1. Remove the two 4 mm screws from the exhaust deflector.
2. Remove the exhaust deflector, spark arrester, and gasket.
3. Check for carbon deposits on the spark arrester and the muffler port. Brush off carbon deposits. Be careful to avoid damaging the spark arrester screen.  
Remember: The spark arrester must be free of breaks and holes.
4. Reinstall the gasket, spark arrester, and exhaust deflector.
5. Tighten the two 4 mm screws securely.

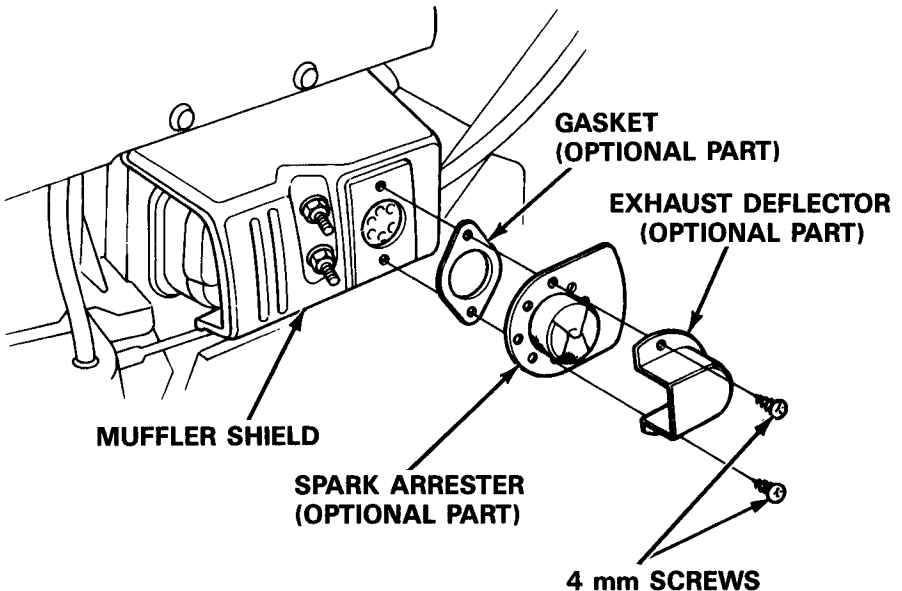

# 9. MAINTENANCE

---

## FLYWHEEL BRAKE CABLE ADJUSTMENT

1. Measure free play at the top of the lever, as shown. Free play should be less than  $3/16$  in (5 mm).
2. If adjustment is necessary, loosen the lock nuts with a 10 mm wrench, and move the adjuster up or down as required. Tighten the lock nuts and recheck free play.
3. Hold the lever forward and start the engine. Release the lever; the engine should stop quickly. If the flywheel brake does not engage and release properly with correct cable adjustment, take the mower to an authorized Honda lawn mower dealer for repair.

LESS THAN  $3/16$  in (5 mm)

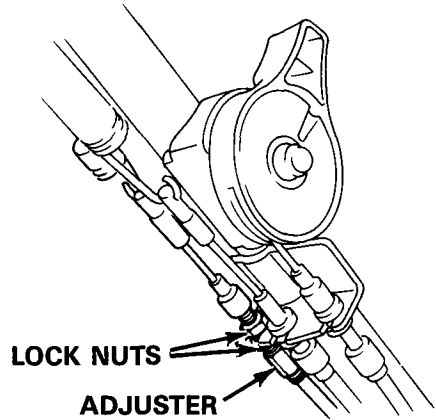
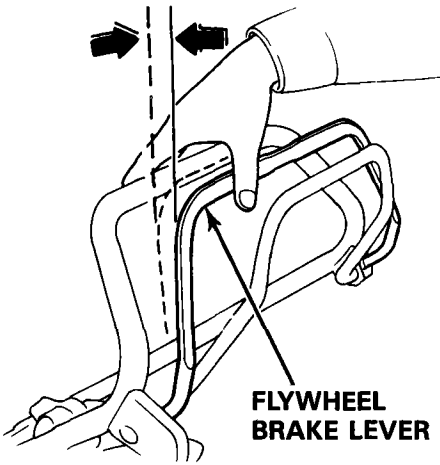

### DRIVE CLUTCH CABLE ADJUSTMENT (HRM21SVA)

1. Measure free play at the top of the lever, as shown. Free play should be  $3/16$ – $3/8$  in (5–10 mm).
2. If adjustment is necessary, loosen the lock nuts with a 10 mm wrench, and move the adjuster up or down as required. Tighten the lock nuts and recheck free play.
3. Start the engine and operate the drive clutch lever. Check to be sure the drive clutch engages and releases properly. If the drive clutch does not operate properly with correct cable adjustment, take the mower to an authorized Honda lawn mower dealer for repair.

$3/16$ – $3/8$  in (5–10 mm)

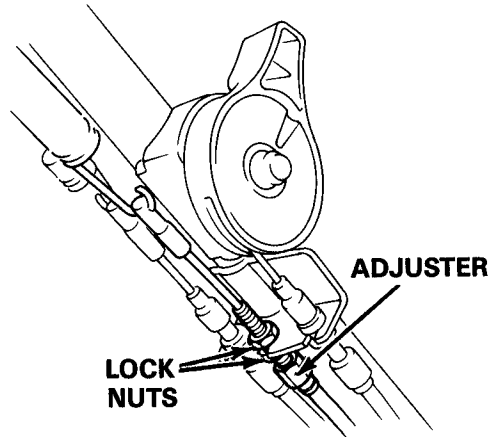
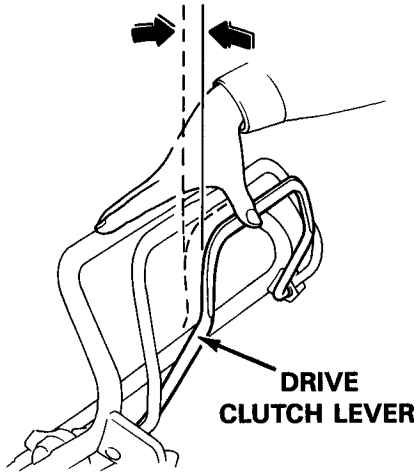



# 9. MAINTENANCE

## THROTTLE CABLE AND STOP SCREW ADJUSTMENT

When the throttle lever is moved to the START (CHOKE) position, the choke should fully close (choke arm moves inward as far as it will go), and the stop screw should contact the throttle control arm.

1. Set the throttle lever in the START (CHOKE) position.
2. Turn the stop screw counterclockwise, so it cannot contact the throttle control lever.
3. Push the choke arm with your finger to check whether it has moved inward (to the closed position) as far as it will go.

If adjustment is necessary, loosen the throttle control cable lock nuts with a 10 mm wrench, and move the adjuster up or down as required, so the choke just closes (choke arm moves inward as far as it will go). Tighten the lock nuts and recheck the choke arm position.

4. Turn the stop screw clockwise until it contacts the throttle control arm.

If the stop screw does not contact the control arm when the throttle lever is moved to the START (CHOKE) position, the throttle lever and control arm can move too far and may damage the choke arm. If the stop screw contacts the control arm too soon, the throttle lever and control arm cannot move far enough; the choke will not fully close, and the engine will be hard to start.

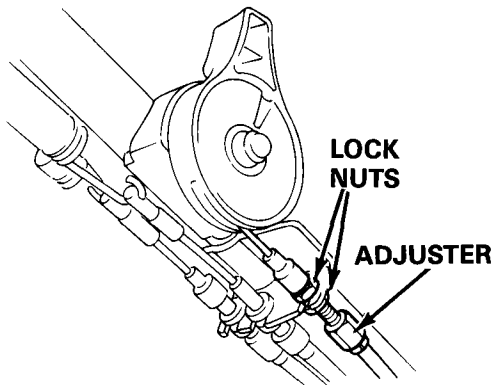
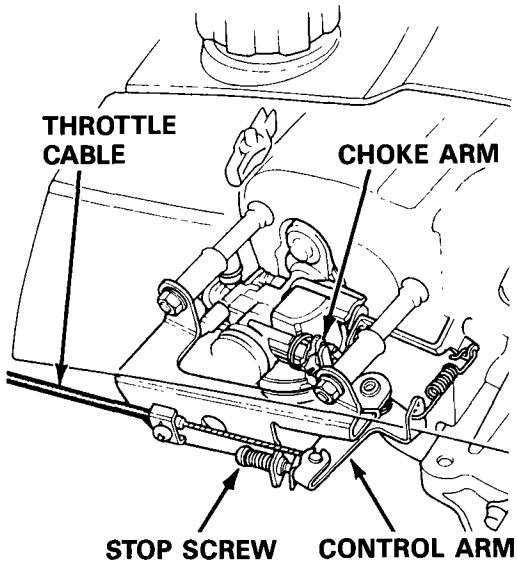
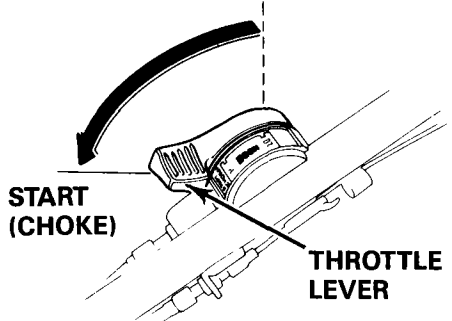

## 9. MAINTENANCE

---

### GRASS BAG CLEANING (optional equipment)

When the bag needs cleaning, wash it with a garden hose, and allow it to dry completely before use; a wet grass bag will clog quickly.

Replace a frayed, torn, or deteriorated bag with a Honda replacement bag or its equivalent.

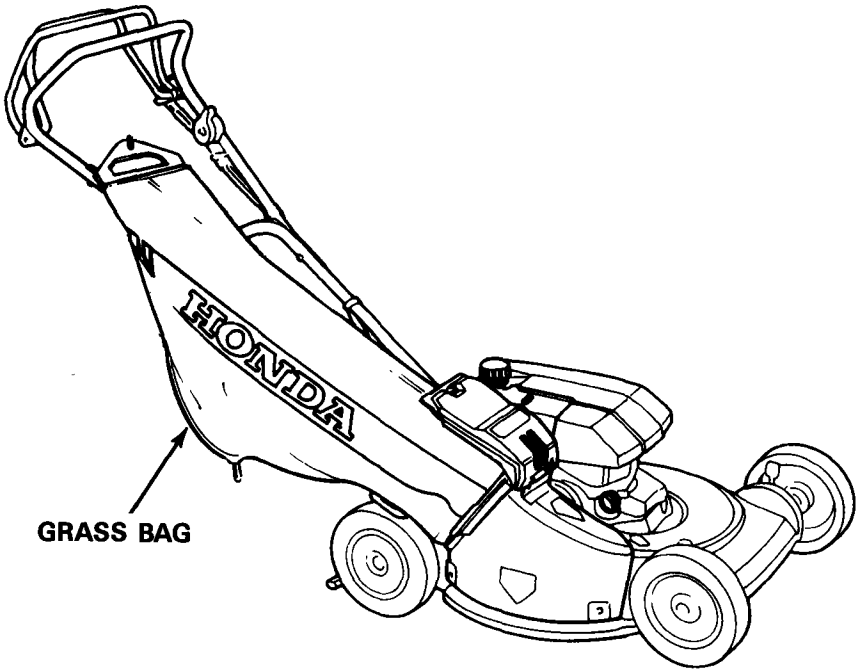

# 9. MAINTENANCE

---

## BLADE REMOVAL AND INSTALLATION

When the blade needs sharpening or replacement, take the lawn mower to an authorized Honda lawn mower dealer. Or, if you have a torque wrench, you can remove and install the blade yourself. Wear heavy gloves to protect your hands.

**Blade sharpening:** To reduce the possibility of weakening the blade, or causing imbalance or poor cutting performance, have the blade sharpened by an authorized Honda lawn mower dealer.

**Blade replacement:** Install a genuine Honda replacement blade or its equivalent. Use the standard HRM21 low-lift blade for mulching. Use the optional high-lift HRM21 blade for side-discharge mowing or bagging.

### Blade Removal

1. Turn the fuel valve OFF, and rest the mower on its left side, so the carburetor side is up.

**NOTE:** hard starting and fuel leakage may result if the mower is placed with the carburetor side down.

2. Remove the two blade nuts with a 17 mm socket wrench. Use a wooden block to prevent the blade from turning when removing nuts.
3. Remove the blade from the blade holder.

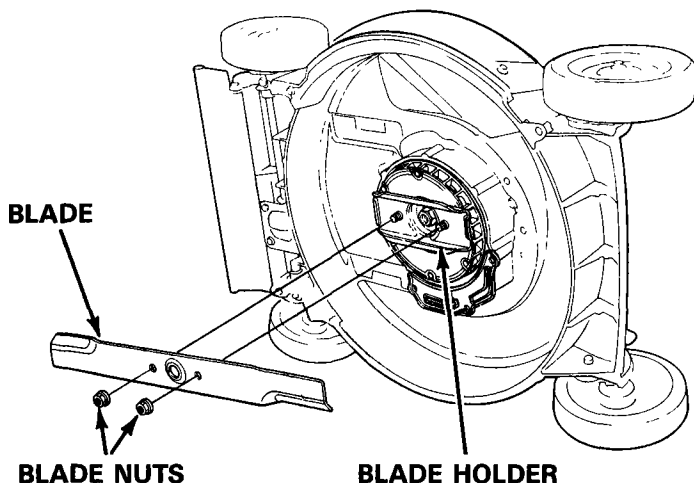

### Blade Installation

1. Clean dirt and grass from the blade mounting area.
2. Install the blade on the blade holder.

#### NOTE:

- Be sure the blade is positioned right side up (rear edges turn upward; center hole rim projects downward). If the blade is installed upside down, the edges cannot cut properly.
  - The blade nuts are specially designed for this application and must not be replaced with any other nuts.
3. Tighten the blade nuts with a torque wrench. Use a wooden block to prevent the blade from turning when tightening the nuts. If you do not have a torque wrench, have an authorized Honda lawn mower dealer tighten the blade nuts.

**Blade nut torque: 36.2–43.4 ft-lb (5.0–6.0 kg-m)**

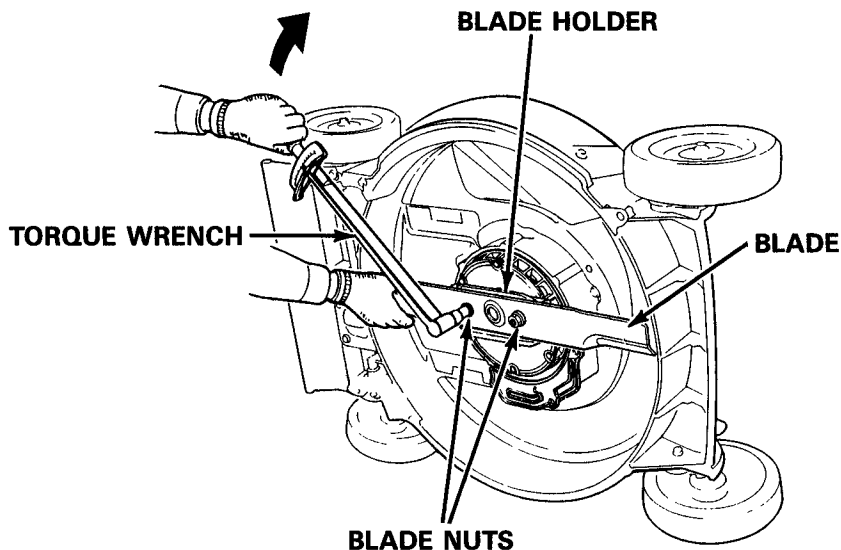

# 10. STORAGE

---

## Preparation for Storage

When the mower will not be used for one month or longer, proper storage preparation will help to prevent rust and corrosion, and will make it easier to start the engine when the mower is removed from storage.

1. Clean all surfaces of the mower, including the area underneath the mower deck. Wear heavy gloves to protect your hands.

**NOTE:** Before cleaning under the mower deck, turn the fuel valve OFF, and rest the mower on its left side, so the carburetor side is up. Hard starting and fuel leakage may result if the mower is placed with the carburetor side down.

If you use a garden hose to wash the mower, observe the following precautions:

- If the mower has been running, allow the engine to cool for at least half an hour before spraying water on it. Never spray water on a hot engine.
  - Wash the mower using low water pressure, and keep water away from controls, cable ends, wheel hubs, and all other places that are difficult to dry if water enters.
  - After washing, start the engine outdoors, and let it run until it reaches normal operating temperature to evaporate any water remaining on the engine.
  - Stop the engine, turn the fuel valve OFF, and allow the engine to cool before placing the mower in storage.
2. If equipped with the optional grass bag, wash the bag with a garden hose, and allow it to dry completely.

**NOTICE** Stored lawn clippings are a fire hazard. Always empty the grass bag after use.

3. Coat areas that may rust with a light film of oil. Lubricate all control cable cores with a silicone spray lubricant.

4. For prolonged storage, perform these additional steps:

### For storage of 1 or 2 months:

Be sure the fuel tank is completely filled. If partially filled, air in the tank will promote fuel oxidation and deterioration, resulting in bad fuel that may cause hard starting. Deteriorated fuel may also clog carburetor passages, requiring carburetor repair or replacement.

**NOTE:** The Distributor's Limited Warranty does not cover fuel system damage or engine performance problems resulting from neglected storage preparation.

- a. Fill the fuel tank with fresh gasoline, and add a gasoline conditioner, such as HONDA FUEL STABILIZER, which is formulated to extend fuel storage life.
- b. Run the engine outdoors for 10 minutes to be sure that treated gasoline has replaced the untreated gasoline in the carburetor.
- c. Stop the engine, turn the fuel valve OFF, and allow the engine to cool before placing the mower in storage.

### For storage of more than 2 months:

- a. Change the engine oil (see page 34).
- b. Remove the spark plug (see page 36). Pour a tablespoon of clean engine oil into the cylinder. Pull the starter rope several times to distribute the oil in the cylinder. Reinstall the spark plug.

**NOTE:** While the spark plug is removed, inspect the plug, and clean, gap, or replace it if necessary.

- c. Pull the starter rope until you feel resistance. This closes the valves, which helps to protect the cylinder from corrosion.

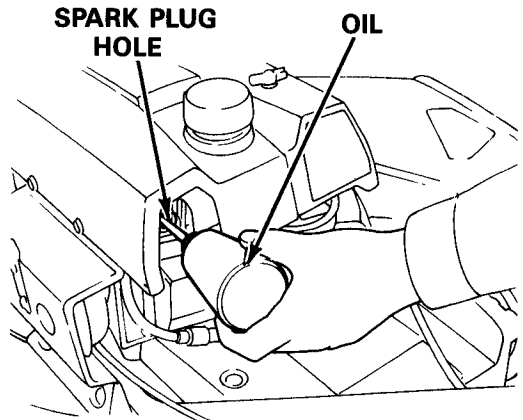

## 10. STORAGE

For storage of more than 2 months (continued):

- d. Disconnect the fuel line from the fuel valve, and drain the fuel tank into an approved gasoline container.

**▲WARNING** Gasoline is extremely flammable, and gasoline vapor can explode. Use extreme care when handling gasoline.

- e. Remove the carburetor float bowl by squeezing the retaining tabs on the sides of the bowl. Empty the float bowl into an approved gasoline container.
- f. Install the carburetor float bowl. Connect the fuel line. Turn the fuel valve OFF.

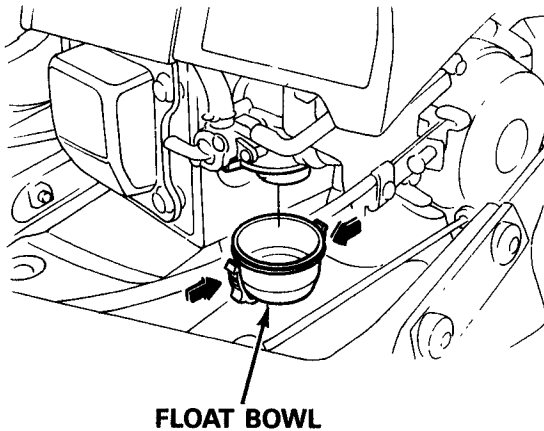
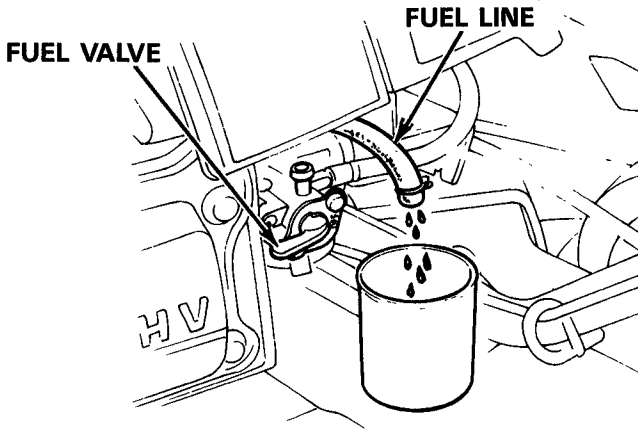

### Storage

Select a storage area away from appliances (water heater or clothes dryer) that use an open flame as a heat source. Power tools, and some battery operated toys, have electric motors that produce sparks that can ignite gasoline vapors.

**▲WARNING** Gasoline is extremely flammable, and gasoline vapor can explode. Be careful to avoid open flames or sparks.

Avoid storing the mower where it will be exposed to high humidity and dust.

Place the mower with its wheels on a level surface. Tilting the mower may result in fuel leakage.

Cover the mower to keep out dust.

NOTE: Plastic sheets should not be used as dust covers; they trap moisture under the covers, promoting rust and corrosion.

### Removal from Storage

Check all items described in the PRE-OPERATION CHECK section of this manual (pages 15–21).

NOTE:

- Fill the fuel tank with fresh gasoline. If you keep a container of gasoline for refueling, be sure that it contains only fresh gasoline. Gasoline oxidizes and deteriorates over time, resulting in bad fuel that may cause hard starting.

**▲WARNING** Gasoline is extremely flammable, and gasoline vapor can explode. Use extreme care when handling gasoline.

- If the cylinder was coated with oil during storage preparation, the engine will smoke briefly at start up. This is normal.



# 11. TROUBLESHOOTING

## ENGINE

ENGINE WILL NOT START	POSSIBLE CAUSE	CORRECTION
1. Check control positions.	Fuel valve OFF. Throttle lever in wrong position.  Flywheel brake engaged.	Turn fuel valve ON (p. 22). Move throttle lever to START (CHOKE) position, unless the engine is warm (p. 22). Push flywheel brake lever forward to the handlebar.
2. Check fuel.	Out of fuel. Bad fuel; mower stored without treating or draining gasoline, or refueled with bad gasoline.	Refuel (p. 18). Drain fuel tank and carburetor (p. 46). Refuel with fresh gasoline (p. 18).
3. Remove and inspect spark plug.	Spark plug faulty, fouled, or improperly gapped. Spark plug wet with fuel.	Clean, gap, or replace spark plug (p. 36). Dry spark plug and clear flooded engine (p. 24).
4. Take mower to Honda lawn mower dealer for service or repair.	Fuel filter clogged, carburetor malfunction, ignition malfunction, valves stuck, etc.	Take mower to Honda lawn mower dealer, or refer to shop manual.

LOSS OF POWER	POSSIBLE CAUSE	CORRECTION
1. Check under mower deck.	Mower deck clogged.	Clean out the mower deck (p. 29).
2. Check air filter.	Air filter clogged.	Clean or replace air filter (p. 35).
3. Check fuel.	Bad fuel; mower stored without treating or draining gasoline, or refueled with bad gasoline.	Drain fuel tank and carburetor (p. 46). Refuel with fresh gasoline (p. 18).
4. Check vent inside fuel tank cap.	Fuel tank cap vent clogged.	Clean fuel tank cap vent.
5. Take mower to Honda lawn mower dealer for service or repair.	Fuel filter clogged, carburetor malfunction, valve clearance out of adjustment, low compression, etc.	Take mower to Honda lawn mower dealer, or refer to shop manual.

# 11. TROUBLESHOOTING

## VIBRATION

EXCESSIVE VIBRATION	POSSIBLE CAUSE	CORRECTION
1. Check blade.	Blade is loose, bent, damaged, or unbalanced by improper sharpening.	Tighten loose blade bolts. Replace blade if necessary (p. 15 & 42).
2. Take mower to Honda lawn mower dealer for repair.	Mechanical damage, such a bent crankshaft.	Take mower to Honda lawn mower dealer, or refer to shop manual.

## GRASS CUTTING/MULCHING/BAGGING

POOR CUT QUALITY OR POOR CUTTING/MULCHING/BAGGING PERFORMANCE	POSSIBLE CAUSE	CORRECTION
1. Check that throttle lever is in the HI position.	Engine speed is too slow to cut well.	Move throttle lever to the HI position (p. 25).
2. Reduce forward speed.	Mower is moving too fast for lawn conditions.	Push slower (p. 31).
3. Check cutting height adjustment levers.	Adjustment levers set at different positions.  Cutting height set too low for lawn conditions.	Set all levers in the same cutting height position (p. 14).  Raise the cutting height (p. 14 & 31).
4. Check grass bag (optional equipment).	Grass bag is overfilled or clogged.	Empty the grass bag (p. 11 & 31). Wash the bag if clogged with dirt (p. 41).
5. Check mower deck and blade.	Mower deck is clogged. Blade is dull, worn, or damaged.  Wrong blade installed.	Clean out mower deck (p. 29). Check blade installation. Sharpen or replace blade if necessary (p. 15 & 42).  Use low-lift blade for mulching. Use high-lift blade for side-discharge mowing or bagging (p. 10).

## 12. SPECIFICATIONS

### MOWER MODELS

HRM21PVA:	Manually propelled model
HRM21SVA:	Self-propelled model

### DIMENSIONS

Overall Length	59.1 in (150 cm)
Width at mower deck	23.0 in (58.5 cm)
Overall Height	39.4 in (100 cm)
Dry Weight	HRM21PVA: 67.3 lb (30.5 kg) HRM21SVA: 71.7 lb (32.5 kg)
Grass Bag Capacity (optional equipment)	1.56 bushels; 14.5 US gal (55 ℓ)
Cutting Width	21 in (53 cm)
Cutting Height (adjustable)	3/4 in, 1-1/4 in, 1-3/4 in, 2-1/4 in, 2-5/8 in, 3 in

### ENGINE

Engine Model	GXV110
Engine Type	4-stroke, overhead-valve, single cylinder, forced air-cooled
Displacement	6.7 cu in (110 cc)
Bore and Stroke	2.0 x 2.2 in (50 x 56 mm)
Maximum Horsepower	3.5 hp at 3,600 rpm
Maximum Torque	0.46 ft-lb at 2,500 rpm
Max. Governed Speed	3,100 ± 150 rpm
Ignition System	Transistorized magneto
Spark Plug	Regular: NGK B4H, ND W14F-U, Champion L90 Resistor: NGK BR4HS, ND W14FR-U, Champion RL90
Spark Plug Gap	0.024–0.028 in (0.6–0.7 mm)
Fuel	Use gasoline with a pump octane rating of 86 or higher (p. 19). Unleaded gasoline is preferred.
Fuel Tank Capacity	0.21 US gal (0.8 ℓ)
Engine Oil	SAE 10W–30 is recommended for general, all- temperature use (p. 17).
Engine Oil Capacity	0.37 US qt (0.35 ℓ)

NOTE: Specifications are subject to change without notice.

## 13. WARRANTY SERVICE

---

### Owner Satisfaction

Your satisfaction and goodwill are important to your dealer and to us. All Honda warranty details are explained in the Distributor's Limited Warranty. Normally, any problems concerning the product will be handled by your dealer's service department. If you have a warranty problem that has not been handled to your satisfaction, we suggest you take the following action:

- Discuss your problem with a member of the dealership management. Often complaints can be quickly resolved at that level. If the problem has already been reviewed with the Service Manager, contact the owner of the dealership or the General Manager.
- If your problem still has not been resolved to your satisfaction, contact the Power Equipment Customer Relations Department of American Honda Motor Co., Inc.

American Honda Motor Co., Inc.  
Power Equipment Division  
P.O. Box 100021  
Duluth, Georgia 30136-9421  
Telephone: (404) 497-6400

We will need the following information in order to assist you:

- Your name, address, and telephone number
- Product model and serial number (see page 8)
- Date of purchase
- Dealer name and address
- Nature of problem

After reviewing all the facts involved, you will be advised of what action can be taken. Please bear in mind that your problem will likely be resolved at the dealership, using the dealer's facilities, equipment, and personnel, so it is very important that your initial contact be with the dealer.

Your purchase of a Honda product is greatly appreciated by both your dealer and American Honda Motor Co., Inc. We want to assist you in every way possible to assure your complete satisfaction with your purchase.

31VA2031  
00X31-VA2-2031

 100009012  
PRINTED IN U.S.A.