

HONDA

Power

Equipment

Owner's Manual Rotary Mower

HRC216SXA

HRC216HXA

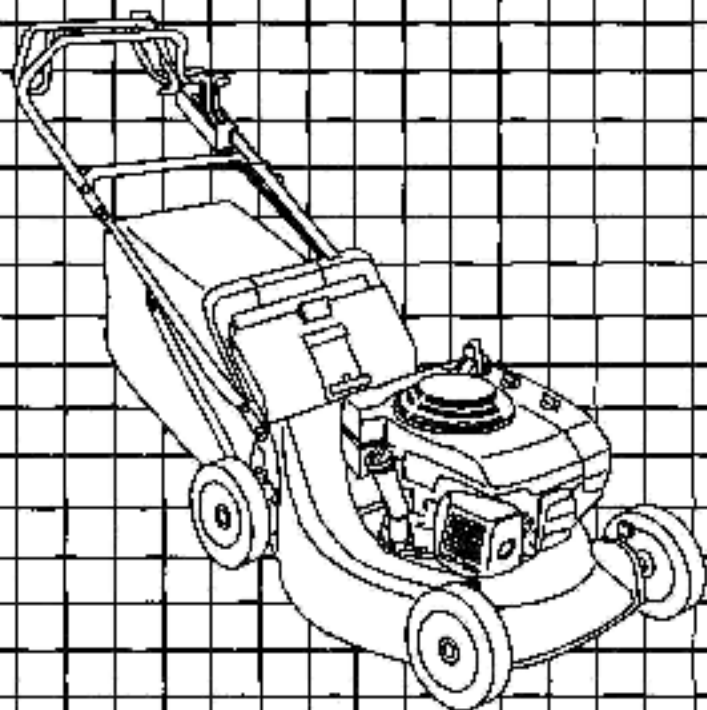

Keep this owner's manual handy, so you can refer to it any time, and make sure the manual stays with the lawn mower if you sell it.

This owner's manual is considered a permanent part of the lawn mower and should remain with the mower if resold.

The information and specifications included in this publication were in effect at the time of approval for printing. Honda Power Equipment Mfg., Inc. reserves the right, however, to discontinue or change specifications or design at any time without notice and without incurring any obligation whatever.

Honda lawn mowers meet Consumer Product Safety Commission (CPSC) blade safety requirements for walk-behind rotary mowers.



WARNING:



The engine exhaust from this product contains chemicals known to the State of California to cause cancer, birth defects or other reproductive harm.

Congratulations on your selection of a Honda lawn mower! We are certain you will be pleased with your purchase of one of the finest lawn mowers on the market.

We want to help you get the best results from your new mower and to operate it safely. This manual contains the information on how to do that; please read it carefully.

As you read this manual, you will find information preceded by a **NOTICE** symbol. That information is intended to help you avoid damage to your mower, other property, or the environment.

We suggest you read the warranty policy to fully understand its coverage and your responsibilities of ownership. The warranty policy is a separate document that should have been given to you by your dealer.

When your mower needs scheduled maintenance, keep in mind that your authorized Honda servicing dealer is specially trained in servicing Honda mowers and is supported by the parts and service divisions of American Honda. Authorized Honda servicing dealers are dedicated to your satisfaction and will be pleased to answer your questions and concerns.

Best Wishes,
Power Equipment Division
American Honda Motor Co., Inc.

INTRODUCTION

A FEW WORDS ABOUT SAFETY

Your safety, and the safety of others, are very important. And using this lawn mower safely is an important responsibility.

To help you make informed decisions about safety, we have provided operating procedures and other information on labels and in this manual. This information alerts you to potential hazards that could hurt you or others.

Of course, it is not practical or possible to warn you about all the hazards associated with operating or maintaining a mower. You must use your own good judgment.

You will find important safety information in a variety of forms, including:

- **Safety Labels** — on the lawn mower.
- **Safety Messages** — preceded by a safety alert symbol  and one of three words: DANGER, WARNING, or CAUTION.

These signal words mean:

 **DANGER**

You **WILL** be **KILLED** or **SERIOUSLY HURT** if you don't follow instructions.

 **WARNING**

You **CAN** be **KILLED** or **SERIOUSLY HURT** if you don't follow instructions.

 **CAUTION**

You **CAN** be **HURT** if you don't follow instructions.

- **Safety Headings** — such as Important Safety Reminders or Important Safety Precautions.
- **Safety Chapter** — such as MOWER SAFETY.
- **Instructions** — how to use this mower correctly and safely.

This entire book is filled with important safety information — please read it carefully.

CONTENTS

Turn to the beginning of each chapter for a complete list of subjects.

MOWER SAFETY	5
Important information about some specific hazards, and what you can do to prevent injury.	
CONTROLS	11
Identification of components and information about how the controls work.	
BEFORE OPERATION	19
How to fuel and check your mower to be sure it is ready. How to prepare your lawn and yourself before you begin mowing.	
OPERATION	27
Starting and stopping the engine, safe mowing practices, and mowing tips.	
TRANSPORTING	39
How to load and carry your mower safely.	
MAINTENANCE	41
When and how to perform routine inspection, service, and adjustments to keep your mower in good operating condition.	
TROUBLESHOOTING	63
What to check if you have a problem with your mower.	
STORAGE	67
How to protect your mower from rust and corrosion, and ensure that it will start easily when you want to use it again.	
SPECIFICATIONS	73
Dimensions, capacities, and other technical information.	
ADDITIONAL INFORMATION	77
Additional information, Honda publications available to you, and how to contact us if you have a question or a warranty repair problem.	
INDEX	83
QUICK REFERENCE INFORMATION ...	inside back cover

MOWER SAFETY

This chapter explains what you need to know to operate your mower safely.

IMPORTANT SAFETY INFORMATION	6
Avoid Rotating Blades	6
Clear Mowing Area	6
Keep Shields in Place	6
Refuel with Care	6
Wear Protective Clothing	6
Turn Engine Off When Not Mowing	6
IMPORTANT MESSAGE TO PARENTS	7
IMPORTANT MESSAGE TO EMPLOYERS	8
SAFETY LABEL LOCATIONS	9

MOWER SAFETY

IMPORTANT SAFETY INFORMATION

Most accidents with walk-behind mowers can be prevented if you follow all instructions in this manual and on the mower. The most common hazards, according to accident statistics, are discussed below, along with the best way to protect yourself and others.

Avoid Rotating Blades

Rotating blades can cause serious cuts and even amputate fingers, hands, toes, or feet. Keep away from the mower deck whenever the engine is running. If you need to adjust the cutting height, or work around the deck for any other reason, always shut off the engine. Wear heavy gloves and disconnect the spark plug cap when you need to clean the mower deck or handle the blade.

Clear Mowing Area

Mower blades can throw rocks and other objects with enough force to cause serious injury. Before mowing, carefully inspect the area and remove all sticks, stones, pieces of wire, and other loose objects. Never operate the blade over gravel.

Keep Shields in Place

Guards and shields are designed to protect you from being hit by thrown objects and from hot engine parts and moving components. For your safety and the safety of others, keep all shields in place when the engine is running.

Refuel with Care

Gasoline is extremely flammable and gasoline vapor can explode. Refuel only outdoors, in a well-ventilated area, with the engine OFF. Never smoke near gasoline, and keep other flames and sparks away. Always store gasoline in an approved container.

Wear Protective Clothing

Wearing protective clothing will reduce your risk of injury. Long pants and eye protection reduce the risk of injuries from thrown objects. Sturdy shoes with aggressive soles will help protect your feet and give you better traction on slopes or uneven ground.

Turn Engine Off When Not Mowing

If you need to leave the mower for any reason, even just to inspect the lawn ahead, always turn the engine off.

IMPORTANT MESSAGE TO PARENTS

YOUR CHILDREN'S SAFETY IS VERY IMPORTANT to Honda. That's why we urge you to read this message before letting your youngster operate this lawn mower. Lawn mowers are tools, not toys. As with any equipment, bad judgments can result in serious injuries. You can help prevent accidents by making good decisions about if, when, and how your youngster operates this equipment.

The first question you'll need to ask is whether your youngster is capable of operating this mower safely. Remember, young people vary widely, and **AGE IS NOT THE ONLY FACTOR**.

Physically, a youngster must be **LARGE ENOUGH AND STRONG ENOUGH** to easily start the mower and control its direction. The youngster also needs enough size, strength, and coordination to comfortably reach and operate the controls.

Another, tougher question you need to ask is if your youngster has enough **MATURITY AND RESPONSIBILITY** to safely operate this mower. Does the young person think through problems and come to logical solutions? Be honest! Anyone who takes unnecessary risks and doesn't obey rules should not operate this lawn mower.

If you decide that your son or daughter can handle the mower safely, **CAREFULLY READ THE OWNER'S MANUAL** with your youngster. Make sure you both understand all instructions and safety information. Also, be sure your youngster wears sturdy shoes and other protective clothing when operating or handling the mower.

SUPERVISION is also very important. Walk with your youngster during the first few minutes of mowing. Even after the youngster has become confident with the mower, do not let the young person use the mower without good adult supervision. An adult should also be present during refueling and maintenance. In fact, it's up to parents to make sure that the mower is properly maintained and kept in safe operating condition.

By always placing safety first, your youngster will acquire useful skills and a sense of accomplishment. And you'll both get the best results from your lawn mower.

MOWER SAFETY

IMPORTANT MESSAGE TO EMPLOYERS

As an employer, you have special responsibilities to the people who work for you.

Before you ask anyone to operate this mower, you need to determine whether the person is old enough, large enough, and strong enough to safely handle and control the mower.

If you decide they are, make sure the employee reads and understands all instructions and warnings in this manual and on the labels before operating the mower.

Allow adequate time for hands-on training by a qualified instructor, and personally supervise practice sessions until you feel sure the employee is ready to operate the machine.

Also be sure employees wear proper clothing and have eye protection and any other gear that may be required by local ordinances or your insurance company.

Remember, too, that you are responsible for keeping the mower properly maintained and in safe operating condition.

Your commitment to safety on the job can help prevent accidents and result in longer and more productive years of service.

SAFETY LABEL LOCATIONS

The labels shown here contain important safety information. Please read them carefully. These labels are considered permanent parts of your mower. So if a label comes off or becomes hard to read, contact an authorized Honda servicing dealer for a replacement.

⚠ CAUTION

UNDER NORMAL USAGE, THIS BAG MATERIAL IS SUBJECT TO DETERIORATION AND WEAR, AND SHOULD BE CHECKED FREQUENTLY FOR BAG REPLACEMENT. THIS BAG CONFORMS TO A.N.S.I. STANDARD B71.1. ANY REPLACEMENT MUST MEET THIS STANDARD.

⚠ WARNING

DO NOT START UNLESS GUARD IS CLOSED OR BAG IS IN PLACE.

- READ OWNER'S MANUAL BEFORE OPERATING
- DISCONNECT THE SPARK PLUG CAP BEFORE SERVICING THE DECK OR BLADE.
- DO NOT ALLOW ANYONE TO STAND IN FRONT OF MOWER.
- TO PREVENT INJURY FROM THROWN OBJECTS; CLEAR AREA OF DEBRIS KEEP OTHERS AWAY
- TO PREVENT SERIOUS INJURY, DO NOT REACH INSIDE WHEN ENGINE IS RUNNING.
- DO NOT REMOVE GUARDS.

⚠ WARNING

Gasoline is highly flammable and explosive and you can be burned or seriously injured.

When refueling:

- Keep heat, sparks, and open flame away.
- Fill fuel tank only outdoors.
- Wipe up spills before starting engine.

DANGER

KEEP HANDS and FEET AWAY

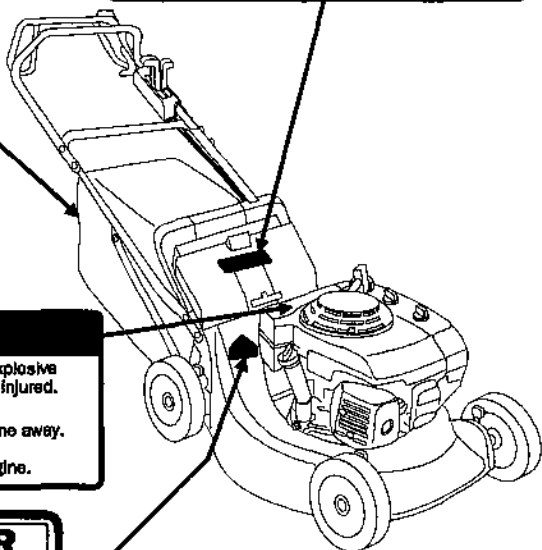

CONTROLS

This chapter shows the locations of controls and other important parts of your mower, and it tells you how the controls work.

COMPONENT IDENTIFICATION	12
DESCRIPTION OF CONTROLS	14
Fuel Valve	14
Throttle Lever	14
Blade Control Lever	15
Drive Clutch Lever	15
Shift Lever	16
Cutting Height Adjustment Levers	17

CONTROLS

COMPONENT IDENTIFICATION

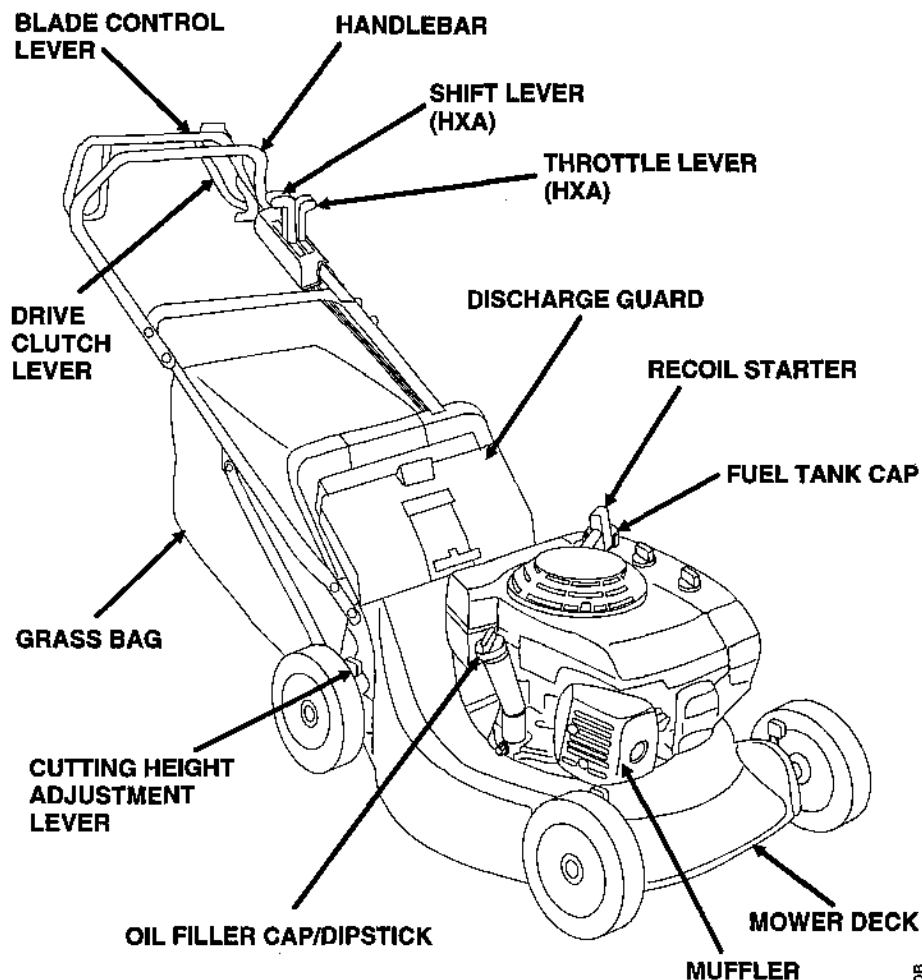

HRC216K1SXA: Manual starting; self-propelled; 2-speed transmission

HRC216K1HXA: Manual starting; self-propelled; hydrostatic transmission

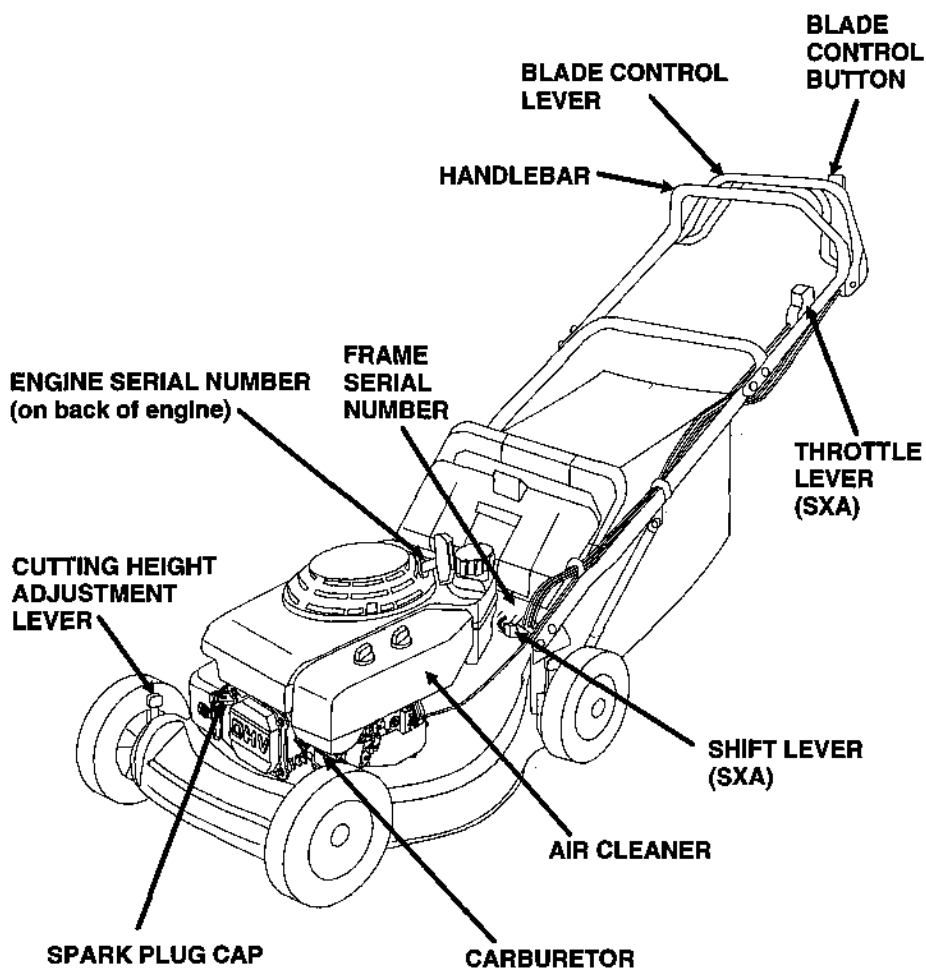

Record the frame and engine serial numbers in the space below. You will need these serial numbers when ordering parts and when making technical or warranty inquiries (see page 79).

Frame serial number: MZAN – _____

Engine serial number: GJO3 – _____

CONTROLS

DESCRIPTION OF CONTROLS



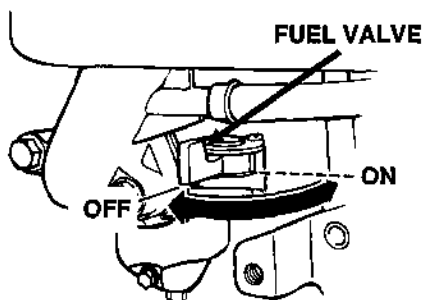

Fuel Valve

The fuel valve opens and closes the connection between the fuel tank and the carburetor.



VBSFAAAA.CDR

Throttle Lever

-  CHOKE --- For starting a cold engine.
-  FAST --- For restarting a warm engine and for mowing.
-  SLOW --- For idling the engine.
-  STOP --- For stopping the engine.

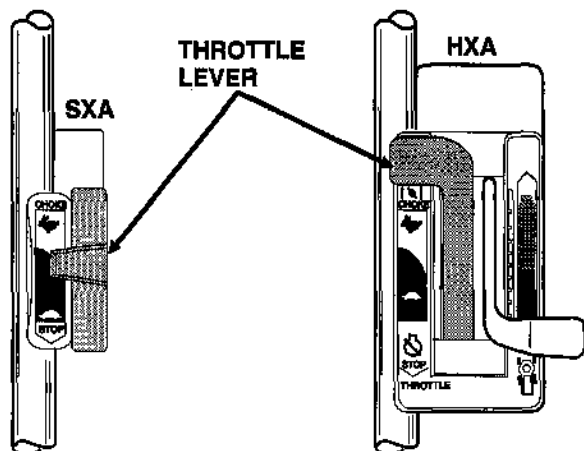

VBSGA AAA.CDR

Blade Control Lever

The blade control lever starts and stops blade rotation.

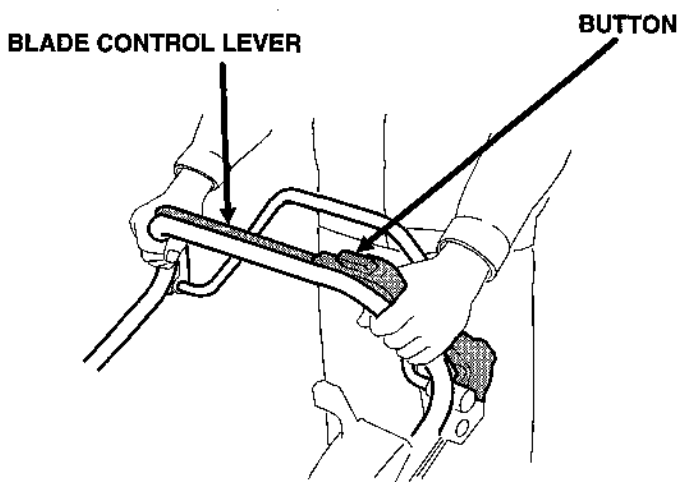

VASCADAA CDR

Drive Clutch Lever

The drive clutch lever engages and disengages the transmission that drives the rear wheels.

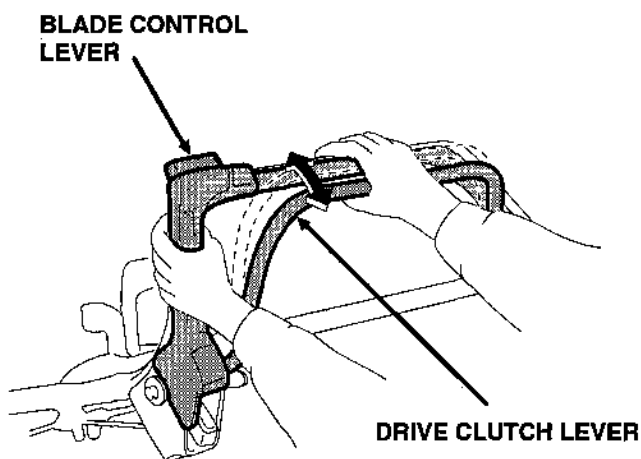

VASCADAA CDR

CONTROLS

Shift Lever

HRC216HXA

The shift lever controls the mower's maximum drive speed.

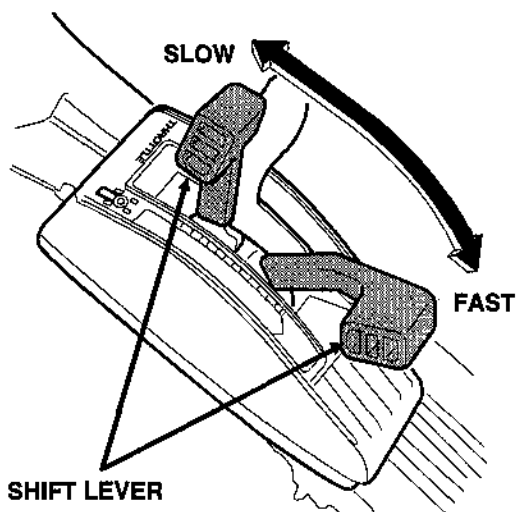

VA3CAEAA.CDR

HRC216SXA

The shift lever selects the drive speed for the mower.

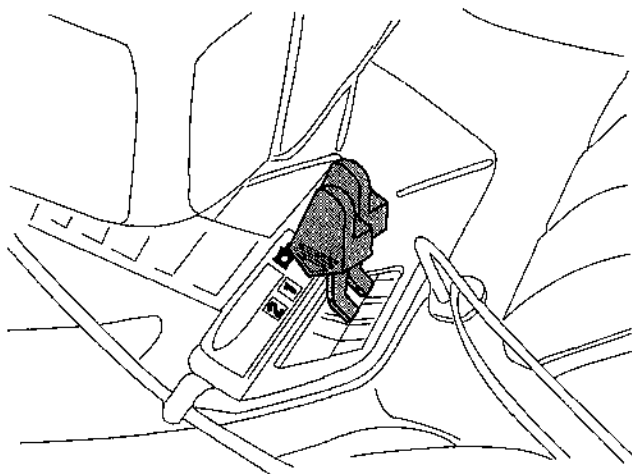

VBSCABAA.CDR

Cutting Height Adjustment Levers

There are six settings to choose from, as shown in the illustration. The cutting height figures are approximate. The actual height of cut grass will vary with lawn and soil conditions.

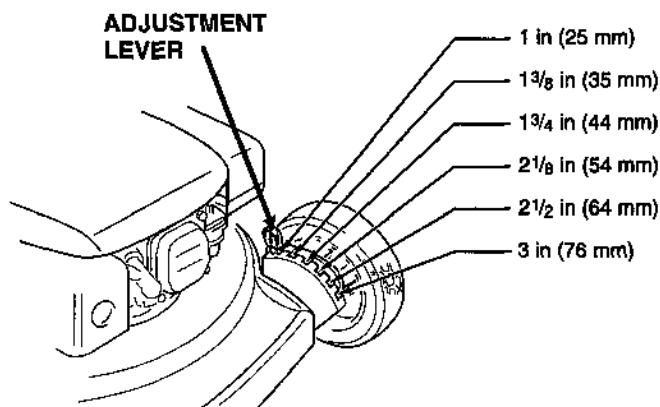

VB5CACA1 CDR

There is an adjustment lever for each wheel.

ADJUSTMENT LEVERS

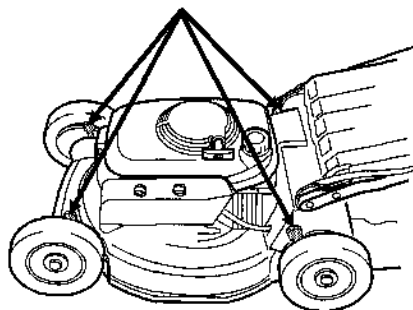

VB5CADA0 CDR

BEFORE OPERATION

This chapter explains how to fuel and check your mower to be sure it is ready, and it tells you how to prepare your lawn and yourself before you begin mowing.

ARE YOU READY TO MOW?	20
CHECK YOUR LAWN	20
Objects	20
People and Pets	20
Lawn	20
CHECK YOUR MOWER	21
Blade	21
Engine Oil Level	22
Fuel	23
Air Cleaner Inspection	24
Grass Bag	25
Inspection	25
Installation	25
Removal	25
Cutting Height	26

BEFORE OPERATION

ARE YOU READY TO MOW?

Be sure to wear protective clothing. Long pants and eye protection can lower your risk of injury from thrown objects. Wear footwear that protects your feet and won't let you slip if you mow on slopes or uneven ground.

CHECK YOUR LAWN

For your safety and for the safety of others, always inspect the area before mowing.

Objects

Anything which can be picked up by the blades and thrown is a potential hazard to you and others. Look for things like stones, sticks, bones, and wire. Remove them from the mowing area.

People and Pets

People and animals near the mowing area can move into your path or into a position where they could be struck by thrown objects. Clear the area of people and pets, especially children. Their safety is your responsibility.

Lawn

Check the length and condition of the grass, so you will know what cutting height and mowing speed to use.

Avoid mowing wet grass. Not only will wet grass clog your mower deck and collect in clumps on the lawn, it also gives poor traction, increasing your risk of losing your footing.

CHECK YOUR MOWER

Blade

1. Move the throttle lever to the STOP position (see page 14).
2. Move the fuel valve to the OFF position (see page 14).
3. Remove the spark plug cap from the spark plug (see page 50).
4. Tilt the mower to the right, so the carburetor side is up. This will help to prevent fuel leakage and hard starting.
5. Inspect the blade for wear and damage.

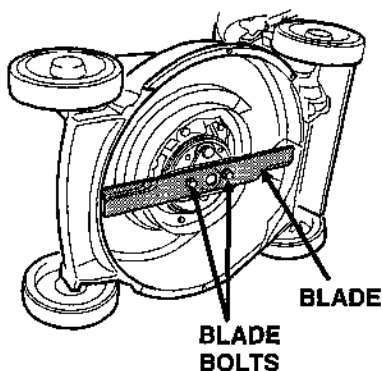

VB5BAAA.CDR



NORMAL



**EXCESSIVELY
WORN**



BENT



CRACKED

L1M-AACAA.CDR

A dull blade can be sharpened, but a blade that is worn out, bent, cracked, or otherwise damaged must be replaced. A worn or damaged blade can break, causing blade pieces to be thrown from the mower.

When the blade needs sharpening or replacement take the lawn mower to an authorized Honda servicing dealer. Or, if you have a torque wrench, you can remove and install the blade yourself (see pages 59 - 60).

Check that the blade bolts are tight (see page 60).

BEFORE OPERATION

Engine Oil Level

Check the engine oil level with the engine stopped and the mower on a level surface.

1. Remove the oil filler cap, and wipe the dipstick clean.
2. Insert and remove the dipstick without screwing it into the filler neck. Check the oil level shown on the dipstick.

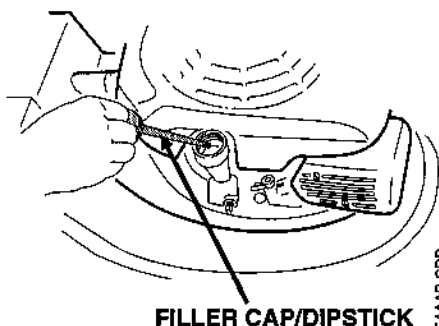

VE2EAA8.CDR

3. If the oil level is low, add oil to reach the upper limit mark on the dipstick. Do not overfill (see page 48).

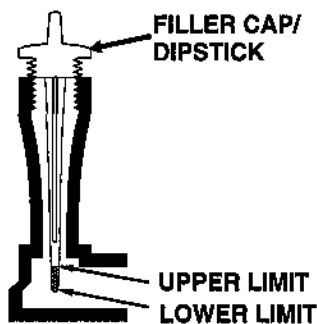

LM-AADA.A.CDR

4. After checking the engine oil level, screw in the filler cap/dipstick securely.

Fuel

Fuel tank capacity: 0.53 US gal (2.0 ℓ)

Refuel in a well-ventilated area before starting the engine. If the engine has been running, allow it to cool. Refer to page 53 for fuel recommendations and page 80 for information about oxygenated fuels.

Remove the fuel tank cap and check the fuel level. Refill the tank if the fuel level is low. Refuel carefully to avoid spilling fuel. Do not overfill; fuel should be below the upper level indicator in the filler neck. After refueling, tighten the fuel tank cap securely.

⚠ WARNING

Gasoline is highly flammable and explosive.

You can be burned or seriously injured when handling fuel.

- Stop the engine and keep heat, sparks, and flame away.
- Refuel only outdoors.
- Wipe up spills immediately.

Never refuel the mower inside a building where gasoline fumes may reach flames or sparks. Keep gasoline away from appliance pilot lights, barbecues, electric appliances, power tools, etc.

Spilled fuel is not only a fire hazard, it causes environmental damage. Wipe up spills immediately.

NOTICE

Fuel can damage paint and plastic. Be careful not to spill fuel when filling your fuel tank. Damage caused by spilled fuel is not covered under warranty.

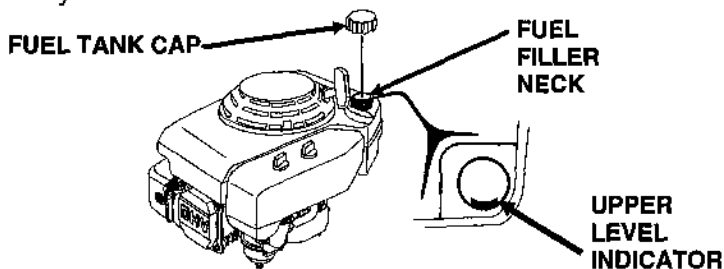

BEFORE OPERATION

Air Cleaner Inspection

Check that the air filter is clean and in good condition. A dirty air filter will restrict air flow to the carburetor, reducing engine performance. Refer to page 49 for air cleaner service.

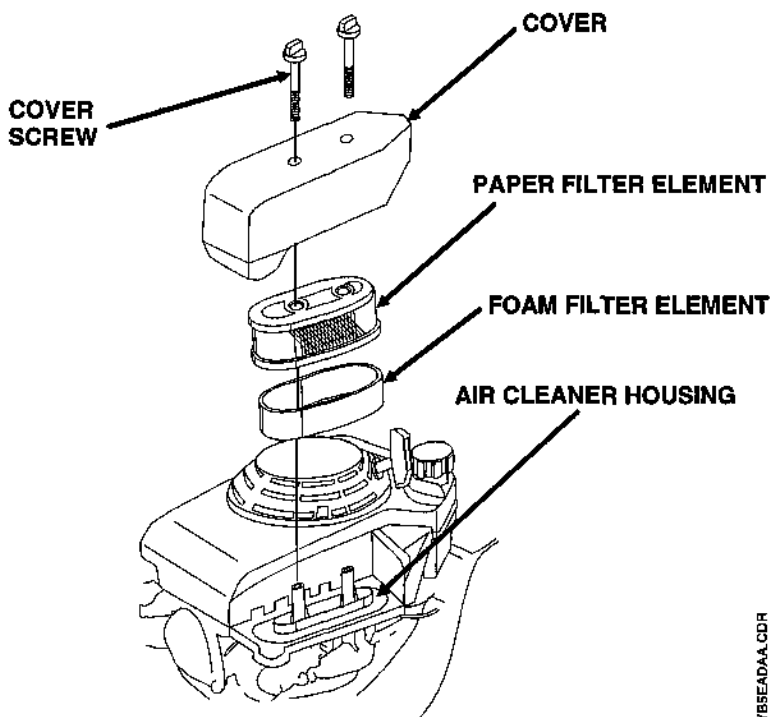

WBE5EADAA.CDR

Grass Bag

A lawn mower works like a vacuum cleaner; it blows air through the bag, which traps the grass clippings. Always empty the grass bag before it becomes filled to the limit of its capacity. Bagging performance will diminish after the bag becomes about 90% filled. Also, the bag is easier to empty when it is not packed full.

Inspection

Inspect the grass bag for tears, holes, and excessive wear. The grass bag wears during normal use and will eventually require replacement. Grass bag replacement is explained on page 61.

Installation

1. Raise the discharge guard, and hook the grass bag onto the mower deck as shown.
2. Release the discharge guard to secure the grass bag.

Removal

1. Raise the discharge guard, grasp the handle of the grass bag lid, and remove the grass bag.
2. Release the discharge guard.
3. When the grass bag is clear of the discharge guard, you can lift it through the handlebar opening, or you can remove it to the rear of the mower below the handlebar.

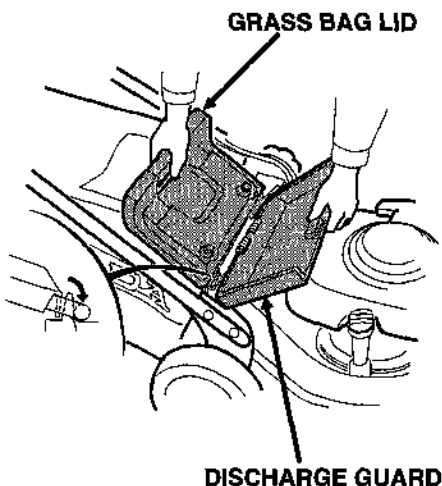

BEFORE OPERATION

Cutting Height

Check the mower deck cutting height settings, and be sure that all four adjustment levers are set to the same cutting height position.

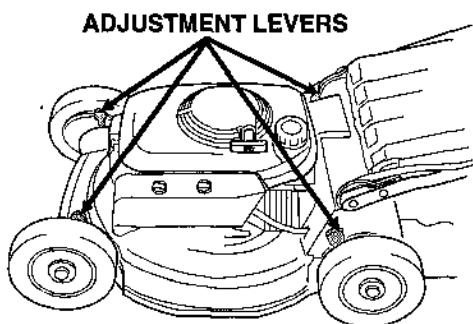

VB5CADA4 CDR

To adjust cutting height, pull each adjustment lever toward the wheel, and move it into another notch.

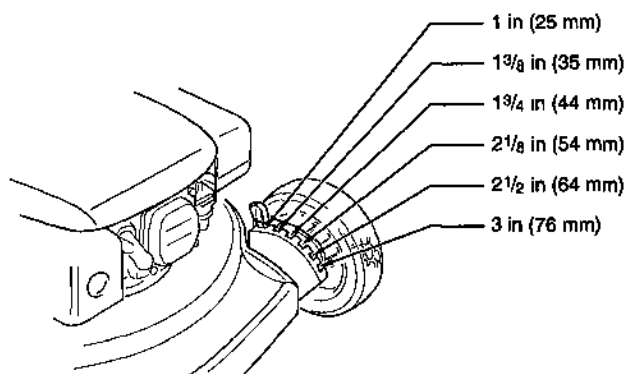

VB5CACA1 CDR

If you are not sure what cutting height to select, start with a high setting and check the appearance of the lawn after mowing a small area. Then readjust cutting height if necessary.

OPERATION

This chapter tells you how to operate the mower safely and effectively.

MOWING PRECAUTIONS	28
STARTING THE ENGINE	28
OPERATING THE CONTROLS FOR MOWING	30
Throttle Lever	30
Blade Control Lever	30
Drive Clutch Lever	31
Shift Lever	32
STOPPING THE ENGINE	33
SAFE MOWING PRACTICES	34
Slopes	34
Obstacles	35
Gravel and Loose Objects	35
MOWING TIPS	36
When to Mow	36
Cutting Height	36
Cutting Width	36
Blade Speed	37
Blade Sharpness	37
Dry Grass	37
Wet Grass	37
Fallen Leaves	37
Clogged Mower Deck	37
Mowing Patterns	38
Bagging	38
Side-Discharge Mowing	38
Mulching	38

OPERATION

MOWING PRECAUTIONS

Before operating the mower for the first time, please review the **IMPORTANT SAFETY INFORMATION** beginning on page 6 and the previous chapter, titled **BEFORE OPERATION**.

Even if you have operated other mowers, take time to become familiar with how this mower works and practice in a safe area until you build up your skills.

For your safety, avoid starting or operating the engine in an enclosed area such as a garage. Your mower's exhaust contains poisonous carbon monoxide gas which can collect rapidly in an enclosed area and cause illness or death.

STARTING THE ENGINE

Before starting, always release the blade control lever and drive clutch lever, so the blade will not turn, and the mower will not move forward, when you operate the starter.

1. Turn the fuel valve to the ON position.

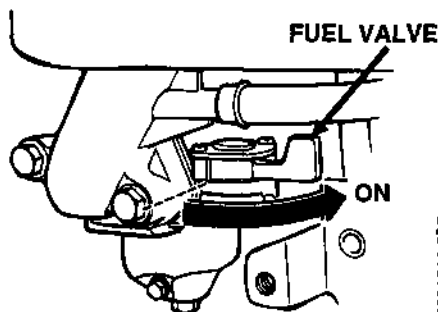

VB5CACA CDR

2. Move the throttle lever to the proper starting position.

COLD ENGINE:

Move the throttle lever to the **CHOKE** position.

WARM ENGINE:

Move the throttle lever to the **FAST** position.

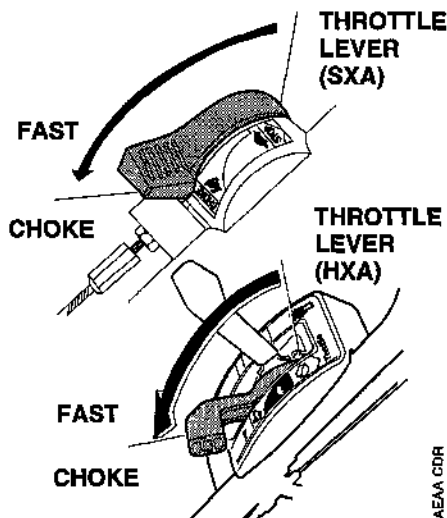

VB5CAEA CDR

- Place your foot on the mower deck step. Pull the starter grip lightly until you feel resistance, then pull briskly. Return the starter grip gently.

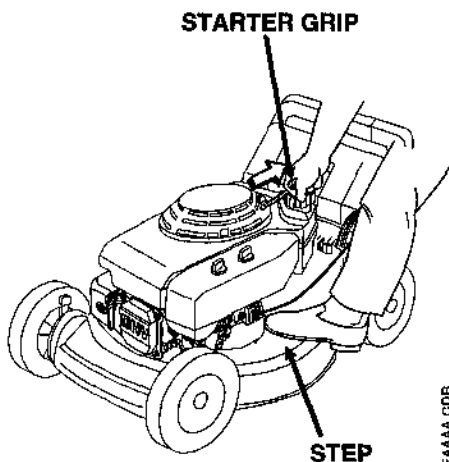

VB5EAAA CDR

- Move the throttle lever away from the CHOKE position as soon as the engine warms up enough to run smoothly without use of the choke. Set the throttle lever at FAST to mow or at SLOW to idle.

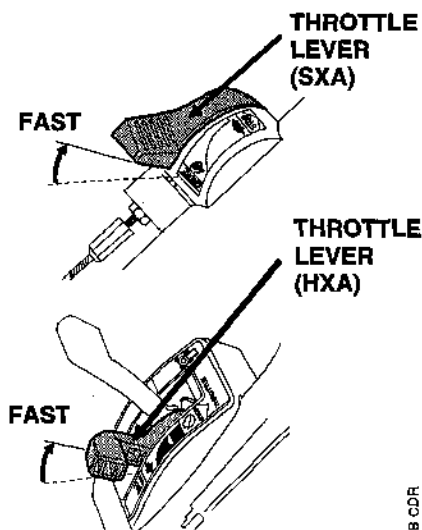

VB5CAEAB CDR

OPERATION

OPERATING THE CONTROLS FOR MOWING

Throttle Lever

For best cut quality, always mow with the throttle lever in the **FAST** position. When the blade rotates at the preset fast speed, it creates a strong fan action that lifts and cuts grass more efficiently. Do not try to increase the preset engine speed, the blade could fracture and come apart.

When you need to leave the mower for any reason, move the throttle lever to the stop position.

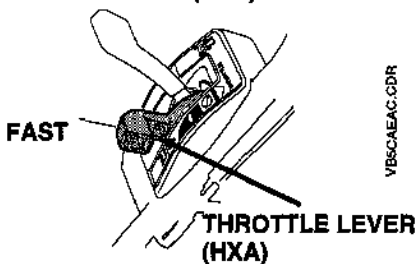
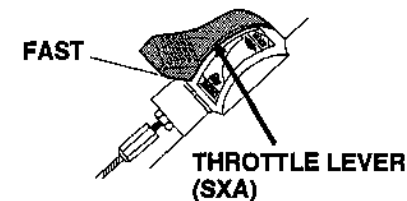

VBSCAEAC.GDR

Blade Control Lever

To start blade rotation, press the button on top of the blade control lever, then push the lever forward and hold it against the handlebar.

Release the blade control lever to stop the blade.

Operate the blade control lever with a quick and complete motion, so the blade control is always either fully engaged or stopped. This will help to prevent stalling the engine, and it will also extend the service life of the blade control mechanism.

Always release the blade control lever before starting the engine to prevent the blade from turning.

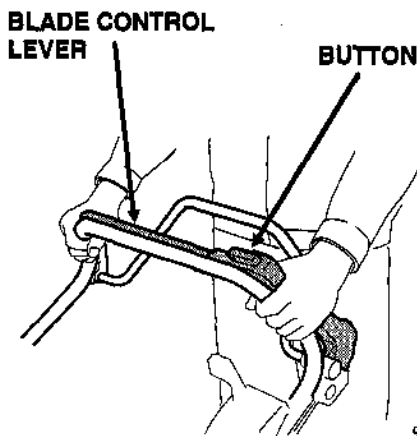

VASCACAA.GDR

Drive Clutch Lever

HRC216SXA

Push the drive clutch lever forward to propel the mower.

Release the drive clutch lever to stop the mower.

HRC216HXA

You can control self-propelled speed with the drive clutch lever. The mower will move gradually faster as you push the drive clutch lever forward. If you push the lever all the way forward to the handlebar, the mower will move at the speed determined by the shift lever setting (see page 32).

When moving and using the drive clutch lever to change self-propelled speed, continue to fully hold the blade control lever against the handlebar. This will help to extend the service life of the blade control mechanism.

All Models

For self-propelled mowing, press the button on top of the blade control lever, push the blade control lever forward, then push the drive clutch lever forward. The drive clutch lever can be used to hold the blade control lever against the handlebar.

Always release the drive clutch lever before starting the engine. If the drive clutch is engaged, the mower will move forward when you operate the starter.

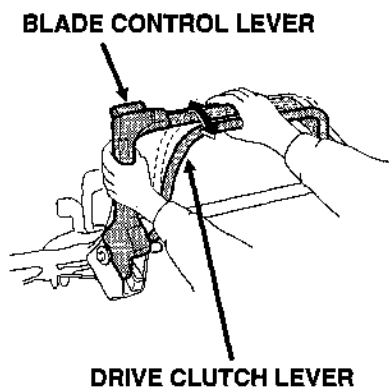

OPERATION

Shift Lever

HRC216SXA

With the drive clutch lever released, move the shift lever to select slow (1) or fast (2).

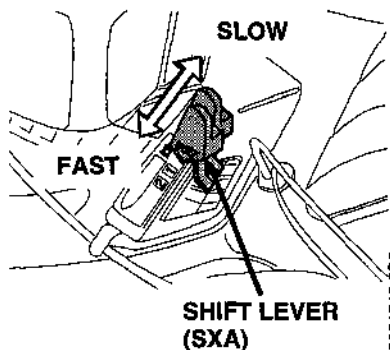

HRC216HXA

Move the shift lever to select the pace at which you normally mow in open areas.

If you wish to momentarily slow the mower during operation, partially release the drive clutch lever, then resume your normal speed by pushing the drive clutch lever forward again. It is not necessary to move the shift lever for momentary speed reduction.

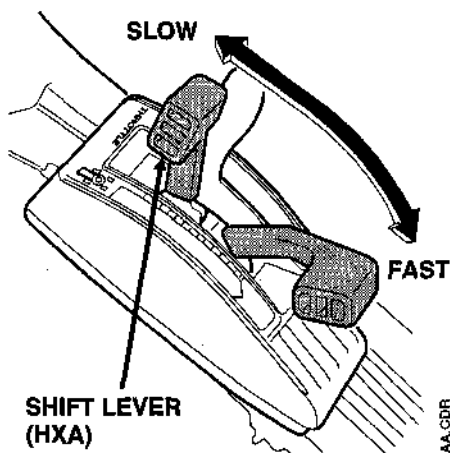

All Models

Do not use the throttle lever to adjust your forward speed. Forward speed should be adjusted with the shift lever, not the throttle lever. The throttle lever must remain in the FAST position for good mowing performance. Otherwise, cut quality suffers.

STOPPING THE ENGINE

1. Release the drive clutch lever and blade control lever.

2. Move the throttle lever to the STOP position.

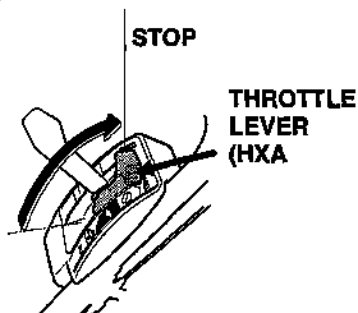
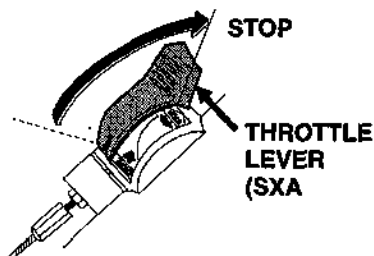

3. When the mower is not in use, turn the fuel valve to the OFF position.

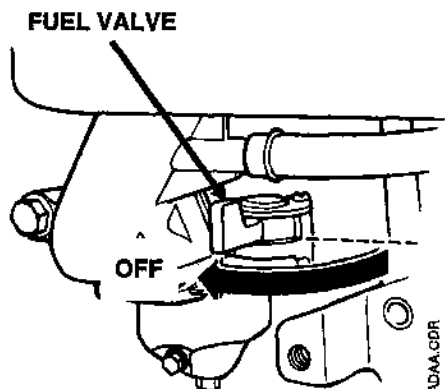

VBSCAFAA.CDR

VB5FADAA.CDR

OPERATION

SAFE MOWING PRACTICES

For your safety, keep all four wheels on the ground, and be careful to avoid losing your footing and your control of the mower. Keep a firm grip on the handlebar, and walk, never run, with the mower. Be very careful when mowing uneven or rough ground.

If the mower becomes stuck, do not kick or shove it with your foot. Use the handlebar to control the mower.

⚠ WARNING

The blade is sharp and spins at high speed.

A spinning blade can cut you severely and can amputate fingers and toes.

- Wear protective footwear.
- Keep your hands and feet away from the mower deck while the engine is running.
- Stop the engine before performing any adjustment, inspection, or maintenance.

Slopes

Mow across slopes, not up and down. Avoid steep slopes (more than 20°), and be careful when changing direction. Mowing on a slope when the grass is damp or wet could cause you to slip, fall, and lose control of the mower.

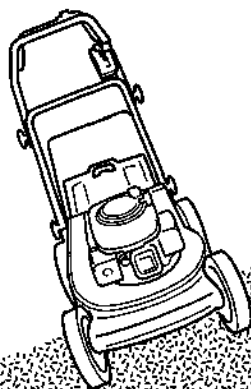

MAXIMUM SLOPE: 20°

Obstacles

Use the side of the mower to cut close to large obstacles, such as fences or walls.

Release the drive clutch lever to disengage the drive when mowing around trees and other obstacles. Push the mower around obstacles for better directional control. Be careful when mowing over obstacles embedded in the lawn, such as sprinkler heads, paving, edging, etc. Avoid anything that sticks up above the surface of the lawn.

If the blade hits something, or if the mower starts to vibrate, stop the engine immediately and check for damage. Striking objects may damage the blade, bend the crankshaft, and/or break the mower deck or other components. Vibration usually indicates serious trouble.

WARNING

A worn, cracked, or damaged blade can break, and pieces of the damaged blade can become dangerous projectiles.

Thrown objects can cause serious injury.

Inspect the blade regularly, and do not operate the mower with a worn or damaged blade.

The Distributor's Limited Warranty does not cover parts damaged by accident or collision.

Gravel and Loose Objects

Gravel, loose stones, and landscaping material can be picked up by the mower and thrown large distances with enough force to cause serious personal injury and/or property damage. The best way to prevent potential injury from thrown objects is to release the blade control lever to stop the blade before reaching areas with gravel, loose stones, or landscaping material.

OPERATION

MOWING TIPS

When to Mow

Most grasses should be mowed when they have grown $\frac{1}{2}$ to 1 inch above their recommended height.



Cutting Height

Consult a local nursery or lawn and garden center for cutting height recommendations and advice about specific types of grasses and growing conditions in your area.

If you look closely, you'll see that most grass has stems and leaves. If you cut off the leaves, you'll scalp the lawn. Let the grass recover between mowings. Your mower will work better, and your lawn will look better.



TOO SHORT

LM-AAFAA.TIF



LONG ENOUGH

LM-AAGAA.TIF

If your grass gets too tall, cut it once at the highest cutting height setting, then mow again in 2 or 3 days. Don't take off more than one third of total grass height in any one mowing, or brown patches may develop.

Cutting height adjustment is explained on page 17.

Cutting Width

For an even lawn finish, overlap each mowing swath by a few inches. If the grass is very tall or thick, use more overlap and a narrower mowing swath.

Blade Speed

The blade must spin very fast to cut properly. Always use the FAST throttle setting, and keep the engine running at maximum rpm.

If engine speed drops, it could mean the engine is being overloaded by the blade trying to cut too much grass. Mow a narrower swath, move the mower slower, or raise the cutting height.

Blade Sharpness

A sharp blade cuts cleanly. A dull blade tears the grass, leaving shredded ends that turn brown. When your blade doesn't cut cleanly anymore, have it sharpened or replaced.

Dry Grass

If the ground is too dry, mowing will stir up a lot of dust. Besides being unpleasant to work in, too much dust will clog the carburetor air filter.

If dust is a problem, water your lawn the day before mowing. Mow when the grass is dry to your touch, but the soil is still moist.

Wet Grass

Wet grass is slippery and can make you lose your footing. Also, wet grass clippings will clog the mower deck and collect in clumps on the lawn. Always wait for wet grass to dry before mowing.

Fallen Leaves

Your mower can be used to pick up fallen leaves for disposal. If using the mower to bag large amounts of fallen leaves, and not for mowing, set the cutting height adjustment levers so the front of the mower deck is one or two settings higher than the rear.

Clogged Mower Deck

Before clearing a clogged mower deck, stop the engine and turn the fuel valve OFF. With the spark plug cap disconnected, tilt the mower so the carburetor side is up.

Clear a clogged deck with a stick, not your hands.

OPERATION

Mowing Patterns

Your Honda mower will work most efficiently if you use the following mowing patterns as much as possible. Mower deck and equipment design, and the direction in which the blade rotates, cause these mowing patterns to give the best results.

If the lawn has an irregular shape, or many obstacles, divide it into sections where you can use the recommended mowing pattern.

Bagging

Use a clockwise mowing pattern. This will give the best bagging performance, leaving the least amount of clippings on the lawn.

Side-Discharge Mowing

(requires optional side-discharge chute)

Where possible, use the same mowing pattern recommended for bagging. If the lawn has an irregular shape, or many obstacles, divide it into sections where clippings will be discharged away from uncut areas. This will prevent clippings from piling up in the path of the mower.

Mulching

(requires optional mulching kit)

Use a counterclockwise mowing pattern. The optional mulching kit includes instructions. Refer to the instructions for mulching recommendations.

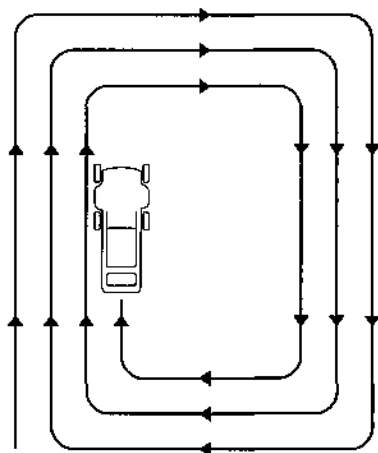

BAGGING & SIDE-DISCHARGE PATTERN

LM-AAHAA.CDR

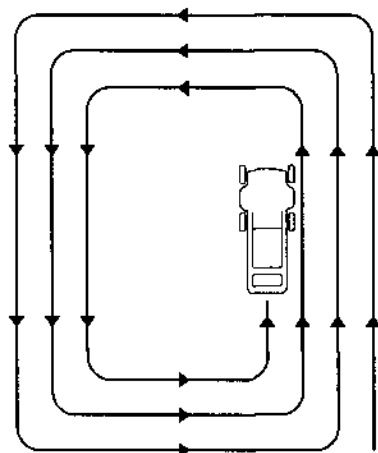

MULCHING PATTERN

LM-AAHVA.CDR

TRANSPORTING

This chapter explains how to load and carry your mower safely.

BEFORE LOADING	40
LOADING AND UNLOADING	40

TRANSPORTING

BEFORE LOADING

If the engine has been running, allow it to cool for at least 15 minutes before loading the mower on the transport vehicle. A hot engine and exhaust system can burn you and can ignite some materials.

1. Remove the grass bag.
2. Put the throttle lever in the STOP position.

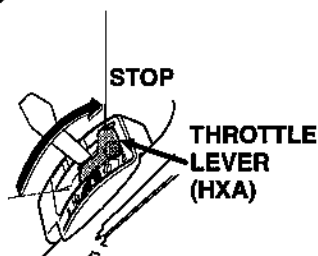
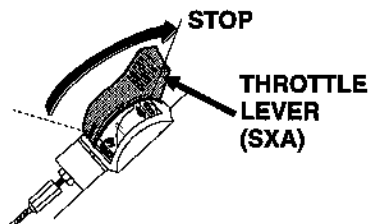

3. Move the fuel valve to the OFF position. This will prevent carburetor flooding and reduce the possibility of fuel leakage.

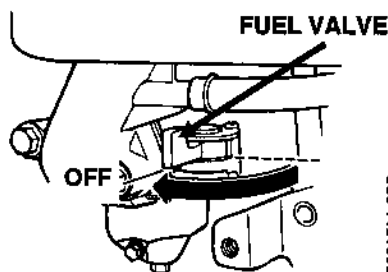

LOADING AND UNLOADING

If a suitable loading ramp is not available, two people should lift the mower on and off the transport vehicle while holding the mower level.

Position the mower so all four wheels are on the bed of the transport vehicle. Tie the mower down with rope or straps, and block the wheels. Keep the tie-down rope or straps away from the controls, adjustment levers, cables, and the carburetor.

VBSCAFAM.CDR

VBSCAFAM.CDR

MAINTENANCE

This chapter explains when and how to perform routine inspection, service, and adjustments for do-it-yourself maintenance. More difficult maintenance tasks should be done by your dealer. Your dealer is best equipped and staffed to provide the level of service and safety you and your mower deserve.

THE IMPORTANCE OF MAINTENANCE	42
MAINTENANCE SAFETY	43
Safety Precautions	43
EMISSION CONTROL SYSTEM INFORMATION	44
Source of Emissions	44
The U.S. and California Clean Air Acts	44
Tampering and Altering	44
Problems That May Affect Emissions	44
Replacement Parts	45
Maintenance	45
MAINTENANCE SCHEDULE	46
ENGINE MAINTENANCE	47
Engine Oil Change	47
Engine Oil Recommendations	48
Air Cleaner Service	49
Spark Plug Service	50
Carburetor Adjustment	52
Carburetor Modification For High Altitude Operation . . .	52
Fuel Recommendations	53
CONTROL CABLE ADJUSTMENTS	54
Blade Control Cable Adjustment	54
Drive Clutch Cable Adjustment	55
THROTTLE CABLE INSPECTION	58
BLADE REMOVAL AND INSTALLATION	59
Blade Removal	59
Blade Installation	60
GRASS BAG CLEANING AND REPLACEMENT	61

MAINTENANCE

THE IMPORTANCE OF MAINTENANCE

Good maintenance is essential for safe, economical and trouble-free operation. It will also help reduce pollution.

WARNING

Improper maintenance, or failure to correct a problem before operation, can cause a malfunction in which you can be seriously hurt or killed.

Always follow the inspection and maintenance recommendations and schedules in this owner's manual.

To help you properly care for your engine, the following pages include a maintenance schedule, routine inspection procedures, and simple maintenance procedures using basic hand tools. Other service tasks that are more difficult, or require special tools, are best handled by professionals and are normally performed by a Honda technician or other qualified mechanic.

The maintenance schedule applies to normal operating conditions. If you operate your mower under severe conditions, such as sustained high-load or high-temperature operation, or use in unusually wet or dusty conditions, consult your servicing dealer for recommendations applicable to your individual needs and use.

Maintenance, replacement, or repair of the emission control devices and systems may be performed by any engine repair establishment or individual, using parts that are "certified" to EPA standards.

MAINTENANCE SAFETY

Some of the most important safety precautions follow. However, we cannot warn you of every conceivable hazard that can arise in performing maintenance. Only you can decide whether or not you should perform a given task.

⚠ WARNING

Failure to properly follow maintenance instructions and precautions can cause you to be seriously hurt or killed.

Always follow the procedures and precautions in this owner's manual

Safety Precautions

- Make sure the engine is off before you begin any maintenance or repairs. This will eliminate several potential hazards:
 - **Carbon monoxide poisoning from engine exhaust.**
Be sure there is adequate ventilation whenever you operate the engine.
 - **Burns from hot parts.**
Let the engine and exhaust system cool before touching.
 - **Injury from moving parts.**
Do not run the engine unless instructed to do so.
- Read the instructions before you begin, and make sure you have the tools and skills required.
- To reduce the possibility of fire or explosion, be careful when working around gasoline. Use only a nonflammable solvent, not gasoline, to clean parts. Keep cigarettes, sparks and flames away from all fuel related parts.

Remember that an authorized Honda servicing dealer knows your lawn mower best and is fully equipped to maintain and repair it.

To ensure the best quality and reliability, use only new genuine Honda parts or their equivalents for repair and replacement.

EMISSION CONTROL SYSTEM INFORMATION

Source of Emissions

The combustion process produces carbon monoxide, oxides of nitrogen, and hydrocarbons. Control of hydrocarbons and oxides of nitrogen is very important because, under certain conditions, they react to form photochemical smog when subjected to sunlight. Carbon monoxide does not react in the same way, but it is toxic.

Honda utilizes lean carburetor settings and other systems to reduce the emissions of carbon monoxide, oxides of nitrogen, and hydrocarbons.

The U.S. and California Clean Air Acts

EPA and California regulations require all manufacturers to furnish written instructions describing the operation and maintenance of emission control systems.

The following instructions and procedures must be followed in order to keep the emissions from your Honda engine within the emission standards.

Tampering and Altering

Tampering with or altering the emission control system may increase emissions beyond the legal limit. Among those acts that constitute tampering are:

- Removal or alteration of any part of the intake, fuel, or exhaust systems.
- Altering or defeating the governor linkage or speed-adjusting mechanism to cause the engine to operate outside its design parameters.

Problems That May Affect Emissions

If you are aware of any of the following symptoms, have your engine inspected and repaired by your servicing dealer.

- Hard starting or stalling after starting.
- Rough idle.
- Misfiring or backfiring under load.
- Afterburning (backfiring).
- Black exhaust smoke or high fuel consumption.

Air Index

An Air Index Information hang tag/label is applied to engines certified to an emission durability time period in accordance with the requirements of the California Air Resources Board.

The bar graph is intended to provide you, our customer, the ability to compare the emissions performance of available engines. The lower the Air Index, the less pollution.

The durability description is intended to provide you with information relating the engine's emission durability period. The descriptive term indicates the useful life period for the engine's emission control system. See your *Emission Control System Warranty* for additional information.

Descriptive Term	Applicable to Emissions Durability Period
Moderate	50 hours (0-65 cc) 125 hours (greater than 65 cc)
Intermediate	125 hours (0-65 cc) 250 hours (greater than 65 cc)
Extended	300 hours (0-65 cc) 500 hours (greater than 65 cc)

The Air Index Information hang tag/label must remain on the mower until it is sold. Remove the hang tag before operating the mower.

Replacement Parts

The emission control systems on your new Honda engine were designed, built, and certified to conform with EPA and California emission regulations. We recommend the use of genuine Honda parts whenever you have maintenance done. These original-design replacement parts are manufactured to the same standards as the original parts, so you can be confident of their performance. The use of replacement parts that are not of the original design and quality may impair the effectiveness of your emission control system.

A manufacturer of an aftermarket part assumes the responsibility that the part will not adversely affect emission performance. The manufacturer or rebuilder of the part must certify that use of the part will not result in a failure of the engine to comply with emission regulations.

Maintenance

Follow the maintenance schedule on page 46. Remember that this schedule is based on the assumption that your machine will be used for its designed purpose. Sustained high-load or high-temperature operation, or use in unusually wet or dusty conditions, will require more frequent service.

MAINTENANCE

MAINTENANCE SCHEDULE

ITEM	REGULAR SERVICE PERIOD (3) Perform at every indicated interval	Before Each Use	Every Year or 20 Hours	Every 50 Hours	Every 100 Hours	Every 300 Hours	Refer to Page	
Blade condition and blade bolt tightness	Check	○					21 60	
Engine oil	Check	○					22	
	Change		○		○		47	
Air cleaner	Check	○					24	
	Clean			○ ¹			49	
	Replace					○* ¹		
Grass bag	Check	○					25	
Spark plug	Clean-adjust				○		50	
	Replace					○		
Idle speed	Check-adjust					○ ²	52	
Blade control cable	Adjust		○		○		54	
Drive clutch cable	SXA Adjust		○		○		55	
	HXA						56	
Spark arrester (optional equipment)	Clean-inspect				○		81	
Blade control mechanism	Check		○ ²		○ ²		—	
Throttle cable	Adjust		○ ²		○ ²		—	
Valve clearance	Adjust					○ ²	—	
Combustion chamber	Clean	After every 300 hours (2)						—
Fuel tank	Clean					○ ²	—	
Fuel line	Replace	Every 2 years ²						—

* Replace the paper filter only.

¹ Service more frequently when used in dusty areas.

² These items should only be serviced by an authorized Honda servicing lawn mower dealer, unless you are mechanically proficient and have the proper tools. Refer to the Honda shop manual for service procedures.

³ For commercial use, log hours of operation to determine proper maintenance intervals.

ENGINE MAINTENANCE

Engine Oil Change

Drain the used oil while the engine is warm. Warm oil drains quickly and completely.

1. Put the throttle lever in the STOP position. Turn the fuel valve to the OFF position. This will reduce the possibility of fuel leakage (see page 33).
2. Wipe the oil filler area clean, then remove the oil filler cap/dipstick.
3. Place a suitable container next to the mower to catch the used oil, then tilt the mower on its right side. The used oil will drain through the oil filler neck. Allow the oil to drain completely.

Please dispose of used motor oil and the containers in a manner that is compatible with the environment. We suggest you take it in a sealed container to your local recycling center or service station for reclamation. Do not throw it in the trash, pour it on the ground or down a drain.

4. Fill with the recommended oil. Do not overfill; check the oil level as shown on page 48.

Engine oil capacity:
0.69 US qt (0.65 ℓ).

NOTICE

Using nondetergent oil can shorten the engine's service life, and using 2-stroke oil can damage the engine.

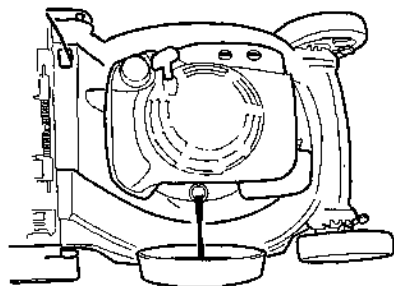

VB5EABAA CDR

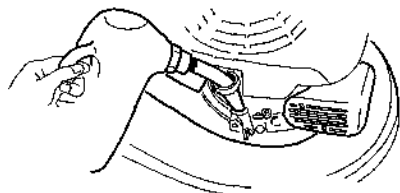

VEZEADAB CDR

MAINTENANCE

5. After changing the engine oil, and before starting the engine, check the oil level with the mower on a level surface:

- Wipe the dipstick clean.
- Insert and remove the dipstick without screwing it into the filler neck. Check the oil level shown on the dipstick.
- If the oil level is low, add oil to reach the upper limit mark on the dipstick. Do not overfill. If the engine is overfilled, the excess oil may get transferred to the air cleaner housing and air cleaner elements.

NOTICE

Running the engine with a low oil level can cause engine damage.

- Screw in the filler cap/dipstick securely.

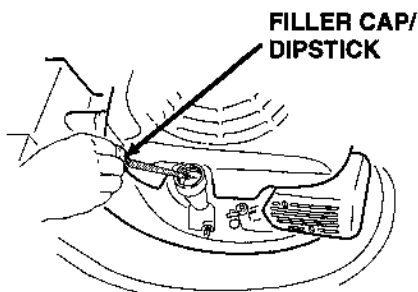

VEZEAAAB CDR

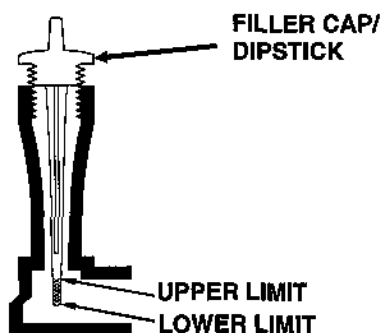

LM-ANDAAB CDR

Engine Oil Recommendations

Oil is a major factor affecting performance and service life. Use 4-stroke automotive detergent oil.

SAE 10W-30 is recommended for general use. Other viscosities shown in the chart may be used when the average temperature in your area is within the recommended range.

The SAE oil viscosity and service classification are in the API label on the oil container. Honda recommends that you use API SERVICE category SH or SJ oil with the ILSAC "starburst" certification mark displayed on the container.

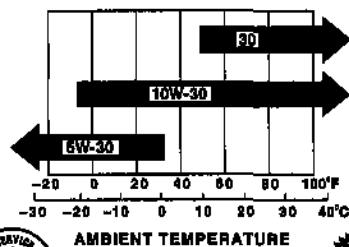

Air Cleaner Service

A dirty air filter will restrict air flow to the carburetor, reducing engine performance. If you operate the mower in very dusty areas, clean the air filter more often than specified in the MAINTENANCE SCHEDULE.

NOTICE

Operating the engine without an air filter, or with damaged elements, will allow dirt to enter the engine, causing rapid engine wear. This type of damage is not covered by the Distributor's Limited Warranty.

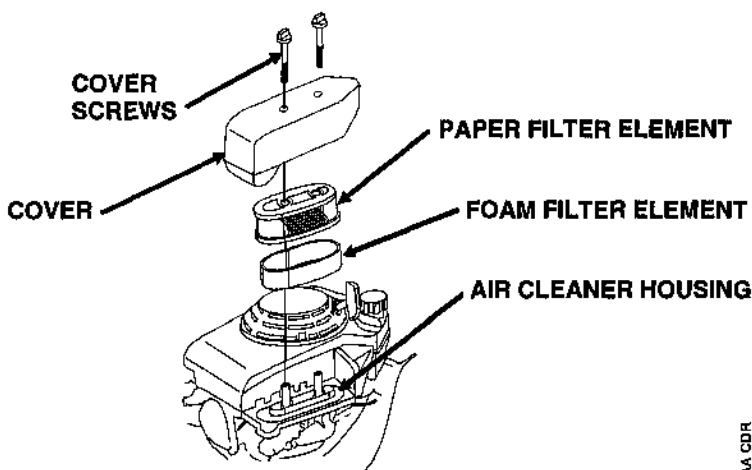

1. Unscrew and remove the air cleaner cover screws, then remove the air cleaner cover.
2. Remove the air filter and separate the filter elements.
3. Inspect the elements for holes, tears, or other damage, and replace them if they are damaged.
4. Clean the elements.

Paper element: Tap the element several times on a hard surface to remove dirt, or blow compressed air [not exceeding 30 psi (207 kPa)] through the element from the inside. Never try to brush off dirt; brushing will force dirt into the fibers.

MAINTENANCE

Foam element: Clean it in warm soapy water, rinse, and allow it to dry thoroughly. Or clean it in nonflammable solvent and allow it to dry. Dip the filter in clean engine oil and squeeze out all excess oil.

NOTICE

Excess oil will restrict air flow through the foam element and may transfer to the paper element, soaking and clogging it.

5. Wipe dirt from the inside of the air cleaner housing and cover, using a moist rag. Be careful to prevent dirt from entering the air duct that leads to the carburetor.
6. Reinstall the filter and cover. Tighten the cover screws securely.

Spark Plug Service

RECOMMENDED SPARK PLUGS	REGULAR	RESISTOR*
NGK	BP5ES	BPR5ES
DENSO	W16EP-U	W16EPR-U
CHAMPION	N12Y	RN12Y

* Resistor spark plugs reduce interference with radio and TV reception.

NOTICE

Incorrect spark plugs can cause engine damage.

For good performance, the spark plug must be properly gapped and free of deposits.

1. Disconnect the spark plug cap, and remove any dirt from around the spark plug area.

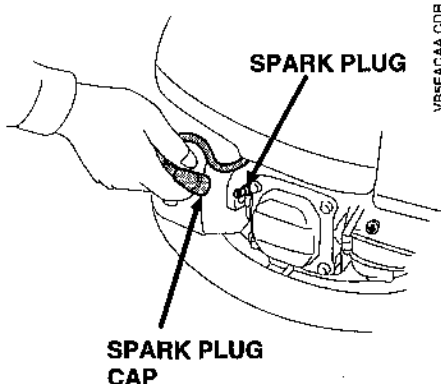

- Remove the spark plug with a $\frac{13}{16}$ in (21 mm) spark plug wrench.
 - Inspect the spark plug. Replace it if the electrodes are worn, or if the insulator is cracked or chipped. Clean the spark plug with a wire brush if you are going to reuse it.
 - Measure the spark plug electrode gap with a suitable gauge. The gap should be 0.028 ~ 0.031 in (0.7 ~ 0.8 mm). Correct the gap, if necessary, by carefully bending the side electrode.
 - Install the spark plug carefully, by hand, to avoid cross-threading.
 - After the spark plug seats, tighten with a $\frac{13}{16}$ in (21 mm) spark plug wrench to compress the washer.
- If reinstalling the old spark plug, tighten $\frac{1}{8}$ to $\frac{1}{4}$ turn after the spark plug seats.
- If installing a new spark plug, tighten $\frac{1}{2}$ turn after the spark plug seats to compress the washer.

NOTICE

A loose spark plug can overheat and damage the engine. Overtightening the spark plug can damage the threads in the cylinder head.

- Install the spark plug cap on the spark plug.

SPARK PLUG WRENCH

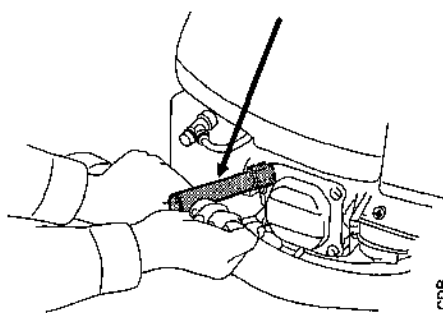

VB5EA00A CDR

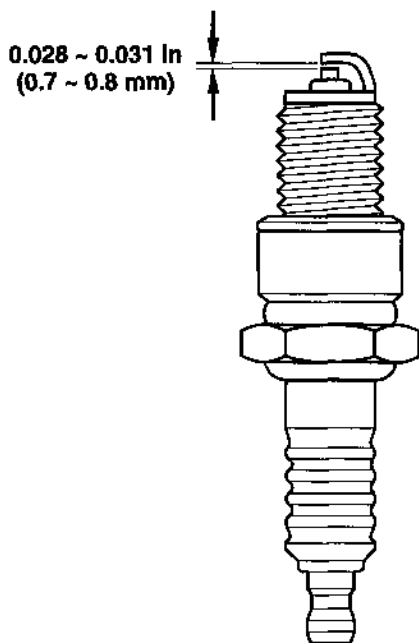

LM-A000A CDR

MAINTENANCE

Carburetor Adjustment

1. Start the engine outdoors, and allow it to warm up to normal operating temperature.
2. Set the throttle lever in the SLOW position.
3. Turn the throttle stop screw to obtain the standard idle speed.

Standard idle speed:
1,700 ± 150 rpm

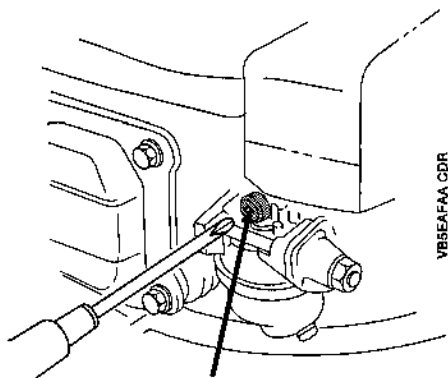

VB5EFAA GDR

THROTTLE STOP SCREW

Carburetor Modification For High Altitude Operation

At high altitude, the standard carburetor air-fuel mixture will be too rich. Performance will decrease, and fuel consumption will increase. A very rich mixture will also foul the spark plug and cause hard starting.

High altitude performance can be improved by specific modifications to the carburetor. If you always operate your mower at altitudes above 6,000 feet (1,800 meters) have an authorized Honda servicing dealer perform this carburetor modification.

Even with carburetor modification, engine horsepower will decrease about 3.5% for each 1000-foot (300-meter) increase in altitude. The effect of altitude on horsepower will be greater than this if no carburetor modification is made.

NOTICE

When the carburetor has been modified for high altitude operation, the air-fuel mixture will be too lean for low altitude use. Operation at altitudes below 6,000 feet (1,800 meters) with a modified carburetor may cause the engine to overheat and result in serious engine damage. For use at low altitudes, have an authorized Honda servicing dealer return the carburetor to original factory specifications.

Fuel Recommendations

Use unleaded gasoline with a pump octane rating of 86 or higher.

This engine is certified to operate on unleaded gasoline. Unleaded gasoline produces fewer engine and spark plug deposits and extends exhaust system life.

Never use stale or contaminated gasoline or an oil/gasoline mixture. Avoid getting dirt or water in the fuel tank.

Occasionally you may hear light "spark knock" or "pinging" (metallic rapping noise) while operating under heavy loads. This is no cause for concern.

If spark knock or pinging occurs at a steady engine speed, under normal load, change brands of gasoline. If spark knock or pinging persists, see your servicing dealer.

NOTICE

Running the engine with persistent spark knock or pinging can cause engine damage.

Running the engine with persistent spark knock or pinging is misuse, and the Distributor's Limited Warranty does not cover parts damaged by misuse.

For oxygenated fuel information refer to page 80.

MAINTENANCE

CONTROL CABLE ADJUSTMENTS

Blade Control Cable Adjustment

Measure free play at the top of the lever, while holding the button down. Free play should be $\frac{3}{4}$ ~ 1 in (20 ~ 25 mm). If adjustment is necessary:

1. Loosen the lock nuts with a 10 mm wrench, and move the adjuster up or down as required.
2. Tighten the lock nuts and recheck free play.
3. Start the engine outdoors, and operate the blade control lever. Check that the blade starts when you push the lever forward and stops quickly when you release the lever.

If the blade does not start or stop as it should, with correct cable adjustment, take the mower to an authorized Honda servicing dealer for repair.

$\frac{3}{4}$ ~ 1 in
(20 ~ 25 mm)

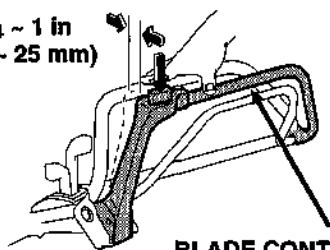

BLADE CONTROL LEVER

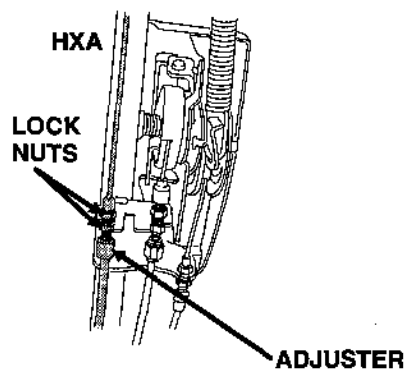

VBSCAAA.CDR

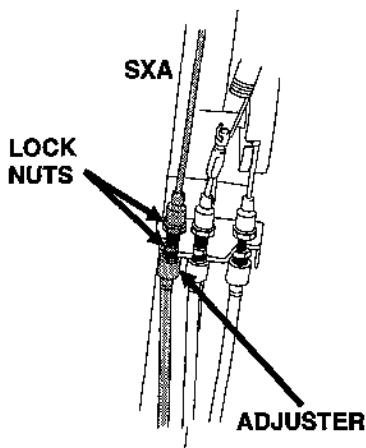

VASCAMAA.CDR

VBSCAHAA.CDR

Drive Clutch Cable Adjustment HRC216SXA

1. Measure the free play at the top of the drive clutch lever, as shown. Free play should be $\frac{3}{16} \sim \frac{3}{8}$ in (5 ~ 10 mm).

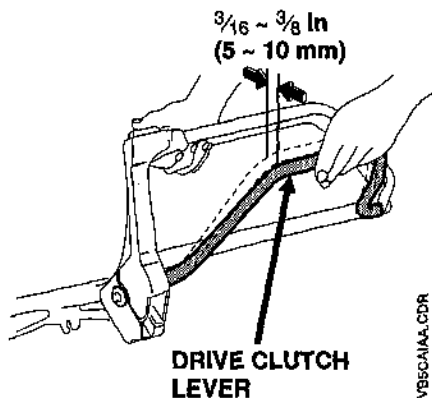

VBSCA1AA.CDR

2. If adjustment is necessary, loosen the lock nuts with a 10 mm wrench, and move the adjuster up or down as required. Tighten the lock nuts and recheck free play.
3. Start the engine and operate the drive clutch lever. Check to be sure the drive clutch engages and releases properly. If the drive clutch does not operate properly, and lever free play is correctly adjusted, take the mower to an authorized Honda servicing dealer for repair.

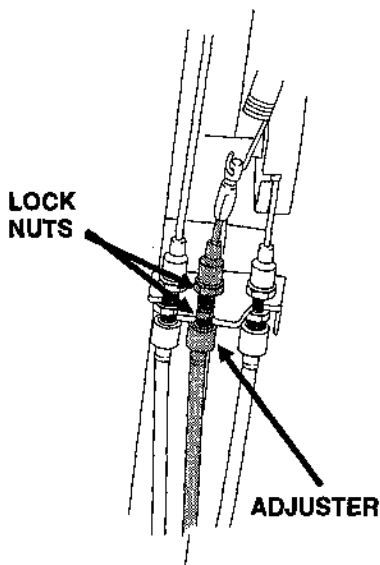

VBSCA1AB.CDR

MAINTENANCE

HRC216HXA

1. Remove the grass bag and raise the discharge guard.
2. Remove the screw from the transmission cover plate, and remove the cover plate.
3. Set the rear cutting height adjusters in the highest cutting height position (see page 17).

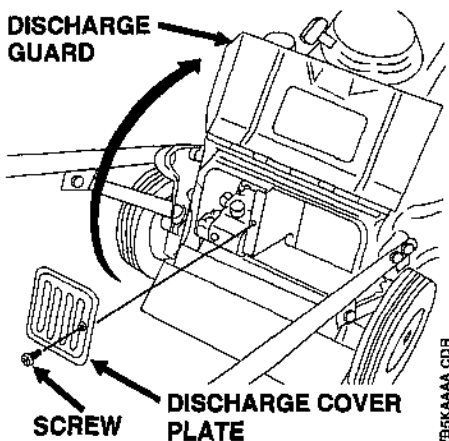

4. Move the shift lever to the slowest position.

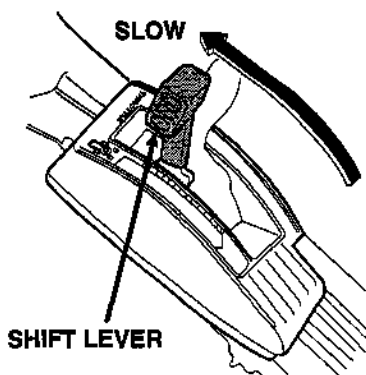

5. Push the drive clutch lever all the way forward, and hold it against the handlebar.

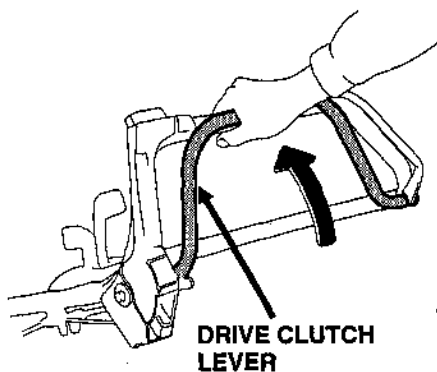

6. While holding the drive clutch lever all the way forward, look through the cover plate hole, and check the position of the control arm.

The center of the notch on the control arm should align with the index mark on the transmission case.

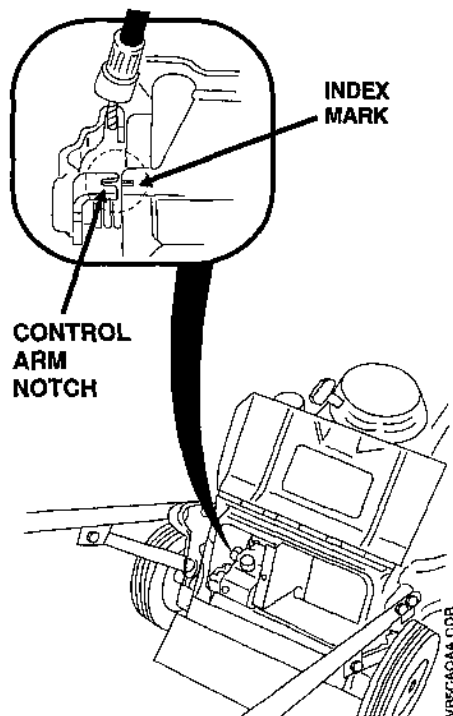

7. If adjustment is necessary, loosen the drive clutch cable lock nuts with a 10 mm wrench, and move the adjuster up or down as required. Tighten the lock nuts. Operate the clutch lever several times, and recheck control arm alignment.

8. After the control arm is precisely aligned, start the engine and operate the drive clutch lever. Check to be sure the drive clutch lever operates properly.

If the drive clutch lever does not operate properly after the cable is correctly adjusted, take the mower to an authorized Honda servicing dealer for repair.

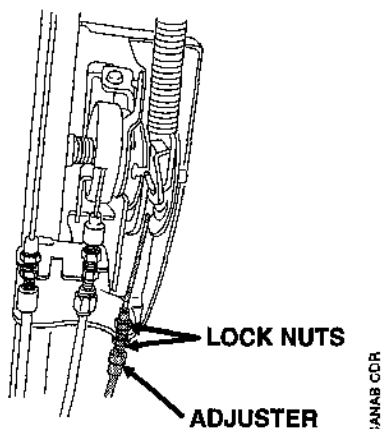

THROTTLE CABLE INSPECTION

Throttle cable adjustment is necessary if the throttle lever does not operate the choke properly.

You can inspect choke operation by observing the movement of the choke arm, which is located on top of the carburetor.

1. Move the throttle lever to the **CHOKE** position. The choke arm should move counterclockwise, until it contacts the stop post on the carburetor.

Push the choke arm with your finger to verify that it has moved as far as it will go.

2. Move the throttle lever to the **FAST** position. The choke arm should move clockwise, until it contacts the stop post on the carburetor.

Push the choke arm with your finger to verify that it has moved as far as it will go.

3. If the choke arm does not move all the way to its stop, in either direction, take the mower to an authorized Honda servicing dealer. Throttle cable adjustment involves related control plate adjustments.

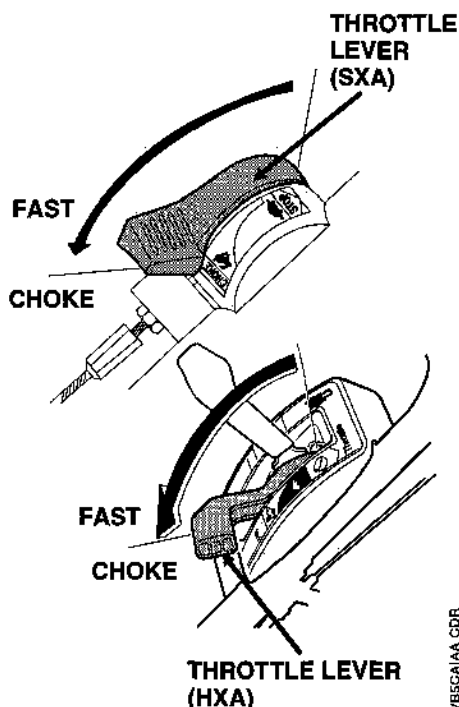

VB5GA/AA CDR

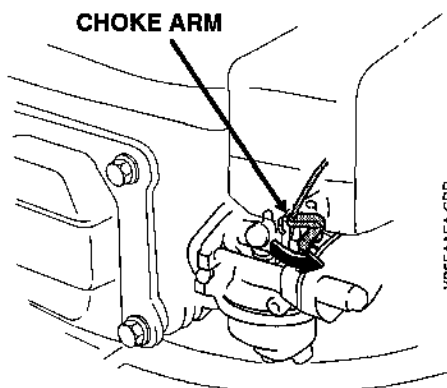

VB5FAAE CDR

BLADE REMOVAL AND INSTALLATION

If you remove the blade for sharpening or replacement, you will need a torque wrench for installation. Wear heavy gloves to protect your hands.

BLADE SHARPENING: To avoid weakening the blade, or causing imbalance or poor cutting, the blade should be sharpened by trained staff at your servicing dealer.

BLADE REPLACEMENT: Use a genuine Honda replacement blade or its equivalent.

Blade Removal

1. Put the throttle lever in the STOP and the fuel valve in the OFF positions. Disconnect the spark plug cap then tilt the mower to the right side, so the carburetor side is up. This will help to prevent fuel leakage and hard starting due to carburetor flooding.
2. Remove the two blade bolts with a 14 mm socket wrench. Use a wooden block to prevent the blade from turning when removing the bolts.
3. Remove the blade and blade holder from the blade control assembly.

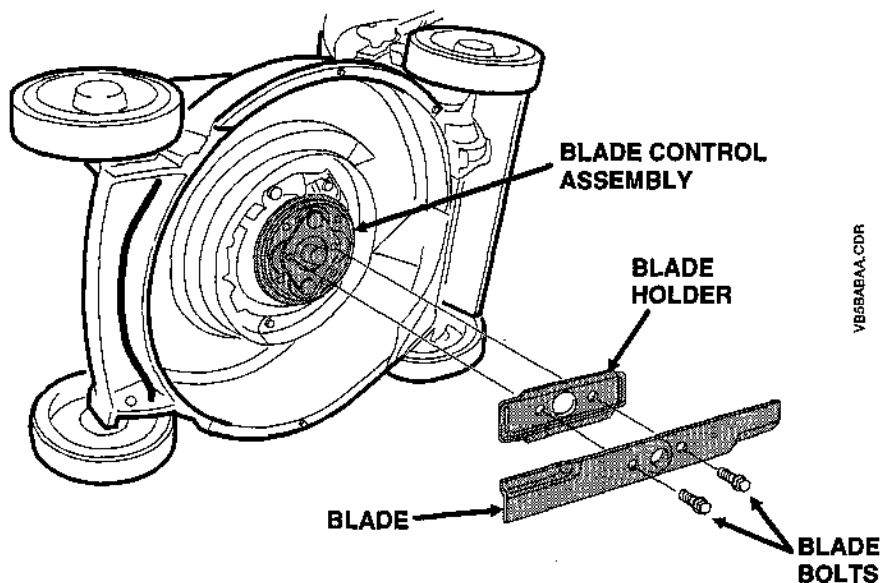

VB55ABAA, CDR

MAINTENANCE

Blade Installation

1. Clean dirt and grass from around the blade mounting area.
2. Install the blade and blade holder using the two blade bolts as shown.

The lift edge must be toward the engine.

The blade bolts are specially designed for this application and must not be replaced with other bolts.

3. Tighten the blade bolts with a torque wrench. Use a wooden block to prevent the blade from turning when tightening the bolts.

Blade bolt torque: 36 ~ 43 ft-lb
(49 ~ 59 N·m; 5.0 ~ 6.0 kg-m)

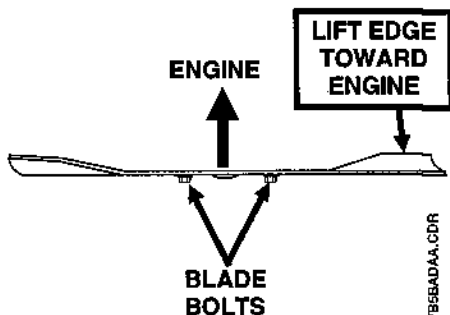
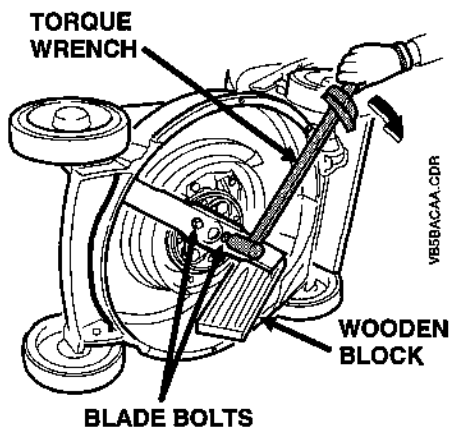

If you do not have a torque wrench, have your servicing dealer tighten the blade bolts before you use the mower. If the blade bolts are overtightened, they could break. If the blade bolts are not tightened enough, they could loosen or come out. In either case, it would be possible for the blade to fly off while you are operating the mower.

GRASS BAG CLEANING AND REPLACEMENT

Grass Bag Cleaning

Wash the bag with a garden hose, and allow it to dry completely before use; a wet bag will clog quickly.

Grass Bag Replacement

Replace a worn or damaged bag with a Honda replacement bag or its equivalent.

Bag Removal

1. Unclip the plastic edges of the bag from the frame.
2. Remove the bag from the frame.

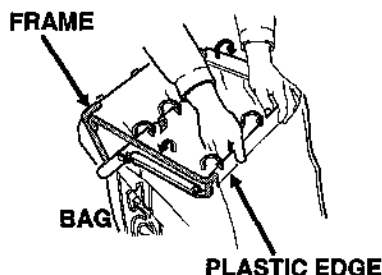

VAS9GABA CDR

Bag Installation

1. Insert the bag frame into the bag, as shown.
2. Clip the plastic edges of the bag onto the frame, as shown.

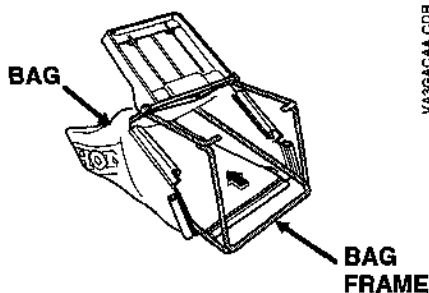

VAS9GACA CDR

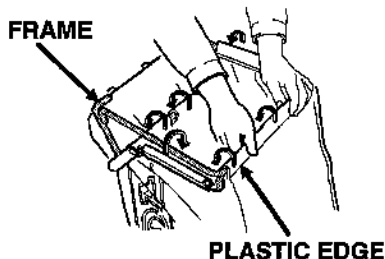

VAS9GAB CDR

TROUBLESHOOTING

This chapter shows what to check if you have a problem with your mower.

ENGINE PROBLEMS.....	64
Engine will not start.....	64
Loss of power	64
VIBRATION PROBLEMS.....	65
MOWING AND BAGGING PROBLEMS.....	65

TROUBLESHOOTING

ENGINE PROBLEMS

Engine Will Not Start	Possible Cause	Correction
1. Check control positions.	Fuel valve OFF.	Turn fuel valve ON (p. 14).
	Throttle lever in wrong position.	Move throttle lever to CHOKE position, unless the engine is warm (p. 28).
2. Check fuel.	Out of fuel.	Refuel (p. 23).
	Bad fuel; mower stored without treating or draining gasoline, or refueled with bad gasoline.	Drain fuel tank and carburetor (p. 70). Refuel with fresh gasoline (p. 23).
3. Remove and inspect spark plug.	Spark plug faulty, fouled, or improperly gapped.	Clean, gap, or replace spark plug (p. 51).
	Spark plug wet with fuel (flooded engine).	Dry and reinstall spark plug. Start engine with throttle lever in FAST position.
4. Take mower to an authorized Honda servicing dealer, or refer to shop manual.	Fuel filter clogged, carburetor malfunction, ignition malfunction, valves stuck, etc.	Replace or repair components as necessary.

Loss of Power	Possible Cause	Correction
1. Check throttle position.	Throttle not set to FAST.	Move throttle to FAST (p. 30).
2. Check grass height.	Grass too tall to cut.	Raise cutting height (p. 17), cut narrower swath (p. 36), or cut more frequently.
3. Check under mower deck.	Mower deck clogged.	Clean out mower deck (p. 37).
4. Check air filter.	Air filter clogged.	Clean or replace air filter (p. 49).
5. Check fuel.	Bad fuel; mower stored without treating or draining gasoline, or refueled with bad gasoline.	Drain fuel tank and carburetor (p. 70). Refuel with fresh gasoline (p. 23).
6. Take mower to an authorized Honda servicing dealer, or refer to shop manual.	Fuel filter clogged, carburetor malfunction, ignition malfunction, valves stuck, etc.	Replace or repair components as necessary.

VIBRATION PROBLEMS

Excessive Vibration	Possible Cause	Correction
1. Check mower deck and blade.	Grass and debris lodged under mower deck.	Clean out mower deck (p. 37).
	Blade loose, bent, damaged, or unbalanced by improper sharpening.	Tighten loose blade bolts. Replace damaged blade (p. 59 - 60).
2. Take mower to an authorized Honda servicing dealer for repair.	Mechanical damage, such as a bent crankshaft.	Replace or repair components as necessary.

MOWING AND BAGGING PROBLEMS

Poor Cut Quality or Poor Mowing/Bagging Performance	Possible Cause	Correction
1. Check that the throttle lever is in the FAST position.	Engine speed is too slow to cut well.	Move throttle lever to the FAST position (p. 30).
2. Reduce forward speed.	Mower is moving too FAST for lawn conditions.	Shift to slow speed (p. 32).
3. Check cutting height adjustment levers.	Adjustment levers set at different positions.	Set all levers at the same cutting height position (p. 17).
4. Check grass bag.	Grass bag overfilled or clogged.	Empty the grass bag. Wash the grass bag if clogged with dirt (p. 61).
5. Check mower deck and blade.	Mower deck clogged.	Clean out the mower deck (p. 37).
	Wrong blade installed.	Install correct blade.
	Blade dull, worn, or damaged.	Sharpen or replace blade if necessary (p. 59 - 60).

STORAGE

This chapter explains how to protect your mower from rust and corrosion, and ensure that it will start easily when you want to use it again.

STORAGE PREPARATION	68
Cleaning	68
Engine	68
Mower Deck	68
Grass Bag	68
Fuel	69
Adding fuel stabilizer to extend fuel storage life	70
Draining the Fuel Tank and Carburetor	70
Engine Oil	71
Engine Cylinder	71
PLACING IN STORAGE	72
REMOVING FROM STORAGE	72

STORAGE

STORAGE PREPARATION

Proper storage preparation is essential for keeping your lawn mower trouble free and looking good. The following steps will help to keep rust and corrosion from impairing your mower's function and appearance, and will make the engine easier to start when you use the mower again.

Cleaning

1. Wash the mower, including the underside of the mower deck.

Engine

Wash the engine by hand, and be careful to prevent water from entering the air cleaner.

NOTICE

- Using a garden hose or pressure washing equipment can force water into the air cleaner. Water in the air cleaner will soak the filters and can enter the carburetor or engine cylinder, causing damage.
- Water contacting a hot engine can cause damage. If the engine has been running, allow it to cool for at least half an hour before washing.

Mower Deck

If using a garden hose or pressure washing equipment to clean the mower deck, be careful to avoid getting water into controls and cables, or anywhere near the engine air cleaner or muffler opening.

Before washing the underside of the mower deck, be sure the throttle lever is in the STOP position and the fuel valve is in the OFF position. Rest the mower on its right side, so the carburetor side is up. This will help to prevent fuel leakage and hard starting due to carburetor flooding. Wear heavy gloves to protect your hands from the blade.

Grass Bag

Remove the bag from the mower, and wash it with a garden hose or pressure washing equipment. Allow the bag to dry completely before storage.

2. After washing the mower wipe dry all accessible surfaces.

3. With the mower in an upright position, start the engine outdoors, and let it run until it reaches normal operating temperature to evaporate any water remaining on the engine.
4. While the engine is running, operate the blade control lever 4 or 5 times to expel water from the blade control mechanism. Allow the blade to spin for several minutes to ensure that no water remains.
5. Stop the engine, and allow it to cool.
6. After the mower is clean and dry, touch up any damaged paint, and coat other areas that may rust with a light film of oil. Lubricate all control cable cores with a silicone spray lubricant.

Fuel

Gasoline will oxidize and deteriorate in storage. Old gasoline will cause hard starting, and it leaves gum deposits that clog the fuel system. If the gasoline in your mower deteriorates during storage, you may need to have the carburetor and other fuel system components, serviced or replaced.

The length of time that gasoline can be left in your fuel tank and carburetor without causing functional problems will vary with such factors as gasoline blend, your storage temperatures, and whether the fuel tank is partially or completely filled. The air in a partially filled fuel tank promotes fuel deterioration. Very warm storage temperatures accelerate fuel deterioration. Fuel deterioration problems may occur within a few months, or even less if the gasoline was not fresh when you filled the fuel tank.

Fuel system damage or engine performance problems resulting from improper storage preparation are not covered under warranty.

You can extend fuel storage life by adding a gasoline stabilizer that is formulated for that purpose, or you can avoid fuel deterioration problems by draining the fuel tank and carburetor.

STORAGE

Adding Fuel Stabilizer to Extend Fuel Storage Life

When adding a fuel stabilizer, fill the fuel tank with fresh gasoline. If only partially filled, air in the tank will promote fuel deterioration during storage. If you keep a container of gasoline for refueling, be sure that it contains only fresh gasoline.

1. Add fuel stabilizer following the manufacturer's instructions.
2. After adding a fuel stabilizer, run the engine outdoors for 10 minutes to be sure that treated gasoline has replaced the untreated gasoline in the carburetor.
3. Stop the engine and move the fuel valve to the OFF position.

Draining the Fuel Tank and Carburetor

1. Move the fuel valve to the OFF position.
2. Remove the carburetor drain bolt with a 10 mm wrench, and drain the carburetor bowl fuel into an approved container.

⚠ WARNING

Gasoline is highly flammable and explosive.

You can be burned or seriously injured when handling fuel.

- Stop the engine and keep heat, sparks, and flame away.
- Refuel only outdoors.
- Wipe up spills immediately.

3. Move the fuel valve to the ON position. This will allow fuel in the fuel tank to drain through the carburetor bowl.

4. Reinstall the drain bolt.

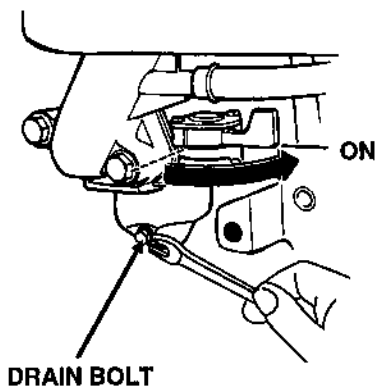

Engine Oil

Change the engine oil (see page 47).

Engine Cylinder

Remove the spark plug (see page 51). Pour a tablespoon (5 ~ 10 cc) of clean engine oil into the cylinder. Pull the starter rope several times to distribute the oil in the cylinder. Reinstall the spark plug.

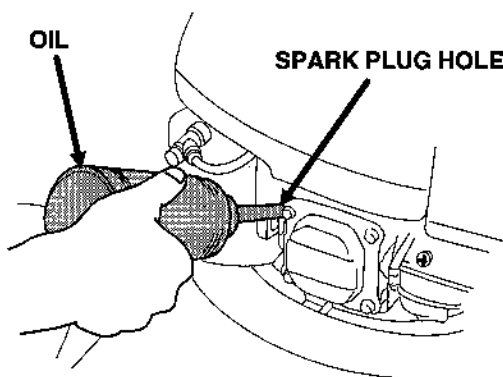

STORAGE

PLACING IN STORAGE

If your mower will be stored with gasoline in the fuel tank and carburetor, it is important to reduce the hazard of gasoline vapor ignition. Select a well-ventilated storage area away from any appliance that operates with a flame, such as a furnace, water heater, or clothes dryer. Also avoid any area with a spark-producing electric motor, or where power tools are operated.

If possible, avoid storage areas with high humidity, because that promotes rust and corrosion.

Unless all fuel has been drained from the fuel tank, leave the throttle lever in the STOP position and the fuel valve in the OFF position to reduce the possibility of fuel leakage.

Place the mower with its wheels on a level surface. Tilting can cause fuel or oil leakage.

With the engine and exhaust system cool, cover the mower to keep out dust. A hot engine and exhaust system can ignite or melt some materials. Do not use sheet plastic as a dust cover. A nonporous cover will trap moisture around the mower, promoting rust and corrosion.

REMOVING FROM STORAGE

Check your mower as described in the BEFORE OPERATION chapter of this manual.

If the fuel was drained during storage preparation, fill the tank with fresh gasoline. If you keep a container of gasoline for refueling, be sure that it contains only fresh gasoline. Gasoline oxidizes and deteriorates over time, causing hard starting.

If the cylinder was coated with oil during storage preparation, the engine will smoke briefly at startup. This is normal.

SPECIFICATIONS

This chapter gives dimensions, capacities, and other technical information.

MOWER MODELS	74
DIMENSIONS, WEIGHTS, AND CAPACITIES	74
ENGINE DESIGN AND PERFORMANCE	75
TRANSMISSION DESIGN AND PERFORMANCE	75
MAINTENANCE	76
TUNEUP	76

SPECIFICATIONS

MOWER MODELS

HRC216K1SXA : Manual starting; self-propelled; 2-speed transmission

HRC216K1HXA : Manual starting; self-propelled; hydrostatic transmission

DIMENSIONS, WEIGHTS AND CAPACITIES

	HRC216SXA	HRC216HXA
Maximum Length	65.6 in (1,665 mm)	
Overall Width	22.2 in (565 mm)	
Maximum Height (cutting height set at 3 in (76 mm))	44.5 in (1,120 mm)	
Minimum Height (cutting height set at 1 in (25 mm))	1005 mm (39.6 in)	
Dry weight (including grass bag)	123.5 lb (56.0 kg)	125.7 lb (57.0 kg)
Cutting Width	20.9 in (530 mm)	
Cutting Height (adjustable)	1 in (25 mm), 1 ³ / ₈ in (35 mm), 1 ³ / ₄ in (44 mm), 2 ¹ / ₈ in (54 mm), 2 ¹ / ₂ in (64 mm), 3 in (76 mm)	
Fuel Tank Capacity	0.53 US gal (2.0 ℓ)	
Engine Oil Capacity	0.69 US qt (0.65 ℓ)	
Transmission Fluid Capacity	4.4 fl oz (130 cc)	11.8 fl oz (350 cc)
Grass Bag Capacity	21.9 US gal (83 ℓ; 2.36 bushels)	

ENGINE DESIGN AND PERFORMANCE

Engine Model	GXV160K1
Engine Type	4-stroke, overhead-valve, single cylinder, forced air-cooled
Displacement	9.9 cu in (163 cc)
Bore and Stroke	2.7 x 1.8 in (68 x 45 mm)
Compression Ratio	8:1
Ignition System	Transistorized magneto
Maximum Horsepower	5.5 bhp (4.0 kW) at 3,600 rpm
Maximum Torque	7.96 ft-lb (10.8 N·m) at 2,500 rpm

TRANSMISSION DESIGN AND PERFORMANCE

Transmission Type	HXA: Hydrostatic SXA: 2-Speed
Maximum Mower Speed (with engine at 3,100 rpm)	HXA: SLOW: 1.6 ~ 2.2 mph (2.5 ~ 3.6 km/h) FAST: 3.4 ~ 4.0 mph (5.4 ~ 6.57 km/h) SXA: 1: 2.7 mph (4.3 km/h) 2: 3.7 mph (5.9 km/h)

SPECIFICATIONS

MAINTENANCE

Fuel	Unleaded gasoline with a pump octane rating of 86 or higher	See page 53.
Engine Oil	SAE 10W-30, API SH or SJ	See page 48.
Transmission Oil	HXA: Honda hydrostatic fluid SXA: Hypoid gear oil, SAE 90	See shop manual.
Spark Plug Type	Regular: NGK – BP5ES DENSO – W16EP-U CHAMPION – N12Y Resistor: NGK – BPR5ES DENSO – W16EPR-U CHAMPION – RN12Y	See page 50.
Maximum Governed Speed	3,100 ± 150 rpm	See shop manual.
Blade Control Cable	Adjust for $\frac{3}{4}$ – 1 in (20 ~ 25 mm) free play at blade control lever.	See page 54.
Drive Clutch Cable	HRC216SXA: Adjust for $\frac{3}{16}$ ~ $\frac{3}{8}$ in (5 ~ 10 mm) free play at drive clutch lever.	See page 55.
	HRC216HXA: Adjust for transmission arm alignment.	See page 56.
Throttle Cable	Adjust for proper choke operation and maximum governed speed.	See shop manual.
Blade Bolt Torque	36 ~ 43 ft-lb (49 ~ 59 N·m; 5.0 ~ 6.0 kg-m)	See page 60.

TUNEUP

Spark Plug Gap	0.028 ~ 0.031 in (0.7 ~ 0.8 mm)	See page 51.
Idle Speed (blade control disengaged)	1,700 ± 150 rpm	See page 52.
Valve Clearance (cold)	Intake: 0.15 ± 0.02 mm Exhaust: 0.20 ± 0.02 mm	See shop manual.
Other Specifications	No other adjustments needed.	

ADDITIONAL INFORMATION

This chapter contains additional information, Honda publications, and tells you how to contact us if you have a question or a warranty repair problem.

HONDA PUBLICATIONS	78
Shop Manual	78
Parts Catalog	78
WARRANTY SERVICE INFORMATION	79
OXYGENATED FUELS	80
SPARK ARRESTER SERVICE (optional equipment) ...	81

ADDITIONAL INFORMATION

HONDA PUBLICATIONS

These publications will give you additional information for maintaining and repairing your mower. You may order them from an authorized Honda servicing dealer.

Shop Manual

This manual covers complete maintenance and overhaul procedures. It is intended to be used by a skilled technician.

Parts Catalog

This manual provides complete, illustrated parts lists.

CUSTOMER SERVICE INFORMATION

Honda Power Equipment dealership personnel are trained professionals. They should be able to answer any question you may have. If you encounter a problem that your dealer does not solve to your satisfaction, please discuss it with the dealership's management. The Service Manager or General Manager can help. Almost all problems are solved in this way.

If you are dissatisfied with the decision made by the dealership's management, contact the Honda Power Equipment Customer Relations Office. You can write:

American Honda Motor Co., Inc.
Power Equipment Division
Customer Relations Office
4900 Marconi Drive
Alpharetta, GA 30005-8847

Or telephone: (770) 497-6400 M-F, 8:30 a.m. - 5:00 p.m. EST

When you write or call, please give us this information:

- Model and serial numbers (page 13)
- Name of the dealer who sold the lawn mower to you
- Name and address of the dealer who services your lawn mower
- Date of purchase
- Your name, address, and telephone number
- A detailed description of the problem

ADDITIONAL INFORMATION

OXYGENATED FUELS

Some conventional gasolines are being blended with alcohol or an ether compound. These gasolines are collectively referred to as oxygenated fuels. Some areas of the United States and Canada use oxygenated fuels to help reduce emissions.

If you use an oxygenated fuel, be sure it is unleaded and meets the minimum octane rating requirement.

Before using an oxygenated fuel, try to confirm the fuel's contents. Some states/provinces require this information to be posted on the pump.

The following are the EPA approved percentages of oxygenates:

ETHANOL ——(ethyl or grain alcohol) 10% by volume
You may use gasoline containing up to 10% ethanol by volume. Gasoline containing ethanol may be marketed under the name "Gasohol".

MTBE ——(Methyl Tertiary Butyl Ether) 15% by volume
You may use gasoline containing up to 15% MTBE by volume.

METHANOL ——(methyl or wood alcohol) 5% by volume
You may use gasoline containing up to 5% methanol by volume, as long as it also contains cosolvents and corrosion inhibitors to protect the fuel system. Gasoline containing more than 5% methanol by volume may cause starting and/or performance problems. It may also damage metal, rubber, and plastic parts of your fuel system.

If you notice any undesirable operating symptoms, try another service station, or switch to another brand of gasoline.

Fuel system damage or performance problems resulting from the use of an oxygenated fuel containing more than the percentages of oxygenates mentioned above are not covered under warranty.

SPARK ARRESTER SERVICE (optional equipment)

Your mower is not equipped with a spark arrester, and it may be illegal to operate the mower in some areas. Check local laws and regulations. An optional spark arrester is available from an authorized Honda servicing dealer.

The spark arrester must be serviced every 100 hours to keep it functioning as designed.

1. Remove the two nuts from the muffler shield, using a 10 mm socket wrench.
2. Remove the muffler heat shield, identification plate, muffler, and gasket.
3. Remove the spark arrester from the muffler.
4. Check for carbon deposits on the spark arrester and the exhaust port. Brush carbon deposits away. Be careful to avoid damaging the spark arrester screen.
5. Install the spark arrester in the muffler.
6. Install the muffler components on the engine, and tighten the two nuts securely.

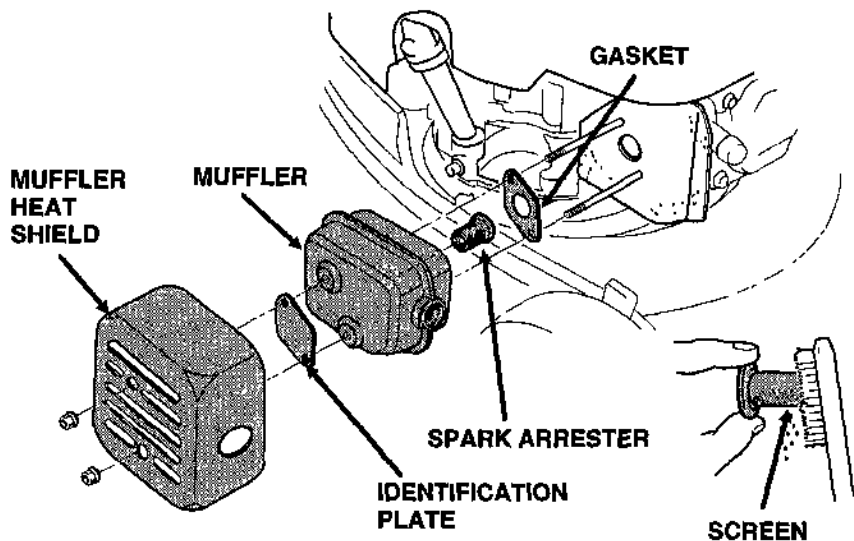

INDEX

A

- Air Cleaner Inspection 24
- Air Cleaner Service 49

B

- Blade:
 - Inspection 21
 - Installation 60
 - Removal 59
- Blade Control Lever:
 - Cable Adjustment 54
 - Operation 15 & 30

C

- Carburetor:
 - Adjustment 52
 - High Altitude Operation 52
- Choke 14 & 28
- Clogged Mower Deck 37
- Clothing Recommendations... 20
- Component Identification 12
- Contents 3
- Control Cable Adjustments:
 - Blade Control Lever 54
 - Drive Clutch Lever 55
 - Throttle Lever 58
- Cutting Height:
 - Adjustment Levers 17
 - Recommendations 36
- Cutting Width
 - Recommendations 36

D

- Description of Controls 14
- Drive Clutch Lever
 - Cable Adjustment 55
 - Operation 15 & 31

E

- Emission Control System
 - Information 44
- Engine:
 - Fuel Recommendations 53
 - Maintenance 47
 - Oil Change 47
 - Oil Level 22
 - Oil Recommendations 48
 - Refueling 23
 - Serial Number 13
 - Specifications 73
 - Starting 28
 - Stopping 33
 - Troubleshooting 63

F

- Fallen Leaves; Bagging 37
- Frame Serial Number 13
- Fuel:
 - Additive to Extend Storage
 - Life 70
 - Gasoline
 - Recommendations 53
 - Draining 70
 - Refueling 23
- Fuel Valve 14

INDEX

G

- Gasoline
- Recommendations53
- Grass Bag:
 - Cleaning 61 & 68
 - Inspection25
 - Removal and Installation.....25
 - Replacement61

H

- High Altitude Operation52

I

- Inspection Before Mowing:
 - Lawn20
 - Mower21
- Introduction..... 1

L

- Lawn:
 - Inspection Before Mowing..20
 - Mowing Tips36
 - Safe Mowing Practices.....34
- Leaves; Bagging37

M

- Maintenance:
 - Blade Removal and Installation59
 - Cable Adjustments54
 - Engine47
 - Grass Bag Cleaning & Replacement61
 - Importance42
 - Safety43
 - Schedule46
 - Specifications73
- Mower Deck Clogging.....37

Mowing:

- Around Obstacles, Gravel, Objects35
- Dry & Wet Grass37
- Fallen Leaves37
- Patterns38
- Slopes34
- Tips36
- When to Mow36

O

- Oil (for engine):
 - Change47
 - Level Check22
 - Recommendations.....48
- Operating the Controls for Mowing30

P

- Pre-Operation Check:
 - Lawn20
 - Mower21
- Publications.....78

S

Safety:	
Important Message to Employers	8
Important Message to Parents.....	7
Safe Mowing Practices	34
Important Safety Information	6
Safety Label Locations	9
Safety Message Definitions	2
Serial Numbers	13
Shift Lever Operation	16 & 32
Spark Arrester Service (optional equipment)	81
Spark Plug Recommendations & Service.....	50
Specifications:	
Capacities	74
Dimensions	74
Engine Design and Performance	75
Maintenance	76
Transmission Design and Performance	75
Tuneup	76
Weights	74
Starting the Engine	28
Stopping the Engine	33
Storage:	
Placing In Storage.....	72
Preparation	68
Removing From Storage....	72

T

Throttle Lever:	
Cable Adjustment	58
Operation	14 & 30
Transmission:	
Drive Clutch Cable Adjustment	55
Drive Clutch Lever Operation	15 & 31
Shift Lever Operation	16 & 32
Specifications	73
Transporting	39
Troubleshooting:	
Engine Problems	64
Mowing and Bagging Problems.....	65
Vibration Problems	65
Tuneup Specifications	76

W

Warranty Service	
Information.....	79
Washing:	
Grass Bag.....	61 & 68
Mower	68

QUICK REFERENCE INFORMATION

Fuel	Type	Unleaded gasoline with pump octane rating of 86 or higher (page 53).
	Capacity	0.53 US gallons (2.0 ℓ).
Engine Oil	Type	SAE 10W-30, API SH or SJ (page 48).
	Capacity	0.69 US quarts (0.65 ℓ).
Spark Plug	Type	Regular: NGK - BP5ES DENSO - W16EP-U, CHAMPION - N12Y Resistor: NGK - BPR5ES DENSO - W16EPR-U CHAMPION - RN12Y
	Gap	0.028 ~ 0.031 in (0.7 ~ 0.8 mm) (page 51).
Blade bolts	Torque	36~43 ft-lb (49 ~ 59 N·m; 5.0~6.0 kg-m) (page 60).
Carburetor	Idle speed	1,700 ±150 rpm, blade control disengaged (page 52).
Maintenance	Before each use	Check blade and bolt tightness (pages 21 & 60). Check grass bag (page 25 & 61). Check engine oil level (page 22). Check air cleaner (page 24).
	First 20 hours	Change engine oil (page 47). Check blade control mechanism (dealer service). Adjust blade control cable (page 54). Adjust drive clutch cable (page 55). Adjust throttle cable (dealer service).
	Subsequent	Refer to maintenance schedule on page 46.

HONDA

P/N 31VB5731
00X31-VB5-7310



Printed on
Recycled Paper

EM3

K
POM51764

IPC 15000.2003.C

PRINTED IN U.S./