

HONDA

Power

Equipment

OPERATOR'S MANUAL

MID-MOUNT ROTARY MOWER MODEL MM60

**FOR
HONDA H6522 COMPACT TRACTOR**

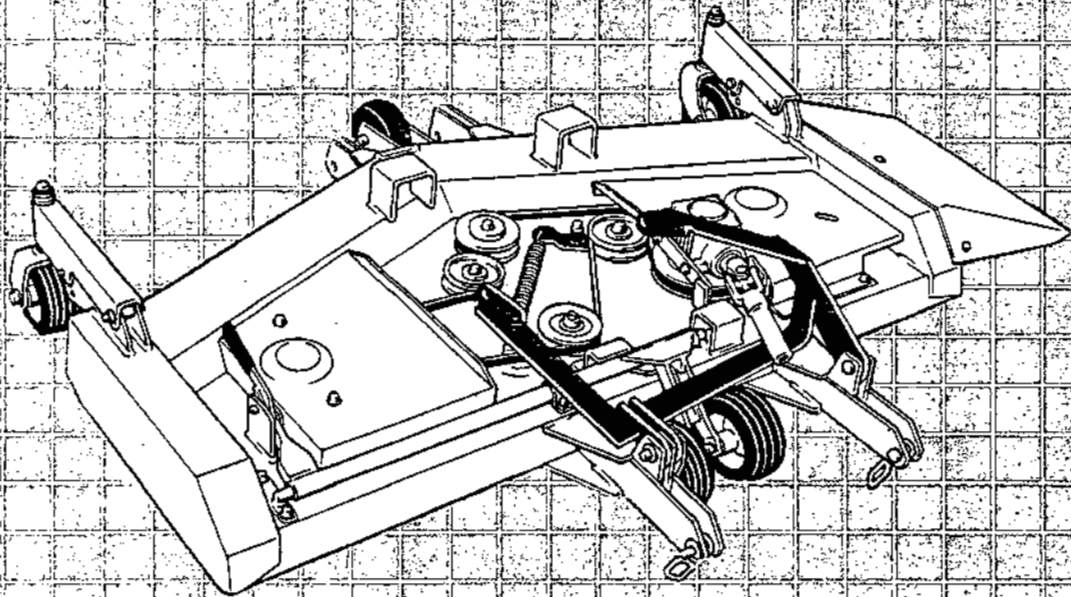

HONDA DEALER: PLEASE GIVE THIS PUBLICATION TO YOUR CUSTOMER

TO THE OWNER

Read this manual before operating your mower. The information presented will prepare you to do a better and safer job, Keep this manual handy for ready reference.

The mower you have purchased has been carefully engineered and manufactured to provide dependable and satisfactory use, Like all mechanical products, it will require cleaning and upkeep. Lubricate the mower as specified. Observe all safety information in this manual and safety decals on the mower and tractor.

For service, your authorized dealer has trained mechanics, genuine service parts, and the necessary tools and equipment to handle all your needs.

Use only genuine service parts. Substitute parts may not meet standards required for safe and satisfactory operation.

Model MM60 Rotary Mower

Record the serial number of your mower:

Serial Number (see Safety Decal page for location) _____

Provide this information to your dealer to obtain correct repair parts.

Throughout this manual, the term NOTICE is used to indicate that failure to observe this instruction can cause damage to equipment. The terms CAUTION, WARNING and DANGER are used in conjunction with the Safety-Alert Symbol, (a triangle with an exclamation mark), to indicate the degree of hazard for items of personal safety.

**The Safety-Alert Symbol means ATTENTION! BECOME ALERT!
YOUR SAFETY IS INVOLVED!**

 CAUTION Denotes a reminder of safety practices or directs attention to unsafe practices which could result in personal injury if proper precautions are not taken.

 WARNING Denotes a hazard exists which can result in injury or death if proper precautions are not taken.

 DANGER Denotes an extreme intrinsic hazard exists which would result in high probability of death or irreparable injury if proper precautions are not taken.

GENERAL INFORMATION

The purpose of this manual is to assist the operator in maintaining and operating this mower. Read it carefully. It furnishes information and instructions that will help you achieve years of dependable performance. These operating and maintenance instructions have been compiled from extensive field experience and engineering data. Some information may be general in nature due to unknown and varying conditions. However, you should be able to develop operating procedures suitable to your particular situation.

The illustrations and data used in this manual were current at the time of printing, but due to possible in-line production changes, your machine may vary slightly in detail. We reserve the right to redesign and change the machine as may be necessary without notification.

 WARNING Some illustrations in this manual show the mower with safety shields removed to provide a better view. The mower should never be operated with any safety shielding removed.

Throughout this manual, references are made to right and left directions. These are determined by standing behind the equipment and facing the direction of forward travel. Blade rotation is clockwise as viewed from the top of the mower.

INTRODUCTION	1
TO THE OWNER	1
GENERAL INFORMATION.....	2
SAFETY INFORMATION	4
SAFETY RULES.....	4
SET-UP AND ASSEMBLY	8
DEALER SET-UP INSTRUCTIONS.....	8
UNPACKING AND CHECKING PARTS	8
MOUNTING MOWER LIFT SYSTEM	11
ASSEMBLING MOWER	17
INSTALLING MOWER	18
INSTALLING MOWER TO TRACTOR	21
DETACHING MOWER FROM TRACTOR	25
OPERATION	28
ADJUSTING CUTTING HEIGHT	29
PRE-OPERATION CHECK LIST	30
OPERATING TECHNIQUE	31
CUTTING PATTERNS.....	32
OPERATING YOUR MOWER WITH OTHER EQUIPMENT	33
MAINTENANCE	36
OWNER SERVICE	36
LUBRICATION INFORMATION.....	37
BLADE INSPECTION	38
BLADE SERVICING	39
REPLACING BELTS	41
DEALER LEVEL MAINTENANCE.....	42
SPINDLE REPAIR	43
UNIVERSAL JOINT REPAIR	47
GEARBOX MAINTENANCE	49
STORAGE	52
TROUBLESHOOTING	53
SPECIFICATIONS	55
WARRANTY SERVICE	56

SAFETY INFORMATION

Safety is a primary concern in the design and manufacture of our products. Unfortunately, our efforts to provide safe equipment can be wiped out by a single careless act of an operator.

In addition to the design and configuration of equipment, hazard control and accident prevention are dependent upon the awareness, concern, prudence and proper training of personnel involved in the operation, transport, maintenance and storage of equipment. It has been said, "The best safety device is an informed, careful operator." We ask you to be that kind of an operator.

SAFETY RULES

**ATTENTION! BECOME ALERT!
YOUR SAFETY IS INVOLVED!**

The designed and tested safety of this equipment depends on it being operated within the limitations explained in this manual.

Training

- Safety instructions are important! Read this manual, the tractor manual and all safety rules.
- Know your controls and how to stop tractor engine and mower quickly in an emergency.
- Operators must be instructed in and be capable of the safe operation of the equipment, its attachments and all controls. Do not allow anyone to operate this equipment without proper instructions,
- Keep hands and body away from pressurized lines. Use paper or cardboard, not body parts to check for leaks. Hydraulic fluid (oil) under pressure will penetrate skin causing serious injury.
- Make sure that all operating and service personnel know that in the event hydraulic fluid penetrates skin, it must be surgically removed within a few hours by a doctor familiar with this form of injury, or gangrene may result.
- Do not allow children or unqualified persons to operate equipment.

Preparation

- Always wear relatively tight and belted clothing to avoid entanglement in moving parts. Wear sturdy, rough-soled work shoes and protective equipment for eyes, hands, hearing and head.
- Ensure that mower is properly mounted, adjusted and in good, operating Condition.
- Make sure mower driveline spring-activated locking collar slides freely and the balls are seated in mid-PTO shaft groove.
- Remove accumulated debris from mower to avoid fire hazard.
- Ensure all safety decals are installed and in good condition. (See Safety Decals section for location drawing.)
- Ensure shields and guards are properly installed and in good condition.
- A minimum 20% of tractor and equipment weight must be on tractor front wheels with mower in transport position. Without this weight, tractor could tip over causing personal injury or death. The weight may be attained with front wheel weights, ballast in tires or front tractor weights. When attaining the minimum 20% weight on the front wheels, you must not exceed the Roll Over Protection Structure (ROPS) weight certification. Weigh the tractor and equipment. Do not estimate.
- Inspect area to be cut and remove stones, branches or other hard objects that might be thrown, causing injury or damage.

Operational Safety

- You may not be able to stop the tractor safely if the clutch or brake pedal mechanisms are improperly adjusted, allowing them to contact mower components.
- When the mower lift stops are installed as instructed in this manual, properly adjusted clutch and brake pedal mechanisms will not contact mower components. You should frequently check that the tractor clutch and brake pedal mechanisms are in adjustment.
- If the clutch or brake pedal mechanisms can contact mower components, do not operate until properly adjusted.
- Do not operate mower unless discharge chute is installed.
- Keep bystanders away from equipment while it is in operation.
- Never direct discharge toward anyone. Operate only in daylight or good artificial light.
- Keep hands and feet away from mower while tractor engine is running.
- Stay clear of all moving parts.
- If your tractor is equipped with a ROPS, you must wear your seat belt.
- No riders are allowed on tractor or mower.
- Start engine from operator's seat after disengaging tractor PTO and placing transmission in neutral.
- Always sit in tractor seat when starting the engine or operating controls.
- Disengage power-take-off, shift tractor into neutral, and place all controls in neutral before starting tractor engine.
- Operate tractor mid-PTO at no more than 2400 RPM (maximum governed engine RPM).
- Make sure area behind you is clear before operating in reverse.
- Do not operate on steep slopes.
- Do not stop, start or change directions suddenly on slopes.
- Use extreme care and reduce ground speed on slopes and rough terrain.
- Watch for hidden hazards on the terrain during operation.

SAFETY INFORMATION

- Stop mower and tractor immediately upon striking an obstruction. Turn off engine, remove key, inspect and repair any damage before resuming operation.
- Before working underneath, raise mower, install transport lock and block mower securely. Hydraulic system leak down and failure of mechanical or hydraulic system can cause equipment to drop.
- Disengage power to mower, lower mower to ground, stop engine, set parking brake and remove key before dismounting tractor.
- Ensure all safety decals are installed and in good condition. (See Safety Decals section for location drawing.)
- Ensure shields and guards are properly installed and in good condition.

Storage

- Block mower securely for storage.

Maintenance Safety

- Always wear relatively tight and belted clothing to avoid entanglement in moving parts. Wear sturdy, rough-soled work shoes and protective equipment for eyes, hands, hearing and head.
- Lower mower to ground or block securely, turn tractor engine off, remove key and disconnect mower U-joint driveline from tractor PTO before performing any service or maintenance.
- Never perform service or maintenance with tractor engine running.
- Before working underneath, raise mower, install transport lock and block mower securely. Hydraulic system leak down and failure of mechanical or hydraulic system can cause equipment to drop.
- Keep all persons away from operator control area while performing adjustments, service or maintenance.
- Frequently check blades. They should be sharp, free of nicks and cracks and securely fastened.
- Use a new Nylok blade bolt when you replace the blade. Do not substitute any bolt for the special blade bolt. It is self-locking, meeting the non-loosening requirements for this application.
- Your dealer can supply genuine replacement blades. Substitute blades may not meet original equipment specifications and may be dangerous.
- Tighten all bolts, nuts and screws, and check that all cotter pins are installed securely to ensure mower is in a safe condition before operating.

Safety Decals

Replace immediately if damaged.

60

MODEL MM60

SER. MM2-

IMPORTANT

FILL GEAR BOX TO CENTER LINE OF HORIZONTAL SHAFT. USE SAE 90 GEAR LUBE. ALLOW TIME FOR OIL TO FLOW THRU BEARINGS. THEN RECHECK.

CUTTING HEIGHT ADJUSTMENT

POSITION	HEIGHT
1	1 1/2"
2	2"
3	2 1/4"
4	3"
5	4"

⚠ DANGER

KEEP AWAY!

SHIELD MISSING. DO NOT OPERATE.

⚠ DANGER

KEEP AWAY!

SHIELD MISSING. DO NOT OPERATE.

⚠ DANGER

KEEP AWAY!

THROWN OBJECTS OR BLADE CONTACT CAN CAUSE SERIOUS INJURY OR DEATH. KEEP DISCHARGE CHUTE AND SHIELDS IN PLACE.

⚠ DANGER

KEEP AWAY!

SHIELD MISSING. DO NOT OPERATE.

IMPORTANT

LUBRICATE EVERY 8 HOURS OF OPERATION

APPLY GREASE TO ALL SIDES OF DRIVELINE MALE HALF WHERE IT MEETS FEMALE HALF. EXTEND AND RETRACT DRIVELINE TO DISTRIBUTE GREASE

⚠ WARNING

TO AVOID SERIOUS INJURY OR DEATH!

- READ OPERATOR'S MANUALS & FOLLOW ALL SAFETY PRECAUTIONS. (CONTACT DEALER FOR MANUALS)
- KEEP SHIELDS AND GUARDS IN PLACE. KEEP CLEAR OF DRIVES AND BELTS.
- LOWER IMPLEMENT, STOP ENGINE AND REMOVE KEY BEFORE DISMOUNTING.
- CLEAR MOWING AREA OF DEBRIS.
- DO NOT OPERATE MOWER IN VICINITY OF OTHER PERSONS. NO RIDERS
- KNOW HOW TO STOP TRACTOR AND EQUIPMENT QUICKLY IN AN EMERGENCY.
- BLOCK UP IMPLEMENT AND REMOVE KEY BEFORE WORKING UNDERNEATH. ALLOW NO CHILDREN OR UNQUALIFIED PERSONS TO RUN EQUIPMENT.
- BE CAREFUL ON UNEVEN TERRAIN. DECREASE SPEED WHEN TURNING.
- DO NOT OPERATE IN TRANSPORT POSITION.

⚠ WARNING

- PTO SPEED MUST NOT EXCEED 2400 RPM.
- LOCK DRIVELINE ON TRACTOR PTO.
- A LOOSE DRIVELINE OR A HIGHER PTO RPM CAN CAUSE PERSONAL INJURY AND EQUIPMENT FAILURE.

SET-UP AND ASSEMBLY

DEALER SET-UP INSTRUCTIONS

Assembly of this mower is the responsibility of the dealer. The mower should be delivered to the owner completely assembled, lubricated and adjusted for normal mowing conditions.

Using these instructions, set mower up as received from the factory. Complete Check Lists on Page 10 when set-up is complete.

You may install the MM60 mower with the FL6555 sub frame installed. The front loader must be removed from the sub frame. If you also have a BH6575 Back Hoe, both the back hoe and its sub frame must be removed. The adjustment of the lift rod is different from the standard installation. These differences are explained in the appropriate sections. Follow these procedures to avoid damage to deck and linkage.

The mower is shipped partially assembled. Assembly will be easier if components are aligned and loosely assembled before tightening hardware. Recommended torque values for hardware, are included in the assembly instructions.

Select a suitable working area. Open parts boxes and lay out parts and hardware to make location easy. Refer to illustrations, accompanying text, parts lists and exploded view drawings.

For all pins, shafts and other bearing surfaces, lubricate bearing area with a lithium based grease of #2 consistency with a MOLY (molybdenum disulfide) additive before installing. The manual will also indicate when grease is necessary.

⚠ CAUTION Always wear relatively tight and belted clothing to avoid entanglement in moving parts. Wear sturdy, rough-soled work shoes and protective equipment for eyes, hands, hearing and head.

⚠ WARNING

- Before working underneath, raise mower, install transport lock and block mower securely. Hydraulic system leak down and failure of mechanical or hydraulic system can cause equipment to drop.
- Keep all persons away from operator control area while performing adjustments, service or maintenance.

UNPACKING AND CHECKING PARTS

The mower assembly kit contains the following parts:

- Mower deck with rear linkage installed
- Lift plate assembly
- Box containing lift linkage and hardware

Unbolt the mower deck, and the lift plate assembly and cut the packing straps holding down the rear linkage and mower drive shaft. Packing list is contained in both the crate holding the mower, and in the parts box in the crate. Before assembling check for missing or damaged parts.

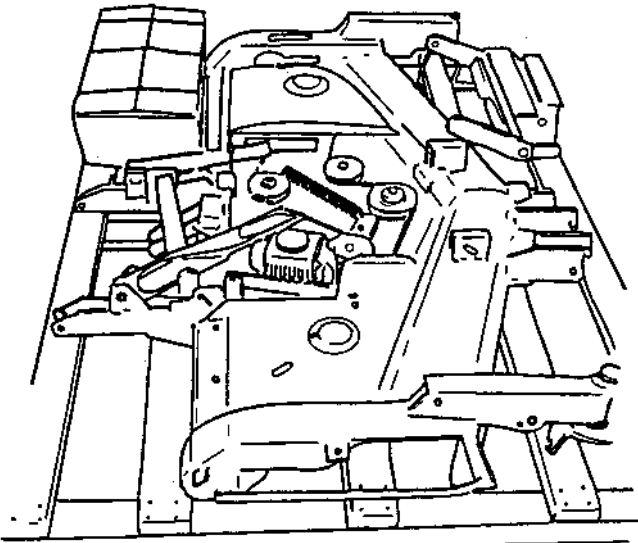

Mower Assembly Kit in Crate

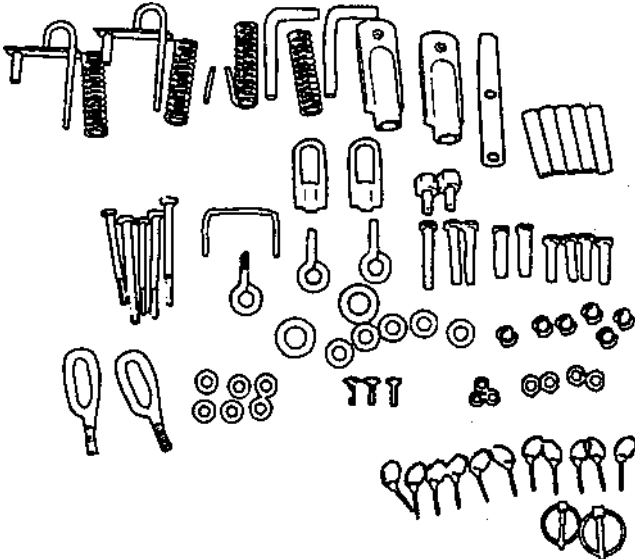

Parts in Burlap Bag

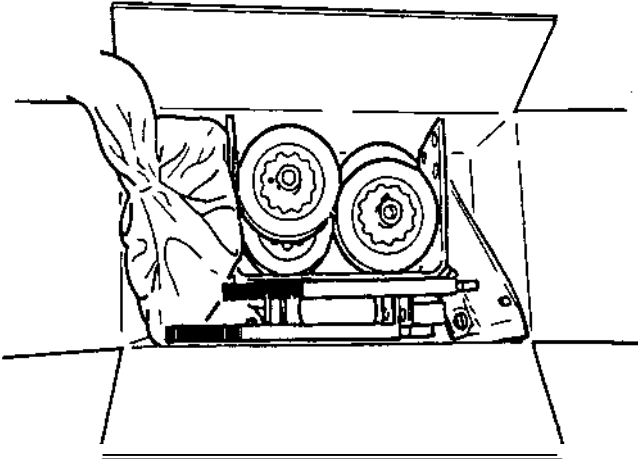

Parts Box

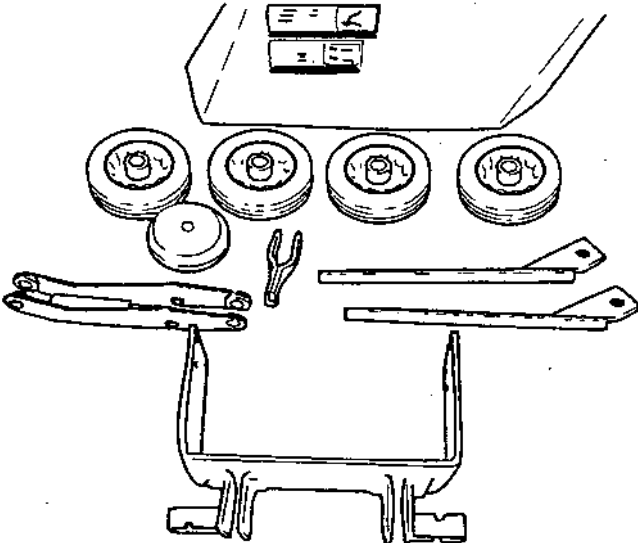

Parts in Parts Box

SET-UP AND ASSEMBLY

Pre-Delivery Check List (Dealer Responsibility)

1. Inspect the mower thoroughly after assembly to ensure it is set up properly before delivering it to the customer. The following check lists are a reminder of points to inspect. Check off each item as it is found satisfactory or after proper adjustment is made.
2. Check all bolts to be sure they are correctly torqued.
3. Check that all linchpins are properly installed.
4. Lubricate all grease fittings; check to make sure a small amount of grease comes out of seal.
5. Check that gearbox is serviced and that vent plug is properly installed and seals are not leaking.
6. Check that blades have been properly installed.

Delivery Check List (Dealer Responsibility)

1. Check mower attitude and belt alignment.
2. Check that mower lift is properly adjusted. (See Assembly instructions.)
3. Show customer how to make adjustments.
4. Explain importance of lubrication to customer and point out lubrication points on mower.
5. Point out safety features, shielding and options.
6. Present the Operator's Manual, and ask customer to become familiar with all sections.
7. Explain to customer that when mower is transported on a road or highway, safety devices should be used for adequate warning to operators of other vehicles.

MOUNTING MOWER LIFT SYSTEM

Install with the tractor on level ground. Lock the parking brake, set the transmission lever in "N" (Neutral) and the PTO clutch lever in the "OFF" position. Set Lift Control lever to "DOWN" and turn Lowering Speed Control knob fully counter-clockwise ("FAST"). This allows you to pull the rear lift arms down by hand and makes assembly easier.

Installing Mower Lift Plate to Tractor

1. Remove drawbar assembly; this is bolted onto the transmission housing below the Rear PTO. Retain bolts, nuts and spacers for installation of lift plate assembly. Remove any dirt and debris from bottom of transmission housing and make sure bolt holes and screw threads are clean.
2. Assemble Y-lift bracket to lift plate assembly. Raised flange on lift plate assembly will face rear of tractor. Insert Y-lift bracket so that fork of Y faces front of tractor.
3. Attach mower lift plate assembly to tractor, passing the two projecting stud bolts on the transmission housing through the holes in the lift plate flange. Slide on 2 spacers previously removed and hand tighten both 26 mm flange locknuts.
4. Reach beneath the mower lift plate assembly and carefully insert the four 12 mm x 32 mm bolts through holes in lift plate assembly and into threaded holes on bottom of transmission housing. Housing is made of aluminum, so start bolts by hand to guard against cross threading. Tighten to 7 kg-m (50 ft-lb).
5. Finish by tightening two 26 mm flange locknuts on projecting studs to 7 kg-m (50 ft-lb).

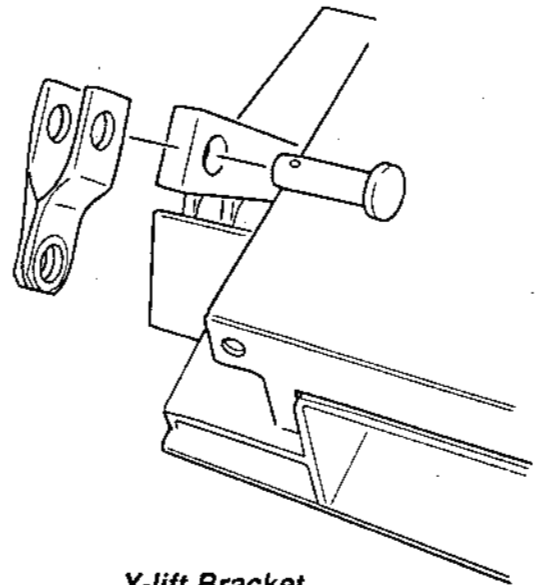

Y-lift Bracket

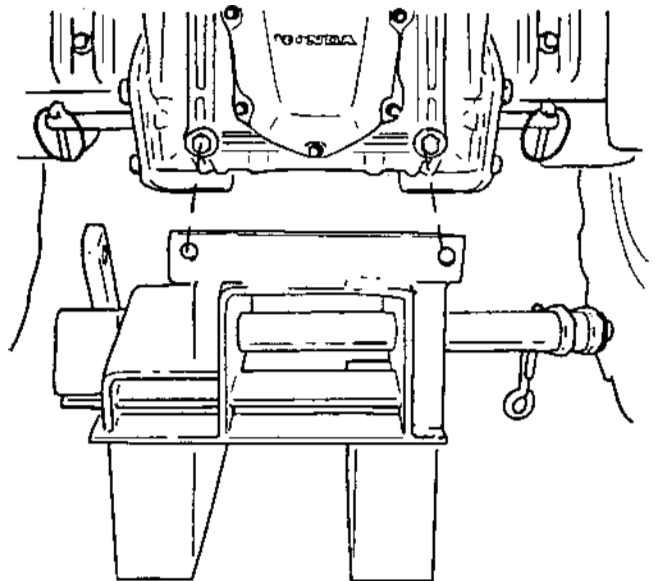

Mower Lift Plate

CAUTION Wear heavy gloves to protect your hands when installing lift link kit and mower deck.

CAUTION Lifting system can crush fingers and hands, so keep them clear of links and lift arms when operating.

SET-UP AND ASSEMBLY

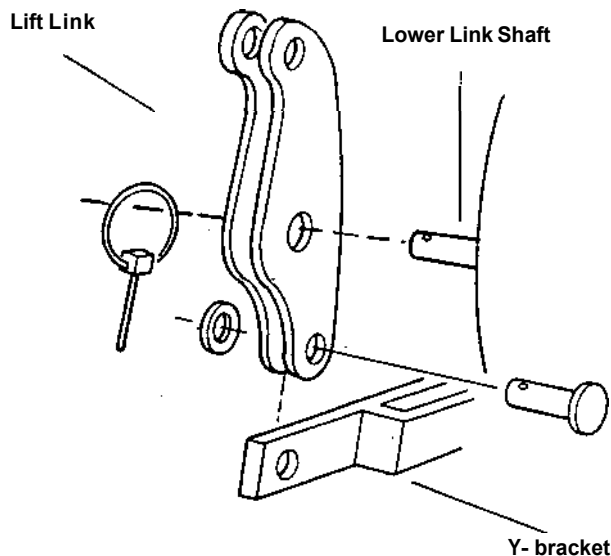

Attaching Lift Link to Lift Plate Assembly (For Tractors Without Rear Three Point Hitch)

1. Slide middle hole in lift link onto greased left hand lower link shaft which comes installed on the tractor. Install lift link so that it is vertical and the end with two holes is down. Lift link should face rearward as illustrated. Be sure to apply grease to shaft. Secure with linchpin.
2. Use a block of wood to raise left arm of lift plate assembly about 150 mm (6 in) to make attaching the Y-bracket and the bottom hole of the lift link easier. Line up hole in Y-bracket with lower hole in lift link moving arm and lift link until they align. Insert greased 22 mm x 76 mm clevis pin and secure with cotter pin, passing pin from top to bottom. Head on clevis pin faces in.

Attaching Lift Link to Lift Plate Assembly (For Tractors With Rear Three Point Hitch)

1. Remove left hand three point hitch lower link from lower link shaft.
2. Mount lift link and lower link back on lower link shaft by lining up middle hole in lift link and hole in lower link. Pass greased lower link shaft through both as illustrated. Secure with linchpin, passing pin from top to bottom.
3. Support lift plate assembly arms on block of wood as described above. Move lift link and Y-bracket on lower lift plate assembly until hole in Y-bracket and bottom hole in lift link line up. Insert greased 22 mm x 57 mm clevis pin with head facing in and secure with cotter pin, passing pin from top to bottom.

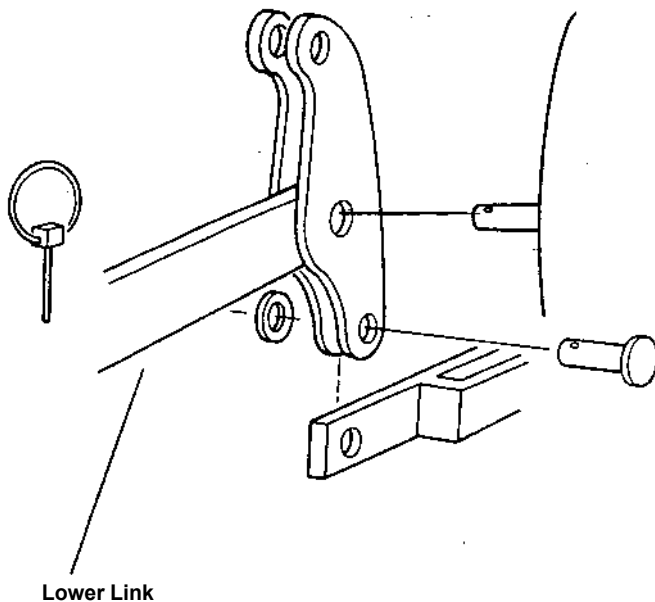

Installing Lift Rods (For Tractors Without Rear Three Point Hitch)

1. Adjust the lift rod to 365 mm (14.4 in) measured from eye to eye as illustrated. Adjustment is made by turning barrel of rod, then secured by tightening nut. Be sure that an equal length of threads shows on either end of barrel.

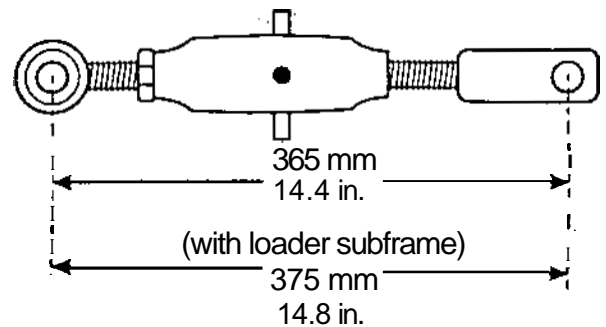

2. Slide eye of lift rod over pin on tractor lift arm. Position clevis of lift rod between brackets on lift link. Note that outside leg of lift rod goes outside of lift link as illustrated. Install with greased 22 x 76 mm clevis pin with head on left side as shown. Secure both ends with 22 mm washers and linchpins.

NOTE: The eye of the lift rod is not straight. The curve should point to the inside of the tractor when properly installed.

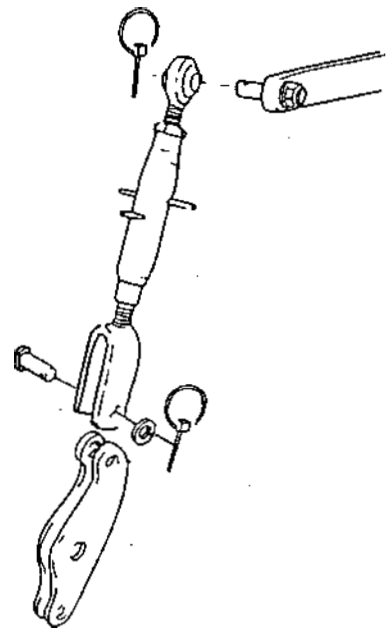

SET-UP AND ASSEMBLY

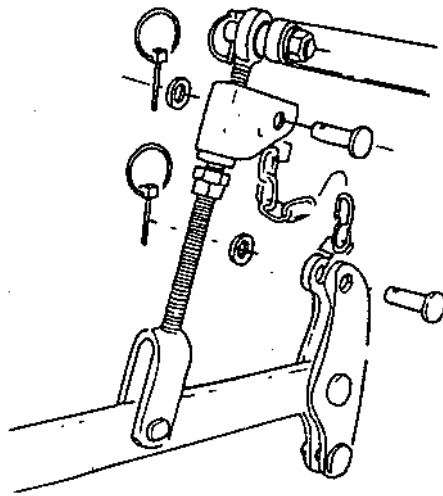
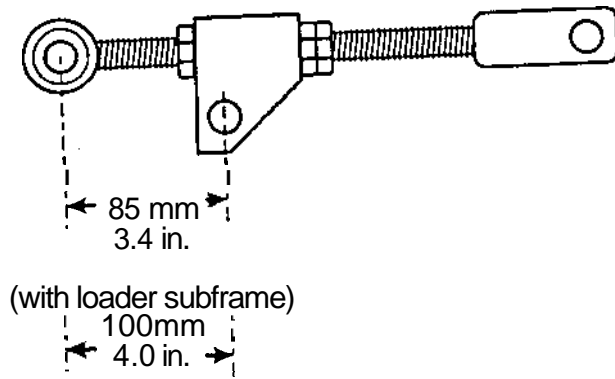

Installing Lift Rods on Lower Link Lift (For Tractors With a Rear Three Point Hitch)

1. Replace the existing left hitch rod with the unit provided with the mower.
2. Loosen the locknut and the adjusting nuts and turn them to position the bracket hole 85 mm (3.4 in) from the lift rod eye (center-to-center measurement). The bracket must face forward.
3. Tighten the adjusting nuts and secure with the locknut.
4. Couple lift link chain and lift link with greased 16 mm lift pin. Head of pin faces inward. Secure with washer and cotter pin. Attach upper end of lift link chain to bracket on lift rod, with greased 16 mm lift pin. Head of pin faces inward. Secure with washer and linchpin.

Adjusting Lift Rod (For Tractors With and Without Rear Three Point Hitch)

Follow this procedure if you do not have a loader subframe installed.

Adjust the lift rod clearance by starting the engine, and shifting the Lift Control lever to "UP". Make sure hands are clear of lift arms before starting. Engine will not start unless operator is seated. Raise until lift arm reaches top or until resistance is encountered. If resistance is encountered, stop. Turn Lowering Speed control fully clockwise to lock arms up. Turn engine off. Grasp lift rods and check them for slack. They should be able to slide slightly on their pins. If there is no-slack in the lift rods, increase clearance as illustrated.

NOTICE Lifting system can be seriously damaged if arm presses against stop.

Adjusting Lift Rod (Tractors With Rear Three Point Hitch)

To increase clearance turn bottom nut on adjuster counterclockwise to loosen, slide down flange and then snug top nut. To decrease clearance, slide adjuster up as shown.

Adjusting Lift Rod (Tractors Without Rear Three Point Hitch)

Turn the barrel of the lift rod by the projecting pins to shorten or lengthen the rod. Move adjuster as required. The projecting pins must point side to side (transversely) when you are finished. If they don't, turn the barrel in the direction to increase clearance until they do.

Restart engine, move Lift Selector lever to "UP". When lift arms reach top position, stop engine, apply brakes and re-check clearance. Keep hands and fingers clear of lift system when operating to avoid injury. There should be slack in the linkage. If there is not, readjust as necessary. Tighten lock-nuts after adjusting both types of lift rods.

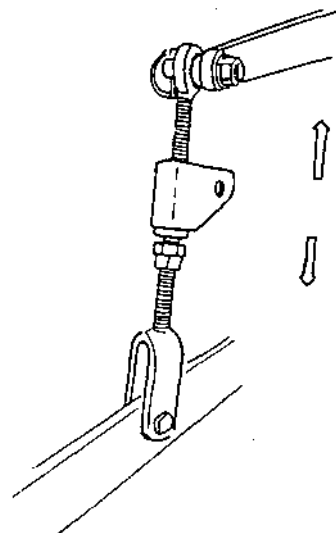
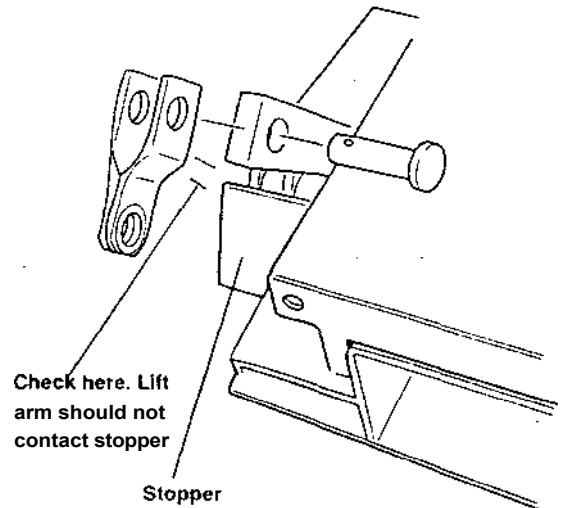

With Three Point Hitch

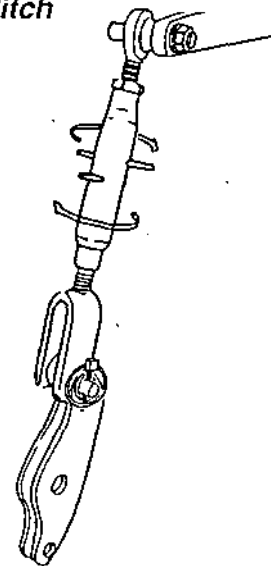

Without Three Point Hitch

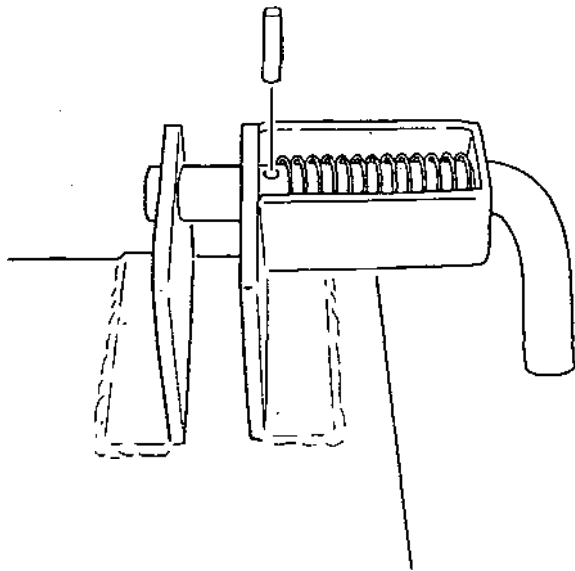

Front Link Bracket

Subassembling Front Link Brackets

Assemble by compressing the front spring and inserting it in the front bracket slot. Pass greased front quick release pin through hole in the front bracket and spring. Pull back spring slightly to uncover hole in quick release pin. Use hammer to tap in spring pin until it is equidistant from both sides of quick release pin.

NOTE: Hold back bottom of spring so that pin clears it.

Assemble both right and left brackets.

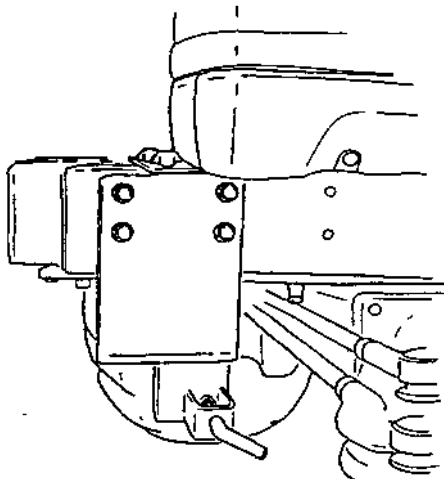

Front Link Bracket

Mounting Front Link Bracket to Tractor

1. From bottom, slip the assembled front mounting bracket up onto the front frame rails.
2. Insert 8 flange bolts 12 mm x 30 mm. Tighten all to 6 kg-m (43 ft-lb).

NOTE: With pins correctly installed, they will face rearward and downward when front link bracket is installed on the tractor.

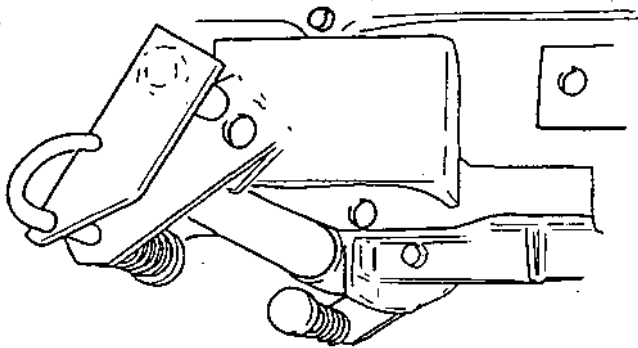

Rear Link Bracket

Assembling Rear Link Bracket

Insert the greased rear quick release pin in the mounting bracket attached to the tractor frame. It is located beneath the tractor along the mid-line as illustrated. Pass the long arm of the quick release pin through the lower hole in the bracket and the spring. Compress the spring and slide washer over hole in arm. Secure with split pin, spreading legs of split pin. Assemble both right and left brackets.

ASSEMBLING MOWER

Checking Rear Mower Deck Links

Rear mower links will come installed. Check that vibration in shipping has not shaken loose the two clevis pins in brackets at rear of mower. They are secured with linchpins.

Rear deck links should face forward, towards front of mower, before driving tractor over mower. They cannot be rotated forward after tractor is above mower deck.

Mower driveline and U-joint should be on top of stabilizer bar, not caught below it.

Be sure the left rear deck link is installed with the side marked "UP" facing top.

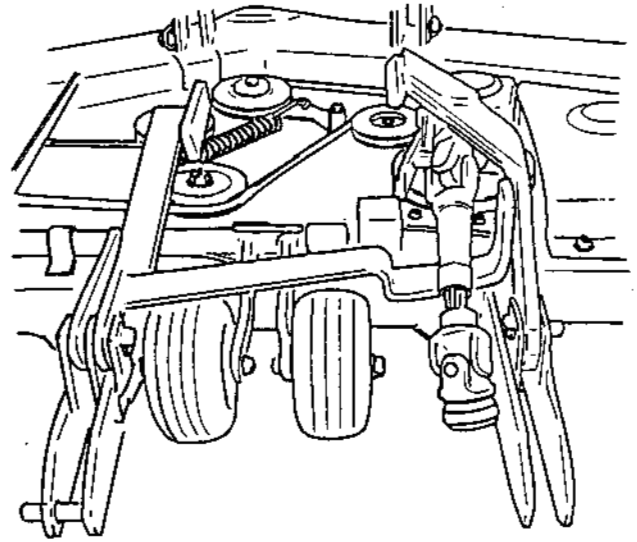

Rear Mower Deck Links

Installing Deck Hooks

Right and left mower deck hooks are installed on brackets in the front center of the deck. See position as indicated. Screw mower deck hook into adjustable pin. Insert pin into slot in bracket. Secure with washer and linchpin.

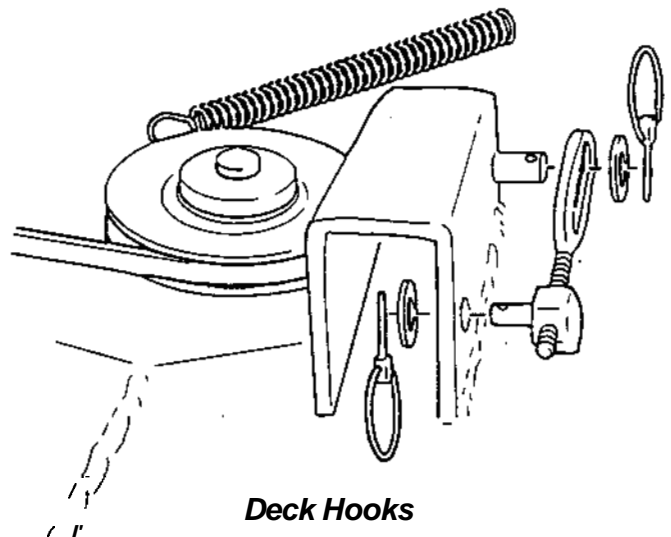

Deck Hooks

INSTALLING MOWER

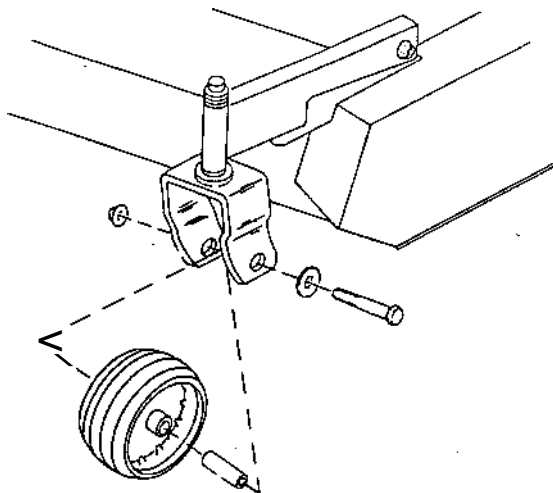

Front Caster Wheel

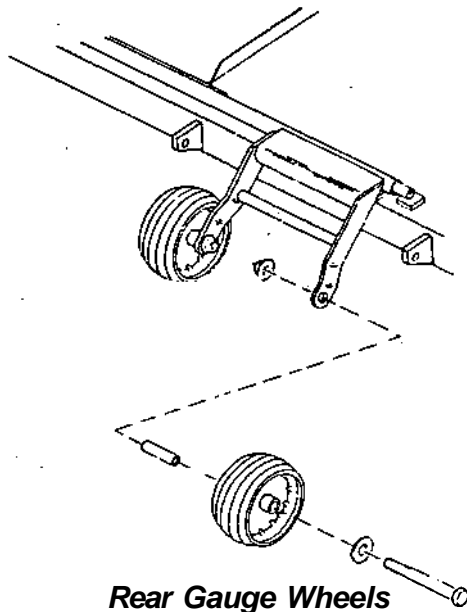

Rear Gauge Wheels

Installing and Adjusting Wheels

1. Pull release pin on wheel yoke so that wheel arm can be raised to insert wheel. Assemble wheel by inserting 1/2 x 5 in. sleeve through wheel. Place 1/2 in. washer on 1/2 x 5 in. bolt and insert through yoke and sleeve in wheel. Secure with flanged locknut. Tighten locknut so that sides of bracket touch wheel sleeve without binding. Do not over-tighten. Repeat for other front caster wheel.
2. Assemble the rear gauge wheels so that grease fittings are to the inside for lubrication access. Raise rear of mower deck with lever or jack and insert wood block beneath mower deck to support it while installing wheels. Insert sleeve through wheel. Place washer on bolt and insert through sleeve in wheel and rear gauge wheel arm. Secure with flanged locknut. Tighten locknut so that sides of bracket touch wheel sleeve without binding. Do not over-tighten. Repeat for opposite side.
3. Raise front and rear wheels to middle position, insert pin in center hole of adjustment bracket. Cutting height will be 2.75 in. Level the mower to assure proper cut. Mower also needs slight forward tilt. If adjusting wheels and blade height after installing mower on tractor, make sure engine is off and key is removed before looking under mower.

⚠ WARNING Support mower deck solidly while installing wheels. Keep fingers and feet clear of deck until deck is firmly supported.

Leveling the Mower

Level the mower to assure proper cut. Mower needs slight (3/8 in) forward tilt. If you are adjusting wheels and blade height after installing mower on tractor, make sure engine is off and key removed before looking under mower.

NOTE: Before measuring blade height, turn mower blades so that the right and left blades point towards front of mower.

NOTE: Tool is available (see illustration) for ease of measurement.

1. To level mower from side to side, measure distance from front blade tip to ground. For left and right blades, measurements should be within 5 mm (1/4 in) of each other. Move washers as necessary to raise the low corner. To add washers, raise mower deck until wheels clear ground by about 5 in.
2. Place wood block or floor jack under edge of mower to hold it while wheel is removed. Drive out split pin from lower caster wheel to remove caster wheel shaft. Move washers to the bottom part of caster wheel shaft as illustrated. Each washer changes height by 3 mm (about 1/8 in).
3. Re-attach wheel, let mower down to rest on wheels, and re-measure. Repeat the adjustment until the difference between blade heights is approximately 5 mm (1/4 in). Do not replace split pin until after adjusting forward tilt.
4. Adjust forward tilt by measuring from front and rear of blades to ground. The front of the blades should be about 10 mm (3/8 in) lower than the rear of the blades. If difference is less than 5 mm (1/4 in) take washers from bottom of gauge wheel shaft and move to top. If difference in blade tip to ground measurements is more than 15 mm (1/2 in), take washers from top of gauge wheel shaft and move to bottom as illustrated. Move equal numbers of washers for both left and right sides. Replace split pins.

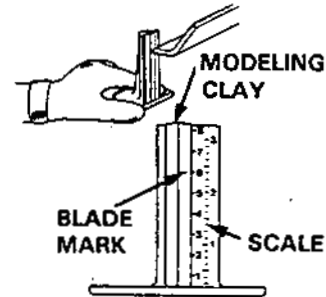

Mower Leveling Tool
HONDA Part No.
07JPJ-750010A

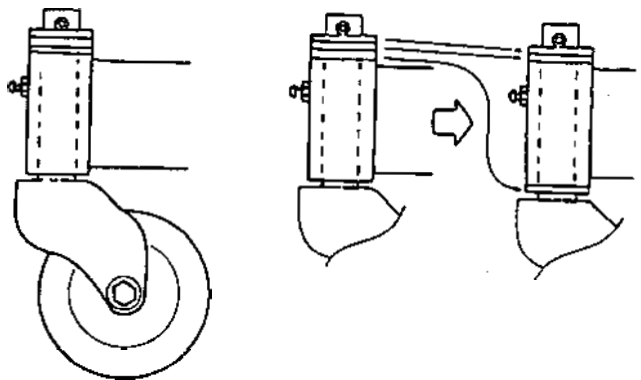

Caster Wheels

Installing Front Anti-Scalping Roller

1. Insert 1/2 x 5 in sleeve in wheel. Place 1/2 x 5 in. bolt through brackets for front anti-scalping roller and through sleeve as illustrated.
2. Secure with 1/2 in flanged hex locknut. Tighten locknut so that sides of bracket touch wheel sleeve without binding.

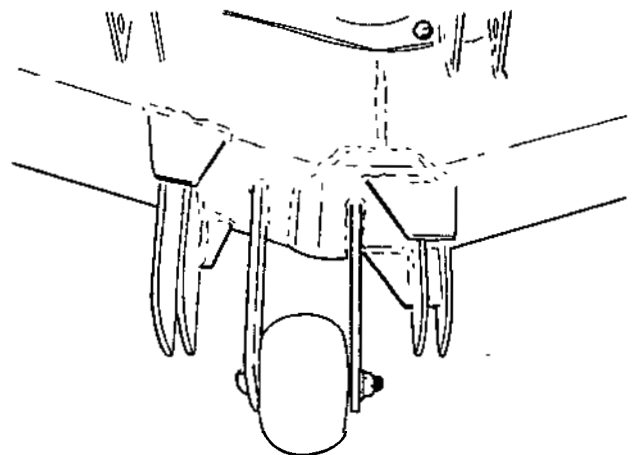

Front Anti-Scalping Roller

INSTALLING MOWER

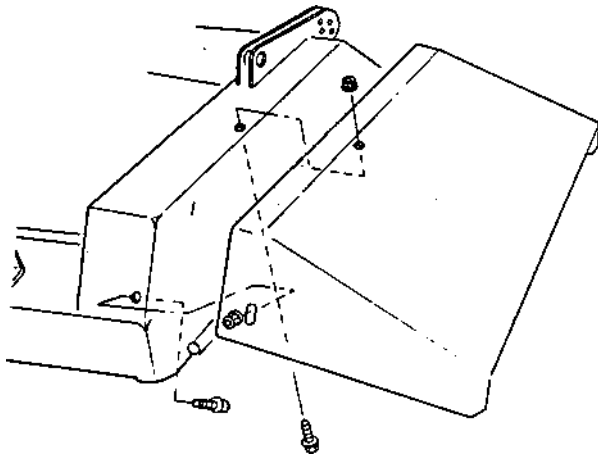

Discharge Chute

Installing Discharge Chute Cover

1. Using 3/8 x 1 in. carriage bolts, insert bolts from under mower deck, passing through holes in deck and discharge chute.
2. Secure with 3/8 in. flange locknuts.

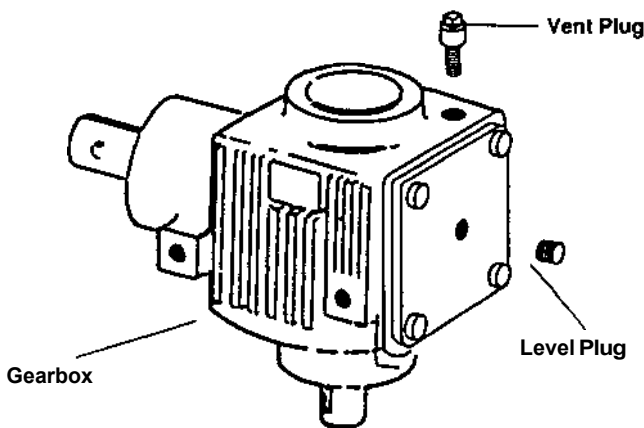

Gear Box

Installing Gear Box Oil and Vent Plug

Gearbox is shipped WITHOUT oil. Plastic gearbox vent plug comes in burlap bag with other mower assembly parts.

NOTICE Before operating mower, check gearbox and fill if necessary with SAE 90W gear lube. Operating without oil will severely damage gearbox.

1. Remove level plug.
2. Add oil until it seeps out level plug hole.
3. Allow several minutes for oil to flow through bearings and refill as necessary.
4. Install both plugs

Attaching Front Mower Links To Mower

1. Screw the adjustable plate link onto the right and left front mower links. Adjust the plate link as shown in illustration, so that the straight line length is 450 mm (17.75 in). Face the plate link to the outside as shown and insert into the projecting brackets on the mower deck .
2. Install both right and left links. Secure with 16 mm greased clevis pin inserting pin from outside. Insert linchpin to lock.

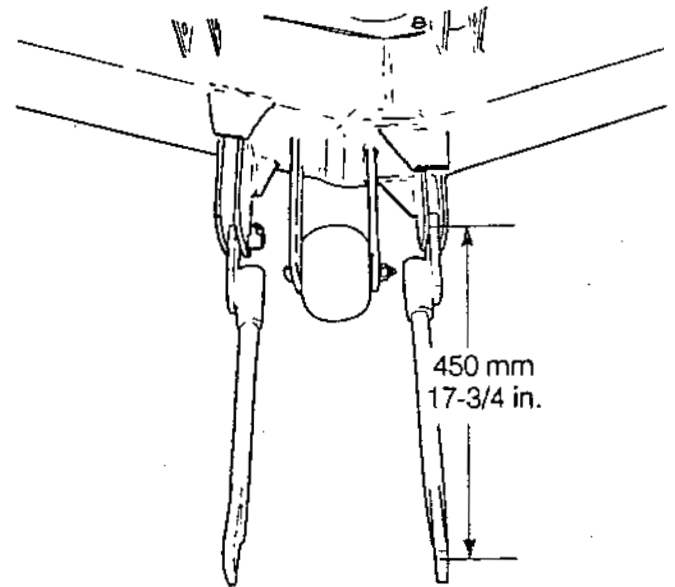

Front Mower Links

INSTALLING MOWER TO TRACTOR

1. Adjust gauge wheels to lowest cutting position.
2. Chock right and left front wheels as shown.
3. Start the tractor and keep engine at low idling speed. Set the lift control lever to the "UP" position and keep the lift arm up.

NOTICE Drive front wheels over the flat area of the pulley covers only! Avoid running over gear box, drive shaft and rear links to prevent damaging them.

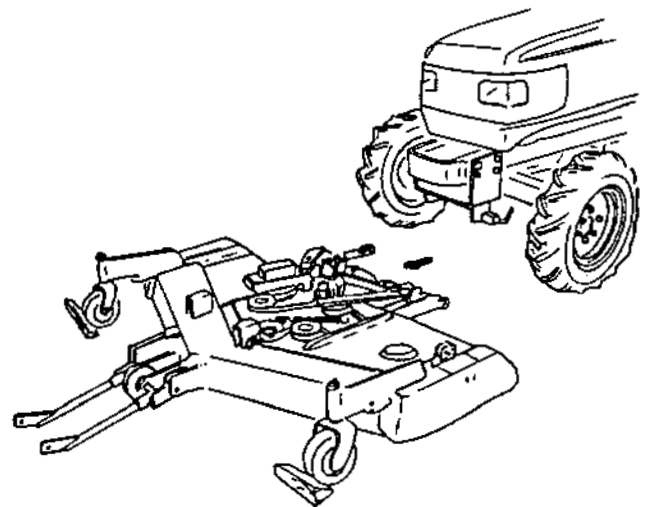

Front Wheels Chocked

INSTALLING MOWER

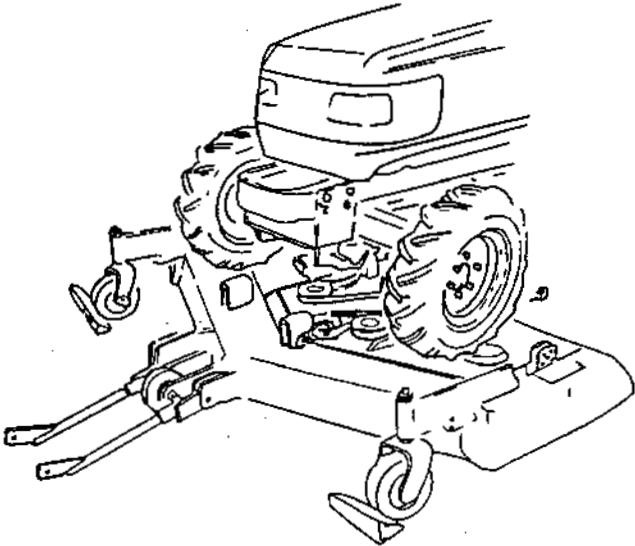

4. Put the transmission range selector in "1." For A-4 models, engage 4-wheel drive. Press the clutch, put the main transmission selector in "1", and slowly drive over the mower, controlling your speed with the clutch and brake.
5. Shut engine off after driving front wheels over mower and remove key from ignition.

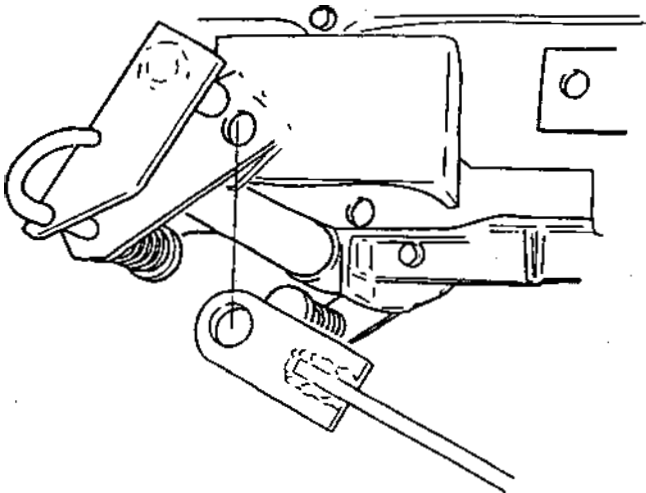

Rear Mower Links Attach to Mower

Attaching Rear Mower Links to Tractor Frame

1. Adjust the gauge wheels to their middle cutting position (2 in).
2. Roll the deck forward or backward, right or left to position the rear links under the quick-release pins.
3. Attach the left rear mower link first. Pull back on quick release pin, then lift mower link by hand to the frame brackets. If holes in rear link do not line up with frame bracket, adjust the position of the mower until they do. Keeping the holes lined up, pull the quick release pin towards you and turn it to fit it into the holes. Release to lock. Make sure that the pin reaches through the holes inside the frame bracket. Shake the rear mower link to check for free movement.
4. Attach the right rear mower link in the same manner.

Attaching Front Mower Links to Front Bracket

1. Pull back on quick release pin in right or left front link bracket and twist until the spring pin catches in slot. Raise front mower link to bracket and line up holes. Looking from inside the bracket, check alignment of holes.
2. If the holes in the bracket and the front link do not line up, twist front deck link by screwing it in or out to adjust length. If link is too long, turn clockwise to shorten. If link is too short, turn counterclockwise to lengthen. Adjust both links an equal number of turns.
3. When the holes line up, pull quick release pin towards you and turn to release spring pin from slot. Make sure that quick release pin is fully inserted through the holes inside the frame bracket.

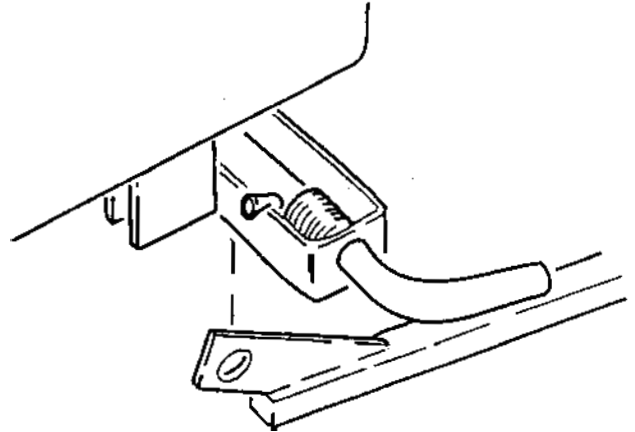

Front Mower Links Attach to Front Bracket

Attaching Driveline to Mid-PTO

1. Engine should be OFF with key removed before attaching U-joint to Mid-PTO.

NOTE: The mower drive shaft is a 2-piece assembly. The inner shaft can be removed from the outer shaft. They fit together in only one way. A red paint dot on each section marks the blind spines which must be aligned.

2. Set the PTO Selector to the REAR position before attaching (this allows the Mid-PTO to turn freely).
3. Line up U-joint with shaft of the Mid-PTO. Splines will engage when correctly lined up. Pull back spring loaded locking collar on U-joint (towards the mower deck) as illustrated to insert U-joint into Mid-PTO. Slip U-joint into shaft until a click is heard.

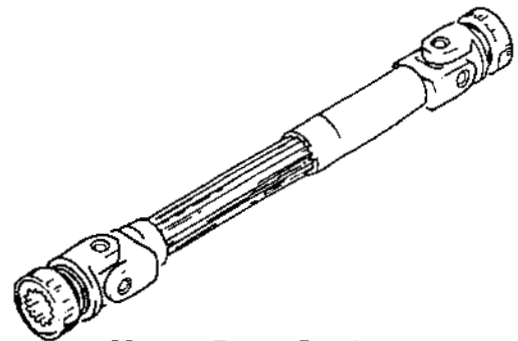

Mower Drive Shaft

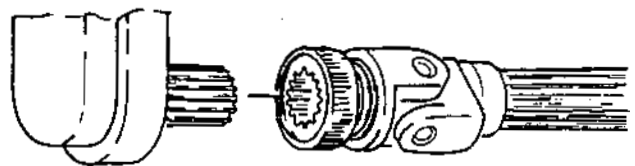

U-joint Attaches to Mid-PTO

Once the connection is made, shake the drive shaft to be certain that the locking collar is forward and completely locked.

INSTALLING MOWER

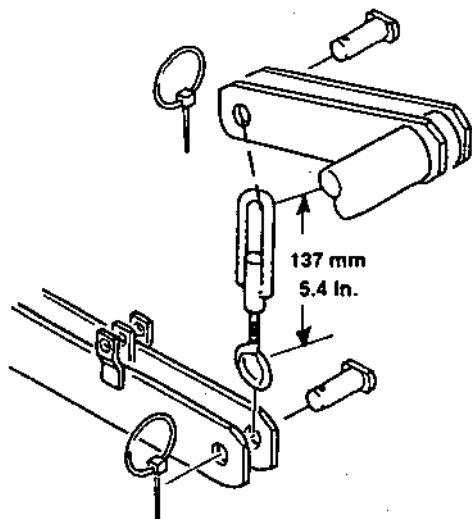

Lift Arms Fasten to Mower Deck

Fastening Lift Arms to Mower Deck

1. Screw the eye bolt into the lift eye and adjust to 137 mm (5.4 in) length.
2. Attach the eye bolt to the mower brackets with a clevis pin and secure it with a linchpin.
3. Pull down lift arm and align the oval hole of the lift joint in the clevis of the lift arm, insert a clevis pin and secure it with a linchpin.
4. Raise the mower slowly with the hydraulic position control to check for full travel with no interference.
5. Adjust lift joints so gauge wheels lift off the ground at the same time.

Checking Mower Lift With Loader Sub-Frame Installed

NOTICE If you have a front loader sub frame installed, you must use the following procedure to adjust the mower linkage to avoid damage to the deck or linkage.

1. Slowly move the Lift Selector Lever to the "UP" position to raise the deck. Immediately lower the deck at the first indication of resistance.
2. Check the clearance between the deck stops and the front loader sub frame. Adjust the clearance to 5 mm (0.20 in) by adjusting the left lift rod length (shortening the lift rod raises the deck).

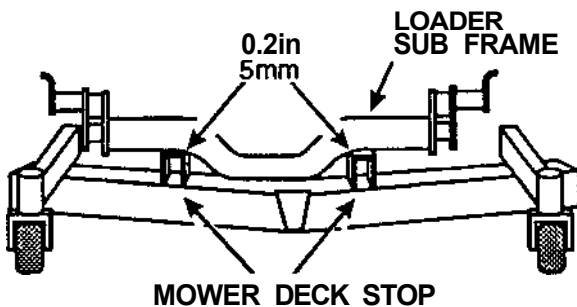

The fully raised position of the deck will be lower than normal with the loader sub frame installed. You will only be able to raise the deck to a maximum cutting height of 4 in.

DETACHING MOWER FROM TRACTOR

Detaching Front Links

NOTE: If mower deck hook is engaged to hold mower deck up, deck must be raised and hook released before mower can be detached.

1. Pull locking pins on mower wheels and set wheels so that mower is high as possible. This will make removing quick release pins on links easier.
2. Pull right and left front quick release pins by pulling back on pin and turning until spring pin catches and holds in slot in front link bracket. Hold front link and lower it to ground. Repeat for other side.

CAUTION Mower deck will descend when front links are released. Keep fingers and feet from being caught below the mower to avoid injury.

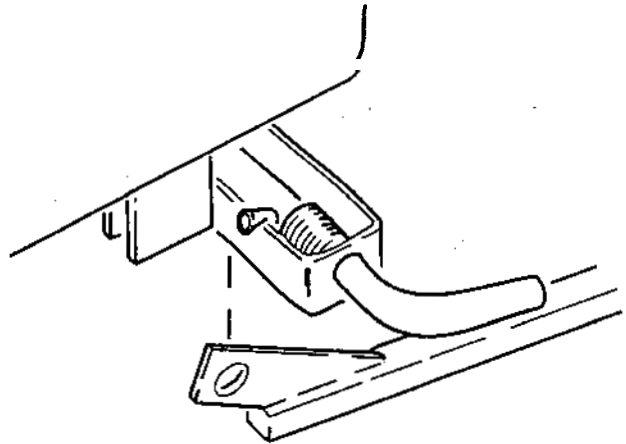

Front Mower Links Detach From Tractor

Detaching Rear Links

1. Pull locking pin on left rear link and draw it towards you to remove. If rear link cannot be detached easily, shake the mower back and forth with foot, until rear link comes loose.

NOTE: Be careful not to get your fingers caught between the rear arms of the lift plate assembly and the mower deck. Arms come down when pin is detached.

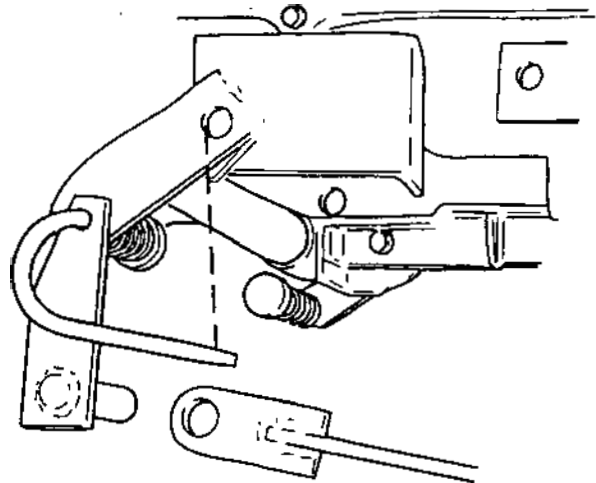

Rear Mower Links Detach From Tractor

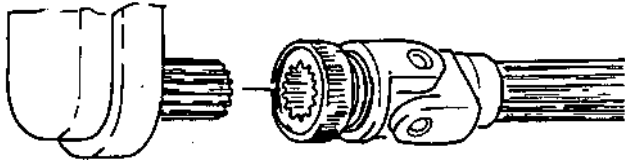

U-Joint Detaches From Mid-PTO

Detaching Mid-PTO and Mower Drive Shaft

1. With engine off, PTO selector set to "REAR" and key removed, reach under tractor and grasp the locking collar of the U-joint of the mower drive shaft.
2. Pull locking collar back (toward front of tractor) to release spline of Mid-PTO. Pull the U-joint away from the PTO, towards the mower to remove.

NOTE: If the locking collar is difficult to release, turning it clockwise and counterclockwise will help free it.

3. Make sure that U-joint is placed where it will not be crushed by tractor tires when tractor is backed over pulley covers.

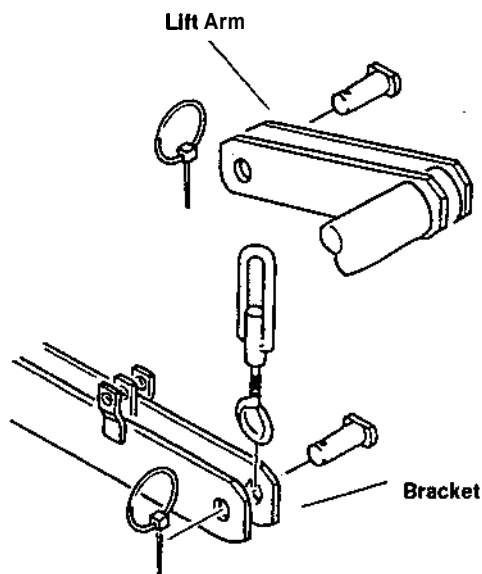

Lift Arms Fasten to Mower Deck

Detaching Lift Joints

⚠ WARNING Keep fingers clear of brackets when pulling pins as mower deck may drop slightly.

1. Pull pins attaching lift joints to lift plates brackets as illustrated.

NOTE: If hydraulic lift system is not fully down, pins may be under tension and mower deck may descend slightly. Make sure to keep fingers clear.

2. After detaching, temporarily replace clevis pins in brackets and secure with cotter pins to keep from losing or misplacing them. The lift joints should remain attached to the mower, not the lift arms.

INSTALLING MOWER

Moving Tractor Off Mower

1. Before detaching, chock front and rear wheels of mower as illustrated. Place triangular piece of wood in front of mower, aligned with pulley covers, to avoid having the mower slide as the tractor climbs over it.
2. Start the engine, move Lift Control Lever "UP", place the transmission range selector in "1" (A-4 models, select 4-wheel drive).
3. Move Lift Sector Lever to "UP" and raise lift arms to maximum position. Keeping engine at low idle speed, set main transmission to "REVERSE" (on 4-wheel drive models, move selector to 4-wheel drive position).
4. Making fine speed adjustments with accelerator, back the tractor off the mower, with front wheels passing over pulley covers.

NOTE: Make sure that the wheels pass over pulley covers to avoid damage to gear box, rear link or puncture of tires.

5. Switch off engine after moving tractor off mower. Set brakes.

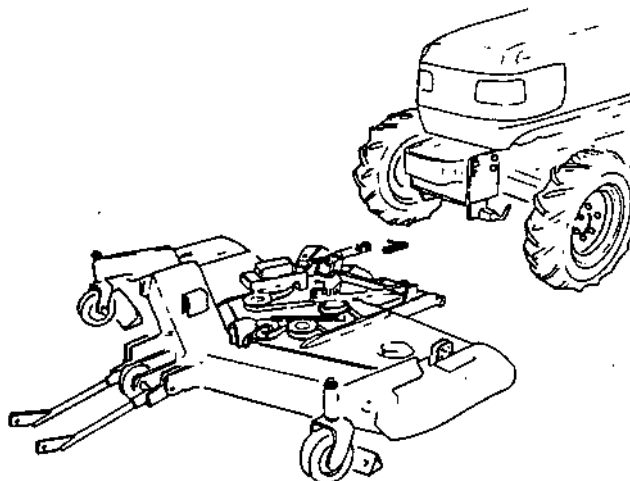

Front Wheels Chocked

OPERATION

Safety is a primary concern in the design and manufacture of our products. Unfortunately, our efforts to provide safe equipment can be wiped out by a single careless act of an operator.

In addition to the design and configuration of equipment, hazard control and accident prevention are dependent upon the awareness, concern, prudence and proper training of personnel involved in the operation, transport, maintenance and storage of equipment.

It has been said 'the best safety device is an informed, careful operator'. We ask you to be that kind of an operator.

The operator is responsible for the safe operation of this mower. The operator must be properly trained and qualified. Operators should be familiar with the mower and tractor and all safety practices before starting operation. Read the safety information on pages 4-7.

This mower is designed for lawn or grass mowing. It is not designed for rough conditions or heavy weed mowing. It is equipped with suction type blades for best results in lawn mowing.

Recommended mowing speed for most conditions is from two to five mph.

⚠ WARNING

- Do not allow children or unqualified persons to operate equipment.
- Keep bystanders away from equipment while it is in operation.
- Before working underneath, raise mower, install transport lock and block mower securely. Hydraulic system leak down and failure of mechanical or hydraulic system can cause equipment to drop.
- Keep all persons away from operator control area while performing adjustments, service or maintenance.
- Operate tractor mid-PTO at no more than 2400 RPM (maximum governed engine RPM).
- Make sure mower driveline spring-activated locking collar slides freely and the balls are seated in mid-PTO shaft groove.

⚠ CAUTION

- Stop mower and tractor immediately upon striking an obstruction. Turn off engine, remove key, inspect and repair any damage before resuming operation.
- Always wear relatively tight and belted clothing to avoid entanglement in moving parts. Wear sturdy, rough-soled work shoes and protective equipment for eyes, hands, hearing and head.

ADJUSTING CUTTING HEIGHT

Mower cutting height is raised, lowered, and maintained by adjusting caster and gauge wheels. Refer to figure and accompanying chart for approximate cutting heights.

Raise mower with tractor hydraulics to adjust gauge and caster wheels.

It is important that all three adjustments be the same. To set cutting height, match numbers shown in illustration. (Example: hole 2 in caster adjustment with hole 2 in gauge wheel adjustment, etc.)

Approximate Cutting Height	Position
1-1/2 in.	1
2-1/8 in.	2
2-3/4 in.	3
3-3/8 in.	4
4 in.	5

NOTICE Avoid very low cutting heights. Striking the ground with blades gives one of the most damaging shock loads a mower can encounter and, if this occurs repeatedly, it will cause damage to mower and drive.

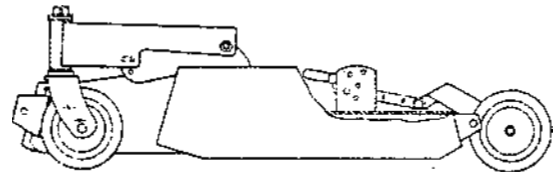
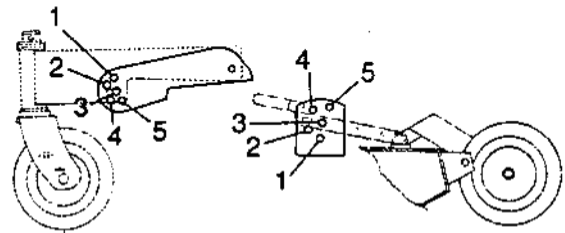

OPERATION

PRE-OPERATION CHECK LIST

⚠ WARNING

- Operate tractor mid-PTO at no more than 2400 RPM (maximum governed engine RPM).
 - You may not be able to stop the tractor safely if the clutch or brake pedal mechanisms are improperly adjusted, allowing them to contact mower components.
 - When the mower lift stops are installed as instructed in this manual, properly adjusted clutch and brake pedal mechanisms will not contact mower components. You should frequently check that the tractor clutch and brake pedal mechanisms are in adjustment.
 - If the clutch or brake pedal mechanisms can contact mower components, do not operate until properly adjusted.
1. Review and follow safety rules on pages 4-7.
 2. Do not operate mower unless belt shield and discharge chute are in place and securely fastened.
 3. Check that mower is properly and securely attached to tractor.
 4. Check to ensure blades are sharp, secure and properly installed. See Blade Condition on Page 38.
 5. Check that all hardware is properly installed and secured.
 6. Check to ensure spindles and caster wheels are lubricated .
 7. When attaching U-joint to tractor mid-PTO shaft, it is important that the spring-activated locking collar slides freely and the balls are seated in groove on mid-PTO shaft.
 8. Check mower cutting height and attitude adjustment. See Adjusting Cutting Height on Page 29.
 9. Raise mower carefully and check to be sure it does not come in contact with hydraulic lines.
 10. Remove grass and other foreign material from the top of the deck.

NOTICE Mower vibration tends to loosen bolts during operation. All hardware should be checked regularly to maintain proper torque. It is a good practice to check mower before each operation to ensure all bolts are secure.

Power for operating mower is supplied by tractor mid-PTO. Do not exceed tractor manufacturer's rated mid-PTO speed of 2400 RPM (maximum governed engine RPM). Know how to stop tractor and mower quickly in case of an emergency.

Should mower become plugged, causing belt to slip for over two seconds, maneuver equipment into a previously cut area and allow mower to clear accumulated material. Continue running at least two minutes, allowing pulleys to cool. Stopping the mower with belt in contact with a very hot pulley will bake and ruin belt.

⚠ CAUTION Stop mower and tractor immediately upon striking an obstruction. Turn off engine, remove key, inspect and repair any damage before resuming operation.

OPERATING TECHNIQUE

Proper ground speed will depend upon the terrain, the height, type and density of material to be cut.

Normally, ground speed will range from two to five mph. Tall dense material should be cut at a low speed; thin medium-height material can be cut at a faster ground speed.

Always operate tractor mid-PTO at maximum governed engine RPM. This is necessary to maintain proper blade speed and produce a clean cut.

Under certain conditions, tractor tires may roll some grass down and prevent it from being cut at the same height as the surrounding area. When this occurs, reduce your ground speed, but maintain maximum engine RPM. The lower ground speed will permit grass to at least partially rebound.

Under some conditions, grass will not rebound enough to be cut evenly. In general, lower cutting heights give a more even cut with less tendency to leave tire tracks. However, it is better to cut grass frequently rather than too short. Short grass deteriorates rapidly in hot weather and invites weed growth during growing seasons. Follow local recommendations for the suitable cutting height in your area.

When operating the mower, move the Lift Control Lever to the "DOWN" position. This will allow the mower to follow ground contours.

Tips

Extremely tall material should be cut twice. Set mower at a higher cutting height for the first pass. Then cut at desired height at 90° to the first pass.

Remember, sharp blades produce cleaner cuts and require less power.

Analyze area to be cut to determine the best procedure. Consider height and type of grass and terrain type: hilly, level or rough.

Plan your mowing pattern to travel straight forward whenever possible. Mow with uncut grass to the left. This will distribute the clippings over the cut area. Discharging clippings over uncut grass will cause a build-up and may prevent uniform cutting.

⚠ DANGER Do not operate mower unless discharge chute and belt shields are installed.

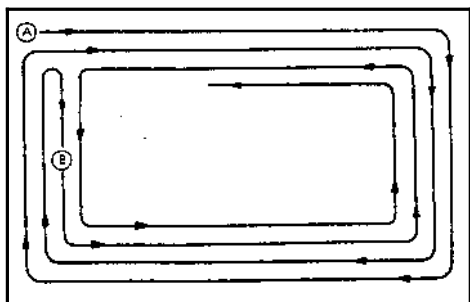

Small Area Cutting Pattern

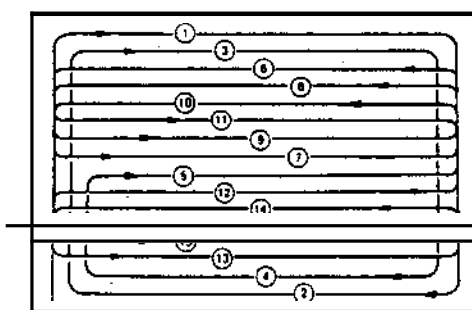

Large Area Cutting Pattern

CUTTING PATTERNS

These cutting patterns are only recommended for a flat, level lawn surface.

In a small area

First make 2 or 3 turns in a clockwise direction, then turn around and continue cutting in a counter-clockwise direction.

In a large area

The first round of cuts is the key to making a neat finish. First, make 2 or 3 turns in a clockwise direction. As you reach the center of the area, turn to the right and begin cutting in a counter-clockwise direction until you have finished the upper half of the area. Cut the grass in the remaining half in a counter-clockwise direction.

Mowing unsquare areas

If your mowing area is not square or four-sided, divide the area into several blocks so you can mow in a neat mowing pattern.

Overlapping on straightaways

Be sure that each mowing lane overlaps sufficiently. The recommended overlap width is between 4-6 inches or approximately the width of one of the mower's front tires.

Overlapping in curves and turns

When cutting in curves and turns, shift to a slower speed and be sure to overlap the previous cut by 20-50% or approximately half the width of the mower.

Uneven Terrain

⚠ WARNING

- Do not operate on steep slopes.
- Do not stop, start or change directions suddenly on slopes.
- Use extreme care and reduce ground speed on slopes and rough terrain. Watch for hidden hazards on the terrain during operation.

Pass diagonally through sharp dips and avoid sharp drops to prevent "hanging up" the tractor and mower. Practice will improve your skills in maneuvering rough terrain.

Take all possible precautions when leaving tractor unattended: disengage mid-PTO; set parking brake, stop engine, remove key and lower mower to ground.

OPERATING YOUR MOWER WITH OTHER EQUIPMENT

You may operate your MM60 mower with three-point hitch mounted attachments and with the FL6555 Front Loader sub frame only. You must not operate or install the mower while any other attachments are installed on the tractor.

CAUTION A minimum 20% of tractor and equipment weight must be on tractor front wheels with mower in transport position. Without this weight, tractor could tip over causing personal injury or death. The weight may be attained with front wheel weights, ballast in tires or front tractor weights. When attaining the minimum 20% weight on the front wheels, you must not exceed the Roll Over Protection Structure (ROPS) weight certification. Weigh the tractor and equipment. Do not estimate.

Using Three-Point Hitch Attachments

1. Start the engine and set Lift Control Lever to "UP" and raise the mower to maximum height. Turn Lowering Speed Control fully clockwise to lock lift arms in up position. Leave Lift Control Lever in "UP" position. Stop engine, set brake and remove keys.

CAUTION Make sure to turn Lowering Speed Control fully clockwise to lock hydraulic system before attaching mower deck hook. This prevents the mower deck from descending and causing injury to feet or hands.

2. Pull linchpin holding mower hook to mower hook bracket. Turn mower hook in adjusting pin so that it is long enough to reach projecting lockup pin on bracket attached to tractor frame as illustrated. Adjust the mower hook so that it fits TIGHTLY over the projecting lockup pin on tractor. This will minimize the backlash on the lockup pin when it supports the mower.
3. Slip mower hook over lockup pin, and secure with washer and linchpin removed from mower hook bracket. Insert linchpin from front to back to lock properly.

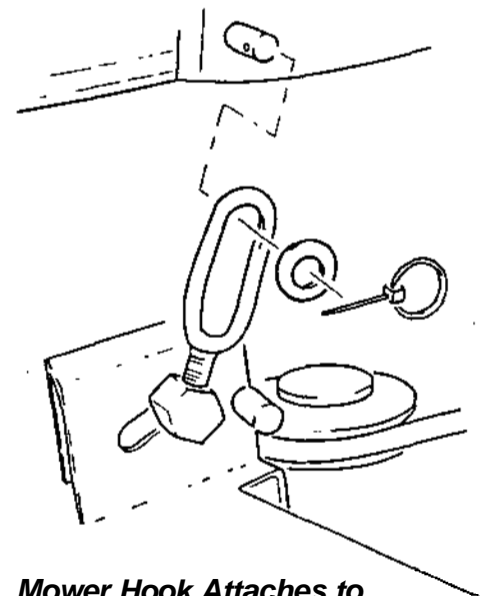
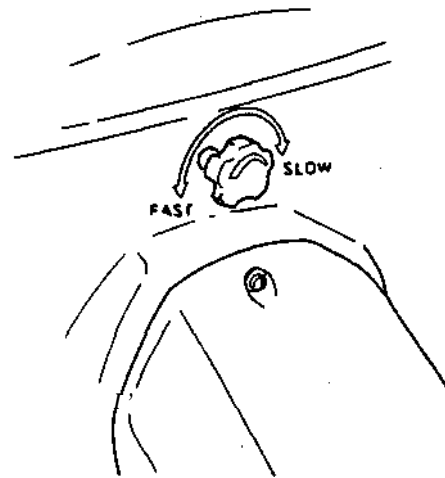

Mower Hook Attaches to Mower Hook Bracket

INSTALLING MOWER

4. Place other attachment on Rear Three Point Hitch . Mower deck will be held out of the way by mower deck hook.

NOTE: The mower deck will be raised a small amount when Lift Control Lever in fully “UP” position. This is due to the play in the mower deck hook and will not affect the operation of the Rear Three Point Hitch or attachment.

Unlocking Mower Hook

1. Start engine and set Lift Control Lever on “UP” to raise lift arms to maximum position. Turn off engine, turn Lowering Speed Control fully clockwise to lock hydraulic system and set brakes.
2. Remove clevis pin and use tool to pull mower hook off of lockup pin. Use caution since hook may be under pressure.

⚠ WARNING Mower hook may be under tension. Set Lift Control Lever to “UP” and raise arm to take tension off hook before detaching. Turn engine off so that lift arm cannot move. Wear heavy gloves and keep fingers away from lift arms to avoid injury.

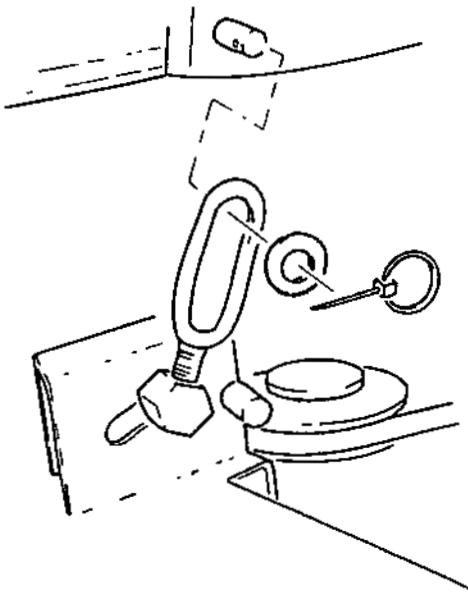

Using Rear Three Point Hitch with Mower Detached While the Mower Lift Linkage is Still Installed

1. Detach mower as described below.
2. Start engine and set Lift Control Lever on "UP" to raise lift arms to maximum position. Turn off engine, turn Lowering Speed Control fully clockwise to lock hydraulic system and set brakes.

NOTE: Block the lift plate to its full UP position.

3. Pull pin from projecting bracket at top of left hand lift rod, and remove as illustrated to release lift chain. Hold chain so that it does not fall.
4. Attach lift chain to projecting chain rest pin on the Roll Over Protection System. Secure with washer and cotter pin. **MAKE SURE TO RETAIN CLEVIS PIN IN SAFE PLACE TO BE ABLE TO RE-ATTACH CHAIN TO LIFT ROD.**
5. Install attachment as needed.

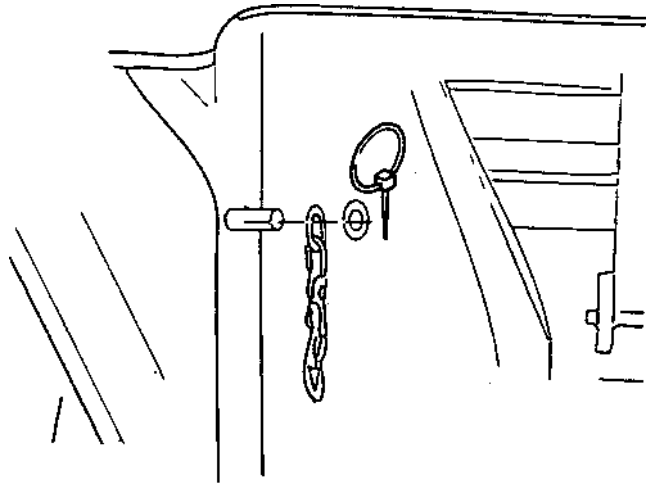

OWNER SERVICE

The information in this section is written for operators who possess basic mechanical skills. Should you need help, your dealer has trained service technicians available. For your protection, read and follow all safety information in this manual.

⚠ WARNING

- Before working underneath, raise mower, install transport lock and block mower securely. Hydraulic system leak down and failure of mechanical or hydraulic system can cause equipment to drop.
- Keep all persons away from operator control area while performing adjustments, service or maintenance.
- Lower mower to ground or block securely, turn tractor engine off, remove key and disconnect mower driveline from tractor PTO before performing any service or maintenance.

⚠ ACTION Always wear relatively tight and belted clothing to avoid entanglement in moving parts. Wear sturdy, rough-soled work shoes and protective equipment for eyes, hands, hearing and head.

LUBRICATION INFORMATION

Do not let excess grease collect on or around parts, particularly when operating in sandy areas.

The accompanying illustration shows lubrication points. The chart gives the frequency of lubrication in operating hours, based on normal operating conditions. Severe or unusual conditions may require more frequent lubrication. Some reference numbers have more than one location; be sure you lubricate all locations.

In addition to the lubrication points shown, at least once a year, oil the six mower lift pivot points.

Use a lithium grease of #2 consistency with a MOLY (molybdenum disulfide) additive for all locations. Be sure to clean fittings thoroughly before attaching grease gun. When applied according to the lubrication chart, one good pump of most guns is sufficient.

Use SAE 90W gear lube in the gearbox. Check gear box daily for evidence of leakage at both seals and the gasket between the housing and cover. If leakage is noted, repair immediately. There may be a small amount of lube emitted from the vent plug; this is not considered leakage. Check lube level every 50 hours by removing the vent plug and checking the gauge on the bottom of the vent plug. The oil level should show 1 in. on the gauge. You may also check the oil by using an Allen wrench to remove the level plug in the front of the gearbox. Do not over lubricate. Over-filling the gearbox will cause the excess gear lube to blow out vent plug. The gear lube could then ruin the belt.

Drive Shaft Lubrication

Lubricate the drive shaft slip joint every 8 operating hours. Failure to maintain proper lubrication could result in damage to U-joints, gearbox and drive shaft.

Lower mower to ground and apply a bead of grease all around the male half where it meets the female half. Raise and lower mower several times to distribute grease.

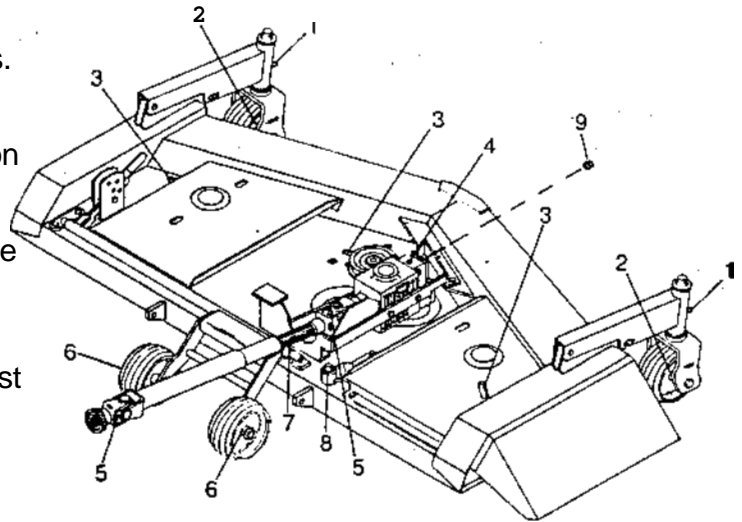

Lubrication Points

Ref. No.	Item Description	Frequency
1.	Caster Pivot	8 hrs
2.	Caster Wheel	8 hrs
3.	Blade Spindles	24 hrs
4.	Gearbox- Check level (check for leaks daily)	50 hrs
5.	Driveshaft U-joints	8 hrs
6.	Rear Gauge Wheels	8 hrs
7.	Driveshaft Slip Joint	8 hrs
8.	Spring Take-up Pivot Arm (30W Oil)	24 hrs
9.	Oil Level Plug	50 hrs

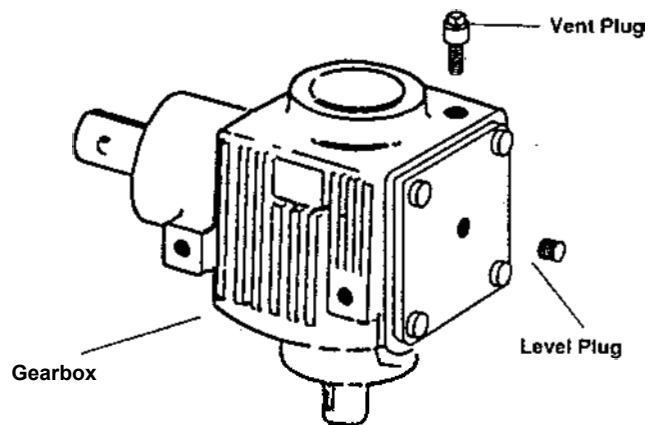

Gear Box

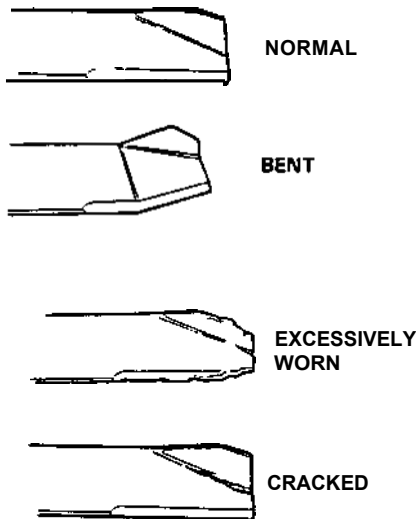

Blade Condition

BLADE INSPECTION

Before each use, check each mower blade for damage or abnormal wear.

1. Start the engine and raise the mower deck fully with the Lift Control Lever set to "UP". Turn the Lowering Speed Control knob fully clockwise to prevent descent. Do not overtighten the knob.
2. Stop the engine and remove the ignition key. Block deck with wood block to prevent lowering.
3. Inspect each of the blades for cracks, bending or signs of wear. The right and center blades can be seen under the right side of the mower deck. The left blade can be seen from under the left front edge of the mower deck. Turn the blades 180° to inspect the opposite side.

NOTE: If any of the blades show signs of damage or excessive wear, a more thorough inspection is necessary. A dull blade can be sharpened, but a blade that is worn out, bent, cracked or otherwise damaged must be replaced.

⚠ WARNING

- Severe personal injury can result if a piece of blade breaks off and is thrown from under the mower deck.
- Never operate the tractor with a worn or damaged blade.
- Never operate the tractor with a blade that is cracked or notched at the base of its upturned edge.

BLADE SERVICING

Inspect blades for condition and proper installation each time before operation. Replace any blade that is bent, excessively nicked, worn or has any other damage. Small nicks can be ground out when sharpening.

Blade Removal

For right and left spindles, install spindle lock wrench (5) through belt shield and into holes in spindle pulley as shown. Remove bolt which has RIGHT HAND THREADS. Remove cup washers, washer and blade.

On the center spindle use blade wrench handle. The handle will rotate against gearbox stand when blade bolt is removed.

Shoulder washer will not normally come off unless intentionally removed.

Blade Installation

1. Install spindle lock wrench through belt shield and into holes in spindle pulley as shown.
2. Install shoulder washer (if removed) small end up. Make sure blade cutting edge is positioned to lead in clockwise rotation, as viewed from top of mower.
3. Excessive blade slipping can cause cup washers to burn and lose their clamping force. Inspect cup washers to determine if they are burned or have lost their clamping force. Replace as necessary.

CAUTION Use a new Nylok blade bolt when you replace the blade. Do not substitute any other bolt for the special blade bolt. It is self-locking, meeting the non-loosening requirements for this application.

4. Install two cup washers on bolt. Install washer and blade on bolt. Remember bolt has right hand threads; install bolt and blade assembly into spindle. Torque bolt to 23.5 kg/m (170 ft/lbs). Remove spindle lock wrench from pulley and shield.

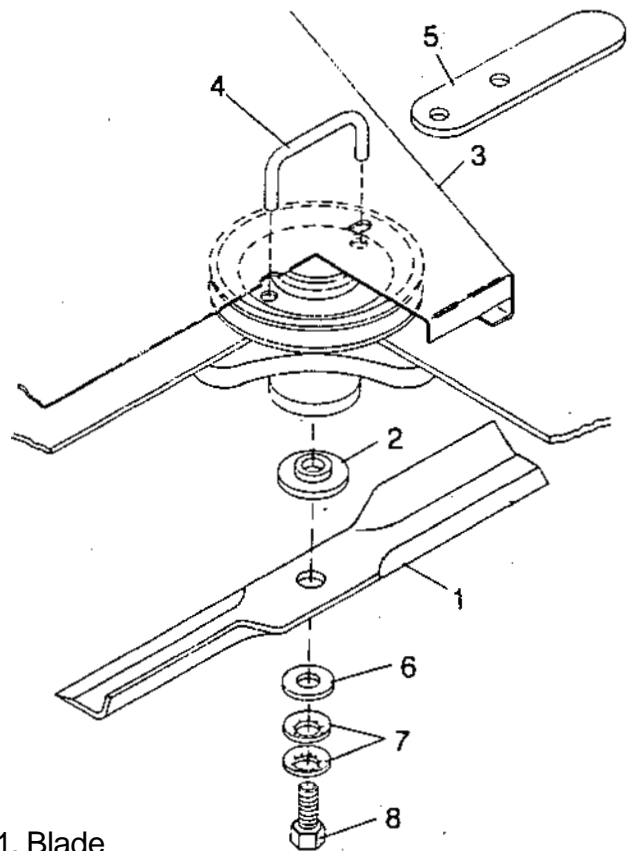

1. Blade
2. Shoulder washer
3. Left belt shield
4. Spindle lock wrench
5. Spindle lock wrench handle
6. 5/8" Standard flat washer
7. Cup washers
8. Blade bolt, special Nylok (right hand threads)

Blade Assembly

MAINTENANCE

CAUTION Your dealer can supply genuine replacement blades. Substitute blades may not meet original equipment specifications and may be dangerous.

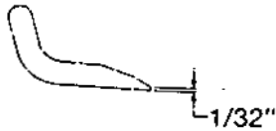
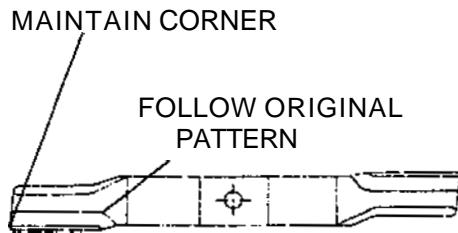

Blade Sharpening

Blade Sharpening

1. Remove blades.
2. Always sharpen both ends at the same time to maintain balance. Follow original sharpening pattern. Do not sharpen blade to a razor edge. Leave from $\frac{1}{32}$ in. to $\frac{1}{16}$ in. blunt edge. Do not sharpen the back side of the blade.

NOTICE When sharpening blades be sure to balance them. Unbalanced blades will cause excessive vibration which can damage blade spindle bearings. Vibration may also cause structural cracks in mower components.

REPLACING BLADE BELT

Removing Blade Belt

1. Remove right and left pulley covers (as viewed from rear of mower). Right cover is held on by two bolts and one nut, left cover by two bolts. Retain bolts and nuts to replace cover.
2. Grasp belt with both hands on either side of the rear center idler pulley (see illustration for location). Pull back towards you to create enough slack to slip belt off pulley.
3. Belt will now be quite slack and can easily be removed from other pulleys, including tensioner arm pulley (illustrated).
3. To remove belt from gearbox driven pulley, remove the two bolts holding front of the gearbox mount to mower deck, and loosen the two bolts on the rear of the gearbox mount. Tip the gearbox up and slip the belt off the gearbox pulley and slide it underneath the gearbox to completely remove.

Installing Blade Belt

1. Remove the two bolts holding front of gearbox mount to mower deck, and loosen the two rear bolts (if not done previously).
2. Tilt gearbox up and slide belt underneath gearbox. Fit into pulley V-groove and reinstall bolts.
3. Fit belt over all except center rear idler pulley. Make sure that belt goes behind pivot on tensioner arm (belt makes a bend at this point).
4. Grasp belt with both hands, and pull back towards you. Slip belt over center idler pulley.
5. Reinstall left and right pulley covers. Do not operate without pulley covers installed.

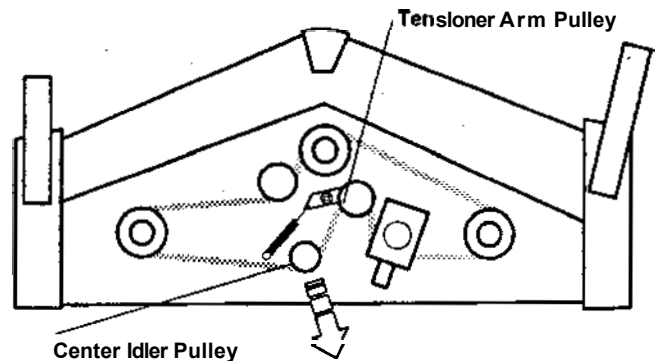

Belt Assembly

DEALER LEVEL MAINTENANCE

The information in this section is written for dealer service personnel. The repair described herein requires special skills and tools. If your shop is not properly equipped or your mechanics are not properly trained in this type of repair, you may be time and money ahead to replace complete assemblies.

⚠ WARNING

- Before working underneath, raise mower, install transport lock and block mower securely. Hydraulic system leak down and failure of mechanical or hydraulic system can cause equipment to drop.
- Keep all persons away from operator control area while performing adjustments, service or maintenance.
- Lower mower to ground or block securely, turn tractor engine off, remove key and disconnect mower driveline from tractor PTO before performing any service or maintenance.

⚠ CAUTION Always wear relatively tight and belted clothing to avoid entanglement in moving parts. Wear sturdy, rough-soled work shoes and protective equipment for eyes, hands, hearing and head.

⚠ WARNING Make sure mower driveline spring-activated locking collar slides freely and the balls are seated in mid-PTO shaft groove.

SPINDLE REPAIR

Blade Spindle Removal

1. Remove blade from spindle. (See Blade Removal on Page 39.)
2. Remove belt shield.
3. Remove belt from pulleys.
4. Remove bolt and flat washer from top of spindle shaft.
5. Disassemble split taper bushing (located on top of pulley) by removing the two bolts and inserting them into the threaded holes in bushing flange. Tighten bolts alternately to remove split taper bushing. Remove pulley.
6. Remove three bolts attaching spindle to mower frame and remove spindle.

Spindle Repair Tips

1. As a reference point, the top of spindle housing is the short portion.
2. To minimize wear, bearing cups, cones and sleeves are press fit to shaft and will require a press or similar device for removal.
3. When disassembling, support housing casting to prevent damage.
4. Remove bearing cups by placing a punch in housing slots and drive cup out. Alternate punch positions from side to side. Use care to prevent housing damage.
5. Bore-tite™ sealant is used on the outer diameter of the seals. Substitute seals may not meet original equipment specifications and could cause leakage.

Bore-tite is a registered trademark of Chicago Rawhide Industries.

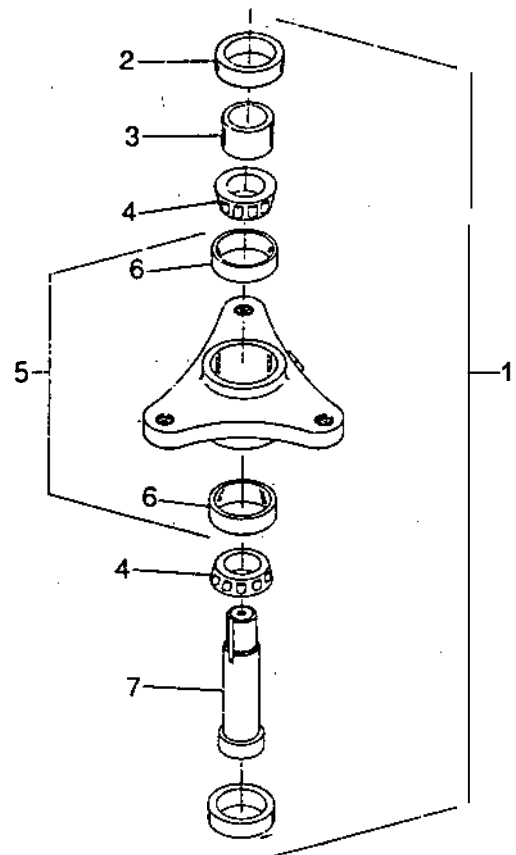

1. Spindle assembly
2. Seal
3. Sleeve
4. Bearing cone
5. Housing and cups
6. Cup
7. Shaft

Spindle Assembly

Blade Spindle Disassembly

1. Support spindle in a press and push shaft down through housing.
2. Remove seals from housing.
3. Remove bearing cups from housing as described in Spindle Repair Tips section.
4. Remove bearing cone from shaft.

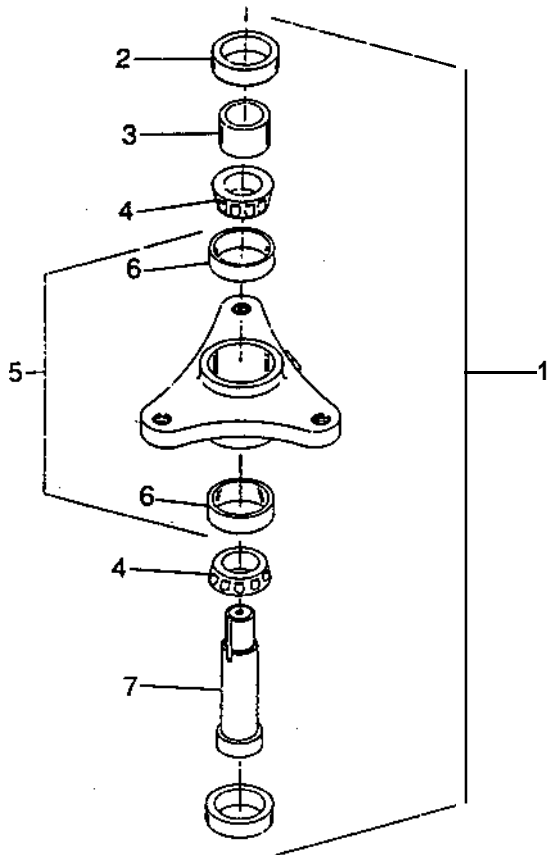

1. Spindle assembly
2. Seal
3. Sleeve
4. Bearing cone
5. Housing and cups
6. Cup
7. Shaft

Spindle Assembly

Blade Spindle Assembly

1. Bearing cups and cones are designed to work together. It is important to position them so bearing cone taper mates with bearing cup taper.
2. Lubricate new cups with a light oil. Place them in spindle housing so they will mate with cones. Seat cups against machined shoulder of housing with a press or by placing a large drift on the flat lip and driving them into housing.
3. Place bottom bearing cone onto spindle shaft with taper up. Seat on bottom shoulder of shaft with a press.
4. Insert shaft and bearing cone assembly through bottom of housing. Fill housing cavity with a lithium grease of #2 consistency with a MOLY (molybdenum disulfide) additive.
5. Place top bearing cone on shaft to mate with top bearing cup.

NOTICE Bearing adjustment is set by pressing sleeve against bearing cone until proper adjustment is attained.

6. Install sleeve on shaft and press sleeve and bearing cone onto shaft until all bearing free play is removed and there is a slight drag (similar to adjusting the front wheel bearings on an automobile). Check by spinning spindle. It should turn freely.
6. Be careful not to over-tighten bearings. Proper bearing adjustment is essential to good bearing life.
7. Should you over-tighten bearings, hold spindle housing and rap spindle shaft with a lead hammer to loosen bearings. Readjust bearings until proper setting is obtained.

NOTICE Improper positioning of seals can cause seal failure.

8. Proper seal installation is important. An improperly installed seal will leak and could cause bearing failure.
9. Pull the rubber portion of seal back and locate spring.

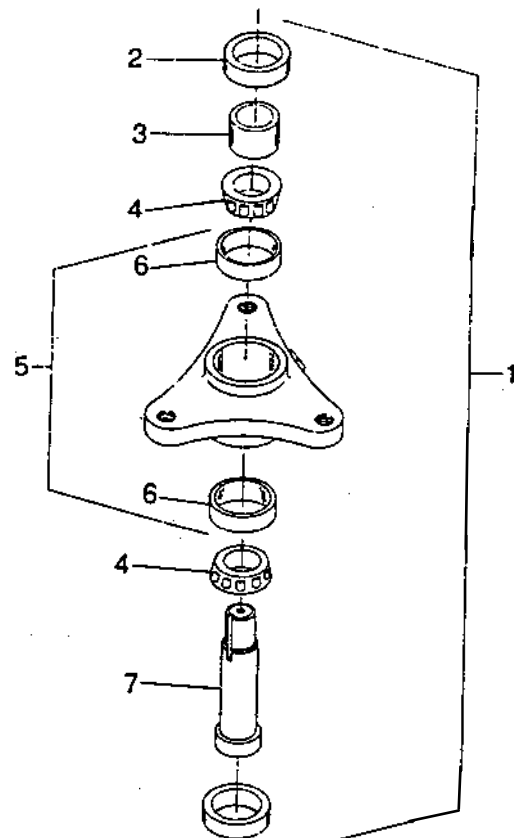

1. Spindle assembly
2. Seal
3. Sleeve
4. Bearing cone
5. Housing and cups
6. Cup
7. Shaft

Spindle Assembly

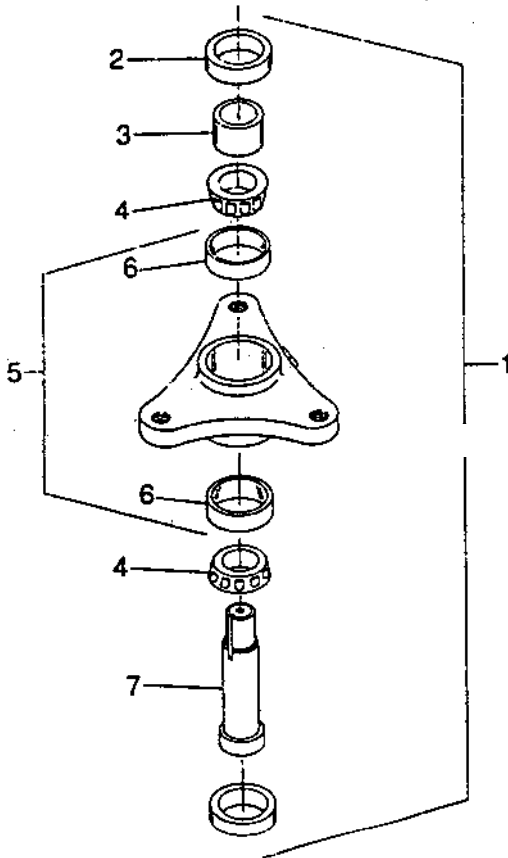

- 1. Spindle assembly
- 2. Seal
- 3. Sleeve
- 4. Bearing cone
- 5. Housing and cups
- 6. Cup
- 7. Shaft

Spindle Assembly

10. Apply a thin coat of lubricant to bottom seal (2) and install with spring up toward center of housing.
11. Place bottom seal squarely on housing. Select a piece of pipe or tubing with an OD that will set on outside edge of seal. A tube that is too small will bow seal cage.
12. Carefully press seal into housing, preventing distortion to metal seal cage. Seal should seat firmly and squarely against machined shoulder in housing.
13. Make sure seal lip did not roll under. Distortion to seal cage or damage to seal lip will cause seal to leak. Damaged seals must be replaced.
14. Apply a thin coat of lubricant to top seal (2) and install with spring up away from center of housing. Top seal should be flush with top of housing.
15. Lubricate spindle with a lithium grease of #2 consistency with a MOLY (molybdenum disulfide) additive. Vent top seal with a blunt edged tool such as a letter opener while filling with grease. Rotate housing on spindle shaft, checking for free movement.

Blade Spindle Installation

1. Insert spindle through bottom of mower deck and install three mounting bolts. Be sure to position grease fittings toward lubrication access areas. Refer to lubrication chart.

NOTICE Pulley installation sequence is very important for bearing life. Follow the sequence exactly.

2. Install pulley and split taper bushing with integral key on spindle shaft. Install bolt and flat washer in top of spindle shaft. Torque this bolt to 1.7 kg/cm (12 ft/lbs), then alternately tighten split taper bushing bolts to 1.7 kg/cm (12 ft/lbs).

UNIVERSAL JOINT REPAIR

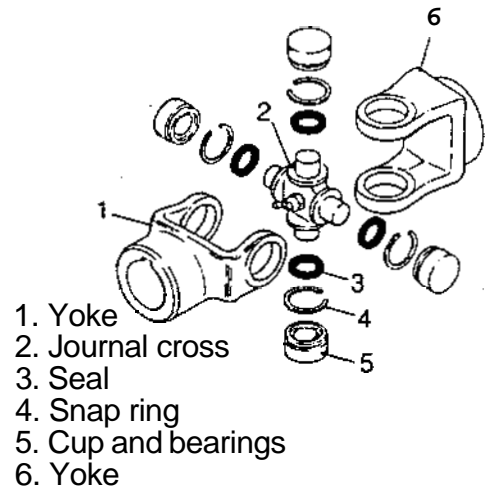

Universal Joint Assembly

Disassembly

1. Remove snap rings from inside of yokes in four locations as shown.

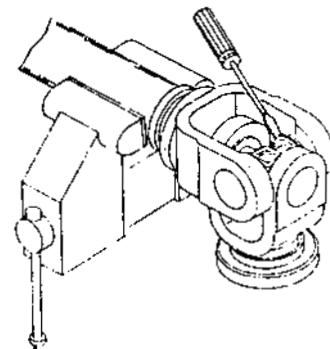

2. With snap rings removed, support drive in vise, hold yoke in hand and tap on yoke to drive cup out of yoke.

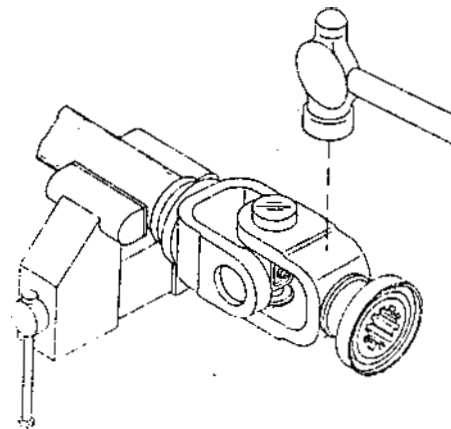

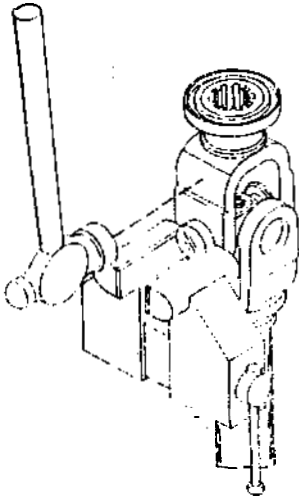

3. Clamp cup in vise as shown and tap on yoke to completely remove cup from yoke. Repeat steps two and three for opposite cup.

4. Place universal cross in vise as shown and tap on yoke to remove cup. Repeat step three for final removal. Drive remaining cup out with drift and hammer.

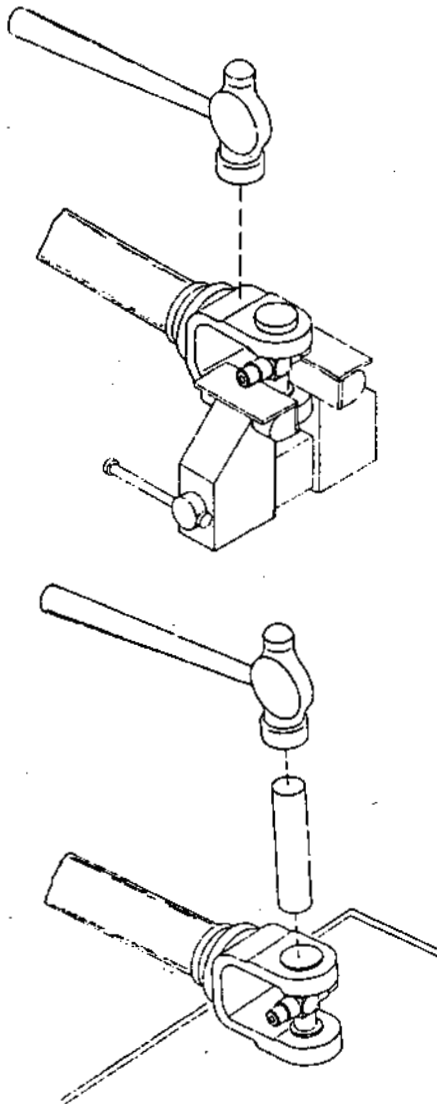

Assembly

1. Place seals securely on bearing cups. Insert cup into yoke from outside and press on with hand pressure as far as possible. Insert journal cross into bearing cup with grease fitting away from shaft. Be careful not to disturb needle bearings. Insert another bearing cup directly across from first cup and press in as far as possible with hand pressure.
2. Trap cups in vise and apply pressure. Be sure journal cross is started into bearings and continue pressure with vise, squeezing in as far as possible. Tap yoke to aid in process.
3. Seat cups by placing a drift (slightly smaller than the cup) on cup and rapping with hammer. Install snap ring and repeat on opposite cup.
4. Repeat steps one and two to install remaining cups in remaining yoke.
5. Move both yokes in all directions to check for free movement. Should movement be restricted, rap on yokes sharply with a hammer to relieve any tension. Repeat until both yokes move in all directions without restriction.

GEARBOX MAINTENANCE

Read this complete section before starting any repair. Many steps are dependent on each other.

1. Gearbox bearings, gears and shafts have an interference press fit. Gearbox repair is limited to seal; gasket and vent plug replacement.
2. Always maintain correct gear lube level in gearbox. Be sure proper vent plug is installed.
3. Troubleshooting is an important part of gearbox maintenance. Check for leakage and bad bearings.
4. Leakage is a very serious problem and must be corrected immediately or damage to gearbox and belt will result. Remove gearbox from mower to repair leakage problems.
5. Leakage may be caused by a vent plug not venting. To check vent plug operation, remove plug and apply low air pressure to opening in side of plug. Check to make sure it is venting out of the top.
6. Operating gearbox with improper lube level may also cause seals to leak. Also check for housing cracks. If any of these conditions exist, correct them, clean area where leakage was evident, return mower to service and check to make sure leakage has been stopped.
7. Bearing maladjustment or failure is indicated by noise and excessive side and end play in gear shafts. If noted, replace the gearbox.

Removing Gearbox from Mower

1. Disconnect drive shaft and remove key. Remove belt and remove gear stand from mower.
2. Turn gear stand over. There are two set screws in the split taper bushing; remove them. Insert one set screw into the threaded bushing hole and tighten to force bushing and pulley apart.
3. Remove gearbox from stand.

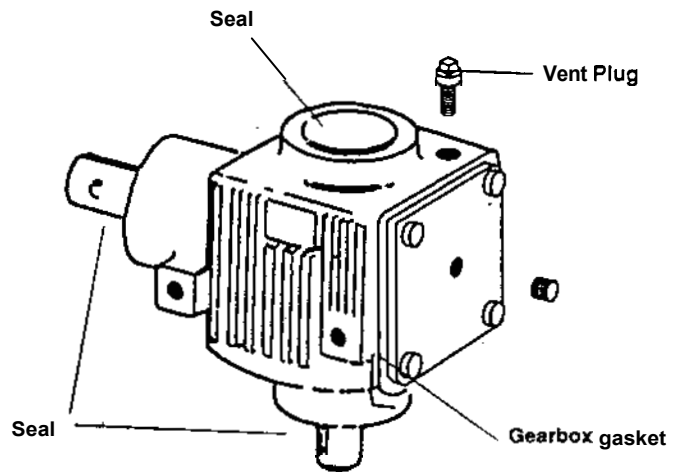

Gear Box

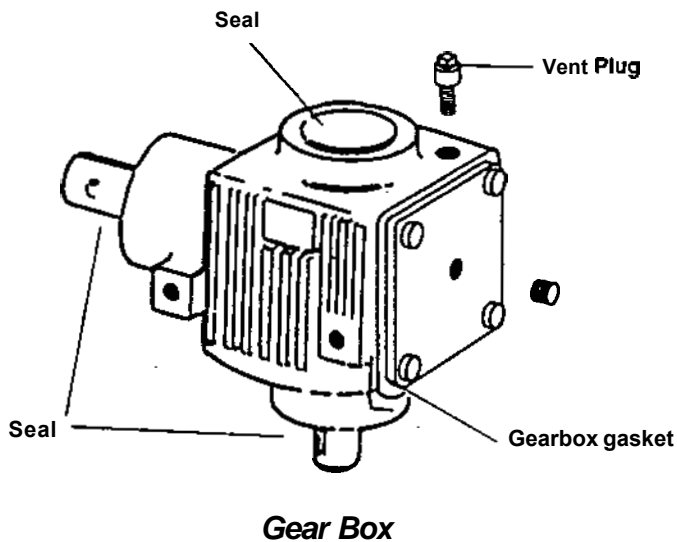

Leakage Repair

1. Bore-tite™, a sealant, is used on the outer diameter of the seals. Substitute seals may not meet original equipment specifications and could cause leakage.
2. Clean gearbox exterior to remove all foreign material. When opening, use care to prevent foreign material from entering gearbox.
3. To repair horizontal seal, vertical shaft, or leakage between cover and gearbox, remove vent plug and drain gear lube from box. Remove leaking seal and replace (refer to Seal Installation). Use care to prevent rolling seal lip under. Replace gasket between cover and gearbox.

Seal Installation

Proper seal installation is important. An improperly installed seal will leak and could result in bearing failure.

1. Clean areas in housing where seal outer diameter seats. Inspect gear shafts. Pay specific attention to areas where seals seat. Check for cracks, grooves, nicks or bumps. Replace housing or shaft if damage cannot be repaired by resurfacing with emery cloth.
2. Lubricate seal lip and carefully guide over shaft using a blunt tool such as a letter opener. Be careful not to roll seal lip under. Do not use a knife as it will nick and ruin seal.
3. Place seal squarely on housing (spring-loaded lip toward inside of gearbox). Select a seal driver, a piece of pipe or tubing with an OD that will set on outside edge of seal but will clear housing. A driver that is too small will bow seal cage and ruin seal.
4. Carefully press seal into housing, preventing distortion to metal seal cage. Seat vertical seal flush with housing and horizontal seal against shoulder in housing.
5. Distortion to seal case or damage to seal lip will cause seal to leak. Remove and replace seals damaged in installation.
6. Check for proper vent plug operation and fill gearbox with 8 oz. of SAE 90W gear lube.

Drive Pulley Installation

1. Install drive pulley with split taper bushing on gearbox vertical shaft. Make sure key and keyways are aligned.
2. Position centerline of drive pulley 0.98 & 0.030 in. above mounting surface of gearbox stand as shown. This is a very critical dimension and must be held. Alternately tighten split taper bushing set screws to 2 kg/m (14 ft/lb). Check mounting distance to make sure it is correct.

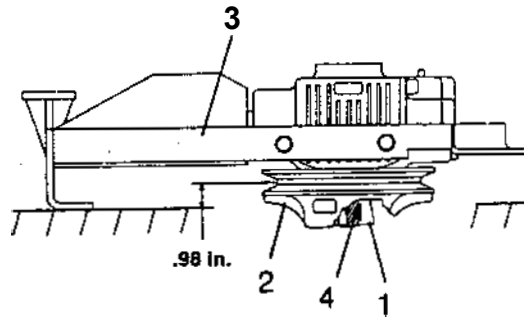

1. Split taper bushing
2. Drive pulley
3. Gearbox stand
4. Key

Drive Pulley Assembly

STORAGE

STORAGE

1. Remove the mower deck from the tractor.
2. Turn the mower deck upside down. Clean the underside of the deck with water, and dry thoroughly.
3. For longer service and greater efficiency, keep the underside of the mower housing clean and free of accumulated grass clippings by washing it down with a hose after use and/or cleaning it with a wire brush and scraper. Remove any rust and apply a rust-resistant paint. Cleaning and rust prevention are especially important before seasonal storage.

NOTICE Washing the deck directly after use can cause premature bearing wear. Allow the deck to cool before washing, then run the deck to remove any excess moisture.

PROBLEM

SOLUTION

BELT SLIPPAGE

- | | |
|--|--|
| 1. Mower overloading; material too tall or heavy | 1. Reduce tractor speed but operate Mid-PTO at 2400 rpm. Cut material twice: one high pass, then mow at desired height, Cut a partial swath. |
| 2. Oil on belt from over-lubrication | 2. Be careful not to over-lubricate. Clean lubricant from belt and pulleys with clean rag. Replace oil-soaked belt. |
| 3. Belt hung up or rubbing | 3. Check belt for free travel in pulleys and belt guides. Check under mower and around blade spindle shafts for wire, rags or other foreign material. Clean all material from under mower. |
| 4. Belt or pulleys worn out | 4. If belt rides in bottom of pulley groove, either belt or pulley is worn and must be replaced. |

FRAYED EDGES ON COVER

- | | |
|-------------------------------------|---|
| 1. Belt misaligned or rubbing guide | 1. Re-align belt or guide. Be sure belt doesn't rub any other part while running. |
|-------------------------------------|---|

BELT ROLLOVER

- | | |
|-----------------------|--|
| 1. Damaged belt | 1. Lay belt flat on floor. If belt does not lie flat (has humps or twists), indicating broken or stretched cords, it must be replaced. |
| 2. Worn pulley groove | 2. Replace pulley. |

BELT DAMAGE

- | | |
|--|------------------|
| 1. Rollover, high shock loads or installation damage | 1. Replace belt. |
|--|------------------|

BELT BREAKAGE

- | | |
|------------------------|--|
| 1. High shock loads | 1. Avoid abusive mowing. Avoid hitting the ground or obstructions. |
| 2. Belt came off drive | 2. Check drive alignment for foreign material in grooves. Avoid hitting solid objects or ground. |

TROUBLESHOOTING

PROBLEM

SOLUTION

POOR FINISHING/APPEARANCE

- | | |
|-----------------------------------|--|
| 1. Tractor speed too fast | 1. Shift to lower gear. |
| 2. Grass accumulation inside deck | 2. Clean deck underside. |
| 3. Dull Blade | 3. Have the blade sharpened or replace it. |
| 4. Tires improperly inflated | 4. Check the tire inflation. |
| 5. Mower not level | 5. Check the blade height. |
| 6. Wrong mower deck height | 6. Change to proper height. |
| 7. Engine speed too low | 7. Run at full throttle. |

BLADES DO NOT ROTATE

- | | |
|------------------------------------|--|
| 1. Blade drive belt worn or broken | 1. Replace with new belt. |
| 2. Mid PTO not selected | 2. Check PTO Selector Lever position |
| 3. Faulty PTO clutch or worn disk | 3. See your authorized HONDA Multi-purpose Tractor dealer. |

CLOGGED MOWER DECK DISCHARGE CHUTE

- | | |
|-------------------------|--|
| 1. Wrong blade | 1. Use genuine HONDA blade or equivalent. |
| 2. Deck too low | 2. Raise deck and adjust deck height properly. |
| 3. Engine overloaded | 3. Operate at full throttle. Use lower speed range. Set mower deck higher than desired height for first pass, then cut to desired height on second pass. |
| 4. Lawn wet or watered | 4. Allow to dry before cutting. |
| 5. Lawn too tall | 5. Set mower deck higher than desired height for first pass, then cut to desired height on second pass. |
| 6. Engine speed too low | 6. Run at full throttle. (Do not exceed 2400 rpms on Mid-PTO.) |

GRASS CUT TOO SHORT

- | | |
|-----------------------------|---------------------------------|
| 1. Cutting height too low | 1. Increase to proper height. |
| 2. Tractor speed too high | 2. Lower to proper speed. |
| 3. Uneven surface | 3. Change cutting pattern. |
| 4. Rough and uneven surface | 4. Adjust with height adjuster. |

EXCESSIVE VIBRATION

- | | |
|--|--|
| 1. Unbalanced blades | 1. Adjust balance. |
| 2. Driveblade belt damaged | 2. Replace. |
| 3. Pulley(s) damaged or out of alignment | 3. See your authorized HONDA multi-purpose tractor dealer. |
| 4. Lack of gearbox lubricant | 4. Lubricate with SAE 90 weight gear lubricant |

ENGINE SPEED DROPS EXCESSIVELY UNDER LOADS

- | | |
|--|--|
| 1. Engine speed too low | 1. Run at full throttle. (Do not exceed 2400 rpms on Mid-PTO.) |
| 2. Tractor speed too fast | 2. Lower to proper speed range. |
| 3. Pebbles or other foreign matter are stuck in mower deck | 3. Remove. |

SPECIFICATIONS

Overall length	1345 mm (53.8")
Overall width	1820 mm (72.8")
Mowing width	1500 mm (60")
Weight (including linkage)	140 kg (280 lbs)
Tractor mid-PTO operating speed	2,400 rpm maximum
Cutting height range	1-1/2" to 4"
Number of blades	3
Max. lifting height	6" to blade face (4" w/ FL6555 sub frame)
Caster wheels	3-1/4" x 6-11/4"
Mower frame thickness	8 GA deck

WARRANTY SERVICE

OWNER SATISFACTION

Your satisfaction and goodwill are important to your dealer and to us. All HONOA warranty details are explained in the Distributor's Limited Warranty. Normally, any problems concerning the product will be handled by your dealer's service department. If you have a warranty problem that has not been handled to your satisfaction, we suggest you take the following action

- Discuss your problem with a member of dealership management. Often complaints can be quickly resolved at that level. If the problem has already been reviewed with the Service Manager, contact the owner of the dealership or the General Manager.
- If your problem still has not been resolved to your satisfaction, contact the Power Equipment Customer Service Department of American Honda Motor Co., Inc.

AMERICAN HONDA MOTOR CO., INC.
Power Equipment Customer Service Dept.
Duluth, Georgia 30136-9421
Telephone: (404) 497-6400

We will need the following information in order to assist you:

- Your name, address and telephone number
- Product model and serial number
- Date of purchase
- Dealer name and address
- Nature of problem

After reviewing all the facts involved, you will be advised of what action can be taken. Please bear in mind that your problem will likely be resolved at the dealership, using the dealer's facilities, equipment and personnel, so it is very important that your initial contacts be with the dealer.

Your purchase of a HONDA product is greatly appreciated by both your dealer and American Honda Motor Co., Inc. We want to assist you in every way possible to assure your satisfaction with your purchase.

Current customer service contact information:

United States, Puerto Rico, and U.S. Virgin Islands:

Honda Power Equipment dealership personnel are trained professionals. They should be able to answer any question you may have. If you encounter a problem that your dealer does not solve to your satisfaction, please discuss it with the dealership's management. The Service Manager or General Manager can help. Almost all problems are solved in this way.

If you are dissatisfied with the decision made by the dealership's management, contact the Honda Power Equipment Customer Relations Office. You can write:

American Honda Motor Co., Inc.
Power Equipment Division
Customer Relations Office
4900 Marconi Drive
Alpharetta, GA 30005-8847

Or telephone: (770) 497-6400 M-F, 8:30 am - 5:00 pm EST

When you write or call, please provide the following information:

- Model and serial numbers
- Name of the dealer who sold the Honda power equipment to you
- Name and address of the dealer who services your equipment
- Date of purchase
- Your name, address, and telephone number
- A detailed description of the problem

