

HONDA

Power

Equipment

Owner's Manual

LAWN TRACTOR

HT3810

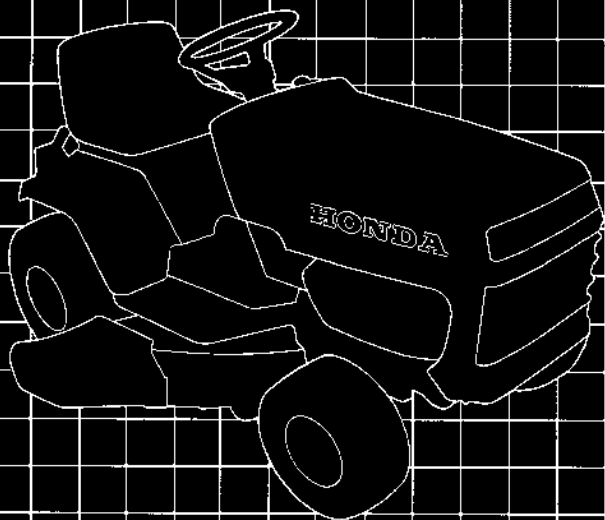

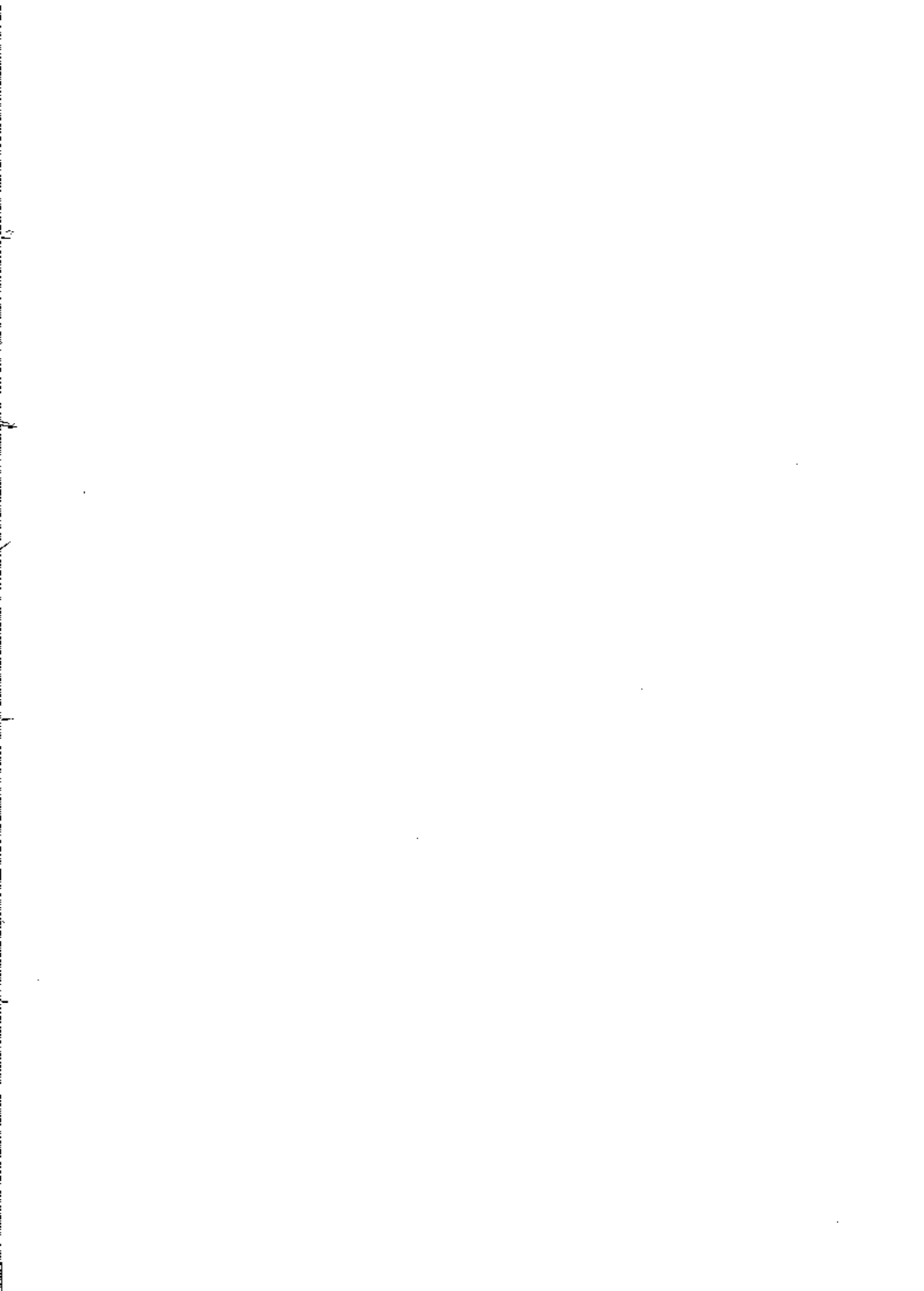

Thank you for purchasing a Honda Lawn Tractor.

This manual covers the operation and maintenance of the Honda HT3810 Lawn Tractor, type SA (side discharge).

All information in this publication is based on the latest product information available at the time of printing. Honda Motor Co., Ltd. reserves the right to make changes at any time without notice and without incurring any obligation.

No part of this publication may be reproduced without written permission.

This manual should be considered a permanent part of the lawn tractor and should remain with the lawn tractor when sold.

Pay special attention to statements preceded by the following words;

 **DANGER:** Indicates severe personal injury or death will result if instructions are not followed.

 **WARNING** Indicates a strong possibility of severe personal injury or death if instructions are not followed.

CAUTION: Indicates a possibility of personal injury or equipment damage if instructions are not followed.

NOTE: Gives helpful information.

If a problem should arise, or if you have any questions about the lawn tractor, consult an authorized Honda dealer. Honda lawn tractors are designed to give safe and dependable service if operated according to instructions.

 **WARNING** Operating a lawn tractor requires special effort to ensure the safety of the operator and the safety of others. Read and understand this Owner's Manual before operating the lawn tractor; failure to do so could result in personal injury or equipment damage.

It is illegal in some areas to operate a gasoline engine without a U.S.D.A. qualified spark arrester; check local laws and regulations. You can purchase an optional spark arrester for this lawn tractor from your authorized Honda power equipment dealer.

CONTENTS

1. SAFETY INSTRUCTIONS.....	3
2. COMPONENT IDENTIFICATION.....	8
3. CONTROLS.....	10
4. PRE-OPERATION CHECKS.....	15
5. OPERATION.....	25
• Starting the engine	
• Mowing	
• Stopping the engine	
• High altitude operation	
6. TRANSPORTING/STORAGE.....	34
7. MAINTENANCE.....	39
8. WIRING DIAGRAM.....	54
9. TROUBLE SHOOTING.....	55
10. SPECIFICATIONS.....	58
11. WARRANTY SERVICE.....	59

1. SAFETY INSTRUCTIONS

SAFETY LABEL LOCATIONS

Read all safety instructions before operating the lawn tractor.

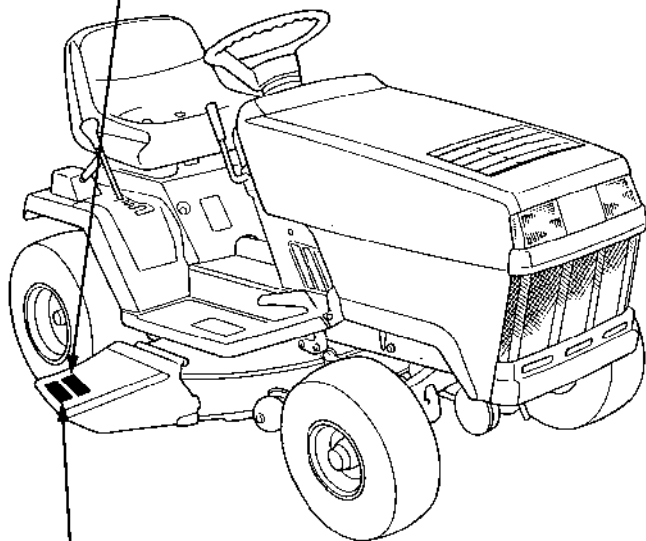

⚠ WARNING

- READ OWNER'S MANUAL BEFORE OPERATING.
- OPERATOR ONLY. DO NOT CARRY PASSENGERS.
- MAXIMUM SAFE OPERATING ANGLE 10 DEGREES. (17% GRADE)



10° MAX.

- REDUCE SPEED WHEN TURNING OR OPERATING ON SLOPES.
- STOP ENGINE BEFORE REMOVING GRASS CATCHER OR CLEANING DISCHARGE CHUTE.
- KEEP ALL SHIELDS AND SAFETY DEVICES IN PLACE.
- KEEP PEOPLE AND PETS AT A SAFE DISTANCE WHILE OPERATING.
- THIS LAWN TRACTOR IS NOT LEGAL FOR USE ON PUBLIC STREETS OR HIGHWAYS.

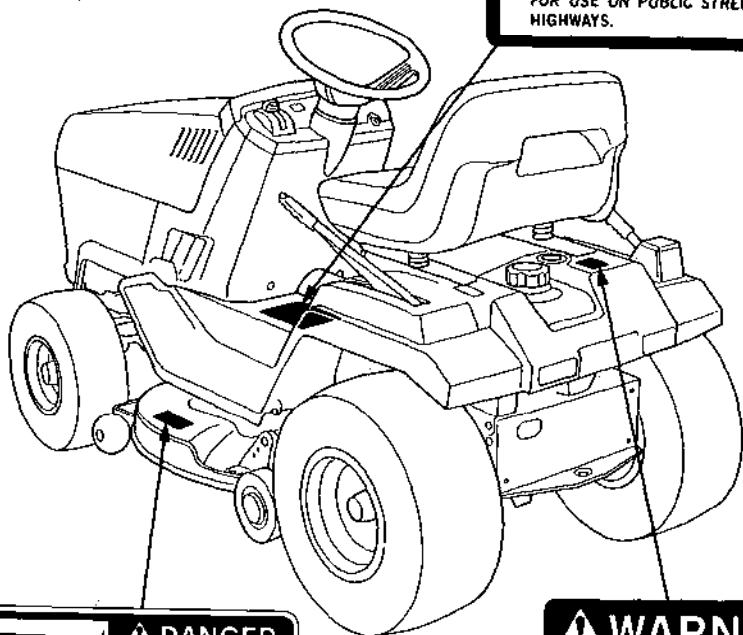

⚠ WARNING

**GASOLINE IS FLAMMABLE
STOP ENGINE, AVOID HEAT,
SPARKS, AND OPEN FLAME
WHEN REFUELING.**

LAWN TRACTOR SAFETY

 **WARNING** Operating a lawn tractor requires special efforts on your part to ensure your safety and the safety of others. Know these requirements before you operate the lawn tractor.

SAFE OPERATING RULES

- Always make a pre-operation inspection (page 15) before you start the engine. You may prevent an accident or equipment damage.
- All parts, especially guards and shields, should be in good condition, and securely fastened in place.
- Be sure all nuts, bolts and screws are tight, especially the blade mounting bolts.
- Do not remove any guards, warning labels, shields or safety devices; they are installed for your safety.
- Know how to stop the engine and blades quickly. Thoroughly understand operation of all controls.
- Never permit anyone to operate the lawn tractor without proper instructions.
- Do not allow passengers to ride on the tractor or any of its attachments.
- Children should not be permitted to operate this lawn tractor.
- To prevent serious injury, never put your hands or feet under the cutter deck.
- Do not operate the lawn tractor while barefoot. Wear sturdy shoes or boots and clothing that is not loose.
- Be alert. Do not operate the lawn tractor when you are tired, ill or under the influence of alcohol or drugs.
- Mow only in daylight or good artificial light.
- Watch out for and avoid rocks, roots, holes and other obstacles.
- If you hit an object, stop and inspect the lawn tractor; repair any damage before you operate the mower again.
- Replace damaged, worn or broken parts immediately.
- Do not operate near the edge of a ditch or an embankment.
- Engine exhaust contains poisonous carbon monoxide gas that may cause loss of consciousness and lead to death. Never run the engine in an enclosed area. Be sure to provide adequate ventilation.

BEFORE MOWING

- Before mowing, always clear the lawn of stones, sticks or other debris. These objects could be thrown out by the spinning blade and cause an injury or equipment damage.
- Select a safe operating speed (gear position) for the area to be mowed. 5th gear should be used only while driving to and from the storage area.
- Always ensure that the area in front of and behind the lawn tractor is clear of people, pets and debris before starting.
- Be very careful when you operate the lawn tractor in Reverse.
- Do not mow in Reverse unless it is absolutely necessary.
- Use extra care when pulling a trailer or when using optional attachments.
 - a. Be sure that any accessories (trailer hitch etc.) are securely mounted, and that they do not interfere with the safe operation of the tractor.
 - b. Reduce operating speeds when using attachments and limit loads to those you can safely control.
 - c. Use care when backing and avoid making sharp turns.

OPERATION ON SLOPES

- This lawn tractor is intended for use on relatively flat terrain. Do not use on sloped surfaces exceeding 10 degrees (17% grade). This angle may be further reduced by the condition and type of surface.

Maximum safe operating angle

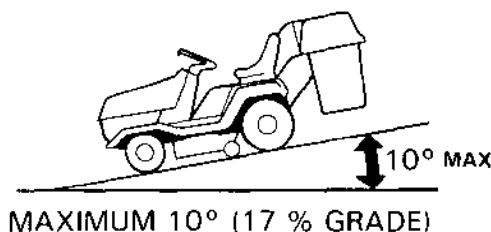

-
- If mowing on a sloping surface, always drive up and down the face of the grade. Never turn or drive across the face of the slope.
 - To prevent loss of control or overturning, always reduce speed and exercise extreme caution when operating on sloping or uneven surfaces.
 - Avoid turning or stopping on sloping surfaces; see page 30 for special instructions.
 - Do not back down or rapidly accelerate up a sloping surface; see page 30 for special instructions.
 - When mowing on slopes, empty the grass bags when they are half full. On a slope, the weight of full bags may cause the mower to tip over.

CLEANING AND STORAGE

- Leaves, grass clippings, oil and other combustible materials can become a fire hazard. Be sure to keep the engine compartment, the upper cutter deck surfaces and the belt and pulley areas clean.
- Stop the engine before removing the grass bags or cleaning the discharge chute.
- Check the condition of the grass catcher bags frequently. For your safety, replace any bag that is worn or deteriorated.
- Always empty the grass catcher bags when mowing is completed. Damp, decomposing grass clippings generate heat and can become a fire hazard.
- To reduce the possibility of fire, allow the engine and exhaust system to cool before storing the mower in an enclosed space or near combustible materials.

3. COMPONENT IDENTIFICATION

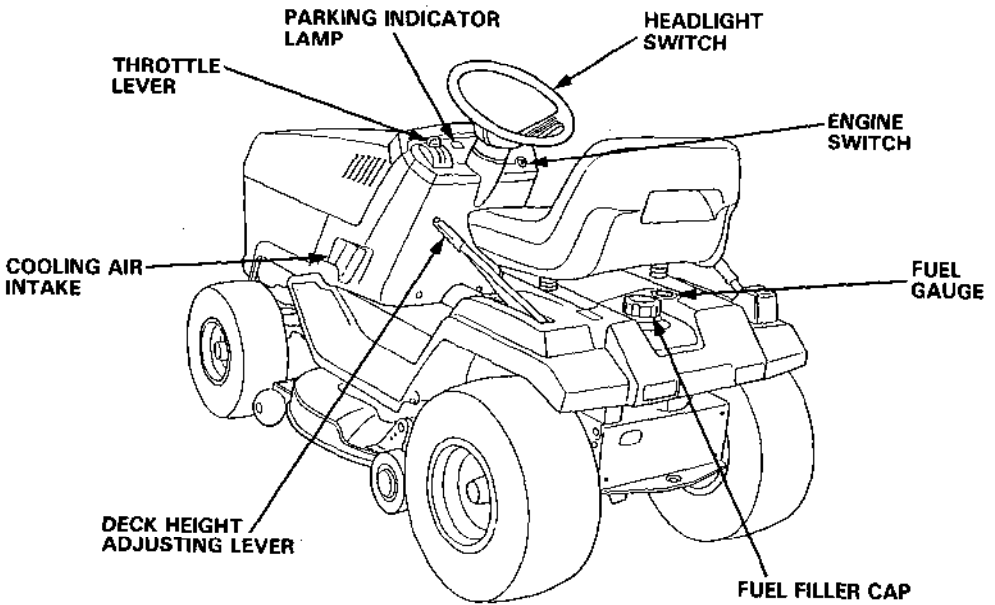
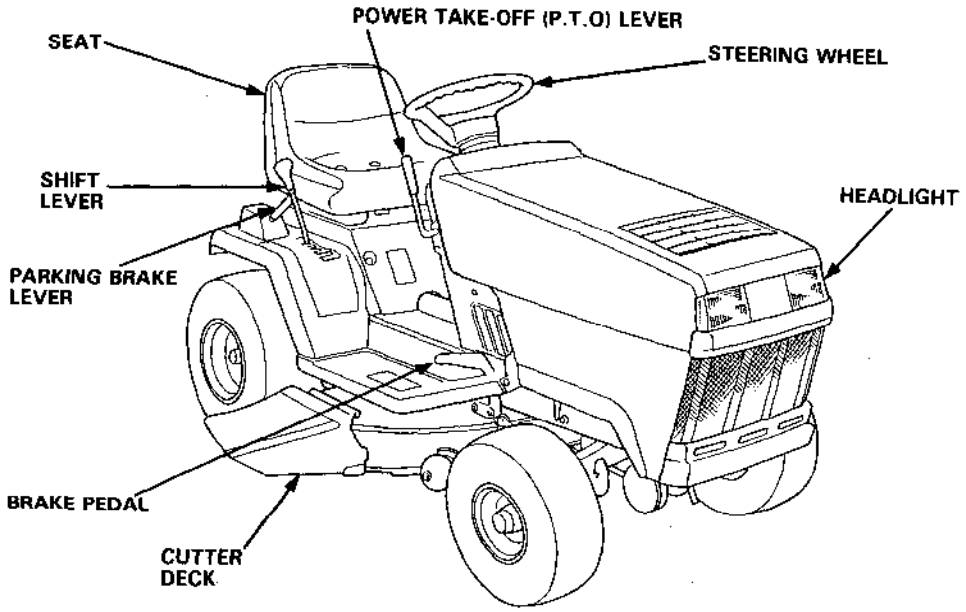

Engine compartment

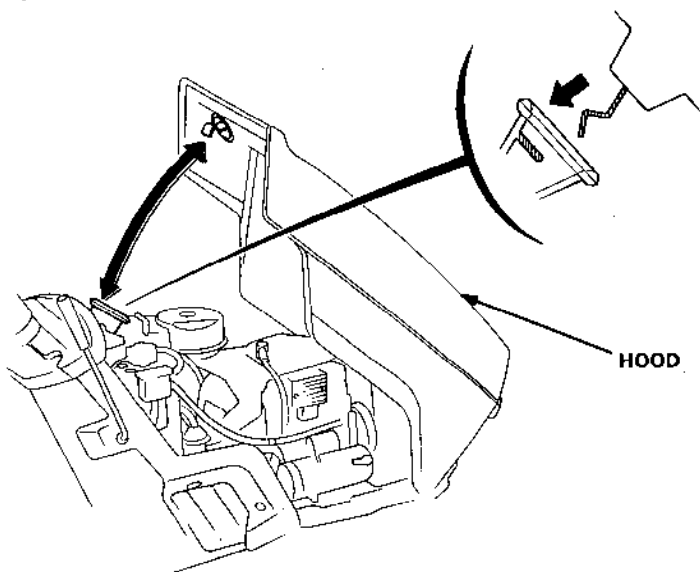

HOOD

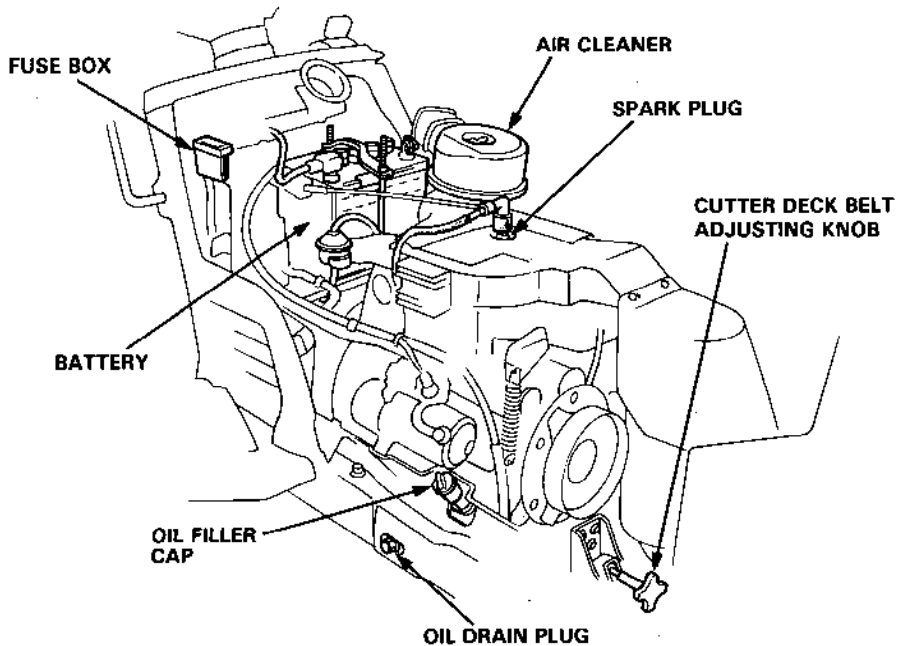

3. CONTROLS

1. Engine switch

WARNING

Always remove the key from the engine switch whenever the lawn tractor is unattended to prevent children or unauthorized persons from starting the engine.

This lawn tractor is equipped with an automotive type ignition switch, which controls all the electrical circuits. The switch is located on the right-hand side of the control panel.

Key positions: "START" to start the engine
"ON" to run the engine after starting
"OFF" to stop the engine.

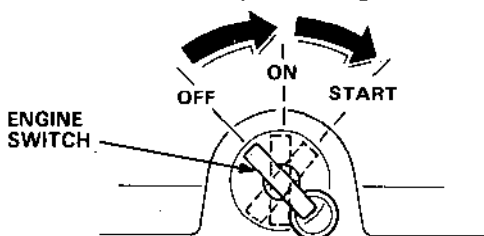

NOTE: The starter motor will not work unless the shift lever is in NEUTRAL and the P.T.O lever is in the OFF (Disengaged) position.

2. Throttle lever

The throttle lever controls engine speed from SLOW (idle) to FAST (max speed), and START (CHOKE) is for starting a cold engine.

NOTE: When the engine is warm or the air temperature is high, move the throttle to SLOW as soon as the engine starts.

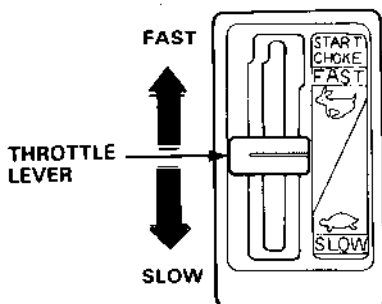

3. Cutter deck height adjusting lever

This lever is used to raise and lower the cutter deck. To adjust the cutting height, squeeze the handle lock and then press in and hold the set button. Raise or lower the lever until the desired cutting height appears on the indicator. At that point, release the set button and the handle lock. Be sure the handle lock returns to its normal position when released.

Cutting heights: 1.5, 2.0, 2.5, 3.0, 3.5, 4.0 in.

CAUTION:

- To avoid damage to the cutter deck, always raise it fully when driving the lawn tractor to and from the mowing area; this provides maximum ground clearance.
- To avoid damaging or disabling the handle locking mechanism, never attempt to screw the adjusting lever's set button in or out.

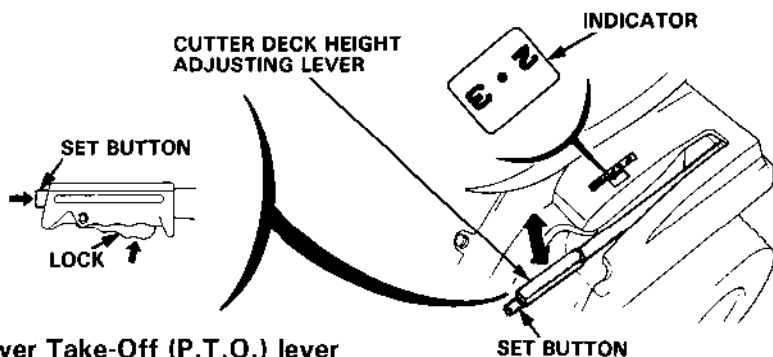

4. Power Take-Off (P.T.O.) lever

This lever engages and disengages the power take-off clutch to drive the blades.

Lever positions: ON (Engaged)Blades turn
OFF (Disengaged)Blades stop

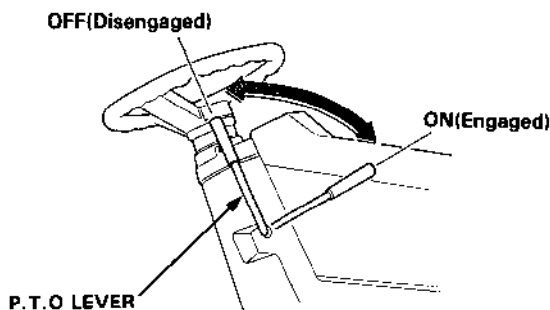

NOTE: An interlock switch prevents the engine from starting unless the P.T.O. lever is in the OFF position.

5. Shift lever

This lever is used to select one of the five forward speeds, neutral, or reverse. The drive clutch automatically disengages while the lever is being moved. The clutch will then engage automatically when put into gear unless the brake pedal is depressed.

CAUTION: Bring the tractor to a complete stop before shifting from a forward speed to reverse, or from reverse to a forward speed. Shifting between forward and reverse speeds while the tractor is moving can cause transmission damage.

When shifting from one forward speed range to another while moving, do not force the shift lever and do not shift up or down more than one slot at a time. Do not operate the shift lever on a slope.

NOTE: The tractor will pull away from a stop in any speed range. No shifting is necessary.

5th speed is not recommended for mowing but may be used for driving the tractor from one area to another.

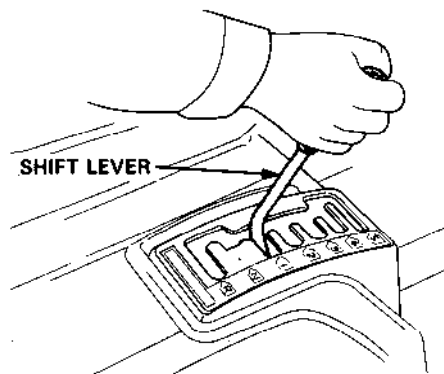

6. Headlight switch

The switch turns the headlights ON and OFF.

CAUTION:

- To avoid discharging the battery, run the engine with the throttle in the FAST position when using the headlights.
- Shift the transmission to a lower speed range to maintain a safe speed when visibility is poor.

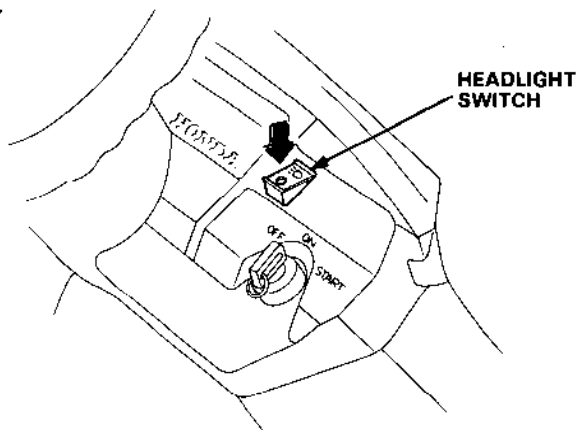

7. Brake pedal

Depressing the pedal will first disengage the tractor drive clutch. As you continue to depress the pedal, the brake will be applied to stop the tractor.

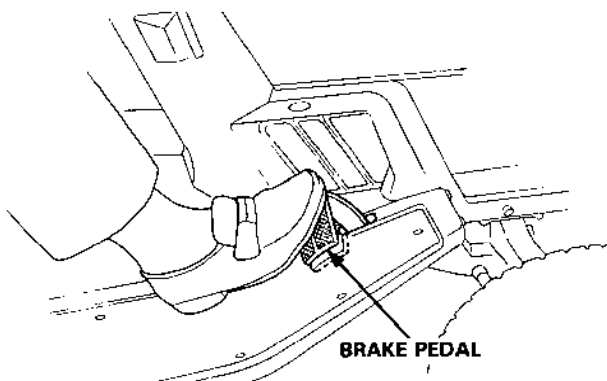

When the pedal is released, the clutch will engage automatically.

CAUTION: Releasing the brake pedal too slowly, or holding the pedal halfway out, can cause the clutch to slip, and may lead to premature clutch wear.

8. Parking brake lever

This lever is used to set the brake when the lawn tractor is parked. Pull the lever fully up until the ratchet locks, and be sure that the parking indicator lamp on the control panel is ON.

NOTE: The parking brake lever does not operate the automatic clutch. Always put the transmission in neutral, or turn off the engine switch before setting the parking brake. A warning buzzer will sound if the parking brake is engaged while the transmission is in gear and the engine switch is ON.

Pull the lever up slightly and press the lever button, lower the lever while holding the button in. The parking indicator lamp should go off.

WARNING Operating the lawn tractor with the parking brake set will result in severe damage to the brake lining, and could lead to a complete brake system failure.

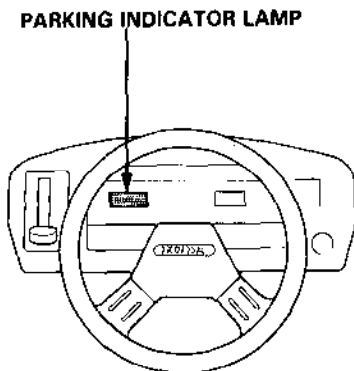
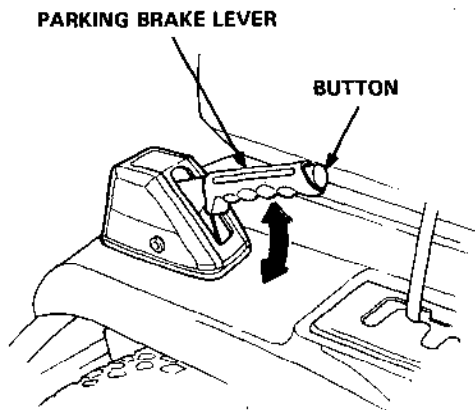

4. PRE-OPERATION CHECKS

For safe and efficient mowing, always make a pre-operation inspection before operating:

WARNING To prevent accidental start-up, remove the engine switch key, and disconnect the spark plug cap before performing the pre-operation inspection.

CAUTION:

- Inspect with the Lawn Tractor on level ground.
- Pull the parking brake fully up, set the shift lever in "N (Neutral)" and the P.T.O. lever in the "OFF" position before inspecting.

1. Check the air intake screen

Remove grass and dirt from both right and left side SCREENS to prevent the engine from overheating.

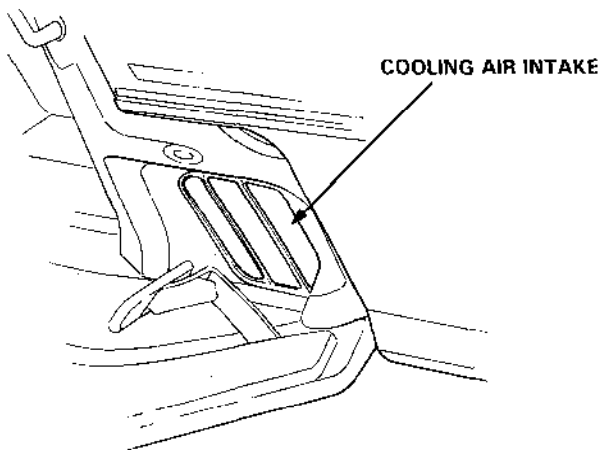

2. Check the engine oil level

CAUTION:

- Engine oil is a major factor affecting engine performance and service life. Non-detergent oil and 2-stroke engine oil are not recommended.
- Running the engine with insufficient oil can cause serious engine damage.

- Place the lawn tractor on a level surface.
- Open the engine hood, remove the oil filler cap and wipe the dipstick clean.
- Insert the dipstick into the oil filler neck, but do not screw it in.
- Check the oil level shown on the dipstick. If near or below the lower level mark, fill to the upper level mark with the recommended oil.

Use Honda 4-stroke oil, or an equivalent high detergent, premium quality motor oil certified to meet or exceed U.S. automobile manufacturers' requirements for service classification SE or SF (Motor oils classified SE or SF will show this designation on the container).

SAE 10W-40 is recommended for general, all-temperature use. Other viscosities shown in the chart may be used when the average temperature in your area is within the indicated range.

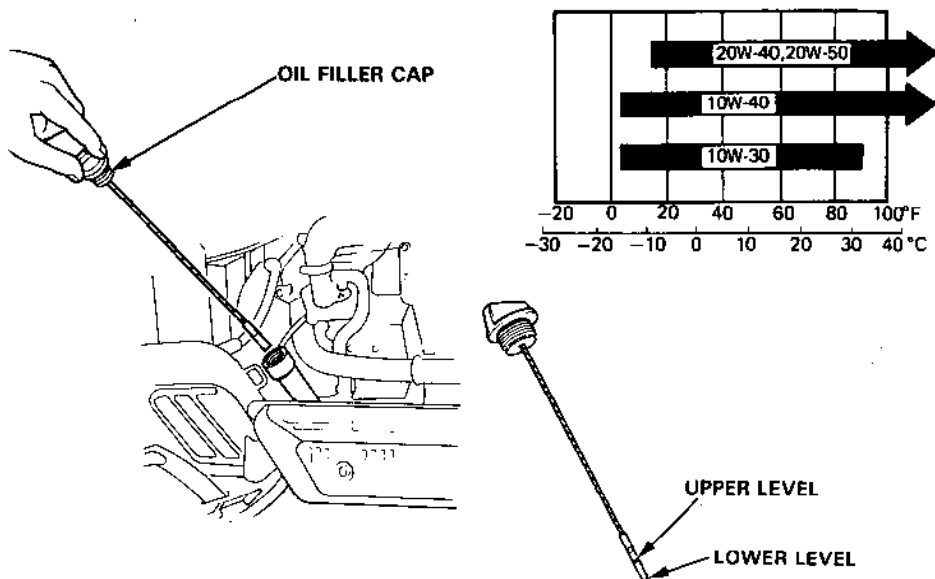

3. Check the fuel level

Raise the seat and check the fuel gauge.
Refill the tank if the fuel level is low.

Your engine is designed to use any gasoline that has a pump octane number $\left(\frac{R+M}{2}\right)$ of 86 or higher, or that has a research octane number of 91 or higher. Gasoline pumps at service station normally display the pump octane number.

We recommend that you use unleaded fuel because it produces fewer engine and spark plug deposits and extends the life of exhaust system components.

Never use stale or contaminated gasoline or an oil/gasoline mixture. Avoid getting dirt, dust or water in the fuel tank. Use of a lower octane gasoline can cause persistent "pinging" or heavy "spark knock" (a metallic rapping noise) which, if severe, can lead to engine damage.

CAUTION: If "spark knock" or "pinging" occurs at a steady engine speed under normal load, change brands of gasoline. If spark knock or pinging persists, consult your authorized Honda dealer. Failure to do so is considered misuse, and damage caused by misuse is not covered by Honda's Limited Warranty.

Occasionally you may experience light spark knock while operating under heavy loads. This is no cause for concern, it simply means your engine is operating efficiently.

After refueling, be sure to tighten the fuel tank cap firmly.

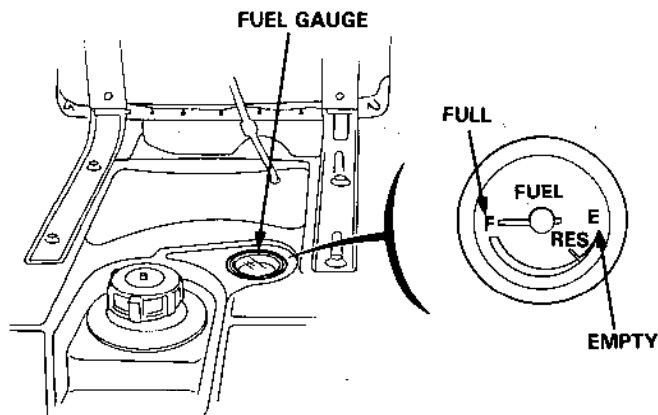

WARNING

- Gasoline is extremely flammable and is explosive under certain conditions.
- Refuel in a well-ventilated area with the engine stopped. Do not smoke or allow flames or sparks in the area where the engine is refueled or where gasoline is stored.
- Do not overfill the fuel tank (there should be no fuel in the filler neck). After refueling, make sure the tank cap is closed properly and securely.
- Be careful not to spill fuel when refueling. Spilled fuel or fuel vapor may ignite. If any fuel is spilled, make sure the area is dry before starting the engine.
- Avoid repeated or prolonged contact with skin or breathing of vapor.
KEEP OUT OF REACH OF CHILDREN.

GASOLINES CONTAINING ALCOHOL

If you decide to use a gasoline containing alcohol (gasohol), be sure it's octane rating is at least as high as that recommended by Honda. There are two types of "gasohol": one containing ethanol, and the other containing methanol. Do not use gasohol that contains more than 10% ethanol. Do not use gasoline containing methanol (methyl or wood alcohol) that does not also contain cosolvents and corrosion inhibitors for methanol. Never use gasoline containing more than 5% methanol, even if it has cosolvents and corrosion inhibitors.

NOTE:

- Fuel system damage or engine performance problems resulting from the use of fuels that contain alcohol is not covered under the warranty. Honda cannot endorse the use of fuels containing methanol since evidence of their suitability is as yet incomplete.
- Before buying fuel from an unfamiliar station, try to find out if the fuel contains alcohol, if it does, confirm the type and percentage of alcohol used. If you notice any undesirable operating symptoms while using a gasoline that contains alcohol, or one that you think contains alcohol, switch to a gasoline that you know does not contain alcohol.

4. Check the air cleaner elements

1. Remove the wing nut to remove the air cleaner cover.
2. Remove the air cleaner elements.

If the elements are dirty, follow the cleaning procedure described on page 42.

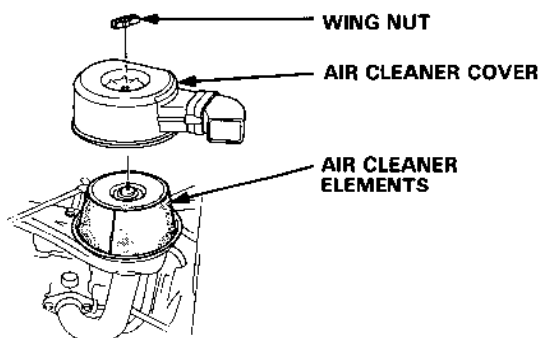

5. Check brake lining wear

Inspect brake lining condition every time the lawn tractor is used. Press firmly on the brake pedal with your hand and then check the position of the brake wear indicator. If the indicator is near the wear limit point, take the lawn tractor to an Authorized Honda Power Equipment Dealer for repair.

WARNING Under no circumstances should the lawn tractor be operated if the brake lining is at the service limit.

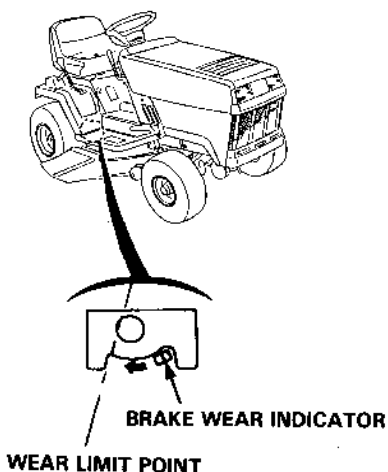
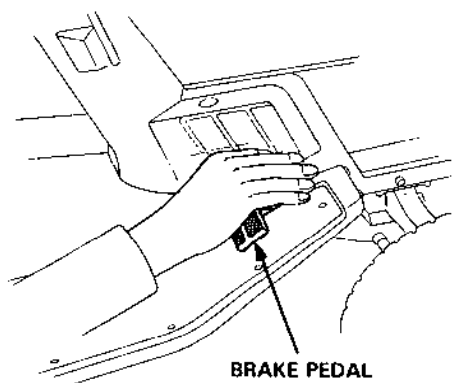

6. Check the cutter deck drive belt and blade belt.

1. Lower the cutter deck by using the cutter deck height adjusting lever, and open the engine hood.
2. Inspect the cutter deck drive belt and blade belt for wear or damage. If worn or damaged, replace the belts as described on page 48~50.

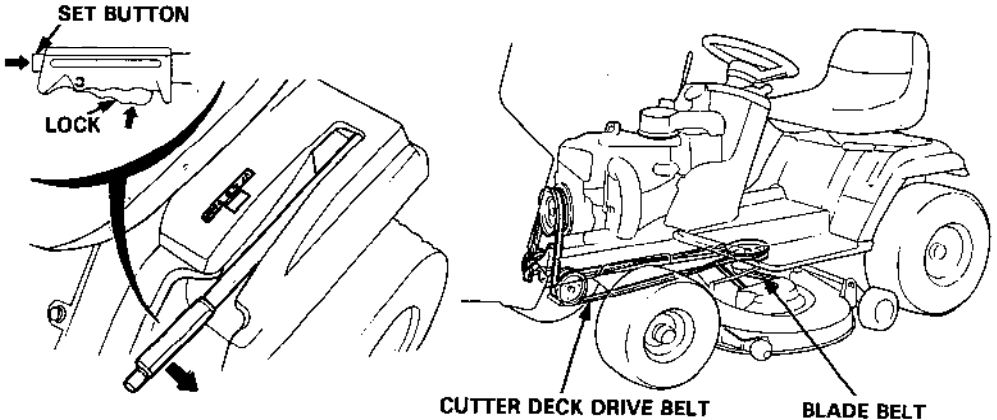

3. Check belt tension at the tensioner arm. The mark on the tensioner arm should align with the tension indicator. If not, turn the adjusting knob to align the mark with the indicator.

CAUTION: If the lawn tractor has been running, the muffler will be very hot. Allow it to cool before proceeding.

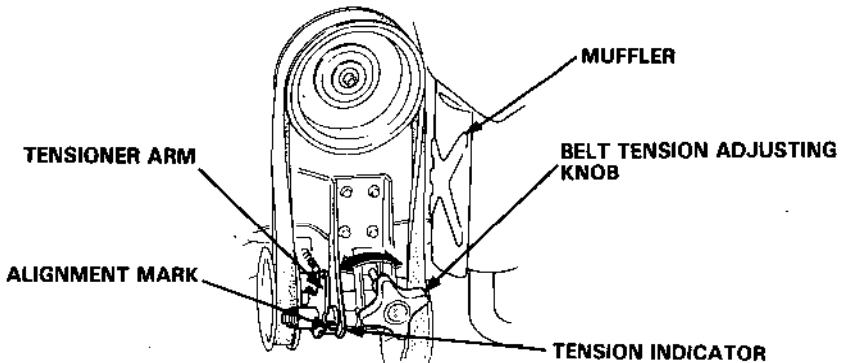

7. Check the battery

Open the engine hood and check the battery electrolyte level. The electrolyte level must be maintained between the upper and lower level lines on the side of the battery.

If the electrolyte level is low, remove the battery filler caps and carefully add distilled water to the upper level line.

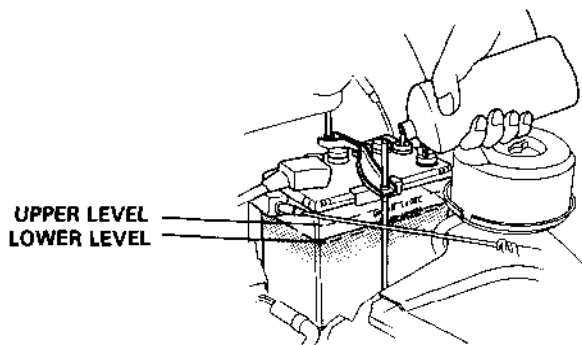

WARNING

- The battery gives off explosive gases; keep sparks, flames and cigarettes away. Provide adequate ventilation when charging or using batteries in an enclosed space.
- The battery contains sulfuric acid (electrolyte). Contact with skin or eyes may cause severe burns. Wear protective clothing and a face shield.
 - If electrolyte gets on your skin, flush with water.
 - If electrolyte gets in your eyes, flush with water for at least 15 minutes and call a physician immediately.
- Electrolyte is poisonous.
 - If swallowed, drink large quantities of water or milk and follow with milk of magnesia or vegetable oil and call a physician.
- **KEEP OUT OF REACH OF CHILDREN.**

CAUTION:

- Use only distilled water in the battery. Tap water will shorten the service life of the battery.
- Filling the battery above the **UPPER LEVEL** line may cause the electrolyte to overflow, resulting in corrosion to engine or nearby parts. Immediately wash off any spilled electrolyte.

8. Adjust the seat position

1. Loosen the seat mounting bolts.
2. Move the seat to a position that allows you to reach all controls easily and comfortably.
3. Tighten the seat mounting bolts securely.

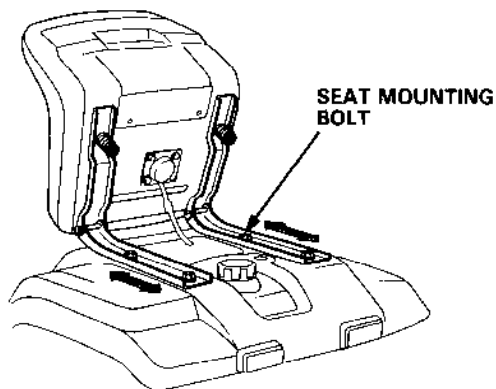

9. Check the tire pressure

CAUTION: Improper inflation may lead to premature tire failure. Never exceed the manufacturer's maximum tire pressure specification.

Check the tire pressure with an air pressure gauge.

Pressure: Front.... 0.9~1.1 kg/cm² (12.8~15.6 psi)

Rear 0.6~0.8 kg/cm² (8.5~11.4 psi)

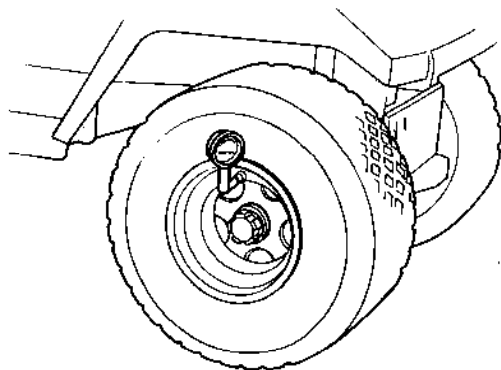

10. Blade condition

Before each use, check the cutter blades for damage or excessive wear.

WARNING To avoid severe personal injury, remove the ignition key and disconnect the spark plug cap to prevent accidental starting; wear heavy gloves to protect your hands from the cutter blades.

1. Move the P.T.O. lever to the OFF (disengaged) position, and raise the cutter deck height adjusting lever to the highest position.
2. Inspect both blades for cracks, bending, or wear. The right blade can be seen through the discharge opening on the right side of the cutter deck. The left blade can be seen under the left side of the cutter deck. Turn the blades 180° to inspect the opposite ends.

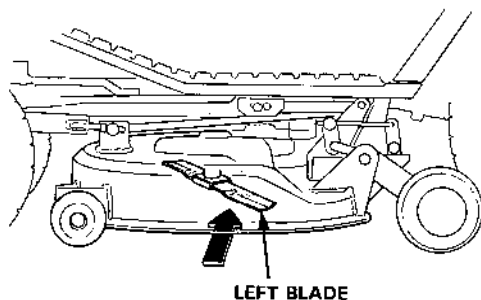
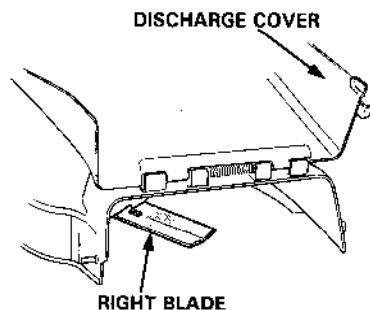

3. If either of the blades shows signs of damage or excessive wear, remove the cutter deck, and thoroughly inspect the blades (see cutter deck removal instructions on page 37). Dull blades can be sharpened, but blades that are worn out, bent, cracked, or otherwise damaged must be replaced. If the blades need sharpening or replacement, take the cutter deck to your authorized Honda lawn tractor dealer. Or, if you have the proper tools, you can remove and install the blades yourself (see blade removal and installation instructions on pages 51-52).

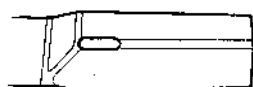

NORMAL

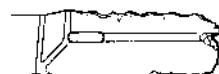

EXCESSIVELY
WORN



BENT

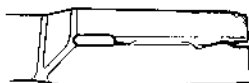

CRACKED

 **WARNING**

Severe personal injury can result if a piece of blade breaks off and is thrown from under the cutter deck.

- Never operate the lawn tractor with a worn or damaged blade.
- Never operate the lawn tractor with a blade that is cracked or notched at the base of its upturned rear edge.

CAUTION:

- Use a genuine Honda replacement blade, or equivalent.
- To reduce the possibility of weakening the blade, or causing imbalance or poor cutting performance, sharpening should be performed by an authorized Honda lawn tractor dealer.

5. OPERATION

Starting the engine

WARNING Exhaust contains poisonous carbon monoxide gas that may cause loss of consciousness and lead to death. Never run the engine in an enclosed area. Be sure to provide adequate ventilation.

1. Sit on the seat and check that the transmission is in neutral and the P.T.O lever is in the OFF (Disengaged) position.
2. Move the throttle lever to the START (CHOKE) position.

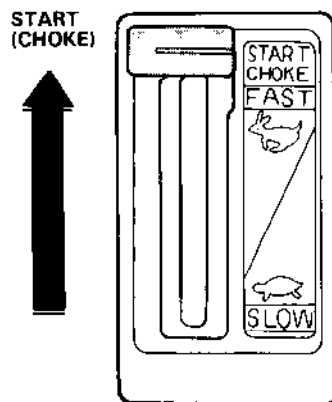

3. Turn the engine switch to START.

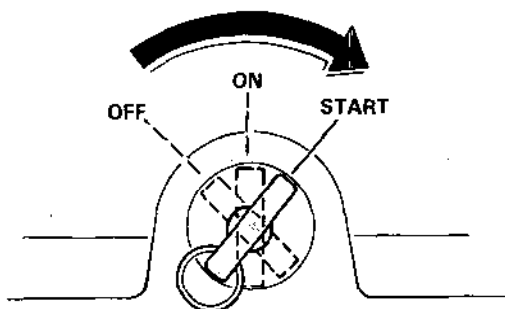

CAUTION: Do not use the starter motor for more than 5 seconds. If the engine fails to start, release the key, and wait at least 10 seconds before operating the starter motor again.

4. After the engine starts, let the engine switch return to ON.

5. After the engine warms up, move the throttle lever to the SLOW position.

NOTE: When the engine is warm or the air temperature is high, move the throttle to SLOW as soon as the engine starts.

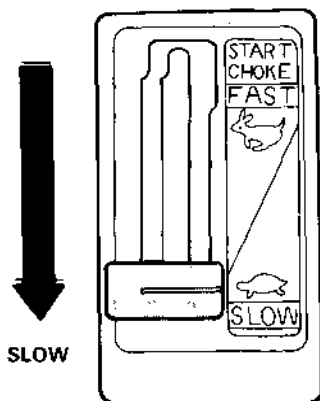

6. Seat safety switch operation check.

1. Move the P.T.O lever to ON (Engaged).
Rise off the seat — the engine should stop immediately.
2. Return the P.T.O lever to OFF (Disengaged) and restart the engine.
Release the parking brake and place the shift lever in the 1st speed range. While driving slowly, rise off the seat — the engine should stop immediately.



WARNING To prevent loss of control, perform this check on level ground, never on a slope.

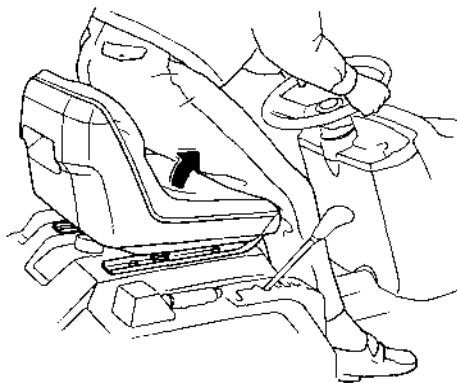

Mowing

WARNING Before operating this lawn tractor you should read and understand the **LAWN TRACTOR SAFETY** on pages 5–7.

CAUTION:

- In tall grass, first mow with the cutter deck fully raised (4.0 in); this will expose any hidden obstacles. When you are sure the area is completely cleared, re-mow at the desired height.
- If the lawn tractor accidentally gets caught by some object, hole or curb, do not try to ride over the obstruction or turn the steering to free the mower, the steering mechanism or cutter deck may be damaged.

NOTE: For best results, wait until the lawn is dry before mowing.

1. Set the cutter deck height adjusting lever to the desired cutting height.

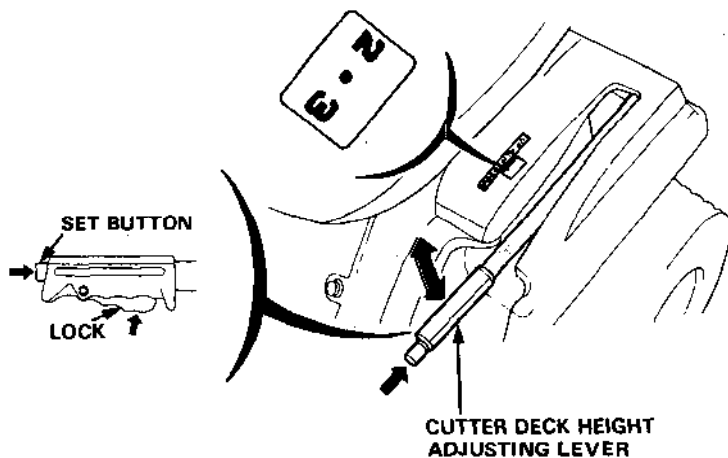

2. Move the throttle lever to the FAST position.

CAUTION: When mowing over rough ground or on hillsides, select the gear that will give a safe ground speed when the engine is operating at full throttle.

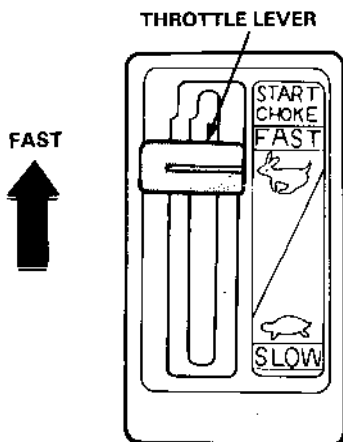

NOTE: You may operate the lawn tractor at intermediate throttle settings if desired, but always maintain sufficient engine speed for good pulling power and efficient blade operation. Use the shift lever to select the desired driving speed range.

3. Move the P.T.O. lever to the ON (Engaged) position.

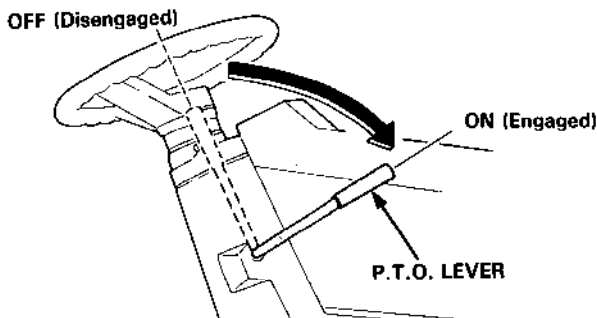

-
4. Move the shift lever to select the desired gear position. The clutch will engage automatically in about one second.

CAUTION: If clutch engagement occurs immediately or takes longer than one second, have the lawn tractor serviced by your HONDA dealer.

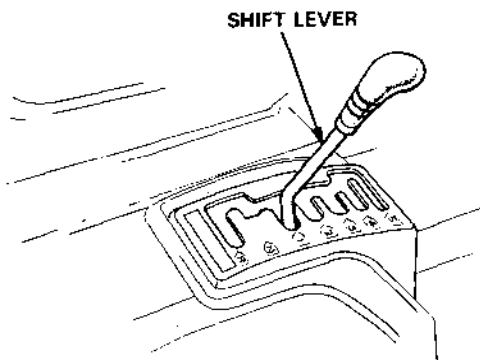

UPHILL STARTING PROCEDURE

If possible, avoid stopping the lawn tractor while driving uphill. If it is necessary to stop on a hill, follow the special procedure below when restarting:

 **WARNING**

- If this procedure is not followed when restarting on an uphill slope, the lawn tractor may roll backwards during clutch engagement, and this could cause it to tip over, resulting in severe personal injury.
- Abruptly applying either the brake pedal or the parking brake lever while the tractor is rolling backwards down a slope may cause the tractor to tip over.

- A. Set parking brake.
- B. Apply pressure to the brake pedal.
- C. Move the throttle lever to mid range.
- D. Shift the transmission to 1st gear position.
- E. Release the brake pedal.
- F. Wait until the clutch engages.
- G. Then release the parking brake lever.

 **WARNING**

If the parking brake lever is released before the brake pedal, the lawn tractor may roll downhill before the clutch engages. This may cause the lawn tractor to tip over.

5. Cutting Patterns

WARNING This cutting pattern is only recommended for a flat, level lawn surface. See safe operating rules page 5.

- To spread grass cuttings evenly, mow the outside perimeter of the lawn in a clockwise direction, and then mow the rest of the lawn counterclockwise.

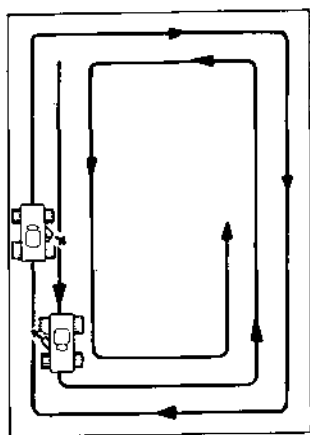

Stopping the Engine

- In an emergency;
Turn the engine switch OFF.
- In normal use;
(1) Move the P.T.O lever to OFF (Disengaged).

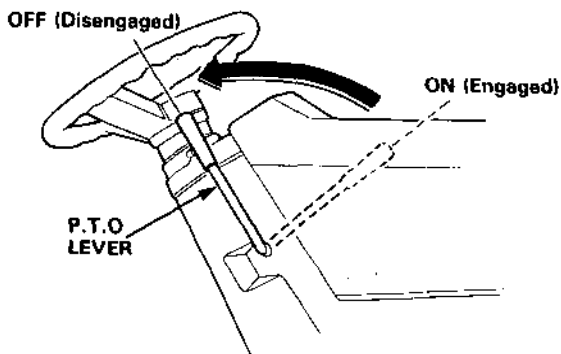

- (2) Move the shift lever to the Neutral position.
- (3) Set the parking brake.
- (4) Turn the engine switch OFF.

WARNING Always remove the key from the engine switch whenever the lawn tractor is unattended to prevent children or unauthorized persons from starting the engine.

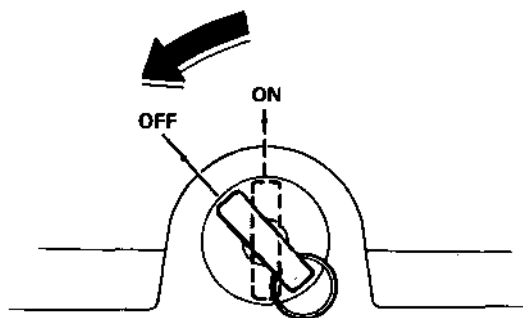

High altitude operation

At high altitude, the standard carburetor air-fuel mixture will be excessively rich. Performance will decrease, and fuel consumption will increase.

High altitude performance can be improved by installing a smaller diameter main fuel jet in the carburetor and readjusting the pilot screw. If you always operate the lawn tractor at altitudes higher than 6,000 feet above sea level, ask your authorized Honda lawn tractor dealer to perform these carburetor modifications.

Even with suitable carburetor jetting, engine horsepower will decrease approximately 3.5% for each 1,000 foot increase in altitude. The affect of altitude on horsepower will be greater than this if no carburetor modification is made.

CAUTION: Operation of the riding mower at an altitude lower than the carburetor is jetted for may result in reduced performance, overheating, and serious engine damage caused by an excessively lean air/fuel mixture.

6. TRANSPORTING/STORAGE

Transporting

Transport the lawn tractor on a flat, level, heavy duty trailer.

Turn the engine switch OFF and set the parking brake.

Tie the lawn tractor down securely, using the tie down points shown below.

CAUTION: To avoid damaging the tie-rods, be careful not to put the rope around or near them when securing the front end.

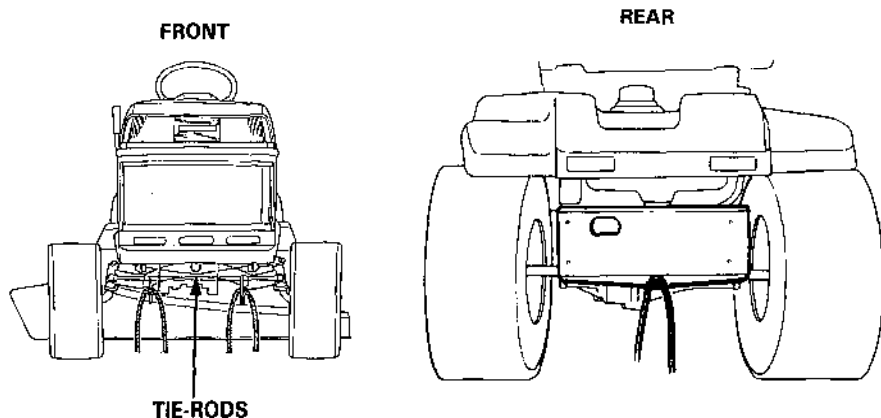

PROPER TIE-DOWN POINTS

WARNING Spilled fuel may ignite. To avoid fuel and oil spillage, keep the tractor level when transporting.

CAUTION: Do not pull the lawn tractor behind another vehicle, and do not use the lawn tractor to push another vehicle.

Preparation for storage.

The following steps should be taken to protect the tractor whenever it will be stored for longer than 30 days.

1. Siphon all gasoline from the fuel tank into a suitable gasoline container.

WARNING Do not drain the fuel tank when the exhaust system is hot.

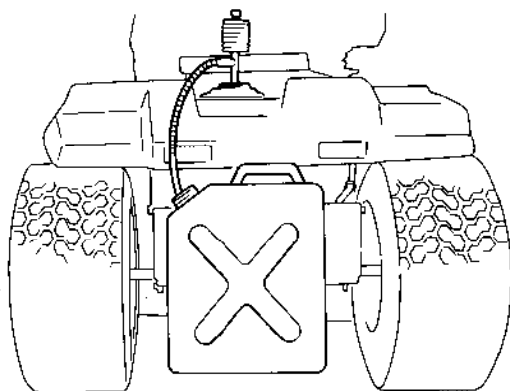

Disconnect the spark plug cap, and turn the engine switch to the ON position to activate the fuel pump.

Loosen the carburetor drain screw, and drain the fuel into a suitable gasoline container.

After draining, turn the engine switch OFF and tighten the drain screw securely.

WARNING Gasoline is extremely flammable and is explosive under certain conditions. Do not smoke or allow flames or sparks in the area.

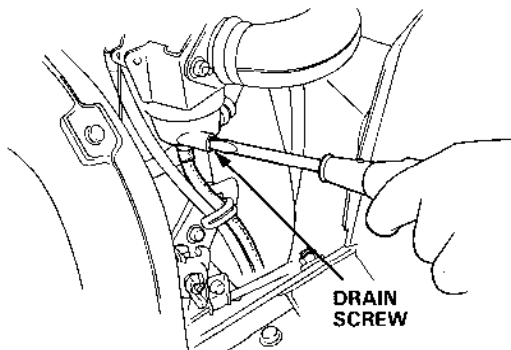

2. Change the engine oil (See p. 41)

NOTE: If the lawn tractor will be stored for longer than 3 months, remove the spark plugs and pour three tablespoons (approximately 1 oz.) of clean motor oil into each cylinder.

Place the PTO (Power Take-off) lever in the ON position. Turn the front clutch several rotations by hand, then return the PTO lever to the OFF position. Reinstall the spark plugs.

CAUTION: Be sure to wear heavy-duty gloves when turning the front clutch. If the lawn tractor has been running, the engine will be very hot. Allow it to cool before proceeding.

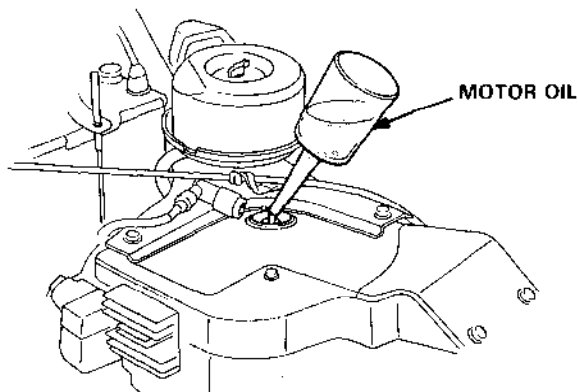

3. Remove the battery and store in a cool, dry place. Recharge it once a month.

4. Lower the cutter deck and loosen the belt tension adjusting knob (page, 20). Raise the pulley on the tensioner arm side, then remove the belt from the pulleys starting with the one on the opposite side. Remove the belt from the cutter deck driven pulley. Remove the six yellow colored lock pins (three on each side), and remove the cutter deck from the tractor.

CAUTION: When the cutter deck is removed, the return spring will cause the deck height adjusting lever to snap upward when the release button is pressed. Hold the lever firmly, and carefully return it to the UPPER position after removing the deck.

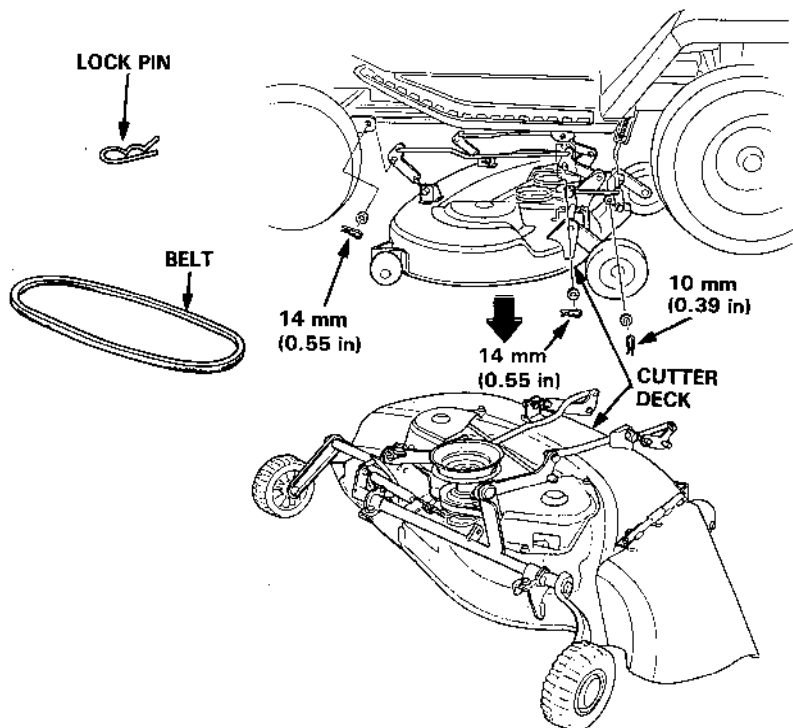

5. Turn the cutter deck upside down. Clean the underside of the deck with water, and dry thoroughly.
6. For longer service and greater efficiency, keep the underside of the mower housing clean and free of accumulated grass clippings by washing it down with a hose after use and/or cleaning it with a wire brush and scraper. Remove any rust and apply a rust-resistant paint. Cleaning and rust prevention are especially important before seasonal storage.

7. Reinstall the cutter deck.

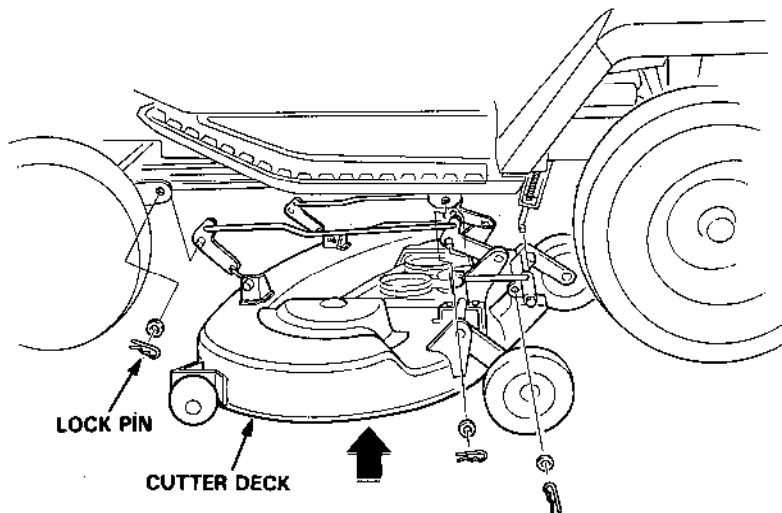

8. Store the tractor on a level surface in a dry, dust-free area with the parking brake lever set.

9. Cover the tractor to keep out dust.

Check tire air pressure regularly during storage and inflate if necessary.

Removal from storage

1. Check the battery electrolyte level (see p. 21). Fully recharge the battery, and install it in the tractor.
2. Remove the spark plug and check that it is clean and properly gapped (see p. 43).
Turn the engine a few revolutions by hand without the spark plug.
3. Thread the spark plug in as far as possible by hand, then tighten it 1/8 to 1/4 turn further with the plug wrench.
4. Check the engine oil level (see p. 16).
5. Fill the fuel tank, and start the engine by following the starting instructions (see p. 25).

NOTE: If the cylinder was coated with oil, the engine will smoke at start-up; this is normal.

7. MAINTENANCE

WARNING

- Shut off the engine and set the parking brake before performing any maintenance.
- To prevent accidental start-up, remove the engine switch key and disconnect the spark plug caps.
- The lawn tractor should be serviced by an authorized HONDA dealer unless the owner has proper tools and service data and feels he is mechanically qualified.

CAUTION: Use only genuine Honda parts or their equivalent for maintenance or repair. Replacement parts which are not of equivalent quality may damage the tractor.

Periodic inspection and adjustment of the Honda HT3810 is essential if high level performance is to be maintained. Regular maintenance will also ensure a long service life. The required service intervals and the kind of maintenance to be performed are described on the following page.

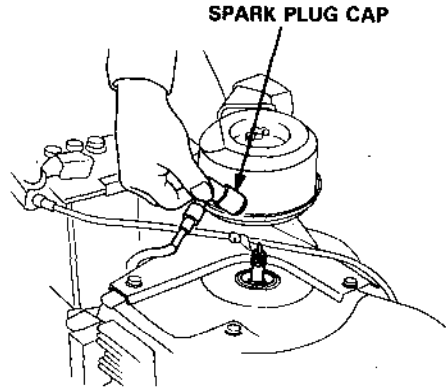
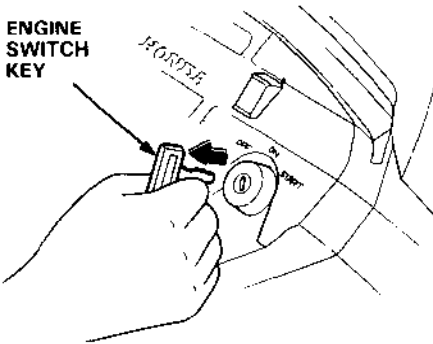

MAINTENANCE SCHEDULE

ITEM	REGULAR SERVICE PERIOD Perform at every indicated month or operating hour interval, whichever comes first.	EACH USE	FIRST	EVERY	EVERY	EVERY
			3 MONTHS OR 20 HRS (3)	6 MONTHS OR 50 HRS (3)	YEAR OR 100 HRS (3)	3 YEARS OR 300 HRS (3)
Engine oil	Check level	○				
	Change		○		○	
Air cleaner	Check	○				
	Clean			○ (1)		
Seat switch operation	Check	○			○ (2)	
Cooling air intake	Clean	○				
Parking brake indicator lamp and buzzer operation	Check	○		○ (2)		
Battery electrolyte	Check level	○				
	Check level and gravity			○ (2)		
Tire pressure	Check	○				
Deck belt and blade belt	Check	○				
Grass bag (optional part)	Clean	○				
Foot brake	Check	○				
Blade bolt tightness	Check		○ (2)	○ (2)		
Blade condition	Check	○				
Shift lever	Check		○ (2)	○ (2)		
	Adjust			○ (2)		
Brake and clutch (fastener tightness)	Check		○ (2)		○ (2)	
Parking brake	Check			○ (2)		
Spark plug	Check-Clean				○	
Spark arrester (optional part)	Clean				○	
Drive clutch	Check				○ (2)	
Transmission oil	Check level				○ (2)	
Fuel tank	Clean				○ (2)	
Fuel filter	Check (Replace if necessary)				○ (2)	
P.T.O. cable	Check-Adjust		○ (2)		○ (2)	
P.T.O. clutch	Check				○ (2)	
Throttle cable	Check-Adjust				○ (2)	
Front axle	Grease				○ (2)	
Fuel line	Check (Replace if necessary)					○ (2)
Valve clearance	Check-Adjust					○ (2)
Combustion chamber and valves	Clean-Lap					○ (2)
Engine fins and shroud	Clean					○ (2)

NOTE: (1) Service the air cleaner more frequently when used in dusty areas.

(2) These items should be serviced by an authorized Honda lawn tractor dealer, unless the owner has proper tools and is mechanically proficient. See the Honda Shop Manual.

(3) For professional commercial use, log hours of operation to determine proper maintenance intervals.

1. Engine oil change

NOTE: Drain the oil while the engine is still warm to assure rapid and complete draining.

1. Open the engine hood.
2. Remove the oil filler cap and drain plug, and drain the oil into a suitable container.
3. Retighten the drain plug securely.
4. Refill to the upper level mark on the dipstick with the recommended oil (see p. 14). Tighten the oil filler cap securely.

OIL CAPACITY: 1.2ℓ (1.27 US qt)

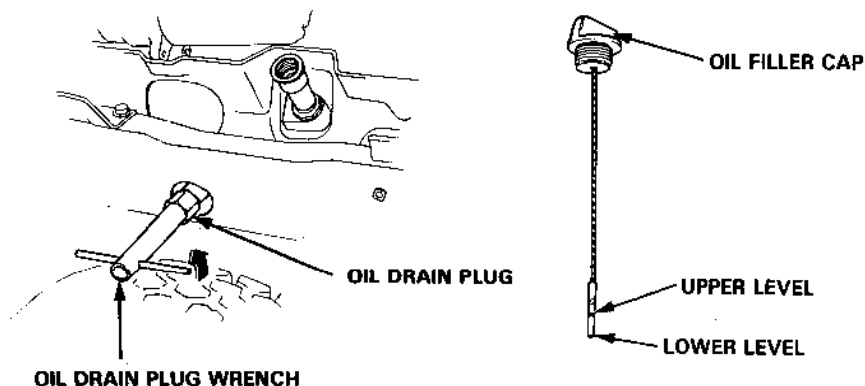

CAUTION: Used motor oil may cause skin cancer if repeatedly left in contact with the skin for prolonged periods. Although this is unlikely unless you handle used oil on a daily basis, it is still advisable to thoroughly wash your hands with soap and water as soon as possible after handling used oil.

NOTE: Please dispose of used motor oil in a manner that is compatible with the environment. We suggest you take it in a sealed container to your local service station for reclamation. Do not throw it in the trash or pour it on the ground.

2. Air cleaner service

A dirty air cleaner will restrict air flow to the carburetor. To prevent carburetor malfunction, service the air cleaner regularly. Service more frequently when operating the tractor in extremely dusty areas.

WARNING Never use gasoline or low flash point solvents for cleaning the air cleaner element. A fire or explosion could result.

CAUTION: Never run the engine without the air cleaner. Rapid engine wear will result.

1. Open the engine hood.
2. Remove the wing nut and the air cleaner cover. Remove the elements and separate them. Carefully check both elements for holes or tears and replace if damaged.
3. Foam element: Clean in warm soapy water, rinse and allow to dry thoroughly. Or clean in high flash-point solvent and allow to dry. Dip the element in clean engine oil and squeeze out all the excess. The engine will smoke during initial start-up if too much oil is left in the foam.
4. Paper element: Tap the element lightly several times on a hard surface to remove excess dirt, or blow compressed air through the filter from the inside out. Never try to brush the dirt off; brushing will force dirt into the fibers.

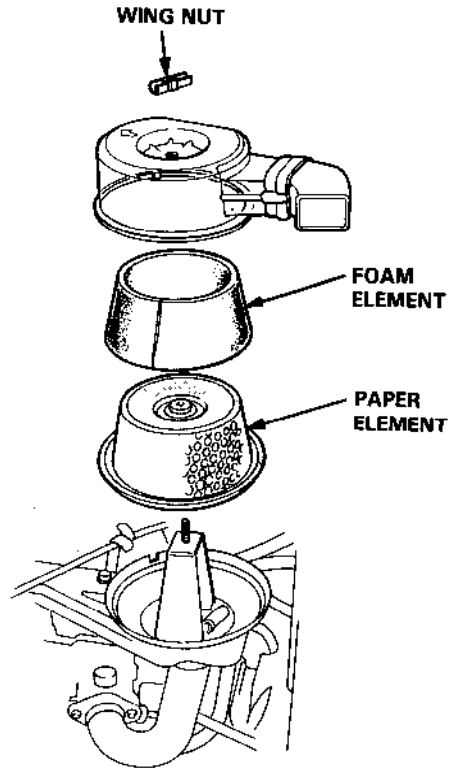

3. Spark plug service.

Recommended spark plug: BR4HS (NGK)

To ensure proper engine operation, the spark plug must be properly gapped and free of deposits.

1. Open the engine hood and remove the spark plug cap.
2. Clean any dirt from around the spark plug base.
3. Use a spark plug wrench to remove the spark plug.

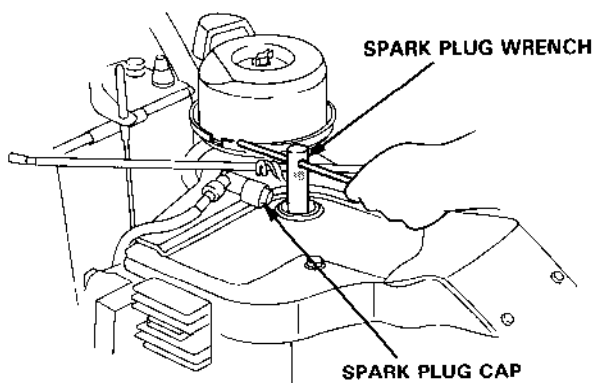

4. Visually inspect the spark plug. Discard it if the insulator is cracked or chipped. Clean the spark plug with a wire brush if it is to be reused.
5. Measure the plug gap with a feeler gauge.
The gap should be 0.6~0.7 mm (0.024~0.028 in). Correct as necessary by carefully bending the side electrode.

0.6~0.7 mm
(0.024~0.028 in)

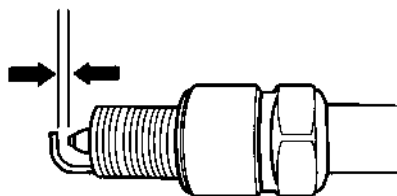

6. Thread the plug in by hand to prevent cross threading.

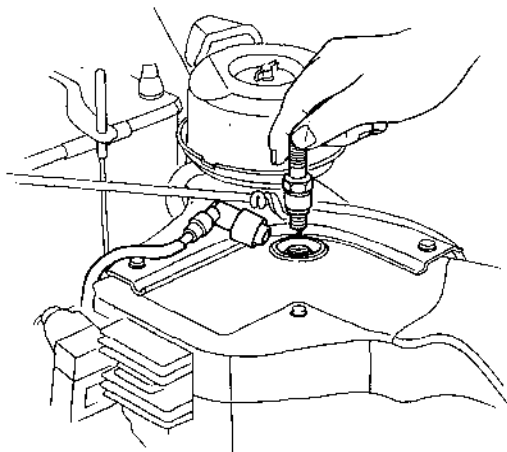

7. After a new spark plug has been seated by hand, it should be tightened 1/2 turn with a wrench to compress its washer.

If a used plug is being reinstalled, it should only require 1/8 to 1/4 turn after being seated.

CAUTION:

- The spark plug must be securely tightened. An improperly tightened plug can become very hot and possibly damage the engine.
- Never use a spark plug with an improper heat range.

4. Battery electrolyte level check

Open the engine hood and check the electrolyte level in each battery cell. Fill the battery with distilled water to the upper level line. Never overfill the battery. Any corrosion around the positive and negative terminals should be washed off with a solution of baking soda and warm water. Dry the terminals and retighten the terminal bolts if necessary, then coat the terminals with grease.

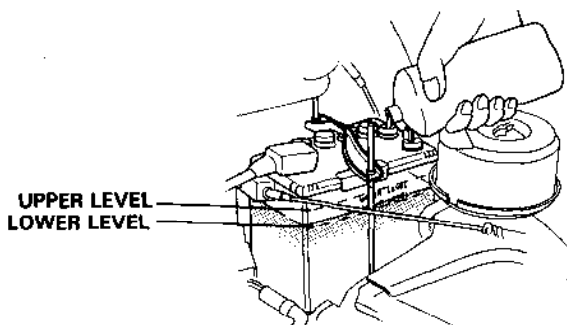

WARNING

- The battery gives off explosive gases; keep sparks, flames and cigarettes away. Provide adequate ventilation when charging or using batteries in an enclosed space.
- The battery contains sulfuric acid (electrolyte). Contact with skin or eyes may cause severe burns. Wear protective clothing and a face shield.
 - If electrolyte gets on your skin, flush with water.
 - If electrolyte gets in your eyes, flush with water for at least 15 minutes and call a physician immediately.
- Electrolyte is poisonous.
 - If swallowed, drink large quantities of water or milk and follow with milk of magnesia or vegetable oil and call a physician.
- **KEEP OUT OF REACH OF CHILDREN.**

CAUTION:

- Use only distilled water in the battery. Tap water will shorten the service life of the battery.
- Filling the battery above the **UPPER LEVEL** line may cause the electrolyte to overflow, resulting in corrosion to engine or nearby parts. Immediately wash off any spilled electrolyte.

5. Fuel filter

Remove the fuel filter by pulling it out of its clip under the fuel tank and visually inspect it through the opening in the hitch plate. Replace the filter if it is contaminated with dirt or water.

WARNING

- Gasoline is extremely flammable and is explosive under certain conditions. Do not smoke or allow flames or sparks in the area.
- After installing the filter, check for leaks, and make sure the area is dry before starting the engine.

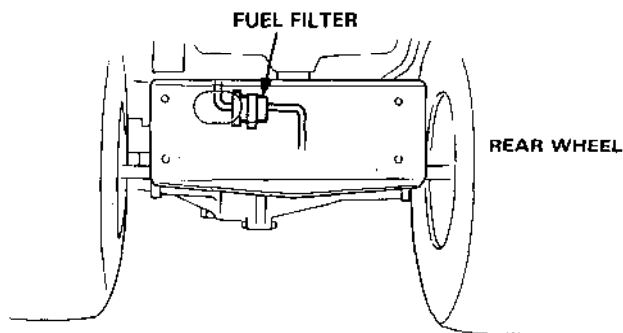

6. Headlight bulb replacement

Push and twist the bulb connector counterclockwise, then remove the connector and bulb.

When installing the bulb, align the projection on the base of the bulb with the groove in the headlight case.

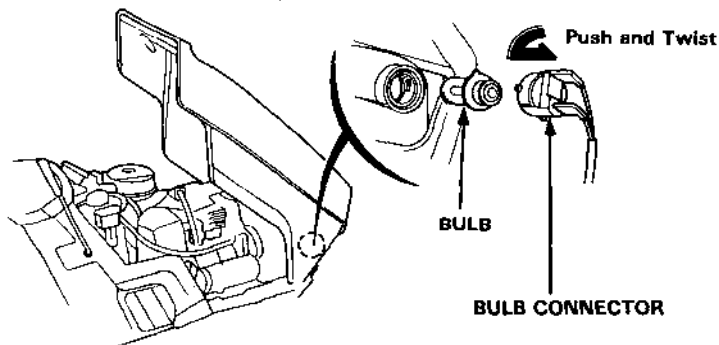

7. Wheel removal

WARNING

- Do not attempt to remove a wheel unless the lawn tractor is on firm and level ground.
- Do not attempt to remove or replace a tire unless you have the equipment and knowledge to do so properly.

Block wheels securely.

1. Remove the center cap and cotter pin.
2. Remove the wheel hub nut with a 19 mm socket.
3. Raise the wheel using a jack at the nearest jack point and remove the wheel.
4. Install the wheel in the reverse order of removal. Be sure to use a new cotter pin and bend it properly as shown.

[Jack points]

Front

Rear

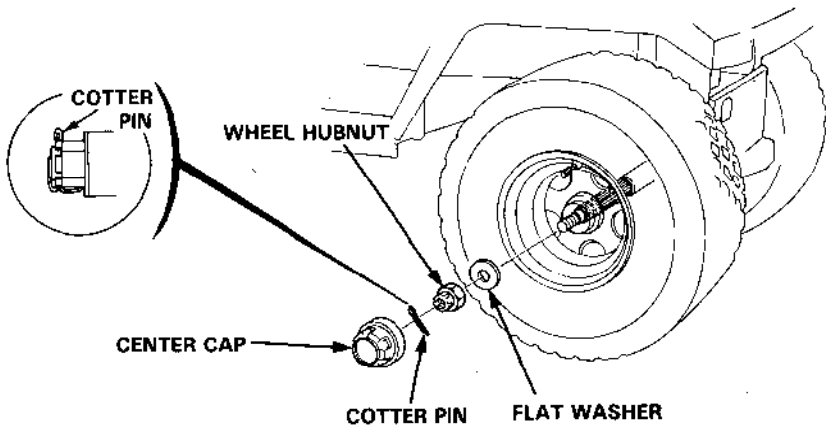
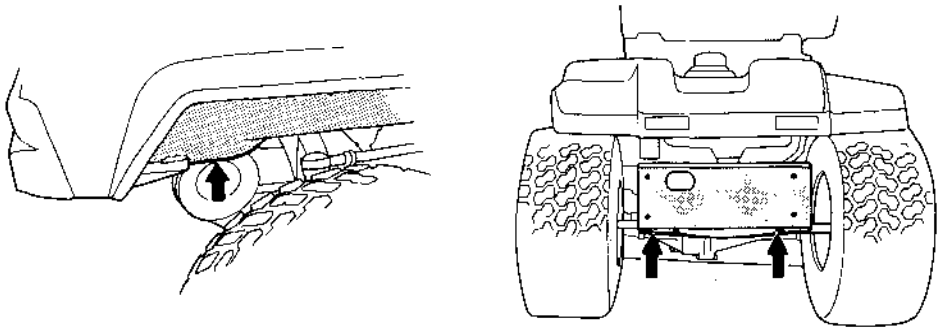

8. Cutter deck drive belt replacement

WARNING Never attempt to change drive belts while the engine is running. Remove the engine key from the ignition and disconnect the spark plug cap to prevent accidental start up.

CAUTION:

- Wear heavy gloves to protect your hands when replacing drive belts or when working with cutter blades.
- If the tractor has been running, the engine, muffler and radiator will be very hot. Allow them to cool before proceeding.

1. Lower the cutter deck.
2. Loosen the belt tension adjusting knob. Remove the belt stopper B located near the tensioner pulley and raise the pulley on the tensioner arm side. Remove the belt from the pulleys starting with the one on the opposite side.
3. Remove the belt from the cutter deck driven pulley.
4. Open the engine hood, and remove the belt stopper A by removing the two 6 mm bolts.
5. Remove the belt from the engine pulley.
6. Installation sequence is essentially the reverse order of removal. See Page 20 for belt tension adjustment.

CAUTION:

- When reinstalling the belt stopper, check that the clearance between the belt stopper and pulley is 3–6 mm (0.1–0.2 in.), then tighten the 6 mm bolts securely.
- After installing the belt and adjusting the belt tension (see page 20), start the engine and shift the P.T.O. lever into ON and OFF to be sure that it operates properly.

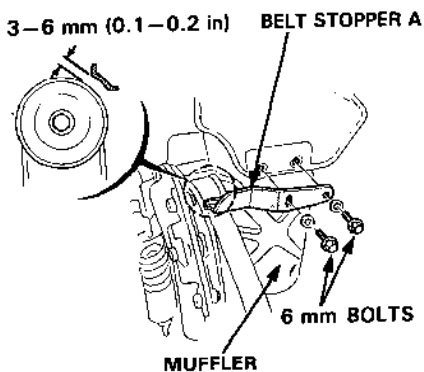
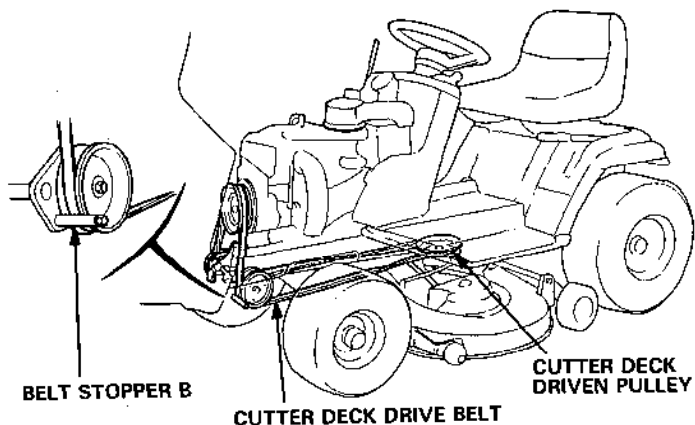

9. Blade belt replacement

1. Lower the cutter deck, remove the six yellow colored lock pins (see p. 37) and remove the cutter deck.
2. Remove the bolt and nuts and then remove the pulley covers.
3. Pull the belt off pulley A, hold the belt securely and slowly release the idle pulley.

CAUTION: If the belt is not released slowly, the idle pulley will move suddenly and could injure your hand.

4. Remove the belt from the other pulleys, and replace the belt.

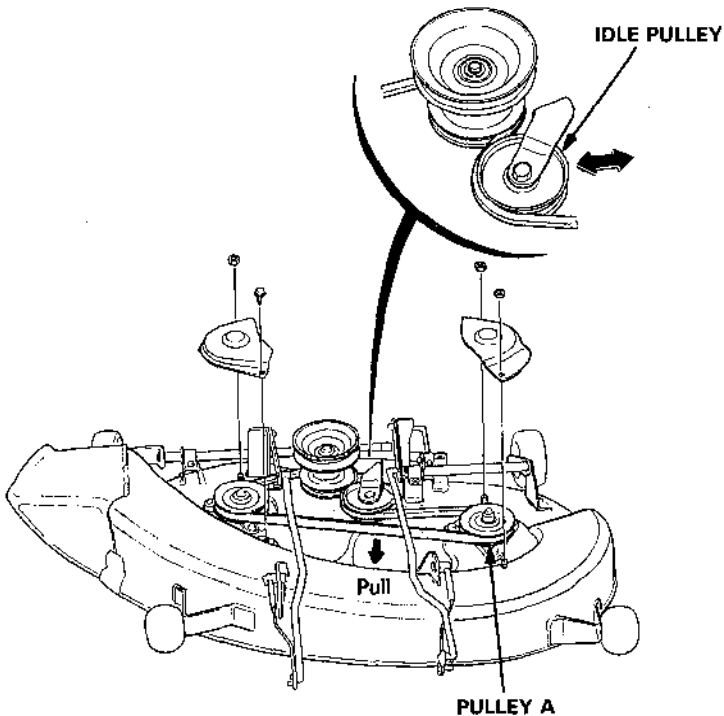

10. Blade bolt tightness/Blade replacement

WARNING To avoid severe personal injury, remove the ignition key and disconnect the spark plug cap to prevent accidental starting; wear heavy gloves to protect your hands from the cutter blade.

■ Blade bolt tightness

- 1. Remove the cutter deck from the tractor (see page 38).
- 2. Turn the cutter deck upside down.
- 3. Clean dirt and grass from the blade and the inside of the cutter deck.
- 4. Hold the blade firmly, and use a torque wrench to check that the blade bolt is properly tightened.

Blade bolt torque: 4.5–5.5 kg-m (32.6–39.8 ft-lb)

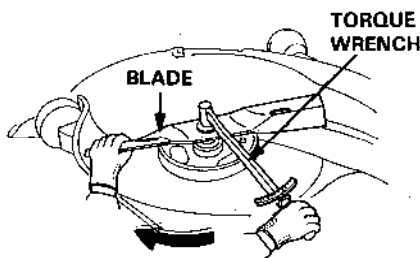

■ Blade removal

- 1. Hold the blade firmly, and remove the blade bolt and the washer.
- 2. Remove the blade and blade holder.

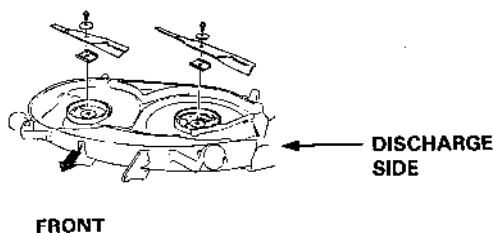

■ Blade installation

CAUTION: Use a genuine Honda replacement blade or equivalent.

- 1. Clean dirt and grass from the blade, blade holder, and the inside of the cutter deck.
- 2. Install the blade holder, blade, washer and blade bolt.

NOTE: Right and left blades are not interchangeable. Be sure to install the high-lift blade on the right (discharge side) and the low-lift blade on the left sides, as shown.

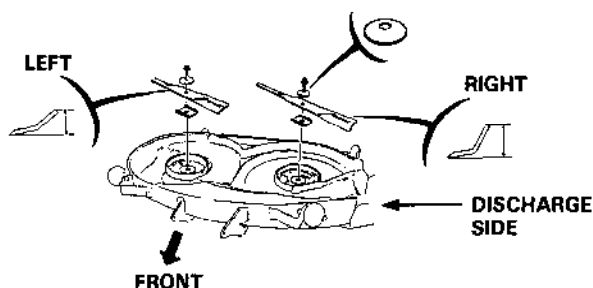

CAUTION: Be sure the blade is properly aligned with the blade holder before tightening the blade bolt. Do not allow the blade to overlap the edge of the holder.

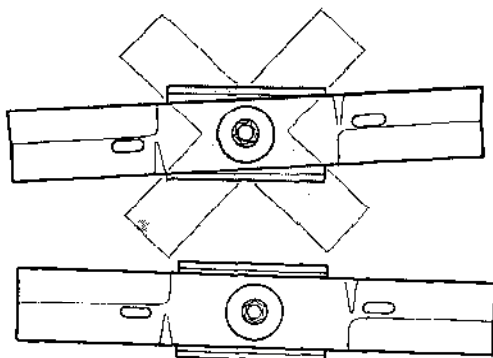

- Install the washer with the side marked "INSIDE" facing the blade.
 - The blade bolt and washer are specially designed for this application and must not be replaced with any other bolt or washer.
- 3. Hold the blade firmly, and tighten the blade bolt to a torque value of 4.5–5.5 kg-m (32.55–39.78 ft-lb).

13. Spark arrester maintenance (optional part)

WARNING The muffler becomes very hot during operation and remains hot for a while after stopping the engine. Be careful not to touch the muffler while it is hot. Allow it to cool before proceeding.

CAUTION: The spark arrester must be serviced every 100 hours to maintain its efficiency.

1. Remove the two 5 mm screws from the exhaust pipe tip. Remove the exhaust pipe tip and spark arrester.

CAUTION: Be careful not to damage the spark arrester screen.

2. Use a wire brush to remove carbon deposits from the spark arrester screen.

NOTE: Inspect the spark arrester screen for holes or tears. Replace if necessary.

3. Reinstall the spark arrester and exhaust pipe tip.

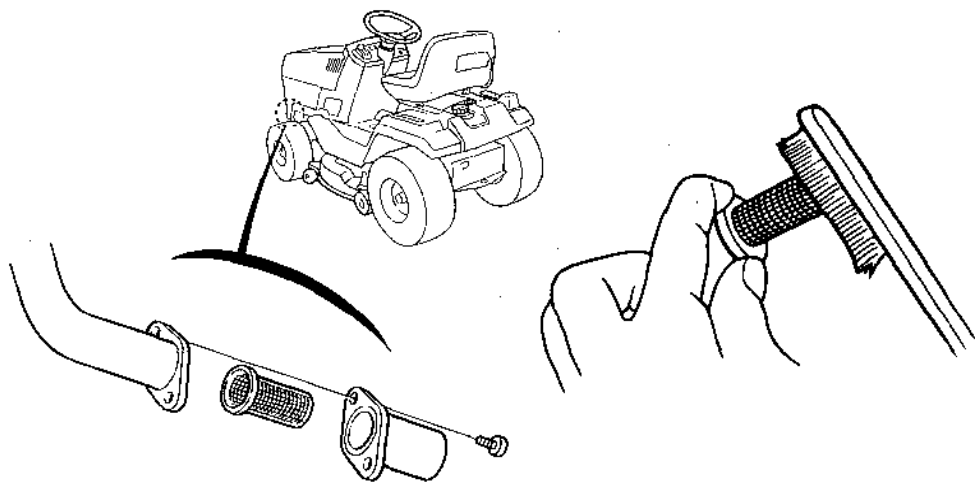

8. WIRING DIAGRAM

W	BLACK
Y	YELLOW
B	BLUE
G	GREEN
R	RED
W	WHITE
GR	GRAY

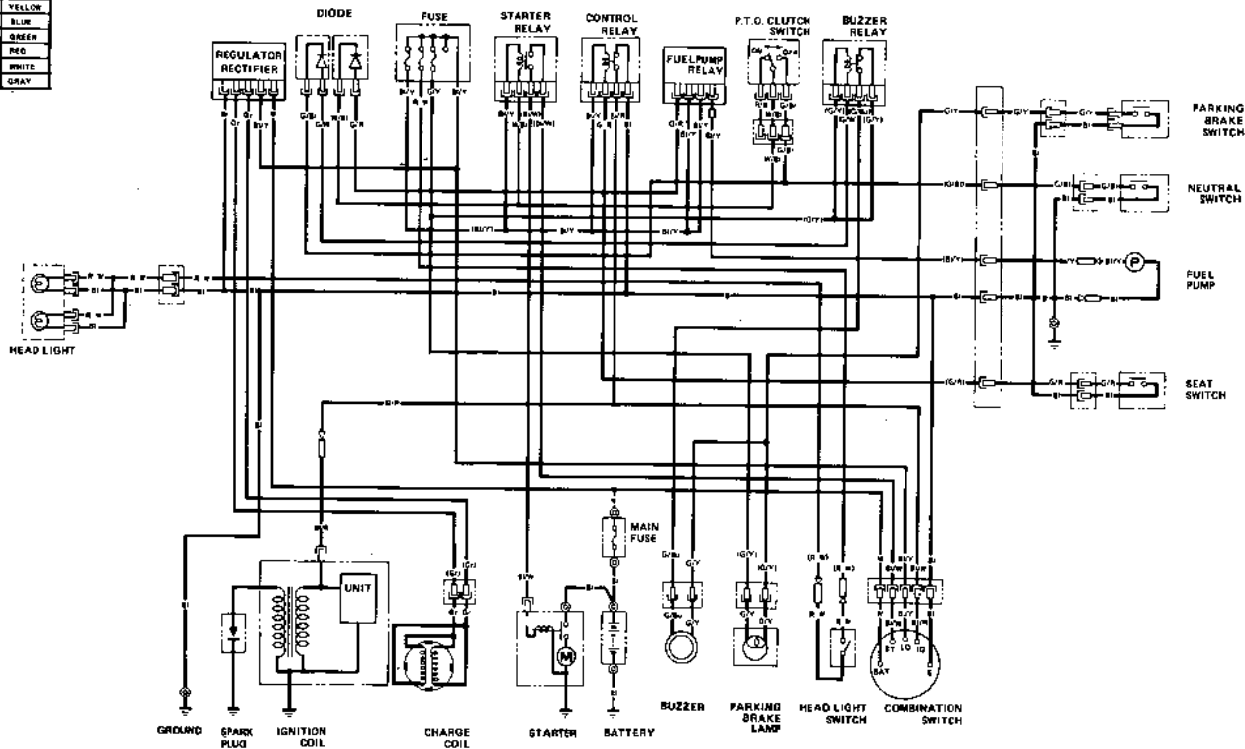

9. TROUBLESHOOTING

Engine fails to start;

1. No fuel. —————> Add fuel.
2. Shift lever in gear. —————> Position shift lever in NEUTRAL.
3. P.T.O. lever engaged. —————> Position blade (P.T.O.) lever in DISENGAGE.
4. Spark plug faulty or —————> Regap plug or replace (see p.43).
improperly gapped.
5. Spark plug wire loose —————> Check spark plug wire.
or disconnected.
6. Fuel not reaching —————> See your authorized HONDA lawn
carburetor. tractor dealer.
7. Discharged battery or —————> Charge battery or retighten terminal.
loose terminal. (see p.45).

Engine loses power;

1. Dirty air cleaner elements. —————> Clean or replace elements (see
p.42).
2. Spark plug faulty or —————> Regap plug or replace.
improperly gapped.
3. Engine overloaded. —————> Shift to lower speed.

Engine overheats;

1. Cooling air intake plugged. —————> Clean cooling air intake (see p.15).
2. Engine overloaded. —————> Shift to lower speed.
3. Low engine oil level. —————> Fill with recommended oil (see
p.16).
4. Spark plug improperly. —————> Regap plug or replace.
gapped

Erratic operation;

1. Dirty fuel. —————> See your HONDA lawn tractor dealer.
2. Dirty air cleaner elements. —————> Clean air cleaner elements.
3. Spark plug faulty or —————> Regap plug or replace.
improperly gapped.

Excessive vibration;

1. Loose blade or engine —————> Retighten blade bolts or engine
mounting hardware. mounting hardware.
2. Blade damaged or out of —————> Replace blade.
balance.

Battery will not charge;

1. Dead cell in battery. —————> Replace battery
2. Loose electrical connec- —————> Check connections and lines.
tions or broken wire.

Uneven mowing;

1. Tractor speed too fast. —————> Shift to lower speed.
2. Grass accumulation —————> Clean deck inside (see p.37).
inside deck.
3. Dull blade. —————> Sharpen blade or replace.
4. Tires improperly inflated. —————> Check tire inflation (see p.22).
5. Mower not level. —————> Check cutter deck mounting.
6. Wrong cutter deck height. —————> Change to proper height.
7. Discharge fan damage. —————> See your authorized HONDA lawn
tractor dealer.
8. Chute clogged (if equipped —————> Empty grass bag and chute.
with optional grass bag).

Clogged cutter deck discharge chute.

1. Wrong blade. —————> Use genuine Honda blade or equivalent.
2. Deck too low. —————> Raise deck and adjust deck height properly.
3. Engine overloaded. —————> Operate at full throttle. Use lower speed range. Set cutter deck higher than desired height for first pass, then cut to desired height on second pass.
4. Grass bags full —————> Empty grass bags.
(Optional part).

Blades do not rotate or stop.

1. Blade drive belt worn or broken. —————> Replace with new belt (see p.50).
2. P.T.O. lever cable cut or out of adjustment. —————> See your authorized HONDA lawn tractor dealer.
3. Faulty P.T.O. clutch assy or worn disk. —————> See your authorized HONDA lawn tractor dealer.

Tractor does not move, or clutch does not engage properly when the transmission is shifted into gear.

1. Faulty clutch assy. —————> See authorized HONDA lawn tractor dealer.
2. Transmission does not shift gear. —————> See authorized HONDA lawn tractor dealer.
3. Abnormal clutch engagement. —————> See authorized HONDA lawn tractor dealer.

10. SPECIFICATIONS

MODEL	HT3810K2
ENGINE	
Model	G400
Type	Side valve, single-cylinder, 4-stroke gasoline engine
Displacement	406 cm ³ (24.8 cu in)
Bore and stroke	86 x 70 mm (3.4 x 2.8 in)
Ignition timing	18° BTDC
Ignition system	Transistorized magneto
Cooling system	Forced air cooled
Engine oil capacity	1.2ℓ (1.27 US qt)
Spark plug	BR4HS (NGK), W14FR-U (ND)
FRAME	
Dimensions	
Length x Width x Height	1755 x 1270 x 1045 mm (69.1 x 49.6 x 41.1 in)
Wheel tread	
Front	720 mm (28.3 in)
Rear	680 mm (26.8 in)
Wheel base	1160 mm (45.7 in)
Cutting width	965 mm (38.0 in)
Cutting height	1-1/2, 2, 2-1/2, 3, 3-1/2, 4 in
Dry weight	247 kg (544.6 lb)
Tire size	Front 15 x 6.00-6, Rear 18 x 8.50-8
Air pressure	Front 1.0kg/cm ² , Rear 0.7 kg/cm ²
Gear selections	5 Forward 1 Reverse
Travel speed (3300 rpm)	
First	1.8 km/h (1.1 mile/h)
Second	2.3 km/h (1.4 mile/h)
Third	3.3 km/h (2.1 mile/h)
Fourth	5.1 km/h (3.2 mile/h)
Fifth	8.6 km/h (5.4 mile/h)
Reverse	2.9 km/h (1.8 mile/h)
Fuel tank capacity	7.1 ℓ (1.88 US gal)
Battery	Std 12V30A. Opt 12V35A

NOTE: Specifications are subject to change without notice.

11. WARRANTY SERVICE

Owner Satisfaction

Your satisfaction and goodwill are important to your dealer and to us. All Honda warranty details are explained in the Distributor's Limited Warranty. Normally, any problems concerning the product will be handled by your dealer's service department. If you have a warranty problem that has not been handled to your satisfaction, we suggest you take the following action:

- Discuss your problem with a member of dealership management. Often complaints can be quickly resolved at that level. If the problem has already been reviewed with the Service Manager, contact the owner of the dealership or the General Manager.
- If your problem still has not been resolved to your satisfaction, contact the Power Equipment Customer Relations Department of American Honda Motor Co., Inc.

American Honda Motor Co., Inc.
Power Equipment Customer Relations Department
P.O. Box 50
Gardena, California 90247-0805
Telephone: (213) 604-2400

We will need the following information in order to assist you:

- Your name, address, and telephone number
- Product model and serial number
- Date of purchase
- Dealer name and address
- Nature of the problem

After reviewing all the facts involved, you will be advised of what action can be taken. Please bear in mind that your problem will likely be resolved at the dealership, using the dealer's facilities, equipment, and personnel, so it is very important that your initial contact be with the dealer.

Your purchase of a Honda product is greatly appreciated by both your dealer and American Honda Motor Co., Inc. We want to assist you in every way possible to assure your complete satisfaction with your purchase.

MEMO

HONDA
HONDA MOTOR CO., LTD. TOKYO, JAPAN

31750713
00X31-750-7130

K2    5009408
PRINTED IN JAPAN