

**HONDA**

**Power**

**Equipment**

# Owner's Manual

## Rotary Mower

HRS216PDA • HRS216SDA



**HONDA**

***Harmony II***

*¿Necesita un manual en Español? Vea a la página 55.*

Keep this owner's manual handy, so you can refer to it any time, and make sure the manual stays with the lawn mower if you sell it.

This owner's manual is considered a permanent part of the lawn mower and should remain with the lawn mower if resold.

The information and specifications included in this publication were in effect at the time of approval for printing. Honda Power Equipment Mfg., Inc. reserves the right, however, to discontinue or change specifications or design at any time without notice and without incurring any obligation whatever.

Honda lawn mowers meet Consumer Product Safety Commission (CSPC) blade safety requirements for walk-behind rotary mowers.



## **WARNING:**



The engine exhaust from this product contains chemicals known to the State of California to cause cancer, birth defects or other reproductive harm.

Congratulations on your selection of a Honda lawn mower! We are certain you will be pleased with your purchase of one of the finest lawn mowers on the market.

We want to help you get the best results from your new mower and to operate it safely. This manual contains the information on how to do that; please read it carefully.

As you read this manual, you will find information preceded by a

**NOTICE**

symbol. That information is intended to help you avoid damage to your mower, other property, or the environment.

We suggest you read the Distributor's Limited Warranty (p. 48) and Emission Control System Warranty (p. 52) to fully understand coverage and your responsibilities of ownership.

When your mower needs scheduled maintenance, keep in mind that an authorized Honda servicing dealer is specially trained in servicing Honda mowers and is supported by the parts and service divisions of American Honda. Your Honda dealer is dedicated to your satisfaction and will be pleased to answer your questions and concerns.

Best Wishes,  
Power Equipment Division  
American Honda Motor Co., Inc.

# INTRODUCTION

---

## A FEW WORDS ABOUT SAFETY

Your safety, and the safety of others, are very important. And using this lawn mower safely is an important responsibility.

To help you make informed decisions about safety, we have provided operating procedures and other information on labels and in this manual. This information alerts you to potential hazards that could hurt you or others.

Of course, it is not practical or possible to warn you about all the hazards associated with operating or maintaining a lawn mower. You must use your own good judgment.

You will find important safety information in a variety of forms, including:

- **Safety Labels**— on the lawn mower.
- **Safety Messages**— preceded by a safety alert symbol  and one of three words: DANGER, WARNING, or CAUTION.

These signal words mean:

 DANGER

You **WILL** be **KILLED** or **SERIOUSLY HURT** if you don't follow instructions.

 WARNING

You **CAN** be **KILLED** or **SERIOUSLY HURT** if you don't follow instructions.

 CAUTION

You **CAN** be **HURT** if you don't follow instructions.

- **Safety Headings**— such as Important Safety Reminders or Important Safety Precautions.
- **Safety Chapter**— such as MOWER SAFETY.
- **Instructions**— how to use this mower correctly and safely.

This entire book is filled with important safety information — please read it carefully.

# CONTENTS

<b>MOWER SAFETY</b> .....	4
Important information about some specific hazards, and what you can do to prevent injury.	
<b>CONTROLS</b> .....	7
Identification of components and information about how the controls work.	
<b>BEFORE OPERATION</b> .....	11
How to fuel and check your mower to be sure it is ready. How to prepare your lawn and yourself before you begin mowing.	
<b>OPERATION</b> .....	17
Starting and stopping the engine, safe mowing practices, and mowing tips.	
<b>TRANSPORTING</b> .....	27
How to load and carry your mower safely.	
<b>MAINTENANCE</b> .....	28
When and how to perform routine inspection, service, and adjustments to keep your mower in good operating condition.	
<b>TROUBLESHOOTING</b> .....	39
What to check if you have a problem with your mower.	
<b>STORAGE</b> .....	41
How to protect your mower from rust and corrosion, and ensure it will start easily when used again.	
<b>SPECIFICATIONS</b> .....	45
Dimensions, capacities, and other technical information.	
<b>ASSEMBLY &amp; PDI</b> .....	47
How to assemble the mower.	
<b>ADDITIONAL INFORMATION</b> .....	48
Additional information, Honda publications available to you, warranty, and how to contact us if you have a question or a warranty repair problem.	
<b>INDEX</b> .....	58
<b>QUICK REFERENCE INFORMATION</b> .....	inside back cover

# MOWER SAFETY

## IMPORTANT SAFETY INFORMATION

Most accidents with walk-behind mowers can be prevented if you follow all instructions in this manual and on the mower. The most common hazards, according to accident statistics, are discussed below, along with the best way to protect yourself and others.

### **Avoid Rotating Blades**

Rotating blades can cause serious cuts and even amputate fingers, hands, toes, or feet. Keep away from the mower deck whenever the engine is running. If you need to adjust the cutting height, or work around the deck for any other reason, always shut off the engine. Wear heavy gloves and disconnect the spark plug cap when you need to clean the mower deck or handle the blade.

### **Clear Mowing Area**

Mower blades can throw rocks and other objects with enough force to cause serious injury. Before mowing, carefully inspect the area and remove all sticks, stones, pieces of wire, and other loose objects. Never operate the blade over gravel.

### **Keep Shields in Place**

Guards and shields are designed to protect you from being hit by thrown objects and from hot engine parts and moving components. For your safety and the safety of others, keep all shields in place when the engine is running.

### **Refuel with Care**

Gasoline is extremely flammable and gasoline vapor can explode. Refuel only outdoors, in a well-ventilated area, with the engine OFF. Never smoke near gasoline, and keep other flames and sparks away. Always store gasoline in an approved container.

### **Wear Protective Clothing**

Wearing protective clothing will reduce your risk of injury. Long pants and eye protection reduce the risk of injuries from thrown objects. Sturdy shoes with aggressive soles will help protect your feet and give you better traction on slopes or uneven ground.

### **Turn Engine Off When Not Mowing**

If you need to leave the mower for any reason, even just to inspect the lawn ahead, always turn the engine OFF.

## IMPORTANT MESSAGE TO PARENTS

YOUR CHILDREN'S SAFETY IS VERY IMPORTANT to Honda. That's why we urge you to read this message before letting your youngster operate this lawn mower. Lawn mowers are tools, not toys. As with any equipment, bad judgments can result in serious injuries. You can help prevent accidents by making good decisions about if, when, and how your youngster operates this equipment.

The first question you'll need to ask is whether your youngster is capable of operating this mower safely. Remember, young people vary widely, and **AGE IS NOT THE ONLY FACTOR**.

Physically, a youngster must be **LARGE ENOUGH AND STRONG ENOUGH** to easily start the mower and control its direction. The youngster also needs enough size, strength, and coordination to comfortably reach and operate the controls.

Another, tougher question you need to ask is if your youngster has enough **MATURITY AND RESPONSIBILITY** to safely operate this mower. Does the young person think through problems and come to logical solutions? Be honest! Anyone who takes unnecessary risks and doesn't obey rules should not operate this lawn mower.

If you decide that your son or daughter can handle the mower safely, **CAREFULLY READ THE OWNER'S MANUAL** with your youngster. Make sure you both understand all instructions and safety information. Also, be sure your youngster wears sturdy shoes and other protective clothing when operating or handling the mower.

**SUPERVISION** is also very important. Walk with your youngster during the first few minutes of mowing. Even after the youngster has become confident with the mower, do not let the young person use the mower without good adult supervision. An adult should also be present during refueling and maintenance. In fact, it's up to parents to make sure that the mower is properly maintained and kept in safe operating condition.

By always placing safety first, your youngster will acquire useful skills and a sense of accomplishment. And you'll both get the best results from your lawn mower.

# MOWER SAFETY

## SAFETY LABEL LOCATIONS

The labels shown here contain important safety information. Please read them carefully. These labels are considered permanent parts of your mower. So if a label comes off or becomes hard to read, contact an authorized Honda dealer for a replacement.

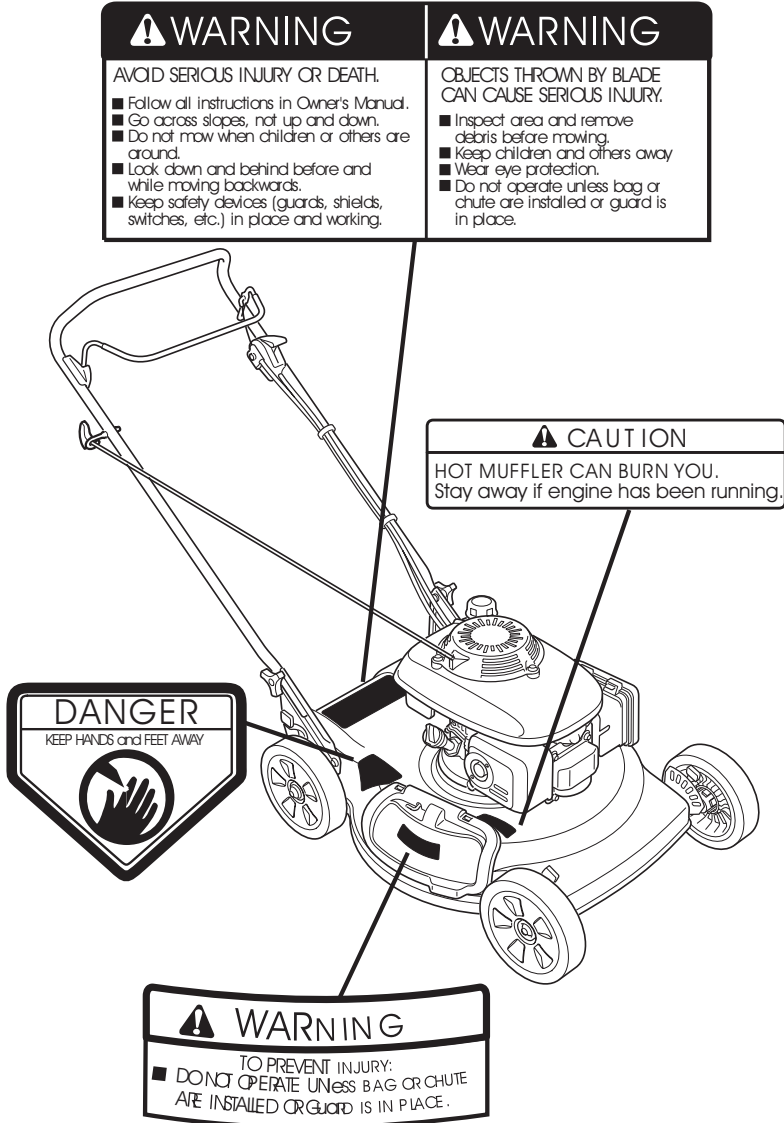



# CONTROLS

## COMPONENT IDENTIFICATION

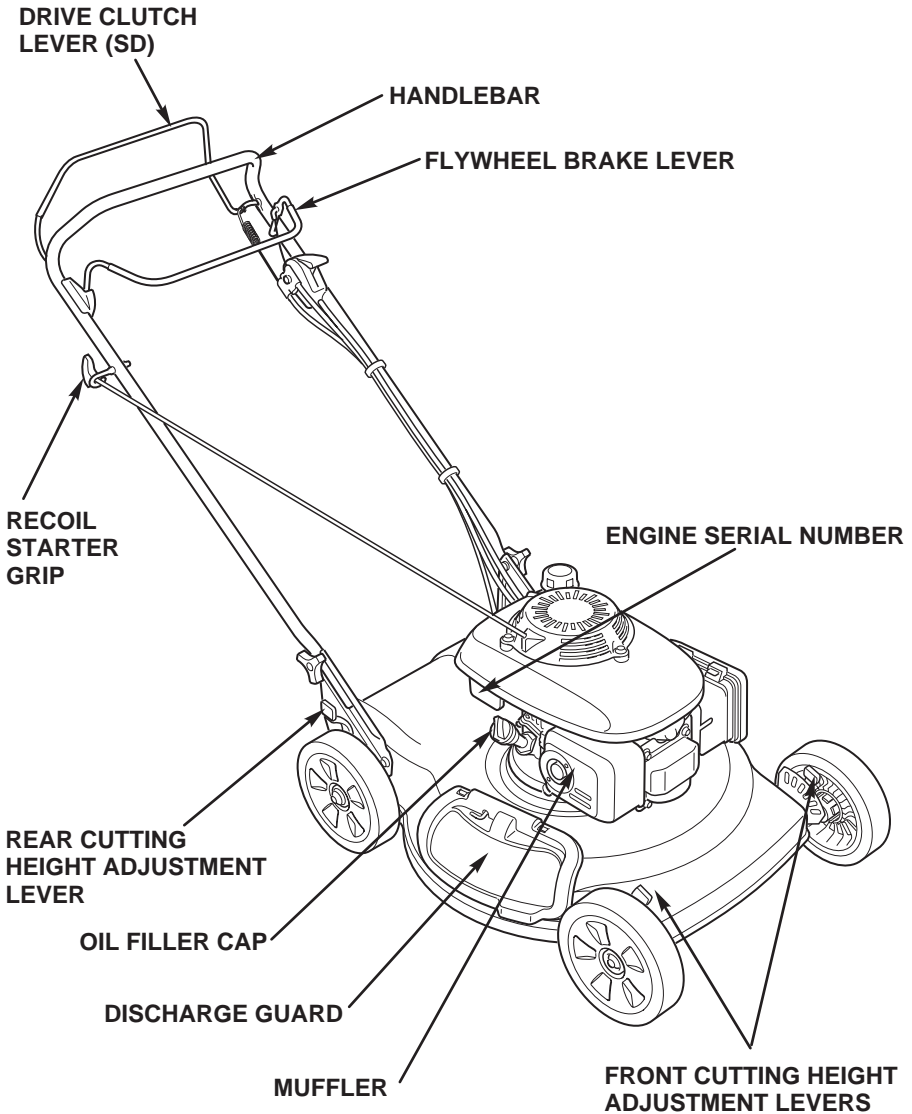

HRS216PD: Manually propelled (push)  
HRS216SD: Self-propelled, single speed

# CONTROLS

---

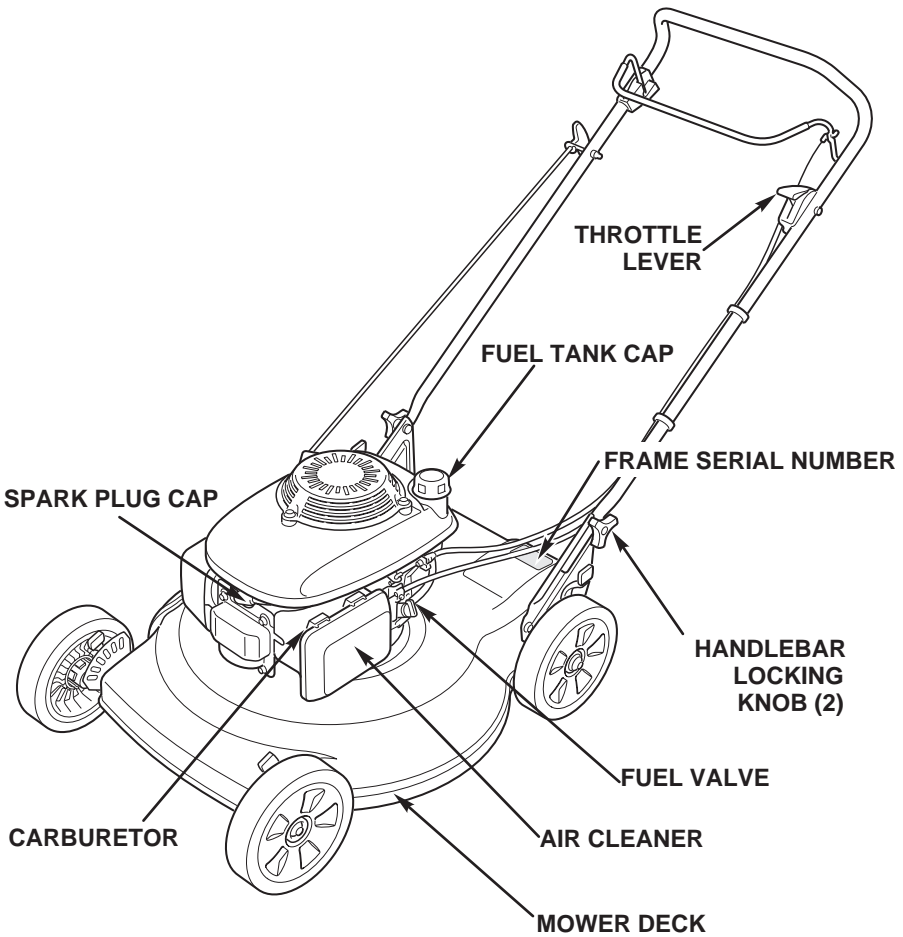

Record the frame and engine serial numbers in the space below. You will need these serial numbers when ordering parts and when making technical or warranty inquiries (see page ).

**Frame serial number:** MZB\_\_ - \_\_\_\_\_

**Engine serial number:** GJAE - \_\_\_\_\_

## DESCRIPTION OF CONTROLS

### Fuel Valve

The fuel valve opens and closes the fuel passage from the fuel tank to the carburetor. The fuel valve must be ON to start and operate the mower. The fuel valve should be kept OFF when the mower is not in use.

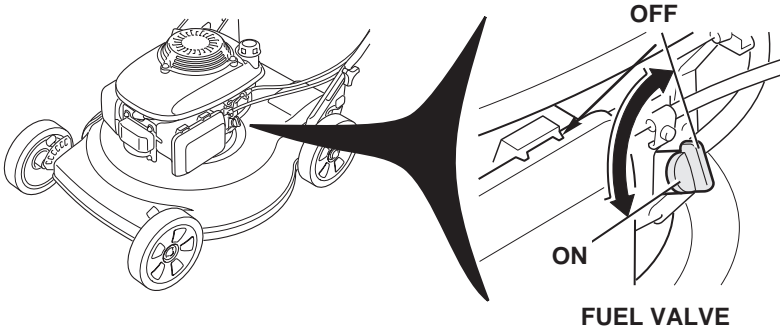

### Throttle Lever

 CHOKE --- For starting a cold engine.

 FAST ----- For restarting a warm engine and for mowing.

 SLOW ----- For idling the engine.

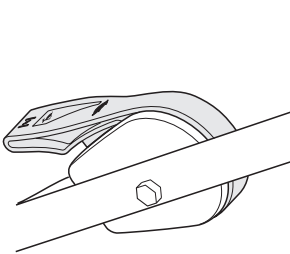

CHOKE

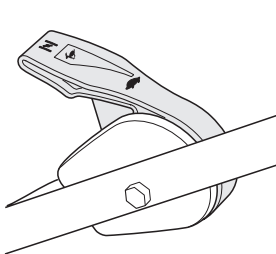

FAST

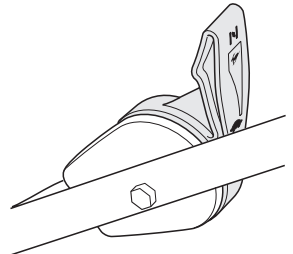

SLOW

# CONTROLS

## Flywheel Brake Lever

This lever is connected to the engine flywheel brake and the ignition switch. The engine will not start unless this lever is pulled backward.

FLYWHEEL BRAKE LEVER

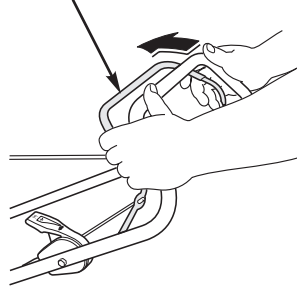

## Drive Clutch Lever (SD)

The drive clutch lever engages (push forward) and disengages (release) the transmission that drives the rear wheels. The drive clutch lever should only be engaged after the engine has been started.

DRIVE CLUTCH LEVER (SD)

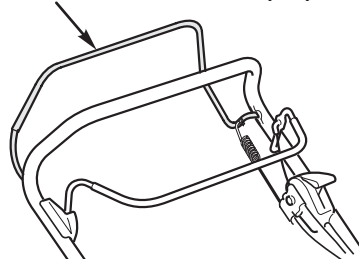

## Cutting Height Adjustment Levers

There are six approximate settings [1 ~ 3-1/2 in. (25 ~ 87 mm)]. The adjusters move back to lower and forward to raise the mower deck. For the best overall lawn finish, each wheel should be adjusted to the same position.

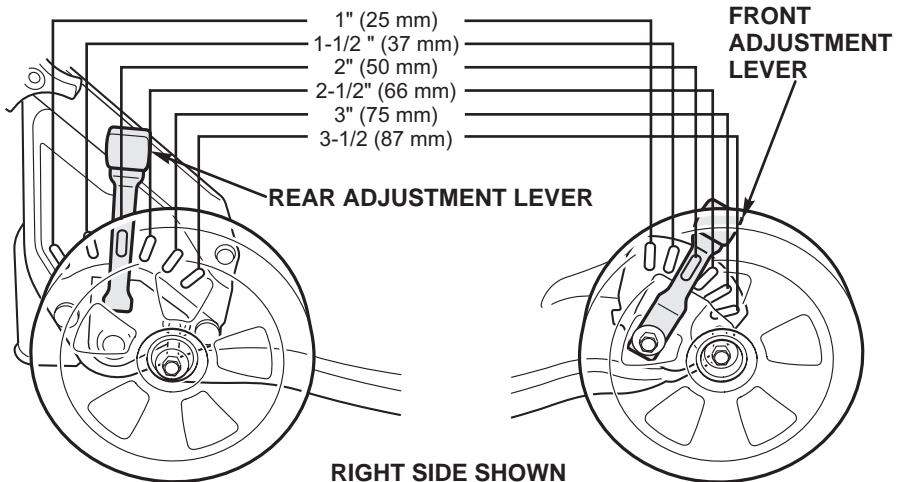

# BEFORE OPERATION

## ARE YOU READY TO MOW?

Be sure to wear protective clothing. Long pants and eye protection can lower your risk of injury from thrown objects. Wear footwear that protects your feet and won't let you slip if you mow on slopes or uneven ground.

## CHECK YOUR LAWN

For your safety and for the safety of others, always inspect the area before mowing.

### Objects

Anything which can be picked up by the blade and thrown is a potential hazard to you and others. Look for things like stones, sticks, bones, and wire. Remove them from the mowing area.

### People and Pets

People and animals near the mowing area can move into your path or into a position where they could be struck by thrown objects. Clear the area of people and pets, especially children. Their safety is your responsibility.

### Lawn

Check the length and condition of the grass, so you will know what cutting height and mowing speed to use.

Avoid mowing wet grass. Not only will wet grass clog your mower deck and collect in clumps on the lawn, it also gives poor traction, increasing your risk of losing your footing.

# BEFORE OPERATION

## CHECK YOUR MOWER

### Blade

1. Turn the fuel valve to OFF (page 9). Disconnect the spark plug cap from the spark plug (page 36).
2. Tilt the mower to the right, so the carburetor side is up. This will help to prevent fuel leakage and hard starting.
3. Inspect the blade(s) for wear and damage

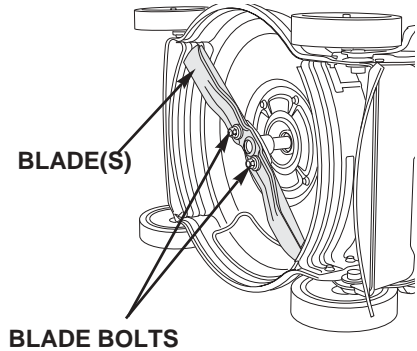

### **⚠ WARNING**

A worn, cracked, or damaged blade can break, and pieces of the damaged blade can become dangerous projectiles.

Thrown objects can cause serious injury.

Inspect the blade(s) regularly. Do not operate the mower with a worn or damaged blade.



### **NORMAL    EXCESSIVELY WORN    BENT    CRACKED**

A dull blade can be sharpened, but a blade that is worn out, bent, cracked, or otherwise damaged must be replaced. A worn or damaged blade can break, causing blade pieces to be thrown from the mower.

When a blade needs sharpening or replacement take the lawn mower to an authorized Honda servicing dealer. Or, if you have a torque wrench, you can remove and install the blade yourself (page 38).

Check that the blade bolts are tight (see page 38).

A dull blade can be sharpened, but a blade that is worn out, bent, cracked, or otherwise damaged must be replaced. A worn or damaged blade can break, causing blade pieces to be thrown from the mower.

When a blade needs sharpening or replacement take the lawn mower to an authorized Honda servicing dealer. Or, if you have a torque wrench, you can remove and install the blade yourself (see pages 38).

Check that the blade bolts are tight (see page ).

## Engine Oil Level

Check the engine oil level with the engine stopped and the mower on a level surface.

1. Remove the oil filler cap, and wipe the dipstick clean.
2. Insert and remove the dipstick without screwing it into the filler neck. Check the oil level shown on the dipstick.
3. If the oil level is low, add the recommended oil (see page 34) to reach the upper limit mark on the dipstick. Do not overfill.

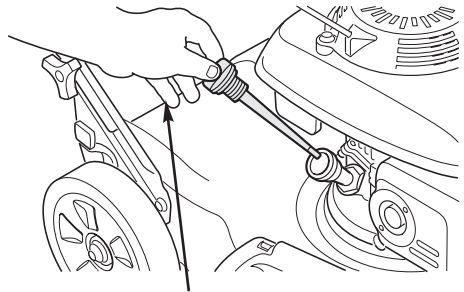

FILLER CAP/DIPSTICK

4. After checking the engine oil level, screw in the filler cap/dipstick securely.

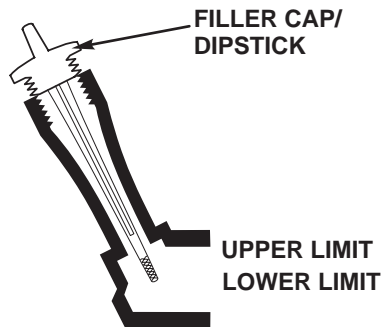

FILLER CAP/  
DIPSTICK

UPPER LIMIT  
LOWER LIMIT

# BEFORE OPERATION

---

## Fuel

Fuel tank capacity: 0.29 US gal (1.1 ℓ)

Refuel in a well-ventilated area before starting the engine. If the engine has been running, allow it to cool. See page 37 for fuel recommendations and page 56 for information on oxygenated fuels.

Remove the fuel tank cap and check the fuel level. Refill the tank if the fuel level is low. Refuel carefully to avoid spilling fuel. Do not overfill; there should be no fuel in the filler neck. After refueling, tighten the fuel tank cap securely.

### WARNING

Gasoline is highly flammable and explosive.

You can be burned or seriously injured when handling fuel.

- Stop the engine and keep heat, sparks, and flame away.
- Handle fuel only outdoors.
- Wipe up spills immediately.

Never refuel the mower inside a building where gasoline fumes may reach flames or sparks. Keep gasoline away from appliance pilot lights, barbecues, electric appliances, power tools, etc.

Spilled fuel is not only a fire hazard, it causes environmental damage. Wipe up spills immediately.

### NOTICE

Fuel can damage paint and plastic. Be careful not to spill fuel when filling your fuel tank. Damage caused by spilled fuel is not covered under warranty.

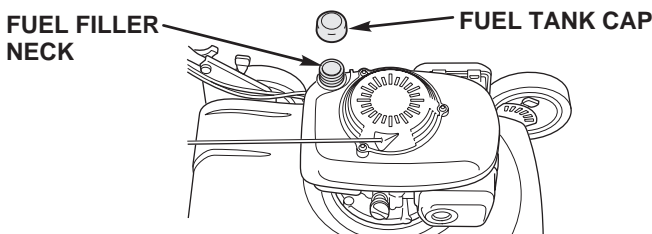



## Air Cleaner Inspection

Make sure the air filter is clean and in good condition. A dirty air filter will restrict air flow to the carburetor, reducing engine performance. Refer to page 35 for air cleaner service.

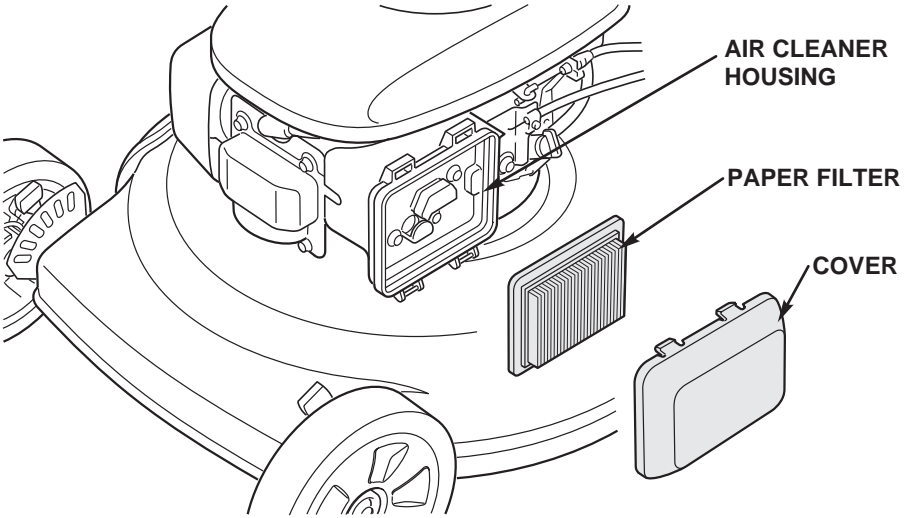

## Mulching or Side Discharge

The mower can be used to mulch or side discharge grass clippings.

To mulch, make sure the side discharge chute is not installed, and the side door on the mower deck is fully closed.

To discharge the clippings from the side door, stop the engine, lift the side door up and install the side discharge chute as shown.

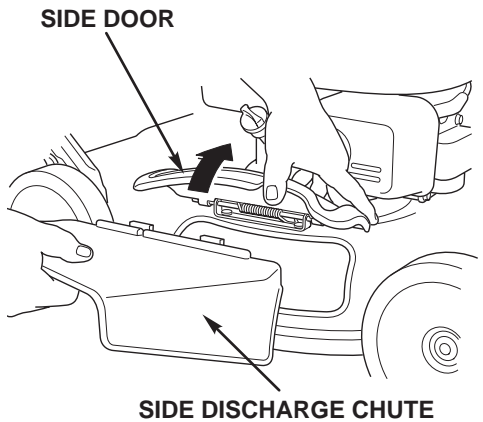

# BEFORE OPERATION

---

## Cutting Height

Check the mower deck cutting height settings, and be sure that all four adjustment levers are set to the same cutting height position. The lowest setting is approximately 1 inch (25 mm) and the highest setting is 3-1/2 inches (87 mm). Each position increments about 1/2 inch (13 mm).

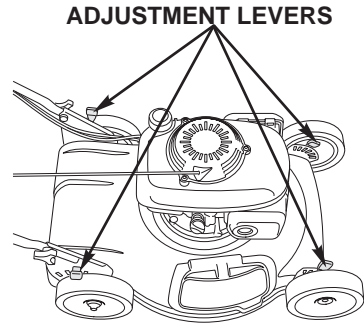

To adjust cutting height, pull each adjustment lever toward the wheel, and move it into another notch.

If you are not sure what cutting height to select, start with a high setting and check the appearance of the lawn after mowing a small area. Then readjust cutting height if necessary.

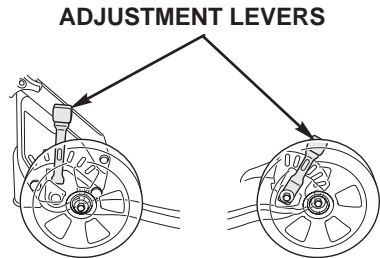

# OPERATION

## MOWING PRECAUTIONS

Before operating the mower for the first time, please review the **MOWER SAFETY** beginning on page 4 and the previous chapter, titled **BEFORE OPERATION**.

Even if you have operated other mowers, take time to become familiar with how this mower works and practice in a safe area until you build up your skills.

For your safety, avoid starting or operating the engine in an enclosed area such as a garage. Your mower's exhaust contains poisonous carbon monoxide gas which can collect rapidly in an enclosed area and cause illness or death.

## STARTING THE ENGINE

The blade turns when you operate the starter. It is easiest to start the engine in a clear or mowed area where the blade can turn freely.

1. Turn the fuel valve to the ON position.

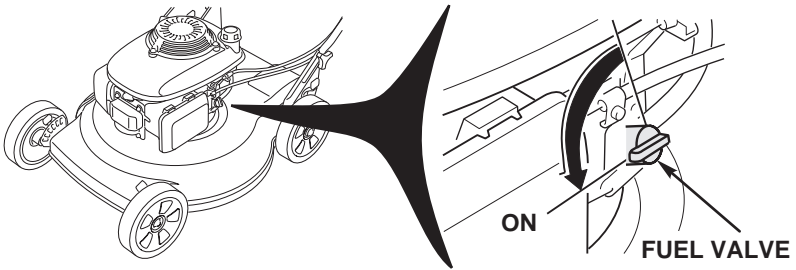

2. Move the throttle lever to the proper starting position.

**COLD ENGINE:**

Move the throttle lever to the **CHOKE** position.

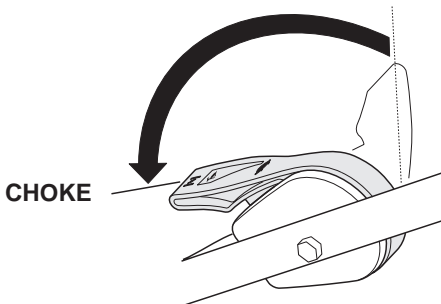

# OPERATION

## WARM ENGINE:

Move the throttle to FAST.

1. **SD:** Release the drive clutch lever. If the drive clutch lever is engaged, the mower will move forward when you operate the starter.
2. Pull back on the flywheel brake lever and hold it against the handlebar.
3. Pull the starter grip lightly until you feel resistance, then pull briskly. Return the starter grip gently.

Keep your hands and feet away from the mower deck at all times when starting and running the engine.

Continue to hold the flywheel brake lever against the handlebar; the engine will stop if you release the lever.

4. If the **CHOKER** position was used during starting, move the throttle lever away from the **CHOKER** position as soon as the engine warms up enough to run **FAST** smoothly. Set the throttle lever at **FAST** to mow or at **SLOW** to idle.

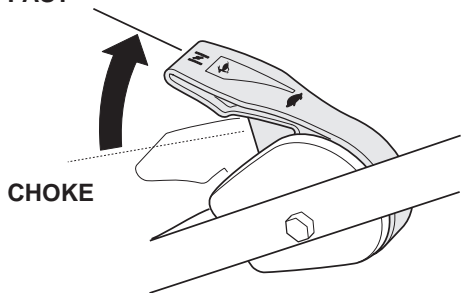
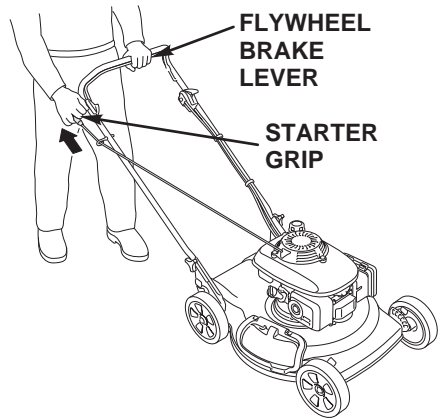
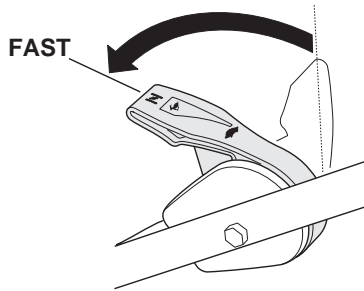

## OPERATING THE CONTROLS FOR MOWING

### Throttle Lever

For best cut quality, always mow with the throttle lever in the FAST position. When the blade rotates at the preset fast speed, it creates a strong fan action that lifts and cuts grass more efficiently. Do not try to increase the preset engine speed, the blade could fracture and come apart.

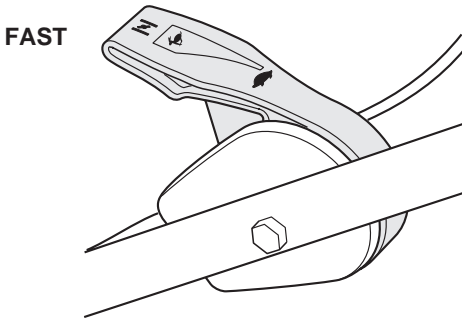

When you need to leave the mower for any reason, always turn the engine OFF by releasing the flywheel brake lever.

### Flywheel Brake Lever

The lever must be pulled backward against the handlebar to start the engine. The blade starts to rotate when the lever is pushed forward against the handlebar and the recoil starter grip is pulled.

Continue to hold the lever against the handlebar to keep the engine running and the blade rotating.

Release the lever to stop the engine and stop blade rotation.

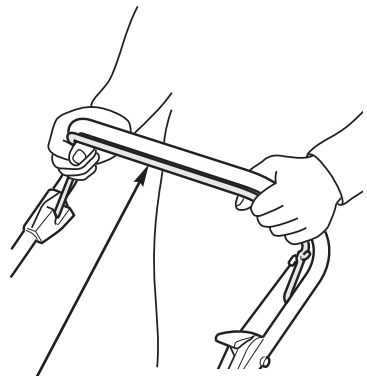

**FLYWHEEL BRAKE LEVER**

# OPERATION

---

## Drive Clutch Lever (SD)

Push the drive clutch lever forward and hold it against the handlebar to propel the mower forward.

Release the drive clutch lever to stop the mower's forward movement.

Always release the drive clutch lever before starting the engine. If the drive clutch is engaged, the mower will move forward when you operate the starter.

DRIVE CLUTCH LEVER (SD)

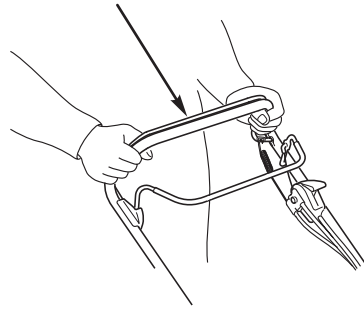

Operate the drive clutch lever with a quick and complete motion, so the drive clutch is either fully engaged or released. Hold the drive clutch lever against the handlebar during self-propelled mowing. This will help to extend the service life of the clutch mechanism.

## STOPPING THE ENGINE

1. Move the throttle lever to the SLOW position.

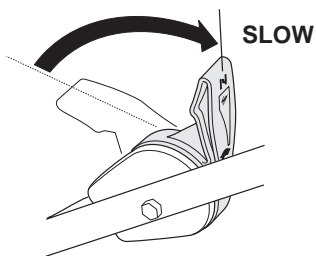

2. Release the drive clutch lever (SD).

DRIVE CLUTCH LEVER (SD)

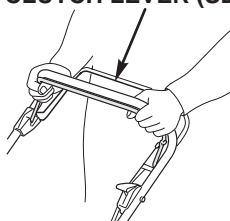

3. Release the flywheel brake lever.

FLYWHEEL  
BRAKE  
LEVER

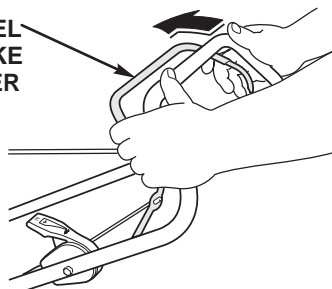

4. When the mower is not in use, turn the fuel valve to OFF.

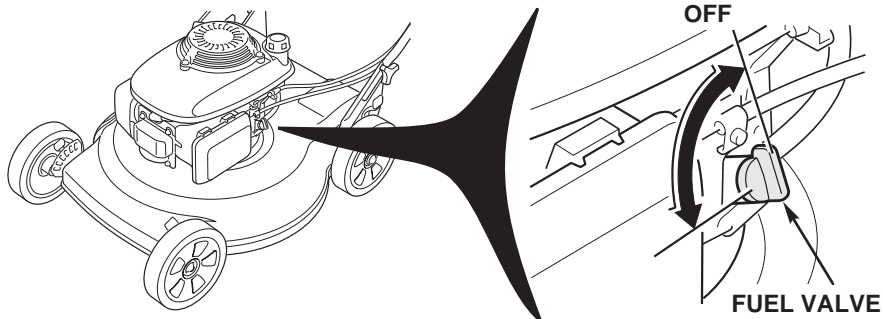

# OPERATION

---

## SAFE MOWING PRACTICES

For your safety, keep all four wheels on the ground, and be careful to avoid losing your footing and your control of the mower. Keep a firm grip on the handlebar, and walk, never run, with the mower. Be very careful when mowing uneven or rough ground.

If stuck, do not kick or shove the mower with your foot. Use the handlebar to control the mower.

### WARNING

The blade is sharp and spins at high speed.

A spinning blade can cut you severely and can amputate fingers and toes.

- Wear protective footwear.
- Keep your hands and feet away from the mower deck while the engine is running.
- Stop the engine before performing any adjustment, inspection, or maintenance.

### Slopes

Mow across slopes, not up and down. Avoid steep slopes (more than 20°), and be careful when changing direction. Mowing on a slope when the grass is damp or wet could cause you to slip, fall, and lose control of the mower.

**MAXIMUM SLOPE 20 °**

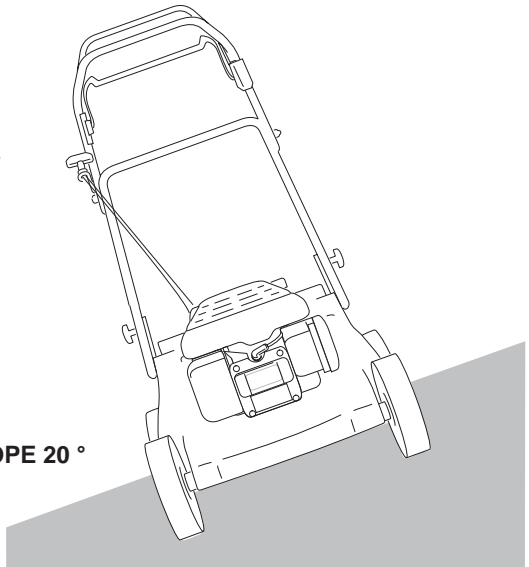



## Obstacles

Use the side of the mower to cut close to large obstacles, such as fences or walls.

Release the drive clutch lever to disengage the drive when mowing around trees and other obstacles. Push the mower around obstacles for better directional control. Be careful when mowing over obstacles embedded in the lawn, such as sprinkler heads, paving, edging, etc. Avoid anything that sticks up above the surface of the lawn.

If the blade hits something, or if the mower starts to vibrate, stop the engine immediately, disconnect the spark plug cap, and check for damage (see page 12). Striking objects may damage the blade, bend the crankshaft, and/or break the mower deck or other components. Vibration usually indicates serious trouble.

### WARNING

A worn, cracked, or damaged blade can break, and pieces of the damaged blade can become dangerous projectiles.

Thrown objects can cause serious injury.

Inspect the blade regularly, and do not operate the mower with a worn or damaged blade.

The Distributor's Limited Warranty does not cover parts damaged by accident or collision.

## Gravel and Loose Objects

Gravel, loose stones, and landscaping material can be picked up by the mower and thrown many feet with enough force to cause serious personal injury and/or property damage. The best way to prevent potential injury from thrown objects is to release the flywheel brake lever to stop the blade before reaching areas with gravel, loose stones, or landscaping material.

# OPERATION

---

## MOWING TIPS

### When to Mow

Most grasses should be mowed when they have grown  $\nearrow$  to 1 inch above their recommended height.



More frequent mowing is required for mulching than for bagging. For best results, you may need to mow the lawn twice a week during the growing season.

### Cutting Height

Consult a local nursery or lawn and garden center for cutting height recommendations and advice about specific types of grasses and growing conditions in your area.



**LONG ENOUGH**

If you look closely, you'll see that most grass has stems and leaves. If you cut off the leaves, you'll scalp the lawn. Let the grass recover between mowings. Your mower will work better, and your lawn will look better.



**TOO SHORT**

If your grass gets too tall, cut it once at the highest cutting height setting, then mow again in 2 or 3 days. Don't take off more than one third of total grass height in any one mowing, or brown patches may develop.

Cutting height adjustment is explained on page 10.

### Cutting Width

For an even lawn finish, overlap each mowing swath by a few inches. If the grass is very tall or thick, use more overlap and a narrower mowing swath.

## **Blade Speed**

The blade must spin very fast to cut properly. Always use the FAST throttle setting. If engine speed drops, it could mean the engine is being overloaded by the blade trying to cut too much grass. Mow a narrower swath, move the mower slower, install the discharge chute, or raise the cutting height.

## **Blade Sharpness**

A sharp blade cuts cleanly. A dull blade tears the grass, leaving shredded ends that turn brown. When your blade doesn't cut cleanly anymore, have it sharpened or replaced.

## **Dry Grass**

If the ground is too dry, mowing will stir up a lot of dust. Besides being unpleasant to work in, too much dust will clog the carburetor air filter. If dust is a problem, water your lawn the day before mowing. Mow when the grass is dry to your touch, but the soil is still moist.

## **Wet Grass**

Wet grass is slippery and can make you lose your footing. Also, wet grass clippings will clog the mower deck and collect in clumps on the lawn. Always wait for wet grass to dry before mowing.

## **Fallen Leaves**

When equipped with the optional grass bag, your mower can be used to pick up fallen leaves for disposal. If using the mower to bag large amounts of fallen leaves, and not for mowing, set the cutting height adjustment levers so the front of the mower deck is one or two settings higher than the rear.

If you want to mulch fallen leaves into your lawn, don't let the leaf cover get too deep before you begin. For best results, start mulching while grass still shows through the leaf cover. In places where fallen leaves completely cover the grass, remove the leaves by raking, or install a grass bag, so your mower can pick them up for disposal.

## **Clogged Mower Deck**

Before clearing a clogged mower deck, stop the engine and turn the fuel valve to the OFF position. With the spark plug cap disconnected, tilt the mower so the carburetor side is up. Clear a clogged deck with a stick, not your hands.

# OPERATION

---

## Mowing Patterns

Your Honda mower will work most efficiently if you use the following mowing patterns as much as possible. Mower deck and equipment design, and the direction in which the blade rotates, cause these mowing patterns to give the best results.

### Mulching

Use a counterclockwise mowing pattern. If the lawn has an irregular shape, or many obstacles, divide it into sections where you can use counterclockwise mowing patterns.

### Side-Discharge Mowing

Where possible, use the same mowing pattern recommended for mulching. If the lawn has an irregular shape, or many obstacles, divide it into sections where clippings will be discharged away from uncut areas. This will prevent clippings from piling up in the path of the mower.

### Bagging

(Requires optional grass bag kit)

Use a clockwise mowing pattern. This will give the best bagging performance, leaving the least amount of clippings on the lawn.

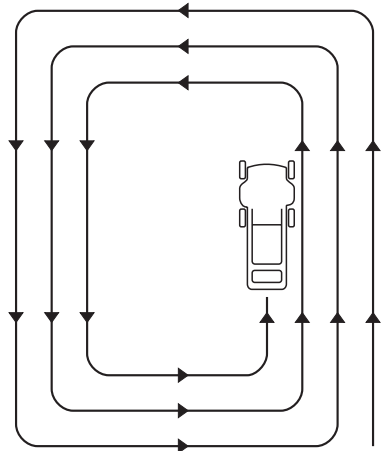

**MULCHING & SIDE DISCHARGE PATTERN**

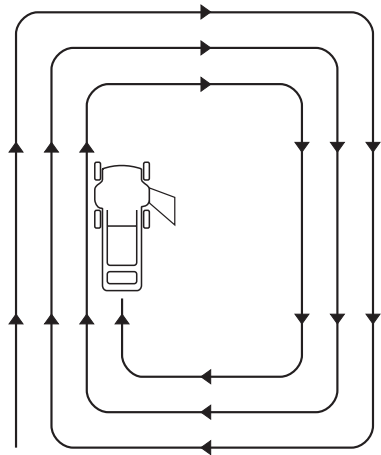

**BAGGING PATTERN**

# TRANSPORTING

## BEFORE LOADING

If the engine has been running, allow it to cool for at least 15 minutes before loading the mower on the transport vehicle. A hot engine and exhaust system can burn you and can ignite some materials.

Turn the fuel valve to OFF. This will prevent carburetor flooding and reduce the possibility of fuel leakage.

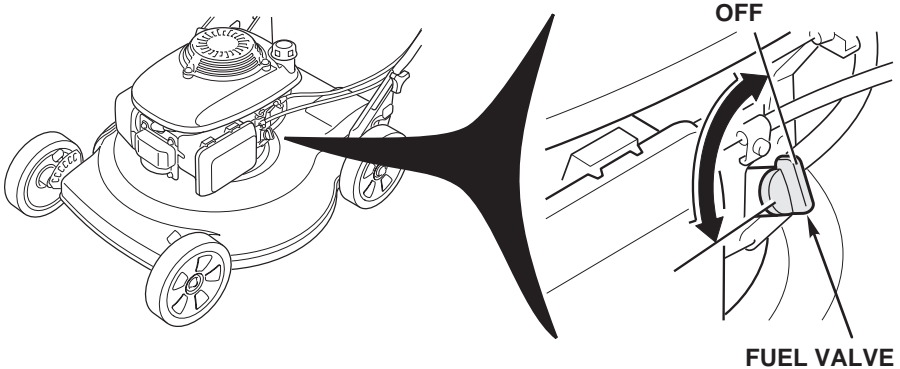

If equipped, remove the grass bag.

## LOADING AND UNLOADING

If a suitable loading ramp is not available, two people should lift the mower on and off the transport vehicle while holding the mower level.

Position the mower so all four wheels are on the bed of the transport vehicle. Tie the mower down with rope or straps, and block the wheels. Keep the tie-down rope or straps away from the controls, adjustment levers, cables, and the carburetor.

The handlebar can be folded so the mower will take up less space (see page 43).

# MAINTENANCE

## THE IMPORTANCE OF MAINTENANCE

Good maintenance is essential for safe, economical, and trouble-free operation. It will also help reduce air pollution.

### WARNING

Improper maintenance, or failure to correct a problem before operation, can cause a malfunction in which you can be seriously hurt or killed.

Always follow the inspection and maintenance recommendations and schedules in this owner's manual.

To help you properly care for your mower, the following pages include a maintenance schedule, routine inspection procedures, and simple maintenance procedures using basic hand tools. Other service tasks that are more difficult, or require special tools, are best handled by professionals and are normally performed by a Honda technician or other qualified mechanic. The maintenance schedule applies to normal operating conditions. If you operate your mower under severe conditions, such as sustained high-load or high-temperature operation, or use in unusually wet or dusty conditions, consult your servicing dealer for recommendations applicable to your individual needs and use.

Maintenance, replacement, or repair of the emission control devices and systems may be performed by any engine repair establishment or individual, using parts that are "certified" to EPA standards.

## MAINTENANCE SAFETY

Some of the most important safety precautions follow. However, we cannot warn you of every conceivable hazard that can arise in performing maintenance. Only you can decide whether or not you should perform a given task.

### WARNING

Failure to properly follow maintenance instructions and precautions can cause you to be seriously hurt or killed.

Always follow the procedures and precautions in this owner's manual.

### Safety Precautions

- Make sure the engine is off before you begin any maintenance or repairs. This will eliminate several potential hazards:
  - **Carbon monoxide poisoning from engine exhaust.**  
Be sure there is adequate ventilation whenever you operate the engine.
  - **Burns from hot parts.**  
Let the engine and exhaust system cool before touching.
  - **Injury from moving parts.**  
Do not run the engine unless instructed to do so.
- Read the instructions before you begin, and make sure you have the tools and skills required.
- To reduce the possibility of fire or explosion, be careful when working around gasoline. Use only a nonflammable solvent, not gasoline, to clean parts. Keep cigarettes, sparks, and flames away from all fuel-related parts.

Remember that an authorized Honda servicing dealer knows your mower best and is fully equipped to maintain and repair it.

To ensure the best quality and reliability, use only new, genuine Honda parts or their equivalents for repair and replacement.

# MAINTENANCE

---

## EMISSION CONTROL SYSTEM INFORMATION

### Source of Emissions

The combustion process produces carbon monoxide, oxides of nitrogen, and hydrocarbons. Control of hydrocarbons and oxides of nitrogen is very important because, under certain conditions, they react to form photochemical smog when subjected to sunlight. Carbon monoxide does not react in the same way, but it is toxic.

Honda utilizes lean carburetor settings and other systems to reduce the emissions of carbon monoxide, oxides of nitrogen, and hydrocarbons.

### The U.S and California Clean Air Acts

EPA and California regulations require all manufacturers to furnish written instructions describing the operation and maintenance of emission control systems.

The following instructions and procedures must be followed in order to keep the emissions from your Honda engine within the emission standards.

### Tampering and Altering

Tampering with or altering the emission control system may increase emissions beyond the legal limit. Among those acts that constitute tampering are:

- Removal or alteration of any part of the intake, fuel, or exhaust systems.
- Altering or defeating the governor linkage or speed-adjusting mechanism to cause the engine to operate outside its design parameters.

### Problems that may Affect Emissions

If you are aware of any of the following symptoms, have your engine inspected and repaired by your servicing dealer.

- Hard starting or stalling after starting.
- Rough idle.
- Misfiring or backfiring under load.
- Afterburning (backfiring).
- Black exhaust smoke or high fuel consumption.



## Replacement Parts

The emission control systems on your new Honda engine were designed, built, and certified to conform with EPA and California emission regulations. We recommend the use of genuine Honda parts whenever you have maintenance done. These original-design replacement parts are manufactured to the same standards as the original parts, so you can be confident of their performance. The use of replacement parts that are not of the original design and quality may impair the effectiveness of your emission control system.

A manufacturer of an aftermarket part assumes the responsibility that the part will not adversely affect emission performance. The manufacturer or rebuilder of the part must certify that use of the part will not result in a failure of the engine to comply with emission regulations.

## Maintenance

Follow the maintenance schedule on page 32. Remember that this schedule is based on the assumption that your machine will be used for its designed purpose. Sustained high-load or high-temperature operation, or use in unusually wet or dusty conditions, will require more frequent service.

# MAINTENANCE

## MAINTENANCE SCHEDULE

REGULAR SERVICE PERIOD Perform at every indicated interval		Before Each Use	first month or 5 hours	every year or 25 hours	every 50 hours	every 100 hours	every 150 hours	See page	
Blade condition and blade bolt tightness	Check	O						12	
Engine oil	Check	O						34	
	Change		O		O(1)			33	
Air Cleaner	Check	O						35	
	Clean			O(1)				35	
	Replace						O(1)		
Spark plug	Clean-adjust					O		36	
	Replace						O		
Spark arrester (optional equipment)	Clean-inspect					O		57	
Idle speed	Check-adjust						O(2)	-	
Flywheel brake operation	Inspect					O			
Flywheel brake pad	Check					O(2)		-	
Throttle cable	Adjust					O(2)		-	
Valve clearance	Adjust						O(2)	-	
Fuel tank	Clean						O(2)	-	
Fuel line	Check & replace (if needed)	Every 2 years (2)							-

- (1) Service more frequently when used in dusty areas.
- (2) These items should be serviced by an authorized Honda servicing dealer, unless you have the proper tools and are mechanically proficient. Refer to the Honda shop manual for service procedures.

## ENGINE MAINTENANCE

### Engine Oil Change

Drain the used oil while the engine is warm. Warm oil drains quickly and completely.

1. Turn the fuel valve to OFF to reduce the possibility of fuel leakage (see page 21).
2. Wipe the oil filler area clean, then remove the oil filler cap/dipstick.
3. Place a suitable container next to the mower to catch the used oil, then tilt the mower on its right side. The used oil will drain through the filler neck. Allow the oil to drain completely.

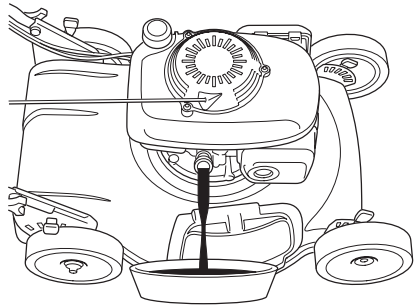

Please dispose of used motor oil and the containers in a manner that is compatible with the environment. We suggest you take it in a sealed container to your local recycling center or service station for reclamation. Do not throw it in the trash, pour it on the ground or down a drain.

4. Fill with the recommended oil. Do not overfill; measure the oil level as shown on page 34.

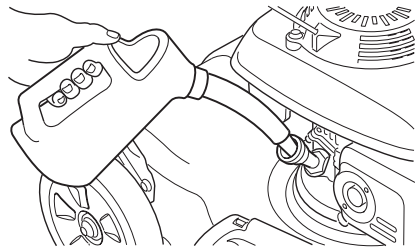

**Engine oil capacity:**  
**0.58 US qt. (0.55 l)**

### NOTICE

Using nondetergent oil can shorten the engine's service life, and using 2-stroke oil can damage the engine.

# MAINTENANCE

5. After changing the engine oil, and before starting the engine, check the oil level with the mower on a level surface:

- a. Wipe the dipstick clean.
- b. Insert and remove the dipstick without screwing it into the filler neck. Check the oil level shown on the dipstick.
- c. If the oil level is low, add oil to reach the upper limit mark on the dipstick. Do not overfill. If the engine is overfilled, the excess oil may get transferred to the air cleaner housing and air cleaner filter.

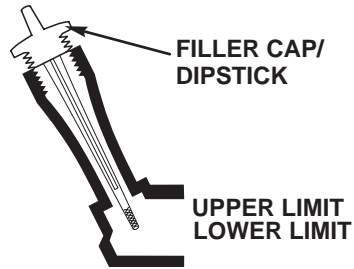
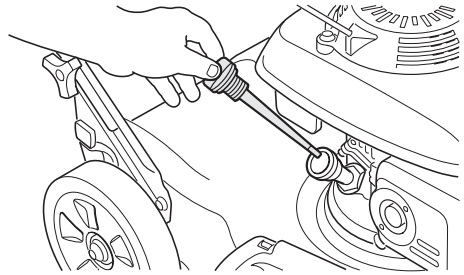

## NOTICE

Running the engine with a low oil level can cause engine damage.

- d. Screw in the filler cap/dipstick securely.

## Engine Oil Recommendations

Oil is a major factor affecting performance and service life. Use 4-stroke automotive detergent oil.

SAE 10W-30 is recommended for general use. Other viscosities shown in the chart may be used when the average temperature in your area is within the recommended range.

The SAE oil viscosity and service classification are in the API label on the oil container. Honda recommends that you use API SERVICE category SH or SJ oil with the ILSAC API certification mark displayed on the container.

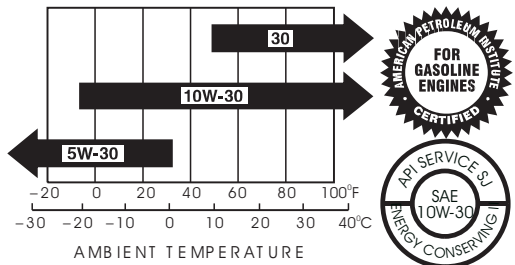

## Air Cleaner Service

A dirty air filter restricts air flow to the carburetor, reducing engine performance. If you operate the mower in very dusty areas, clean the air filter more often than specified in the MAINTENANCE SCHEDULE.

### NOTICE

Operating the engine without an air filter, or with a damaged filter, will allow dirt to enter the engine, causing rapid engine wear. This type of damage is not covered by the Distributor's Limited Warranty.

1. Press down on the cover tabs, then remove the cover. Remove the filter and inspect it; if damaged, replace the filter.

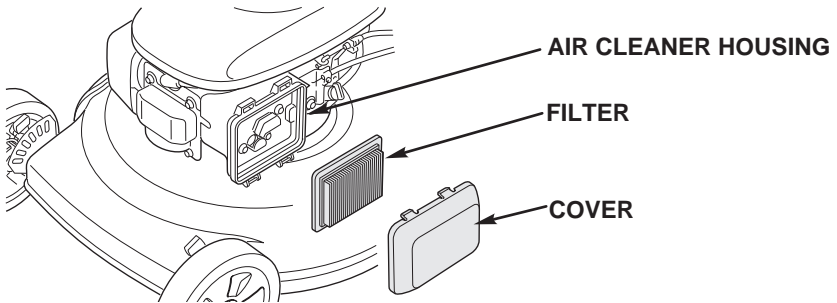

2. Clean the filter by tapping the filter several times on a hard surface to remove dirt, or blowing compressed air (not exceeding 30 psi [207 kPa]) through the filter from the inside. Never try to brush off dirt; brushing will force dirt into the fibers.
3. Wipe dirt from the inside of the air cleaner housing and cover, using a moist rag. Be careful to prevent dirt from entering the air duct that leads to the carburetor. Reinstall the filter and cover.

## Flywheel Brake Lever Operation Inspection.

Start the engine outdoors and move the throttle to FAST. Release the flywheel brake lever; the engine should stop quickly. If it does not, take your mower to an authorized Honda servicing dealer for repair.

# MAINTENANCE

## Spark Plug Service

Refer to page 46 for replacement spark plug numbers.

### NOTICE

An incorrect spark plug can cause engine damage.

For good performance, the spark plug must be properly gapped and free of deposits.

1. Disconnect the spark plug cap and remove dirt from the area. Use a spark plug wrench to remove the spark plug.
2. Inspect the plug; replace it if the electrodes are worn, or if the insulator is cracked or chipped. Clean plug completely if you are going to reuse it.
3. Set the gap to 0.028 ~ 0.031 in (0.7 ~ 0.8 mm).
4. After the plug seats, tighten it as follows to seat the washer:

**Old plug:** / to / turn

**New plug:** / turn

SPARK PLUG

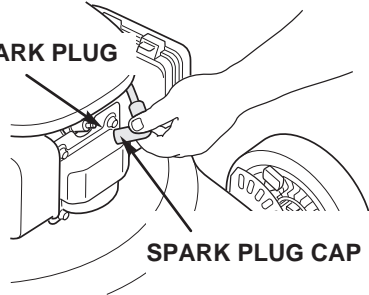

SPARK PLUG CAP

SPARK PLUG WRENCH

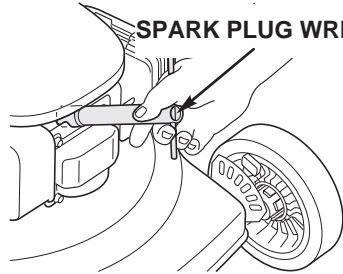

0.028 ~ 0.031 in  
(0.7 ~ 0.8 mm)

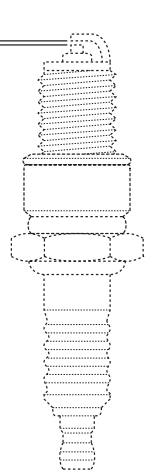

### NOTICE

A loose spark plug can overheat and damage the engine. Overtightening the spark plug can damage the threads in the cylinder head.

7. Install the spark plug cap on the spark plug.

## Carburetor Modification for High Altitude Operation

At high altitude, the standard carburetor air-fuel mixture will be too rich. Performance will decrease, and fuel consumption will increase. A very rich mixture will also foul the spark plug and cause hard starting. High altitude performance can be improved by specific modifications to the carburetor. If you always operate your mower at altitudes above 5,000 feet (1,524 meters) have an authorized Honda servicing dealer perform this carburetor modification. Even with carburetor modification, engine horsepower will decrease about 3.5% for each 1,000 foot (300-meter) increase in altitude. The effect of altitude on horsepower will be greater than this if no carburetor modification is made.

### NOTICE

When the carburetor has been modified for high altitude operation, the air-fuel mixture will be too lean for low altitude use. Operation at altitudes below 5,000 feet (1,524 meters) with a modified carburetor may cause the engine to overheat and result in serious engine damage. For use at low altitudes, have an authorized Honda servicing dealer return the carburetor to original factory specifications.

## Fuel Recommendations

Use unleaded gasoline with a pump octane rating of 86 or higher. This engine is certified to operate on unleaded gasoline. Unleaded gasoline produces fewer engine and spark plug deposits and extends exhaust system life. Never use stale or contaminated gasoline or an oil/gasoline mixture. Avoid getting dirt or water in the fuel tank. Occasionally you may hear light “spark knock” or “pinging” (metallic rapping noise) while operating under heavy loads. This is no cause for concern. If spark knock or pinging occurs at a steady engine speed, under normal load, change brands of gasoline. If spark knock or pinging persists, see an authorized Honda servicing dealer.

### NOTICE

Running the engine with persistent spark knock or pinging can cause engine damage. Running the engine with persistent spark knock or pinging is misuse, and the Distributor's Limited Warranty does not cover parts damaged by misuse. For oxygenated fuel information refer to page 56.

# MAINTENANCE

---

## BLADE REMOVAL AND INSTALLATION

If you remove the blade, use a torque wrench for installation. Wear heavy gloves to protect your hands. To avoid weakening the blade, or causing imbalance or poor cutting, the blade should be sharpened by trained staff at an authorized Honda servicing dealer. If replacing the blade, use a genuine Honda replacement blade or equivalent.

- 1. Removal:** Turn the fuel valve to OFF. Disconnect the spark plug cap, then tilt the mower to the right side, carburetor side up.
2. Remove the two blade bolts with a 14 mm socket. Use a wooden block to prevent the blade from turning when removing the bolts. Remove the blade from the blade holder.
- 3. Installation:** Clean around the blade holder. Install the blade using the bolts and special washers exactly (concave side of the special washers toward the blade) as shown.

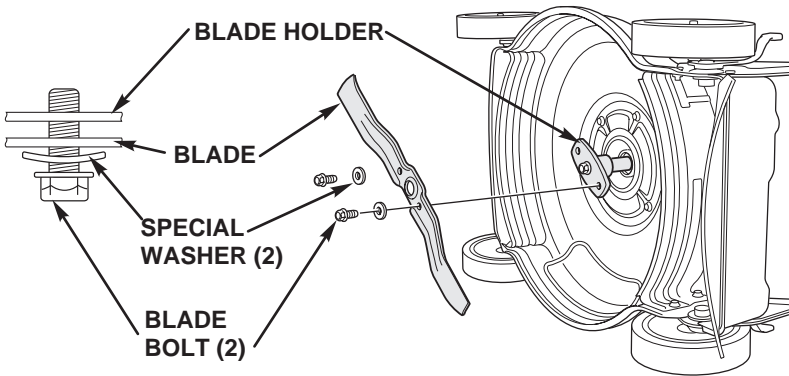

The blade bolts and washers are specially designed; when replacing them, use only genuine Honda parts. Tighten the bolts with a torque wrench. Use a wooden block to stop the blade from turning.

**Blade bolt torque: 36 ~ 43 ft-lb (49 ~ 59·N)**

If you don't have a torque wrench, have an authorized Honda servicing dealer tighten the blade bolts before you use the mower. If the blade bolts are overtightened, they could break. If the blade bolts are not tightened enough, they could loosen or come out. In either case, it would be possible for the blade to fly off while you are operating the mower.



# TROUBLESHOOTING

## ENGINE PROBLEMS

<b>Engine Will Not Start</b>	<b>Possible Cause</b>	<b>Correction</b>
1. Check control positions.	Fuel valve OFF.	Turn fuel valve ON (p. 9).
	Throttle lever in wrong position.	Move throttle lever to CHOKE position, unless the engine is warm (p. 17).
2. Check fuel.	Out of fuel.	Refuel (p. 14).
	Bad fuel; mower stored without treating or draining gasoline, or refueled with bad gasoline.	Drain fuel tank and carburetor (p. 43). Refuel with fresh gasoline (p. 14).
3. Remove and inspect spark plug.	Spark plug faulty, fouled, or improperly gapped.	Clean, gap, or replace spark plug (p. 36).
	Spark plug wet with fuel (flooded engine).	Dry and reinstall spark plug. Start engine with throttle lever in FAST position.
4. Take mower to an authorized Honda servicing dealer, or refer to shop manual.	Fuel filter clogged, carburetor malfunction, ignition malfunction, valves stuck, etc.	Replace or repair faulty components as necessary.

<b>Loss of Power</b>	<b>Possible Cause</b>	<b>Correction</b>
1. Check throttle position.	Throttle not set to FAST.	Move throttle to FAST (p. 19).
2. Check grass height.	Grass too tall to cut.	Raise cutting height (p. ), cut narrower swath (p. ), or cut more frequently.
3. Check under mower deck.	Mower deck clogged.	Clean out mower deck (p. 25).
4. Check air filter.	Air filter clogged.	Clean or replace air filter (p. 35).
5. Check fuel.	Bad fuel; mower stored without treating or draining gasoline, or refueled with bad gasoline.	Drain fuel tank and carburetor (p. 43). Refuel with fresh gasoline (p. 14).
6. Take mower to an authorized Honda servicing dealer, or refer to shop manual.	Fuel filter clogged, carburetor malfunction, ignition malfunction, valves stuck, etc.	Replace or repair faulty components as necessary.

# TROUBLESHOOTING

## VIBRATION PROBLEMS

<b>Excessive Vibration</b>	<b>Possible Cause</b>	<b>Correction</b>
1. Check mower deck and blade.	Grass and debris lodged under mower deck.	Clean out mower deck (p. 25).
	Blade loose, bent, damaged, or unbalanced by improper sharpening.	Tighten loose blade bolts. Replace damaged blade (p. -).
2. Take mower to an authorized Honda servicing dealer for repair.	Mechanical damage, such as a bent crankshaft.	Replace or repair faulty components as necessary.

## MOWING AND BAGGING PROBLEMS

<b>Poor Cut Quality or Poor Mowing/Bagging Performance</b>	<b>Possible Cause</b>	<b>Correction</b>
1. Check that the throttle lever is in the FAST position.	Engine speed is too slow to cut well.	Move throttle lever to the FAST position (p. 19).
2. Reduce forward speed.	Mower is moving too fast for lawn conditions.	Release the drive clutch lever (SD) and push slower (SD & PD).
3. Check cutting height adjustment levers.	Adjustment levers set at different positions.	Set all levers at the same cutting height position (p. ).
4. Check grass bag (if equipped).	Grass bag overfilled or clogged.	Empty the grass bag. Wash the grass bag if clogged with dirt.
5. Check mower deck and blade.	Mower deck clogged.	Clear out the mower deck (p. 25).
	Blade dull, worn, or damaged.	Sharpen or replace blade if necessary (p. ).
	Wrong blade installed.	Install correct blade (p. ).

# STORAGE

## STORAGE PREPARATION

Proper storage preparation is essential for keeping your lawn mower troublefree and looking good. The following steps will help to keep rust and corrosion from impairing your lawn mower's function and appearance, and will make the engine easier to start when you use the lawn mower again.

### Cleaning

1. Wash the lawn mower, including the underside of the mower deck.

#### Engine

Wash the engine by hand, and be careful to prevent water from entering the air cleaner.

#### NOTICE

- Using a garden hose or pressure washing equipment can force water into the air cleaner. Water in the air cleaner will soak the filters and can enter the carburetor or engine, causing damage.
- Water on a hot engine can cause damage. If the engine has been running, allow it to cool for at least 1/2 hour before washing.

#### Mower Deck

If using a garden hose or pressure washing equipment to clean the mower deck, be careful to avoid getting water into controls and cables, or anywhere near the engine air cleaner or muffler opening.

Before washing the underside of the mower deck, be sure the fuel valve is in the OFF position. Disconnect the spark plug cap. Rest the mower on its right side, so the carburetor side is up. This will help to prevent fuel leakage and hard starting due to carburetor flooding. Wear heavy gloves to protect your hands from the blade.

2. After washing the lawn mower, wipe dry all accessible surfaces.
3. With the mower in an upright position, start the engine outdoors, and let it run until it reaches normal operating temperature to evaporate any water remaining on the engine.
4. Stop the engine and allow it to cool.
5. After the lawn mower is clean and dry, touch up any damaged paint, and coat other areas that may rust with a light film of oil. Lubricate the control cable cores with a silicone spray lubricant.

# STORAGE

---

## Fuel

Gasoline will oxidize and deteriorate in storage. Old gasoline will cause hard starting, and it leaves gum deposits that clog the fuel system. If the gasoline in your mower deteriorates during storage, you may need to have the carburetor and other fuel system components, serviced or replaced.

The length of time that gasoline can be left in your fuel tank and carburetor without causing functional problems will vary with such factors as gasoline blend, your storage temperatures, and whether the fuel tank is partially or completely filled. The air in a partially filled fuel tank promotes fuel deterioration. Very warm storage temperatures accelerate fuel deterioration. Fuel deterioration problems may occur within a few months, or even less if the gasoline was not fresh when you filled the fuel tank.

The Distributor's Limited Warranty does not cover fuel system damage or engine performance problems resulting from neglected storage preparation.

You can extend fuel storage life by adding a gasoline stabilizer that is formulated for that purpose, or you can avoid fuel deterioration problems by draining the fuel tank and carburetor.

### Adding fuel stabilizer to extend fuel storage life

When adding a fuel stabilizer, fill the fuel tank with fresh gasoline. If only partially filled, air in the tank will promote fuel deterioration during storage. If you keep a container of gasoline for refueling, be sure that it contains only fresh gasoline.

1. Add fuel stabilizer following the manufacturer's instructions.
2. After adding a fuel stabilizer, run the engine outdoors for 10 minutes to be sure that treated gasoline has replaced the untreated gasoline in the carburetor.
3. Stop the engine, and turn the fuel valve to the OFF position. This turns off the fuel flow between the fuel tank and the carburetor.

## Draining the Fuel Tank and Carburetor

1. Remove the carburetor drain bolt with a 10 mm wrench, and drain the carburetor bowl fuel into an approved container.

### ⚠ WARNING

Gasoline is highly flammable and explosive.

You can be burned or seriously injured when handling fuel.

- Stop the engine and keep heat, sparks, and flame away.
- Handle fuel only outdoors.

2. Turn the fuel valve ON (see page 9). This will allow fuel in the fuel tank to drain through the carburetor bowl. After the fuel is completely drained, reinstall the drain bolt.

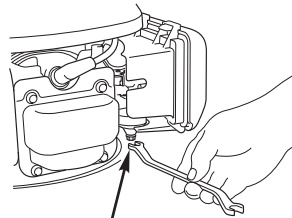

DRAIN BOLT

## Engine Oil

Change the engine oil (see page 33).

## Engine Cylinder

Remove the spark plug (see page ). Pour a tablespoon (5 ~ 10 cc) of clean engine oil into the cylinder. Pull the starter rope several times to distribute the oil in the cylinder. Reinstall the spark plug. Pull the starter rope slowly until resistance is felt then return the starter grip gently. This closes the valves so moisture cannot enter.

## Handlebar Folding

Remove the grass bag (if installed). Loosen the handlebar locking knobs. Press the handlebar struts to release the locating pins, then swing the handlebar forward. Don't allow the cables to be bent or pinched.

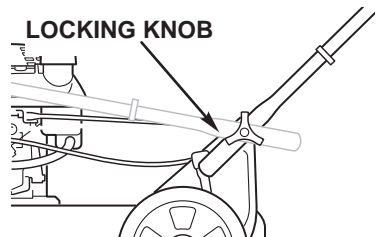

# STORAGE

---

## STORAGE PRECAUTIONS

If your mower will be stored with gasoline in the fuel tank and carburetor, it is important to reduce the hazard of gasoline vapor ignition. Select a well-ventilated storage area away from any appliance that operates with a flame, such as a furnace, water heater, or clothes dryer. Also avoid any area with a spark-producing electric motor, or where power tools are operated.

If possible, avoid storage areas with high humidity, because that promotes rust and corrosion.

Unless all fuel has been drained from the fuel tank, turn the fuel valve to OFF to reduce the possibility of fuel leakage.

Place the mower with its wheels on a level surface. Tilting can cause fuel or oil leakage.

The handlebar can be folded for compact storage (see page 43).

With the engine and exhaust system cool, cover the mower to keep out dust. A hot engine and exhaust system can ignite or melt some materials. Do not use sheet plastic as a dust cover. A nonporous cover will trap moisture around the mower, promoting rust and corrosion.

## REMOVAL FROM STORAGE

Check your mower as described in the BEFORE OPERATION chapter of this manual.

If the fuel was drained during storage preparation, fill the tank with fresh gasoline. If you keep a container of gasoline for refueling, be sure that it contains only fresh gasoline. Gasoline oxidizes and deteriorates over time, causing hard starting.

If the cylinder was coated with oil during storage preparation, the engine will smoke briefly at startup. This is normal.

# SPECIFICATIONS

## MOWER MODELS

HRS216PDA: Manually propelled  
HRS216SDA: Self-propelled

## DIMENSIONS, WEIGHTS, AND CAPACITIES

Length	57-1/4 in (1455 mm)
Width (at mower deck)	23 in (582 mm)
Overall Height (with cutting height set at 2-1/2 in [64 mm])	38-7/8 in (987 mm)
Dry Weight	PD: 62.2 lb (28.8 kg) SD: 69.4 lb (31.5kg)
Cutting Width	21 in (530 mm)
Approximate Cutting Height (adjustable)	1 in (25 mm), 1-1/2 in (37 mm), 2 in (50 mm), 2-1/2 in (66 mm), 3 in (75 mm), 3-1/2 in (87 mm)
Fuel Tank Capacity	0.29 US gal (1.1 ℓ)
Engine Oil Capacity	0.58 US qt (0.55 ℓ)

## ENGINE DESIGN AND PERFORMANCE

Engine Model	GCV160
Engine Type	4-stroke, overhead-cam, single-cylinder, air-cooled
Displacement	9.8 cu in (160 cc)
Bore and Stroke	2.52 x 1.97 in (64 x 50 mm)
Compression Ratio	8.5:1
Ignition System	Transistorized magneto
Maximum Horsepower	5.5 bhp (4.1 kW) at 3,600 rpm
Maximum Torque	8.1 ft-lb (11.0 N·m) at 2,500 rpm

## TRANSMISSION DESIGN AND PERFORMANCE (SD)

Transmission Type	single speed
Ground Speed	2.8 mph (4.5 km/h)

# SPECIFICATIONS

---

## MAINTENANCE

Fuel	Unleaded gasoline with a pump octane rating of 86 or higher	See page 37.
Engine Oil	SAE 10W-30, API SH or SJ	See page 34.
Transmission lubricant (SD)	Grease (NLGI #2)	See shop manual.
Spark Plug Type  (Resistor plugs reduce interference with radio and television reception.)	<b>Regular:</b> NGK – BP6ES DENSO – W20EP-U <b>Resistor:</b> NGK - BPR6ES DENSO - W20EPS-U	See page 36.
Maximum Governed Speed	3,100 +0/-150 rpm	See shop manual.
Throttle Cable	Adjust for proper choke operation and maximum governed speed.	See shop manual.

## TUNEUP

Spark Plug Gap	0.028 ~ 0.031 in (0.7 ~ 0.8 mm)	See page 36.
Idle Speed	1,700 ± 150 rpm	See page .
Valve Clearance (cold)	Intake: 0.15 ± 0.02 mm Exhaust: 0.20 ± 0.02 mm	See shop manual.
Other Specifications	No other adjustments needed.	



# ASSEMBLY

## Unpacking

Remove all the protective cardboard from the mower, including the piece around the handlebar.

## Handlebar Setup

Loosen the two knobs on the lower section of the handlebar enough so you can raise the handlebar into the mowing position. Once the handlebar is in place, tighten the knobs securely.

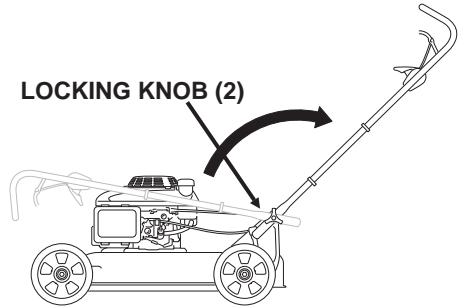

## Install Starter Rope

Disconnect the spark plug cap. Pull the flywheel brake lever back, then pull the starter grip toward the starter rope loop. Release the lever, then press the rope into the loop. Connect the spark plug cap.

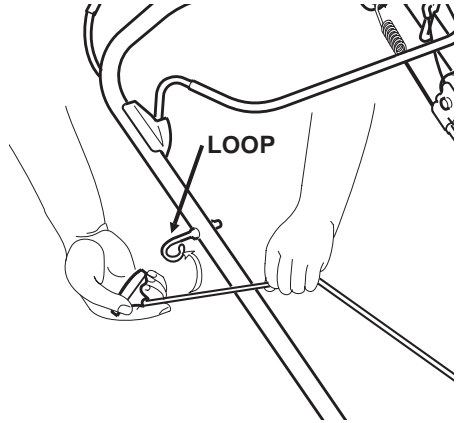

## Add Oil

The mower is shipped WITHOUT OIL in the engine. Refer to page 34 for what kind of oil to use, and how to correctly add oil to the engine.

## Add Fuel

See page 14 for instructions on how to add fuel.

## Before Use...

All operators of the mower must read the MOWER SAFETY, CONTROLS, and BEFORE OPERATION chapters (starting on page 4) before using the mower.

# ADDITIONAL INFORMATION

## WARRANTY

### Distributor's Limited Warranty

PRODUCTS COVERED BY THIS WARRANTY:	LENGTH OF WARRANTY: (from date of original retail purchase)	
	Noncommercial/Nonrental	Commercial/Rental
Harmony II Lawn Mowers	24 months	3 months

#### To Qualify for this Warranty:

The product must be purchased in the United States, Puerto Rico, or the U.S. Virgin Islands from American Honda or a dealer authorized by American Honda to sell those products. This warranty applies to the first retail purchaser and each subsequent owner during the applicable warranty time period.

#### What American Honda will Repair or Replace Under Warranty:

American Honda will repair or replace, at its option, any part that is proven to be defective in material or workmanship under normal use during the applicable warranty time period. Warranty repairs and replacements will be made without charge for parts or labor. Anything replaced under warranty becomes the property of American Honda Motor Company, Inc. All parts replaced under warranty will be considered as part of the original product and any warranty on those parts will expire coincident with the original product warranty.

#### To Obtain Warranty Service:

You must take the Honda Harmony lawn mower, riding mower, or lawn tractor and proof of original retail purchase date, at your expense, to any Honda Power Equipment dealer in the United States, Puerto Rico, or the U.S. Virgin Islands who is authorized to service that product, during the dealer's normal business hours. If you are unable to obtain warranty service, or are dissatisfied with the warranty service you receive, take the following steps: First, contact the owner of the dealership involved; normally this should resolve the problem. However, if you should require further assistance, write or call the Power Equipment Customer Relations Department of American Honda Motor Co., Inc. Refer to page for contact information.

## ADDITIONAL INFORMATION

---

### Exclusions:

THIS WARRANTY DOES NOT EXTEND TO PARTS AFFECTED OR DAMAGED BY ACCIDENT AND/OR COLLISION, NORMAL WEAR, FUEL CONTAMINATION, USE IN AN APPLICATION FOR WHICH THE PRODUCT WAS NOT DESIGNED OR ANY OTHER MISUSE, NEGLIGENCE, INCORPORATION OR USE OF UNSUITABLE ATTACHMENTS OR PARTS, UNAUTHORIZED ALTERATION, OR ANY CAUSES OTHER THAN DEFECTS IN MATERIAL OR WORKMANSHIP OF THE PRODUCT.

MOWER BLADES AND MOWER DECK HOUSINGS, ARE SPECIFICALLY NOT WARRANTED AGAINST DAMAGE, INCLUDING BUT NOT LIMITED TO, ABRASIVE DAMAGE.

### **Disclaimer of Consequential Damage and Limitation of Implied Warranties:**

AMERICAN HONDA DISCLAIMS ANY RESPONSIBILITY FOR LOSS OF TIME OR USE OF THE PRODUCT, TRANSPORTATION, COMMERCIAL LOSS, OR ANY OTHER INCIDENTAL OR CONSEQUENTIAL DAMAGE. ANY IMPLIED WARRANTIES ARE LIMITED TO THE DURATION OF THIS WRITTEN LIMITED WARRANTY. Some states do not allow limitations on how long an implied warranty lasts and/or do not allow the exclusion or limitation of incidental or consequential damages, so the above exclusions and limitations may not apply to you.

This warranty gives you specific legal rights, and you may also have other rights which vary from state to state.

# ADDITIONAL INFORMATION

---

## Accessories, Replacement Parts, and Apparel Warranty

PRODUCTS COVERED BY THIS WARRANTY:	LENGTH OF WARRANTY (from date of original retail purchase)	
	Noncommercial / Nonrental	Commercial / Rental
Accessories	12 months	3 months
Replacement Parts	6 months	3 months
Apparel	6 months	3 months

### ***To Qualify for this Warranty:***

The accessories, replacement parts, or apparel must be purchased in the United States, Puerto Rico, or the U.S. Virgin Islands from American Honda or a dealer authorized by American Honda to sell those products.

You must be the first retail purchaser. This warranty is not transferable to subsequent owners.

### **What American Honda will Repair or Replace Under Warranty:**

American Honda will repair or replace, at its option, any power equipment accessories, replacement parts, or apparel that are proven to be defective in material or workmanship under normal use during the applicable warranty time period. Anything replaced under warranty becomes the property of American Honda Motor Company, Inc. All parts replaced under warranty will be considered as part of the original product and any warranty on those parts will expire coincident with the original product warranty.

Accessories and replacement parts, installed by a dealer who is authorized by American Honda to sell them, will be repaired or replaced under warranty without charge for parts or labor. If installed by anyone else, accessories and replacement parts will be repaired or replaced under warranty without charge for parts, but any labor charges will be the responsibility of the purchaser.

Apparel will be repaired or replaced under warranty without any charge.

### ***To Obtain Warranty Service:***

You must take the Honda Power Equipment accessory, replacement part, apparel or the power equipment on which the accessory or replacement part is installed, and proof of purchase, at your expense, to any Honda Power Equipment dealer in the United States, Puerto Rico, or the U.S. Virgin Islands who is authorized to service that product, during the dealer's normal business hours. If you are unable to obtain warranty service, or are dissatisfied with the warranty service you receive, take the following steps: First, contact the owner of the dealership involved; normally this will resolve the problem. However, if you should require further assistance, write or call the Power Equipment Customer Relations Department of American Honda Motor Co., Inc. Refer to page 57 for contact information.

## ADDITIONAL INFORMATION

---

### Exclusions:

THIS WARRANTY DOES NOT EXTEND TO ACCESSORIES, PARTS, OR APPAREL AFFECTED OR DAMAGED BY ACCIDENT AND/OR COLLISION, NORMAL WEAR, USE IN AN APPLICATION FOR WHICH THE PRODUCT WAS NOT DESIGNED OR ANY OTHER MISUSE, NEGLIGENCE, INCORPORATION OR USE OF UNSUITABLE ATTACHMENTS OR PARTS, UNAUTHORIZED ALTERATION, IMPROPER INSTALLATION, OR ANY CAUSES OTHER THAN DEFECTS IN MATERIAL OR WORKMANSHIP OF THE PRODUCT.

MOWER BLADES AND MOWER DECK HOUSINGS, ARE SPECIFICALLY NOT WARRANTED AGAINST DAMAGE, INCLUDING BUT NOT LIMITED TO, ABRASIVE DAMAGE.

### Disclaimer of Consequential Damage and Limitation of Implied Warranties:

AMERICAN HONDA DISCLAIMS ANY RESPONSIBILITY FOR LOSS OF TIME OR USE OF THE PRODUCT, OR THE POWER EQUIPMENT ON WHICH THE PRODUCT IS INSTALLED, TRANSPORTATION, COMMERCIAL LOSS, OR ANY OTHER INCIDENTAL OR CONSEQUENTIAL DAMAGE. ANY IMPLIED WARRANTIES ARE LIMITED TO THE DURATION OF THIS WRITTEN WARRANTY. Some states do not allow limitations on how long an implied warranty lasts and/or do not allow the exclusion or limitation of incidental or consequential damages, so the above exclusions and limitations may not apply to you.

This warranty gives you specific legal rights, and you may also have other rights which vary from state to state.

# ADDITIONAL INFORMATION

---

## Emission Control System Warranty

Your new Honda Power Equipment engine complies with both the U.S. EPA and State of California emission regulations. American Honda provides the same emission warranty coverage for engines sold in all 50 states.

Your Warranty Rights And Obligations:

### California

The California Air Resources Board and American Honda Motor Co., Inc. are pleased to explain the emission control system warranty on your Honda Power Equipment engine. In California, new utility and lawn and garden equipment engines must be designed, built and equipped to meet the State's stringent anti-smog standards.

### Other States

In other areas of the United States your engine must be designed, built, and equipped to meet the U.S. EPA Phase I Emission standard for spark ignited engines at or below 19 kilowatts.

### All States

American Honda Motor Co., Inc. must warrant the emission control system on your power equipment engine for the period of time listed below provided there has been no abuse, neglect or improper maintenance of your power equipment engine. Where a warrantable condition exists, American Honda Motor Co., Inc. will repair your power equipment engine at no cost to you including diagnosis, parts and labor.

Your emission control system may include such parts as the carburetor or fuel injection system, the ignition system, and catalytic converter. Also included may be hoses, connectors and other emission-related assemblies.

### Manufacturer's Warranty Coverage:

The 1995 and later power equipment engines are warranted for two years. If any emission-related part on your engine is defective, the part will be repaired or replaced by American Honda Motor Co., Inc.

### Owner's Warranty Responsibility:

As the power equipment engine owner, you are responsible for the performance of the required maintenance listed in your owner's manual. American Honda Motor Co., Inc. recommends that you retain all receipts covering maintenance on your power equipment engine, but American Honda Motor Co., Inc. cannot deny warranty coverage solely for the lack of receipts or for your failure to ensure the performance of all scheduled maintenance.

As the power equipment engine owner, you should however be aware that American Honda Motor Co., Inc. may deny you warranty coverage if your power equipment engine or a part has failed due to abuse, neglect, improper maintenance, or unapproved modifications.

You are responsible for presenting your power equipment engine to a Honda Power Equipment dealer as soon as a problem exists. The warranty repairs should be completed in a reasonable amount of time, not to exceed 30 days.

If you have any questions regarding your warranty rights and responsibilities, you should write or call the Honda Power Equipment Customer Relations Department. Refer to page for contact information.

## ADDITIONAL INFORMATION

---

### Warranty Coverage:

Honda power equipment engines manufactured after January 1, 1995 and sold in the State of California, and U.S. EPA certified engines manufactured on or after September 1, 1996 and sold in all of the United States, are covered by this warranty for a period of two years from the date of delivery to the original retail purchaser. This warranty is transferable to each subsequent purchaser for the duration of the warranty period.

Warranty repairs will be made without charge for diagnosis, parts or labor. All defective parts replaced under this warranty become the property of American Honda Motor Co., Inc. A list of warranted parts is on the reverse side of this warranty statement. Normal maintenance items, such as spark plugs and filters, that are on the warranted parts list are warranted up to their required replacement interval only.

American Honda Motor Co., Inc. is also liable for damages to other engine components caused by a failure of any warranted part during the warranty period.

Only Honda approved replacement parts may be used in the performance of any warranty repairs and must be provided without charge to the owner. The use of replacement parts not equivalent to the original parts may impair the effectiveness of your engine emission control system. If such a replacement part is used in the repair or maintenance of your engine, and an authorized Honda dealer determines it is defective or causes a failure of a warranted part, your claim for repair of your engine may be denied. If the part in question is not related to the reason your engine requires repair, your claim will not be denied.

### To Obtain Warranty Service:

You must take your Honda Power Equipment engine or the product on which it is installed, along with your warranty registration card or other proof of original purchase date, at your expense, to any Honda Power Equipment dealer who is authorized by American Honda Motor Co., Inc. to sell and service that Honda product during his normal business hours. Claims for repair or adjustment found to be caused solely by defects in material or workmanship will not be denied because the engine was not properly maintained and used.

If you are unable to obtain warranty service, or are dissatisfied with the warranty service you received, contact the owner of the dealership involved. Normally this should resolve your problem. However, if you require further assistance, write or call the Power Equipment Customer Relations Department of American Honda Motor Co., Inc. Refer to page for contact information.

# ADDITIONAL INFORMATION

---

**Exclusions:**

FAILURES OTHER THAN THOSE RESULTING FROM DEFECTS IN MATERIAL OR WORKMANSHIP ARE NOT COVERED BY THIS WARRANTY. THIS WARRANTY DOES NOT EXTEND TO EMISSION CONTROL SYSTEMS OR PARTS WHICH ARE AFFECTED OR DAMAGED BY OWNER ABUSE, NEGLIGENCE, IMPROPER MAINTENANCE, MISUSE, MISFUELING, IMPROPER STORAGE, ACCIDENT AND/OR COLLISION, THE INCORPORATION OF, OR ANY USE OF, ANY ADD-ON OR MODIFIED PARTS, UNSUITABLE ATTACHMENTS, OR THE UNAUTHORIZED ALTERATION OF ANY PART.

THIS WARRANTY DOES NOT COVER REPLACEMENT OF EXPENDABLE MAINTENANCE ITEMS MADE IN CONNECTION WITH REQUIRED MAINTENANCE SERVICES AFTER THE ITEM'S FIRST SCHEDULED REPLACEMENT AS LISTED IN THE MAINTENANCE SECTION OF THE PRODUCT OWNER'S MANUAL, SUCH AS: SPARK PLUGS AND FILTERS.

**Disclaimer of Consequential Damage and Limitation of Implied Warranties:**

AMERICAN HONDA MOTOR CO., INC. DISCLAIMS ANY RESPONSIBILITY FOR INCIDENTAL OR CONSEQUENTIAL DAMAGES SUCH AS LOSS OF TIME OR THE USE OF THE POWER EQUIPMENT, OR ANY COMMERCIAL LOSS DUE TO THE FAILURE OF THE EQUIPMENT; AND ANY IMPLIED WARRANTIES ARE LIMITED TO THE DURATION OF THIS WRITTEN WARRANTY. THIS WARRANTY IS APPLICABLE ONLY WHERE THE CALIFORNIA OR U.S. EPA EMISSION CONTROL SYSTEM WARRANTY REGULATION IS IN EFFECT.

**Emission Control System Warranty Parts:**

<b>SYSTEMS COVERED BY THIS WARRANTY</b>	<b>PARTS DESCRIPTION</b>
Fuel Metering	Carburetor assembly Fuel injection pump Fuel injection nozzle Fuel regulator
Exhaust System	Catalyst
Air Induction	Air filter housing Air filter element* Crankcase breather tube
Ignition	Flywheel magneto Ignition pulse generator Ignition coil assembly Ignition control module Spark plug cap Spark plug*
Miscellaneous Parts	Tubing, fittings, seals, gaskets and clamps associated with these listed systems.

\* Covered up to the first required replacement only. See the *Maintenance Schedule* on page 32.



### Manual en Español

Una versión de este manual en Español esta disponible. Favor de ponerse en contacto con el **departamento de relaciones al cliente** la dirección o teléfono listado abajo.

### Warranty Service Information

Honda Power Equipment dealership personnel are trained professionals. They should be able to answer any question you may have. If you encounter a problem that your dealer does not solve to your satisfaction, please discuss it with the dealership's management. The Service Manager or General Manager can help. Almost all problems are solved in this way.

If you are dissatisfied with the decision made by the dealership's management, contact the Honda Power Equipment Customer Relations Office. You can write:

American Honda Motor Co., Inc.  
Power Equipment Division  
Customer Relations Office  
4475 River Green Parkway  
Duluth, GA 30096-2565

Or telephone:

(770) 497-6400

When you write or call, please give us this information:

- Model and serial numbers (see page )
- Name of the dealer who sold the lawn mower to you
- Name and address of the dealer who services your lawn mower
- Date of purchase
- Your name, address, and telephone number
- A detailed description of the problem

## ADDITIONAL INFORMATION

---

### OXYGENATED FUELS

Some conventional gasolines are being blended with alcohol or an ether compound. These gasolines are collectively referred to as oxygenated fuels. To meet clean air standards, some areas of the USA and Canada use oxygenated fuels to help reduce emissions. If you use an oxygenated fuel, be sure it is unleaded and meets the minimum octane rating requirement. Before using an oxygenated fuel, try to confirm the fuel's contents. Some states/provinces require this information to be posted on the pump.

The following are the EPA approved percentages of oxygenates:

**ETHANOL** ——(ethyl or grain alcohol) 10% by volume  
You may use gasoline containing up to 10% ethanol by volume. Gasoline containing ethanol may be marketed under the name "Gasohol".

**MTBE** ——(Methyl Tertiary Butyl Ether) 15% by volume  
You may use gasoline containing up to 15% MTBE by volume.

**METHANOL** ——(methyl or wood alcohol) 5% by volume  
You may use gasoline containing up to 5% methanol by volume, as long as it also contains cosolvents and corrosion inhibitors to protect the fuel system. Gasoline containing more than 5% methanol by volume may cause starting and/or performance problems. It may also damage metal, rubber, and plastic parts of your fuel system.

If you notice any undesirable operating symptoms, try another service station, or switch to another brand of gasoline. Fuel system damage or performance problems resulting from the use of an oxygenated fuel containing more than the percentages of oxygenates mentioned above are not covered under warranty.

### HONDA PUBLICATIONS

Two other documents are available from your Honda dealer. There is a Shop Manual, which covers complete maintenance and overhaul procedures. It is intended to be used by a skilled technician. There is also a Parts Catalog, that provides a complete, illustrated parts lists.

### SPARK ARRESTER SERVICE (optional equipment)

Your lawn mower engine is not factory-equipped with a spark arrester. In some areas, it is illegal to operate an engine without a spark arrester. Check local laws and regulations. An optional USDA approved spark arrester is available from an authorized Honda servicing dealer.

The spark arrester must be serviced every 100 hours to keep it functioning as designed.

1. Allow the engine to cool, then remove the bolts from the muffler shield. Remove the muffler shield.
2. Loosen the two set screws and remove the spark arrester.
3. Check for carbon deposits on the spark arrester and the exhaust port. Brush carbon deposits away. Be careful to avoid damaging the spark arrester screen.
4. Installation is the reverse of removal. Tighten all hardware securely.

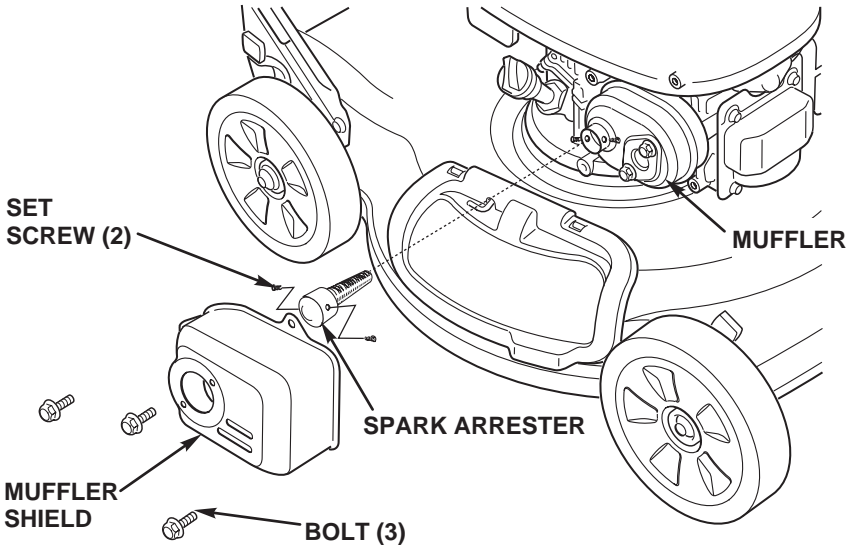

# INDEX

## A

Air Cleaner Inspection.....	15
Air Cleaner Service.....	35
Assembly.....	47

## B

Blade:	
Inspection.....	12
Installation.....	38
Removal.....	38

## C

Carburetor:	
High Altitude Operation.....	37
Choke.....	9 & 17
Clogged Mower Deck.....	25
Clothing Recommendations.....	11
Component Identification.....	7
Contents.....	3
Cutting Height:	
Adjustment Levers.....	10
Recommendations.....	24
Cutting Width Recommendations.....	24

## D

Description of Controls.....	9
Distributor's Limited Warranty.....	48
Drive Clutch Lever (SD):	
Operation.....	10 & 20

## E

Emission System Information.....	32
Emission System Warranty.....	52
Engine:	
Fuel Recommendations.....	37
Maintenance.....	33
Oil Change.....	33
Oil Level.....	13
Oil Recommendations.....	34
Refueling.....	14
Serial Number.....	8
Specifications.....	71
Starting.....	17

Stopping.....	21
Troubleshooting.....	59

## F

Fallen Leaves, Bagging.....	25
Flywheel Brake Lever:	
Operation.....	10 & 19
Frame Serial Number.....	8
Fuel:	
Additive to Extend Storage Life.....	42
Gasoline Recommendations.....	37
Draining.....	43
Refueling.....	14
Valve.....	9

## G

Gasoline Recommendations.....	37
-------------------------------	----

## H

Handlebar Folding.....	43
High Altitude Operation.....	37

## I

Inspection Before Mowing:	
Lawn.....	11
Mower.....	12

## L

Lawn:	
Inspection Before Mowing.....	11
Mowing Tips.....	24
Safe Mowing Practices.....	22
Leaves, Bagging.....	25

## M

Maintenance:	
Blade Removal and	
Installation.....	38
Engine.....	33
Importance.....	28
Safety.....	29
Schedule.....	32
Specifications.....	46

Mower Deck Clogging .....25

Mowing:

- Around Obstacles, Gravel, Objects .....23
- Dry & Wet Grass .....25
- Fallen Leaves .....25
- Patterns .....26
- Slopes .....22
- Tips .....24
- When to Mow .....24

## O

Oil (for engine):

- Change .....33
- Level Check .....13
- Recommendations .....34

Operating the Controls for Mowing .....19

## P

Pre-Operation Check:

- Lawn .....11
- Mower .....12
- Publications .....56

## S

Safety:

- Important Message to Parents ..... 5
- Safe Mowing Practices .....22
- Important Safety Information .....4
- Safety Label Locations .....6
- Safety Message Definitions .....2

Serial Numbers .....8

Spark Arrester Service (optional equipment) .....57

Spark Plug Recommendations & Service .....36

Specifications:

- Capacities .....45
- Dimensions .....45
- Engine Design and Performance .....45
- Maintenance .....46

Transmission Design and Performance .....45

- Tuneup .....46
- Weights .....45

Starting the Engine .....17

Stopping the Engine .....21

Storage:

- Placing in Storage .....44
- Preparation .....41
- Removing From Storage .....44

## T

Throttle Lever:

- Operation .....9 & 19

Transmission (SD):

- Drive Clutch Lever Operation .....10 & 20
- Transporting .....37

Troubleshooting:

- Engine Problems .....39
- Mowing and Bagging Problems .....40
- Vibration Problems .....40

Tuneup Specifications .....46

## W

Warranty:

- Accessories, Replacement Parts, and Apparel .....50
- Distributor's Limited .....48
- Emission Control System .....52
- Service Information .....55

Washing the Mower .....41

## QUICK REFERENCE INFORMATION

Fuel	type	Unleaded gasoline with pump octane rating of 86 or higher (pg. 37).
	capacity	0.29 US gallons (1.1 liters)
Engine Oil	type	SAE 10W-30, API SH or SJ (pg. 34)
	capacity	0.58 US quarts (0.55 liters)
Spark Plug	type	Regular: NGK- BPR6ES DENSO- W20EP-U  Resistor: NGK- BPR6ES DENSO- W20EPS-U
	gap	0.028 ~ 0.031 in (0.7 ~ 0.8 mm) (pg. 36)
Blade Bolts	torque	36~43ft-lb(5.0~6.0kg-m, 49~59Nm) (pg.38)
Carburetor	idle speed	1,700±150 rpm (see shop manual)
Maintenance	before each use	Check blade(s) and bolt tightness (pgs. 12 & 38) Check engine oil level (pg. 34). Check air cleaner (pg. 15).
	first 5 hours	Change engine oil (pg. 33)
	subsequent	Refer to maintenance schedule on pg. 32.

# HONDA

31VG3601  
00X31-VG3-6010



Printed on  
Recycled Paper



CPI 200009710

PRINTED IN U.S.A.