

HONDA

Power

Equipment

Owner's Manual

Rotary Mower

HRR216VXA



See page 44 for instructions on setting up your Lawn Mower.



WARNING:



The engine exhaust from this product contains chemicals known to the State of California to cause cancer, birth defects or other reproductive harm.

Keep this owner's manual handy, so you can refer to it at any time. This owner's manual is considered a permanent part of the lawn mower and should remain with the lawn mower if resold.

The information and specifications included in this publication were in effect at the time of approval for printing. American Honda Motor Co., Inc. reserves the right, however, to discontinue or change specifications or design at any time without notice and without incurring any obligation whatever. No part of this publication may be reproduced without written permission.

INTRODUCTION

Congratulations on your selection of a Honda lawn mower! We are certain you will be pleased with your purchase of one of the finest lawn mowers on the market.

We want to help you get the best results from your new lawn mower and to operate it safely. This manual contains the information on how to do that; please read it carefully.

As you read this manual, you will find information preceded by a **NOTICE** symbol. That information is intended to help you avoid damage to your lawn mower, other property, or the environment.

We suggest you read the *Distributor's Limited Warranty* (page 57) and the *Emission Control System Warranty* (page 59) to fully understand its coverage and your responsibilities of ownership.

When your lawn mower needs scheduled maintenance, keep in mind that your Honda servicing dealer is specially trained in servicing Honda lawn mowers. Your Honda servicing dealer is dedicated to your satisfaction and will be pleased to answer your questions and concerns.

Best Wishes,
American Honda Motor Co., Inc.
Power Equipment Division

INTRODUCTION

A FEW WORDS ABOUT SAFETY

Your safety and the safety of others is very important, and using this lawn mower safely is an important responsibility.

To help you make informed decisions about safety, we have provided operating procedures and other information on labels and in this manual. This information alerts you to potential hazards that could hurt you or others.

Of course, it is not practical or possible to warn you about all the hazards associated with operating or maintaining a lawn mower. You must use your own good judgment.

You will find important safety information in a variety of forms including:

- **Safety Labels**—on the lawn mower.
- **Safety Messages**—preceded by a safety alert symbol and ⚠ one of three signal words: DANGER, WARNING, or CAUTION.

These signal words mean:

 **DANGER** You WILL be KILLED or SERIOUSLY HURT if you don't follow instructions.

 **WARNING** You CAN be KILLED or SERIOUSLY HURT if you don't follow instructions.

 **CAUTION** You CAN be HURT if you don't follow instructions.

- **Safety Headings**—such as *IMPORTANT SAFETY INFORMATION*
- **Safety Section**—such as *LAWN MOWER SAFETY*
- **Instructions**—how to use this lawn mower correctly and safely

This entire book is filled with important safety information—please read it carefully.

CONTENTS

LAWN MOWER SAFETY	4
IMPORTANT SAFETY INFORMATION	4
IMPORTANT MESSAGE TO PARENTS	5
SAFETY LABEL LOCATIONS	6
CONTROLS & FEATURES	7
COMPONENT & CONTROL LOCATIONS	7
DESCRIPTION OF CONTROLS	8
BEFORE OPERATION	11
ARE YOU READY TO GET STARTED?	11
IS YOUR LAWN MOWER READY TO GO?	11
CHECK YOUR WORK AREA	12
GET THE LAWN MOWER READY	13
OPERATION	15
MOWING PRECAUTIONS	15
STARTING THE ENGINE	15
OPERATING THE CONTROLS FOR MOWING	16
STOPPING THE ENGINE	17
SAFE MOWING PRACTICES	17
MOWING TIPS	19
SERVICING YOUR MOWER	22
THE IMPORTANCE OF PROPER MAINTENANCE	22
MAINTENANCE SAFETY	23
MAINTENANCE SCHEDULE	24
BLADES	25
GRASS BAG CLEANING AND REPLACEMENT	28
ENGINE MAINTENANCE	29
CONTROL CABLE ADJUSTMENTS	34
FUEL SYSTEM	35
STORAGE	37
PREPARING FOR STORAGE	37
PLACING IN STORAGE	40
REMOVING FROM STORAGE	40
TRANSPORTING	41
BEFORE LOADING	41
LOADING AND UNLOADING	41
TAKING CARE OF UNEXPECTED PROBLEMS	42
ENGINE WILL NOT START	42
LOSS OF POWER	42
VIBRATION PROBLEMS	43
MOWING AND BAGGING PROBLEMS	43
SET-UP	44
ASSEMBLY	44
ENGINE OIL	46
BEFORE OPERATION	46
TECHNICAL & CONSUMER INFORMATION	47
TECHNICAL INFORMATION	47
EMISSION CONTROL SYSTEM	50
SPECIFICATIONS	53
CONSUMER INFORMATION	55
INDEX	63
QUICK REFERENCE INFORMATION	inside back cover

LAWN MOWER SAFETY

IMPORTANT SAFETY INFORMATION

Most accidents with walk-behind mowers can be prevented if you follow all instructions in this manual and on the mower. The most common hazards, according to accident statistics, are discussed below, along with the best way to protect yourself and others.

Avoid Rotating Blades

Rotating blades can cause serious cuts and even amputate fingers, hands, toes, or feet. Keep away from the mower deck whenever the engine is running. If you need to adjust the cutting height, or work around the deck for any other reason, always shut off the engine. Wear heavy gloves and disconnect the spark plug cap when you need to clean the mower deck or handle the blade.

Clear Mowing Area

Mower blades can throw rocks and other objects with enough force to cause serious injury. Before mowing, carefully inspect the area and remove all sticks, stones, pieces of wire, and other loose objects. Never operate the blade over gravel.

Keep Shields in Place

Guards and shields are designed to protect you from being hit by thrown objects and from hot engine parts and moving components. For your safety and the safety of others, keep all shields in place when the engine is running.

Refuel with Care

Gasoline is extremely flammable and gasoline vapor can explode. Refuel only outdoors, in a well-ventilated area, with the engine OFF. Never smoke near gasoline, and keep other flames and sparks away. Always store gasoline in an approved container.

Wear Protective Clothing

Wearing protective clothing will reduce your risk of injury. Long pants and eye protection reduce the risk of injuries from thrown objects. Sturdy shoes with aggressive soles will help protect your feet and give you better traction on slopes or uneven ground.

Turn Engine Off When Not Mowing

If you need to leave the mower for any reason, even just to inspect the lawn ahead, always turn the engine OFF.

IMPORTANT MESSAGE TO PARENTS

YOUR CHILDREN'S SAFETY IS VERY IMPORTANT to Honda. That's why we urge you to read this message before letting your child operate this lawn mower. Lawn mowers are tools, not toys. As with any equipment, bad judgments can result in serious injuries. You can help prevent accidents by making good decisions about if, when, and how your child operates this equipment.

The first question you'll need to ask is whether your child is capable of operating this mower safely. Remember, young people vary widely, and **AGE IS NOT THE ONLY FACTOR**.

Physically, a child must be **LARGE ENOUGH AND STRONG ENOUGH** to easily start the mower and control its direction. The child also needs enough size, strength, and coordination to comfortably reach and operate the controls.

Another, tougher question you need to ask is if your child has enough **MATURITY AND RESPONSIBILITY** to safely operate this mower. Does the young person think through problems and come to logical solutions? Be honest! Anyone who takes unnecessary risks and doesn't obey rules should not operate this lawn mower.

If you decide that your son or daughter can handle the mower safely, **CAREFULLY READ THE OWNER'S MANUAL** with your child. Make sure you both understand all instructions and safety information. Also, be sure your child wears sturdy shoes and other protective clothing when operating or handling the mower.

SUPERVISION is also very important. Walk with your child during the first few minutes of mowing. Even after the child has become confident with the mower, do not let the young person use the mower without good adult supervision. An adult should also be present during refueling and maintenance. In fact, it's up to parents to make sure that the mower is properly maintained and kept in safe operating condition.

By always placing safety first, your child will acquire useful skills and a sense of accomplishment. And you'll both get the best results from your lawn mower.

LAWN MOWER SAFETY

SAFETY LABEL LOCATIONS

The labels shown here contain important safety information. Please read them carefully. These labels are considered permanent parts of your mower. If a label comes off or becomes hard to read, contact an authorized Honda dealer for a replacement.

⚠ CAUTION
UNDER NORMAL USAGE, THIS BAG MATERIAL IS SUBJECT TO DETERIORATION AND WEAR, AND SHOULD BE CHECKED FREQUENTLY FOR BAG REPLACEMENT. THIS BAG CONFORMS TO A.N.S.I. STANDARD B71.1 ANY REPLACEMENT MUST MEET THIS STANDARD.

⚠ WARNING AVOID SERIOUS INJURY OR DEATH. ■ Follow all instructions in Owner's Manual. ■ Go across slopes, not up and down. ■ Do not mow when children or others are around. ■ Look down and behind, before and while moving backwards. ■ Keep safety devices (guards, shields, switches, etc.) in place and working.	⚠ WARNING OBJECTS THROWN BY BLADE CAN CAUSE SERIOUS INJURY. ■ Inspect area and remove debris before mowing. ■ Keep children and others away. ■ Wear eye protection. ■ Do not operate unless bag or chute are installed or guard is in place.
---	--



⚠ CAUTION
HOT MUFFLER CAN BURN YOU.
Stay away if engine has been running.

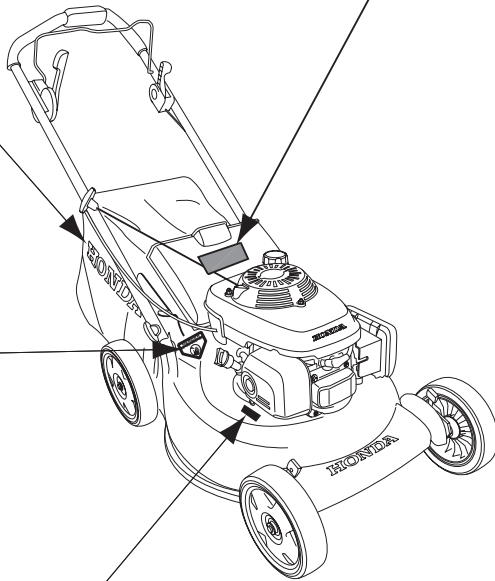

CONTROLS & FEATURES

COMPONENT & CONTROL LOCATIONS

Use this illustration to locate and identify frequently used controls.

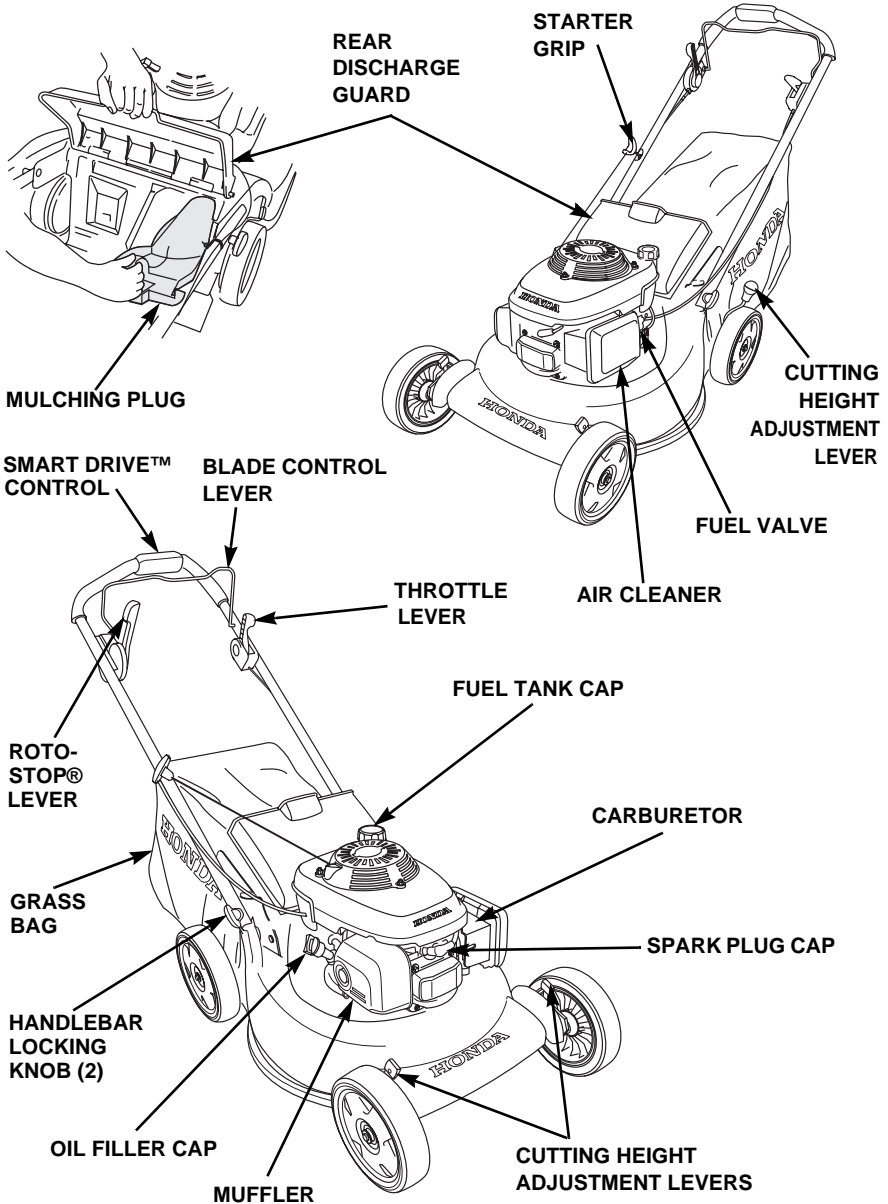

CONTROLS & FEATURES



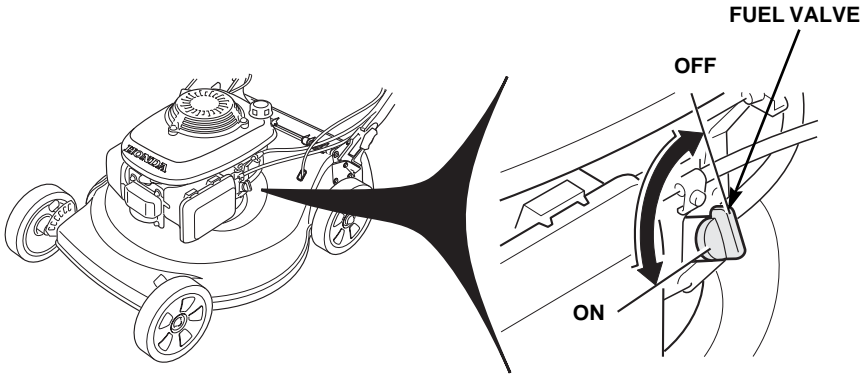

DESCRIPTION OF CONTROLS

Fuel Valve

The fuel valve controls fuel flow from the fuel tank to the carburetor. The fuel valve must be ON to start and operate the mower. The fuel valve should be kept OFF when the mower is not in use.



Throttle Lever

-  **CHOKE** For starting a cold engine.
-  **FAST** For restarting a warm engine and for mowing.
-  **SLOW** For idling the engine.
-  **STOP** For stopping the engine

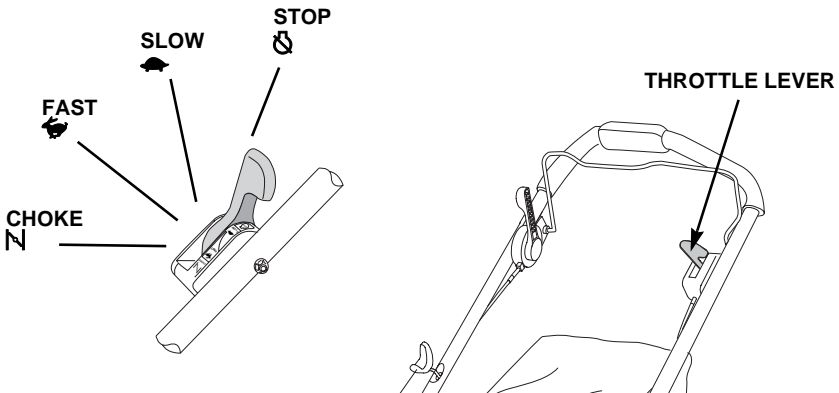

CONTROLS & FEATURES

Blade Control System

Blade rotation is controlled by the blade control lever and the Roto-Stop® lever.

Hold the blade control lever against the handlebar and push the Roto-Stop lever to engage the blade.

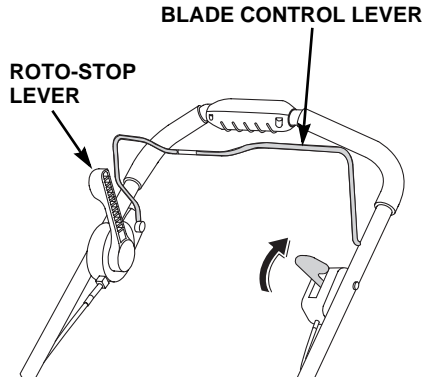

SMART DRIVE™ Control

The SMART DRIVE™ control engages and disengages the transmission that drives the rear wheels.

Ground speed is determined by the amount of pressure applied to the Smart Drive control.

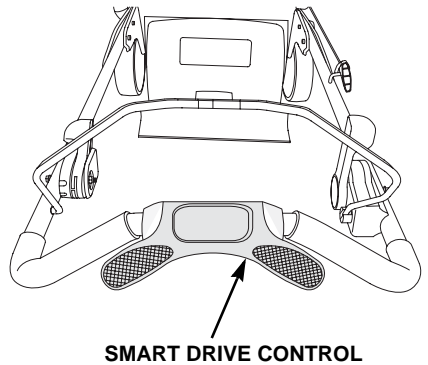

CONTROLS & FEATURES

Cutting Height Adjustment Levers

The mower deck height can be set to any of the seven approximate settings. Each wheel should be adjusted to the same position. To lower the deck, move the adjusters backward. To raise the deck, move the adjusters forward.

FRONT WHEELS:

Each front wheel has an independent adjustment lever.

**FRONT
ADJUSTMENT LEVER (2)**

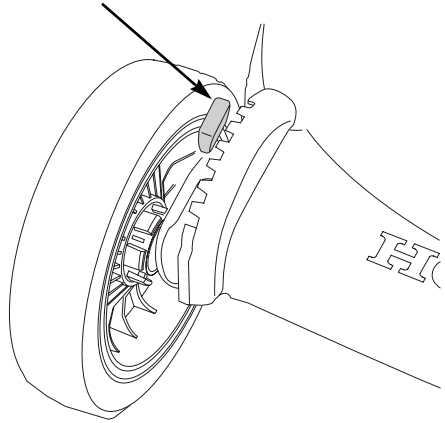

REAR WHEELS:

Both rear wheels are adjusted by a single adjustment lever located near the left rear wheel.

**REAR
ADJUSTMENT LEVER**

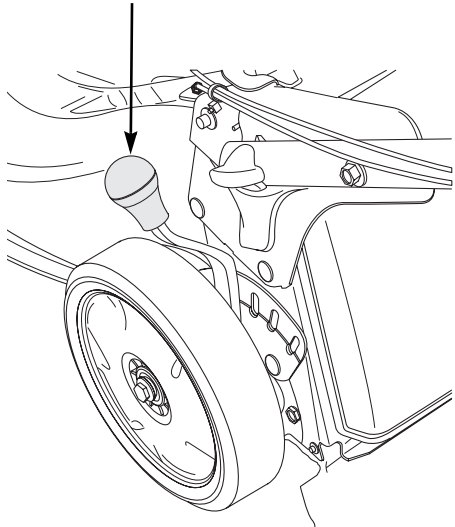

BEFORE OPERATION

ARE YOU READY TO GET STARTED?

Your safety is your responsibility. A little time spent in preparation will significantly reduce your risk of injury.

Knowledge

Read and understand this manual. Know what the controls do and how to operate them.

Familiarize yourself with the lawn mower and its operation before you begin using it. Know how to quickly shut off the lawn mower in case of an emergency.

IS YOUR LAWN MOWER READY TO GO?

For your safety, and to maximize the service life of your lawn mower, it is very important to take a few moments before you operate the lawn mower to check its condition. Be sure to take care of any problem you find, or have your servicing dealer correct it, before you operate the lawn mower.

WARNING

Improperly maintaining this lawn mower, or failing to correct a problem before operation, could cause a malfunction in which you could be seriously injured.

Always perform a pre-operation inspection before each operation, and correct any problem.

Before beginning your pre-operation checks, be sure the lawn mower is on a level surface.

BEFORE OPERATION

Check the General Condition of the Lawn Mower:

- Look around and underneath the lawn mower for signs of oil or gasoline leaks.
- Look for signs of damage.
- Check each control for proper operation.
- Check the blades for wear. Replace as necessary (page 25). Check that the blade bolts are tight (page 27).
- Check that all nuts, bolts, screws are tightened.

Check the Engine

- Check the air cleaner (page 31) and oil level (page 29).
- Check the fuel level (page 35). Starting with a full tank will help to eliminate or reduce operating interruptions for refueling.

CHECK YOUR WORK AREA

For your safety and the safety of others, always inspect the area before operating the lawn mower.

Objects

Anything which can be picked up by the blade and thrown is a potential hazard to you and others. Look for things like stones, sticks, nails, and wire, and remove them from the work area.

People and Pets

People and animals near the work area can move into your lawn mower's path or into a position where they could be struck by thrown objects. Clear the area of people, especially children and pets. Their safety is your responsibility.

Work Area

Check the condition of the grass. Adjust your lawn mower ground speed and mowing swath accordingly.

BEFORE OPERATION

GET THE LAWN MOWER READY

Mulching Plug

The mulching plug helps to curve the inside of the mower deck for more efficient mulching.

Install and remove the mulching plug by raising the rear discharge guard as shown. The mulching plug only fits one way. Remove the mulching plug when using a grass bag.

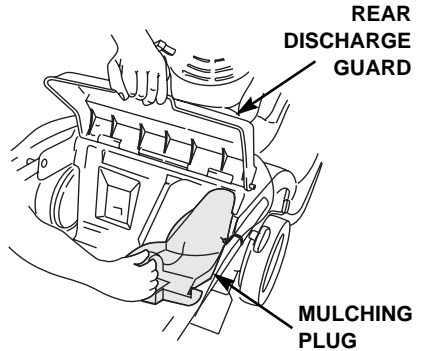

Cutting Height

Set all three adjustment levers to the same cutting height position. Each position changes the height approximately 1/2 inch (13 mm).

To adjust the cutting height, pull each adjustment lever toward the wheel, and move it into another notch.

If you are not sure what cutting height to select, start with a high setting and check the appearance of the lawn after mowing a small area. Readjust the cutting height if necessary.

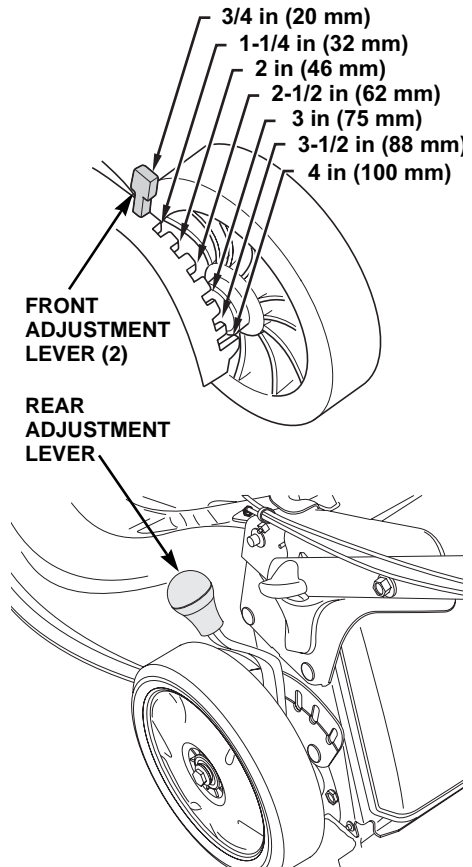

BEFORE OPERATION

Handlebar Height

The handlebar height can be adjusted to either one of the two height positions. See “Handlebar Setup” on page 44 for details.

Grass Bag

A lawn mower works like a vacuum cleaner; it blows air through the bag, which traps the grass clippings. Always empty the grass bag before it becomes filled to the limit of its capacity. Bagging performance will diminish after the bag becomes about 90% full. Also, the bag is easier to empty when not packed full.

Inspection

Inspect the grass bag before use. Check for holes, tears, and excessive wear. The grass bag does wear during normal use, and will eventually require replacement (page 28).

Installation

1. Raise the rear discharge guard and remove the mulching plug. Hook the grass bag frame onto the mower deck as shown.
2. Release the rear discharge guard to secure the grass bag in place.

Removal

1. Raise the rear discharge guard, grasp the grass bag handle, and remove the grass bag.
2. Release the rear discharge guard.
3. When the grass bag is clear of the rear discharge, you can lift the grass bag through the handlebars or remove it from the rear of the mower below the handlebar.

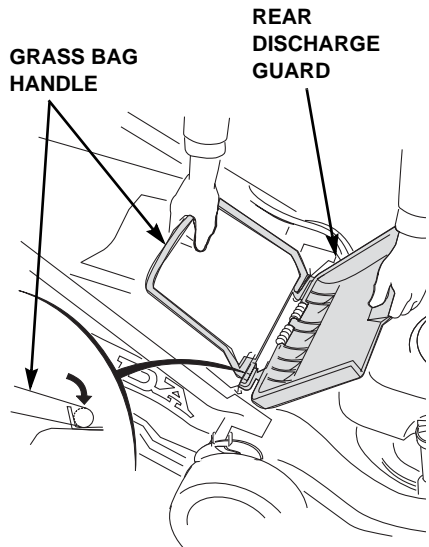

OPERATION

MOWING PRECAUTIONS

Before operating the mower for the first time, please review the *LAWN MOWER SAFETY* chapter beginning on page 4 and the *BEFORE OPERATION* chapter beginning on page 11.

Even if you have operated other mowers, take time to become familiar with how this mower works and practice in a safe area until you build up your skills.

For your safety, avoid starting or operating the engine in an enclosed area, such as a garage. Your mower's exhaust contains poisonous carbon monoxide gas which can collect rapidly in an enclosed area and cause illness or death.

STARTING THE ENGINE

Before starting the engine, the Smart Drive control must be released, preventing the mower from moving forward.

1. Turn the fuel valve to the ON position.

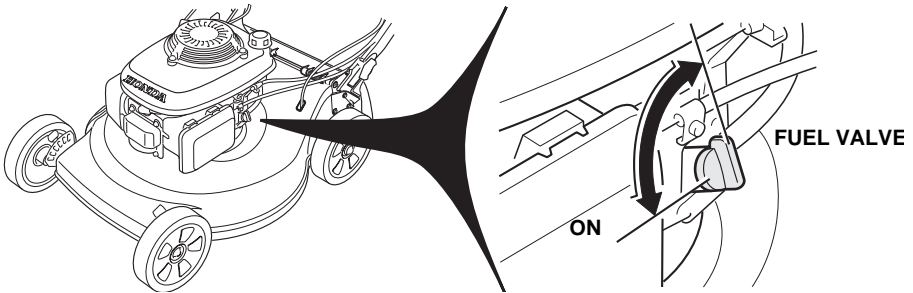

2. Move the throttle lever to **CHOKE** for a cold engine, or **FAST** for a warm engine.

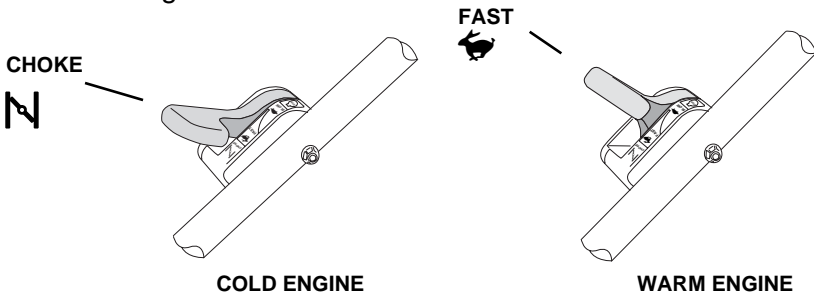

OPERATION

3. With the blade control lever released, pull the starter grip lightly until you feel resistance, then pull briskly. Return the starter grip gently.

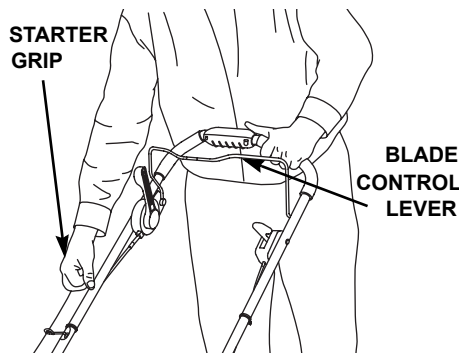

4. If the CHOKE position was used during starting, move the throttle lever away from the CHOKE position as soon as the engine warms up enough to run smoothly. Set the throttle lever at FAST to mow or at SLOW to idle.

OPERATING THE CONTROLS FOR MOWING

Throttle Lever

For best cut quality, always mow with the throttle lever in the FAST position. When the blades rotate at the preset fast speed, it creates a strong fan action that lifts and cuts grass more efficiently. Do not try to increase the preset engine speed as the blades could fracture and come apart.

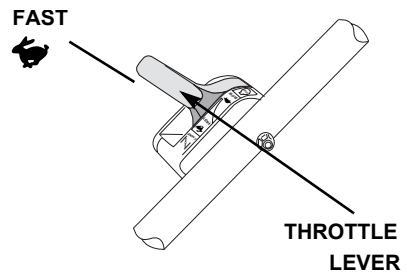

Blade Control System

Blade rotation is controlled by the blade control lever and the Roto-Stop lever.

1. Hold the blade control lever against the handlebar.
2. With the throttle lever in the FAST position, push the Roto-Stop lever forward until it reaches the end stop.

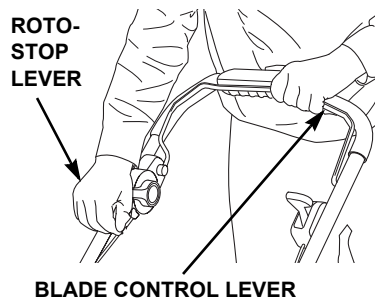

3. Release the Roto-Stop lever when the blades are engaged.
4. Continue to hold the blade control lever against the handlebar to maintain blade rotation.
5. Release the blade control lever to stop blade rotation. Always release the blade control lever before starting the engine to prevent the blades from turning.

Smart Drive Control

With the engine running and the blades rotating, slowly push the Smart Drive control to propel the mower forward.

Ground speed will increase as more pressure is applied to the Smart Drive control. Select a comfortable speed considering the mowing conditions.

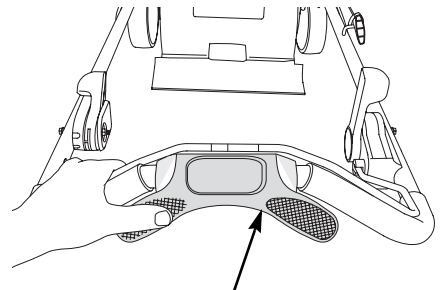

SMART DRIVE CONTROL

Release the Smart Drive control to disengage the rear wheels.

STOPPING THE ENGINE

1. Release the blade control lever to stop blade rotation.
2. Move the throttle lever to the STOP position to stop the engine.
3. When the mower is not in use, turn the fuel valve to OFF.

BLADE CONTROL LEVER

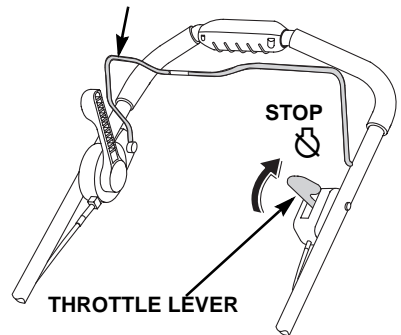

THROTTLE LEVER

SAFE MOWING PRACTICES

For your safety, keep all four wheels on the ground, and be careful to avoid losing your footing and control of the mower. Keep a firm grip on the handlebar and walk, never run, with the mower. Be very careful when mowing uneven or rough ground. If stuck, do not kick or push the mower with your foot. Use the handlebar only

OPERATION

WARNING

The blades are sharp and spin at high speed. A spinning blade can cut you severely and can amputate fingers and toes.

- Wear protective footwear
- Keep your hands and feet away from the mower deck while the engine is running.
- Stop the engine before performing any adjustment, inspection, or maintenance.

Slopes

Mow across slopes, not up and down. Avoid steep slopes (more than 20°), and be careful when changing direction. Mowing on a slope when the grass is damp or wet could cause you to slip, fall, and lose control of the mower.

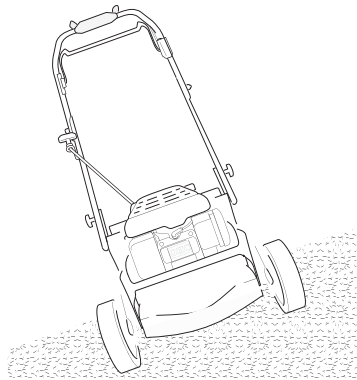

Obstacles

Use the side of the mower to cut close to obstacles, such as fences or walls. Release the Smart Drive control to disengage the drive when mowing around trees and other obstacles for better directional control. Be careful when mowing over obstacles embedded in the lawn, such as sprinkler heads, paving, edging, etc. Avoid anything sticking up above the surface of the lawn.

If the blade hits something, or if the mower starts to vibrate, stop the engine immediately, disconnect the spark plug cap, and check for damage (page 25). Striking objects may damage the blade, bend the crankshaft, and/or break the mower deck or other components. Vibration usually indicates serious trouble.

WARNING

A worn, cracked, or damaged blade can break, and pieces of the damaged blade can become dangerous projectiles.

Thrown objects can cause serious injury.

Inspect the blades regularly, and do not operate the mower with a worn or damaged blade.

The *Distributor's Limited Warranty* (page 57) does not cover parts damaged by accident or collision.

Gravel and Loose Objects

Gravel, loose stones, and landscaping material can be picked up by the mower and thrown many feet with enough force to cause serious personal injury and/or property damage. The best way to prevent potential injury from thrown objects is to release the blade control lever to stop the blade before reaching areas with gravel, loose stones, or landscaping material.

MOWING TIPS

When to Mow

Most grasses should be mowed when they have grown $\frac{1}{2}$ to 1 inch above their recommended height. More frequent mowing is required for mulching than for bagging. For best mulching results, you may need to mow the lawn twice a week during the growing season.



Cutting Height

Consult a local nursery or lawn and garden center for cutting height recommendations and advice about specific types of grasses and growing conditions in your area.



LONG ENOUGH

Most grass has stems and leaves. If you cut off the leaves, you'll scalp the lawn. Let the grass recover between mowings. Your mower will work better, and your lawn will look better.



TOO SHORT

OPERATION

If your grass gets too tall, cut it once at the highest cutting height setting, then mow again in 2 or 3 days. Don't take off more than one third of total grass height in any one mowing, or brown patches may develop. Cutting height adjustment is explained on page 10.

Cutting Width

For an even lawn finish, overlap each mowing swath by a few inches. If the grass is very tall or thick, use more overlap and a narrower mowing swath.

Blade Speed

The blades must spin very fast to cut properly. Always use the FAST throttle setting. If engine speed drops, it could mean the engine is being overloaded by the blades trying to cut too much grass. Mow a narrower swath, move the mower slower, install the discharge chute, or raise the cutting height.

Blade Sharpness

A sharp blade cuts cleanly. A dull blade tears the grass, leaving shredded ends that turn brown. When your blades don't cut cleanly anymore, have them sharpened or replaced.

Dry Grass

If the ground is too dry, mowing will stir up a lot of dust. Besides being unpleasant to work in, too much dust will clog the air filter. If dust is a problem, water your lawn the day before mowing. Mow when the grass is dry to your touch, but the soil is still moist.

Wet Grass

Wet grass is slippery and can make you lose your footing. Also, wet grass clippings will clog the mower deck and collect in clumps on the lawn. Always wait for wet grass to dry before mowing.

Fallen Leaves

When equipped with the grass bag, your mower can be used to pick up fallen leaves for disposal. If using the mower to bag large amounts of fallen leaves, and not for mowing, set the cutting height adjustment levers so the front of the mower deck is one or two settings higher than the rear.

If you want to mulch fallen leaves into your lawn, don't let the leaf cover get too deep before you begin. For best results, start mulching while grass still shows through the leaf cover. In places where fallen leaves completely cover the grass, remove the leaves by raking, or install a grass bag, so your mower can pick them up for disposal.

Clogged Mower Deck

Before clearing a clogged mower deck, stop the engine and turn the fuel valve to the OFF position. With the spark plug cap disconnected, tilt the mower so the air filter side is up.

Clear a clogged deck with a stick, not your hands.

Mowing Patterns

Your Honda mower will work most efficiently if you use the following mowing patterns as much as possible. Mower deck and equipment design, and the direction in which the blade rotates, cause these mowing patterns to give the best results.

Mulching

Use a counterclockwise mowing pattern. If the lawn has an irregular shape, or many obstacles, divide it into sections where you can use counterclockwise patterns.

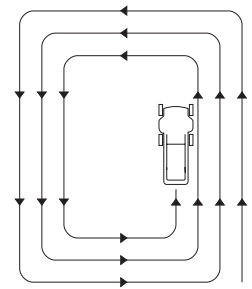

MULCHING PATTERN

Bagging

Use a clockwise mowing pattern. This will give the best bagging performance, leaving the least amount of clippings on the lawn.

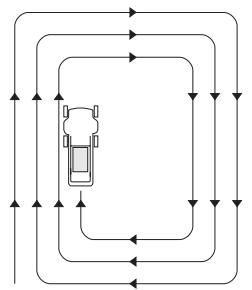

BAGGING PATTERN

SERVICING YOUR MOWER

THE IMPORTANCE OF PROPER MAINTENANCE

Proper maintenance is essential for safe, economical, and trouble-free operation. It will also help reduce air pollution.

WARNING

Improper maintenance, or failure to correct a problem before operation, can cause a malfunction in which you can be seriously hurt or killed.

Always follow the inspection and maintenance recommendations and schedules in this owner's manual.

To help you properly care for your mower, the following pages include a maintenance schedule, routine inspection procedures, and simple maintenance procedures using basic hand tools. Other service tasks that are more difficult, or require special tools, are best handled by professionals and are normally performed by a Honda technician or other qualified mechanic.

The maintenance schedule applies to normal operating conditions. If you operate your mower under severe conditions, such as sustained high-load or high-temperature operation, or use in unusually wet or dusty conditions, consult your servicing dealer for recommendations applicable to your individual needs and use.

Maintenance, replacement, or repair of the emission control devices and systems may be performed by any engine repair establishment or individual, using parts that are “certified” to EPA standards.

MAINTENANCE SAFETY

Some of the most important safety precautions follow. However, we cannot warn you of every conceivable hazard that can arise in performing maintenance. Only you can decide whether or not you should perform a given task.

WARNING

Failure to properly follow maintenance instructions and precautions can cause you to be seriously hurt or killed.

Always follow the procedures and precautions in the owner's manual.

Safety Precautions

- Make sure the engine is off before you begin any maintenance or repairs. This will eliminate several potential hazards:
 - **Carbon monoxide poisoning from engine exhaust.**
Be sure there is adequate ventilation whenever you operate the engine.
 - **Burns from hot parts.**
Let the engine and exhaust system cool before touching.
 - **Injury from moving parts.**
Do not run the engine unless instructed to do so.
- Read the instructions before you begin, and make sure you have the tools and skills required.
- To reduce the possibility of fire or explosion, be careful when working around gasoline. Use only a nonflammable solvent, not gasoline, to clean parts. Keep cigarettes, sparks, and flames away from all fuel-related parts.

Remember that an authorized Honda servicing dealer knows your mower best and is fully equipped to maintain and repair it.

To ensure the best quality and reliability, use only new, genuine Honda parts or their equivalents for repair and replacement.

SERVICING YOUR MOWER

MAINTENANCE SCHEDULE

ITEM	Perform at every indicated interval	REGULAR SERVICE PERIOD					See page	
		Before each use	After initial 20 hours	Every 50 hours	Every 100 hours	Every 150 hours		
Blades	Check condition	O					25	
	Check bolt torque	O					27	
Grass bag	Check	O					28	
Engine oil	Check	O					29	
	Change		O		O (1)		30	
Air cleaner	Check	O					31	
	Clean			O (1)				
	Replace					O (1)		
Spark plug	Check-Adjust				O		32	
	Replace					O		
Spark arrester (optional equipment)	Clean-Inspect				O		33	
Blade control cable	Adjust		O(2)		O(2)		–	
Smart Drive cable	Adjust		O		O		34	
Throttle cable	Adjust		O (2)		O (2)		–	
Valve clearance	Adjust					O (2)	–	
Pinion gears	Lubricate				O (2)		–	
Idle speed	Check-Adjust					O (2)	–	
Combustion chamber	Clean	After every 250 hours (2)						–
Fuel system	Clean tank/filter					O (2)	–	
	Check line	Every 2 years [replace every 4 years] (2)						–

(1) Service more frequently when used in dusty areas.

(2) These items should only be serviced by an authorized Honda servicing lawn mower dealer, unless you are mechanically proficient and have the proper tools. Refer to the Honda shop manual for service procedures.

Failure to follow this maintenance schedule could result in non-warrantable failures.

BLADES

1. Turn the fuel valve to the OFF position (page 8), and disconnect the spark plug cap from the spark plug (page 32).
2. Tilt the mower to the right, so the air filter side is up. This will help to prevent fuel leakage and hard starting.
3. Inspect the blades for wear and damage.

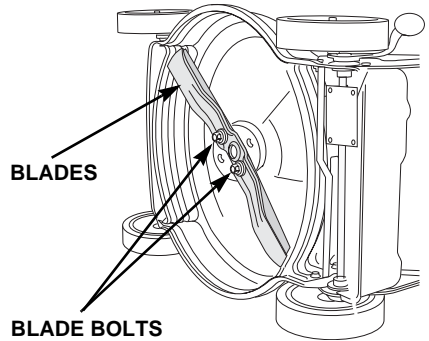

⚠ WARNING

A worn, cracked, or damaged blade can break, and pieces of the damaged blade can become dangerous projectiles.

Thrown objects can cause serious injury.

Inspect the blades regularly. Do not operate the mower with worn or damaged blades.

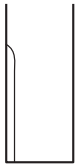

NORMAL



**EXCESSIVELY
WORN**



BENT



CRACKED

A dull blade can be sharpened, but a blade that is excessively worn, bent, cracked, or otherwise damaged must be replaced. A worn or damaged blade can break, causing blade pieces to be thrown from the mower.

When a blade needs sharpening or replacement, take the lawn mower to an authorized Honda servicing dealer. Or, if you have a torque wrench, you can remove and install the blades yourself (page 26).

Check that the blade bolts are tight (page 27).

SERVICING YOUR MOWER

Blade Removal and Installation

If you remove the blades for sharpening or replacement, use a torque wrench for installation. Wear heavy gloves to protect your hands.

BLADE SHARPENING: To avoid weakening the blades, or causing imbalance or poor cutting, the blades should be sharpened by trained staff at an authorized Honda servicing dealer.

BLADE REPLACEMENT: If replacing a blade, use a genuine Honda replacement blade or equivalent.

Blade Removal

1. Turn the fuel valve OFF. Disconnect the spark plug cap, then tilt the mower to the right side (air filter side up). This will help to prevent fuel leakage and hard starting due to carburetor flooding.
2. Remove the two blade bolts with a 14 mm wrench. Use a wooden block to prevent the blades from turning when removing the bolts. Remove the blades from the blade holder.

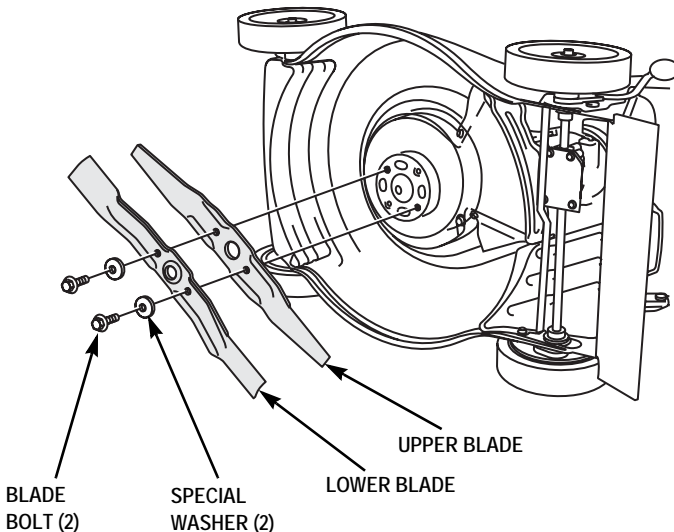

SERVICING YOUR MOWER

Blade Installation

1. Clean dirt and grass from around the blade mounting area.
2. Install the blades using the two blade bolts and special washers as shown (concave side of the special washers toward the blades).

The blade bolts and washers are specially designed for the mower. When replacing bolts and washers, use only genuine Honda replacement parts.

3. Tighten the blade bolts with a torque wrench. Use a wooden block to prevent the blades from turning when tightening the bolts.

Blade bolt torque: 36 ~ 43 ft-lb (49 ~ 59 N·m)

If you don't have a torque wrench, have an authorized Honda servicing dealer tighten the blade bolts before you use the mower. If the blade bolts are overtightened, they could break. If the blade bolts are not tightened enough, they could loosen or come out. In either case, it would be possible for the blades to fly off while you are operating the mower.

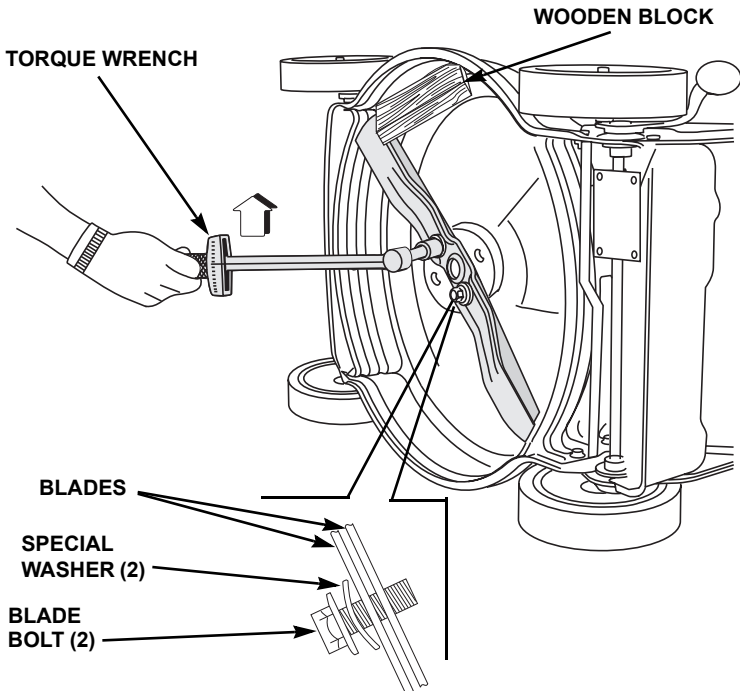

SERVICING YOUR MOWER

GRASS BAG CLEANING AND REPLACEMENT

Grass Bag Cleaning

Wash the bag with a garden hose, and allow it to dry completely before use; a wet bag will clog quickly.

Grass Bag Replacement

Carefully inspect the bag for wear, tears or holes. Replace a worn or damaged bag with a genuine Honda bag or its equivalent (page 56). Do not operate the lawn mower with a damaged grass bag.

Bag Removal

1. Unclip the plastic edges of the bag from the frame.
2. Remove the frame from the bag.

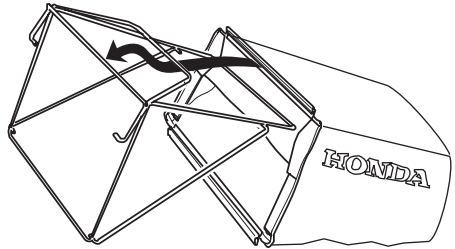

Bag Installation

1. Insert the frame into the new bag, as shown.
2. Clip the plastic edges of the bag onto the frame, as shown.

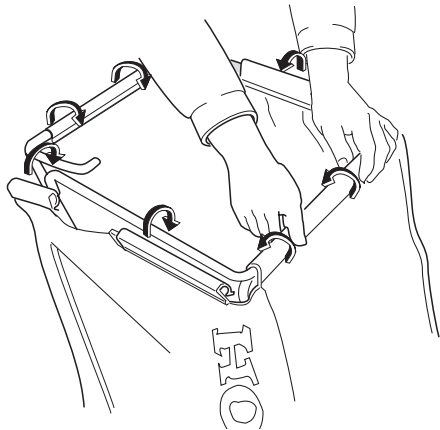

ENGINE MAINTENANCE

Engine Oil Level Check

1. Remove the dipstick and wipe it clean.
2. Insert and remove the dipstick **without screwing it into the filler neck**. Check the oil level shown on the dipstick.
3. If the oil level is low, add oil to bring the level between the upper and lower limit marks on the dipstick as shown. **Do not overfill**. If the engine is overfilled, the excess oil may transfer to the air cleaner housing and filter.

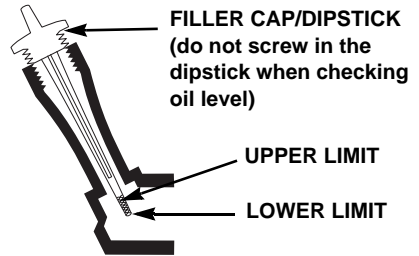
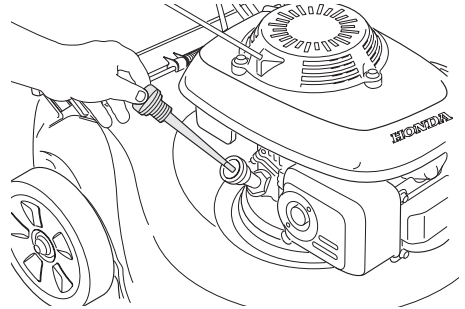

NOTICE

Running the engine with a low oil level can cause engine damage.

4. Screw in the filler cap/dipstick securely.

Engine Oil Recommendations

Oil is a major factor affecting performance and service life. Use 4-stroke automotive detergent oil.

SAE 10W-30 is recommended for general use. Other viscosities shown in the chart may be used when the average temperature in your area is within the recommended range.

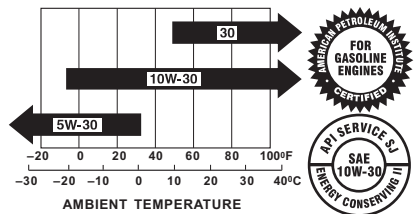

SERVICING YOUR MOWER

The SAE oil viscosity and service classification are in the API label on the oil container. Honda recommends that you use API SERVICE category SJ or later oil.

Engine Oil Change

Drain the used oil while the engine is warm. Warm oil drains quickly and completely.

1. Turn the fuel valve to the OFF position to reduce the possibility of fuel leakage (page 8).
2. Wipe the oil filler area clean, then remove the oil filler cap/dipstick.
3. Place a suitable container next to the mower to catch the used oil, then tilt the mower on its right side. The used oil will drain through the filler neck. Allow the oil to drain completely.

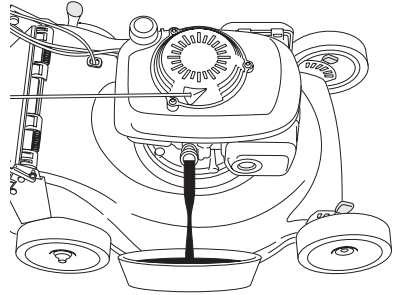

NOTICE

Improper disposal of engine oil can be harmful to the environment. If you change your own oil, please dispose of the used oil properly. Put it in a sealed container, and take it to a recycling center. Do not discard it in a trash bin or dump it on the ground.

4. Fill with the recommended oil. Do not overfill. Allow a couple of minutes for the oil to settle in the engine, then measure the oil level as shown on page 29.

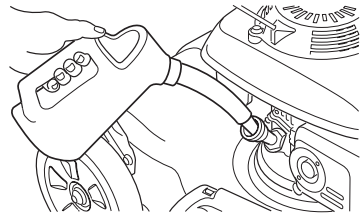

NOTICE

Using nondetergent oil can shorten the engine's service life, and using 2-stroke oil can damage the engine.

Air Cleaner Service

A dirty air filter restricts air flow to the carburetor, reducing engine performance. If you operate the mower in very dusty areas, clean the air filter more often than specified in the MAINTENANCE SCHEDULE (page 24).

NOTICE

Operating the engine without an air filter, or with a damaged filter, will allow dirt to enter the engine, causing rapid engine wear. This type of damage is not covered by the Distributor's Limited Warranty (page 57).

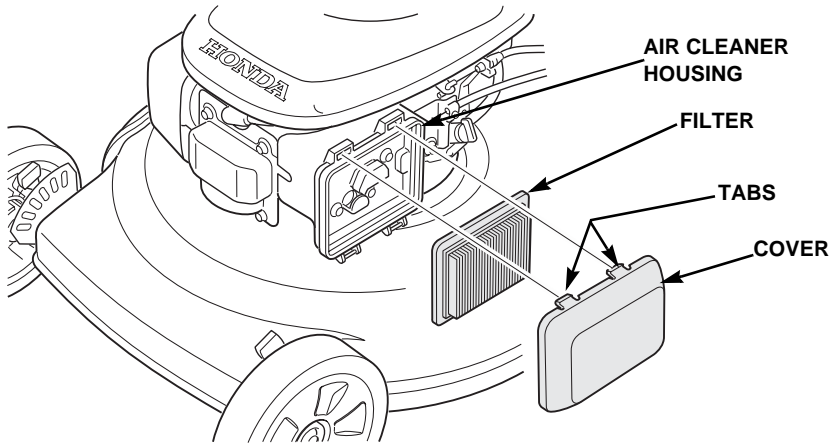

1. Press down on the cover tabs, then remove the cover.
2. Remove the filter and inspect it; if damaged, replace the filter.
3. Clean the filter by tapping the filter several times on a hard surface to remove dirt, or blowing compressed air [not exceeding 30 psi (207 kPa)] through the filter from the inside. Never try to brush off dirt; brushing will force dirt into the fibers.
4. Wipe dirt from the inside of the air cleaner housing and cover, using a moist rag. Be careful to prevent dirt from entering the air duct that leads to the carburetor.
5. Reinstall the filter and cover.

SERVICING YOUR MOWER

Spark Plug Service

Recommended spark plugs:

BPR6ES (NGK) or W20EPR-U (DENSO)

For good performance, the spark plug must be properly gapped and free of deposits.

NOTICE

An incorrect spark plug can cause engine damage

1. Disconnect the spark plug cap and remove dirt from the area.
2. Remove the spark plug with a spark plug wrench.
3. Inspect the plug; replace it if the electrodes are worn, or if the insulator is cracked or chipped
4. Set the gap to 0.028 ~ 0.031 in (0.7 ~ 0.8 mm).
5. Install the spark plug carefully, by hand, to avoid crossthreading.
6. After the plug seats, tighten it as follows to compress the washer:
Old plug: 1/8 to 1/4 turn
New plug: 1/2 turn

NOTICE

A loose spark plug can overheat and damage the engine. Overtightening the spark plug can damage the threads in the cylinder head.

7. Install the spark plug cap on the spark plug.

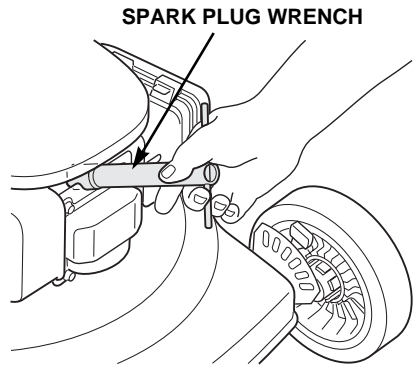
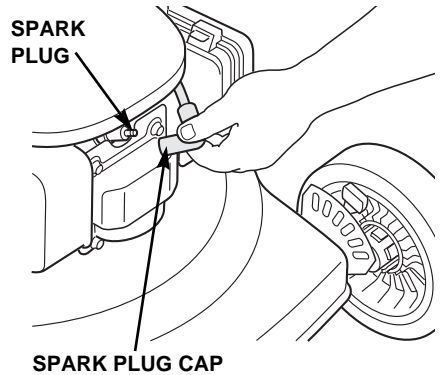

0.028 ~ 0.031 in
(0.7 ~ 0.8 mm)

SEALING
WASHER

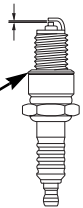

Spark Arrester Service (optional equipment)

Your lawn mower engine is not factory-equipped with a spark arrester. In some areas, it is illegal to operate an engine without a spark arrester. Check local laws and regulations. An optional USDA approved spark arrester is available from an authorized Honda servicing dealer. See page 56 for part numbers.

The spark arrester must be serviced every 100 hours to keep it functioning as designed.

1. Allow the engine to cool, then remove the bolts from the muffler shield. Remove the muffler shield.
2. Remove the two set screws and remove the spark arrester.
3. Check for carbon deposits on the spark arrester and the exhaust port. Use a brush to remove any carbon deposits from the screen. Replace the screen if it is torn or damaged.
4. Installation is the reverse of removal. Tighten all hardware securely.

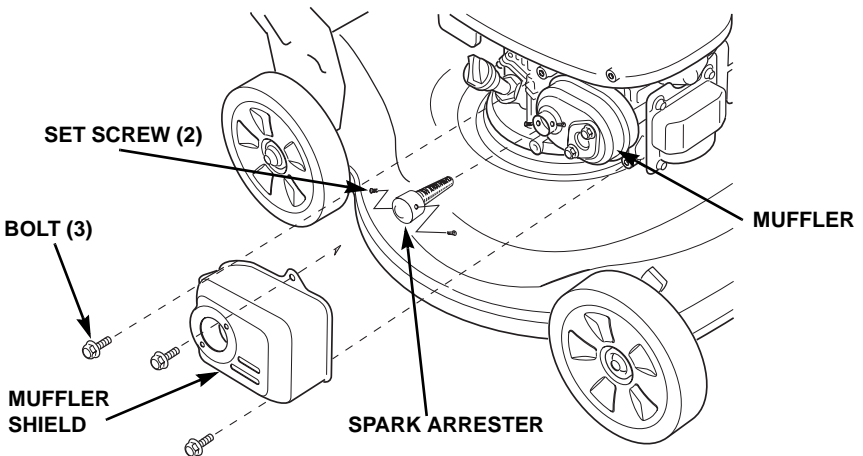

SERVICING YOUR MOWER

CONTROL CABLE ADJUSTMENTS

Smart Drive Cable Check

With the engine not running, apply finger pressure to the Smart Drive control until it stops.

Cable adjustment is correct if the Smart Drive control is aligned with the handlebar with finger pressure.

If the Smart Drive control is not properly aligned, adjust the cable as follows.

Smart Drive Cable Adjustment

If cable adjustment is required;

1. Loosen the jam nut from the adjuster.
2. Turn the adjuster in the loosen direction to move the Smart Drive control lever as shown.
3. Adjust the cable tension until the Smart Drive control lever aligns with the handlebar.
4. Tighten the jam nut to lock the adjuster in place.

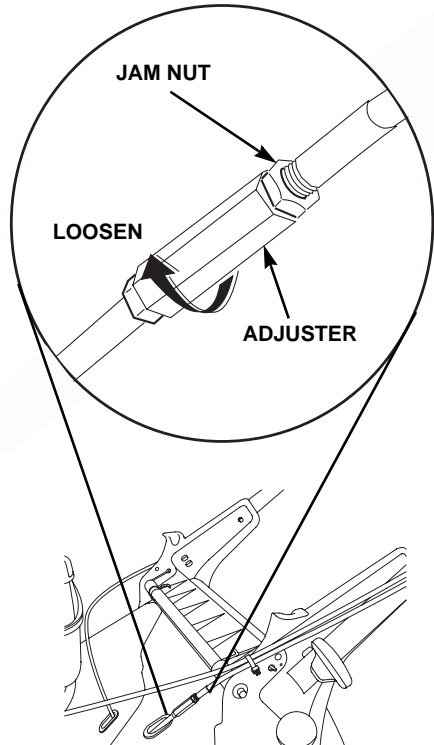
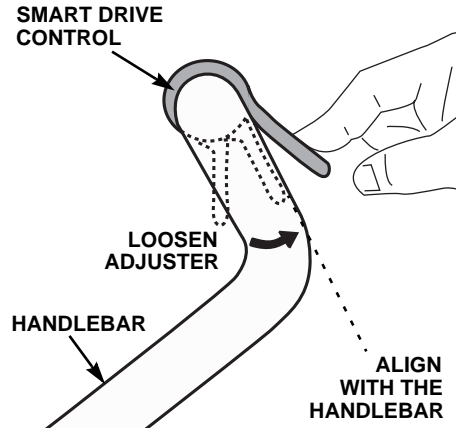

FUEL SYSTEM

Refueling

Fuel tank capacity: 0.29 US gal (1.1 ℓ)

If the fuel level is low, refuel in a well-ventilated area with the engine stopped. If the engine has been running, allow it to cool first.

To refuel, remove the fuel tank cap, and fill the tank with gasoline to the bottom of the filler neck. Refuel carefully to avoid spilling fuel. Do not overfill. There should be no fuel in the filler neck. After refueling, tighten the fuel tank cap securely.

WARNING

Gasoline is highly flammable and explosive. You can be burned or seriously injured when handling fuel.

- Stop the engine and keep heat, sparks, and flame away.
- Handle fuel only outdoors.
- Wipe up spills immediately.

Never refuel the engine inside a building where gasoline fumes may reach flames or sparks. Keep gasoline away from appliance pilot lights, barbecues, electric appliances, power tools, etc.

Spilled fuel is not only a fire hazard, it causes environmental damage. Wipe up spills immediately.

Move at least 10 feet (3 meters) away from the fueling source and site before starting the engine.

NOTICE

Fuel can damage paint and plastic. Be careful not to spill fuel when filling your fuel tank. Damage caused by spilled fuel is not covered by the Distributor's Limited Warranty (page 57).

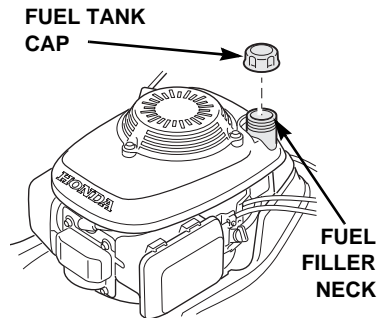

SERVICING YOUR MOWER

Fuel Recommendations

Use unleaded gasoline with a pump octane rating of 86 or higher.

These engines are certified to operate on unleaded gasoline. Unleaded gasoline produces fewer engine and spark plug deposits and extends exhaust system life.

Never use stale or contaminated gasoline or an oil/gasoline mixture. Avoid getting dirt or water in the fuel tank.

Occasionally you may hear light “spark knock” or “pinging” (metallic rapping noise) while operating under heavy loads. This is no cause for concern.

If spark knock or pinging occurs at a steady engine speed, under normal load, change brands of gasoline. If spark knock or pinging persists, see an authorized Honda servicing dealer.

NOTICE

Running the engine with persistent spark knock or pinging can cause engine damage.

This is considered misuse, and the *Distributor’s Limited Warranty* (page 57) does not cover parts damaged by misuse.

For oxygenated fuel information refer to page 49.

PREPARING FOR STORAGE

Proper storage preparation is essential for keeping your lawn mower trouble-free and looking good. The following steps will help to keep rust and corrosion from impairing your lawn mower's function and appearance, and will make the engine easier to start when you use the lawn mower again.

Cleaning

1. Wash the lawn mower, including the underside of the mower deck.

Engine

Wash the engine by hand, and be careful to prevent water from entering the air cleaner.

NOTICE

- *Using a garden hose or pressure washing equipment can force water into the air cleaner. Water in the air cleaner will soak the filter and can enter the carburetor or engine, causing damage.*
- *Water on a hot engine can cause damage. If the engine has been running, allow it to cool for at least half an hour before washing.*

Mower Deck

If using a garden hose or pressure washing equipment to clean the mower deck, be careful to avoid getting water into controls and cables, or anywhere near the engine air cleaner or muffler opening. Before washing the underside of the mower deck, be sure the fuel valve is in the OFF position. Disconnect the spark plug cap. Rest the mower on its right side, so the air filter side is up. This will help to prevent fuel leakage and hard starting due to carburetor flooding. Wear heavy gloves to protect your hands from the blade.

Grass Bag

Remove the grass bag from the mower and wash it with a garden hose or pressure washing equipment. Allow the bag to dry completely before storage.

2. After washing the lawn mower, wipe dry all accessible surfaces.
3. With the mower in an upright position, start the engine outdoors and let it run until it reaches normal operating temperature to evaporate any water remaining on the engine.
4. Stop the engine and allow it to cool.

STORAGE

5. After the lawn mower is clean and dry, touch up any damaged paint and coat other areas that may rust with a light film of oil. Lubricate the control cable cores with a silicone spray lubricant. (page 56)

Fuel

Gasoline will oxidize and deteriorate in storage. Old gasoline will cause hard starting, and it leaves gum deposits that clog the fuel system. If the gasoline in your mower deteriorates during storage, you may need to have the carburetor and other fuel system components, serviced or replaced.

The length of time that gasoline can be left in your fuel tank and carburetor without causing functional problems will vary with such factors as gasoline blend, your storage temperatures, and whether the fuel tank is partially or completely filled. The air in a partially filled fuel tank promotes fuel deterioration. Very warm storage temperatures accelerate fuel deterioration. Fuel deterioration problems may occur within a few months, or even less if the gasoline was not fresh when you filled the fuel tank.

The *Distributor's Limited Warranty* (page 57) does not cover fuel system damage or engine performance problems resulting from neglectful storage preparation.

You can extend fuel storage life by adding a fuel stabilizer that is formulated for that purpose, or you can avoid fuel deterioration problems by draining the fuel tank and carburetor.

Adding fuel stabilizer to extend fuel storage life

When adding a fuel stabilizer (page 56), fill the fuel tank with fresh gasoline. If only partially filled, air in the tank will promote fuel deterioration during storage. If you keep a container of gasoline for refueling, be sure that it contains only fresh gasoline.

1. Add fuel stabilizer following the manufacturer's instructions.
2. After adding a fuel stabilizer, run the engine outdoors for 10 minutes to be sure that treated gasoline has replaced the untreated gasoline in the carburetor.
3. Stop the engine, and turn the fuel valve to the OFF position. This turns off the fuel flow between the fuel tank and the carburetor.

Draining the Fuel Tank and Carburetor

1. Make sure the fuel valve is in the OFF position. Remove the carburetor drain bolt with a 10 mm wrench, and drain fuel from the carburetor bowl into an approved container.

⚠ WARNING

Gasoline is highly flammable and explosive. You can be burned or seriously injured when handling fuel.

- Stop the engine and keep heat, sparks, and flame away.
- Handle fuel only outdoors.
- Wipe up spills immediately.

2. Turn the fuel valve ON (page 8). This will allow fuel in the fuel tank to drain through the carburetor bowl.
3. After the fuel is completely drained, reinstall the drain bolt.

Engine Oil

Change the engine oil (page 30).

Engine Cylinder

1. Remove the spark plug (page 32).
2. Pour a tablespoon (5 ~ 10 cc) of clean engine oil into the cylinder.
3. Pull the starter rope several times to distribute the oil in the cylinder. Reinstall the spark plug.
4. Pull the starter rope slowly until resistance is felt, then return the starter grip gently. This closes the valves so moisture cannot enter.

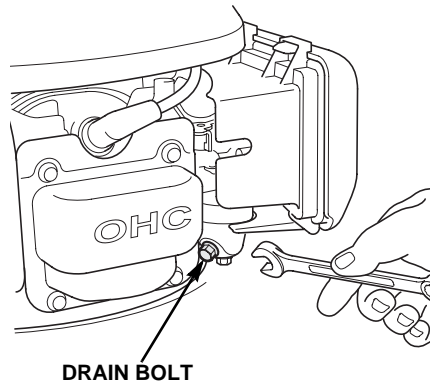

STORAGE

Handlebar Folding

Remove the grass bag (if installed). Twist the handlebar locking knobs 90 degrees to unlock the handle. Swing the handlebar down, being careful not to bend or pinch the cables.

HANDLEBAR
LOCKING KNOB (2)

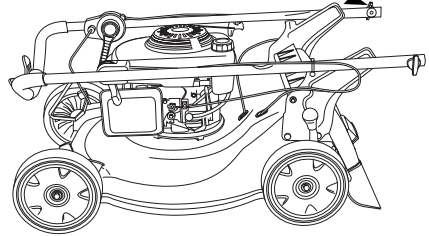

PLACING IN STORAGE

If your mower will be stored with gasoline in the fuel tank and carburetor, it is important to reduce the hazard of gasoline vapor ignition. Select a well-ventilated storage area away from any appliance that operates with a flame, such as a furnace, water heater, or clothes dryer. Also avoid any area with a spark-producing electric motor, or where power tools are operated.

If possible, avoid storage areas with high humidity, because that promotes rust and corrosion.

Unless all fuel has been drained from the fuel tank, turn the fuel valve to OFF to reduce the possibility of fuel leakage.

Place the mower with its wheels on a level surface. Tilting can cause fuel or oil leakage.

The handlebar can be folded for compact storage.

With the engine and exhaust system cool, cover the mower to keep out dust. A hot engine and exhaust system can ignite or melt some materials. Do not use sheet plastic as a dust cover. A nonporous cover will trap moisture around the mower, promoting rust and corrosion.

REMOVING FROM STORAGE

Check your mower as described in *BEFORE OPERATION* (page 11).

If the fuel was drained during storage preparation, fill the tank with fresh gasoline. If you keep a container of gasoline for refueling, be sure that it contains only fresh gasoline. Gasoline oxidizes and deteriorates over time, causing hard starting.

If the cylinder was coated with oil during storage preparation, the engine will smoke briefly at startup. This is normal.

TRANSPORTING

BEFORE LOADING

If the engine has been running, allow it to cool for at least 15 minutes before loading the mower on the transport vehicle. A hot engine and exhaust system can burn you and can ignite some materials.

1. Turn the fuel valve to the OFF position. This will prevent carburetor flooding and reduce the possibility of fuel leakage.

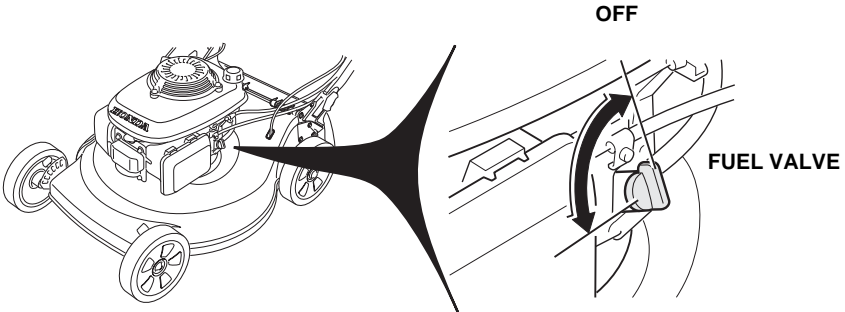

2. If equipped, remove the grass bag.

LOADING AND UNLOADING

If a suitable loading ramp is not available, two people should lift the mower on and off the transport vehicle while holding the mower level.

Position the mower so all four wheels are on the bed of the transport vehicle. Tie the mower down with rope or straps, and block the wheels. Keep the tie-down rope or straps away from the controls, adjustment levers, cables, and the carburetor.

The handlebar can be folded so the mower will take up less space (see page 40).

TAKING CARE OF UNEXPECTED PROBLEMS

ENGINE WILL NOT START

Possible Cause	Correction
Fuel valve is OFF	Turn the fuel valve ON (page 8)
Throttle lever is in the wrong position	Move the throttle lever to the CHOKE position, unless the engine is warm (page 15)
Out of fuel	Refuel (page 35)
Bad fuel; mower was stored without treating or draining gasoline, or refueled with bad gasoline	Drain the fuel tank and carburetor (page 39) Refuel with fresh gasoline (page 35)
Spark plug is faulty, fouled, or improperly gapped	Gap or replace the spark plug (page 32)
Spark plug is wet with fuel (flooded engine)	Dry and reinstall the spark plug. Start the engine with throttle lever in the FAST position.
Fuel filter is clogged, carburetor malfunction, ignition malfunction, valves stuck, etc.	Take the mower to an authorized Honda servicing dealer for repair

LOSS OF POWER

Possible Cause	Correction
Throttle is not set to FAST	Move the throttle to FAST (page 16)
Grass is too tall to cut	Raise the cutting height (page 10), cut a narrower swath (page 20), use a slower ground speed, or cut more frequently
Mower deck is clogged	Clean out the mower deck
Air filter is clogged	Clean or replace the air filter (page 31)
Bad fuel; mower stored without treating or draining gasoline, or refueled with bad gasoline	Drain the fuel tank and carburetor (page 39) Refuel with fresh gasoline (page 35)
Fuel filter is clogged, carburetor malfunction, ignition malfunction, valves stuck, etc.	Take the mower to an authorized Honda servicing dealer for repair

TAKING CARE OF UNEXPECTED PROBLEMS

VIBRATION PROBLEMS

Possible Cause	Correction
Grass and debris is lodged under the mower deck	Clean out the mower deck (page 21)
Blades are loose, bent, damaged, or unbalanced by improper sharpening	Tighten loose blades bolts. If the blades are found to be bent or damaged, take the lawn mower to an authorized Honda servicing dealer for inspection
Mechanical damage, such as a bent crankshaft	Take the mower to an authorized Honda servicing dealer for repair

MOWING AND BAGGING PROBLEMS

Possible Cause	Correction
Engine speed is too slow to cut well	Move the throttle lever to the FAST position (page 16)
Mower is moving too fast for lawn conditions	Turn the Smart Drive control to a slower position (page 17)
Adjustment levers are set at different positions	Set all levers at the same cutting height position (page 10)
Grass bag is overfilled or clogged	Empty the grass bag. Wash the grass bag if it is clogged with dirt (page 28)
Mower deck is clogged	Clear out the mower deck (page 21)
Blades are dull, worn, or damaged	Sharpen or replace the blades (page 26)

SET-UP

ASSEMBLY

Unpack the lawn mower and remove all the cardboard and paper from around the handlebar.

Handlebar Setup

1. Raise the handlebar into the mowing position with the handlebar adjust knobs in the unlock position.
2. Select the desired handlebar height by aligning the adjust knobs with the handlebar lower hole or the handlebar higher hole on the handle stay.
3. Turn the adjusting knobs 90 degrees into the lock position and the pins will spring into the holes and lock into position.

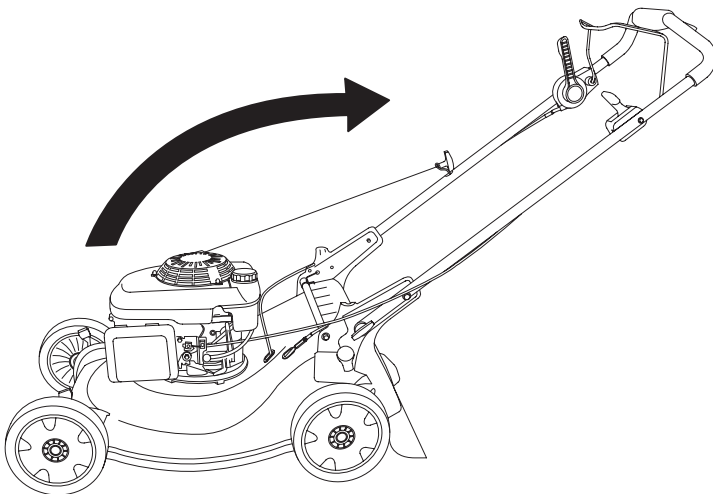
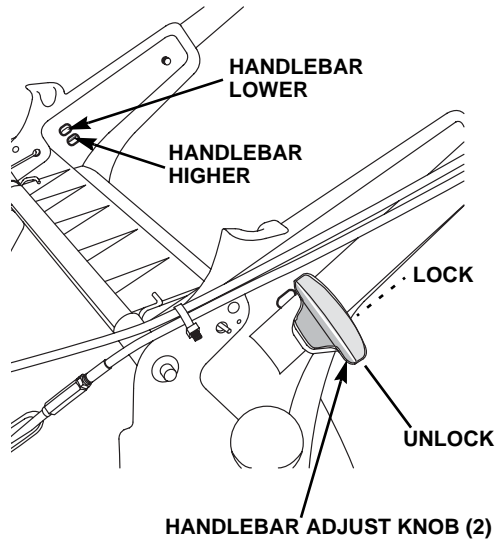

Grass Bag Assembly

Slide the grass bag frame into the grass bag and attach the clips as shown.

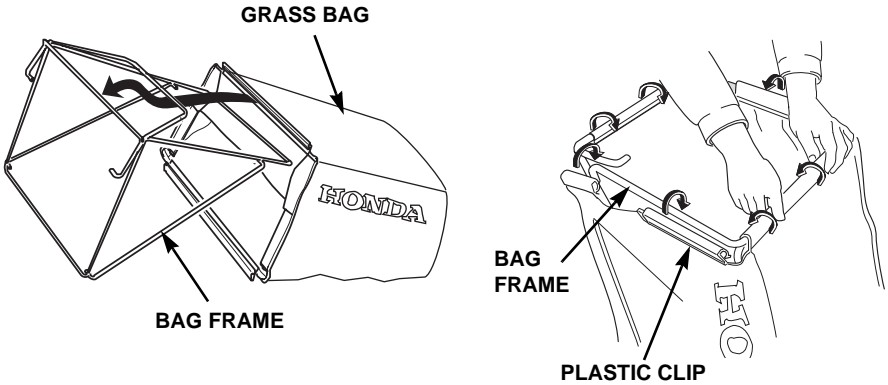

Lift the rear discharge guard, remove the mulching plug, then install the grass bag.

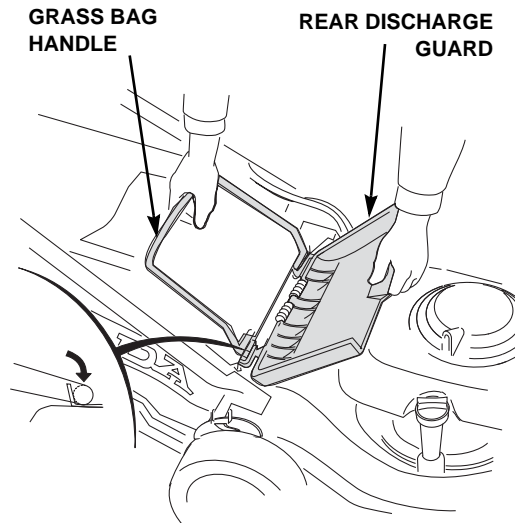

SET-UP

ENGINE OIL

The lawn mower is shipped **WITHOUT OIL** in the engine.

A bottle of oil is included in the box with your mower. Add the entire contents of the oil bottle into the oil filler opening. Check that the oil level is between the upper and lower limit marks on the dipstick as shown.

If the supplied oil is not used, add enough SAE 10W-30 API service category SJ or later oil. Add oil until the oil level is between the upper and lower limit marks.

Do not overfill engine oil. If the engine is overfilled, the excess oil may be transferred to the air cleaner housing and air filter.

For additional engine oil information, see page 29.

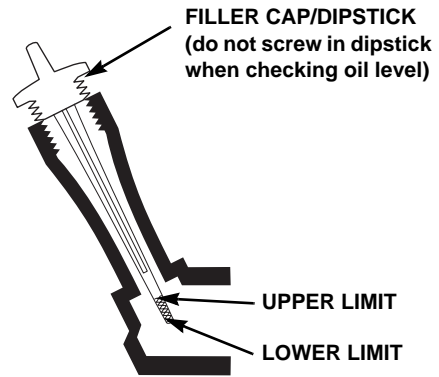
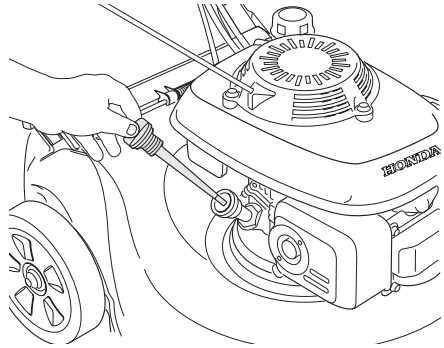

BEFORE OPERATION

Refer to page 35 for refueling instructions.

Before using the lawn mower, all mower operator's must read the following chapters and sections:

- **LAWN MOWER SAFETY** (page 4)
- **CONTROLS & FEATURES** (page 7)
- **BEFORE OPERATION** (page 11)
- **OPERATION** (page 15)
- **MAINTENANCE SCHEDULE** (page 24)

TECHNICAL & CONSUMER INFORMATION

TECHNICAL INFORMATION

Serial Number Locations

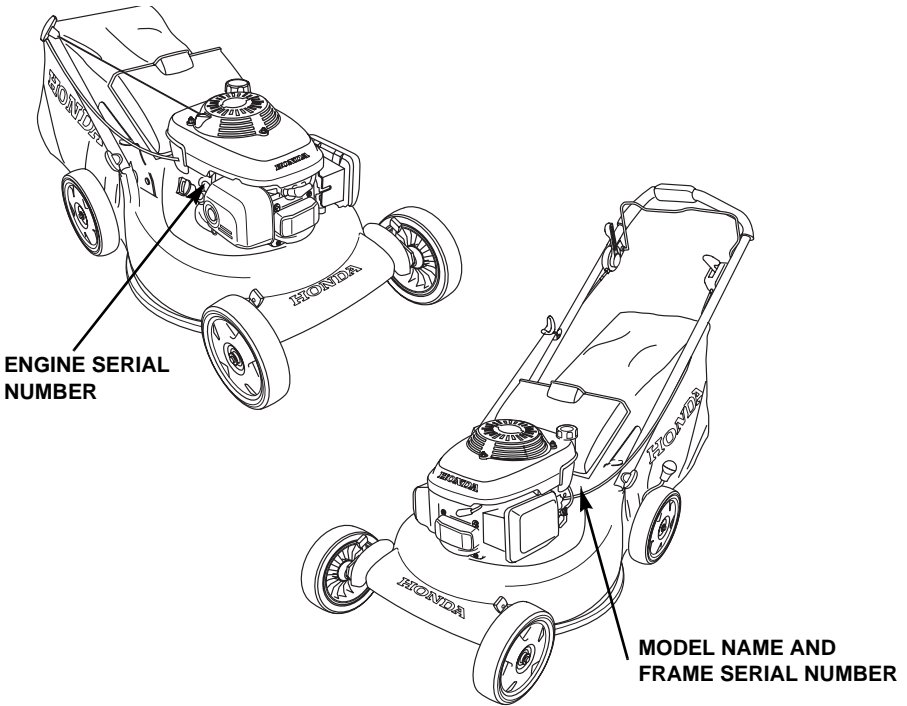

MEETS CPSC BLADE SAFETY REQUIREMENTS.

MODEL: HR_216__A AG
SERIAL NO: M__—_XXXXXX

AMERICAN HONDA MOTOR CO., INC.
ALPHARETTA, GA 30005-8847

There are two serial numbers, one for the mower frame and one for the engine. Record the frame and engine serial numbers in the space below. You will need these serial numbers when ordering parts and when making technical or warranty inquiries (page 62).

Engine serial number: _____

Frame serial number: _____

Date of purchase: _____

TECHNICAL AND CONSUMER INFORMATION

Carburetor Modification for High Altitude Operation

At high altitude, the standard carburetor air-fuel mixture will be too rich. Performance will decrease, and fuel consumption will increase. A very rich mixture will also foul the spark plug and cause hard starting. Operation at an altitude that differs from that at which this engine was certified, for extended periods of time, may increase emissions.

High altitude performance can be improved by specific modifications to the carburetor. If you always operate your mower at altitudes above 5,000 feet (1,500 meters), have your servicing dealer perform this carburetor modification. This engine, when operated at high altitude with the carburetor modifications for high altitude use, will meet each emission standard throughout its useful life.

Even with carburetor modification, engine horsepower will decrease about 3.5% for each 1,000-foot (300-meter) increase in altitude. The effect of altitude on horsepower will be greater than this if no carburetor modification is made.

NOTICE

When the carburetor has been modified for high altitude operation, the air-fuel mixture will be too lean for low altitude use. Operation at altitudes below 5,000 feet (1,500 meters) with a modified carburetor may cause the engine to overheat and result in serious engine damage. For use at low altitudes, have your servicing dealer return the carburetor to original factory specifications.

TECHNICAL AND CONSUMER INFORMATION

Oxygenated Fuels

Some conventional gasolines are being blended with alcohol or an ether compound. These gasolines are collectively referred to as oxygenated fuels. To meet clean air standards, some areas of the United States and Canada use oxygenated fuels to help reduce emissions.

If you use an oxygenated fuel, be sure it is unleaded and meets the minimum octane rating requirement.

Before using an oxygenated fuel, try to confirm the fuel's contents. Some states/provinces require this information to be posted on the pump.

The following are the EPA-approved percentages of oxygenates:

ETHANOL — (ethyl or grain alcohol) 10% by volume

You may use gasoline containing up to 10% ethanol by volume. Gasoline containing ethanol may be marketed under the name "Gasohol".

MTBE — (Methyl Tertiary Butyl Ether) 15% by volume

You may use gasoline containing up to 15% MTBE by volume.

METHANOL — (methyl or wood alcohol) 5% by volume

You may use gasoline containing up to 5% methanol by volume, as long as it also contains cosolvents and corrosion inhibitors to protect the fuel system.

Gasoline containing more than 5% methanol by volume may cause starting and/or performance problems. It may also damage metal, rubber, and plastic parts of your fuel system.

Fuel system damage or performance problems resulting from the use of an oxygenated fuel containing more than the percentages of oxygenates mentioned above are not covered under warranty.

TECHNICAL AND CONSUMER INFORMATION

EMISSION CONTROL SYSTEM

Source of Emissions

The combustion process produces carbon monoxide, oxides of nitrogen, and hydrocarbons. Control of hydrocarbons and oxides of nitrogen is very important because, under certain conditions, they react to form photochemical smog when subjected to sunlight. Carbon monoxide does not react in the same way, but it is toxic.

Honda uses lean carburetor settings and other systems to reduce the emissions of carbon monoxide, oxides of nitrogen, and hydrocarbons.

The U.S., California Clean Air Act and Environment Canada

EPA, California and Canadian regulations require all manufacturers to furnish written instruction describing the operation and maintenance of emission control systems.

The following instructions and procedures must be followed in order to keep the Honda engine emissions within the emission standards.

Tampering and Altering

Tampering with or altering the emission control system may increase emissions beyond the legal limit. Some acts that constitute tampering are:

- Removal or alteration of any part of intake, fuel, or exhaust system.
- Altering or defeating the speed-adjusting mechanism to cause the engine to operate outside its design parameters.

Problems That May Affect Emissions

If you are aware of any of the following symptoms, have your engine inspected and repaired by your authorized Honda servicing dealer.

- Hard starting or stalling after starting
- Rough idle
- Misfiring or backfiring under load
- Afterburning (backfiring)
- Black exhaust smoke or high fuel consumption

Replacement Parts

The emission control systems on your new Honda engine were designed, built, and certified to conform with EPA, California and Canadian emission regulations. We recommend the use of genuine Honda parts whenever you have maintenance done. These original-design replacement parts are manufactured to the same standards as the original parts, so you can be confident of their performance. The use of replacement parts that are not of the original design and quality may impair the effectiveness of your emission control system.

A manufacturer of an aftermarket part assumes the responsibility the part will not adversely affect emission performance. The manufacturer or rebuilder of the part must certify that use of the part will not result in a failure of the engine to comply with emission regulations.

Maintenance

Follow the *MAINTENANCE SCHEDULE* on page 24. Remember that this schedule is based on the assumption that your mower will be used for its designed purpose. Sustained high-load or high-temperature operation, or use in unusually wet or dusty conditions, will require more frequent service.

TECHNICAL AND CONSUMER INFORMATION

Air Index

An Air Index Information hang tag/label is applied to engines certified to an emission durability time period in accordance with the requirements of the California Air Resources Board.

There is a bar graph on the hang tag that is intended to provide you, our customer, the ability to compare the emissions performance of available engines. The lower the Air Index, the less pollution.

The durability description is intended to provide you with information relating the engine's emission durability period. The descriptive term indicates the useful life period for the engine's emission control system. See your *Emission Control System Warranty* (page 59) for additional information.

Descriptive Term	Applicable to Emissions Durability Period
Moderate	50 hours (0–65 cc) 125 hours (greater than 65 cc)
Intermediate	125 hours (0–65 cc) 250 hours (greater than 65 cc)
Extended	300 hours (0–65 cc) 500 hours (greater than 65 cc)

The Air Index Information hang tag/label must remain on the mower until it is sold. Remove the hang tag before operating the mower.

TECHNICAL AND CONSUMER INFORMATION

SPECIFICATIONS

Frame

Model	HRR216
Type	VXA
Length	63 in (1600 mm)
Width	23.0 in (582 mm)
Overall height	40.4 in (1027 mm)
Dry weight	94.1 lb (42.7 kg)
Cutting width	21.0 in (530 mm)
Cutting height (7 adjustable positions)	3/4 ~ 4 in (20 ~ 100 mm)
Wheel base	24.8 in (630 mm)
Fuel tank capacity	0.29 US gal (1.1ℓ)
Engine oil capacity	0.58 US qt (0.55ℓ)

Engine

Model	GCV160
Engine type	4-stroke, overhead-cam, single-cylinder, air-cooled
Displacement	9.8 cu in (160 cc)
Bore and stroke	2.52 x 1.97 in (64 x 50 mm)
Compression ratio	8.5:1
Ignition system	Transistorized magneto
* Maximum horsepower	5.5 bhp (4.1 kW) @ 3,600 rpm
Maximum torque	8.4 ft-lb (11 N•m) @ 2,500 rpm

* Horsepower rating (shown as maximum power output at 3,600 rpm) is in accordance with SAE J1995. Actual engine power will be lower. Engine power depends on accessories, operating speeds, operating conditions, and other variables.

Transmission

Type	Variable speed Thumb or hand operation (twist grip)
Ground speed	0 ~ 3.8 mph (0 ~ 6.1 km/h)

TECHNICAL AND CONSUMER INFORMATION

Maintenance

Fuel	Unleaded gasoline with a pump octane rating of 86 or higher	page 36
Engine oil	SAE 10W-30	page 29
Transmission lubricant	SAE 10W-30	Shop manual
Spark plug type	Regular: NGK - BP6ES DENSO - W20EP-U Resistor: NGK - BPR6ES DENSO - W20EPR-U	page 32
Maximum governed speed	2,950 ~ 3,100 rpm	Shop manual
Throttle cable	Adjust for proper choke operation and maximum governed speed.	Shop manual
Smart Drive cable	Adjust for proper control alignment	page 34
Blade bolt torque	36 ~ 43 ft-lb (49 ~ 59 N•m)	page 27

Tuneup

Spark plug gap	0.028 ~ 0.031 in (0.7 ~ 0.8 mm)	page 32
Idle speed	1,700 ± 150 rpm	Shop manual
Valve clearance (cold)	Intake: 0.15 ± 0.04 mm Exhaust: 0.20 ± 0.04 mm	Shop manual
Other specifications	No other adjustments needed.	

TECHNICAL AND CONSUMER INFORMATION

CONSUMER INFORMATION

Dealer Locator Information

To find an Authorized Honda Servicing Dealer anywhere in the United States:

Call (800) 426-7701

or visit our website:

www.hondapowerequipment.com/dealer

Customer Service

See page 62.

Honda Publications

These publications will give you additional information for maintaining and repairing your lawn mower.

Shop Manual

This manual covers complete maintenance and overhaul procedures. It is intended to be used by a skilled technician. Available through your Honda dealer or through Helm Inc. at 1 888-292-5395 or visit www.Hondapowerequipment.com > product manuals.

Parts Catalog

This manual provides complete, illustrated parts lists, and is available through your Honda dealer.

TECHNICAL AND CONSUMER INFORMATION

Replacement Parts, Optional Equipment, and Service Items

Contact an authorized Honda servicing dealer to purchase any of these (or other) accessories or genuine replacement parts. Be sure to have the lawn mower frame and engine serial numbers when you contact your dealer (page 47).

Replacement Parts

Item	Part Number	Notes
Grass bag	81320-VL0A-B000	Fabric bag only, no frame
Upper mulching blade	72531-VE2-0201	Always use an upper and lower blade.
Lower mulching high-lift blade	72511-VE1-0200	
Spark plug	98079-56846	NGK: BPR6ES
Air filter	17211-ZL8-023	

Optional Equipment

Item	Part Number	Notes
Spark arrester kit	06180-Z0J-000	
Spark arrester parts	18350-ZL8-000	Arrester and deflector
	18356-ZL8-000	ID plate
	90055-ZE1-000	Screw
Side discharge chute kit	06814-VG4-010	
Fast funnel	08C25-FST-000	Disposable and spill-free
ECO gas can	06176-0020	2 gallon spill-control type (CARB)

Service Items

Item	Part Number	Notes
SAE 10W-30 engine oil	08207-10W30	Genuine Honda recommended oil
Silicone spray	08209-0001	Lubricates control cable cores
Fuel stabilizer	08732-0001	For long term storage

TECHNICAL AND CONSUMER INFORMATION

Distributor's Limited Warranty

PRODUCTS COVERED BY THIS WARRANTY	LENGTH OF WARRANTY (from date of original retail purchase)	
	Noncommercial/Nonrental	Commercial/Rental
HRR Lawn Mowers	24 months	3 months

To Qualify for this Warranty:

The product must be purchased in the United States, Puerto Rico, or the U.S. Virgin Islands from American Honda or a dealer authorized by American Honda to sell those products. This warranty applies to the first retail purchaser and each subsequent owner during the applicable warranty time period.

What American Honda will Repair or Replace Under Warranty:

American Honda will repair or replace, at its option, any part that is proven to be defective in material or workmanship under normal use during the applicable warranty time period. Warranty repairs and replacements will be made without charge for parts or labor. Anything replaced under warranty becomes the property of American Honda Motor Company, Inc. All parts replaced under warranty will be considered as part of the original product and any warranty on those parts will expire coincident with the original product warranty.

To Obtain Warranty Service:

You must take the Honda lawn mower and proof of original retail purchase date, at your expense, to any Honda Power Equipment dealer in the United States, Puerto Rico, or the U.S. Virgin Islands who is authorized to service that product, during the dealer's normal business hours. If you are unable to obtain warranty service, or are dissatisfied with the warranty service you receive, take the following steps: First, contact the owner of the dealership involved; normally this should resolve the problem. However, if you should require further assistance, write or call the Power Equipment Customer Relations Department of American Honda Motor Co., Inc. Refer to page 62 for contact information.

Exclusions:

This warranty does not extend to parts affected or damaged by accident and/or collision, normal wear, fuel contamination or deterioration, use in an application for which the product was not designed, or any other misuse, neglect, incorporation or use of unsuitable attachments or parts, unauthorized alteration, or any causes other than defects in material or workmanship of the product.

Mower blades and mower deck housings are specifically not warranted against impact damage, including but not limited to, abrasive damage.

Disclaimer of Consequential Damage and Limitation of Implied Warranties: American Honda disclaims any responsibility for loss of time or use of the product, transportation, commercial loss, or any other incidental or consequential damage. Any implied warranties are limited to the duration of this written limited warranty. Some states do not allow limitations on how long an implied warranty lasts and/or do not allow the exclusion or limitation of incidental or consequential damages, so the above exclusions and limitations may not apply to you.

This warranty gives you specific legal rights, and you may also have other rights which vary from state to state.

TECHNICAL AND CONSUMER INFORMATION

Accessories, Replacement Parts, and Apparel Warranty

This warranty is limited to Honda Power Equipment parts, accessories and apparel when distributed by American Honda Motor Co., Inc., 4900 Marconi Drive, Alpharetta, Georgia 30005-8847

PRODUCTS COVERED BY THIS WARRANTY	LENGTH OF WARRANTY (from date of original retail purchase)	
	Noncommercial/Nonrental	Commercial/Rental
Accessories	12 months	3 months
Replacement Parts	6 months	3 months
Apparel	6 months	3 months

To Qualify for this Warranty:

1. The accessories, replacement parts, or apparel must be purchased from American Honda, or a dealer, distributor or distributor's dealer authorized by American Honda to sell those products in the United States, Puerto Rico, and the U.S. Virgin Islands.
2. You must be the first retail purchaser. This warranty is not transferable to subsequent owners.

What American Honda will Repair or Replace Under Warranty:

American Honda will repair or replace, at its option, any power equipment accessories, replacement parts, or apparel that are proven to be defective in material or workmanship under normal use during the applicable warranty time period. Anything replaced under warranty becomes the property of American Honda Motor Company, Inc. All parts replaced under warranty will be considered as part of the original product and any warranty on those parts will expire coincident with the original product warranty.

Accessories and replacement parts, installed by a dealer who is authorized by American Honda to sell them, will be repaired or replaced under warranty without charge for parts or labor. If installed by anyone else, accessories and replacement parts will be repaired or replaced under warranty without charge for parts, but any labor charges will be the responsibility of the purchaser. Apparel will be repaired or replaced under warranty without any charge.

To Obtain Warranty Service:

You must take the Honda Power Equipment accessory, replacement part, apparel or the power equipment on which the accessory or replacement part is installed, and proof of purchase, at your expense, to any Honda Power Equipment dealer in the United States, Puerto Rico, or the U.S. Virgin Islands who is authorized to service that product, during the dealer's normal business hours. If you are unable to obtain warranty service, or are dissatisfied with the warranty service you receive, take the following steps: First, contact the owner of the dealership involved; normally this will resolve the problem. However, if you should require further assistance, write or call the Power Equipment Customer Relations Department of American Honda Motor Co., Inc. Refer to page 62 for contact information.

Exclusions:

This warranty does not extend to accessories, parts, or apparel affected or damaged by accident and/or collision, normal wear, use in an application for which the product was not designed, or any other misuse, neglect, incorporation or use of unsuitable attachments or parts, unauthorized alteration, improper installation, or any causes other than defects in material or workmanship of the product.

Mower blades and mower deck housings are specifically not warranted against impact damage, including but not limited to, abrasive damage.

Disclaimer of Consequential Damage and Limitation of Implied Warranties:

American Honda disclaims any responsibility for loss of time or use of the product, or the power equipment on which the product is installed, transportation, commercial loss, or any other incidental or consequential damage. Any implied warranties are limited to the duration of this written warranty. Some states do not allow limitations on how long an implied warranty lasts and/or do not allow the exclusion or limitation of incidental or consequential damages, so the above exclusions and limitations may not apply to you. This warranty gives you specific legal rights, and you may also have other rights which vary from state to state.

TECHNICAL AND CONSUMER INFORMATION

Emission Control System Warranty

Your new Honda Power Equipment engine complies with the U.S. EPA, Environment Canada and State of California emission regulations. American Honda Motor Co., Inc. provides the emission warranty coverage for engines in the United States, and its territories. Honda Canada Inc. provides the emission warranty for engines in the 13 provinces and territories of Canada. In the remainder of this Emission Control System Warranty, American Honda Motor Company Inc. and Honda Canada Inc. will be referred to as Honda.

Your Warranty Rights And Obligations:

California

The California Air Resources Board and Honda are pleased to explain the emission control system warranty on your Honda Power Equipment engine. In California, new utility and lawn and garden equipment engines must be designed, built and equipped to meet the State's stringent anti-smog standards.

Other States, U.S. territories and Canada

In other areas of the United States and in Canada, your engine must be designed, built, and equipped to meet the U.S. EPA and Environment Canada emission standards for spark-ignited engines at or below 19 kilowatts.

All of the United States and Canada

Honda must warrant the emission control system on your power equipment engine for the period of time listed below provided there has been no abuse, neglect or improper maintenance of your power equipment engine. Where a warrantable condition exists, Honda will repair your power equipment engine at no cost to you including diagnosis, parts and labor.

Your emission control system may include such parts as the carburetor or fuel injection system, the ignition system, and catalytic converter. Also included may be hoses, connectors and other emission-related assemblies.

Manufacturer's Warranty Coverage:

The 1995 and later power equipment engines are warranted for two years. If any emission-related part on your engine is defective, the part will be repaired or replaced by Honda.

Owner's Warranty Responsibility:

As the power equipment engine owner, you are responsible for the performance of the required maintenance listed in your owner's manual. Honda recommends that you retain all receipts covering maintenance on your power equipment engine, but Honda cannot deny warranty coverage solely for the lack of receipts or for your failure to ensure the performance of all scheduled maintenance.

As the power equipment engine owner, you should however be aware that Honda may deny you warranty coverage if your power equipment engine or a part has failed due to abuse, neglect, improper maintenance, or unapproved modifications.

You are responsible for presenting your power equipment engine to a Honda Power Equipment dealer as soon as a problem exists. The warranty repairs should be completed in a reasonable amount of time, not to exceed 30 days.

If you have any questions regarding your warranty rights and responsibilities, you should write or call the Honda office in your region.

American Honda Motor Co., Inc.
Power Equipment Customer Relations
4900 Marconi Drive
Alpharetta, Georgia 30005-8847
Telephone: (770) 497-6400

or

Honda Canada Inc.
Power Equipment Customer Relations
715 Milner Avenue
Toronto, ON M1B 2K8
Telephone: (888) 946-6329

TECHNICAL AND CONSUMER INFORMATION

Warranty Coverage:

Honda power equipment engines manufactured after January 1, 1995 and sold in the State of California, and U.S. EPA certified engines manufactured on or after September 1, 1996 and sold in all of the United States, and Canadian certified engines manufactured on or after January 1, 2005 are covered by this warranty for a period of two years from the date of delivery to the original retail purchaser. This warranty is transferable to each subsequent purchaser for the duration of the warranty period.

Warranty repairs will be made without charge for diagnosis, parts or labor. All defective parts replaced under this warranty become the property of Honda. Warranted parts are listed under *Emission Control System Warranty Parts* on page 61. Normal maintenance items, such as spark plugs and filters, that are on the warranted parts list are warranted up to their required replacement interval only.

Honda is also liable for damages to other engine components caused by a failure of any warranted part during the warranty period.

Only Honda approved replacement parts may be used in the performance of any warranty repairs and must be provided without charge to the owner. The use of replacement parts not equivalent to the original parts may impair the effectiveness of your engine emission control system. If such a replacement part is used in the repair or maintenance of your engine, and an authorized Honda dealer determines it is defective or causes a failure of a warranted part, your claim for repair of your engine may be denied. If the part in question is not related to the reason your engine requires repair, your claim will not be denied.

To Obtain Warranty Service:

You must take your Honda Power Equipment engine or the product on which it is installed, along with your warranty registration card or other proof of original purchase date, at your expense, to any Honda Power Equipment dealer who is authorized by Honda to sell and service that Honda product during his normal business hours. Claims for repair or adjustment found to be caused solely by defects in material or workmanship will not be denied because the engine was not properly maintained and used.

If you are unable to obtain warranty service, or are dissatisfied with the warranty service you received, contact the owner of the dealership involved. Normally this should resolve your problem. However, if you require further assistance, write or call the Power Equipment Customer Relations Department of American Honda Motor Co., Inc. Refer to page 62 for contact information.

TECHNICAL AND CONSUMER INFORMATION

Exclusions:

Failures other than those resulting from defects in material or workmanship are not covered by this warranty. This warranty does not extend to emission control systems or parts which are affected or damaged by owner abuse, neglect, improper maintenance, misuse, misfueling, improper storage, accident and/or collision, the incorporation of, or any use of, any add-on or modified parts, unsuitable attachments, or the unauthorized alteration of any part.

This warranty does not cover replacement of expendable maintenance items made in connection with required maintenance services after the item's first scheduled replacement as listed in the maintenance section of the product owner's manual, such as: spark plugs and filters.

Disclaimer of Consequential Damage and Limitation of Implied Warranties:

American Honda Motor Co., Inc. and Honda Canada Inc. disclaim any responsibility for incidental or consequential damages such as loss of time or the use of the power equipment, or any commercial loss due to the failure of the equipment; and any implied warranties are limited to the duration of this written warranty. This warranty is applicable only where the California, U.S. EPA or Environment Canada Emission Control System Warranty regulation is in effect.

Emission Control System Warranty Parts:

SYSTEMS COVERED BY THIS WARRANTY:	PARTS DESCRIPTION:
Fuel Metering	Carburetor assembly, (includes starting enrichment system), Engine temperature sensor, Engine control module, Fuel regulator, Intake manifold
Evaporative	Fuel hoses
Exhaust	Catalyst, Exhaust manifold
Air Induction	Air filter housing, Air filter element*, Crankcase breather tube
Ignition	Flywheel magneto, Ignition pulse generator, Crankshaft position sensor, Power coil, Ignition coil assembly, Ignition control module, Spark plug cap, Spark plug*
Miscellaneous Parts	Tubing, fittings, seals, gaskets, and clamps associated with these listed systems.

* Covered up to the first required replacement only. See the *Maintenance Schedule* on page 24.

TECHNICAL AND CONSUMER INFORMATION

Customer Service Information

Honda Power Equipment dealership personnel are trained professionals. They should be able to answer any question you may have. If you encounter a problem that your dealer does not solve to your satisfaction, please discuss it with the dealership's management. The Service Manager or General Manager can help. Almost all problems are solved in this way.

If you are dissatisfied with the decision made by the dealership's management, contact the Honda Power Equipment Customer Relations Office. You can write:

American Honda Motor Co., Inc.
Power Equipment Division
Customer Relations Office
4900 Marconi Drive
Alpharetta, GA 30005-8847

Or telephone: (770) 497-6400 M-F, 8:30 a.m. - 8:00 p.m. EST

- When you write or call, please give us this information:
- Model and serial numbers (page 47)
- Name of the dealer who sold the lawn mower to you
- Name and address of the dealer who services your lawn mower
- Date of purchase
- Your name, address, and telephone number
- A detailed description of the problem

A

Accessories warranty	58
Air cleaner service	31
Air index	52
Altitude, high altitude operation	48
Assembly	44

B

Blade	
Installation	27
Removal	26
Wear	25
Blade control system	9

C

Carburetor	
Draining	39
Modifications for altitude	48
Choke operation	15
Cleaning	
Engine	37
Grass bag	37
Mower deck	37
Clogged mower deck	21
Customer relations	62
Cutting height	
Adjustment	10
Recommendations	19

D

Dealer locator information	55
Distributor's warranty	57
Drive problems	43

E

Emissions	
Control system	50
Warranty	59
Engine specifications	53
Ethanol oxygenated fuel	49

F

Fuel	
Oxygenated	49
Recommendations	36
Refueling	35
Stabilizer additive	38
Valve location	8
Fuel tank draining	39

G

Grass bag	
Assembly	45
Cleaning or replacement	28
Inspection	14

I

Introduction	1
--------------	---

L

Loading and unloading	41
-----------------------	----

M

Maintenance	
Safety	23
Schedule	24
Specifications	53
Methanol oxygenated fuel	49
MTBE oxygenated fuel	49
Mulching plug	13

N

NOTICE symbol	1
---------------	---

O

Oil	
Change	30
Check level	29
Recommendations	29
Oxygenated fuels	49

INDEX

P

Parts

Catalog	55
Emissions	52
Publications	55

R

Replacement parts	56
-------------------------	----

S

Safety

A few words	2
Labels	2
Maintenance	23
Mower	4
Serial number locations	47
Shop manual ordering	55
Smart Drive	
Cable adjust	34
Control	9
Spark arrester service	33
Spark plug	32
Specifications	53
Starting the engine	15

Stopping the engine	17
---------------------------	----

T

Technical information	47
Throttle lever	8
Transporting	41
Troubleshooting	
Engine and vibration	43
Mowing and bagging	43

U

Unloading	41
-----------------	----

V

Variable speed thumb control ..	17
---------------------------------	----

W

Warranty

Accessories & parts	58
Distributor's	57
Emissions	59
Service information	62
Washing the mower	37
Web address	55

QUICK REFERENCE INFORMATION

Fuel	Type	Unleaded gasoline with a pump octane rating of 86 or higher (page 36)
Engine oil	Type	SAE 10W-30, API SJ or later (page 29)
Spark plug	Type	Regular: NGK BP6ES DENSO W20EP-U Resistor: NGK BPR6ES DENSO W20EPR-U
Maintenance	Before each use	Check condition of blades (page 25) Check torque of blade bolts (page 27) Check condition of grass bag (page 14) Check level of engine oil (page 29) Check condition of air cleaner (page 31)
	After initial 20 hours	Change engine oil (page 30)
	Subsequent	Refer to the Maintenance Schedule (page 24)

HONDA

The Power of Dreams

31VL0B01
00X31-VL0-B010



EM4 **K3**
POM53850-A
IPC 50000.2006.03
PRINTED IN U.S.A.