

**HONDA**

**Power**

**Equipment**

# Owner's Manual

## Rotary Mower

### HRA215SXA

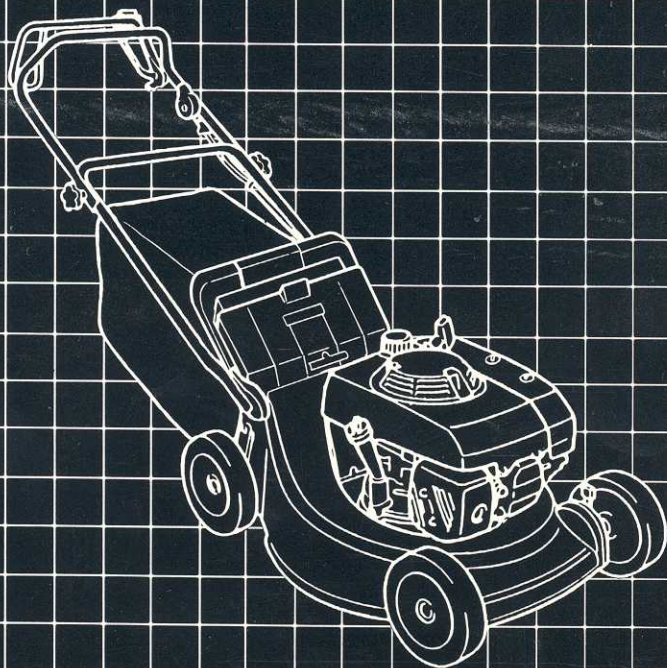







---

Thank you for purchasing a Honda rotary mower.

This manual describes operation and maintenance of Honda HRA215 rotary mowers. All information in this publication is based on the latest product information available at the time of printing. Honda Power Equipment Mfg., Inc. reserves the right to make changes at any time without notice and without incurring any obligation.

No part of this publication may be reproduced without written permission.

This manual is a permanent part of the mower and must remain with the mower if resold.

Honda HRA215 mowers meet CPSC blade safety requirements for walk-behind rotary mowers.

Honda HRA215 mowers are not factory-equipped with spark arresters. In some areas, it is illegal to operate an engine without a USDA qualified spark arrester. Check local laws and regulations before operation. An optional spark arrester is available from authorized Honda lawn mower dealers.

READ THIS OWNER'S MANUAL CAREFULLY. Pay special attention to these symbols and any instructions that follow:

**⚠ DANGER** Indicates serious injury or death **WILL** result if instructions are not followed.

**⚠ WARNING** Indicates a strong possibility that serious injury or death may result if instructions are not followed.

**⚠ CAUTION** Indicates a possibility that minor injury could result if instructions are not followed.

**IMPORTANT NOTICE** Indicates that equipment or property damage could result if instructions are not followed.

NOTE: Gives helpful information.

Honda rotary mowers are designed to give safe and dependable service if operated according to instructions. Operating this mower requires special effort on your part to ensure your safety and the safety of others.

**⚠ WARNING** Careless operation or misuse may cause injury or property damage. Read and understand this owner's manual before operating the mower.

**⚠ WARNING** Using this product for a purpose not intended may cause injury or property damage. Use only for mowing (cutting) grass, and for bagging cut grass when equipped with the standard grass bag or optional hard-shell grass catcher.

If a problem should arise, or if you have any questions about your mower, see an authorized Honda lawn mower dealer.

# CONTENTS

---

1. SAFETY .....	3
Safety Label Locations .....	3
Safety Information .....	4
Important Message to Parents .....	6
2. COMPONENT IDENTIFICATION .....	7
3. CONTROLS .....	9
Fuel Valve .....	9
Throttle Lever .....	9
ROTO-STOP Lever .....	10
Drive Clutch Lever (HRA215SXA) .....	11
Shift Lever (HRA215SXA) .....	12
Handlebar Locking Knobs .....	12
Cutting Height Adjustment Levers .....	13
4. ATTACHMENTS .....	14
Grass Bag (standard) .....	14
Hard-Shell Grass Catcher (optional) .....	15
Side-Discharge Chute (optional) .....	15
5. PRE-OPERATION CHECK .....	16
Blade .....	16
Grass Bag .....	17
Optional Attachments .....	17
Engine Oil .....	18
Fuel .....	19
Air Cleaner .....	21
Cutting Height .....	22
6. OPERATION .....	23
Starting the Engine .....	23
Clearing a Flooded Engine .....	25
Mower Operation .....	26
Stopping the Engine .....	28
High Altitude Operation .....	29
7. MOWING RECOMMENDATIONS .....	30
8. TRANSPORTING .....	33
9. MAINTENANCE .....	35
Maintenance Schedule .....	35
Engine Oil Change .....	36
Air Cleaner Service .....	38
Spark Plug Service .....	40
Spark Arrester Maintenance (optional equipment) .....	41
ROTO-STOP Cable Adjustment .....	42
Drive Clutch Cable Adjustment (HRA215SXA) .....	43
Throttle Cable Adjustment .....	44
Carburetor Adjustment .....	45
Grass Bag Cleaning and Replacement .....	46
Blade Removal and Installation .....	47
10. STORAGE .....	49
Preparation for Storage .....	49
Storage .....	51
Removal from Storage .....	52
11. TROUBLESHOOTING .....	53
12. SPECIFICATIONS .....	55
13. WIRING DIAGRAM .....	56
14. WARRANTY SERVICE .....	57

## SAFETY LABEL LOCATIONS

Read all safety instructions before operating the mower.

**⚠ WARNING**

**DO NOT START UNLESS REAR DOOR IS CLOSED OR BAG IS IN PLACE.**

- READ OWNER'S MANUAL BEFORE OPERATING.
- DISCONNECT THE SPARK PLUG CAP BEFORE CUTTER DECK AND CUTTER BLADE SERVICING.
- DO NOT ALLOW ANYONE TO STAND IN FRONT OF MOWER.
- TO PREVENT INJURY FROM THROWN OBJECTS: CLEAR AREA OF DEBRIS. KEEP OTHERS AWAY.
- TO PREVENT SERIOUS INJURY, DO NOT REACH INSIDE WHEN ENGINE IS RUNNING.
- DO NOT REMOVE GUARDS.



**DANGER | KEEP HANDS and FEET AWAY**

# 1. SAFETY

---

## SAFETY INFORMATION

For your safety and the safety of others, pay special attention to these precautions:

### Operator Responsibility

- Know how to stop the engine quickly in case of emergency. Understand the use of all controls.
- Be sure that anyone who operates the lawn mower receives proper instruction. Allowing anyone, especially children, to operate the mower without proper instruction may result in serious injury.
- Wear long pants and protective footwear. Operating the mower while barefoot or wearing sandals would increase the risk of injury.
- Keep all persons and pets away from the mowing area.

### Blade Hazards

The blade is sharp, and it turns at high speed. Accidental contact can cause serious injury.

- If the mower tilts or overturns, the blade will be exposed; that will increase the risk of injury from blade contact and from thrown objects.
- Keep your hands and feet away from the cutter deck while the engine is running.
- Stop the engine before adjusting cutting height, or performing any inspection or maintenance.
- Wear heavy gloves to protect your hands from the blade when cleaning out the mower deck, or when inspecting or replacing the blade. Disconnect the spark plug cap to prevent any possibility of accidental starting.

### Thrown Object Hazards

Objects hit by the blade can be thrown with great force. Thrown objects may cause serious injury or property damage.

- Before mowing, clear the lawn of sticks, stones, dog bones, and other litter and loose objects. Mow only in daylight, so you can see and avoid objects in the grass.
- Before starting the mower, be sure that the grass bag, grass catcher, or side-discharge chute is in place, or that the discharge guard is closed.
- Release the ROTO-STOP lever to stop the blade before reaching areas with gravel, loose stones, or landscaping material.
- Broken pieces thrown from a worn or damaged blade can cause serious injury. Always inspect the blade before using the mower.



## **Fire and Burn Hazards**

Gasoline is extremely flammable, and gasoline vapor can explode. Use extreme care when handling gasoline. **KEEP OUT OF REACH OF CHILDREN.**

- Refuel in a well-ventilated area with the engine stopped. Keep flames and sparks away, and do not smoke in the area.
- Refuel carefully to avoid spilling fuel. Avoid overfilling the fuel tank (there should be no fuel in the filler neck). After refueling, tighten the filler cap securely. If any fuel is spilled, make sure the area is dry before starting the engine.
- After use, turn the fuel valve OFF, and store the mower on a level surface. Be sure the storage area is well-ventilated, and away from appliances, such as water heaters and clothes dryers.

Dry grass and leaves are flammable.

- Always empty the grass bag when you've finished mowing, even if it's not full. Stored lawn clippings are a fire hazard.
- Honda HRA215 mowers are not factory-equipped with spark arresters. It is illegal in some areas to operate an engine without a USDA qualified spark arrester. Check local laws and regulations. An optional spark arrester is available from authorized Honda lawn mower dealers.

The engine and exhaust system become very hot during operation and remain hot for a while after stopping. Contact with hot engine components can cause burns and may ignite some materials.

- Avoid touching a hot engine or exhaust system.
- Allow the engine to cool before performing maintenance, transporting the mower, or storing the mower indoors.

## **Carbon Monoxide Poisoning Hazard**

Exhaust contains poisonous carbon monoxide, a colorless and odorless gas. Breathing exhaust can cause loss of consciousness and may lead to death.

- If you run the engine in an area that is confined, or even partially enclosed, the air can become contaminated with a dangerous amount of exhaust gas. To keep exhaust gas from building up, provide adequate ventilation.

# 1. SAFETY

---

## IMPORTANT MESSAGE TO PARENTS

YOUR CHILDREN'S SAFETY IS VERY IMPORTANT to Honda. That's why we urge you to read this message before letting your youngster operate this lawn mower. Lawn mowers are tools, not toys. As with any equipment, bad judgments can result in serious injuries. You can help prevent accidents by making good decisions about *if, when, and how* your youngster operates this equipment.

The first question you'll need to ask is whether your youngster is capable of operating this mower safely. Remember, young people vary widely, and **AGE IS NOT THE ONLY FACTOR.**

Physically, a youngster must be **LARGE ENOUGH AND STRONG ENOUGH** to easily start the mower and control its direction. The youngster also needs enough size, strength, and coordination to comfortably reach and operate the controls.

Another, tougher question you need to ask is if your youngster has enough **MATURITY AND RESPONSIBILITY** to safely operate this mower. Does the young person think through problems and come to logical solutions? Be honest! Anyone who takes unnecessary risks and doesn't obey rules should not operate this lawn mower.

If you decide that your son or daughter can handle the mower safely, **CAREFULLY READ THE OWNER'S MANUAL** with your youngster. Make sure you both understand all instructions and warnings. Also, be sure your youngster wears sturdy shoes and other protective clothing when operating or handling the mower.

**SUPERVISION** is also very important. Walk with your youngster during the first few minutes of mowing. Even after the youngster has become confident with the mower, do not let the young person use the mower without good adult supervision. An adult should also be present during refueling and maintenance. In fact, it's up to parents to make sure that the mower is properly maintained and kept in safe operating condition.

By always placing safety first, your youngster will acquire useful skills and a sense of accomplishment. And you'll both get the best results from your lawn mower.

## 2. COMPONENT IDENTIFICATION

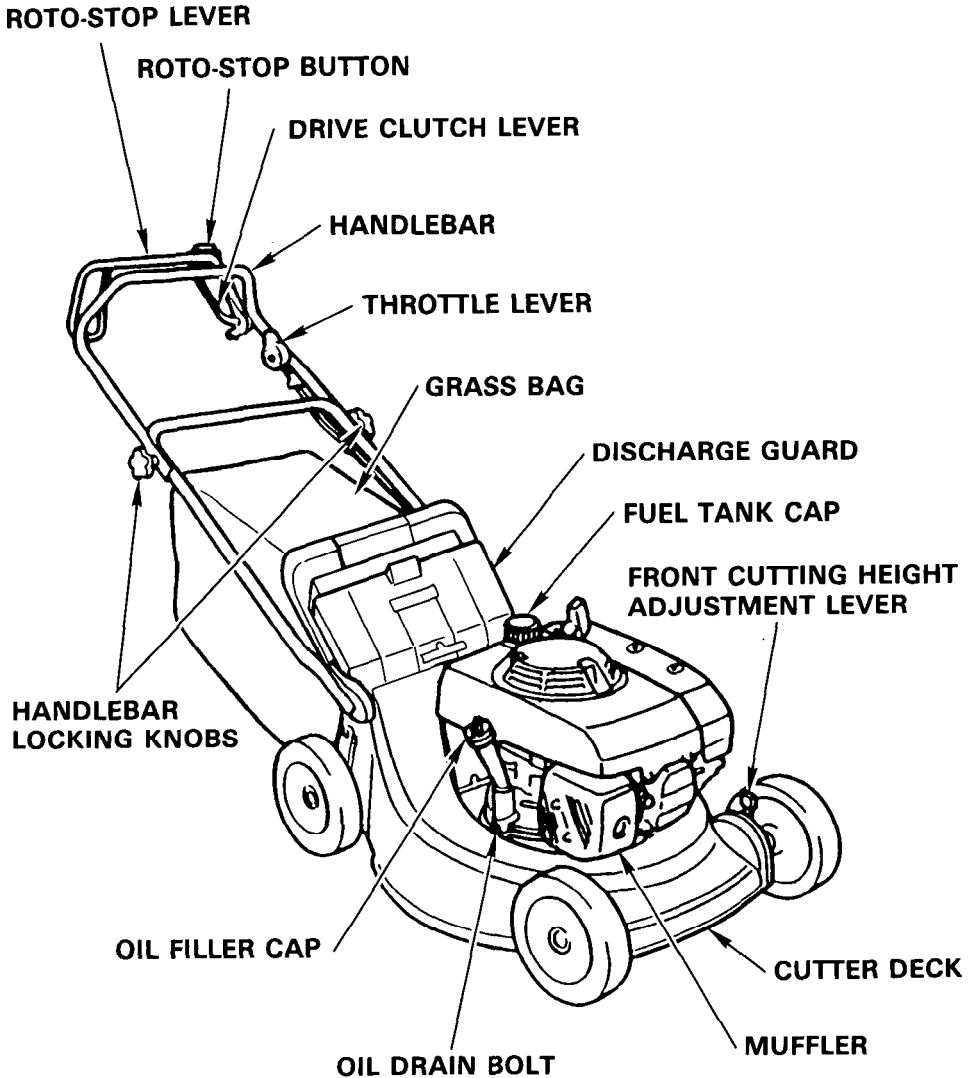

HRA215SXA: Manual starting; self-propelled

## 2. COMPONENT IDENTIFICATION

---

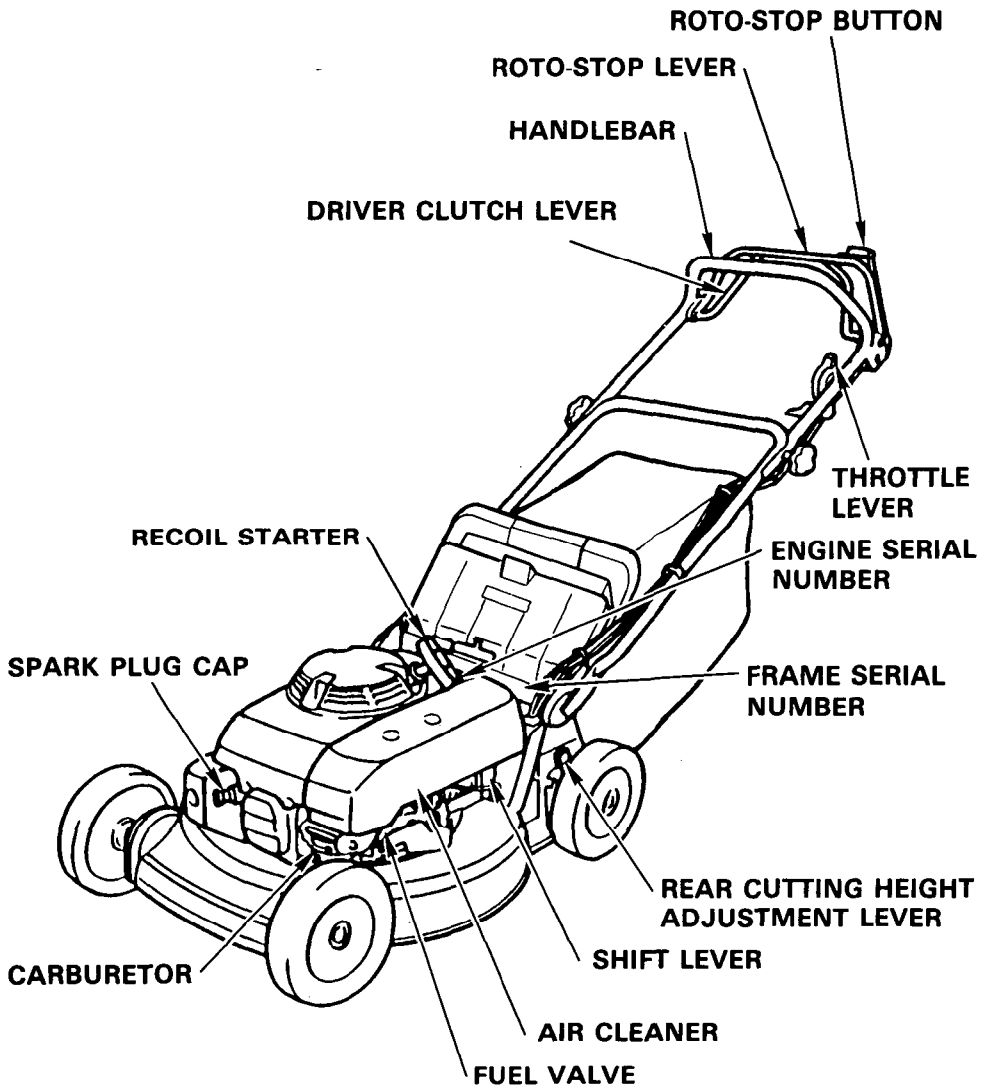

Record the frame and engine serial numbers for your reference. Refer to the serial numbers when ordering parts, and when making technical or warranty inquiries (see page 57).

Frame serial number: \_\_\_\_\_

Engine serial number: GXV140- \_\_\_\_\_

# 3. CONTROLS

## FUEL VALVE

The fuel valve opens and closes the connection between the fuel tank and the carburetor.

The fuel valve must be in the ON position for the engine to run.

When the mower is not in use, turn the fuel valve to the OFF position to prevent the possibility of carburetor flooding, and to reduce the possibility of fuel leakage.

**⚠ WARNING** Gasoline is extremely flammable, and gasoline vapor can explode, causing injury or death. Turn the fuel valve to the OFF position when the mower is not in use.

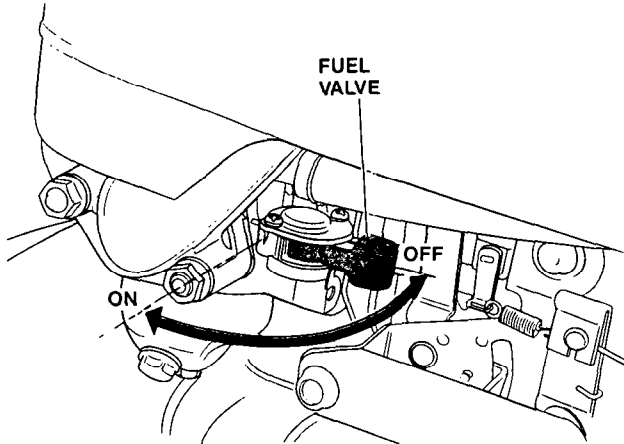

## THROTTLE LEVER

CHOKE position: For starting

FAST position (  ): For mowing

SLOW position (  ): For idling

STOP position: Stops the engine

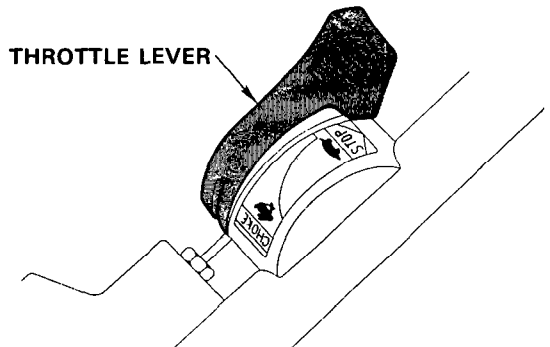

### 3. CONTROLS

---

#### ROTO-STOP LEVER

The ROTO-STOP lever operates the blade brake/clutch mechanism. It is used to start and stop the blade.

To put the blade into operation, press the button on top of the ROTO-STOP lever, then push the lever forward and hold it against the handlebar.

Releasing the ROTO-STOP lever will stop the blade.

Operate the ROTO-STOP lever with a quick and complete motion, so the blade drive is always either fully engaged or stopped. This will help to prevent stalling the engine, and it will also extend the service life of the ROTO-STOP mechanism.

**IMPORTANT NOTICE** If you move the ROTO-STOP lever slowly or partially, the blade brake/clutch mechanism will wear out prematurely.

**NOTE:** Always release the ROTO-STOP lever before starting the engine. If the blade drive is engaged, extra effort will be required to operate the starter.

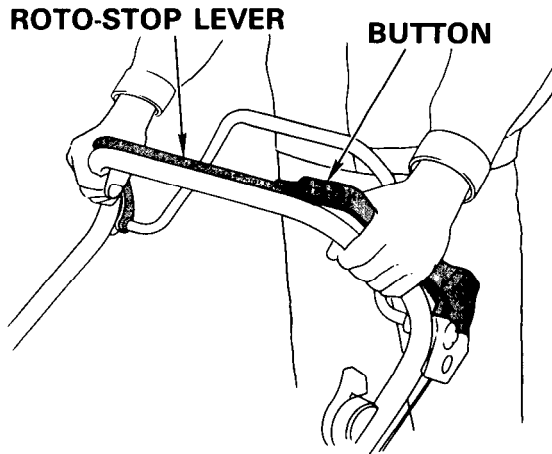

### DRIVE CLUTCH LEVER (HRA215SXA)

This lever operates the clutch to drive the rear wheels that propel the mower.

To propel the mower, push the drive clutch lever forward and hold it against the handlebar. Release the lever to disengage the drive.

To propel the mower and operate the blade at the same time, press the button on top of the ROTO-STOP lever, push the ROTO-STOP lever forward, then push the drive clutch lever forward.

**NOTE:** Always release the drive clutch lever before starting the engine. If the drive clutch is engaged, the mower will move forward when you operate the starter.

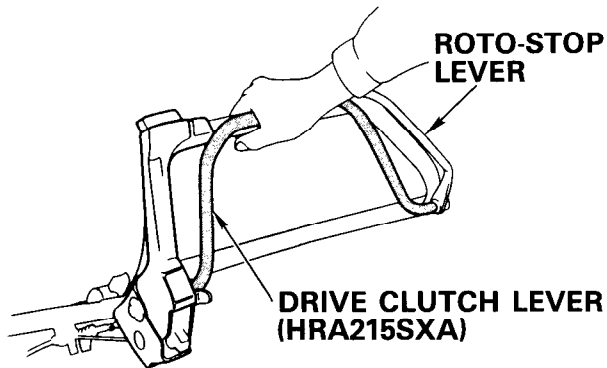

# 3. CONTROLS

---

## SHIFT LEVER

The shift lever selects the drive speed for the mower. Move the shift lever to select the pace at which you wish to mow.

### NOTE:

- The mower will lurch if you shift gears while the drive clutch is engaged. Release the drive clutch lever before moving the shift lever.
- To avoid incomplete gear engagement, be sure the shift lever is centered in one of the three detent positions.

Position 1: SLOW; 2.6 ft/sec (0.8 m/sec) maximum speed

Position 2: MEDIUM; 3.9 ft/sec (1.2 m/sec) maximum speed

Position 3: FAST; 4.6 ft/sec (1.4 m/sec) maximum speed

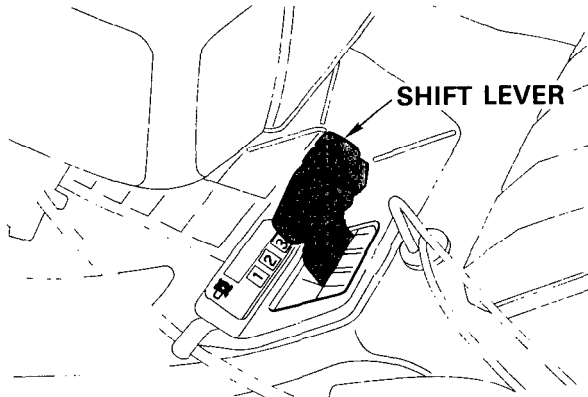

## HANDLEBAR LOCKING KNOBS

The handlebar locking knobs must be tightened to secure the handlebar in the mowing position. These knobs can be loosened to fold the handlebar for storage or transport convenience (see page 52).

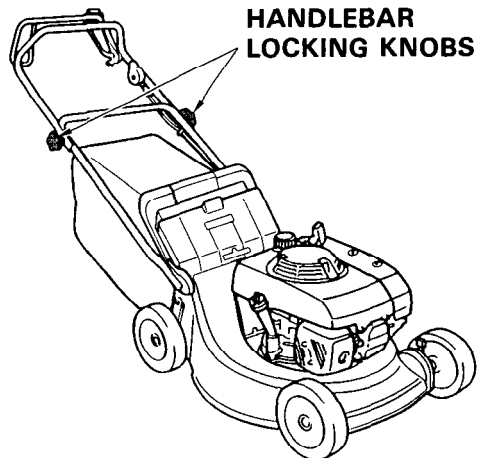



## CUTTING HEIGHT ADJUSTMENT LEVERS

**⚠ WARNING** The blade can cause serious injury. Stop the engine before adjusting cutting height.

There are five cutting height settings: 1 in (2.7 cm), 1-1/2 in (4.0 cm), 2 in (5.2 cm), 2-1/2 in (6.4 cm), and 3 in (7.6 cm). These are approximate figures, as the actual height of cut grass will vary with lawn and soil conditions.

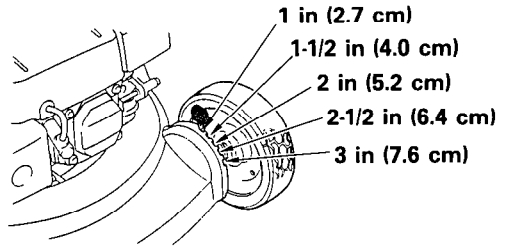

To adjust cutting height, pull each adjusting lever toward the wheel, and move it into another notch. Set both adjusting levers to the same cutting height position.

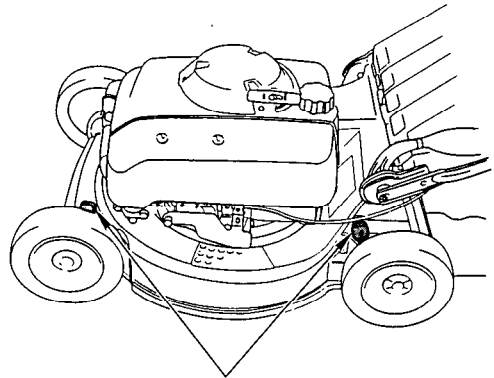

**ADJUSTING LEVERS**

Select the correct cutting height for your mowing requirements. Cutting height settings of 1-1/2 in (4.0 cm) or 2 in (5.2 cm) are appropriate for most lawns during cool weather. A higher cut may be needed to protect the lawn during hot summer months. Consult a local nursery or lawn & garden center for advice about specific types of grasses and growing conditions in your area.

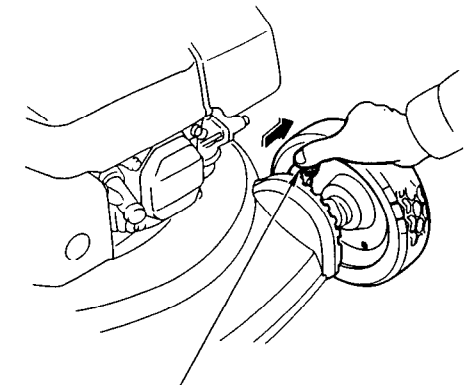

**ADJUSTING LEVER**

If you are not certain which cutting height to select, check the appearance of the lawn after mowing a small area, then readjust cutting height if necessary.

## 4. ATTACHMENTS

---

Honda HRA215 mowers are provided with a grass bag as standard equipment. You can operate the mower with the grass bag (or optional hard-shell grass catcher) installed to collect the grass clippings, or with the grass bag removed (or optional side-discharge chute installed) if you wish to leave the grass clippings on the lawn. When attachments are removed, the discharge guard automatically closes to protect the operator from objects that may be thrown by the blade.

### NOTE:

- When mowing without attachments, the closed discharge guard will trap more grass under the cutter deck, and the cutter deck may clog when mowing grass that is thick or tall. If clogging occurs, mow more frequently, cut a narrower swath, and/or select a slower drive speed. You may also need to raise the mower's cutting height.
- If you wish to leave the grass clippings on the lawn, we recommend using the optional, side discharge chute (see page 15).

### GRASS BAG (standard equipment)

#### Installation

1. Raise the discharge guard, and hook the grass bag onto the mower as shown.
2. Release the discharge guard.

#### Removal

1. Raise the discharge guard, grab the handle of the grass bag lid, and remove the bag.
2. Release the discharge guard.

NOTE: When the bag is clear of the discharge guard, you can lift it through the handlebar opening, or you can remove it to the rear of the mower below the handlebar.

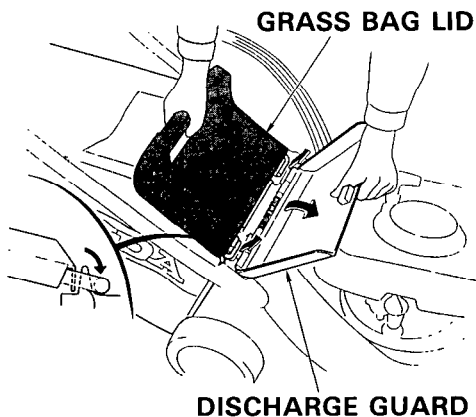

## 4. ATTACHMENTS

A hard-shell grass catcher, and a side-discharge chute, are available from authorized Honda lawn mower dealers. They attach to the cutter deck in place of the standard grass bag.

### HARD-SHELL GRASS CATCHER (optional)

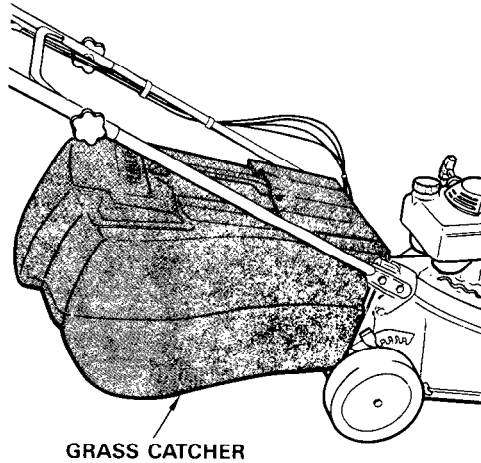

### SIDE-DISCHARGE CHUTE (optional)

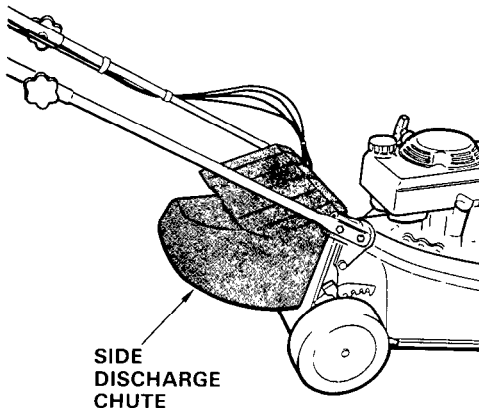

# 5. PRE-OPERATION CHECK

Check the following items before starting the engine.

## BLADE

Turn the fuel valve OFF, and tilt the mower to the right, so the carburetor side is up.

NOTE: Hard starting and fuel leakage may result if the mower is tilted with the carburetor side down.

Inspect the blade for wear and damage.

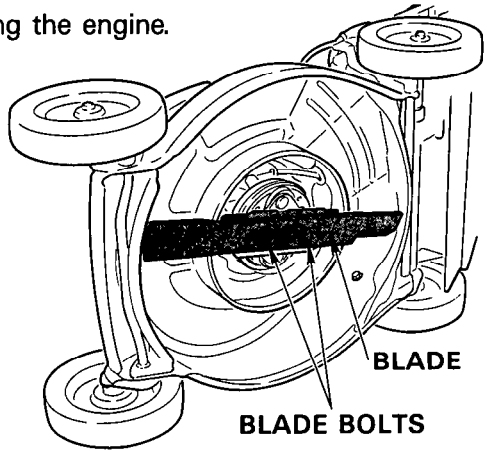

NORMAL



EXCESSIVELY WORN



BENT



CRACKED

A dull blade can be sharpened, but a blade that is worn out, bent, cracked, or otherwise damaged must be replaced. A worn or damaged blade could break, causing pieces of the blade to be thrown from the mower.

**⚠ WARNING** A worn or damaged blade may cause serious injury. Always inspect the blade before using the mower.

When the blade needs sharpening or replacement, take the lawn mower to an authorized Honda lawn mower dealer. Or, if you have a torque wrench, you can remove and install the blade yourself (see page 47).

- Blade sharpening: To avoid weakening the blade, or causing imbalance or poor cutting, the blade should be sharpened by an authorized Honda lawn mower dealer.
- Blade replacement: Use a genuine Honda replacement blade or its equivalent.

Check that the blade bolts are tight. Be sure the ROTO-STOP lever is released, so the blade will not move when tightening the bolts. Wear heavy gloves to protect your hands. Blade bolt torque: 36.2–43.4 ft lb (5.0–6.0 kg-m).

## 5. PRE-OPERATION CHECK

### GRASS BAG

Check that the grass bag is in good condition and not clogged.

A clogged grass bag will not collect grass efficiently. When the bag needs cleaning, wash it with a garden hose, and allow it to dry thoroughly before use; a wet bag will clog quickly.

The grass bag wears during normal use and will eventually require replacement. If you operate the mower with a damaged or worn out bag, objects picked up by the blade may be thrown through the bag material.

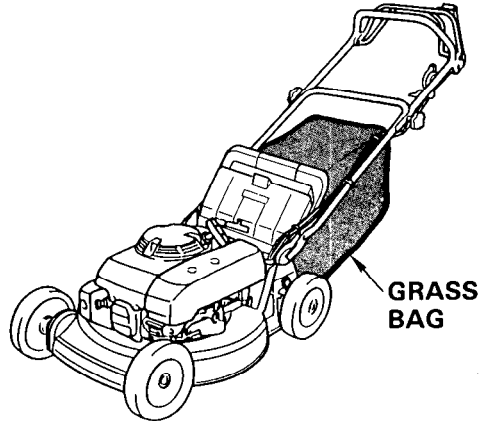

**⚠ WARNING** Objects thrown through a worn or damaged grass bag may cause serious injury. Install a new grass bag when required.

### OPTIONAL ATTACHMENTS

If you have the hard-shell grass catcher, or the side-discharge chute (page 15), check those attachments to be sure they are in good condition. Operating the mower with a damaged attachment will increase risk of injury from objects thrown by the blade.

**⚠ WARNING** Objects thrown by the blade may cause serious injury. Replace damaged attachments before using the mower.

Check that the screws are tight in the hard-shell grass catcher, and that the screen at the back of the unit is not clogged. The screen must be cleaned occasionally to maintain grass-bagging efficiency.

# 5. PRE-OPERATION CHECK

## ENGINE OIL

Check the engine oil level with the engine stopped and the mower on a level surface.

1. Remove the oil filler cap, and wipe the dipstick clean.
2. Insert the dipstick into the oil filler neck, but do not screw it in.
3. Check the oil level shown on the dipstick. If near the lower level, fill to the upper level with the recommended oil.

**IMPORTANT NOTICE** Running the engine with a low oil level will cause engine damage.

Use high-detergent, premium quality 4-stroke engine oil, certified to meet or exceed U.S. automobile manufacturers' requirements for API Service Classification SG, SF/CC, CD.

**IMPORTANT NOTICE** Using non-detergent oil can shorten the engine's service life, and using 2-stroke oil will damage the engine.

SAE 10W-30 is recommended for general, all-temperature use. Other viscosities shown in the chart may be used when the average temperature in your area is within the indicated range.

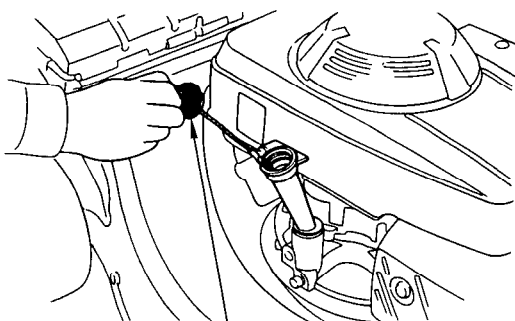
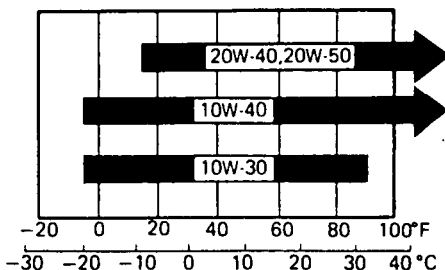

FILLER CAP/DIPSTICK

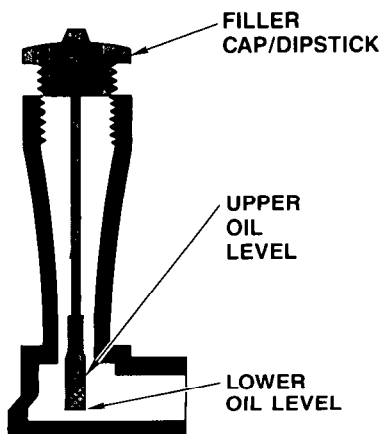

FILLER CAP/DIPSTICK

UPPER OIL LEVEL

LOWER OIL LEVEL

## 5. PRE-OPERATION CHECK

### FUEL

Fuel tank capacity: 0.26 US gal (1.0 ℓ)

Remove the filler cap and check the fuel level. Refill the tank if the fuel level is low. Refuel carefully to avoid overfilling or spilling fuel. There should be no fuel in the filler neck.

**⚠ WARNING** Gasoline is extremely flammable, and gasoline vapor can explode, causing serious injury or death. Use extreme care when handling gasoline. KEEP OUT OF REACH OF CHILDREN.

Refuel in a well-ventilated area with the engine stopped. Do not smoke or allow flames or sparks in the area where the engine is refueled or where gasoline is stored. Avoid repeated or prolonged contact with skin or breathing of vapor.

After refueling, tighten the fuel tank cap securely. If any fuel was spilled, make sure the area is dry before starting the engine.

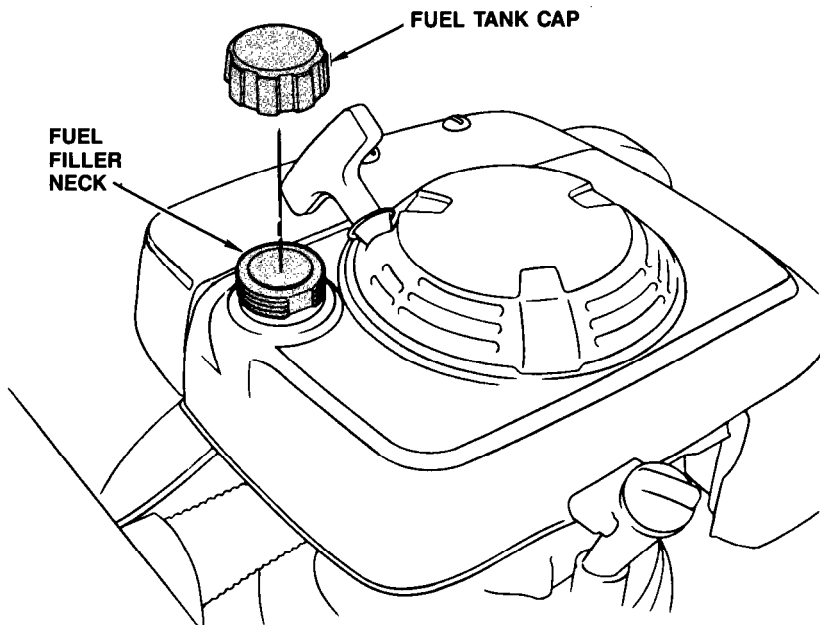

## 5. PRE-OPERATION CHECK

---

### Fuel Recommendation

**Pump octane rating: 86 or higher.**

We recommend unleaded fuel because it produces fewer engine and spark plug deposits and extends exhaust system life.

Never use stale or contaminated gasoline or an oil/gasoline mixture. Avoid getting dirt or water in the fuel tank.

Occasionally you may hear light “spark knock” or “pinging” (metallic rapping noise) while operating under heavy loads. This is no cause for concern.

If spark knock or pinging occurs at a steady engine speed, under normal load, change brands of gasoline. If spark knock or pinging persists, see an authorized Honda lawn mower dealer.

**IMPORTANT NOTICE** Running the engine with persistent spark knock or pinging can cause engine damage.

NOTE: Running the engine with persistent spark knock or pinging is considered misuse, and the Distributor’s Limited Warranty does not cover parts damaged by misuse.

### GASOLINES CONTAINING ALCOHOL

If you decide to use a gasoline containing alcohol (gasohol), be sure its pump octane rating is 86 or higher. There are two types of “gasohol”: one containing ethanol, and the other containing methanol.

**IMPORTANT NOTICE** Using gasohol that contains more than 10% ethanol, or gasoline containing methanol (methyl or wood alcohol) that does not also contain cosolvents and corrosion inhibitors for methanol, can cause serious fuel system damage and poor engine performance.

Never use gasoline containing more than 5% methanol, even if it has cosolvents and corrosion inhibitors.

Honda does not endorse the use of fuels containing methanol, since evidence of their suitability is as yet incomplete.

NOTE: Fuel system damage, or engine performance problems resulting from the use of fuels that contain alcohol, is not covered under the warranty.

Before buying fuel from an unfamiliar station, first determine if the fuel contains alcohol; if it does, find out the type and percentage of alcohol used.

NOTE: If you notice any undesirable operating symptoms while using a gasoline that contains alcohol, or one that you think contains alcohol, switch to a gasoline that you know does not contain alcohol.



## 5. PRE-OPERATION CHECK

### AIR CLEANER

Check that the air filter is clean and in good condition. A dirty air filter will restrict air flow to the carburetor, reducing engine performance. A damaged air filter will allow dirt to enter to engine, causing rapid engine wear.

1. Remove the cover screws, then remove the air cleaner cover.
2. Inspect the paper and foam elements of the air filter. Replace the filter if either of the filter elements are damaged. Clean or replace the filter if the filter elements are dirty. See page 38 for cleaning instructions.
3. Reinstall the air filter and air cleaner cover. Tighten the cover screws securely.

**IMPORTANT NOTICE** Operating the engine with no air filter, or a damaged air filter, will cause rapid engine wear.

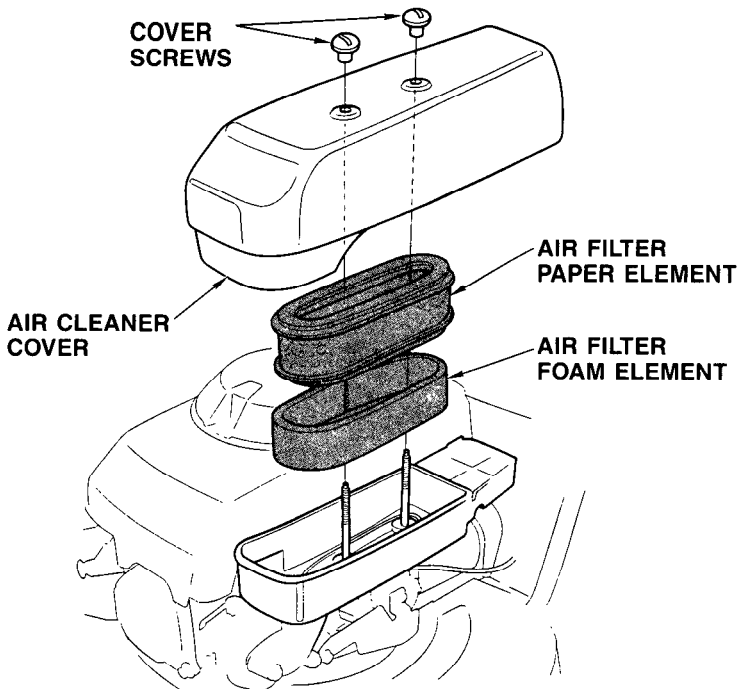

## 5. PRE-OPERATION CHECK

---

### CUTTING HEIGHT

Check the cutting height settings, and make any necessary adjustments (see page 13). Set both adjusting levers to the same cutting height position.

**⚠ WARNING** The blade can cause serious injury. Stop the engine before adjusting cutting height.

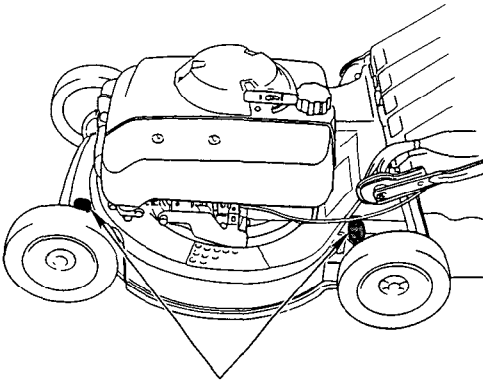

ADJUSTING LEVERS

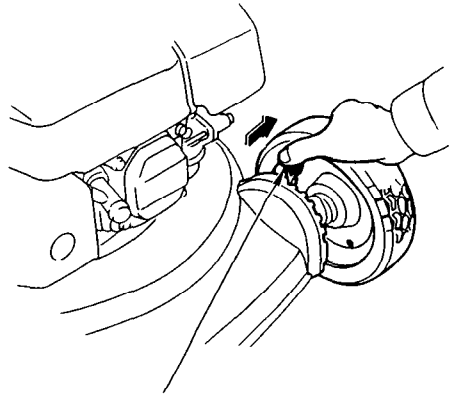

ADJUSTING LEVER

### STARTING THE ENGINE

If you run the engine in an area that is confined, or even partially enclosed, the air can become contaminated with a dangerous amount of exhaust gas.

**⚠ WARNING** Exhaust contains poisonous carbon monoxide, a colorless and odorless gas. Breathing exhaust can cause loss of consciousness and may lead to death. To keep exhaust gas from building up, provide adequate ventilation.

1. Turn the fuel valve to the ON position.
2. FOR STARTING A COLD ENGINE: Move the throttle lever to the CHOKE position.

FOR RESTARTING A WARM ENGINE: Move the throttle lever to the FAST (  ) position.

**NOTE:** Use the CHOKE position, unless the engine was recently running and is still thoroughly warm. If thoroughly warm, the engine will start easier using the FAST position.

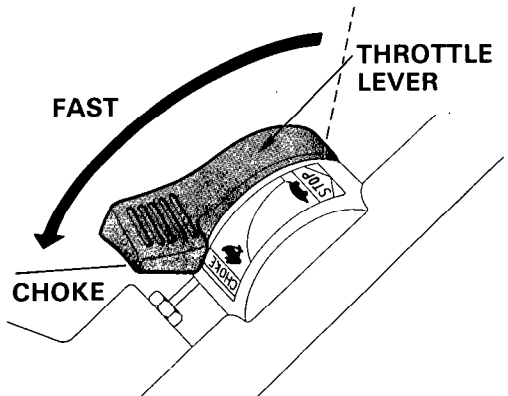
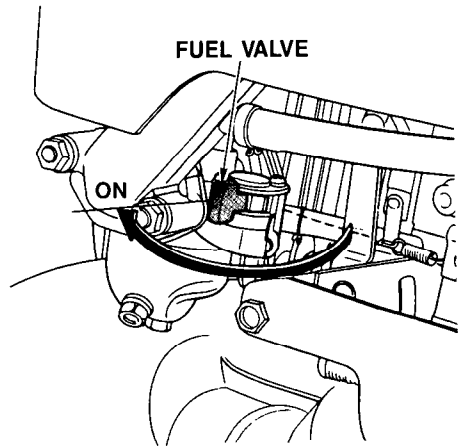

## 6. OPERATION

---

### 3. Operate the starter.

#### NOTE:

- Always release the ROTO-STOP lever before starting the engine. If the blade drive is engaged, extra effort will be required to operate the starter.
- HRA215SXA: Always release the drive clutch lever before starting the engine. If the drive clutch is engaged, the mower will move forward when you operate the starter.



Place your foot on the step of the cutter deck. Pull the starter grip lightly until you feel resistance, then pull briskly.

When the engine starts, return the starter rope gently.

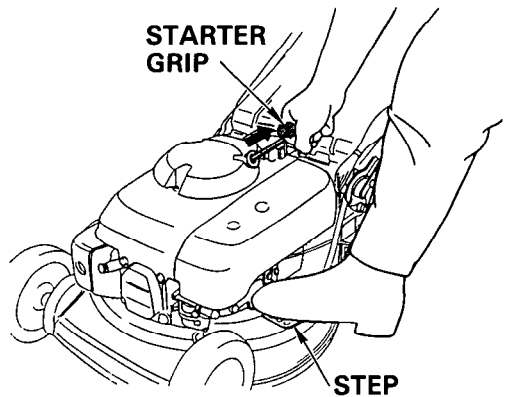
**IMPORTANT NOTICE** If you let the starter grip snap back against the engine, it may damage the starter.



## 6. OPERATION

- When the engine warms up, move the throttle lever away from the CHOKE position. Set the lever in FAST (  ) position for mowing, or in SLOW (  ) position for idling.

**NOTE:** If restarting a warm engine in the CHOKE position, move the throttle lever away from CHOKE as soon as the engine starts.

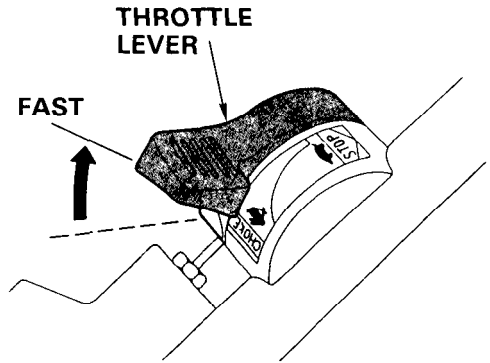



### CLEARING A FLOODED ENGINE

If the engine won't start, after you have operated the starter several times, the engine may be flooded with excess fuel. Use the following procedure to clear and start a flooded engine:

- Move the throttle lever to STOP, and turn the fuel valve OFF.
- Remove the spark plug, dry it, then reinstall it.

**NOTE:** Install the spark plug carefully, by hand, to avoid cross-threading. After the spark plug is seated, tighten 1/8 to 1/4 turn with a spark plug wrench to compress the washer.

- Turn the fuel valve ON, and move the throttle lever to FAST (  ).
- Operate the starter with the throttle lever in the FAST (  ) position.

# 6. OPERATION

## MOWER OPERATION

To mow, set the throttle lever in the FAST (  ) position, press the button on top of the ROTO-STOP lever, then move the ROTO-STOP lever forward and hold it against the handlebar. The blade will operate while the ROTO-STOP lever is held forward.

**NOTE:** For best grass cutting and bagging performance, and to avoid stalling the engine, always mow with the throttle lever in the FAST (  ) position.

Release the ROTO-STOP lever to stop the blade before reaching areas with gravel, loose stones, or landscaping material. Objects hit by the blade can be thrown with great force.

**⚠ WARNING** Thrown objects may cause serious injury and property damage. Stop the blade before reaching any area with loose objects.

Operate the ROTO-STOP lever with a quick and complete motion, so the blade is always either fully engaged or disengaged. This will help to prevent stalling the engine, and it will also extend the service life of the ROTO-STOP mechanism.

**IMPORTANT NOTICE** If you move the ROTO-STOP lever slowly or partially, the blade brake/clutch mechanism will wear out prematurely.

To propel the mower (HRA215SXA), push the drive clutch lever forward and hold it against the handlebar. Release the drive clutch lever to disengage the drive.

Hold the ROTO-STOP lever forward with the drive clutch lever for self-propelled mowing in open areas.

When mowing around trees and other obstacles, release the drive clutch lever (HRA215SXA) while holding the ROTO-STOP lever forward. Push the mower for better directional control.

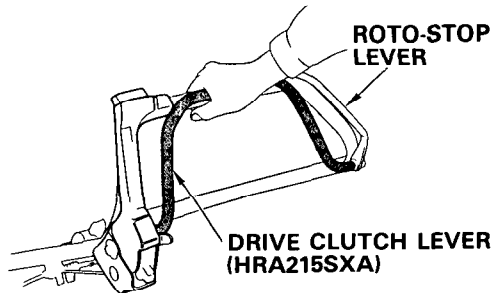
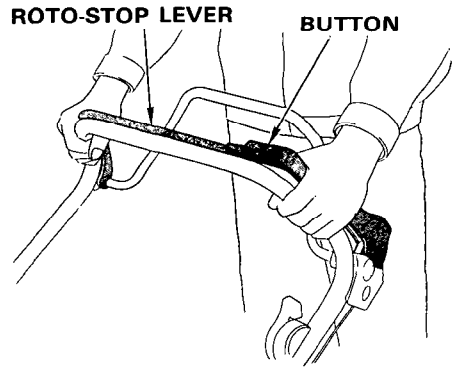
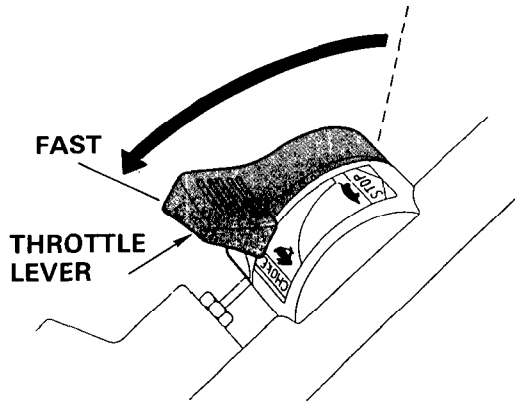

## 6. OPERATION

**⚠ WARNING** If the mower tilts or overturns, the blade will be exposed; that will increase the risk of injury from blade contact and from thrown objects and debris. For your safety, keep all four wheels on the ground, and be careful not to lose your footing and your control of the mower.

Keep a firm grip on the handlebar, and walk, never run, with the mower. Be very careful when mowing uneven or rough ground. Mow across slopes, never up and down. Be careful when changing the direction of the mower on a slope. Do not use the mower on a steep slope of more than 20°.

MAXIMUM SLOPE: 20°

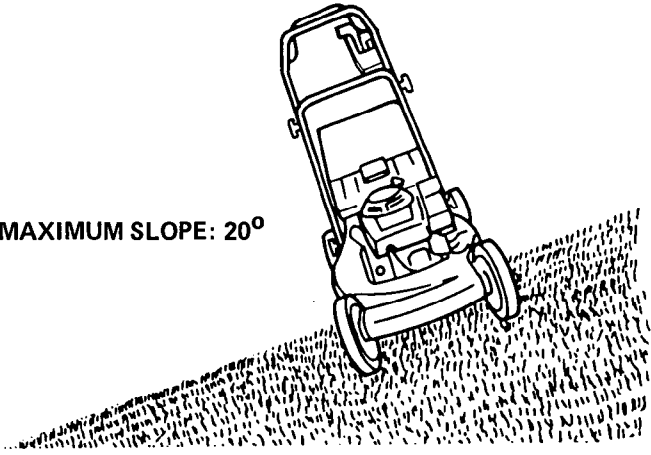

Use extra care when mowing over objects imbedded in the lawn, such as sprinkler heads, paving, edging, etc. Avoid anything that sticks up above the surface of the lawn. Striking objects may damage the blade, bend the crankshaft, and/or break the cutter deck or other mower components.

**⚠ WARNING** A damaged blade may break. Broken pieces can be thrown by the blade and may cause serious injury. Stop the engine immediately if you suspect the blade is damaged.

If the blade hits something, or if the mower starts to vibrate, follow these steps:

1. Stop the engine.
2. Inspect the blade and other mower components for damage.
3. Replace any damaged parts before operating the mower.

**NOTE:** The Distributor's Limited Warranty does not cover parts damaged by accident or collision.

## 6. OPERATION

---

### STOPPING THE ENGINE

1. Release the drive clutch lever (HRA215SXA) and ROTO-STOP lever (all models).
2. Move the throttle lever to the STOP position.

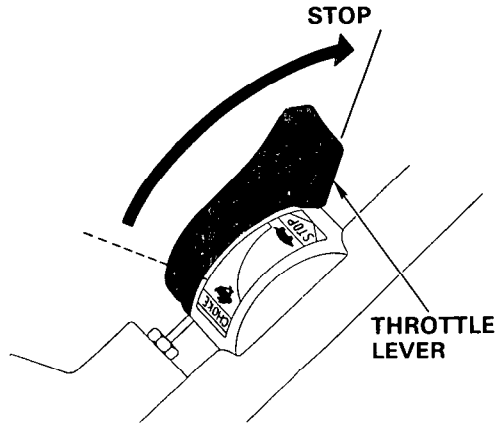

When the mower is not in use, turn the fuel valve to the OFF position to prevent the possibility of carburetor flooding, and to reduce the possibility of fuel leakage.

**⚠ WARNING** Gasoline is extremely flammable, and gasoline vapor can explode, causing injury or death. Turn the fuel valve to the OFF position when the mower is not in use.

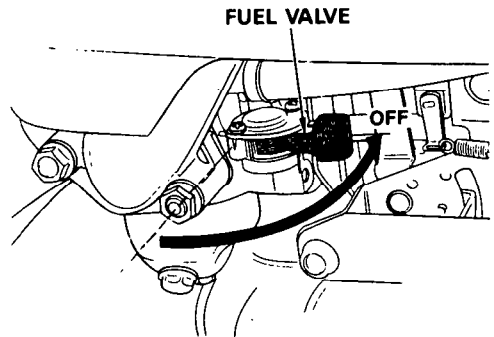



### HIGH ALTITUDE OPERATION

At high altitude, the standard carburetor air-fuel mixture will be too rich. Performance will decrease, and fuel consumption will increase. A very rich mixture may also foul the spark plug and cause hard starting.

High altitude performance can be improved by installing a smaller diameter main fuel jet in the carburetor and readjusting the pilot screw. If you always operate the mower at altitudes higher than 6,000 feet above sea level, have an authorized Honda lawn mower dealer perform this carburetor modification.

Even with carburetor modification, engine horsepower will decrease about 3.5% for each 1,000 foot increase in altitude. The effect of altitude on horsepower will be greater than this if no carburetor modification is made. A reduction in engine horsepower will reduce mowing performance.

When the carburetor is modified for good high altitude operation, the air/fuel mixture will be too lean at low altitude. Performance will decrease, and the engine will overheat.

To avoid an excessively lean air/fuel mixture, reinstall the standard main fuel jet and readjust the pilot screw for operation at altitudes lower than 6,000 feet above sea level.

## 7. MOWING RECOMMENDATIONS

---

A cutting height of 1-1/2 in (4.0 cm) or 2 in (5.2 cm) is appropriate for most lawns during cool weather. A higher cut may be needed to protect the lawn during hot summer months. Consult a local nursery or lawn & garden center for advice about specific types of grasses and growing conditions in your area.

Most grasses should be mowed when they have grown half an inch to an inch above the recommended height. If allowed to grow too tall, and then cut back to the stems, the grass may not recover well, and the lawn will have brown patches.

As a general rule, do not cut off more than a third of the total height of the grass in one mowing. If tall grass is reduced in height a little at a time, and is allowed to recover between mowings, the grass will be healthier, and the lawn mower will work better and will leave a better lawn finish.

For good mowing conditions, the grass should be relatively dry, but the ground should not be so dry that the mower stirs up a lot of dust. Too much dust will clog the carburetor air filter, reducing engine performance.

If dust is a problem, water your lawn the day before mowing, allowing the grass to dry while the soil remains moist.

Always wait for wet grass to dry. Wet grass may clog the cutter deck, and it does not bag well.

Grass clippings may be left on the lawn, or removed, whichever you prefer. Clippings return nutrients to the soil, but they don't look neat when left on the lawn. Heavy clumps of clippings should always be removed; grass must remain uncovered to grow properly.

If you wish to leave the grass clippings on the lawn, we recommend using the optional, side-discharge chute (see page 15).

Mowing without the grass bag or other attachments will leave the grass clippings on the lawn, but the closed discharge guard will trap more grass under the cutter deck, and the cutter deck may clog when mowing grass that is thick or tall. If clogging occurs, mow more frequently, cut a narrower swath, and/or use a slower forward speed. You may also need to raise the mower's cutting height.

If you must clean out a clogged cutter deck, turn the fuel valve OFF, and tilt the mower so the carburetor side is up. Hard starting and fuel leakage may result if the mower is tilted with the carburetor side down.

## 7. MOWING RECOMMENDATIONS

For best results, start at the outer edges of the lawn, and work toward the center in a clockwise direction.

If you use the standard grass bag, or the optional hard-shell grass catcher, a clockwise mowing pattern, starting at the outer edges of the lawn, will give the best bagging performance, leaving the least amount of clippings on the lawn. The mower will bag most efficiently with this mowing pattern, due to cutter deck design and the direction in which the blade rotates.

If you use the optional side-discharge chute, use the same clockwise mowing pattern. This will prevent clippings from piling up in the path of the mower.

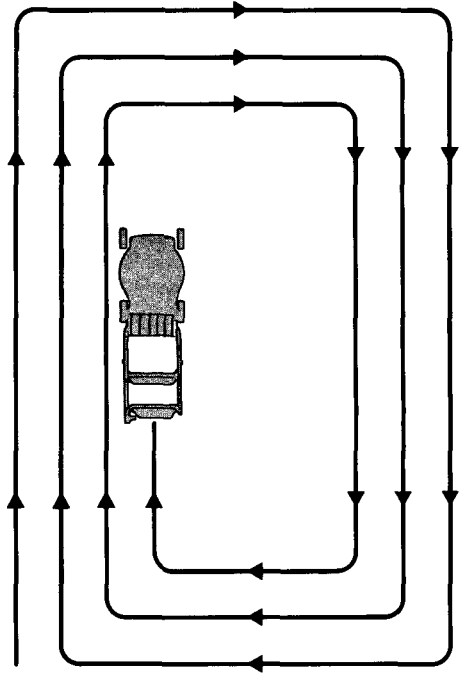

RECOMMENDED MOWING PATTERN

## 7. MOWING RECOMMENDATIONS

---

If the grass is not very thick or tall, you can mow a wide swath, and/or you can move the shift lever (HRA215SXA) to select a fast drive speed. Keep the wheels close to the swath line for maximum cutting width.

If the grass is very thick or tall, cutting a wide swath may slow or stall the engine, clog the cutter deck, and cause poor bagging performance. For thick or tall grass, cut a narrower swath, and/or push the mower more slowly or move the shift lever (HRA215SXA) to select a slower drive speed. If necessary, mow twice; first with a high cut, then at final cutting height.

For best grass cutting and bagging performance, the blade must spin very fast. Always use the FAST throttle setting when mowing, and keep the engine running at or near maximum rpm. If you hear engine speed decrease, that means you should mow a narrower swath, and/or use a slower forward speed. You may also need to raise the mower's cutting height.

Always empty the grass bag or hard-shell grass catcher before it becomes filled to the limit of its capacity. Bagging performance will diminish after the bag or grass catcher becomes about 90% filled. Also, the bag or grass catcher is easier to empty when it is not packed full.

Always empty the grass bag or hard-shell grass catcher when you have finished mowing, even if it is not full. Stored lawn clippings are a fire hazard.

A clogged grass bag will not collect grass efficiently. If the bag becomes clogged with dirt, wash it with a garden hose, and allow it to dry completely before use; a wet bag will clog quickly.

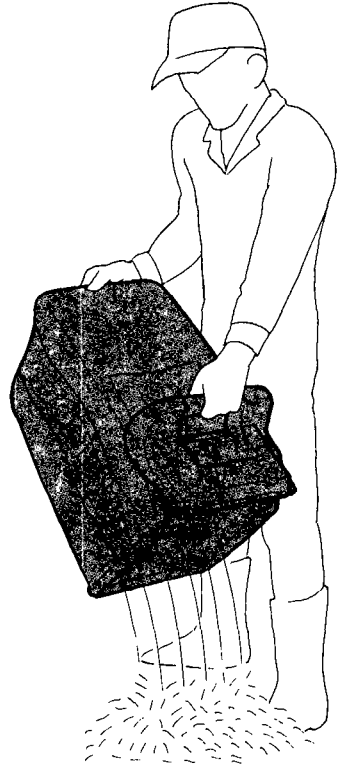

## 8. TRANSPORTING

**⚠ CAUTION** The engine and exhaust system become hot during operation and remain hot for a while after stopping. Contact with hot engine components can cause burns and can ignite some materials.

Avoid touching the engine or exhaust system for at least 15 minutes after the engine has stopped. Allow the engine to cool before transporting the mower.

### Before Loading

- Turn the fuel valve to the OFF position. This will prevent the possibility of carburetor flooding and will reduce the possibility of fuel leakage.

**⚠ WARNING** Gasoline is extremely flammable, and gasoline vapor can explode, causing injury or death. Turn the fuel valve to the OFF position when the mower is not in use.

- Remove the grass bag.

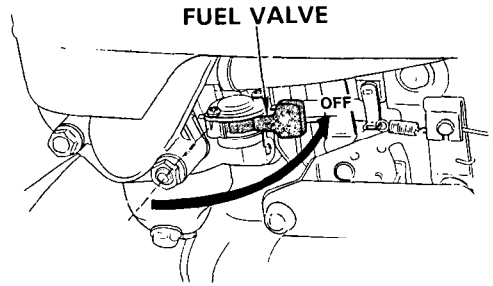

## 8. TRANSPORTING

---

### Loading/Unloading

To reduce the possibility of fuel leakage, keep the mower level while transporting, and avoid tilting the mower excessively when loading and unloading.

- Use a loading ramp with a slope of not more than  $15^\circ$  for pushing the mower on and off the vehicle. If a suitable loading ramp is not available, two people should lift the mower on and off the vehicle, while holding the mower level.

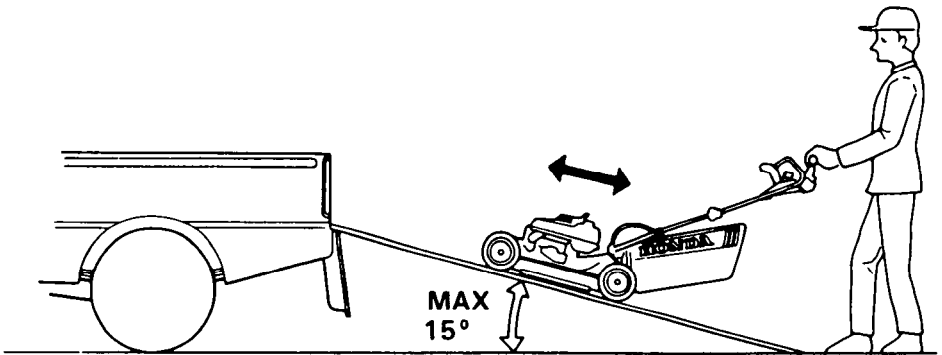

- Position the mower so all 4 wheels are on the bed of the vehicle. Tie the mower down with rope or straps, and block the wheels. Keep the tie-down rope or straps away from controls, adjustment levers, cables, governor arm, carburetor, and the fuel line.

**IMPORTANT NOTICE** HRA215SXA — If the drive clutch is engaged while rolling backward, down the loading ramp, the drive system may become damaged. Avoid moving the drive clutch lever while loading and unloading.

NOTE: The handlebar can be folded by loosening the handlebar locking knobs (see page 52).

# 9. MAINTENANCE

Periodic maintenance and adjustment are necessary to keep the mower in good operating condition. Service and inspect according to the MAINTENANCE SCHEDULE.

To avoid carbon monoxide poisoning, shut the engine off before performing any maintenance.

To avoid serious burns, let the engine cool for at least 15 minutes before performing maintenance.

Use genuine Honda parts or their equivalent for maintenance and repair. Parts of lower quality may damage the mower.

## Maintenance Schedule

REGULAR SERVICE PERIOD		AFTER EACH USE	FIRST 20 HRS (3)	EVERY 50 HRS (3)	EVERY 100 HRS (3)	EVERY 300 HRS (3)
ITEM	Perform at every indicated operating hour interval					
Blade condition and blade bolt tightness	Check	●				
Grass bag and optional attachments	Check	●				
Engine oil	Check level Change	●	●		●	
Air filter	Check Clean	●		● (1)		
Spark plug	Check & clean				●	
Spark Arrester (optional equipment)	Clean				●	
ROTO-STOP	Check		● (2)		● (2)	
ROTO-STOP cable	Adjust		●		●	
Drive clutch cable	Adjust		●		●	
Throttle cable	Adjust		●		●	
Valve clearance	Adjust					● (2)
Fuel tank and filter	Clean					● (2)
Fuel line	Check	Every 2 years (2)				

NOTE: (1) Service more frequently when used in dusty areas.

(2) These items should be serviced by an authorized Honda lawn mower dealer, unless you have the proper tools and are mechanically proficient. Refer to the Honda shop manual.

(3) For professional commercial use, log hours of operation to determine proper maintenance intervals.

## 9. MAINTENANCE

---

### ENGINE OIL CHANGE

Engine oil capacity: 0.63 US qt (0.6 l)

Drain the oil while the engine is warm to assure rapid and complete draining.

1. Place a suitable container under the cutter deck to catch the used oil.
2. Remove the oil filler cap and the oil drain bolt, using a 10 mm box or socket wrench. The used oil will flow along the cutter deck channel to the drain hole under the muffler.

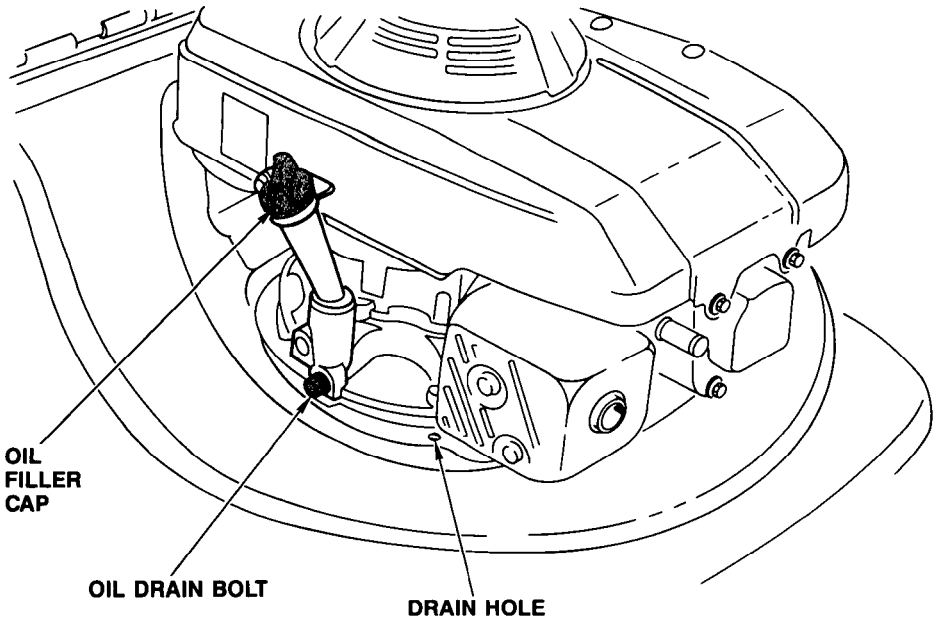

**NOTE:** Please dispose of used motor oil in a manner that doesn't harm the environment. We suggest you take it in a sealed container to your local service station for reclamation. Do not throw it in the trash or pour it on the ground or down a drain.



## 9. MAINTENANCE

3. Install the oil drain bolt and tighten it securely.
4. Fill with the recommended oil (see page 18) to the upper level on the dipstick.
5. Install the filler cap/dipstick.
6. Wipe the cutter deck drain channel clean to reduce dirt build-up when the mower is used.

**NOTE:** Used motor oil may cause skin cancer if repeatedly left in contact with the skin for prolonged periods. Although this is unlikely, unless you handle used oil on a daily basis, it is still advisable to thoroughly wash your hands with soap and water as soon as possible after handling used oil.

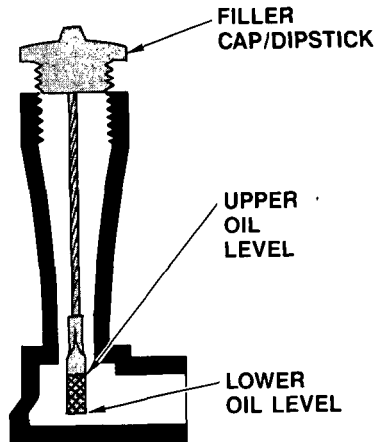
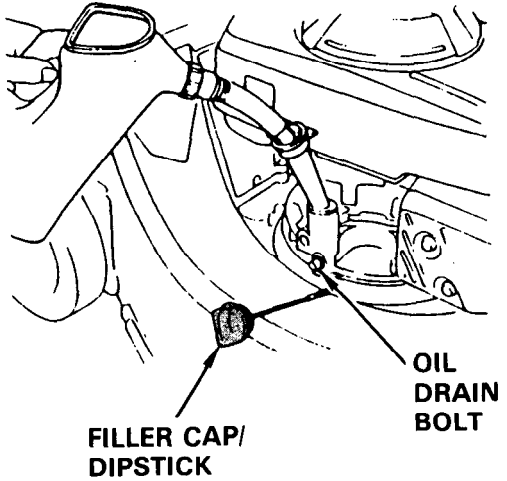

## 9. MAINTENANCE

---

### AIR CLEANER SERVICE

A dirty air filter will restrict air flow to the carburetor, reducing engine performance. If you operate the mower in very dusty areas, clean the air filter more often than specified in the MAINTENANCE SCHEDULE.

**IMPORTANT NOTICE** Operating the engine with no air filter, or a damaged air filter, will cause rapid engine wear.

1. Remove the two cover screws, then remove the air cleaner cover. Remove the air filter, and separate the filter elements. Carefully check both elements for holes or tears, and replace the filter if damaged.
2. Foam element: Clean in warm soapy water, rinse, and allow to dry thoroughly. Or clean in nonflammable solvent and allow to dry. Dip the element in clean engine oil and squeeze out all excess oil. The engine will smoke during initial running if too much oil is left in the foam.

**⚠ WARNING** Using gasoline or flammable solvent to clean the filter element can lead to a fire or explosion. Use only soapy water or nonflammable solvent.

3. Paper element: Tap the element several times on a hard surface to remove excess dirt, or blow compressed air (not exceeding 30 psi) through the filter from the inside. Never try to brush off dirt; brushing will force dirt into the fibers.
4. Wipe dirt from the inside of the air cleaner housing and cover, using a moist rag. Be careful to avoid dropping dirt into the air cleaner duct that leads to the carburetor.
5. Reinstall the air filter and cover.

# 9. MAINTENANCE

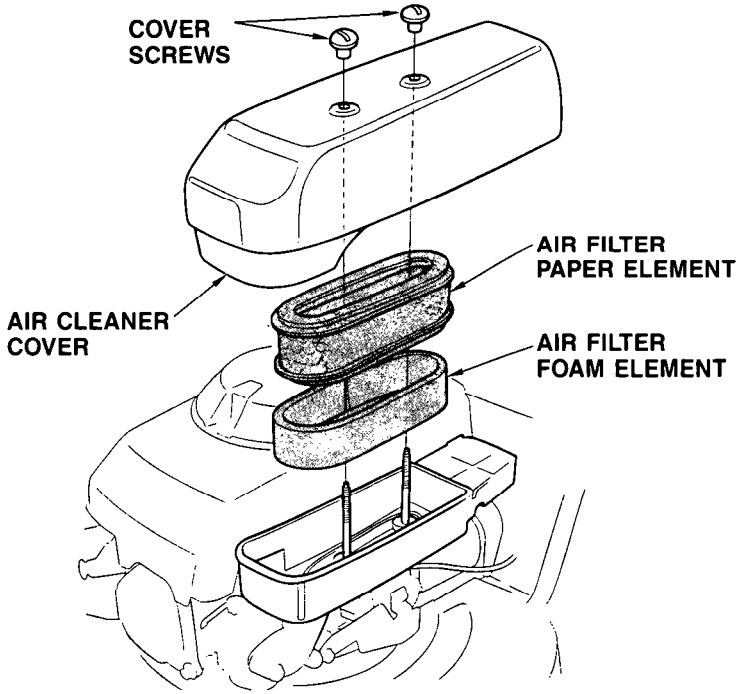

# 9. MAINTENANCE

## SPARK PLUG SERVICE

Recommended spark plugs: NGK BPR5ES  
ND 16EPR-U  
CHAMPION RN12Y

**IMPORTANT NOTICE** Spark plugs of the wrong heat range can cause engine damage.

For good performance, the spark plug must be properly gapped and free of deposits.

1. Disconnect the spark plug cap, and remove any dirt from around the spark plug area.

**CAUTION** Touching the engine or exhaust system while hot can cause burns. Let the engine cool before servicing.

2. Remove the spark plug with a spark plug wrench.
3. Inspect the spark plug. Replace it if the electrodes are worn, or if the insulator is cracked or chipped. Clean the spark plug with a wire brush if you are going to reuse it.
4. Measure the spark plug electrode gap with a feeler gauge. The gap should be 0.024–0.028 in (0.6–0.7 mm). Correct the gap as necessary by carefully bending the side electrode.
5. Install the spark plug carefully, by hand, to avoid cross-threading.
6. After the spark plug is seated, tighten with a spark plug wrench to compress the washer.

**IMPORTANT NOTICE** A loose spark plug can get hot enough to damage the engine. Overtightening may damage the threads.

NOTE: If installing a new spark plug, tighten 1/2 turn after the spark plug seats to compress the washer. If reinstalling a used spark plug, tighten 1/8–1/4 turn after the spark plug seats.

7. Install the spark plug cap on the spark plug.

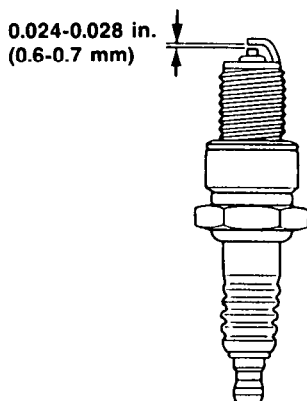
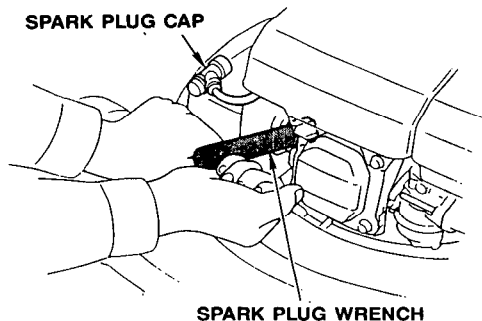

### SPARK ARRESTER MAINTENANCE (optional equipment)

The spark arrester must be serviced every 100 hours to keep it functioning as designed.

**⚠ CAUTION** Touching the engine or exhaust system while hot can cause burns. Let the engine cool before servicing.

1. Remove the two nuts from the muffler shield, using a 10 mm wrench.
2. Remove the muffler shield, identification plate, muffler, and gasket.
3. Remove the spark arrester from the muffler.
4. Check for carbon deposits on the spark arrester and the exhaust port. Brush carbon deposits away. Be careful to avoid damaging the spark arrester screen.
5. Install the spark arrester in the muffler.
6. Install the muffler components on the engine, and tighten the two nuts securely.

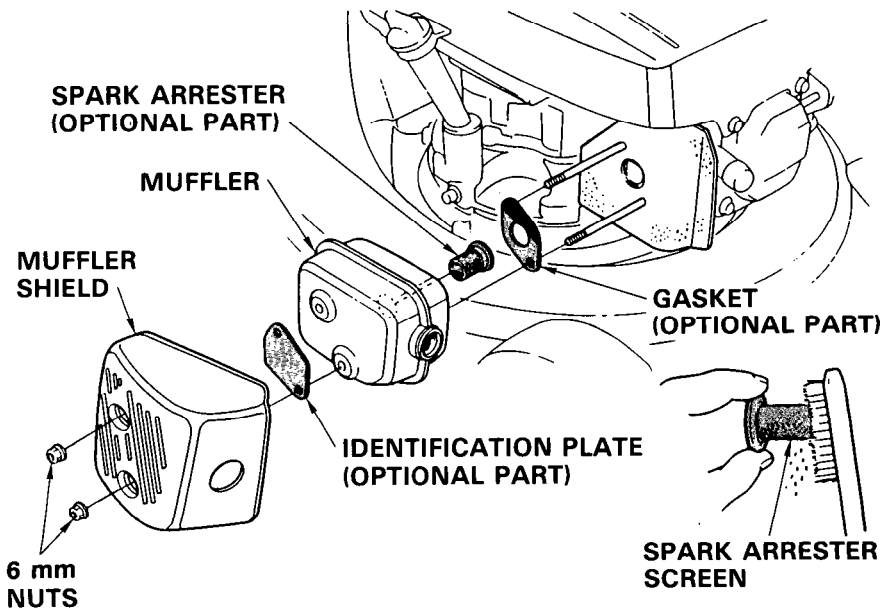

# 9. MAINTENANCE

---

## ROTO-STOP CABLE ADJUSTMENT

1. Measure free play at the tip of the lever, while holding the button down. Free play should be  $9/16$ – $3/4$  in (15–20 mm).
2. If adjustment is necessary, loosen the lock nuts with a 10 mm wrench, and move the adjuster up or down as required. Tighten the lock nuts and recheck free play.

**NOTE:** When mowing, check that the ROTO-STOP lever operates properly. If the blade does not start or stop as it should, and lever free play is correctly adjusted, take the mower to an authorized Honda lawn mower dealer for repair.

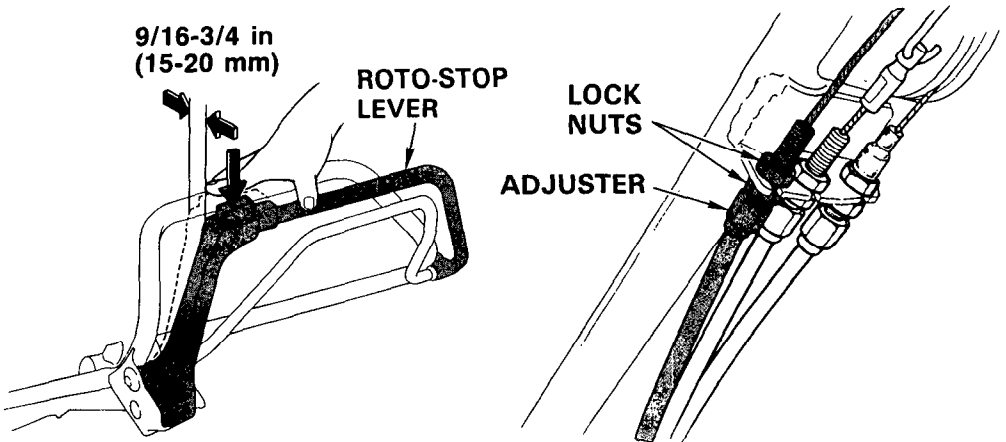

### DRIVE CLUTCH CABLE ADJUSTMENT

1. Measure free play at the top of the lever, as shown. Free play should be  $3/16$ – $3/8$  in (5–10 mm).
2. If adjustment is necessary, loosen the lock nuts with a 10 mm wrench, and move the adjuster up or down as required. Tighten the lock nuts and recheck free play.
3. Start the engine and operate the drive clutch lever. Check to be sure the drive clutch engages and releases properly. If the drive clutch does not operate properly, and lever free play is correctly adjusted, take the mower to an authorized Honda lawn mower dealer for repair.

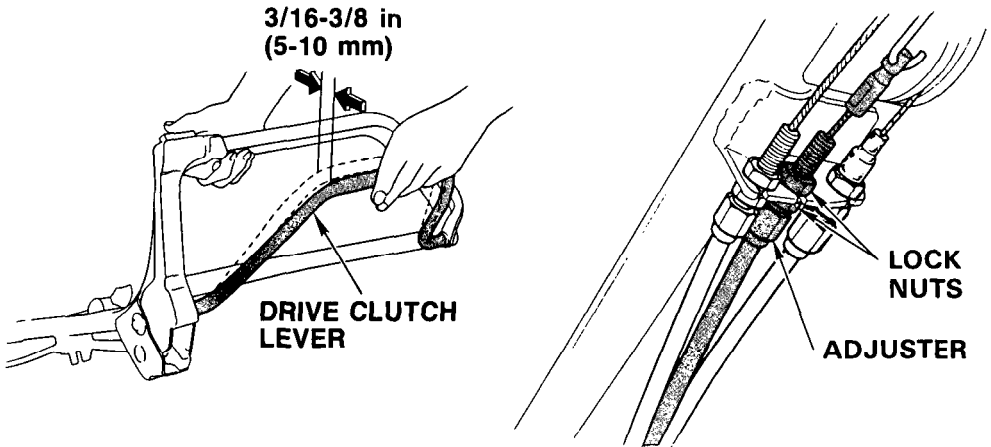

# 9. MAINTENANCE

## THROTTLE CABLE ADJUSTMENT

1. When the throttle lever is moved to the **CHOKE** position, the carburetor choke arm should move all the way counterclockwise, as far as it will go. Push the choke arm with your finger to check that it moves as far as it will go.

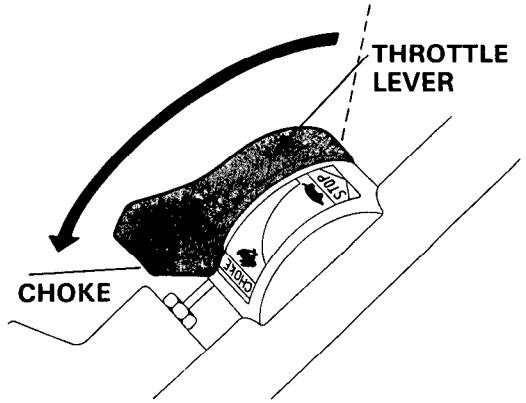

2. If adjustment is necessary, loosen the throttle control cable lock nuts with a 10 mm wrench, and move the adjuster up or down as required. Tighten the lock nuts and recheck carburetor choke arm movement.

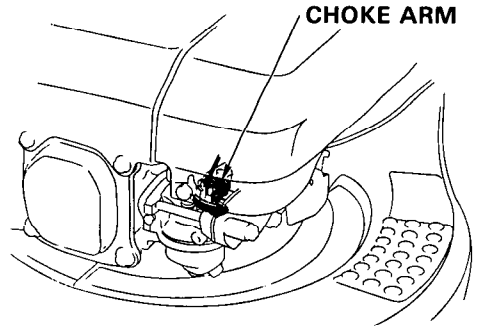

3. Start the engine, and check to be sure the engine stops when the throttle lever is moved to the **STOP** position. Readjust the cable if necessary.

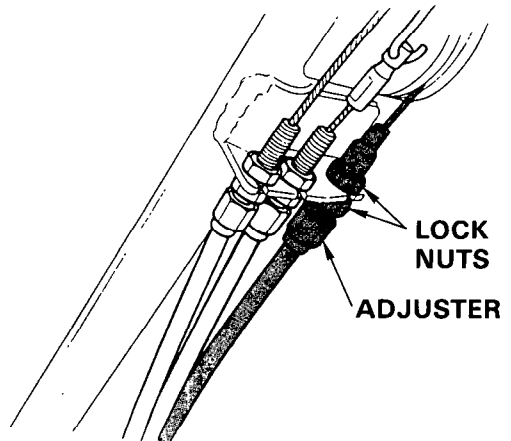



### CARBURETOR ADJUSTMENT

1. Start the engine outdoors, and allow it to warm up to normal operating temperature.

**⚠ WARNING** Exhaust contains poisonous carbon monoxide, a colorless and odorless gas. Breathing exhaust can cause loss of consciousness and may lead to death. To keep exhaust gas from building up, provide adequate ventilation.

2. Set the throttle lever in the SLOW (  ) position.
3. Turn the pilot screw in or out to the setting that produces the highest idle rpm. The correct setting will usually be approximately 2 turns out from the fully closed position.
4. After the pilot screw is correctly adjusted, turn the throttle stop screw to obtain the standard idle speed.

**Standard idle speed: 2,000 ± 150 rpm**

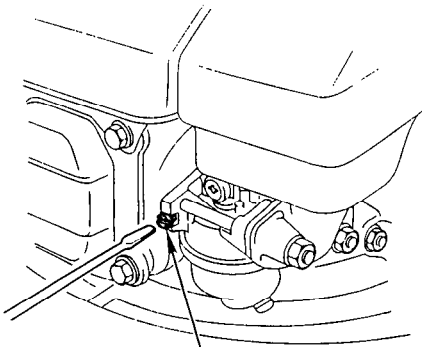

PILOT SCREW

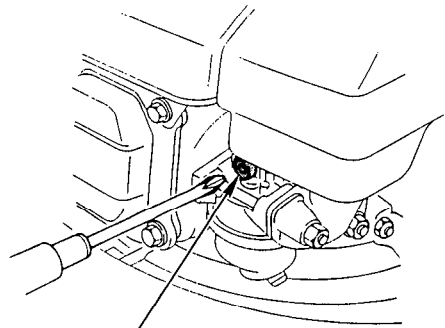

THROTTLE STOP  
SCREW

# 9. MAINTENANCE

## GRASS BAG CLEANING AND REPLACEMENT

When the bag needs cleaning, wash it with a garden hose, and allow it to dry completely before use; a wet grass bag will clog quickly.

Replace a frayed, torn, or deteriorated bag with a Honda replacement bag or its equivalent.

### BAG REMOVAL

1. Pull off one of the cap nuts, using pliers. Or pry off, using two screwdrivers, at opposite sides of the cap nut flange.

#### NOTE:

- To avoid marring the plastic lid while prying off the cap nut, place a thick rag, or other material, under the screwdrivers.
- These cap nuts are not reusable. Discard the cap nut after removal. Obtain a new cap nut for bag installation.

2. Remove the rod and the bag lid.
3. Unclip the plastic edges of the bag, and remove the bag from the frame.

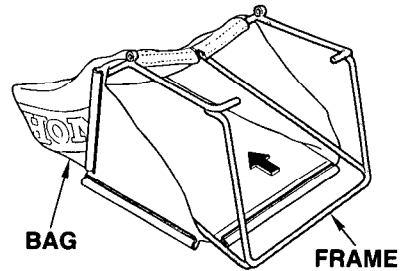
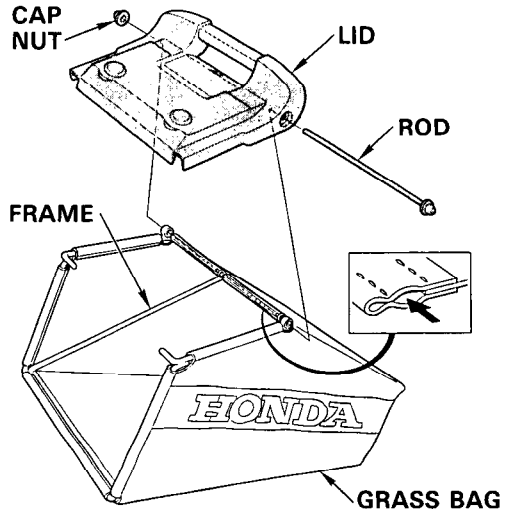

### BAG INSTALLATION

1. Insert the bag frame in the bag as shown.
2. Clip the plastic edges of the bag onto the frame as shown.
3. Insert the rod through the lid, frame, and bag.
4. Secure the rod with a new cap nut. Hit the cap nut with a hammer to drive it onto the rod.

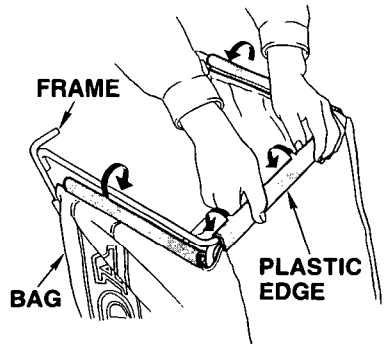

## 9. MAINTENANCE

### BLADE REMOVAL AND INSTALLATION

When the blade needs sharpening or replacement, take the lawn mower to an authorized Honda lawn mower dealer. Or, if you have a torque wrench, you can remove and install the blade yourself. Wear heavy gloves to protect your hands.

- Blade sharpening: To reduce the possibility of weakening the blade, or causing imbalance or poor cutting performance, have the blade sharpened by an authorized Honda lawn mower dealer.
- Blade replacement: Use a genuine Honda replacement blade or its equivalent.

#### Blade Removal

1. Turn the fuel valve OFF, and rest the mower on its right side, so the carburetor side is up.

NOTE: Hard starting and fuel leakage may result if the mower is placed with the carburetor side down.

2. Remove the two blade bolts with a 14 mm socket wrench. Be sure the ROTO-STOP lever is released, so the blade will not move when removing the bolts.
3. Remove the blade and blade holder.

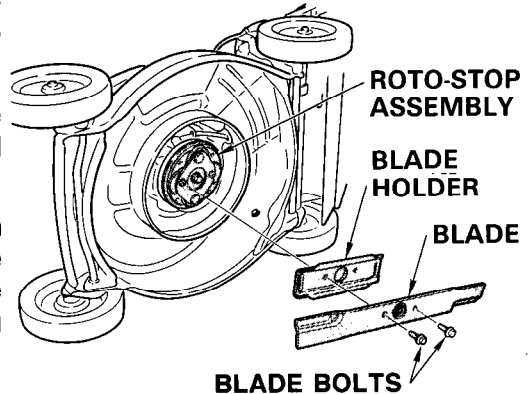

# 9. MAINTENANCE

---

## Blade Installation

1. Clean dirt and grass from the blade mounting area.
2. Position the blade and blade holder on the ROTO-STOP assembly, and install the blade bolts.

### NOTE:

- Be sure the blade is positioned right side up (rear edges turn upward; center hole rim projects downward). If the blade is installed upside down, the edges cannot cut properly, and the center may jam the ROTO-STOP.
  - The blade bolts are specially designed for this application and must not be replaced with any other bolts.
3. Tighten the blade bolts with a torque wrench. Be sure the ROTO-STOP lever is released, so the blade will not move when tightening the bolts. If you do not have a torque wrench, have an authorized Honda lawn mower dealer tighten the blade bolts.

**Blade bolt torque: 36.2–43.4 ft-lb (5.0–6.0 kg-m)**

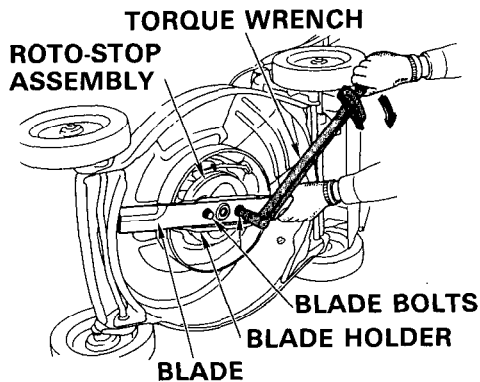

### Preparation for Storage

When the mower will not be used for one month or longer, proper storage preparation will help to prevent rust and corrosion, and will make it easier to start the engine when the mower is removed from storage.

1. Clean all surfaces of the mower, including the area underneath the cutter deck. Wear heavy gloves to protect your hands.

**NOTE:** Before cleaning under the cutter deck, turn the fuel valve OFF, and rest the mower on its right side, so the carburetor side is up. Hard starting and fuel leakage may result if the mower is placed with the carburetor side down.

If you use a garden hose to wash the mower, observe the following precautions:

- If the mower has been running, allow the engine to cool for at least half an hour before spraying water on it. Never spray water on a hot engine.
  - Wash the mower using low water pressure, and keep water away from controls, cable ends, wheel hubs, and all other places that are difficult to dry if water enters.
  - After washing, start the engine outdoors, and let it run until it reaches normal operating temperature to evaporate any water remaining on the engine. Operate the ROTO-STOP lever to expel water from the ROTO-STOP mechanism; allow the blade to spin for 3 or 4 minutes to ensure that no water remains.
  - Stop the engine, turn the fuel valve OFF, and allow the engine to cool before placing the mower in storage.
2. Wash the grass bag, and allow it to dry completely.

**IMPORTANT NOTICE**

**Stored lawn clippings are a fire hazard. Always empty the grass bag after use.**

3. Coat areas that may rust with a light film of oil. Lubricate all control cable cores with a silicone spray lubricant.

# 10. STORAGE

---

4. For prolonged storage, perform these additional steps:

**For storage of 1 or 2 months:**

For storage of 1 or 2 months, be sure the fuel tank is full. If partially filled, air in the tank will promote fuel oxidation and deterioration, resulting in bad fuel that may cause hard starting. Deteriorated fuel may also clog carburetor passages, requiring carburetor repair or replacement.

**NOTE:** The Distributor's Limited Warranty does not cover fuel system damage or engine performance problems resulting from neglected storage preparation.

- a. Fill the fuel tank with fresh gasoline, and add a gasoline conditioner, such as HONDA GAS CONDITIONER, which is formulated to extend fuel storage life.
- b. Run the engine outdoors for 10 minutes to be sure that treated gasoline has replaced the untreated gasoline in the carburetor.
- c. Stop the engine, turn the fuel valve OFF, and allow the engine to cool before placing the mower in storage.

**For storage of more than 2 months:**

- a. Change the engine oil (see page 36).
- b. Remove the spark plug (see page 40). Pour a tablespoon of clean engine oil into the cylinder. Pull the starter rope several times to distribute the oil in the cylinder. Reinstall the spark plug.

**NOTE:** While the spark plug is removed, inspect the plug, and clean, gap, or replace it if necessary.

- c. Pull the starter rope until you feel resistance. This closes the valves, which helps to protect the cylinder from corrosion.

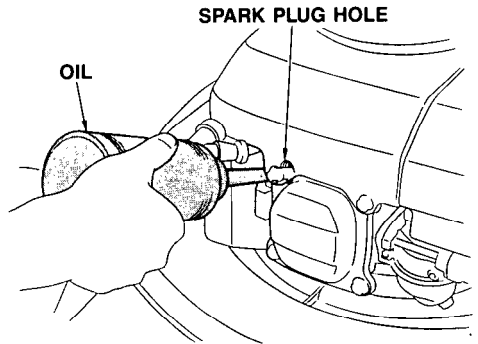

## 10. STORAGE

For storage of more than 2 months (continued):

- d. Disconnect the fuel line from the fuel valve, and drain the fuel tank into an approved gasoline container.

**⚠ WARNING** Gasoline is extremely flammable, and gasoline vapor can explode, causing serious injury or death. Use extreme care when handling gasoline. KEEP OUT OF REACH OF CHILDREN.

- e. Remove the carburetor drain bolt, and drain the carburetor into an approved gasoline container. Tilt the mower to drain all the gasoline from the carburetor.
- f. Install the carburetor drain bolt, and tighten it securely. Connect the fuel line. Turn the fuel valve OFF.

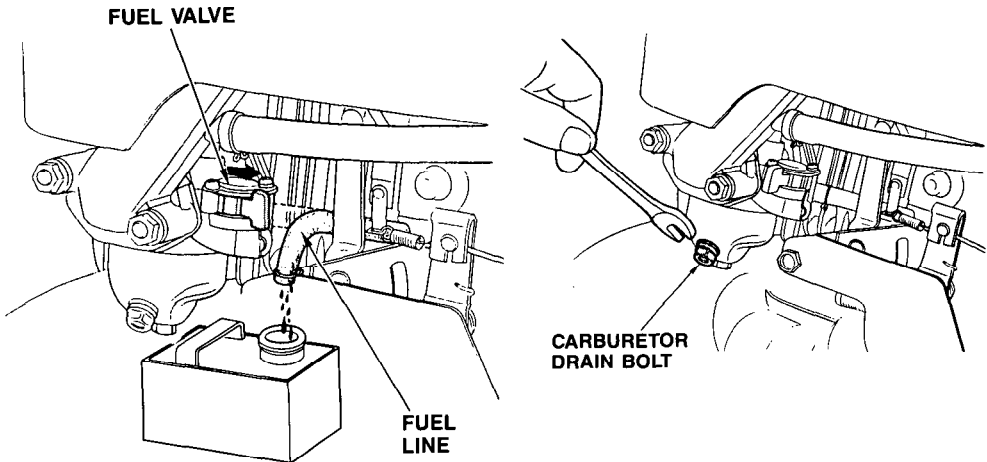

### Storage

Select a storage area away from appliances (water heater or clothes dryer) that use an open flame as a heat source. Power tools, and some battery operated toys, have electric motors that produce sparks that can ignite gasoline vapors.

**⚠ WARNING** Gasoline is extremely flammable, and gasoline vapor can explode.

Avoid storing the mower where it will be exposed to high humidity and dust.

Place the mower with its wheels on a level surface. Tilting the mower may result in fuel leakage.

## 10. STORAGE

---

The handlebar can be folded for compact storage. Loosen the handlebar locking knobs, and fold the handlebar as shown. When folding, be careful to avoid kinking or pinching the control cables.

Cover the mower to keep out dust.

**NOTE:** Plastic sheets should not be used as dust covers; they trap moisture under the covers, promoting rust and corrosion.

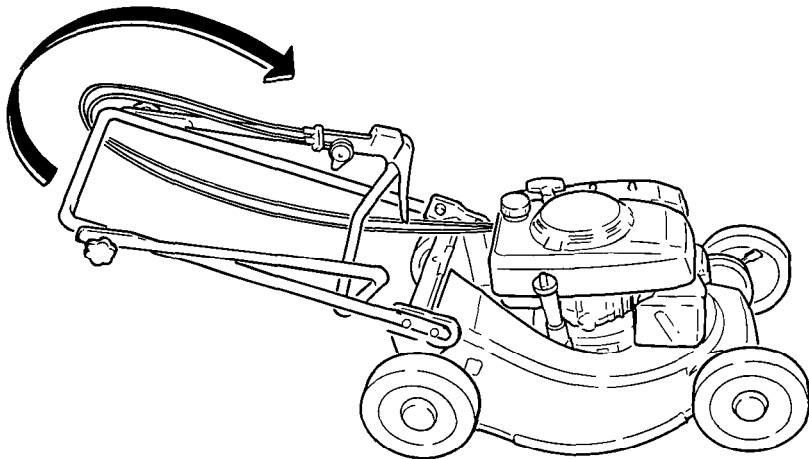

### Removal from Storage

Check all items described in the PRE-OPERATION CHECK section of this manual (pages 16–22).

**NOTE:**

- Fill the fuel tank with fresh gasoline. If you keep a container of gasoline for refueling, be sure that it contains only fresh gasoline. Gasoline oxidizes and deteriorates over time, resulting in bad fuel that may cause hard starting.

**⚠ WARNING** Gasoline is extremely flammable, and gasoline vapor can explode, causing serious injury or death. Use extreme care when handling gasoline. **KEEP OUT OF REACH OF CHILDREN.**

- If the cylinder was coated with oil during storage preparation, the engine will smoke briefly at start up. This is normal.



# 11. TROUBLESHOOTING

## ENGINE

ENGINE WILL NOT START	POSSIBLE CAUSE	CORRECTION
1. Check control positions.	Fuel valve OFF. Throttle lever in wrong position.	Turn fuel valve ON (p. 23). Move throttle lever to CHOKE position, unless the engine is warm (p. 23).
2. Check fuel.	Out of fuel. Bad fuel; mower stored without treating or draining gasoline, or refueled with bad gas.	Refuel (p. 19). Drain fuel tank and carburetor (p. 51). Refuel with fresh gasoline (p. 19).
3. Remove and inspect spark plug.	Spark plug faulty, fouled, or improperly gapped. Spark plug wet with fuel.	Clean, gap, or replace spark plug (p. 40). Dry spark plug and clear flooded engine (p. 25)
4. Take mower to dealer for service or repair.	Fuel filter clogged, carburetor malfunction, ignition malfunction, valves stuck, etc.	Take mower to dealer, or refer to shop manual.

LOSS OF POWER	POSSIBLE CAUSE	CORRECTION
1. Check under cutter deck.	Cutter deck clogged.	Clean out the cutter deck (p. 30).
2. Check air filter.	Air filter clogged.	Clean or replace air filter (p. 38).
3. Check fuel.	Bad fuel; mower stored without treating or draining gasoline, or refueled with bad gas.	Drain fuel tank and carburetor (p. 51). Refuel with fresh gasoline (p. 19).
4. Check vent inside fuel tank cap.	Fuel tank cap vent clogged.	Clean fuel tank cap vent.
5. Take mower to dealer for service or repair.	Fuel filter clogged, carburetor malfunction, valve clearance out of adjustment, low compression, etc.	Take mower to dealer, or refer to shop manual.

# 11. TROUBLESHOOTING

## GRASS CUTTING

<b>POOR CUT QUALITY OR POOR CUTTING PERFORMANCE</b>	<b>POSSIBLE CAUSE</b>	<b>CORRECTION</b>
1. Check that throttle lever is in FAST position.	Engine speed is too slow to cut well.	Move throttle lever to FAST position (p. 9).
2. Reduce forward speed.	Mower is moving too fast for lawn conditions.	Try a slower forward speed. HRA215SXA: Try shift lever positions 1 or 2 (p. 12).
3. Check cutting height adjustment levers.	Adjustment levers set at different positions.	Set both levers in the same cutting height position (p. 13).
4. Check grass bag.	Grass bag is overfilled or clogged.	Empty grass bag, and wash the bag if necessary.
5. Check cutter deck and blade.	Cutter deck is clogged. Blade is dull, worn, or damaged.	Clean out cutter deck. Check blade installation. Sharpen or replace blade if necessary (p. 16 & 47).

## GRASS BAGGING

<b>POOR GRASS BAGGING</b>	<b>POSSIBLE CAUSE</b>	<b>CORRECTION</b>
1. Check grass bag.	Grass bag is overfilled or clogged.	Empty grass bag, and wash the bag if necessary.
2. Check cutter deck and blade.	Cutter deck is clogged. Blade is worn or damaged.	Clean out cutter deck. Check blade installation. Sharpen or replace blade if necessary (p. 16 & 47).

## VIBRATION

<b>EXCESSIVE VIBRATION</b>	<b>POSSIBLE CAUSE</b>	<b>CORRECTION</b>
1. Check blade.	Blade is loose, bent, damaged, or unbalanced by improper sharpening.	Tighten loose blade bolts. Replace blade if necessary (p. 16 & 47).
2. Take mower to dealer for repair.	Mechanical damage, such a bent crankshaft.	Take mower to dealer, or refer to shop manual.

## 12. SPECIFICATIONS

### MOWER MODELS

HRA215SXA Manual starting; self-propelled

### DIMENSIONS

Maximum Length (handlebar extended)	HRA215SXA: 65.4 in (166 cm)
Width at cutter deck	22.2 in (56.5 cm)
Maximum Height (cutting height adjusted to 3 in; 7.6 cm)	42 in (107 cm)
Minimum Height (cutting height adjusted to 1 in; 2.7 cm)	40 in (102 cm)
Dry Weight (including grass bag)	HRA215SXA: 103.6 lb (47 kg)
Grass Bag Capacity	2.36 bushels; 21.9 US gal (83 ℓ)
Cutting Width	20.9 in (53 cm)
Cutting Height (adjustable)	1 in (2.7 cm), 1-1/2 in (4.0 cm), 2 in (5.2 cm), 2-1/2 in (6.4 cm), 3 in (7.6 cm)

### ENGINE

Engine Model	GXV140
Engine Type	4-stroke, overhead-valve, single cylinder, forced air-cooled
Displacement	8.2 cu in (135 cc)
Bore and Stroke	2.52 x 1.65 in (64 x 42 mm)
Ignition System	Transistorized magneto
Ignition Timing	25° BTDC
Idle Speed	2,000 ± 150 rpm
Fuel Tank Capacity	0.26 US gal (1.0 ℓ)
Engine Oil Capacity	0.63 US qt (0.6 ℓ)
Spark Plug	NGK BPR5ES; ND W16EPR-U; Champion RN12Y
Spark Plug Gap	0.024–0.028 in (0.6–0.7 mm)

NOTE: Specifications are subject to change without notice.

# 13. WIRING DIAGRAM

---

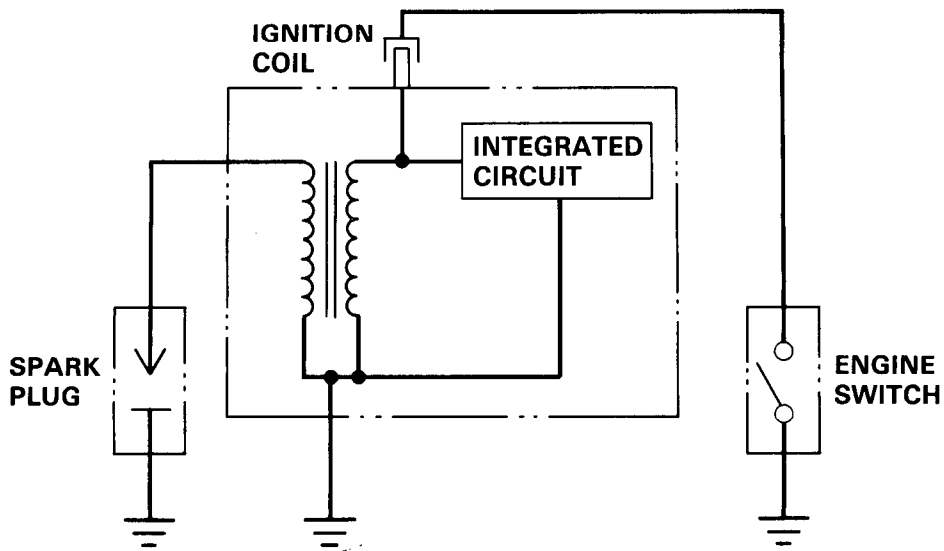

# 14. WARRANTY SERVICE

---

## Owner Satisfaction

Your satisfaction and goodwill are important to your dealer and to us. All Honda warranty details are explained in the Distributor's Limited Warranty. Normally, any problems concerning the product will be handled by your dealer's service department. If you have a warranty problem that has not been handled to your satisfaction, we suggest you take the following action:

- Discuss your problem with a member of the dealership management. Often complaints can be quickly resolved at that level. If the problem has already been reviewed with the Service Manager, contact the owner of the dealership or the General Manager.
- If your problem still has not been resolved to your satisfaction, contact the Power Equipment Division of American Honda Motor Co., Inc.

American Honda Motor Co., Inc.  
Power Equipment Division  
P.O. Box 100021  
Duluth, Georgia 30136-9421  
Telephone: (404) 497-6400

We will need the following information in order to assist you:

- Your name, address, and telephone number
- Product model and serial number
- Date of purchase
- Dealer name and address
- Nature of problem

After reviewing all the facts involved, you will be advised of what action can be taken. Please bear in mind that your problem will likely be resolved at the dealership, using the dealer's facilities, equipment, and personnel, so it is very important that your initial contact be with the dealer.

Your purchase of a Honda product is greatly appreciated by both your dealer and American Honda Motor Co., Inc. We want to assist you in every way possible to assure your complete satisfaction with your purchase.





31VA4A01  
00X31-VA4-A001

JG 6500 9006  
PRINTED IN U.S.A.