

**HONDA**

**Power**

**Equipment**

**Owner's Manual**  
**TRACTOR**  
**H5518H**



**⚠ WARNING: ⚠**

The engine exhaust from this product contains chemicals known to the State of California to cause cancer, birth defects or other reproductive harm.

---

Thank you for purchasing a Honda tractor.

This manual describes operation and maintenance of the Honda H5518 tractor, type A2. (Two Wheel Drive Model) and type A4 (Four Wheel Drive Model).

Information in this manual is based on the H5518 A4 model equipped with a rear hydraulic lift unit which is available as an optional part.

All information in this manual is based on the latest product information available at the time of printing.

Honda Motor Co., Ltd. reserves the right to make changes at any time without notice and without incurring any obligation.

No part of this publication may be reproduced without written permission.

This manual is considered a permanent part of the tractor and it must stay with the tractor if resold.

**READ THIS OWNER'S MANUAL CAREFULLY.** Pay special attention to these symbols and any instructions that follow:

**▲ DANGER**

—Indicates serious injury or death **WILL** result if instructions are not followed.

**▲ WARNING**

—Indicates a strong possibility that serious injury or death could result if instructions are not followed.

**▲ CAUTION**

—Indicates a possibility that minor injury can result if instructions are not followed.

**NOTICE**

—Indicates that equipment or property damage can result if instructions are not followed.

**NOTE:** Gives helpful information.

Honda tractors are designed to give safe and dependable service if operated according to instructions. Operating this tractor requires special effort on your part to ensure your safety and the safety of others.

**▲ WARNING**

Using this product for a purpose not intended may cause injury or property damage. Read and understand this Owner's Manual before operating this tractor.

If a problem should arise, or if you have any questions about your tractor, consult an authorized Honda tractor dealer.

HONDA MOTOR CO., LTD. 1990, ALL RIGHTS RESERVED

# CONTENTS

---

1. SAFETY INFORMATION .....	5
2. SERIAL NUMBERS .....	10
3. COMPONENT IDENTIFICATION .....	11
4. CONTROLS .....	13
INSTRUMENT PANEL .....	13
1. Engine switch .....	13
2. Headlight switch .....	14
3. Fuel gauge .....	14
4. Engine oil warning light .....	15
5. Parking brake warning buzzer .....	15
6. Coolant temperature indicator light .....	16
7. Charge system indicator light .....	16
DRIVE COMPONENTS .....	17
1. Throttle lever .....	17
2. Accelerator pedal (A4 type only) .....	18
3. Choke knob .....	18
4. Brake pedal .....	19
5. Parking brake lock lever .....	19
6. Clutch pedal .....	20
7. Main transmission lever/auxiliary transmission lever .....	20
8. Front P.T.O. clutch lever .....	21
9. Rear P.T.O. lever .....	22
10. Rear P.T.O. shaft/shaft cover .....	22
11. Two- and four-wheel drive select lever (A4 type only) .....	23
12. Differential lock pedal (A4 type only) .....	23
HYDRAULIC LIFT SYSTEM .....	24
1. Hydraulic cylinder selector lever (Rear hydraulic lift type only, option) .....	25
2. Hydraulic lift lever .....	26
3. Descent speed adjust knob .....	27
5. PRE-OPERATION CHECKS .....	28
Engine oil level .....	29
Fuel level .....	30
Fuel recommendation .....	31
Oxygenated fuels .....	32
Air cleaner .....	33
Coolant .....	34

---

Battery electrolyte level .....	35
Hydraulic lift system oil leakage .....	36
Front P. T. O. belt .....	36
Fan belt .....	37
Brake pedal free play .....	37
Brake wear indicator .....	38
Clutch pedal free play .....	38
Tires/wheels .....	39
Hydraulic lift system fluid .....	40
Seat adjustment .....	41
Steering .....	41
Parking brake .....	42
Headlight .....	42
Safety interlock system .....	43
Hydraulic lift system .....	46
6. OPERATION .....	47
1. Starting the engine .....	47
2. Starting/driving .....	49
3. How to use the differential lock (A4 type only) .....	52
4. Two and four-wheel drive (A4 type only) .....	54
5. Turning .....	55
6. Attachment limitations .....	56
7. Driving on a slope .....	63
8. Stopping the engine .....	65
9. Recommended working speed .....	68
10. High altitude operation .....	69

---

7. TRANSPORTING .....	70
8. INSTALLING AN ATTACHMENT .....	72
1. Rear 3-point hitch link installation (option) .....	72
2. Rear 3-point hitch attachment installation .....	74
9. MAINTENANCE .....	76
• The Importance of Maintenance .....	76
• Maintenance Safety .....	77
• Emission Control System .....	78
1. Tool kit .....	81
2. Maintenance schedule .....	82
3. Engine oil change .....	84
4. Air cleaner service .....	85
5. Spark plug service .....	86
6. Battery service .....	88
7. Fuel filter change .....	90
8. Radiator screen/radiator core servicing .....	91
9. Transmission oil inspection .....	92
10. All fastener tightness/lubrication points .....	93
11. Spark arrester maintenance (optional part) .....	95
12. Wheel removal .....	96
13. Fuse replacement .....	97
14. Headlight bulb replacement .....	98
10. LONG TERM STORAGE .....	99
Preparation for storage .....	99
Removal from storage .....	101
11. WIRING DIAGRAM .....	102
12. TROUBLESHOOTING .....	103
13. SPECIFICATIONS .....	108
14. WARRANTY SERVICE INFORMATION .....	110

# 1. SAFETY INFORMATION

Read all safety instructions before operating.

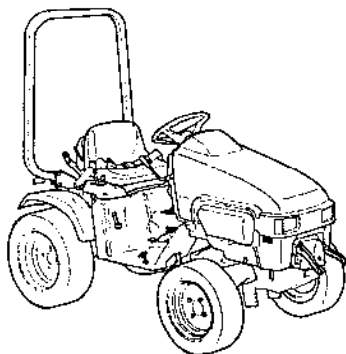

## ⚠ WARNING

- TRACTOR TIP OVER CAN CAUSE SERIOUS INJURY.
  - USE THE SEAT BELT PROPERLY DURING OPERATION.
  - DRIVING TOO FAST, ESPECIALLY WITH IMPLEMENTS, CAN LEAD TO TIP OVER AND SERIOUS INJURY.
  - DO NOT USE 7TH OR 8TH GEAR POSITION WHEN TURNING OR DRIVING ON SLOPES.
- CONTACT WITH ATTACHMENTS OR MOVING PARTS CAN CAUSE SERIOUS INJURY.
  - BE SURE THE ATTACHMENT AND ENGINE ARE STOPPED COMPLETELY BEFORE PLACING HANDS OR FEET NEAR THE ATTACHMENT.
- TRACTORS CAN BE HAZARDOUS IF OPERATED IMPROPERLY.
  - READ OWNER'S MANUAL BEFORE OPERATION.

## ⚠ CAUTION

MUFFLER HOT

## ⚠ WARNING

- AVOID INJURY FROM PTO
- KEEP ALL SHIELDS IN PLACE.
- KEEP HANDS, FEET AND CLOTHING AWAY.
- OPERATE ONLY AT RECOMMENDED PTO SPEED.
- READ OWNER'S MANUAL CAREFULLY.

## OPERATION

### ■ ENGAGE DIFFERENTIAL LOCK

- 1 SHIFT GEARS BELOW 4TH
- 2 TURN STEERING WHEEL STRAIGHT POSITION
- 3 DEPRESS DIFFERENTIAL LOCK PEDAL (LOCK WILL REMAIN ENGAGED AS LONG AS PEDAL IS DEPRECATED)

### ■ DISENGAGE DIFFERENTIAL LOCK

- 1 REMOVE FOOT FROM DIFFERENTIAL LOCK PEDAL (LOCK WILL DISENGAGE AUTOMATICALLY)
- 2 IF DIFFERENTIAL LOCK WILL NOT DISENGAGE, SHIFT TO OPPOSITE DIRECTION AND DRIVE SLIGHTLY

### DIFFERENTIAL LOCK

## ⚠ CAUTION

TO PREVENT TIPPING, LOSS OF CONTROL OR DAMAGE:

- NEVER ENGAGE DIFFERENTIAL LOCK AT HIGH SPEED
- NEVER TURN WITH DIFFERENTIAL LOCKED.
- NEVER OPERATE DIFFERENTIAL LOCK ON PAVED SURFACES.
- NEVER OPERATE DIFFERENTIAL LOCK ON SLOPES OR HILLS.

## ⚠ WARNING

GASOLINE IS FLAMMABLE. STOP ENGINE, AVOID HEAT, SPARKS, AND OPEN FLAME WHEN REFUELING.

## ⚠ WARNING

- DO NOT OPERATE WITHOUT ROLL-OVER PROTECTIVE STRUCTURE (ROPS).
- USE SEAT BELT PROPERLY.

## ⚠ WARNING

- AVOID INJURY FROM PTO
- KEEP ALL SHIELDS IN PLACE.
- KEEP HANDS, FEET AND CLOTHING AWAY.
- OPERATE ONLY AT RECOMMENDED PTO SPEED.
- READ OWNER'S MANUAL CAREFULLY.

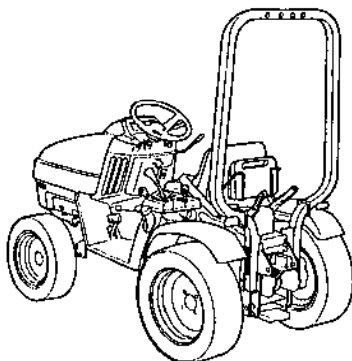

---

## TRACTOR SAFETY

**⚠ WARNING** Operation of the tractor and its attachments requires special efforts on your part to ensure your safety and the safety of others. Know these requirements before you operate the Tractor or its attachments:

### SAFE OPERATING RULES

- Severe personal injury or equipment damage may result if the pre-operation inspection (Pages 28 thru 46) is not performed before operating the tractor or its attachments.
- To avoid severe personal injury or equipment damage, observe the following precautions:
  - All parts, especially guards and shields, should be in good condition, and securely fastened in place.
  - Do not remove any guards, warning labels, shields or safety devices; they are installed for your safety.
  - The rollover protective structure (ROPS) will only help protect you from injury, if:
    - you are also wearing the seat belt.
    - the ROPS is securely attached and has not been modified or structurally damaged.
  - Always wear sturdy shoes and avoid wearing bulky or loose clothing while operating the tractor or its attachments.
  - Never operate the tractor or its attachments when tired or while under the influence of drugs or alcohol.
  - In case of emergency, know how to stop the engine and thoroughly understand the operation of ALL controls.
  - Never permit anyone to operate the tractor or its attachments without proper instructions.
  - Children should not be permitted to operate the tractor or any of its attachments.
  - **KEEP CHILDREN AND PETS AT A SAFE DISTANCE DURING OPERATION**
  - This is an operator only vehicle, do not allow passengers to ride on the tractor or on any of its attachments.
  - The exhaust contains poisonous carbon monoxide gas that can cause loss of consciousness and may lead to death, if the tractor is operated in an enclosed space.



---

## BEFORE STARTING

- The use of heavy equipment and/or pulling excessive loads may adversely affect vehicle stability and control. To avoid loss of control that can result in severe personal injury:
  - Only use recommended hitch attachment points.
  - Limit loads to as suggested on page 56.
  - Be extra careful when turning or backing up.
  - Use counterweight(s) as suggested on page 60.
- Before installing or using any attachment, carefully read all instructions and precautions.

## OPERATION

- Be sure to fasten the seat belt whenever driving the tractor with the Rollover Protective Structure (ROPS) attached. Use of either device (seat belt or ROPS) without the other will increase the chance of injury in a rollover.
- Adjust the seat belt so that it is snug.
- Be sure that the main Transmission lever is in "Neutral" and the front and rear P.T.O. levers are in the "OFF" position before starting the engine.
- Operate the tractor at low speed until you become familiar with all of its operating characteristics and controls.
- Do not operate the tractor or its attachments without ensuring the area in front and behind is clear of people and pets.
- Sudden stops of the tractor while driving at high speed or sudden start-up with the steering wheels turned fully in one direction, could cause the tractor to overturn.
- This tractor utilizes Four Wheel Steering (4WS) for a tighter turning circle and greater mobility than tractors with conventional steering. However, the feel of 4WS is slightly different from other tractors. Practice driving in a wide, safe area.
- Never operate the tractor or its attachments when visibility is diminished by darkness or bad weather; your ability to see obstacles will become impaired.
- Watch out for rocks, roots, holes and other obstacles that may cause the Tractor to overturn.
- This tractor and its attachments are intended for use on relatively flat terrain.
- It is illegal to operate this tractor on public streets, roads, or highways.
- It is legal in some areas to operate a tractor without a U.S.D.A. qualified spark arrester. Check local laws and regulations before operating. An optional spark arrester for this product is available from your authorised Honda tractor dealer.

- 
- When operating the tractor on a slope, always drive up and down the face of the grade. Turning or driving across the face of a slope may cause the tractor to overturn.
  - To avoid loss of control or overturning, always reduce speed and exercise extreme caution when operating on sloping or uneven surfaces.
  - Attempting to change gears while operating the tractor on a slope may adversely affect vehicle stability and control and severe personal injury could result.
  - Do not back down, or rapidly accelerate up, a sloping surface.
  - To avoid loss of control or overturning, do not turn or stop on sloping surfaces.
  - When descending a slope, disengaging the clutch or shifting to neutral can cause a loss of control that may result in severe personal injury.
  - Do not operate the tractor near the edge of a ditch or an embankment. Slipping off the edge could lead to severe personal injury and equipment damage.

To avoid injury to yourself and others, before leaving the Tractor unattended, ALWAYS.

- park on level ground.
- disengage the power take-off.
- lower the attachment(s).
- Lock the parking brake.
- stop the engine.
- and remove the key.
- If you find it necessary to park on a grade, be sure to lock the parking brake and securely block the wheels.
- Be sure to follow the instructions below whenever applying the differential lock.
  - Be sure that the main transmission lever is set in 4th gear or lower, and reduce engine speed before applying the differential lock.
  - Do not apply while turning the tractor.  
Use the lock only when driving straight ahead.
  - Do not rest your foot on the lock pedal while the lock is not in use.
  - Never apply while driving on a paved surface.

---

## **MAINTENANCE SAFETY**

- Before performing maintenance/inspection, read the instructions thoroughly.
- Before cleaning, inspecting or servicing the tractor, be sure to
  - Move the P.T.O. lever to the "OFF" position and lower any attachments.
  - Stop the engine and remove the key.
  - Remove the spark plug caps.
- If you hit an object, stop the engine and inspect the Tractor and its attachments.  
Fix any damage before you resume operation.
- Operating the tractor with damaged, worn or broken parts may result in severe personal injury.
- Leaves, grass clippings, oil and other combustible materials can become a fire hazard. Be sure the body, engine and drive mechanism areas are kept clean.
- All nuts, bolts and fasteners must be tight.
- Do not change the engine governor settings or the engine may be damaged.

## **STORAGE SAFETY**

- To avoid the possibility of fire, allow the engine and exhaust system to cool before storing the tractor in an enclosed space or near combustible materials.
- When storing the tractor, be sure to apply the parking brake and remove the engine key.
- Drain all gasoline from the carburetor and fuel tank, and disconnect the battery ground cable.

## 2. SERIAL NUMBERS

---

Record the frame and engine serial numbers for your reference. Refer to the serial numbers when ordering parts, and when making technical or warranty inquiries (see page 110).

The frame serial number is stamped on the right side of the frame. The engine serial number is stamped under the air cleaner (inside the engine compartment).

Frame serial number: \_\_\_\_\_

Engine serial number: \_\_\_\_\_

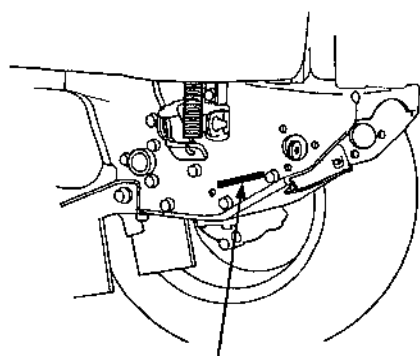

FRAME NUMBER

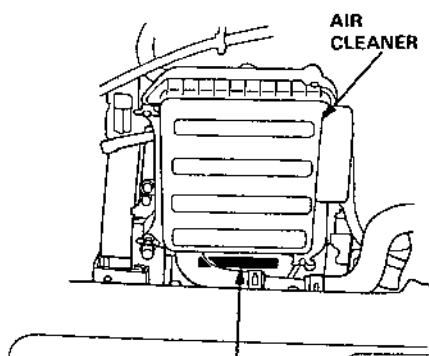

ENGINE NUMBER

### 3. COMPONENT IDENTIFICATION

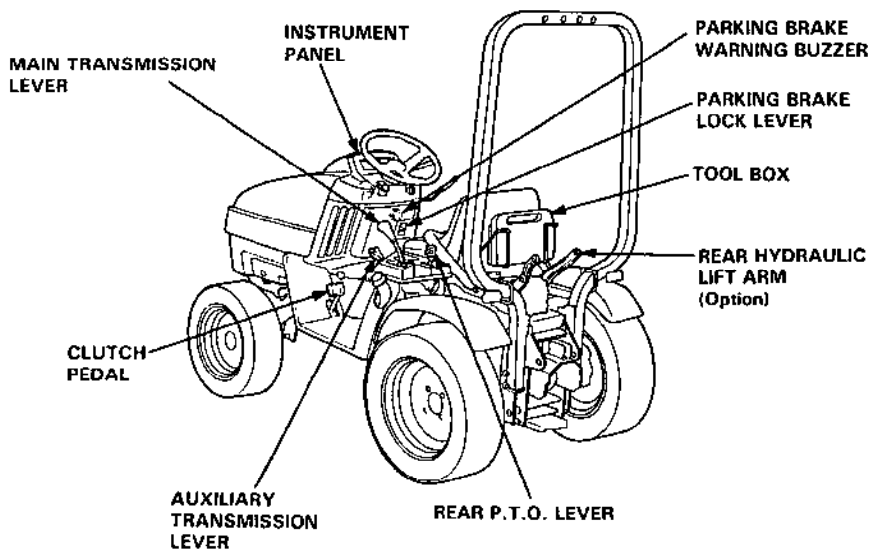
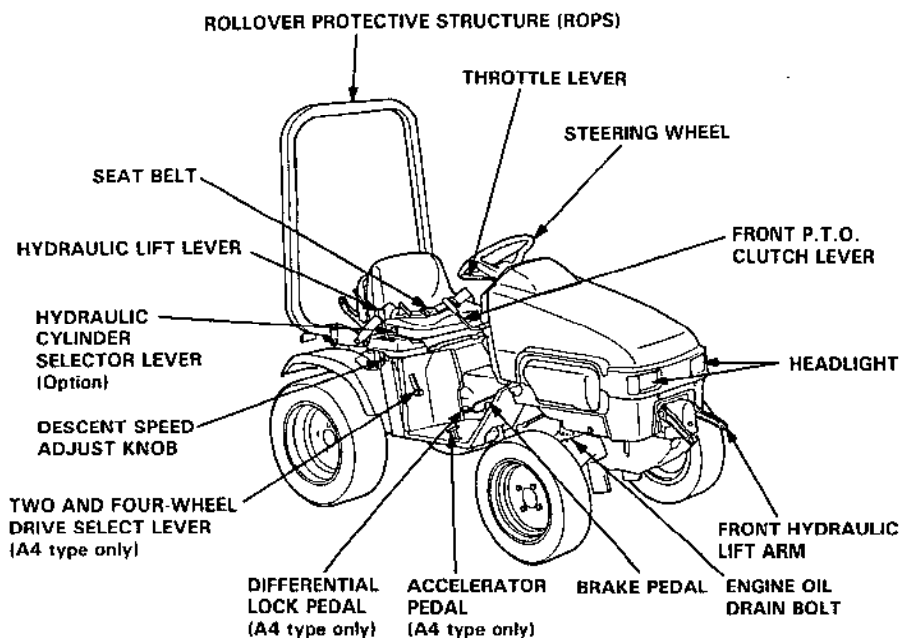

---

ENGINE HOOD

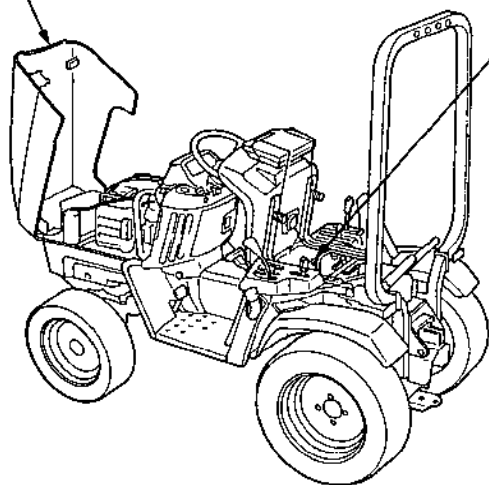

HYDRAULIC SYSTEM  
FLUID FILLER CAP

AIR CLEANER

ENGINE OIL  
DIPSTICK

RADIATOR  
RESERVE TANK

ENGINE OIL  
FILLER CAP

FRONT P.T.O.  
BELTS

FAN BELT

BATTERY

SPARK PLUG CAPS

FUSE BOX

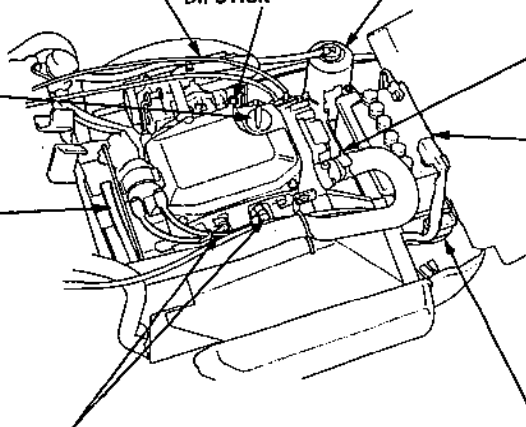

## 4. CONTROLS

### INSTRUMENT PANEL

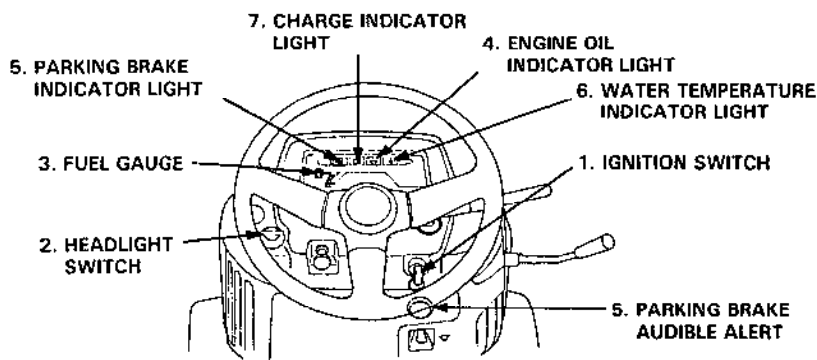

#### 1. Engine switch

**WARNING** Always remove the key from the engine switch whenever the tractor is unattended to prevent children or unauthorized persons from starting the engine.

This tractor is equipped with an automotive type ignition switch, which controls all the electrical circuits.

Key positions: "START" to start the engine.

"ON" to run the engine after starting.

"OFF" to stop the engine (IGNITION OFF).

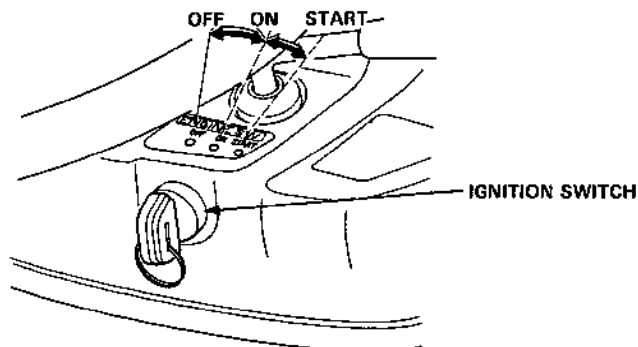

**NOTICE** Do not leave the ignition switch "ON" (key on "ON" position) when the engine is not running as the battery will discharge.

**NOTE:** The starter motor will not work unless the main transmission lever is in "N (Neutral)" the front and rear P.T.O. levers are in the "OFF" position.

## 2. Headlight switch

The headlight switch turns the headlights ON and OFF.

**NOTICE** Poor visibility increases the risk of striking hidden objects. Reduce speed when operating the tractor in low light conditions.

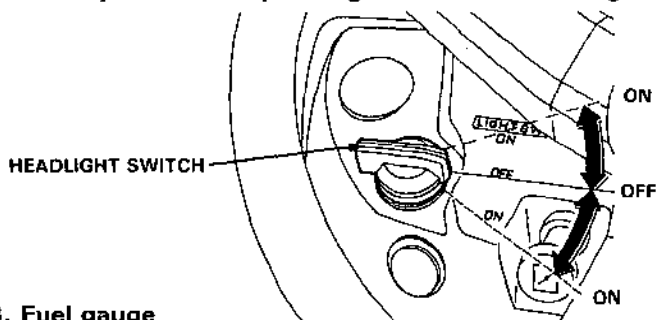

## 3. Fuel gauge

The fuel gauge indicates the amount of fuel in the tank. It operates when the ignition switch is in the ON position.

**NOTE:** When the ignition switch is in the OFF position, the fuel gauge will indicate a faults fuel level.

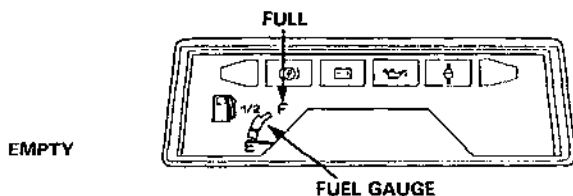

When the fuel gauge needle enters under the red zone, it indicates that the amount of remaining fuel in the tank is about 2.0 liters (0.5 gal). Refill as soon as possible.

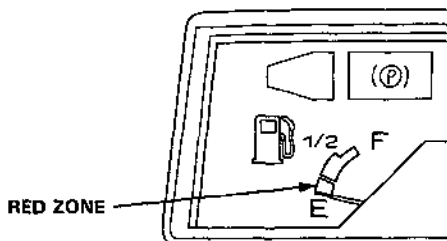



#### 4. Engine oil indicator light

If the oil level falls below normal operating level while the engine is running, the indicator light will come on.

If the warning light comes on while the engine is running, stop the engine immediately, check the engine oil level and add enough of the recommended oil to bring the level to the upper mark on the dipstick (See page 29). If the oil warning light should come on, and the oil level is registering correctly on the oil dipstick, contact your authorized Honda tractor dealer before using the tractor.

**NOTICE** Running the engine with insufficient oil level can cause serious engine damage.

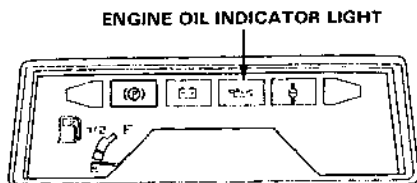

#### 5. Parking brake indicator light/audible alert

There is a parking brake indicator light/audible alert to remind you to release the parking brake lock before driving the tractor.

The warning light/audible alert will sound and come on continuously if the transmission is shifted into gear while the parking brake is locked.

**WARNING** Operating the tractor with the parking brake locked will result in severe damage to the brake lining, and could lead to a complete brake system failure.

**NOTICE** When washing the tractor, do not spray water directly into the warning buzzer.

PARKING BRAKE INDICATOR LIGHT

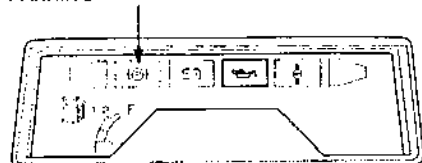

PARKING BRAKE AUDIBLE ALERT

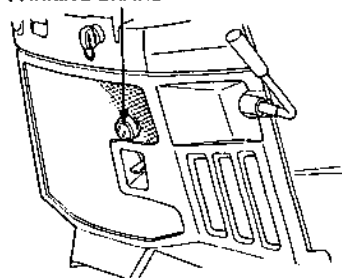

## 6. Coolant temperature overheating light/buzzer

The light comes on when the coolant temperature is above the operating range. If indicator light comes on during operation:

- Stop the engine immediately.
- Open the engine hood and check coolant level.
- Check the radiator screen for clogging. Remove debris from the screen as necessary (see page 91).
- Check fan belt.

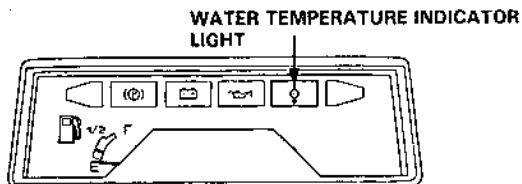

## 7. Charge Indicator light

If this light come on when the engine is running, it indicates that the battery charging system is malfunctioning. Stop the engine and have your tractor's charging system checked by your authorized Honda tractor dealer.

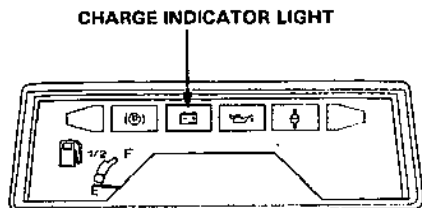

## DRIVE COMPONENTS

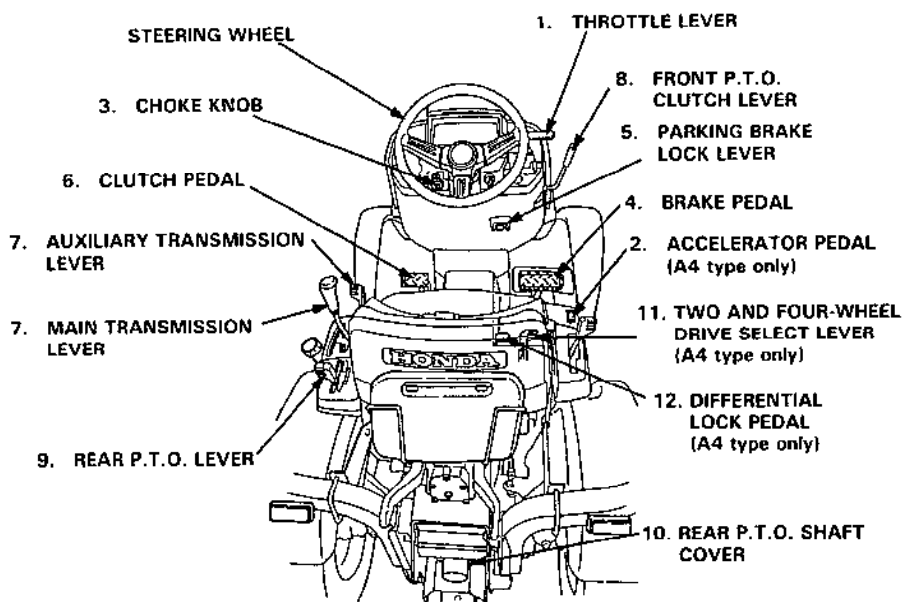

### 1. Throttle lever

The throttle lever controls engine speed from SLOW (idle) to FAST (max speed); it will stay in any designated position.

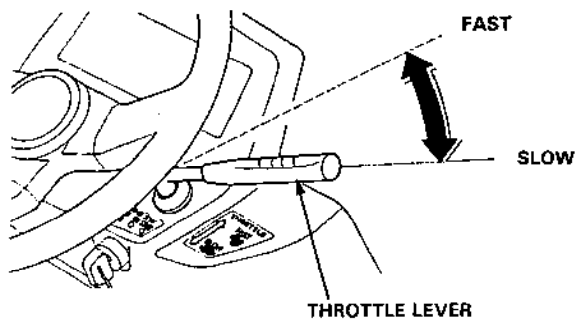

## 2. Accelerator pedal (A4 type only)

The accelerator pedal should be used with the throttle lever set in SLOW (idle) position. Depress the pedal to increase the engine speed. Releasing the foot from the pedal causes the engine speed to decrease. Use this pedal when propelling on roads or transporting your tractor from one place to another.

**CAUTION** The minimum speed of the engine is determined by the position of the throttle lever. When the throttle lever is set in FAST position, the engine speed is not lowered to the idle speed when the pedal is released and can cause accident or injury.

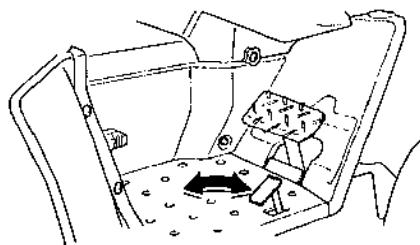

ACCELERATOR PEDAL

## 3. Choke knob

Operate the choke knob to start the engine when the engine is cold.

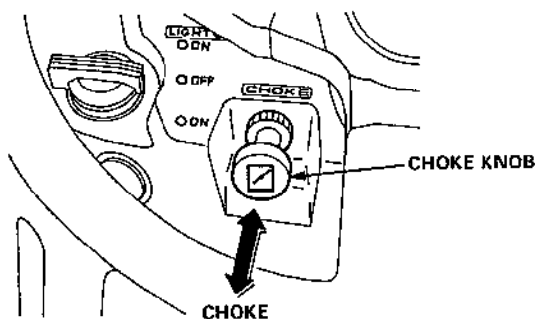

#### 4. Brake pedal

The brake pedal is used to slow the tractor.

When you want to bring the tractor to a full stop, be sure to depress the clutch pedal first, then the brake pedal.

#### NOTICE

- Depressing the brake pedal hard while the tractor is being driven may cause damage to the tractor drive components unless the clutch pedal is depressed first.
- Driving the tractor with the brake pedal partly depressed can damage the brake lining.

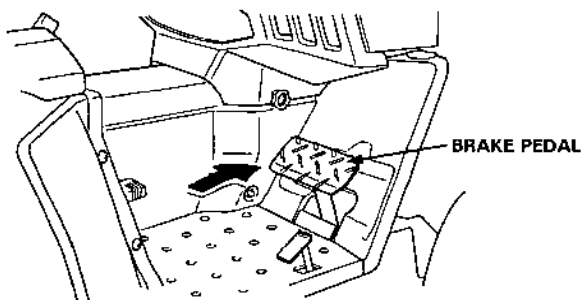

#### 5. Parking brake lock lever

The parking brake lock lever is used when the tractor is stopped.

1. Firmly depress and hold the brake pedal.
2. Push and hold the parking brake lock lever.
3. Release the brake pedal and then release the parking brake lock lever.
4. To release the parking brake, push the brake pedal once.

#### NOTICE

Operating the tractor with the parking brake locked will result in severe damage to the brake lining, and could lead to a complete brake system failure.

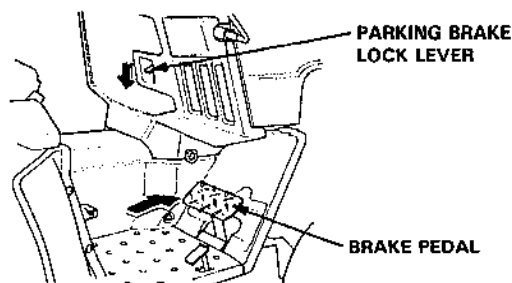

## 6. Clutch pedal

Depress the clutch pedal and come to a complete stop before operating the main transmission lever, auxiliary transmission lever, Two and Four-Wheel drive select lever or the rear P.T.O. lever.

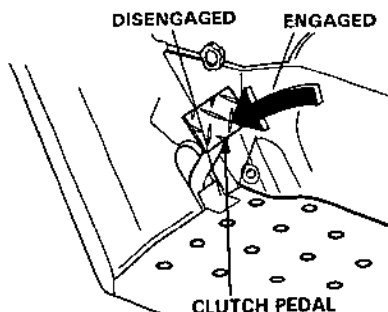

## 7. Main transmission lever/auxiliary transmission lever

Eight forward and four reverse speeds can be selected by shifting the main and auxiliary transmission levers. For each slotted position of the main transmission lever, one of two speeds can be selected by either moving the auxiliary lever up (higher position) or down (lower position).

[HIGH GEAR POSITION]

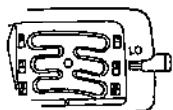

[LOW GEAR POSITION]

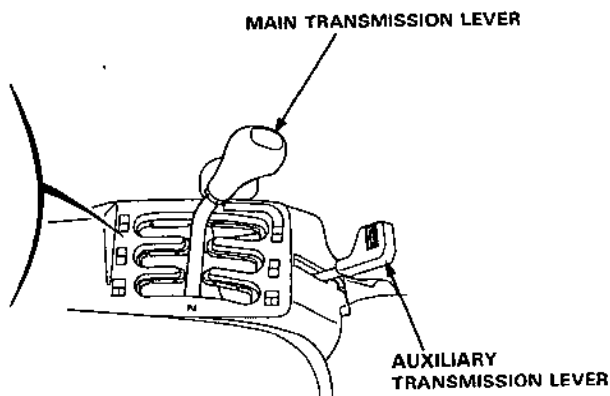
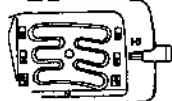

### NOTICE

- Transmission damage can occur if the clutch pedal is not depressed first, before moving the shift levers.
- Do not operate the transmission levers while the tractor is moving. This can cause internal transmission damage.

---

## 8. Front P.T.O. clutch lever

The lever is used to engage or disengage the front P.T.O. (Power Take Off) shaft.

Lever in "ON" position—P.T.O. shaft rotates

Lever in "OFF" position—P.T.O. shaft stops

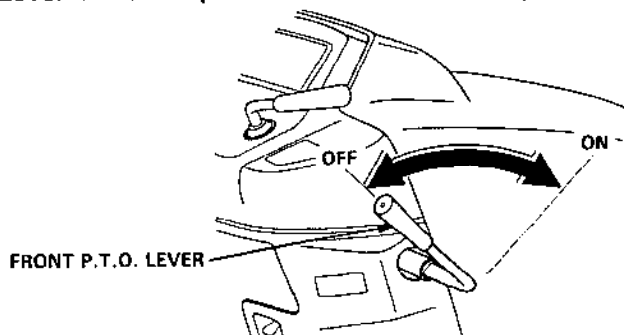

When engaging the front P.T.O., always use a quick, smooth motion to prevent premature wear.

**NOTE:** An interlock switch prevents the engine from starting unless the P.T.O. clutch lever is in the OFF position.

## 9. Rear P.T.O. lever

The lever is used to engage or disengage the rear P.T.O. shaft. The rear P.T.O. shaft rotates when the rear P.T.O. lever is set in the "ON" position and the clutch pedal is released.

Lever in "ON" position and clutch pedal is released—P.T.O. shaft rotates.  
Lever in "ON" position and clutch pedal is depressed—P.T.O. shaft disengaged.

Lever in "OFF" position—P.T.O. shaft disengaged.

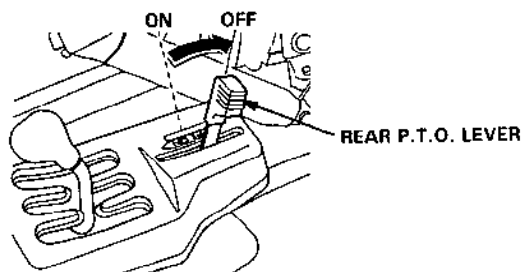

**NOTICE** Before operating the P.T.O. lever, completely stop the tractor and depress the clutch pedal to avoid internal transmission damage.

**NOTE:** An interlock switch prevents the engine from starting unless the rear P.T.O. lever is in the "OFF" position.

## 10. Rear P.T.O. shaft/shaft cover

The rear P.T.O. shaft is a coupling device which is used to transmit power from the engine to an attachment installed at the rear of the tractor. Install the cover over the shaft whenever the rear P.T.O. shaft is not used.

**WARNING** Operating the tractor without installing the cover over the shaft is very hazardous because clothing or other articles may be caught on the rotating shaft.

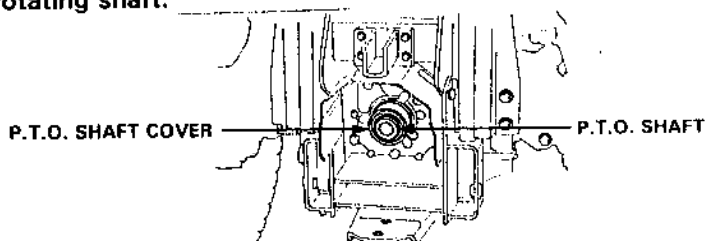



## 11. Two- and four wheel drive select lever (A4 type only)

Two and four wheel drive can be selected by operating this lever. To shift into four wheel drive, move the shift lever up to the four wheel drive position. For two wheel drive, move the shift lever down to the two Wheel Drive position.

**NOTICE** Before shifting the lever, be sure to bring the tractor to a complete stop and depress the clutch pedal fully.

For operation of the two-and four-wheel drive select lever, refer to page 54.

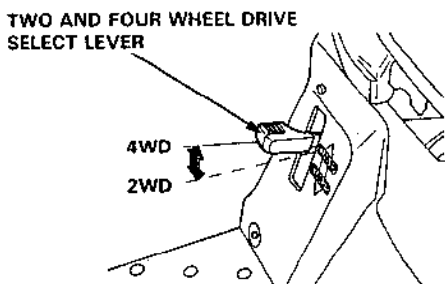

## 12. Differential lock pedal (A4 type only)

When greater straight-line traction is desired on loose or soft terrain, pushing and holding the pedal locks the differential, causing both rear wheels to rotate at the same speed. For normal operation, the pedal should be released (unlocked) so that the differential allows one rear wheel to rotate at a different speed than the other around curves.

To release the lock remove your foot from the pedal.  
For operation of the differential lock, refer to Page 52.

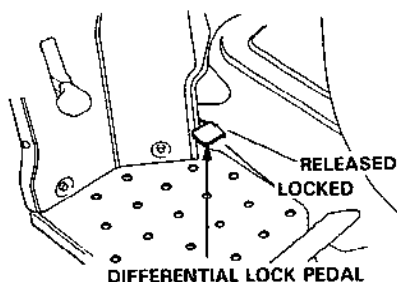

---

## HYDRAULIC LIFT SYSTEM

The front attachment can be raised and lowered by operating the hydraulic lift lever, when the engine is running.

NOTE: On models equipped with a rear hydraulic lift unit, the front and rear attachments can be lifted and lowered by operating the hydraulic cylinder selector lever and hydraulic lift lever, when the engine is running.

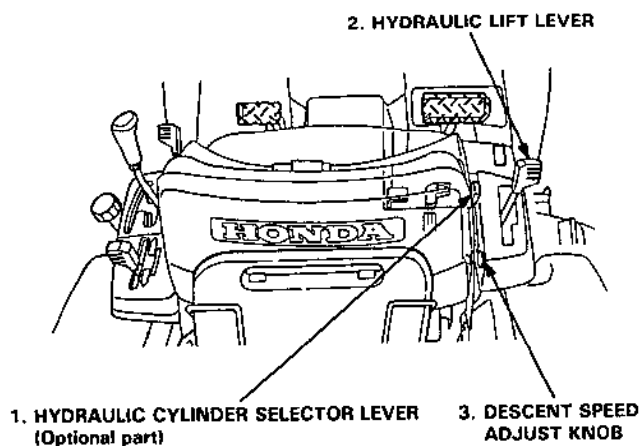

## 1. Hydraulic cylinder selector lever (Rear hydraulic lift type only, option)

The oil pressure from the oil pump can be changed to either the front or rear hydraulic system by operating this lever.

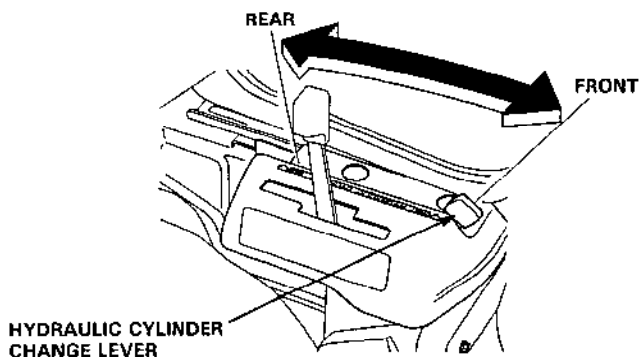

**NOTICE** Always move the lever fully into the Front or Rear position. Leaving the lever halfway between these two positions may damage the hydraulic system or interfere with its normal operation.

Observe the following when operating the hydraulic cylinder selector lever:

- 1. To prevent lowering of attachment, turn the descent speed adjust knob clockwise fully to SLOW.
- 2. Place the lift lever in the DOWN position.
- 3. Place the selector lever in the FRONT or REAR position.
- 4. Turn the descent speed adjust knob out as necessary to obtain the desired speed.

## 2. Hydraulic lift lever

The attachment can be raised and lowered by operating this lever. In the SLOW UP position, the attachment will lift slowly and in the FAST UP position, the attachment will lift quickly. In the SLOW DOWN position the attachment will lower slowly and in the FAST DOWN position the attachment will lower more quickly. In either DOWN setting, the attachment will be lowered even though the engine is stopped. The attachment will be stopped at its current position when the lever is set in NEUTRAL.

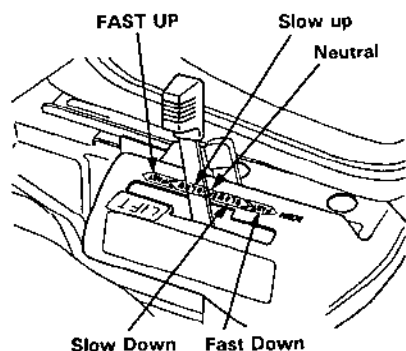
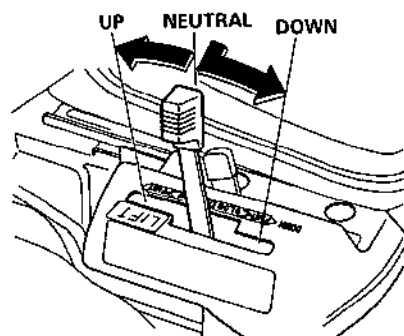

**NOTICE** Do not hold the lift lever in the FAST UP or SLOW UP position after the attachment is fully raised. Holding the lever in these positions can cause damage to the hydraulic system.

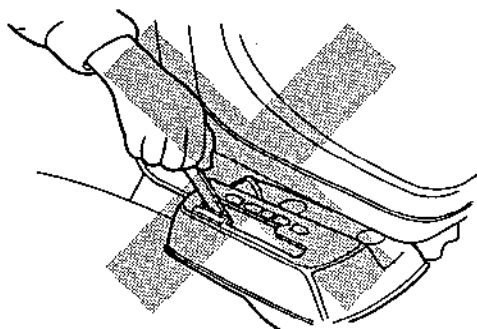

### 3. Descent speed adjust knob

Descending speed can be pre-adjusted to compensate for the weight of the attachment. Adjust the knob so that an attachment will be lowered to the ground from its highest position within 1-2 seconds with the lift lever in the FAST DOWN position.

Thus, lighter attachments may require more FAST pre-adjustment and heavier attachments may require more SLOW pre-adjustment. However, too much or too little pre-adjustment will limit the operating speed range selectable by the lift lever.

Before adjusting the descending speed, it is necessary to set the lift lever in NEUTRAL.

Turning the knob clockwise toward SLOW will decrease the speed, and turning it counterclockwise toward FAST will increase the speed. The attachment will not descend when this knob is turned fully to SLOW.

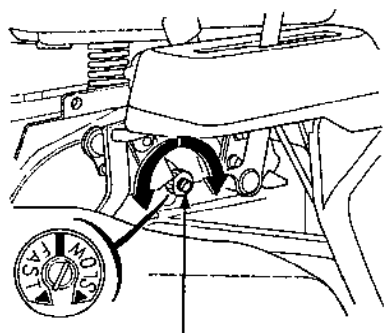

DESCENT SPEED ADJUST KNOB

#### **CAUTION**

- Before performing any inspection or adjustment pay particular attention to your safety as well as the safety of others.
- Always park the tractor on level ground with the parking brake set.
- Lower the attachment and set the lift lever in NEUTRAL before adjusting descent speed.

#### **NOTICE**

Do not overtighten the descent speed adjust knob.

When adjusting the descent speed, always make adjustment in increments of 1/4 turn or less. Adjustment range from SLOW-FAST approximately 4 full turns.

## 5. PRE-OPERATION CHECKS

---

For safe and efficient operation, always perform the pre-operation checks before using the tractor.

Follow the procedures below and check all of the following items before each use:

1. Park the tractor on a level surface.
2. Lock the parking brake, set the transmission lever in "N" (Neutral) and the front and rear P.T.O. levers in the "OFF" positions.
3. Disconnect the spark plug cap and remove the key to prevent accidental engine start-up.

**WARNING** If the engine is started accidentally while you are performing the pre-operation checks, moving parts may cause serious injury.

### OPENING/CLOSING THE HOOD

To open, pull up at the grip area until the hood stops at the fully open position.

**NOTICE** Opening hood without hand control can damage hood if front hydraulic lift arms are in the up position.

To close, slowly lower the hood until it seats in the spring clips.

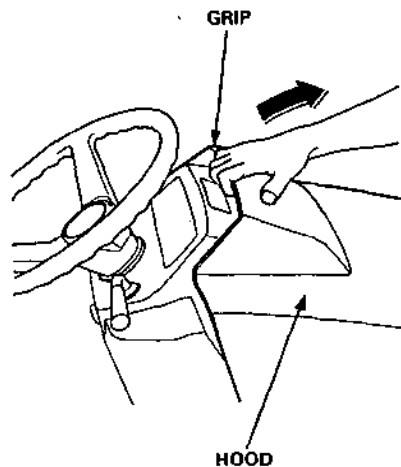

## Engine oil level

**NOTICE** Running the engine with low oil level will cause serious engine damage.

1. Place the tractor on a level surface.
2. Open the hood and clean the engine block around the dipstick. Remove the dipstick and wipe it clean.
3. Reinsert the dipstick.
4. Check the oil level shown on the dipstick. If near or below the lower level mark, fill to the upper level mark with the recommended oil.
5. Install the oil level dipstick securely.

Use 4-stroke motor oil that meets or exceeds the requirements for API service classification SF or SG. Always check the API SERVICE label on the oil container to be sure it includes the letters SF or SG.

**NOTICE** Using nondetergent oil or 2-stroke engine oil could shorten the engine's service life.

SAE 10 W-30 is recommended for general, all-temperature use. Other viscosities shown in the following chart may be used when the average temperature in your area is within the indicated range.

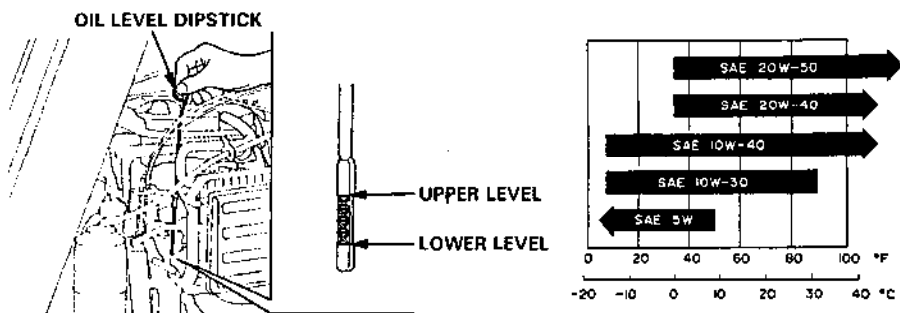

## Fuel level

Turn the engine switch (ignition switch) ON and check the fuel gauge. If the fuel level is low, pour gasoline through the filler opening slowly up to the UPPER level line on the filler neck.

Fuel tank capacity: 9.3 ℓ (2.5 US gal).

### **▲ WARNING**

Gasoline is extremely flammable, and gasoline vapor can explode. Use extreme care when handling gasoline. Keep gasoline out of reach of children.

- Refuel in a well ventilated area with the engine stopped. Keep flames and sparks away, and do not smoke in the area.
- Gasoline vapors or spilled gasoline may ignite.
- Refuel carefully to avoid spilling gasoline. Avoid overfilling the fuel tank (there should be no gas in the filler neck). After refueling, tighten the gas cap securely. If any gasoline was spilled, make sure the area is dry before starting the engine.
- After use, park the utility tractor on a level surface. Be sure the storage area is well ventilated, do not allow flames or sparks in the storage area.

After refueling, be sure to tighten the fuel tank cap firmly.

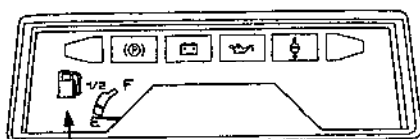

FUEL GAUGE

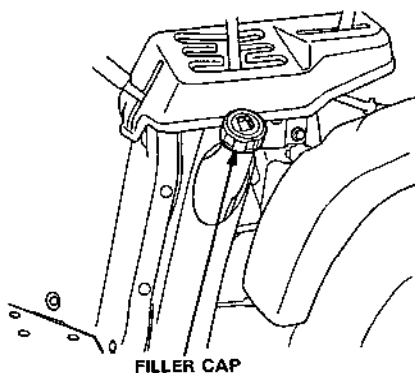
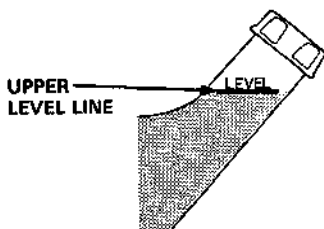



---

## Fuel recommendation

Use unleaded gasoline with a pump octane rating of 86 or higher. This engine is certified to operate on unleaded gasoline.

Unleaded gasoline produces fewer engine and spark plugs deposits and extends exhaust system life.

Never use stale or contaminated gasoline or oil/gasoline mixture. Avoid getting dirt or water in the fuel tank.

Occasionally you may hear light "spark knock" or "pinging" (metallic rapping noise) while operating under heavy loads. This is no cause for concern.

If spark knock or pinging occurs at a steady engine speed, under normal load, change brands of gasoline. If spark knock or pinging persists, see an authorized Honda generator dealer.

**NOTICE** Running the engine with persistent spark knock or pinging can cause engine damage.

Running the engine with persistent spark knock or pinging is considered misuse, and the Distributor's Limited Warranty does not cover parts damaged by misuse.

---

## Oxygenated fuels

Some conventional gasolines are being blended with alcohol or an ether compound. These gasolines are collectively referred to as oxygenated fuels. To meet clean air standards, some areas of the United States and Canada use oxygenated fuels to help reduce emissions.

If you use an oxygenated fuel, be sure it is unleaded and meets the minimum octane rating requirement.

Before using an oxygenated fuel, try to confirm the fuel's contents. Some states/provinces require this information to be posted on the pump.

The following are the EPA approved percentages of oxygenates:

**ETHANOL-** (ethyl or grain alcohol) 10% by volume

You may use gasoline containing up to 10% ethanol by volume. Gasoline containing ethanol may be marketed under the name "Gasohol"

**MTBE-** (methyl tertiary butyl ether) 15% by volume

You may use gasoline containing up to 15% MTBE by volume.

**METHANOL-** (methyl or wood alcohol) 5% by volume

You may use gasoline containing up to 5% methanol by volume as long as it also contains cosolvents and corrosion inhibitors to protect the fuel system. Gasoline containing more than 5% methanol by volume may cause starting and/or performance problems. It may also damage metal, rubber, and plastic parts of your fuel system.

If you notice any undesirable operating symptoms, try another service station or switch to another brand of gasoline.

Fuel system damage or performance problems resulting from the use of an oxygenated fuel containing more than the percentages of oxygenates mentioned above are not covered under warranty.

---

## Air cleaner

Check that the air cleaner elements are clean and in good condition. A dirty air cleaner will restrict air flow to the carburetor, reducing engine performance. A damaged air cleaner will allow dirt to enter the engine, causing rapid engine wear.

1. Open the hood and remove the wing nuts to remove the air cleaner cover and air cleaner elements.
2. Inspect the air cleaner elements. Clean or replace the elements if necessary. If the air cleaner elements need cleaning, follow the procedure described on page 85.
3. Reinstall the air cleaner elements and air cleaner cover. Tighten the wing nuts securely.

**NOTICE** Operating the engine without an air cleaner will cause rapid engine wear.

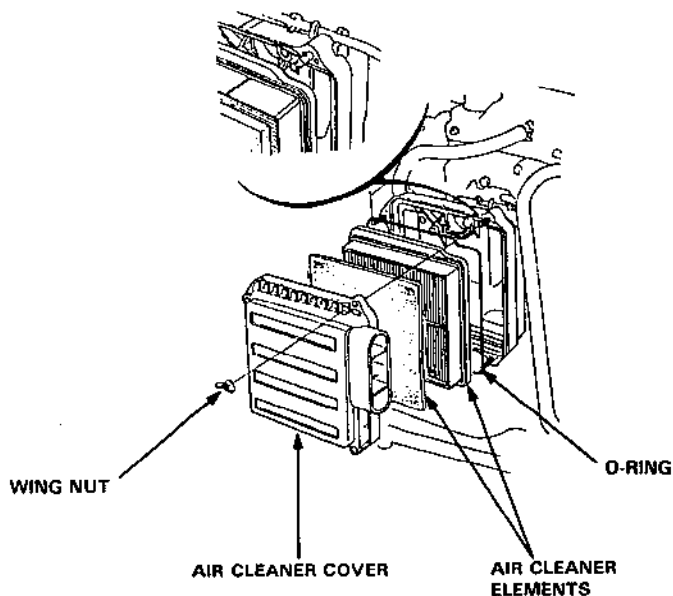

## Coolant

If there is no coolant in the reserve tank, check the cooling system for leaks and repair if necessary.

**▲WARNING** Never remove the radiator cap when the engine is hot. The coolant is under pressure and severe scalding could result.

Add coolant to the radiator and the reserve tank, then check the coolant level in the reserve tank after the engine reaches operating temperature. When the engine is at operating temperature, the coolant level should be between the MIN and MAX marks on the reserve tank. If the level is near the MIN mark, add coolant to bring it up to the MAX mark.

## Coolant Recommendation

Use high quality ethylene glycol antifreeze that is specifically formulated for use in aluminum engines. Mix the antifreeze with low-mineral drinking water or distilled water.

A 50/50 mixture of ethylene glycol antifreeze and water is recommended for most temperatures and provides good corrosion protection. A higher concentration of antifreeze decreases cooling efficiency and is recommended only if additional protection against freezing is needed. A concentration of less than 40% antifreeze will not provide proper corrosion protection.

**NOTICE** The use of unsuitable antifreeze, hard water, or salt water may cause corrosion damage that will shorten the life of the engine.

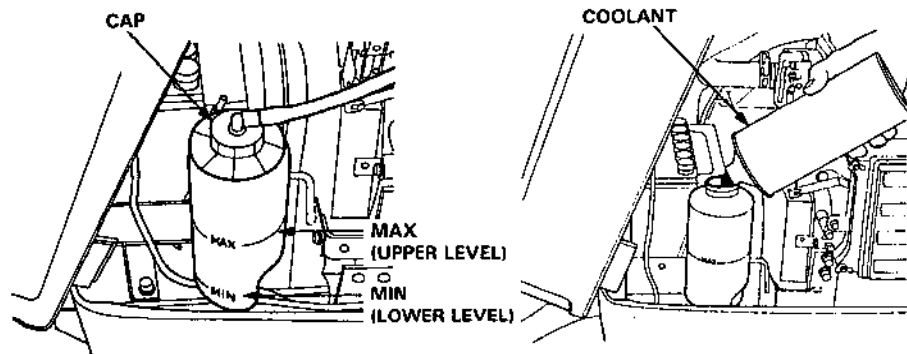

---

## Battery electrolyte level

Open the hood, and check the battery electrolyte level.

The electrolyte level must be kept between the UPPER and LOWER level marks. If the electrolyte level is near the LOWER mark, remove the battery filler caps and carefully add distilled water to each cell until the liquid reaches the upper level line (see page 88).

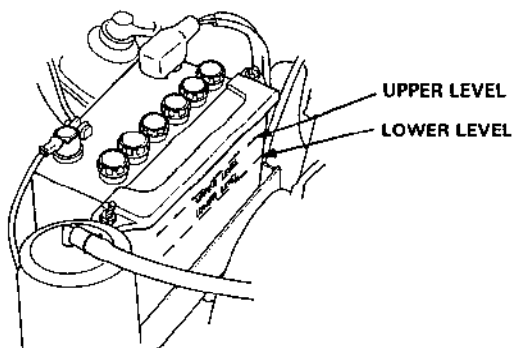

**⚠ WARNING** Batteries produce explosive gases. Flames or sparks can cause an explosion, causing serious injury or blindness. Keep flames and sparks away and provide adequate ventilation when charging.

- **CHEMICAL HAZARD:** Battery electrolyte contains sulfuric acid. Contact with eyes or skin, even through clothing, may cause severe burns. Wear a faceshield and protective clothing.

**ANTIDOTE:** If electrolyte gets into your eyes, flush thoroughly with warm water for at least 15 minutes and call a physician immediately.

- **POISON:** Electrolyte is poison.

**ANTIDOTE**

- External: Flush thoroughly with water.
- Internal: Drink large quantities of water or milk.

Follow with milk of magnesia or vegetable oil, and call a physician immediately.

- **KEEP OUT OF REACH OF CHILDREN.**

## Hydraulic lift system oil leakage inspection

Open the hood, raise the seat, and visually inspect the oil line for cracks or oil leakage with the engine OFF.

If there is any sign of cracks or oil leakage, contact your authorized Honda tractor dealer for service.

**⚠ WARNING** Escaping hydraulic fluid under pressure can penetrate the skin causing serious injury. Avoid checking the oil lines while the engine is running.

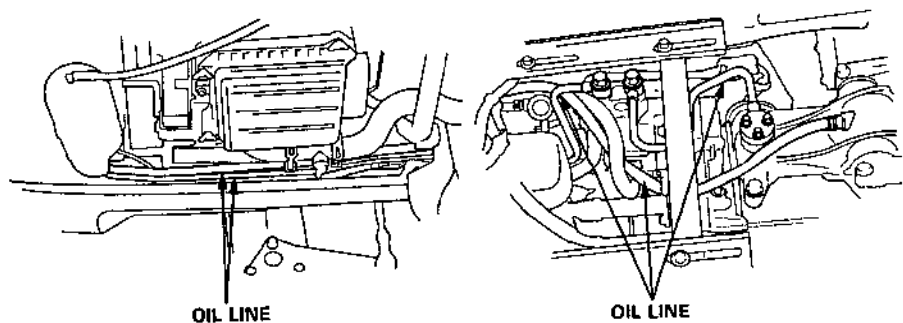

## Front P.T.O. belts

Visually inspect the front P.T.O. belts for wear or damage. If worn or damaged, contact your authorized Honda tractor dealer.

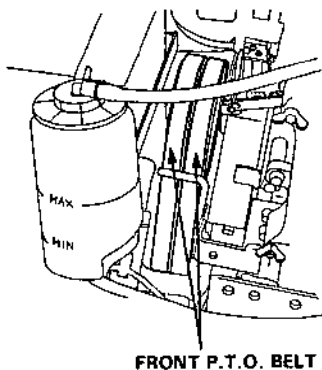

---

### Fan belt

Visually inspect the fan belt for wear or damage. If worn or damaged, contact your authorized Honda tractor dealer to have it serviced.

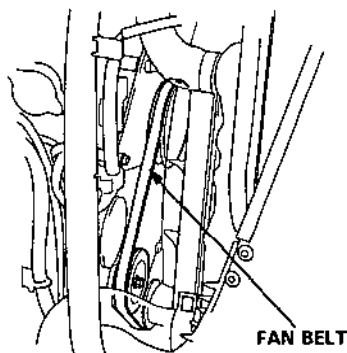

### Brake pedal free play

Measure the brake pedal free play from fully released to the point you can feel the brake begin to take hold. Free play should be 20–30 mm (0.8–1.2 in).

Consult your authorized Honda tractor dealer if free play is out of specification, or the brake does not operate properly.

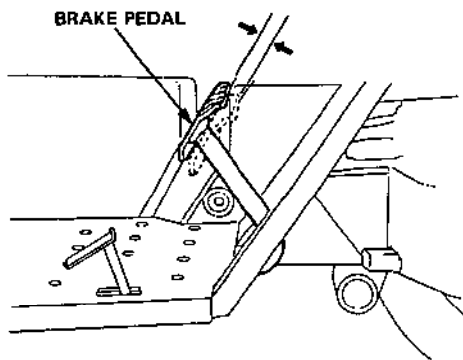

## Brake wear indicator

Inspect brake lining condition every time the tractor is used. Firmly set the parking brake, and then check the position of the brake wear indicator. If the wear indicator line up with right axle tube flange, consult your authorized Honda tractor dealer for repair.

**NOTICE** Under no circumstances should the tractor be operated if the brake lining is at or past the service limit.

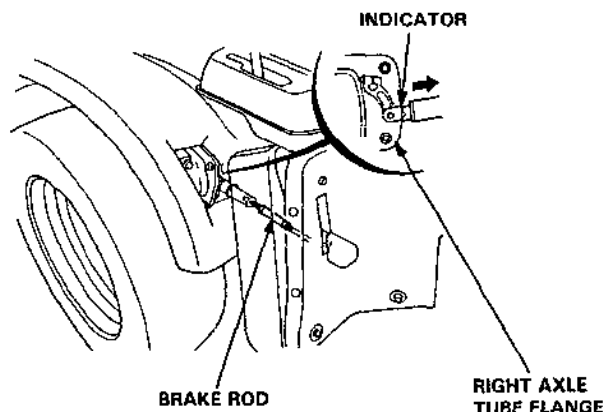

## Clutch pedal free play

Measure the clutch pedal free play from fully released to the point you can feel resistance. Free play should be 2–15 mm (0.08–0.6 in). If free play is out of specification, consult your authorized Honda tractor dealer.

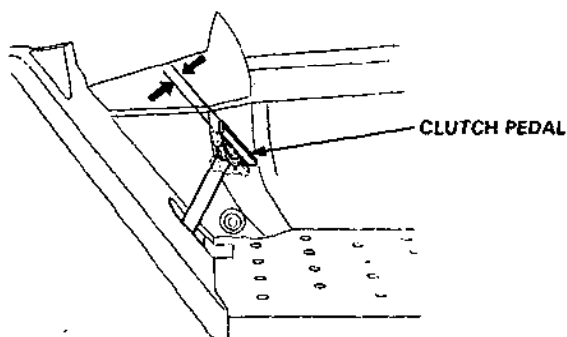



## Tires/wheels

- Check the tire pressure with a pressure gauge.  
Turf tire pressure: Front 1.0 kg/cm<sup>2</sup> (14.2 psi)  
Rear 0.8 kg/cm<sup>2</sup> (11.4 psi)  
AG tire pressure: Front 1.4 kg/cm<sup>2</sup> (19.9 psi)  
2.3 kg/cm<sup>2</sup> (32.7 psi) with heavy attachment  
Rear 1.7 kg/cm<sup>2</sup> (24.2 psi)
- Check that the lug nuts on each wheel are securely tightened.  
Torque: 13 kg-m (94 ft-lb)

**NOTICE** Every day, check the lug nuts daily for security for the first 20 hours of operation, and retighten if necessary. Thereafter, re-check and retighten them every 50 hours.

- Check side wall and tread surface of each tire for cracks, damage, or excessive wear.

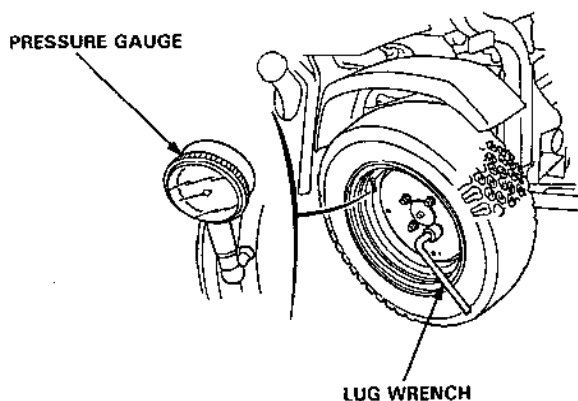

## Hydraulic lift system fluid

**NOTICE** Before performing this inspection, lower the front and rear (option) lift arms fully and confirm they are at their lowest positions. If the tractor is not equipped with any attachment, lower the lift arms by pushing them down by hand with the hydraulic lift lever set in the FAST DOWN position.

Remove the filler cap, wipe off the dipstick and reinsert it until the dipstick is fully seated. Remove it again, and if the level is near the lower level mark, add the specified fluid to the upper level.

**NOTICE** Do not fill the tank beyond the upper level. If this level is exceeded, it will result in an excessive rise in the fluid temperature and overflow of the fluid, and subsequent damage to the hydraulic system. Do not leave the fluid under the lower level.

**Recommended fluid: HONDA power steering fluid**

Use of any fluid other than HONDA power steering fluid, can result in hydraulic system damage.

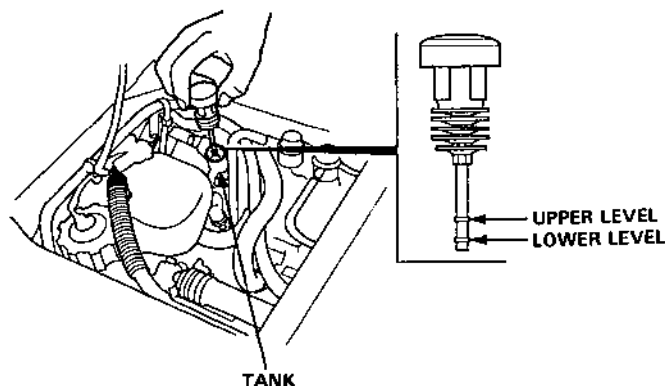

**NOTE:** If the fluid level drops rapidly or repeatedly, the system requires service by an authorized HONDA tractor dealer.

---

## Seat adjustment

Make sure the seat and seat bolts are properly adjusted and securely mounted.

If necessary:

1. Loosen the four seat mounting bolts.
2. Move the seat to a position that allows you to reach all controls easily and comfortably.
3. Tighten the seat mounting bolts securely.

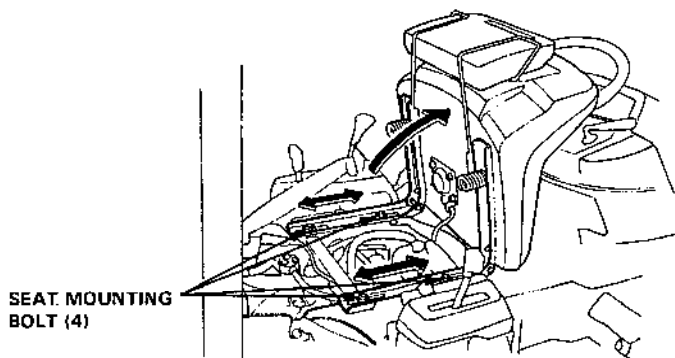

## Steering

Check the steering free play with the wheels straight ahead. There should be less than 30 mm (1.2 in) of steering wheel rotation before the front wheels start to turn.

Push the steering wheel up and down, and in and out; There should be no measurable movement.

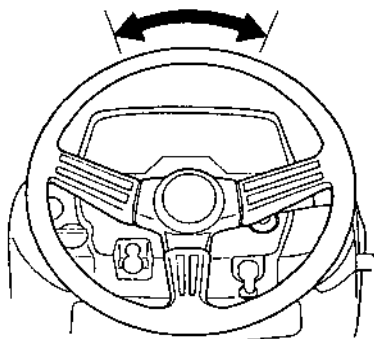

## Parking brake

Make sure that the parking brake and warning buzzer system operate properly. Turn the ignition switch ON but do not start engine, move the main transmission lever to any position (other than NEUTRAL), push the brake pedal and apply the parking brake lock lever.

PARKING BRAKE WARNING BUZZER

PARKING BRAKE LOCK LEVER

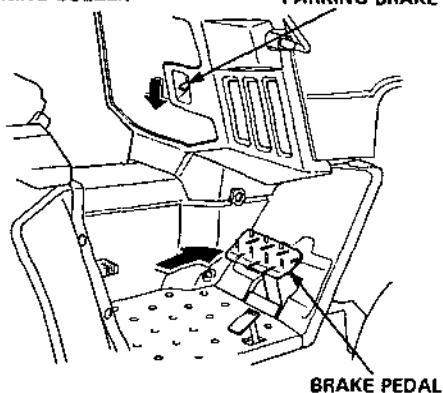

## Headlight

Turn the engine switch ON and check the headlight by operating the headlight switch.

HEADLIGHT SWITCH

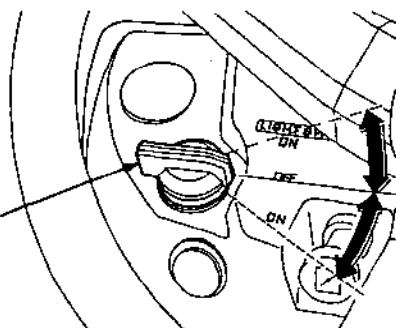

## Safety interlock system

**▲WARNING** Before inspecting, ensure that the area in front of and behind the tractor is clear of people, pets and obstacles.

This tractor is equipped with a series of inhibitor switches which prevent the engine from being started unless the proper operating procedures are followed. Observe the following procedures to check the inhibitor switches.

**▲WARNING** Do not operate the tractor if there are any abnormalities in the system, or in the operation of the switches. An accident or severe personal injury could result.  
Consult your authorized Honda tractor dealer.

To check the system, sit in the seat, and lock the parking brake.

To prevent accidental engine start up, be sure to remove the spark plug caps from the spark plugs when performing the inspection procedures 1 to 3.

### — 1. Neutral switch

- (1) Move the front and rear P.T.O. levers to the OFF position.
- (2) Place the main transmission lever in "1" or "2."
- (3) Depress the brake pedal enough to release the parking brake.
- (4) With the brake pedal and clutch pedal held down, turn the engine switch (ignition switch) key to START. The starter should not operate.
- (5) Put the main transmission lever into NEUTRAL.
- (6) Return the engine switch (ignition switch) key to OFF.

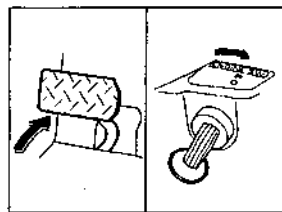
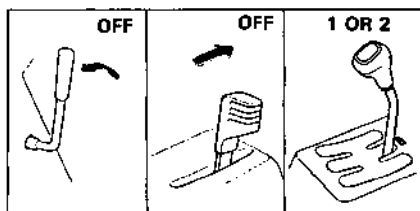

— 2. Front P.T.O. switch

- (1) Move the main transmission lever to NEUTRAL, and the rear P.T.O. lever to OFF.
- (2) Move the front P.T.O. clutch lever to ON.
- (3) Turn the ignition switch key to START. The starter should not operate.
- (4) Move the front P.T.O. clutch lever OFF.
- (5) Return the engine switch (ignition switch) key to OFF.

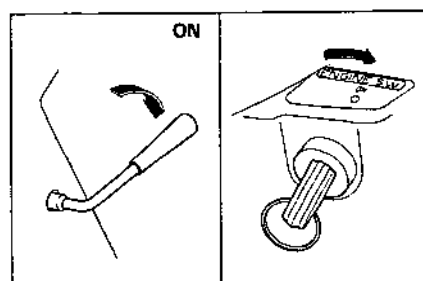
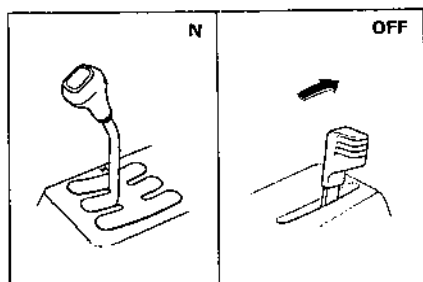

— 3. Rear P.T.O. switch

- (1) Move the main transmission lever to NEUTRAL, and the front P.T.O. clutch lever to OFF.
- (2) Move the rear P.T.O. lever to ON.

NOTE: If difficulty is encountered in shifting the rear P.T.O. lever, operate the starter momentarily by turning the ignition switch key to START. Do not depress the clutch pedal during this operation.

- (3) Turn the ignition switch key to START. The starter should not operate.
- (4) Move the rear P.T.O. lever OFF.
- (5) Return the ignition switch key to OFF.

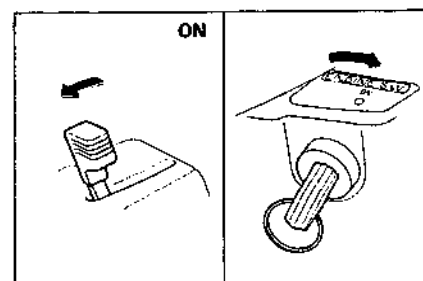
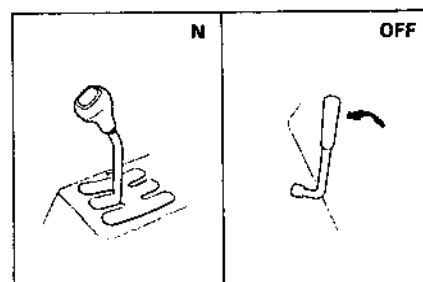

– 4. Seat switch

**NOTE:** To make this inspection, it is necessary to start the engine. Attach the spark plug cap to the spark plug securely. To start, refer to the procedures described on Page 47.

- (1) Lock the parking brake and put the main transmission lever in NEUTRAL.
- (2) Move the front and rear P.T.O. levers OFF.
- (3) Start the engine.
- (4) Move the P.T.O. lever free of either front or rear attachment to ON position.
- (5) Rise up slightly off the seat. The engine should stop as soon as your weight leaves the seat.
- (6) Return the front P.T.O. lever to OFF and turn off the ignition switch key.
- (7) Repeat for rear P.T.O.

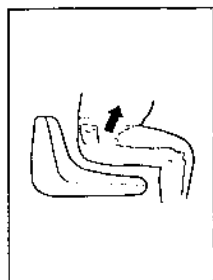
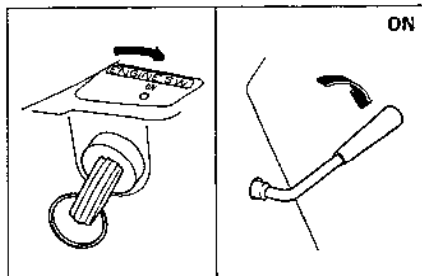

– 5. Oil pressure indicator light

**NOTE:** To make this inspection, it is necessary to start the engine. Attach the spark plug cap to the spark plug securely. To start, refer to the procedures described on Page 47.

- (1) Lock the parking brake and put the main transmission lever in NEUTRAL.
  - (2) Move the front and rear P.T.O. levers OFF.
  - (3) Start the engine.
- After starting the engine, check the oil pressure indicator light to see that it goes on, for few seconds and then goes out.

Return the ignition switch key to OFF.

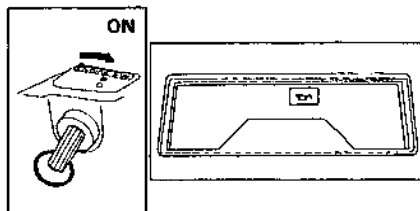
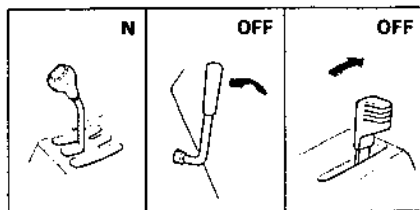

---

## Hydraulic lift system

### NOTE:

- To make this inspection, it is necessary to start the engine; refer to the procedures described on Page 47.
  - This inspection should be made with an attachment mounted on the tractor.
  - The check procedure is the same for the front or rear attachment lifts. Check either, by selecting the appropriate hydraulic cylinder selector lever position.
- (1) Start the engine.
  - (2) Set the hydraulic cylinder selector lever in FRONT or REAR (option).
  - (3) Move the lift lever to FAST or SLOW UP position, then release your hand from the lever.

Check that the lift lever returns to NEUTRAL.

- (4) Check that the attachment is lowered when the lift lever is moved to the DOWN or SLOW DOWN position.
- (5) Check the descent speed and adjust descent speed if necessary, see page 27.



## 6. OPERATION

### 1. Starting the engine

**⚠ WARNING** Exhaust contains poisonous carbon monoxide gas that may cause loss of consciousness and lead to death. Never run the engine in an enclosed area. Be sure to provide adequate ventilation.

1. Sit on the seat and check that the parking brake lock lever is set.
2. Make sure the main transmission lever is in NEUTRAL, both the front (option) and rear P.T.O. levers are OFF and the lift lever is in the center (Neutral) position.

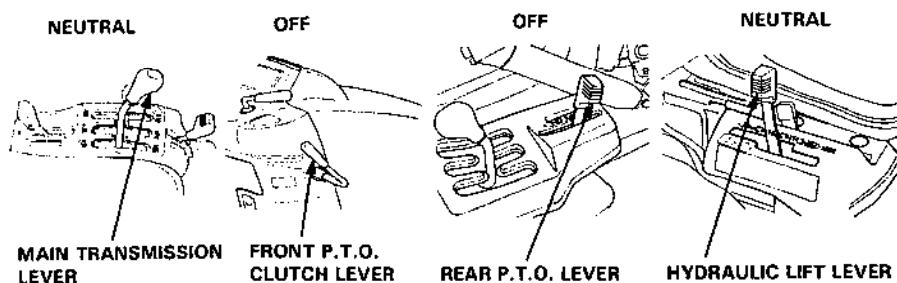

3. Pull the choke knob all the way out and move the throttle lever to the middle (1/2) position.

**NOTE:** The choke may not be needed if the engine is warm or the air temperature is high.

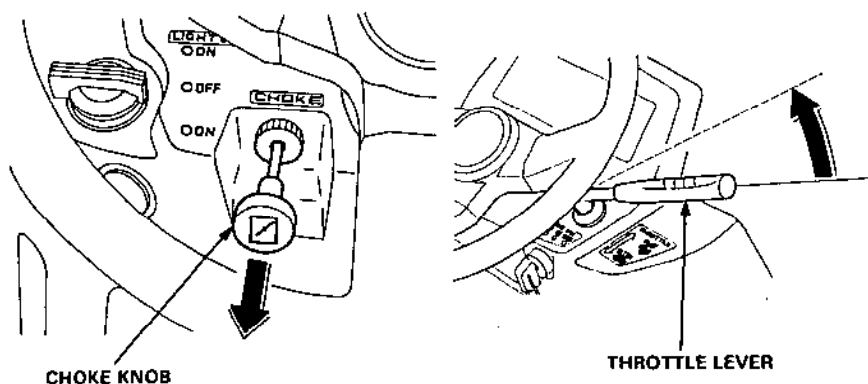

4. Turn the engine switch (ignition switch) key to "START" and release the key when the engine starts.

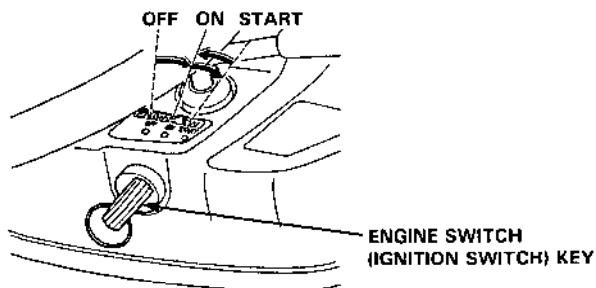

**NOTICE** Running the starter motor for more than 5 seconds can damage the motor.

If the engine fails to start, release the engine switch (ignition switch) key, and wait at least 10 seconds before operating the starter motor again.

5. As the engine warms up, gradually push the choke knob to the OFF position.

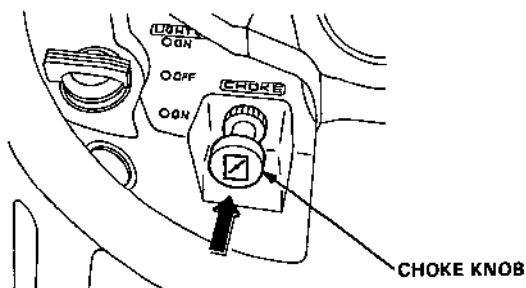

6. As the engine stabilizes, gradually move the throttle lever to the SLOW position.

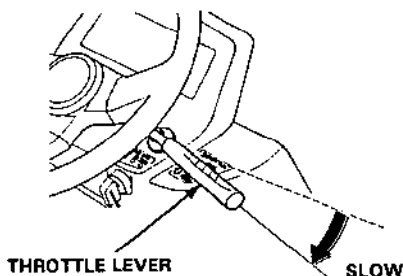

## 2. Starting/driving

**▲WARNING** Before operating the Tractor or its attachments, read and understand the tractor safety instructions (pages 6–9).

### – 1. Wearing the seat belt.

**▲WARNING**

- Wear the seat belt whenever operating the tractor with the Rollover Protective Structure attached.
- Use of either device (seat belt or ROPS) without the other will increase the chance of injury in a rollover.

Make sure that the seat belt is not twisted or kinked.

Push the tongue plate into the buckle until it clicks.

Sit erect and well back in the seat. Then adjust the belt to a snug fit by pulling out on the ends of the belt so the buckle is at the center of your body.

To release the seat belt, pull up on the buckle latch and pull out the tongue plate.

**▲WARNING** Be sure that the belt is not twisted before fastening. The seat belt should be adjusted as snug as possible to provide proper protection.

TONGUE PLATE

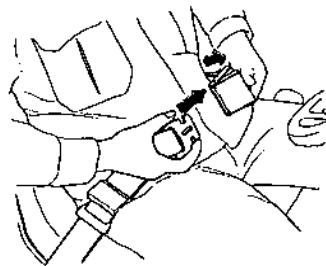
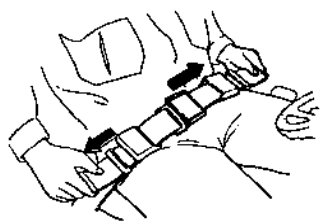
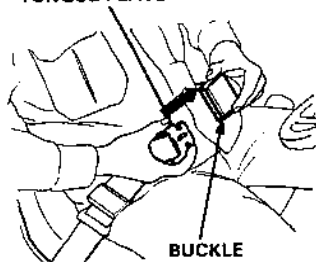

- 
2. Depress the clutch pedal and place the main and auxiliary transmission levers in the desired gear range for operation.

**NOTE:** When the main transmission lever is engaged, a warning buzzer will sound to notify the driver if the parking brake is applied.

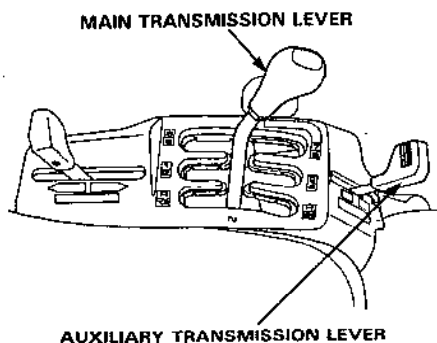
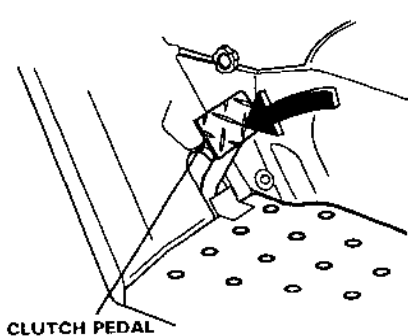

3. Depress the brake pedal and release the parking brake lock lever.

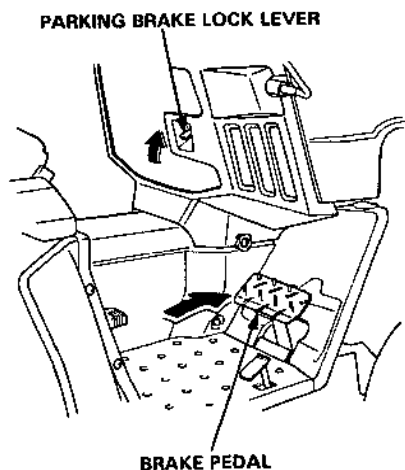

4. Raise the throttle lever slightly and slowly release the clutch pedal.

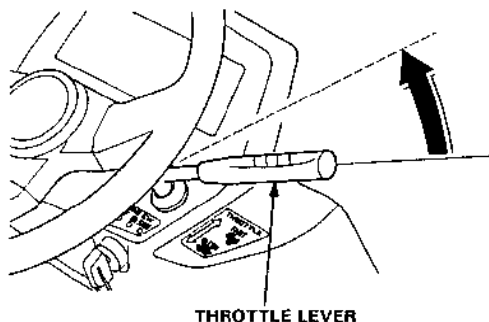

**WARNING** Always release the clutch pedal slowly when starting the tractor in motion. Sudden starts can damage the equipment or cause loss of vehicle control that may result in severe personal injury. Do not start out suddenly or with the steering wheel turned to one side.

**NOTICE** Do not rest your foot on either the clutch pedal or differential lock pedal while the tractor is in motion. This can cause premature wear or damage of the clutch and differential lock.

### 3. How to use the differential lock (A4 type only)

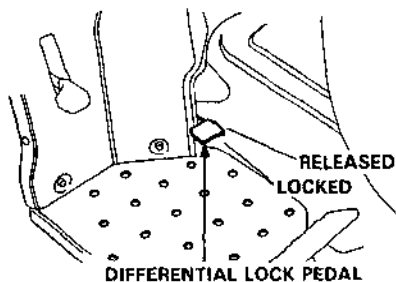

**⚠ WARNING** When used properly, the differential lock is extremely convenient. However, improper operation could cause the vehicle to overturn; it could also damage the drive train. Take care when using the differential lock.

The differential lock is most useful in situations where a slippery or loose surface causes one of the rear wheels to lose traction.

#### Operation

1. Shift the main transmission lever into 4th or lower gear range.
2. With the steering wheel held straight-ahead, depress and hold the differential lock pedal. As long as you continue to depress the pedal, the differential lock will be applied.
3. The differential lock should release when the differential lock pedal is released.  
At times it may be necessary to stop, reverse direction, and drive a short distance to disengage.

- 
3. To release the differential lock, remove your foot from the lock pedal, bring the tractor to a full stop, shift the main transmission from FORWARD to REVERSE or vice versa, and drive a short distance.

**▲WARNING** The differential lock must be released before operating the tractor on hard surfaces or slopes, or while turning. Otherwise the tractor may overturn, causing severe personal injury.

**NOTICE**

To avoid damage to transmission mechanism.

- Do not apply the differential lock while the wheels are turning.
- Do not rest your foot on the differential lock pedal unless you want to engage the differential lock.
- Do not apply the brake and the differential lock at the same time.
- Check that the differential lock has been released after you have finished using it.
- Do not apply the differential lock while driving at high speed.
- Do not apply the differential lock on a hard packed surface.

#### 4. Two and four-wheel drive selection (A4 type only)

Two or four wheel drive can be selected by operating the two/four wheel drive select lever.

Prior to shifting, set the steering wheel in the straight-ahead position, bring the tractor to a complete stop and depress the clutch pedal fully.

**NOTE:** If difficulty is encountered in shifting the lever, re-engage the gears by driving the tractor a short distance in FORWARD with the clutch engaged.

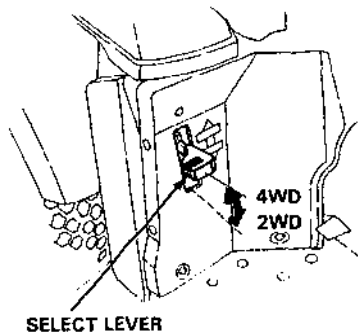

We recommend that you select the two wheel drive or the four wheel drive according to the terrain and conditions.

2-WHEEL DRIVE .....	Mowing and transport (when extra traction is not required)
4-WHEEL DRIVE .....	Towing, Operation on slope or soft ground, Operation with attachment installed (Especially when powerful driving force and braking force are required.)

#### NOTICE

- To prevent damage to the transmission mechanism, bring the tractor to a full stop before operating the shift lever.
- Driving in 4-wheel drive range or application of the differential lock on paved road or surface could cause premature wear on the tires; it could also impair fuel economy.
- When driving in four wheel drive, you have 4-wheel braking. When shifted into two wheel drive you have 2-wheel braking (rear only).



## 5. Turning

This tractor has Four Wheel Steering, read the following information carefully.

**▲WARNING** Turning the tractor at excessive speed especially on uneven terrain can cause the tractor to tip over and you can be injured. Slow down before turning.

To prevent accidental tip over:

- Never make abrupt starts while the wheels are turned.
- Slow down before making sharp and/or hard turns.
- Avoid sharp turns in rutty or uneven terrain.
- Engaging the differential lock while making sharp turns can cause you to lose steering control.
- Be sure to raise ground engaging attachments (rotary tillers, disk harrows, moldboard plows, etc.), before executing sharp turns. If the attachment is not raised, you can damage the tractor and/or the attachment.

### NOTICE

- Rear attachments swing out in a larger arc than the tractor, and can strike nearby objects.
- Use care when turning the tractor near a wall or other obstructions when a rear mounted attachment is being used. 4-wheel steering allows the tractor to turn in a very small radius.

Explanation of 4-Wheel Steering

- Steering wheel in straight ahead position:

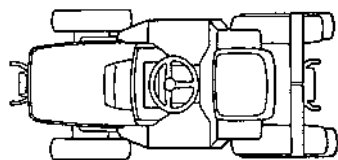

- When the steering wheel is turned, the rear wheels will be turned in a direction opposite to the front wheels and continue to be turned in that direction until the steering wheel is turned to the extreme position.

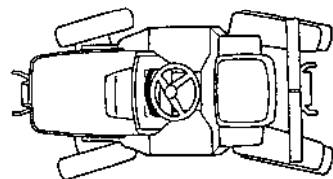

## 6. Attachment limitations

Use of Honda attachments is recommended. If an attachment exceeds the limits shown below or it is not suited to H5518, or if the counterweights used do not conform to the sizes and weights specified in "Counterweight Table", they may not only endanger operators or equipment but also prevent you from taking the fullest advantage of your tractor.

Never use attachments which exceed sizes and weights specified.

Never use counterweights other than those specified in Counterweight Table.

Any malfunction or damage to the tractor is unwarrantable if it is the consequence of use of attachments not specified or recommended by Honda.

### • Attachment Limitations

Max. allowable load at end

of lower link .....

Attachment weight .....

Trailer load .....

Tongue weight .....

Max. lifting force at lift point: W0

Max. attachment weight which

can be lifted hydraulically: W1

Total weight of trailer and max.

allowable load on trailer: W2

Total weight or downward force  
on pivot point: W3

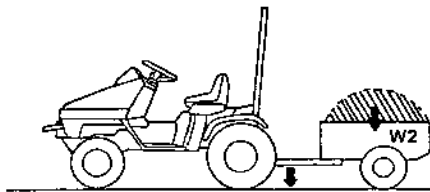
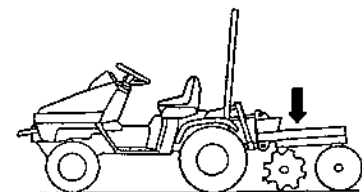
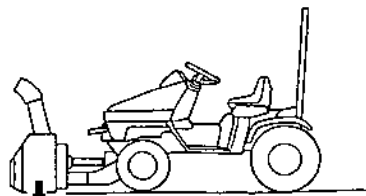
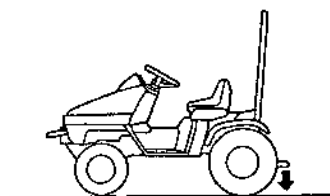

Max. load at lower link end (W0)		250 kg (551 lbs)	Installation should be based on "COUNTERWEIGHT TABLE." (see page 58)
Max. weight of attachment (W1)		140 kg (309 lbs)	
Trailer	Max. load (W2)	363 kg (800 lbs)	Weight of trailer included
	Tongue weight (W3)	20 ± 9 kg (45 ± 20 lbs)	As down force

### Size and Weight Limits by Attachments

Attachment		Item	Weight and Size Limits
Rotary Mower	Mid 3-blade	Max. cutting width	1,168 mm (46 in.)
		Max. weight	60 kg (132 lbs)
		Max. cutting width	1,320 mm (50")
		Max. weight	120 kg (264 lbs)
Snow Blower		Max. intake width	1,070 mm (42 in.)
		Max. weight	100 kg (220 lbs)
Snow Dozer		Max. blade width	1,170 mm (46 in.)
		Max. weight	50 kg (110 lbs)
Rotary Tiller		Max. cultivating width	1,070 mm (42 in.)
		Max. weight	140 kg (309 lbs)
Plow		Max. size	300 mm (12 in.) x 1
Disc Harrow		Max. cultivating width	1,320 mm (52 in.)
		Max. weight	100 kg (220 lbs)
Cultivator		Max. size	1,220 mm (48 in.) (single row)
Trailer		Max. load	363 kg (800 lbs) (weight of trailer included)
Sweeper		Max. size	1,194 mm (47 in.)
		Max. weight	89 kg (196 lbs)
Front end Loader		Bucket width	1,016 mm (40 in)
		Max lift capacity	182 kg (400 lbs)
		Max weight	250 kg (550 lbs)
Front-Mount Rotary Mower		Max. cutting width	1,168 mm (46 in)
		Max. weight	76.5 kg (169 lbs)

NOTE: The above limits are applicable if only one attachment is used on the tractor.

---

- Towing

**▲ WARNING**

- Never attempt to tow anything without a trailer hitch. Failure to use a proper hitch could cause the tractor to overturn resulting in severe personal injury or equipment damage.
- Never allow anyone to ride in the trailer.
- Traveling and turning at high speeds while towing a trailer or other attachment is dangerous. Use 1st gear when towing a trailer or attachment over rough ground.
- Avoid sudden starts and stops while towing. The momentum of the trailer or attachment could cause loss of control resulting in an accident and severe personal injury or equipment damage.
- The weight of a trailer increases stopping distances; use extra care, especially when operating on a slope.

Use only those attachments which are designed for the use with this vehicle (Category O). If you have any questions or doubts about the suitability of any other attachments, consult your authorized Honda tractor dealer.

**NOTICE**

The removal of any rear attachment is necessary when using the draw plate for towing. If the rear attachment is not removed, damage to the tractor and/or the attachments can occur.

1. Maximum towing weight:  
363 kg (800 lbs) including the weight of the trailer.

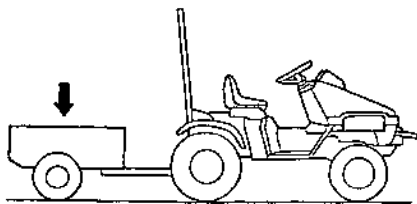

**▲ WARNING**

Exceeding the maximum towing weight could lead to loss of control and cause an accident resulting in severe personal injury or equipment damage.

- 
2. Maximum tongue weight:  
20 kg  $\pm$  9 kg (45 lbs  $\pm$  20 lbs)

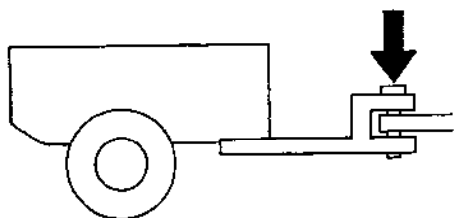

**▲ WARNING** If the trailer's load is unbalanced so that the tongue weight is incorrect, the tractor may overturn resulting in severe personal injury or equipment damage.

**NOTE:** Tongue weight is the downward force that the trailer exerts on the trailer hitch.

## • Counterweight

When an attachment is fitted to the FRONT or REAR, the weight balance between front and rear wheels is lost, which may lead to instability while the vehicle is running (front wheel lift, etc.). To avoid this, it is necessary to fit a counterweight to regain front-rear wheel balance.

Make suitable counterweight settings according to the list below.

**⚠ WARNING** Under no circumstances should the total weight of the attachment, counterweights and wheel weights exceed 350 kg (780 lbs). Failure to follow this precaution may endanger yourself, and may cause damage to your tractor or shorten its service life.

The total number of the counterweights needed for each Honda attachment are shown in the table below.

Attachment	Manufacture type name	Number of counterweights/recommended tire			
		4WD		2WD	
		counterweights	tire	counterweights	tire
Mid-Mount Rotary Mower	HONDA 46"	None	Turf	None	Turf
	HONDA 52"	None	Turf	None	Turf
Front Snow Blower	BER-VAC 42"	Rear: 8	AG	Rear: 8	AG
Front Dozer Blade	BER-VAC 54"	Rear: 5	AG	Rear: 8 or rear wheel weight: 2 (one for each rear wheel)	AG
Front Sweeper	BER-VAC 42"	Rear: 8	AG	Rear: 8	AG
Tiller	Bush-Hog 40"	Front: 4	AG	Front: 4	AG
Plow	BRINLY PP-1200	None	AG	Rear wheel Weight: 2 (one for each wheel)	AG
Disc Harrow	BRINLY DD-1000	None	AG	Rear wheel weight: 2 (one for each wheel) and front weight: 1	AG
Cultivator	BRINLY 40"	None	AG	None	AG
Front end Loader	KWIK-WAY 400 lbs	Rear: 12 counterweights 17 kg (37.5 lbs)	AG	Not to be used	AG

Attachment	Manufacture type name	Number of counterweights/recommended tire			
		4WD		2WD	
		counterweights	tire	counterweights	tire
Trailer	—	None	AG	Rear wheel weight: 2 (one for each wheel)	AG
Front-Mount Rotary-Mower	HONDA 46"	Rear: 8	Turf	Rear: 8	Turf

**NOTE:**

- In this table, the calculation is based on the assumption that the weight of each counterweight is about 11 kg (25 lb), and the weight of each rear wheel is about 20 kg (44 lb), respectively.
- Use of turf tires on the front end loader or agricultural tires on the front/mid mower is not recommended as such practice may affect the performance of the equipment.

Use the table below and determine the number of the counterweights for the attachments other than listed in the previous page.

**1. Rear Attachment and Counterweight Table.**

The number in the box indicates the number of counterweights required.

**NOTE:** This table is based on each counterweight weighing approximately 11 kg (25 lbs).

W \ L	600 mm (24 in)	800 mm (32 in)	1,000 mm (39 in)	1,200 mm (47 in)
40 kg (88 lbs)	0	0	0	1
60 kg (133 lbs)	0	0	1	2
80 kg (178 lbs)	0	1	2	3
100 kg (222 lbs)	1	2	3	4
120 kg (267 lbs)	2	3	4	5
140 kg (311 lbs)	3	4	5	*

0: Counterweight unnecessary

\*: Attachment should not be used

L: Distance between center of attachment side wheel and center of gravity of attachment.

W: Weight of attachment

C.G.: Center of gravity

Any attachments which exceed the sizes and weights shown in the table to the left should not be used.

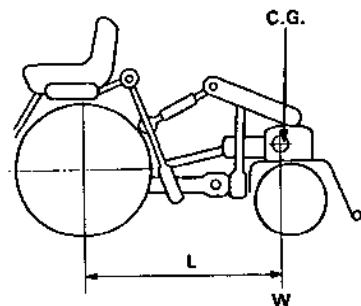

## 2. Front Attachment and Counterweight Table

The number in the box indicates the number of counterweights required.

**NOTE:** This table is based on each counterweight weighing approximately 11 kg (25 lbs).

W \ L	600 mm (24 in)	800 mm (32 in)	1,000 mm (39 in)	1,200 mm (47 in)	1,400 mm (55 in)
60 kg (133 lbs)	1	2	3	5	5
80 kg (178 lbs)	3	5	6	7	
100 kg (222 lbs)	5	7	8		
120 kg (267 lbs)	7	8			
140 kg (311 lbs)	8				

\* Attachment should not be used.

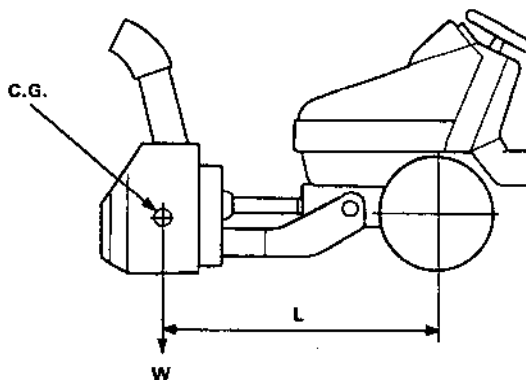



## 7. Driving on a slope

Before starting up or down a long incline, select one of the lower gear ranges, so that tractor speed is reduced, but engine speed is high for maximum control.

### ⚠ WARNING

- Driving across the face of a slope can cause the tractor to tip over and you can be injured. Always drive up or down a slope.
- Making turns on a slope can cause the tractor to tip over and you can be injured. Drive straight up or straight down slopes.
- Changing gears while driving on a slope can cause loss of control. Shift to a lower gear before approaching a slope.
- Engagement of the differential lock while driving on a slope can cause loss of control.
- Avoid parking on a slope. If necessary, apply the parking brake and place blocks on the downhill side of each wheel.

Refer to the table below for driving on a slope.

Typical Attachment	Without ATT	Mid ATT	Rr ATT	Fr ATT	Towing
Condition	Tractor	Mid-mount Rotary Mower	Rear Tiller	Front Snow Thrower	Trailer
Counter-weight and Wheel Weight	* See topic under COUNTERWEIGHT				
Towing Load	—	—	—	—	450 lb (200 kg) (Trailer included)
Max. Speed	6th (5.3 km/h, 3.3 MPH)				
Direction of Travel (UP and Down)	Travel only	Travel and mowing	Travel only. Do not work	Travel only. Do not work	Do not stop on a slope

---

## UPHILL STARTING PROCEDURE

If possible avoid stopping the tractor while driving uphill. If it is necessary to stop on a hill, follow the special procedure below when restarting:

### **▲ WARNING**

- If this procedure is not followed when restarting on an uphill slope the tractor may roll backwards during clutch engagement, and this could cause it to tip over resulting in severe personal injury.
  - Abruptly applying the brake pedal while the tractor is rolling backwards down a slope may cause the tractor to tip over.
- 1. Depress the brake pedal and hold it down.
  - 2. Move the throttle lever to "FAST" position.
  - 3. Depress the clutch pedal and then move the transmission lever to 1st gear position.
  - 4. Release the clutch pedal first, then release the brake pedal.

### **▲ WARNING**

If the brake pedal is released before the clutch pedal, the tractor may go back down. Never make hard braking. It may cause the tractor to tip over.

## 7. Special Obstacles:

- 1. To safely cross drainage ditches or embankments, use a ramp to reduce the effective angle of the obstacle to less than  $15^\circ$

NOTE: If you feel that you cannot accurately judge angle of the ramps, we suggest that you obtain an inclinometer. This type of gauge is available at most hardware stores.

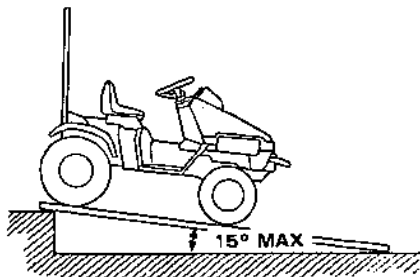

- 2. Avoid swampy or muddy areas deep enough to reach the center line of the wheels. The tractor can become stuck, especially if it is carrying attachments.

---

## 8. Stopping the engine

- In an emergency:  
Turn the engine switch (ignition switch) OFF.  
Depress the clutch and brake pedal.
- In normal use:
  - 1. Move the throttle lever to "SLOW."

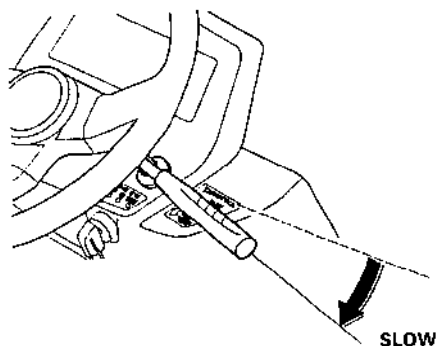

- 2. Depress the clutch and brake pedals simultaneously.  
Move the main transmission lever to "NEUTRAL".

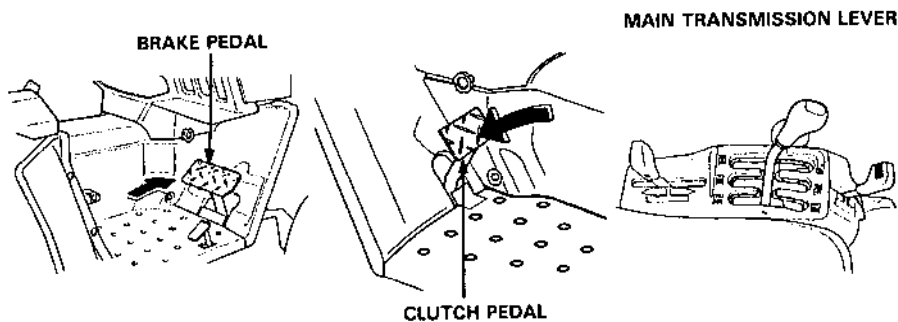

- 
- 3. Shift the front and rear P.T.O. levers to the "OFF" position.

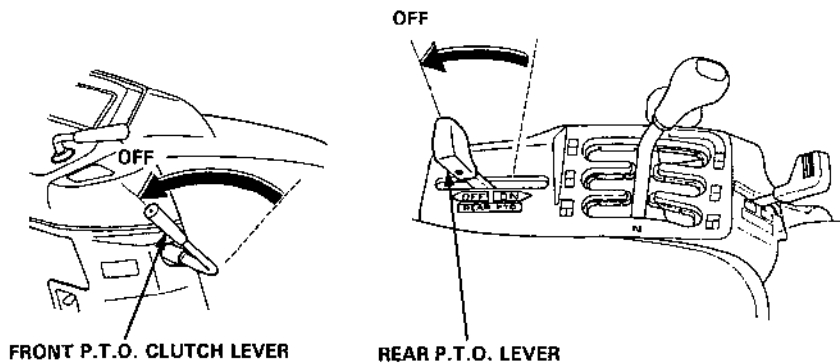

- 4. Lower any attachment to the ground with the hydraulic lift lever.

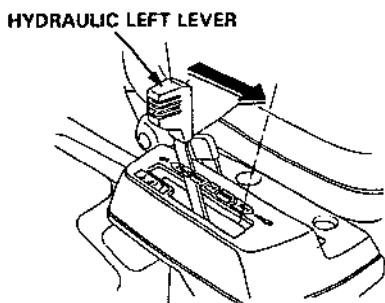

- 5. Turn the engine switch (ignition switch) to "OFF" and remove the key.

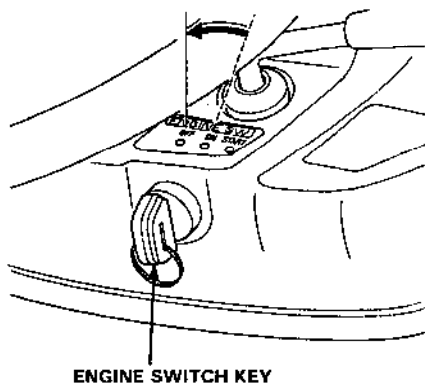

- 
- 6. Push down the park brake lock lever while depressing the brake pedal.

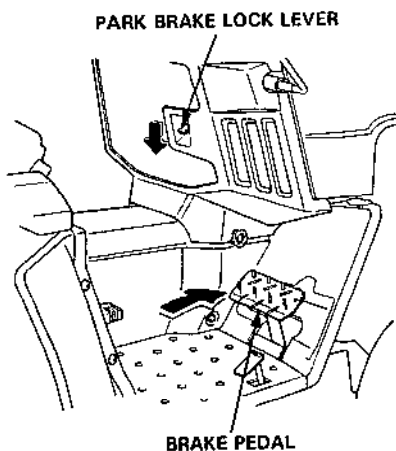

**▲ WARNING** To avoid injury to yourself and others, before leaving the tractor unattended, **ALWAYS:** park on level ground, disengage the power take-off (P.T.O.), lower the attachment, set the parking brake, stop the engine and remove the key.

## 9. Recommended working speed

Select a safe and correct operating speed as per the instructions shown in the chart below.

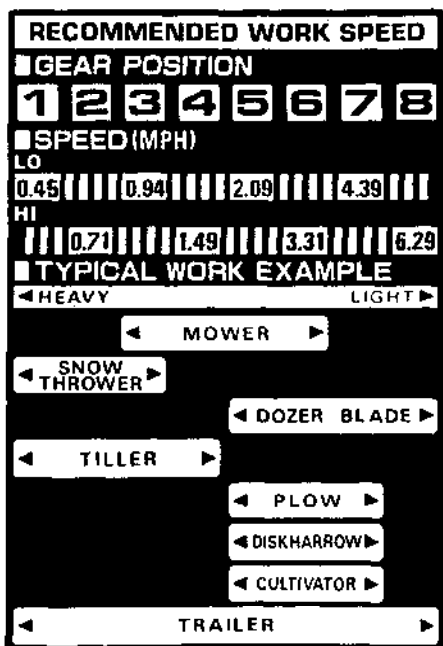

---

## 10. High altitude operation

At high altitude, the standard carburetor air-fuel mixture will be too rich. Performance will decrease, and fuel consumption will increase. A very rich fuel mixture may also foul the spark plugs and cause hard starting.

High altitude performance can be improved by specific modifications to the carburetor. If you always operate your engine at altitudes above 1,800 meters (6,000 feet), have your dealer perform this carburetor modification.

Even with carburetor modification, engine horsepower will decrease about 3.5% for each 300 meter (1,000 foot) increase in altitude. The effect of altitude on horsepower will be greater than this if no carburetor modification is made.

### **NOTICE**

**When the carburetor has been modified for high altitude operation, the air-fuel mixture will be too lean for low altitude use. Operation at altitudes below 1,800 meters (6,000 feet) with a modified carburetor may cause the engine to overheat and result in serious engine damage. For use at low altitudes, have your dealer return the carburetor to original factory specifications.**

## 7. TRANSPORTING

---

### Transporting

**▲WARNING** The engine and exhaust system become hot during operation and remain hot for a while after stopping. Contact with hot engine components or the exhaust system can cause burns and can ignite some materials.

Avoid touching the engine or exhaust system for at least 15 minutes after the engine has stopped. Allow the engine to cool before transporting the tractor.

**NOTICE** Towing the tractor behind another vehicle or using it to push another vehicle can damage the tractor.

Transport the tractor on a flat, heavy duty trailer. To avoid gasoline spillage, keep the tractor level while transporting.

**▲WARNING** Gasoline is extremely flammable, and gasoline vapor can explode, causing injury or death.

Transport the tractor on a flat, level heavy duty trailer.

Some attachments such as the mid-mount rotary having a little load clearance may hit against the end of the ramp when loading onto the truck bed. Place a wood block on the bed close to the ramp so they will not hit against the end of the ramp when loading.

1. Use a loading ramp that is strong enough to support the combined weight of the tractor, its attachments and the operator. The loading ramp must be long enough so that its slope is  $15^\circ$  or less.
2. Use reverse gear 1st or 2nd to back the tractor up the ramp.

**NOTE:** If you feel that you cannot accurately judge angle of the ramps, we suggest that you obtain an inclinometer. This type of gauge is available at most hardware stores.

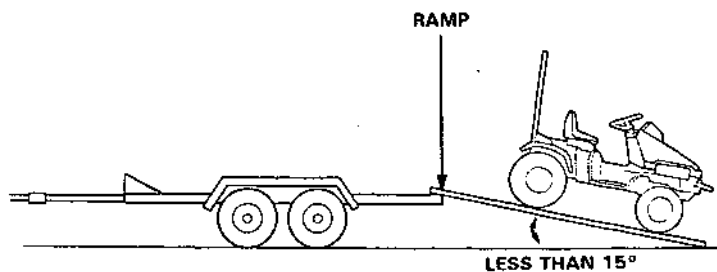

**NOTE:** If the engine stalls during loading, immediately depress the brake pedal and clutch pedal, then let the tractor roll down the ramp by slowly releasing the brake pedal.



- 
3. After loading, apply the parking brake and remove the engine switch (ignition switch) key.
  4. Tie the tractor down securely.

Tie-down hooks should be on or near the floor. Use the tie-down points shown below.

**NOTICE**

- Use heavy-duty restraints such as chains, or cables to fasten tractor to the trailer. Both front and rear restraints must be directed down and outward from tractor.
- To avoid damaging the tie rods, be careful not to put the restraints around or near them when securing the front end.

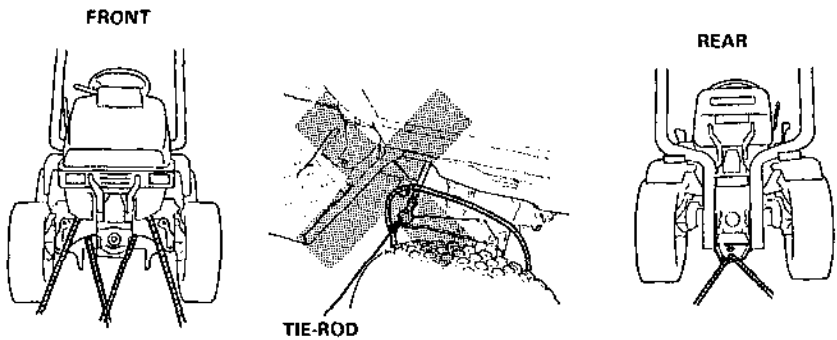

## 8. INSTALLING AN ATTACHMENT

---

Before installing or using any attachment, carefully read all instructions and precautions.

**⚠ WARNING** To prevent accidental start-up, remove the engine switch (ignition switch) key, and disconnect the spark plug caps before installing or adjusting attachments.

### 1. Rear 3-point hitch link installation (option)

- 1. Install the hitch box on the tractor with the six bolts and nut nuts.
- 2. Attach the check links to the right and left lower links with the check links pins and secure with the cotter pins.
- 3. Install the right and left lower links to the hitch box section with lower link pins.
- 4. Insert the check links to the outside of the lower link pin and secure with a lock pin.
- 5. Attach the lift rod pin to the lift arm.
- 6. Install the right side of the lift rod (with the turnbuckle attached) to the right sides of the lower link and lift arm.  
Fit the left side of the lift rod to the left sides of the lower link and lift arm and secure all attachments with pins.
- 7. Install the upper link on the cylinder mounting plate with the four bolts.
- 8. Install and secure the upper link with the link and lock pins.
- 9. Check that all parts are installed securely. Tighten the nuts to the specified torques.

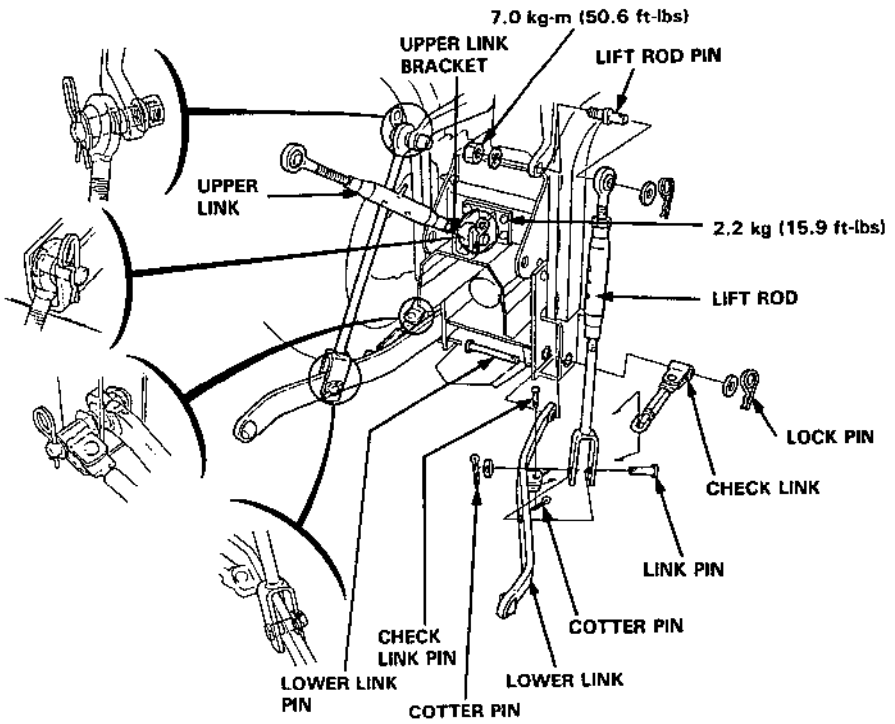
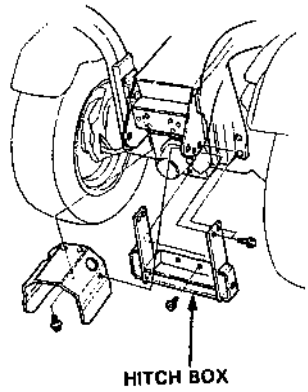

## 2. Rear 3-point hitch attachment installation

Park the tractor on firm, level ground, set the parking brake, and move the shift lever to "N (Neutral)". Set both front and rear P.T.O. levers to the "OFF" when installing, adjusting or removing an attachment.

**⚠ WARNING** Installing, adjusting or removal of an attachment with the engine running is dangerous and you can be injured. Remove the key from the ignition, and disconnect the spark plug caps to prevent start-up.

- a. Place the hydraulic switch lever to "REAR", place the lift lever in the "DOWN" position and fully lower the lower link.
- b. Slacken the check links and open the lower links as necessary.

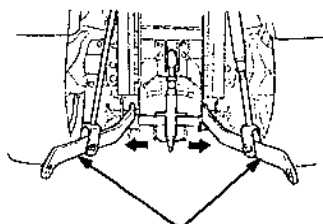

LOWER LINK

TURNBUCKLE ADJUSTER

- c. Install the lower link on the left side first, then the right side using the turnbuckle adjuster to adjust for length.

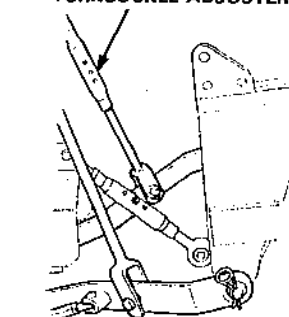

TURNBUCKLE ADJUSTER

- d. Install the UPPER link to the attachment top mast.
- e. Adjust length of the UPPER link with the handle and secure with the lock nut.

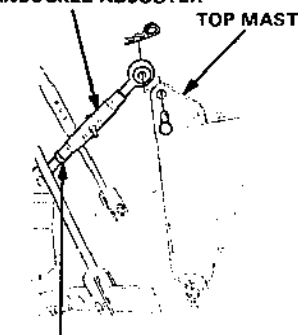

LOCK NUT

f. Install the universal shaft. (P.T.O. driven attachments)

- With the lock on the tractor side fully depressed, insert the universal shaft fully into the P.T.O. hole.
- Release the lock, pull out the joint slowly until the lock returns to the position shown in the diagram.
- Move the universal shaft back and forth and check that the lock is secure.

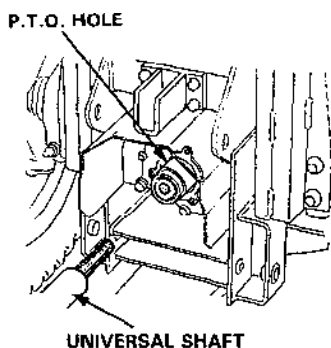

g. Use the turnbuckle adjuster on the right side of the lift rod to get the attachment horizontal. After adjusting, secure with a lock nut.

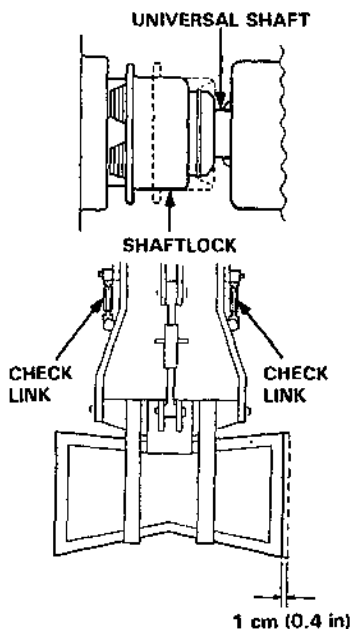
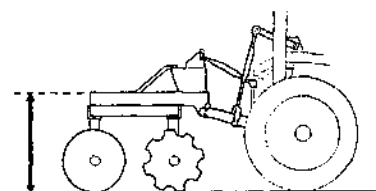

**NOTICE**

- After installing the attachment, check that the lock pins are securely in place.
- If there is noise from the universal shaft while driving, adjust the length of the top link slightly. If there is excessive noise from the universal shaft when in use, damage can be caused to P.T.O. section.
- If the check link is adjusted too tightly, it may break.
- Use only attachment designed for use with this tractor.

## 9. MAINTENANCE

---

### The Importance of Maintenance

Good maintenance is essential for safe, economical, and trouble-free operation. It will also help reduce air pollution.

**▲ WARNING**

**Improper maintenance, or failure to correct a problem before operation, can cause a malfunction in which you can be seriously hurt or killed.**

**Always follow the inspection and maintenance recommendations and schedules in this owner's manual.**

To help you properly care for your tractor, the following pages include a maintenance schedule, routine inspection procedures, and simple maintenance procedures using basic hand tools. Other service tasks that are more difficult, or require special tools, are best handled by professionals and are normally performed by a Honda technician or other qualified mechanic.

The maintenance schedule applies to normal operating conditions. If you operate your tractor under severe conditions, such as sustained high-load or high-temperature operation, or use in unusually wet or dusty conditions, consult your servicing dealer for recommendations applicable to your individual needs and use.

**Maintenance, replacement, or repair of the emission control devices and systems may be performed by any engine repair establishment or individual, using parts that are "certified" to EPA standards.**

---

## Maintenance Safety

Some of the most important safety precautions follow. However, we cannot warn you of every conceivable hazard that can arise in performing maintenance. Only you can decide whether or not you should perform a given task.

### WARNING

**Failure to properly follow maintenance instructions and precautions can cause you to be seriously hurt or killed.**

**Always follow the procedures and precautions in the owner's manual.**

### Safety precautions

- Make sure the engine is off before you begin any maintenance or repairs. This will eliminate several potential hazards:
  - **Carbon monoxide poisoning from engine exhaust.**  
Be sure there is adequate ventilation whenever you operate the engine.
  - **Burns from hot parts.**  
Let the engine and exhaust system cool before touching.
  - **Injury from moving parts.**  
Do not run the engine unless instructed to do so.
- Read the instructions before you begin, and make sure you have the tools and skills required.
- To reduce the possibility of fire or explosion, be careful when working around gasoline. Use only a nonflammable solvent, not gasoline, to clean parts. Keep cigarettes, sparks, and flames away from all fuel-related parts.

Remember that your servicing dealer knows your tractor best and is fully equipped to maintain and repair it.

To ensure the best quality and reliability, use only new, genuine Honda parts or their equivalents for repair or replacement.

---

## **Emission Control System**

### **Source of Emissions**

The combustion process produces carbon monoxide, oxides of nitrogen, and hydrocarbons. Control of hydrocarbons and oxides of nitrogen is very important because, under certain conditions, they react to form photochemical smog when subjected to sunlight. Carbon monoxide does not react in the same way, but it is toxic.

Honda utilizes lean carburetor settings and other systems to reduce the emissions of carbon monoxide, oxides of nitrogen, and hydrocarbons.

### **The U.S. and California Clean Air Acts**

EPA and California regulations require all manufacturers to furnish written instructions describing the operation and maintenance of emission control systems.

The following instructions and procedures must be followed in order to keep the emissions from your Honda engine within the emission standards.

### **Tampering and Altering**

Tampering with or altering the emission control system may increase emissions beyond the legal limit. Among those acts that constitute tampering are:

- Removal or alteration of any part of the intake, fuel, or exhaust systems.
- Altering or defeating the governor linkage or speed-adjusting mechanism to cause the engine to operate outside its design parameters.



---

## **Problems That May Affect Emissions**

If you are aware of any of the following symptoms, have your engine inspected and repaired by your servicing dealer.

- *Hard starting or stalling after starting.*
- *Rough idle.*
- *Misfiring or backfiring under load.*
- *Afterburning (backfiring).*
- *Black exhaust smoke or high fuel consumption.*

---

## **Replacement Partss**

The emission control systems on your Honda engine were designed, built, and certified to conform with EPA and California emission regulations. We recommend the use of genuine Honda parts whenever you have maintenance done. These original-design replacement parts are manufactured to the same standards as the original parts, so you can be confident of their performance. The use of replacement parts that are not of the original design and quality may impair the effectiveness of your emission control system.

A manufacturer of an aftermarket part assumes the responsibility that the part will not adversely affect emission performance. The manufacturer or rebuilder of the part must certify that use of the part will not result in a failure of the engine to comply with emission regulations.

## **Maintenance**

Follow the maintenance schedule on page 82. Remember that this schedule is based on the assumption that your machine will be used for its designed purpose. Sustained high-load or high-temperature operation, or use in unusually wet or dusty conditions, will require more frequent service.

## 1. Tool kit

The tools supplied are necessary for performing some periodic maintenance, simple adjustments and repairs.

The tool kit is stored in the tool box behind the seat.

The tool kit as well as the Owner's Manual should always remain with the tractor.

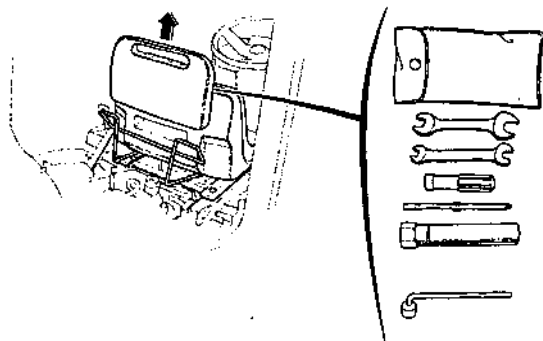

**TOOL BAG**

**14 x 17 mm**

**OPEN END WRENCH**

**10 x 12 mm**

**OPEN END WRENCH**

**SCREWDRIVER GRIP**

**No. 2 SCREWDRIVER**

**SPARK PLUG WRENCH**

**LUG WRENCH**

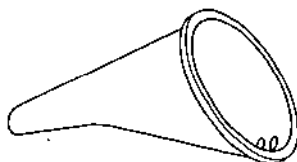

**OIL FUNNEL**

## 2. Maintenance schedule

REGULAR SERVICE PERIOD (3)			EACH USE	FIRST 3MONTHS OR 20 HRS	EVERY 6MONTHS OR 50 HRS	EVERY YEAR OR 100 HRS	EVERY 3YEARS OR 300 HRS	EVERY 5YEARS OR 500 HRS
ITEM	Perform at every indicated month or operating hour interval, whichever comes first.							
• Engine oil	Check level		○					
	Change			○		○		
Hydraulic life system Oil level and oil leakage	Check		○					
	Check		○					
Battery electrolyte	Check level		○					
• Aircleaner	Check		○					
	Clean				○(1)			
	Replace						○(*)	
Radiator screen	Clean				○			
Radiator coolant	Check		○					
	Change	Every 2 years (2)						
Radiator core	Clean					○		
Interlock system operation Seat switch front P.T.O clutch, rear P.T.O clutch, main transmission lever	Check		○					
Parking brake operation	Check		○					
	Readjust						○ (2)	
Tires; bolt tightness Air pressure, cracks, damage, etc.	Check-tighten		○(4)	○	○			
	Check		○					
Steering wheel free play or looseness	Check		○					
Headlight	Check		○					
Front P.T.O belt	Check		○					
Clutch pedal free play	Check		○					
	Readjust						○ (2)	
Brake pedal free play	Check		○					
	Readjust					○ (2)		
Brake wear indicator	Check		○					
Fan belt	Check		○					
	Adjust				○ (2)			
Differential lock pedal free play	Check-Readjust						○ (2)	

REGULAR SERVICE PERIOD (3)		EACH USE	FIRST 3MONTHS OR 20 HRS	EVERY 6MONTHS OR 50 HRS	EVERY YEAR OR 100 HRS	EVERY 3YEARS OR 300 HRS	EVERY 5YEARS OR 500 HRS
ITEM	Perform at every indicated month or operating hour interval, whichever comes first.						
•	Fuel filter	Change	Every 200hrs or Every 2 years				
	Fuel tank	Clean				○ (2)	
	All fasteners (for tightness)	Check-Retighten		○			
	Lubrication points	Oil-Grease		○			
	Transmission oil	Check level			○		
		Change					○ (2)
•	Spark plug	Check-Readjust			○		
		Replace				○	
	Spark arrester (optional part)	Clean			○		
•	Idle speed	Check-Readjust				○ (2)	
•	Engine oil filter	Replace				○ or 200hr	
•	Valve clearance	Check-Readjust				○ (2)	
	Tie-rods (for bending), ball-joints (for looseness) Toe-in	Check-Readjust				○ (2)	
•	Fuel line	Check (Replace if necessary)	Every 2 years (2)				

**NOTE:** • Emission related items.

(\*) Replace the paper element only.

(1) Service more frequently when used in dusty areas.

(2) These items should be serviced by an authorized Honda tractor dealer, unless the owner has the proper tools and is mechanically proficient. See the Honda Shop Manual.

(3) For professional commercial use, log hours of operation to determine proper maintenance intervals.

(4) Check the nuts daily for the first 20 hours of operation, and retighten if necessary.

---

### 3. Engine oil change

Drain the oil while the engine is warm to assure rapid and complete draining.

1. Open the engine hood.
2. Prepare a suitable container and the funnel furnished.
3. Remove the oil filler cap and drain plug and drain oil into the container through the funnel. Be sure not to spill oil onto the frame.
4. Retighten the drain plug securely.
5. Refill to the upper level mark on the dipstick with the recommended oil (see page 29). Tighten the oil filler cap securely.

**OIL CAPACITY: 2.0 l (2.1 US qt)**

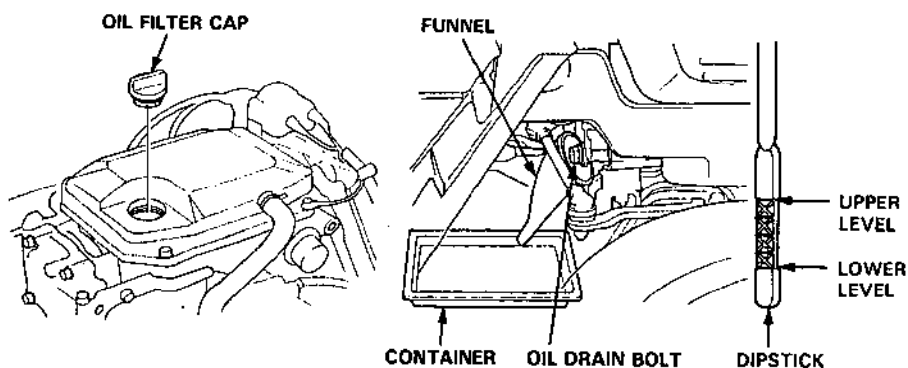

Wash your hands with soap and water after handling used oil.

Please dispose of used motor oil in a manner that is compatible with the environment. We suggest you take it in a sealed container to your local service station or recycling center for reclamation. Do not throw it in the trash, pour it on the ground or down a drain.

---

#### 4. Air cleaner service

A dirty air cleaner will restrict air flow to the carburetor. If you operate the tractor in very dusty areas, clean the air cleaner more often than specified in the MAINTENANCE SCHEDULE.

Operating the engine without the air cleaner will cause rapid engine wear.

1. Open the engine hood.
2. Remove the wing nuts and remove the air cleaner cover. Remove the elements and separate them. Carefully check both elements for holes or tears and replace if damaged.

NOTE: Be sure to remove the foam element from the air cleaner cover so that you can inspect both sides.

3. Foam element: Clean in warm, soapy water, rinse, and dry thoroughly. Or, clean in nonflammable solvent and dry.

Dip the element in clean engine oil, then squeeze out all excess oil. The engine will smoke when started if too much oil is left in the foam.

**▲ WARNING** Using gasoline or flammable solvent to clean the filter element can cause a fire or explosion. Use only soapy water or nonflammable solvent.

4. Paper element: Tap the element several times on a hard surface to remove loose dirt, or blow low pressure (30 psi or less) compressed air through the filter from the inside. Do not try to brush off dirt. Brushing will force dirt into the fibers.

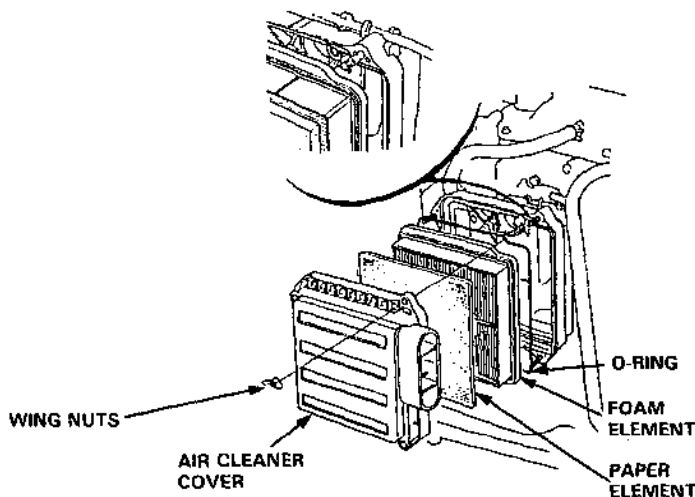

---

## 5. Spark plug service

**Recommended spark plug: BPR5ES-11 (NGK)  
W16EPR-U11 (DENSO)**

**⚠ WARNING** Touching a hot engine or exhaust system can cause serious burns. Let the engine cool before performing maintenance.

**NOTICE** Spark plugs of the wrong heat range can cause engine damage.

For good performance, the spark plug must be properly gapped and free of deposits.

1. Open the engine hood and remove the spark plug caps.
2. Clean any dirt from around the spark plug bases.
3. Use a spark plug wrench to remove the spark plugs.

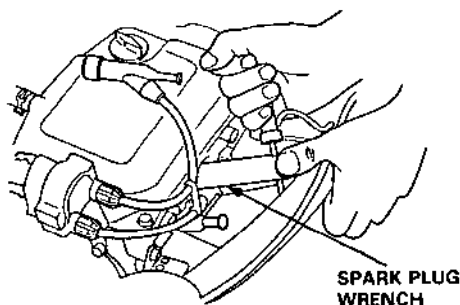

4. Visually inspect the spark plugs. Discard the spark plugs if there is apparent wear, or if the insulators are cracked or chipped. Clean the spark plugs with a wire brush if they are to be reused.
5. Measure the plug gaps with a feeler gauge. The gaps should be 1.0–1.1 mm (0.039–0.043 in). Correct as necessary by carefully bending the side electrode.

1.0–1.1 mm  
(0.039–0.043 in)

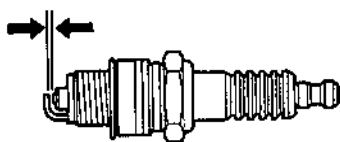



- 
6. Install the spark plug carefully, by hand, to avoid cross-threading.

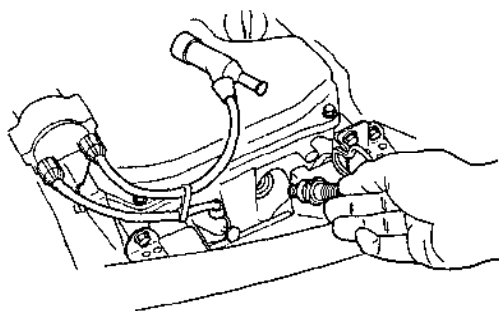

7. After the spark plug is seated, tighten with a spark plug wrench to compress the washer.

**NOTICE** Loose spark plug can get hot enough to damage the engine. Overtightening may damage the threads.

**NOTE:** If installing a new spark plug, tighten  $1/2$  turn after the spark plug seats to compress the washer. If reinstalling a used spark plug, tighten  $1/8$ – $1/4$  turn after the spark plug seats to compress the washer.

---

## 6. Battery service

### ■ Refilling battery fluid

If the tractor is operated with insufficient battery electrolyte, sulfation and battery plate damage will occur.

If rapid loss of electrolyte is experienced, or if your battery seems to be weak, causing slow starting or other electrical problems, see your authorized Honda tractor dealer.

Open the engine hood and check the electrolyte level in each battery cell. Fill the battery with distilled water to the upper level line. Never overfill the battery.

**⚠ WARNING** Batteries produce explosive gases: If ignited, an explosion can cause serious injury or blindness. Provide adequate ventilation when charging.

• **CHEMICAL HAZARD:** Battery electrolyte contains sulfuric acid. Contact with eyes or skin, even through clothing, may cause severe burns. Wear a faceshield and protective clothing.

• Keep flames and sparks away, and do not smoke in the area.

**ANTIDOTE:** If electrolyte gets into your eyes, flush thoroughly with warm water for at least 15 minutes and call a physician immediately.

• **POISON:** Electrolyte is poison.

**ANTIDOTE**

– External: Flush thoroughly with water.

– Internal: Drink large quantities of water or milk.

Follow with milk of magnesia or vegetable oil, and call a physician immediately.

• **KEEP OUT OF REACH OF CHILDREN.**

**NOTE:** Use distilled water in the battery.

• Tap water will shorten the service life of the battery.

• Overfilling may cause electrolyte overflow and corrosion. Wash off any spilled electrolyte immediately.

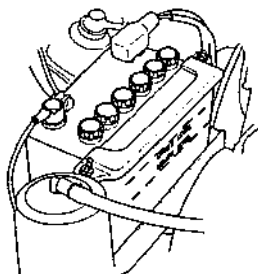

UPPER LEVEL  
LOWER LEVEL

## ■ Battery cleaning

If the battery terminals are contaminated or corroded, remove the battery and clean the terminals.

1. Remove battery battery hold down.
2. Disconnect the battery cable at the battery negative (-) terminal, then at the battery positive (+) terminal.

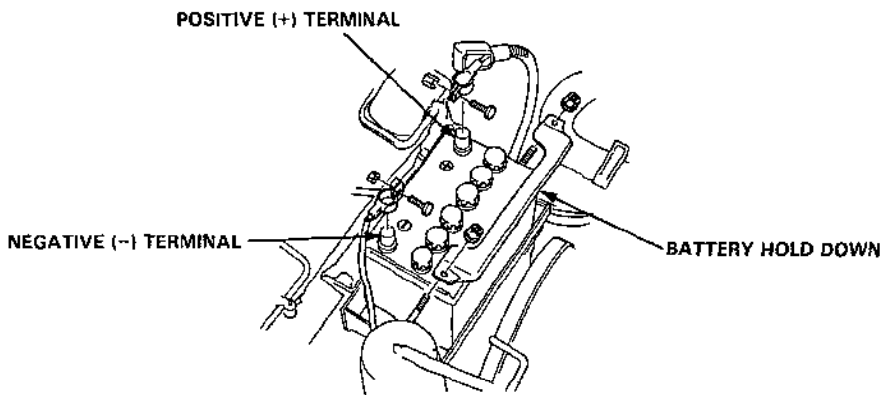

3. Remove the battery and clean the battery terminals and battery cable terminals with a wire brush or sand paper. Clean the battery with a solution of baking soda and warm water, taking care not to get the solution or water in the battery cells. Dry the battery thoroughly.
4. Connect the battery positive (+) cable to the battery positive (+) terminal, then the battery negative (-) cable to the battery negative (-) terminal. Tighten the bolts and nuts securely.
5. Coat the battery terminals with grease.
6. Reinstall the battery battery hold down.

**▲ CAUTION** When disconnecting the battery cable, be sure to disconnect at the battery negative (-) terminals first. To connect, connect at the positive (+) terminal first, then at the negative (-) terminal. Never dis/connect the battery cable in the reverse order, or it causes a short circuit when a tool contacts the terminals.

## 7. Fuel filter change

### ⚠ WARNING

- Gasoline is extremely flammable and explosive under certain conditions. Do not smoke or allow flames or sparks in the area.

Remove the fuel filter by pulling it out of its clip behind the fuel tank and visually inspect it.

Replace the filter if it is contaminated with dirt or water.

Set the fuel filter in the clip with the flanged end facing the front.

After installing a new fuel filter, turn the steering wheel extreme right to make sure that the fuel hose and clip are not interfering with the adjacent or surrounding parts.

NOTE: Drain the gas tank before disconnecting the fuel lines from the fuel filter. See page 99.

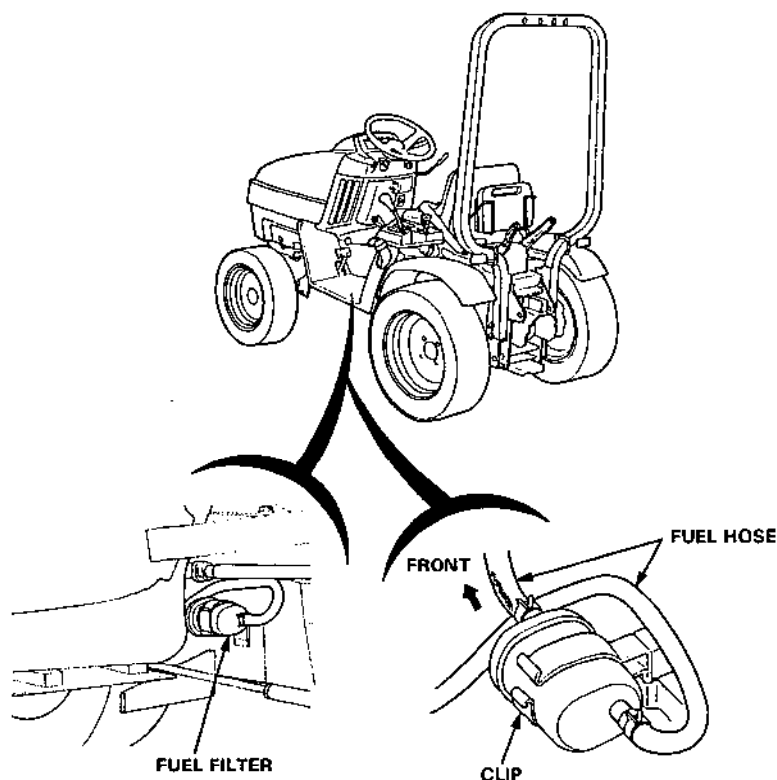

## 8. Radiator Screen/Radiator Core Servicing

Remove any debris from radiator screen and core.

To remove:

1. Remove the right and left knob bolts.
2. Raise the both ends of the column cover and slide the pin to the bottom of the slot. Then remove the cover by pulling it toward you.
3. Release the lock by pulling the top of the screen toward you.
4. Remove the screen by pulling it up ward. Remove any debris from the radiator screen and radiator core.

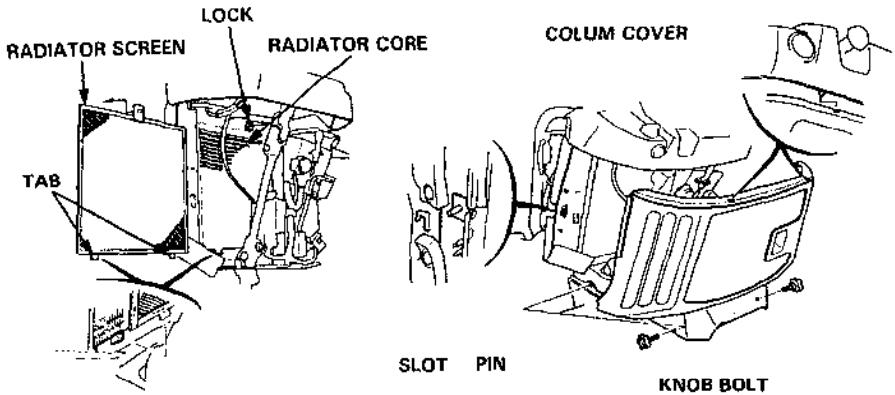

To install:

1. Install the radiator screen by sliding the tab on the bottom of the screen into the groove of the radiator.
2. Lock the screen by pushing in on the top of the screen.
3. Slightly lift the column cover both ends, then slide the pin back to the upper end of the slot. Align the tab on the column with the groove in the column cover and slightly raise the column cover.
4. Install the knob bolts.

---

## 9. Transmission oil inspection

**NOTICE** Contaminated or insufficient oil will reduce the service life of the tractor's transmission. Follow the instructions for maintenance interval and oil capacity.

1. Park the tractor on level ground.
2. Remove the oil check bolt from the transmission rear cover.
3. The oil level should be at the lower edge of the check bolt hole; if it is not, add oil through the check bolt hole until the level reaches the lower edge.
4. After checking, tighten the oil check bolt securely.  
Recommended oil: 10W-30

**NOTE:** If the outside temperature is below  $-15^{\circ}\text{C}$ , use SAE 5W-30 engine oil. Consult your authorized Honda tractor dealer if replacement of the transmission oil is necessary.

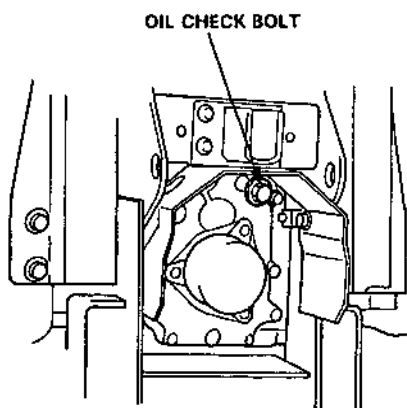

## 10. All fasteners tightness/lubrication points

- Check all nuts, bolts and fasteners and tighten securely if necessary.
- Check and apply grease where noted.

Recommended Grease: SAE Multipurpose Grease

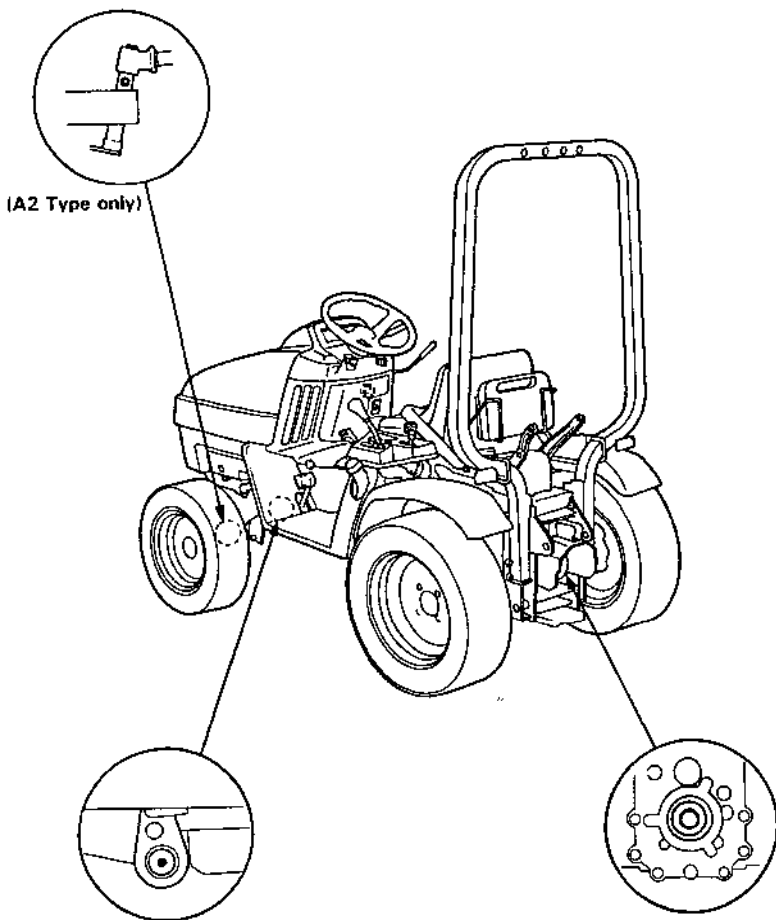

---

## Lubrication points (cont'd)

Check and apply grease where noted.  
Recommended grease: SAE Multipurpose Grease.

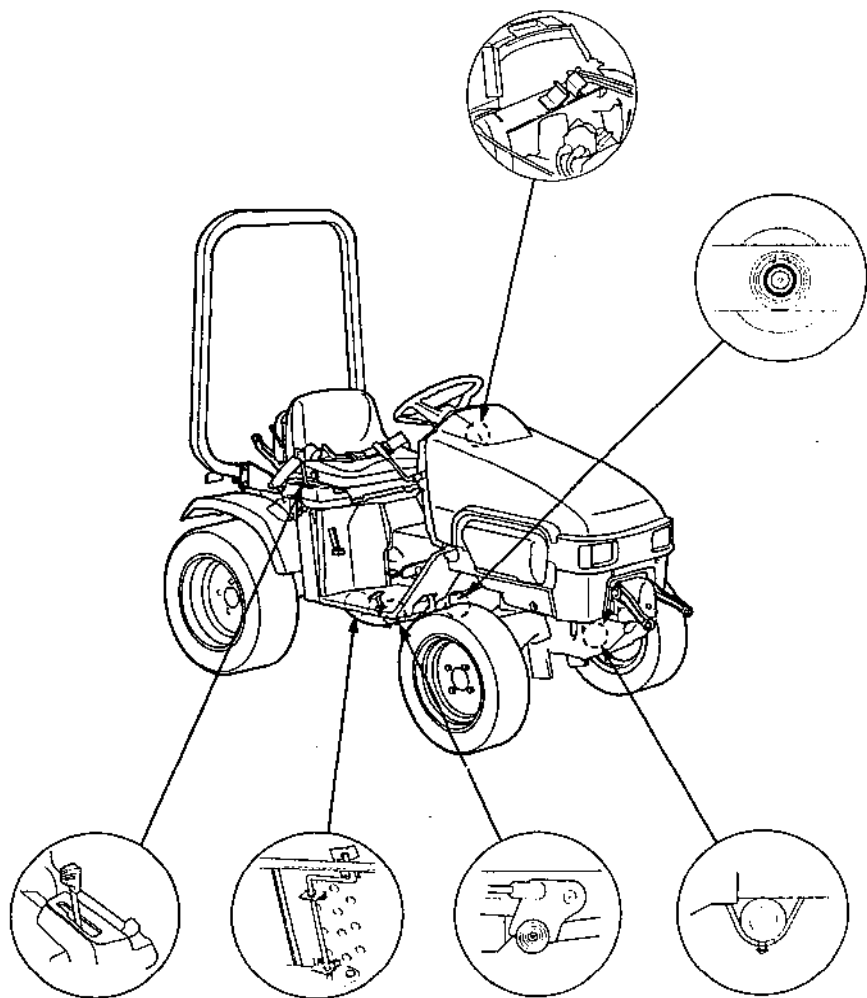



---

## 11. Spark arrester maintenance (optional part)

You can purchase an optional, U.S.D.A. qualified spark arrester from your authorized Honda tractor dealer. Spark arresters are required in some areas; check local laws and regulations before operating your tractor.

**▲ WARNING** The muffler becomes very hot during operation and remains hot for a while after the engine stops. Be careful not to touch the muffler while it is hot. Allow it to cool before proceeding.

The spark arrester must be serviced every 100 hours to maintain its efficiency.

1. Remove the four 6 mm bolts and remove the muffler protector.
2. Remove the two 5 mm screws from the exhaust pipe tip. Remove the exhaust pipe tip and spark arrester (be careful not to damage the spark arrester screen).
3. Use a wire brush to remove carbon deposits from the spark arrester screen.

**NOTE:** Inspect the spark arrester screen for holes or tears. Replace it if it is damaged.

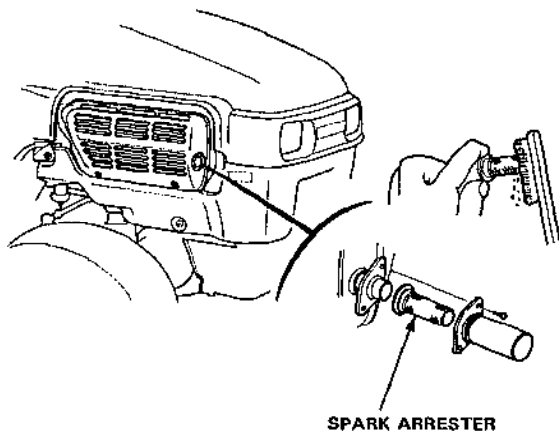

---

## 12. Wheel removal

Do not attempt to remove a wheel unless the tractor is on firm level ground.

Do not attempt to remove or replace a tire unless you have the equipment and knowledge to do so properly.

1. Apply the parking brake and put the transmission in gear.
2. Block the wheels securely and loosen the lug nuts counterclockwise one turn.
3. Place a jack under the jack point nearest the wheel you are removing and raise the wheel off the ground.
4. Remove the nuts and wheel.
5. Install the wheel and hand-tighten reinstall the nuts.
6. Lower the tractor, remove the jack, and then tighten the nuts a little at a time in an "X" pattern.

**Specified torque: 13 kg-m (94 ft-lb)**

### [JACK POINTS]

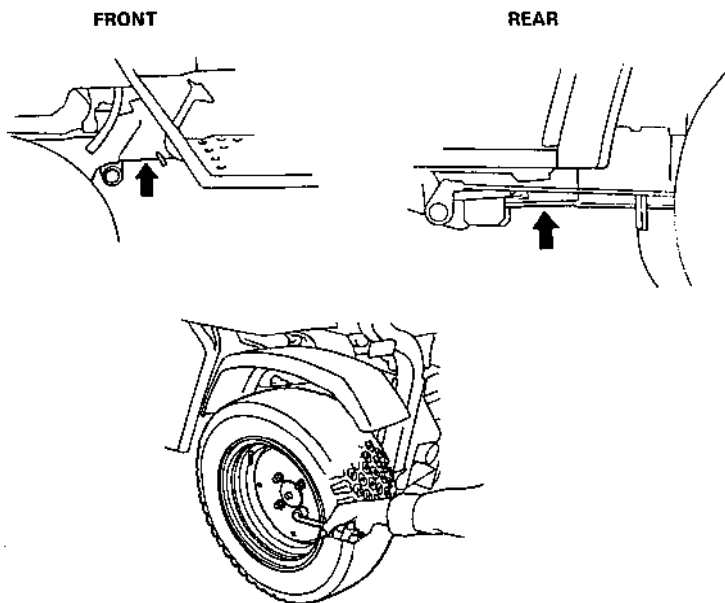

---

### 13. Fuse replacement

The fuse box is located near the battery.

When frequent fuse failure occurs, it usually indicates a short circuit or an overload in the electrical system. See your authorized Honda tractor dealer for repair.

To replace fuses pull the old fuse out of the clips with your finger. Push a new fuse into the clips.

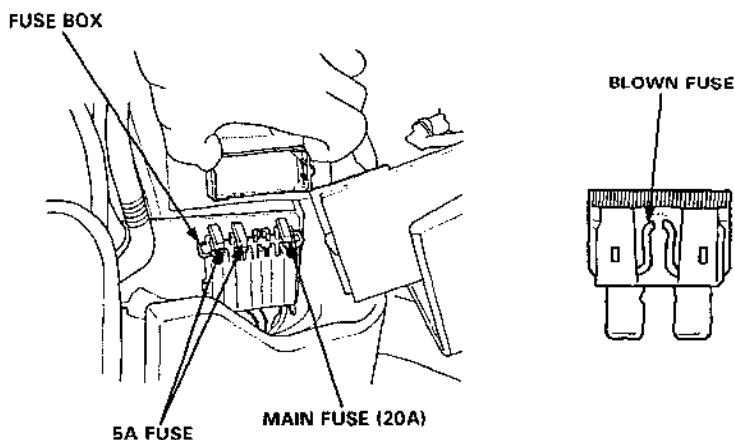

**NOTICE** Never use fuse with a different rating from that specified. Serious damage to the electrical system or a fire may result.

Turn the engine switch (ignition switch) OFF and remove the key before checking or replacing fuses to prevent accidental short-circuiting.

---

## 14. Headlight bulb replacement

Open the engine hood and lift up the edge of the bulb connector rubber cover and pull it back.

Push in and turn the bulb connector counterclockwise, then remove the connector and bulb.

Install the bulb, and then align the tab on the bulb connector with the cutout in the headlight case. Turn the bulb connector clockwise while pushing it in, and then fit the rubber cover down over the connector.

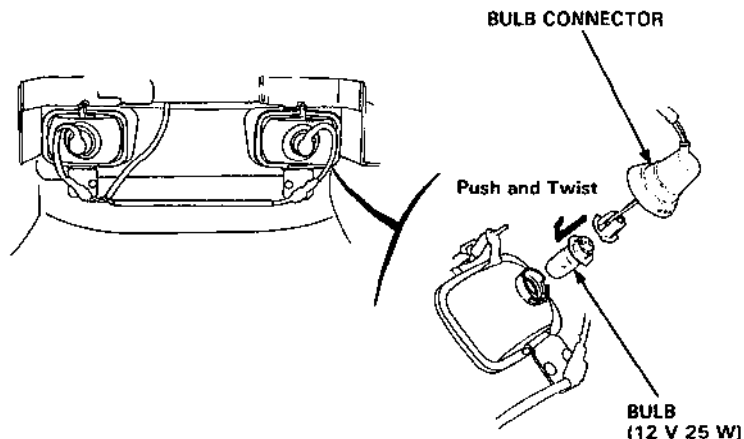

## 10. LONG TERM STORAGE

### Preparation for storage

The engine becomes very hot during operation and remains hot for a while after stopping. Allow the engine to cool before storing.

**▲WARNING** Contact with a hot engine or exhaust system can cause serious burns or fires. Let the engine cool before storing.

The following steps should be taken to protect the lawn tractor whenever it will be stored for longer than 30 days.

1. Pump all gasoline from the fuel tank into an approved gasoline container.

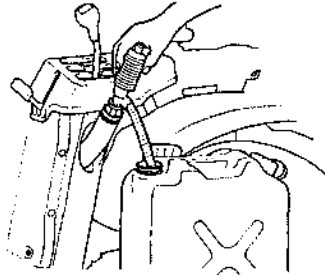

Loosen the carburetor drain screw, and drain the fuel into an approved gasoline container. After draining, tighten the drain screw securely.

**▲WARNING** Gasoline is extremely flammable, and gasoline vapor can explode, causing serious injury or death. Use extreme care when handling gasoline.

Keep flames and sparks away, and do not smoke in the area.

**NOTE:** If gasoline is not drained before storage, fuel system damage may result.

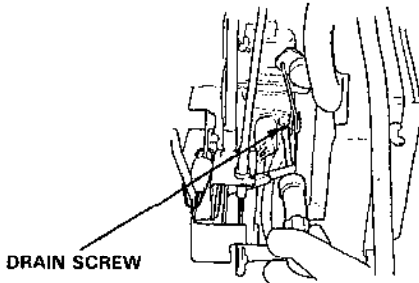

---

2. Change the engine oil (see page 84).

**NOTE:** If the tractor will be stored for longer than 3 months, open the engine hood, remove the spark plugs and pour three tablespoons (approximately 1 oz.) of clean motor oil into the cylinders.

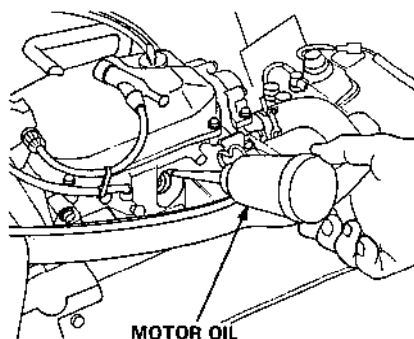

Turn the fan belt several rotations by hand.  
Reinstall the spark plugs.

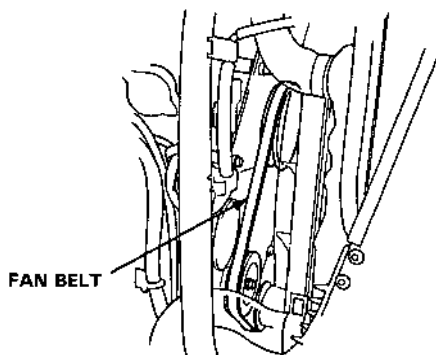

**CAUTION** Be sure to wear heavy-duty gloves when turning fan belt. If the tractor has been running, the engine will be very hot. Allow it to cool before proceeding.

3. Remove the battery and store in a cool, dry place. Recharge it once a month.

- 
4. Store the tractor on a level surface in a dry, dust-free area with the parking brake lever set.
  5. Cover the tractor to keep out dust.
  6. Check tire air pressure regularly during storage and inflate if necessary.

#### **Removal from storage**

1. Check the battery electrolyte level (see p. 88). Fully recharge the battery, and install it in the tractor.
2. Remove the spark plugs and check that they are clean and properly gapped (see p. 86). Turn the engine a few revolutions with the starter motor before reinstalling the spark plugs.
3. Thread the spark plugs in as far as possible by hand, then tighten them 1/8 to 1/4 turn further with the plug wrench.
4. Check the engine oil level (see p. 29).
5. Check the coolant level (see p. 34).
6. Fill the fuel tank, and start the engine by following the starting instructions (see p. 47).

**NOTE:** If the cylinders were coated with oil, the engine will initially smoke at start up; this is normal.

# 11. WIRING DIAGRAM

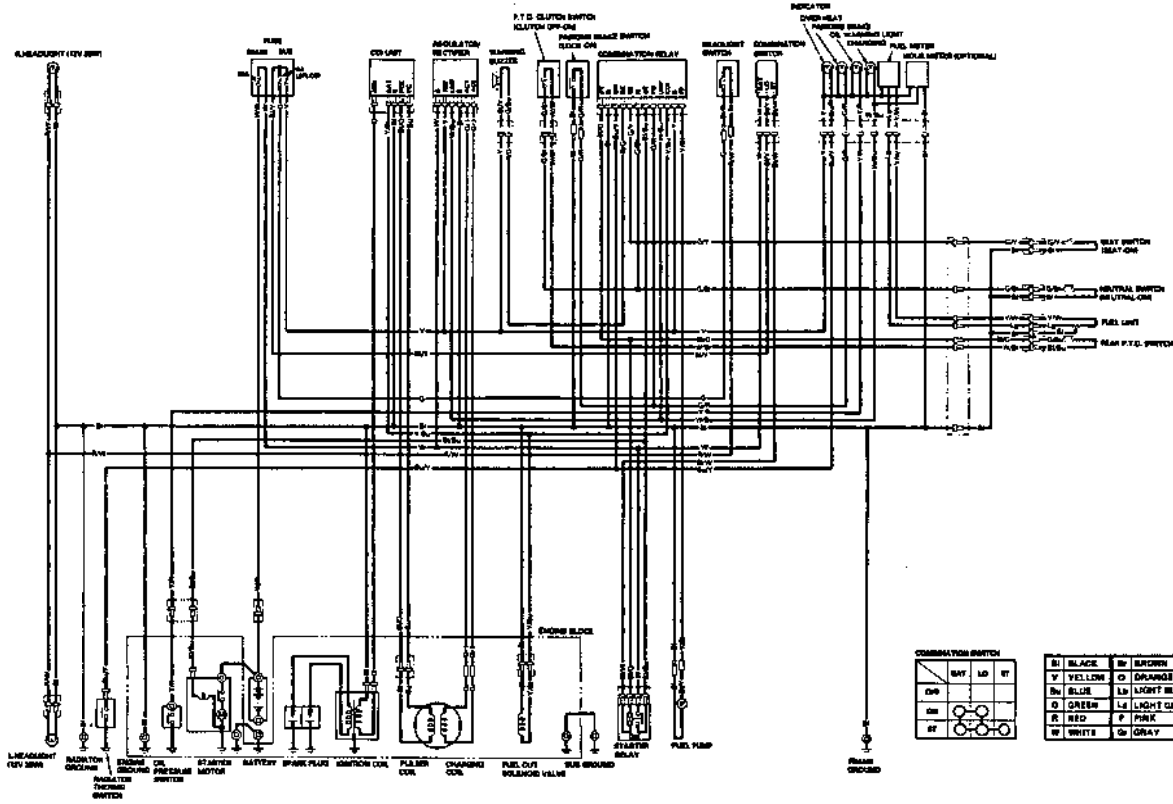



## 12. TROUBLESHOOTING

### STARTER

- Starter does not work;
  1. Main transmission shift lever set in —————> Shift lever in "N" other than NEUTRAL.
  2. Front or rear PTO clutch lever set in —————> Set lever in "OFF" ON.
  3. Loose or corroded battery terminal —————> Retighten or clean (see p. 89)
  4. Blown fuse —————> Replace (see p. 97)
  5. Battery discharged —————> See your authorized Honda tractor dealer

### ENGINE

- Engine cranks but won't start;
  1. No fuel in tank —————> Refill tank (see p. 30)
  2. Choke not pulled out when engine is cold —————> Pull out choke
  3. Disconnected spark plug cap —————> Reinstall cap
  4. Faulty plug —————> Clean or replace (see p. 86)
  5. Blown fuse —————> Replace (see p. 97)
  6. Faulty fuel cut solenoid valve —————> See your authorized Honda tractor dealer
- Engine lacks power;
- Unstable engine rpm;
- Stalling after starting;
- Overheating;
  1. Improper grade of fuel —————> Drain residual fuel and refill (see p. 31)
  2. Front PTO clutch out of adjustment (not disengaged completely) —————> See your authorized Honda tractor dealer
  3. Throttle cable not adjusted properly —————> See your authorized Honda tractor dealer
  4. Governor not adjusted properly —————> See your authorized Honda tractor dealer
  5. Carburetor faulty —————> See your authorized Honda tractor dealer
  6. Ignition system faulty —————> See your authorized Honda tractor dealer
  7. Fuel filter clogged —————> See your authorized Honda tractor dealer
  8. Air cleaner clogged —————> Clean (see p. 85)
  9. Faulty spark plug —————> Clean or replace (see p.86)
  10. Improper governor operation —————> See your authorized Honda tractor dealer

- 11. Incorrect valve clearance → See your authorized Honda dealer
  - 12. Improper grade of fuel → Drain residual fuel and refill (see p. 31)
  - 13. Improper attachment → Replace with recommended attachment
  - 14. Extreme weather/barometric conditions (altitude, temperature) → See your authorized Honda tractor dealer
  - 15. Parking brake not released fully → Release fully
  - 16. Brake dragging → See your authorized Honda tractor dealer
  - 17. Excessive load → Reduce load or speed
  - 18. Clogged radiator screen → Clean (see p. 91)
  - 19. Lack of radiator coolant → Fill with recommended coolant (see p. 34)
- Excessive oil consumption
    - 1. Improper oil viscosity → Use correct viscosity of oil (see p. 29)
    - 2. Oil leak → Check drain plug for tightness
    - 3. Worn piston ring/cylinder → See your authorized Honda tractor dealer

### ELECTRICAL SYSTEM

- Battery runs down frequently
  - 1. Loose or corroded battery terminal → Clean or retighten (see p. 89)
  - 2. Low electrolyte level → Add distilled water (see p. 88)
  - 3. Damaged battery cell → Replace battery
  - 4. Faulty battery charging coil → See your authorized Honda tractor dealer
- Oil pressure warning lamp remains "ON" after engine is started
  - 1. Lack of oil in engine oil pan → Replenish oil
  - 2. Faulty oil alert → See your authorized Honda tractor dealer
- Oil pressure warning lamp not turned "ON" immediately after engine starts
  - 1. Blown lamp bulb → See your authorized Honda tractor dealer
  - 2. Blown fuse → Replace (see p. 97)

- 
- 3. Faulty oil alert → See your authorized Honda tractor dealer
  
  - Headlights not turned ON
    - 1. Blown light bulb → Replace (see p. 98)
    - 2. Ignition key not turned to ON → Turn ignition key to ON
    - 3. Blown fuse → Replace (see p. 97)
  
  - Parking brake audible alert buzzer not operated
    - 1. Blown fuse → Replace (see p. 97)
    - 2. Faulty buzzer → See your authorized Honda tractor dealer
  
  - Fuel gauge inoperative
    - 1. Blown fuse → Replace (see p. 97)
    - 2. Faulty gauge → See your authorized Honda tractor dealer

## **BRAKES**

- Poor brake performance
  - 1. Clutch pedal not depressed → Apply brake while depressing clutch pedal
  - 2. Excessive brake pedal play → See your authorized Honda tractor dealer
  - 3. Brake linings worn → See your authorized Honda tractor dealer
  - 4. Excessive inertia/weight of attachment → Use correct attachment in correct manner
  
- Brake applied only on one side
  - 1. Incorrect brake adjustment → See your authorized Honda tractor dealer
  - 2. Brake pedal shaft sticking → Apply grease
  - 3. Uneven tire pressure → Inflate tires to correct pressure (see p. 39)

## **CLUTCH**

- Clutch not disengaged, Clutch not engaged
  - 1. Improper clutch adjustment → See your authorized Honda tractor dealer
  - 2. Clutch discs worn → See your authorized Honda tractor dealer

## STEERING

- Hard steering
  1. Insufficient tire pressure → Inflate tires to correct tire pressure (see p. 39)
  2. Differential lock applied → Release lock
  3. Excessive weight of attachment → Follow attachment weight recommendation (see p. 56)
  4. Uneven weight distribution → Adjust with counterweights (see p. 60)
  5. Attachments towed too heavy → Follow weight limit recommendations (see p. 58)
- Steers to one side or does not track straight
  1. Incorrect brake adjustment → See your authorized Honda tractor dealer
  2. Incorrect front-end alignment → See your authorized Honda tractor dealer
  3. Uneven tire pressures → Inflate tires to correct pressure (see p. 39)
  4. Loose fasteners in steering linkage → See your authorized Honda tractor dealer
  5. Loose wheel nuts → Retighten to specified torque (see p. 39)

## DIFFERENTIAL LOCK

- Differential lock not applied
  1. Improper pedal play → See your authorized Honda tractor dealer
  2. Power not transmitted to wheels → Shift into LOW speed, engage clutch, and then depress pedal
- Differential lock not released
  1. Load from wheels applied to differential lock → Drive in opposite direction a little to release load from differential lock

## FRONT P.T.O.

- PTO does not rotate (or rotates too slowly)
  1. Primary belt broken → See your authorized Honda tractor dealer
  2. Insufficient primary belt tension → See your authorized Honda tractor dealer
  3. Incorrect clutch lever free play → See your authorized Honda tractor dealer
  4. P.T.O. cable broken → See your authorized Honda tractor dealer

- PTO not stopped
  1. Cable out of adjustment → See your authorized Honda dealer
  2. PTO brake rod out of adjustment → See your authorized Honda dealer
  3. PTO brake spring damaged or out of adjustment → See your authorized Honda dealer

### REAR P.T.O.

- PTO does not rotate
  1. PTO lever not set in ON → Set lever in ON
- PTO drive shaft cannot be installed
  1. Foreign matter on shaft splines → Clean and apply grease (see p. 93)
  2. Shaft not inserted into PTO sufficiently → Insert fully (see p. 75)
- PTO lever will not shift to ON (gear noise heard)
  1. Clutch pedal not depressed → Depress clutch pedal before shifting
  2. Attachment still coasting due to inertia → Bring attachment to complete stop before shifting

### HYDRAULIC LIFT

- Lift arm does not raise (or raises slowly)
  1. Change lever not shifted into FRONT or REAR fully → Set in FRONT or REAR securely
  2. Insufficient fluid in system → Replenish (see p. 40)
  3. Loss of fluid → See your authorized Honda tractor dealer
  4. Descending speed adjusting knob closed → Adjust speed (see p. 27)
  5. Load on lift arm exceeding limits → Follow load limit recommendations (see p. 56)
  6. Faulty hydraulic valve or pump → See your authorized Honda tractor dealer
- Lift arm lowered by its own weight
  1. Lack of fluid in system → Replenish (see p. 40)
  2. Lift lever not set in NEUTRAL → Set lever in NEUTRAL
  3. Loss of fluid → See your authorized Honda tractor dealer
  4. Faulty hydraulic control valve → See your authorized Honda tractor dealer

## 13. SPECIFICATIONS

MODEL	H5518
Power product description code	Honda TZAC
<b>DIMENSION</b>	
Overall length	2,190 mm (86.2 in)
Overall width	1,060 mm (41.7 in)
Overall height	1,800 mm (70.9 in) with R.O.P.S
Ground clearance	170 mm (6.7 in)
Wheelbase	1,305 mm (51.4 in)
Wheel tread (Front)	855 mm (33.7 in)
(Rear)	850 mm (33.5 in)
Dry weight	A4 type: 460 kg (1,014 lbs) A2 type: 430 kg (948 lbs)
<b>ENGINE</b>	
Model	GX640
Type	4-stroke, OHC, 2 cylinder
Cooling system	Liquid cooled
Displacement	635 cm <sup>3</sup> (38.7 cu in)
Bore and stroke	76 x 70 mm (3.0 x 2.8 in)
Maximum horsepower	18 ps/3000 r.p.m.
Oil capacity	2.0 ℓ (2.1 U.S. qt)
Coolant capacity	2.7 ℓ (2.9 US qt)
<b>FRAME</b>	
Brakes	Mechanical leading-trailing shoe type brake (rear wheels)
Front tire size, pressure	20 x 7.00-12 (2 PR), 1.0 kg/cm <sup>2</sup> (14.2 psi)
Rear tire size, pressure	24 x 8.00-14 (2 PR), 0.8 kg/cm <sup>2</sup> (11.4 psi)
Steering	Pinion-and-sector four-wheel steering
Fuel tank capacity	9.3 ℓ (2.5 U.S. gall)
<b>DRIVE TRAIN</b>	
Transmission type	Selective sliding 8 speeds forward and 4 speeds reverse transmission
Travel speeds (at full 2,950 r.p.m.)	
Forward	
1 (L-1)	0.7 km/h (0.4 mile)
2 (H-1)	1.1 km/h (0.7 mile)
3 (L-2)	1.5 km/h (0.9 mile)
4 (H-2)	2.4 km/h (1.5 mile)
5 (L-3)	3.4 km/h (2.1 mile)
6 (H-3)	5.3 km/h (3.3 mile)
7 (L-4)	7.1 km/h (4.4 mile)
8 (H-4)	11.1 km/h (6.9 mile)

\* A4 type: Two and Four-Wheel Drive  
A2 type: Two-Wheel Drive only

Reverse	1 (L-R1) 2 (H-R1) 3 (L-R2) 4 (H-R2)	0.8 km/h (0.5 mile) 1.4 km/h (0.7 mile) 1.8 km/h (1.1 mile) 2.8 km/h (1.7 mile)
Transmission oil capacity		3.8 l (4.0 U.S. qt)
Front differential oil capacity		0.45 l (0.48 U.S. qt)
Final reduction oil capacity		0.2 l (0.21 U.S. qt)
<b>HYDRAULIC SYSTEM</b>		
Working pressure		90 kg/cm <sup>2</sup> (1,280 psi)
Pump type		Gear pump
Oil Capacity		1.8 l (1.9 U.S. qt)
<b>P.T.O.</b>		
Type	Rear Front	Dependent of main clutch Live independent
Shaft	Rear	ASAE "O" Category INV. spline 1 inch 15 teeth (female)
	Front	INV. spline 1 inch 15 teeth (male)
Speed	Rear Front	2,045 rpm at engine speed of 2,950 r.p.m. 2,950 rpm at engine speed of 2,950 r.p.m.
<b>ELECTRICAL</b>		
Battery		12V-30AH
Spark plug		BPR5ES-11 (NGK), W16EPR-U11 (DENSO)
Ignition system		C.D.I.

## **14. WARRANTY SERVICE INFORMATION**

---

Honda power equipment dealership personnel are trained professionals. They should be able to answer any question you may have. If you encounter a problem that your dealer does not solve to your satisfaction, please discuss it with the dealership's management. The Service Manager or General Manager can help. Almost all problems are solved in this way.

If you are dissatisfied with the decision made by the dealership's management, contact the Honda Power Equipment Customer Relations Office. You can write to:

American Honda Motor Co., Inc.  
Power Equipment Division  
Customer Relations Office  
4475 River Green Parkway  
Duluth, Georgia 30136-2565

Or telephone: (770) 497-6400

When you write or call, please give us this information:

- Model and serial number (see page 10)
- Name of dealer who sold the tractor to you
- Name and address of dealer who services your tractor
- Date of purchase
- Your name, address, and telephone number
- A detailed description of the problem



---

MEMO

---

MEMO

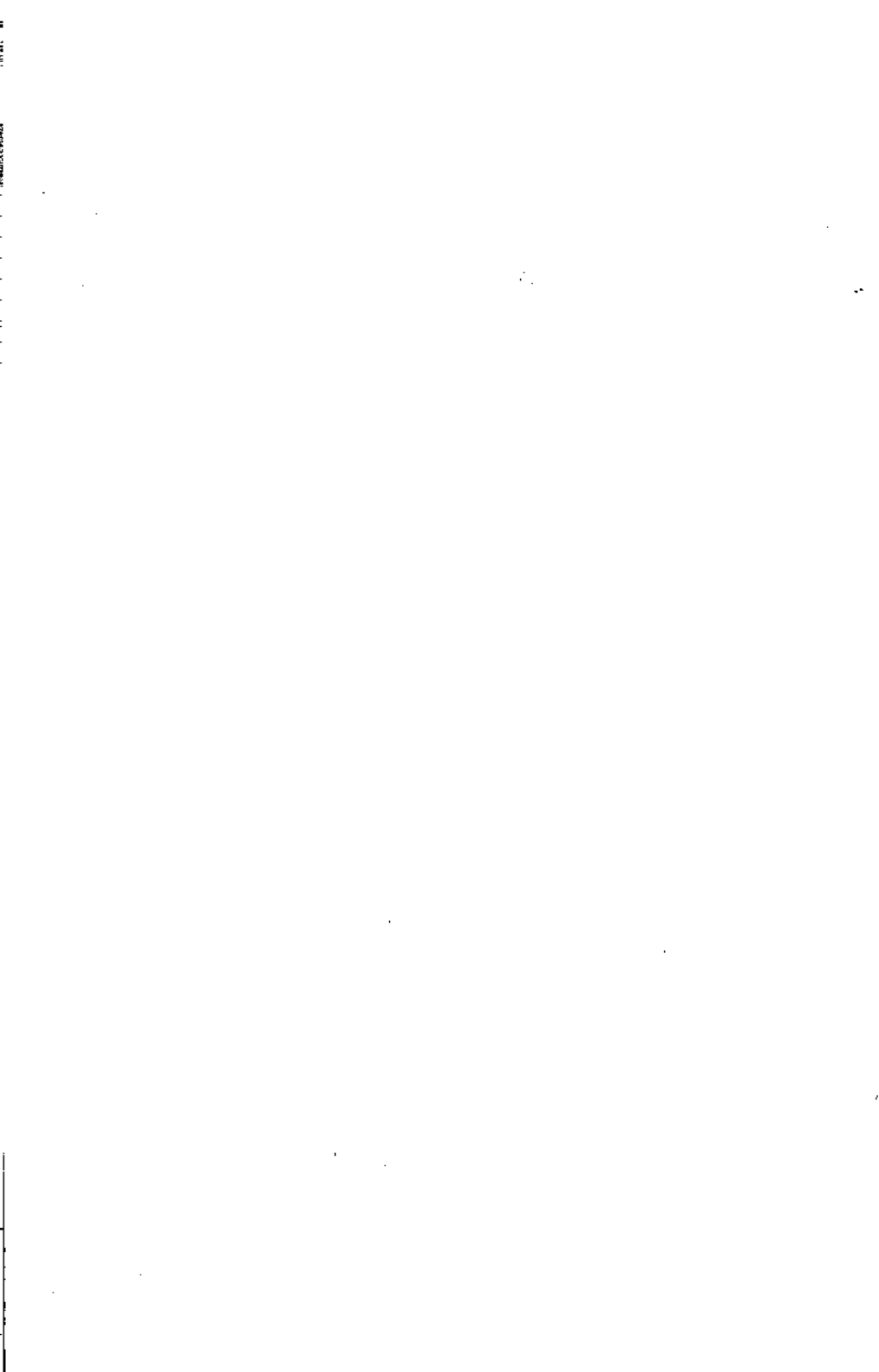

**HONDA**

P/N 31769611  
00X31-769-6110



Printed on  
Recycled Paper

POM52083

10.2001.12

PRINTED IN U.S.A.