

HONDA

Power

Equipment

Owner's Manual

LAWN TRACTOR

H4013

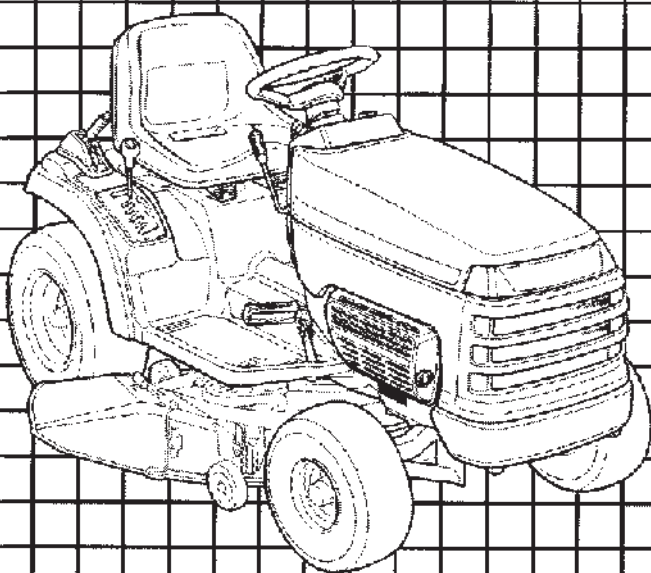

Thank you for purchasing a Honda lawn tractor.

This manual describes operation and maintenance of the Honda H4013 lawn tractor, type SA. All information in this publication is based on the latest product information available at the time of printing.

Honda Motor Co., Ltd. reserves the right to make changes at any time without notice and without incurring any obligation.

No part of this publication may be reproduced without written permission.

This manual is considered a permanent part of the lawn tractor and it must stay with the lawn tractor if resold.

READ THIS OWNER'S MANUAL CAREFULLY. Pay special attention to these symbols and any instructions that follow:

▲ DANGER

—Indicates serious injury or death **WILL** result if instructions are not followed.

▲ WARNING

—Indicates a strong possibility that serious injury or death could result if instructions are not followed.

▲ CAUTION

—Indicates a possibility that minor injury can result if instructions are not followed.

IMPORTANT NOTICE

—Indicates that equipment or property damage can result if instructions are not followed.

NOTE: Gives helpful information.

Honda lawn tractors are designed to give safe and dependable service if operated according to instructions. Operating this lawn tractor requires special effort on your part to ensure your safety and the safety of others.

▲ WARNING

Using this product for a purpose not intended may cause injury or property damage. Read and understand this Owner's Manual before operating this lawn tractor.

If a problem should arise, or if you have any questions about your lawn tractor, consult an authorized Honda lawn tractor dealer.

HONDA MOTOR CO., LTD. 1989, ALL RIGHTS RESERVED

CONTENTS

1. SAFETY INFORMATION	4
2. COMPONENT IDENTIFICATION	8
3. CONTROLS	10
Engine switch	10
Throttle lever	10
Cutter deck height adjusting lever	11
Shift lever	12
Power take-off (P.T.O.) lever	13
Brake pedal	13
Parking brake lever and warning buzzer	14
4. PRE-OPERATION CHECKS	15
Dust screen	15
Engine oil	16
Gasoline	17
Gasolines containing alcohol	19
Air cleaner	20
Battery	21
Brake	22
Cutter deck	23
Cutter deck drive belt and blade belt	23
Anti-scalp roller adjustment	24
Tires	25
Seat adjustment	25
Blade	26
Safety switch	28
5. OPERATION	29
Starting the engine	29
Seat safety switch operation check	31
Parking brake system inspection	31
Mowing	32
Mowing tips	32
Starting the lawn tractor	34
Cutting patterns	36
Operating on hills	38
Stopping the engine	39
High altitude operation	40
6. TRANSPORTING	41
Transporting	41
Towing	42

7. MAINTENANCE	44
Maintenance schedule	45
Engine oil change	46
Air cleaner service	47
Spark plug service	48
Battery service	50
Wheel removal	52
Cutter deck removal	53
Cutter deck drive belt replacement	56
Blade belt replacement	57
Blade bolt tightness/Blade replacement	58
Spark arrester maintenance (optional part)	60
Fuse replacement	61
Fuel filter	62
Transmission oil	62
8. LONG TERM STORAGE	63
Preparation for storage	63
Removal from storage	65
9. TROUBLESHOOTING	66
10. SPECIFICATIONS	70
11. WIRING DIAGRAM	71
12. WARRANTY SERVICE	72

1. SAFETY INFORMATION

Read all safety instructions before operating.

⚠ WARNING

LAWN TRACTORS CAN BE HAZARDOUS IF OPERATED IMPROPERLY.

TO AVOID SERIOUS INJURY, READ ALL SAFETY INSTRUCTIONS CAREFULLY.

- READ OWNER'S MANUAL BEFORE OPERATION
- THE OWNER'S MANUAL HAS IMPORTANT SAFETY AND OPERATION INFORMATION.
- LEARN THE LOCATION AND FUNCTION OF ALL CONTROLS.
- IN AN EMERGENCY YOU SHOULD BE ABLE TO OPERATE THEM QUICKLY.
- DO NOT ALLOW CHILDREN TO OPERATE OR PLAY WITH THE TRACTOR OR ITS CONTROLS.
- THE MOWER BLADE IS SHARP
- BE SURE BLADE AND ENGINE ARE STOPPED COMPLETELY BEFORE PLACING HANDS OR FEET NEAR THE BLADE.
- THROWN OBJECTS CAN CAUSE INJURY.
- BEFORE MOWING, REMOVE ALL DEBRIS FROM THE AREA. BE SURE GUARDS ARE IN PLACE, AND KEEP CHILDREN AND PETS AWAY.
- EXCEEDING THE MAXIMUM SAFE OPERATING ANGLE MAY CAUSE THE TRACTOR TO TIP-OVER. REDUCE SPEED WHEN TURNING OR OPERATING ON SLOPES.



10° MAX
10 DEGREES (17% GRADE)
101-1004

⚠ WARNING

GASOLINE IS FLAMMABLE. STOP ENGINE, AVOID HEAT, SPARKS, AND OPEN FLAME WHEN REFUELING.

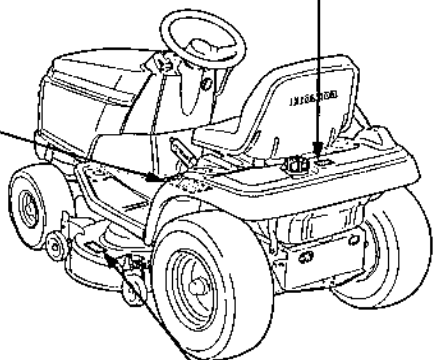

⚠ DANGER

ROTATING BLADE. KEEP HANDS AND FEET AWAY FROM MOWER AND DISCHARGE GUARD WHILE BLADE IS TURNING.



⚠ DANGER

ROTATING BLADE. KEEP HANDS AND FEET AWAY FROM MOWER AND DISCHARGE GUARD WHILE BLADE IS TURNING.



⚠ DANGER

THROWN OBJECTS. OBJECTS THROWN BY THE MOWER CAN CAUSE INJURY OR DEATH.

- CLEAR LAWN OF ALL DEBRIS.
- BE SURE DISCHARGE GUARD OR CHUTE ARE IN PLACE.
- KEEP PEOPLE AND PETS AWAY.

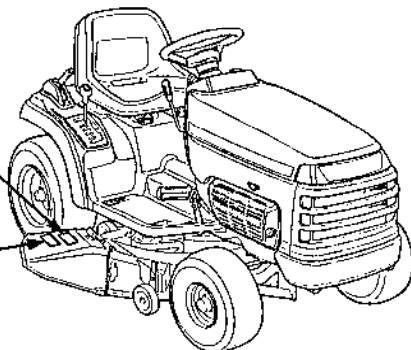

SAFETY INFORMATION

For your safety and the safety of others, pay special attention to these precautions:

Operator Responsibility

- Keep the lawn tractor in good operating condition. Operating a lawn tractor that is in poor, or questionable condition could result in serious injury.
- Be sure all safety devices are in working order and that warning labels are in place, these items are installed for your safety.
- Know how to stop the engine and blades quickly in case of emergency. Understand the use of all controls.
- Allowing anyone to operate this lawn tractor without proper instruction may result in injury.
- Allowing passengers to ride on the tractor or any of its attachments may cause the tractor to tip over.
- Wear sturdy, full coverage footwear. Operating this tractor with bare feet, or with open toe shoes or sandals increases your risk of injury.
- Dress sensibly. Loose clothing may get caught in moving parts, increasing your risk of injury.
- Be alert. Operating this lawn tractor when you are tired, ill or under the influence of alcohol or drugs may result in serious injury.
- Keep all persons and pets away from the mowing area.

Child Safety

Serious injury or death can occur if a child falls off the tractor or runs into the tractor's path and is run over by the machine.

- Allowing children to ride as passengers on the lawn tractor can be dangerous.
- Keep children indoors and supervised at all times when any outdoor power equipment is being used nearby. Young children move quickly and are attracted to the tractor and the mowing activity especially if they have been given rides before.
- Never assume that children will remain where you last saw them. Be alert, and turn the mower off if children enter the area. Use extreme care when backing up, and when approaching corners, shrubs, trees, and other obstructions that might hide children from sight.
- Children should never be allowed to operate the lawn tractor, even under adult supervision.

Cutting Blade Hazard

The cutting blades are sharp, and they turn at high speed. Accidental contact can cause serious injury.

- Keep your hands and feet away from the mower deck while the engine is running.
- Stop the engine, disengage the Power Take Off (P.T.O.) clutch and remove the key before inspection or maintenance of the deck or blades.
- Disconnect the spark plug cap to prevent any possibility of accidental starting. Wear heavy gloves to protect your hands from the blades when cleaning out the mower deck, or when inspecting or replacing the blades.

Thrown Object Hazard

Objects hit by the cutting blades can be thrown from the tractor with great force, and may cause serious injury.

- Before mowing, clear the mowing area of sticks, stones, dog bones, and other litter and loose objects. Mow only in daylight, or in well-lit areas at night, so you can see and avoid objects in the grass.
- Before operating the tractor, be sure the side discharge guard is down, or that the optional grass catcher bags and discharge chute are in place.
- Disengage the Power Take Off (P.T.O.) lever to stop the blades before crossing a gravel driveway or any other area with loose stones.
- Always inspect the mower for damage after striking a foreign object. Repair or replace any damaged parts before continued use.
- Broken pieces thrown from a worn or damaged blade can cause serious injury. Always inspect the blades before using the tractor.

Fire and Burn Hazard

Gasoline is extremely flammable, and gasoline vapor can explode. Use extreme care when handling gasoline. Keep gasoline out of reach of children.

- Refuel in a well ventilated area with the engine stopped.
- Allowed the engine to cool before refueling. Fuel vapor or spilled fuel may ignite.
- Dry grass and leaves may ignite if they are allowed to accumulate around the engine, the exhaust system, or on top of the cutter deck (especially around the pulleys).
- It is illegal in some areas to operate an engine without a USDA qualified spark arrester. Periodic maintenance is required to keep a spark arrester functioning as designed.

The engine and exhaust system become very hot during operation and remain hot for a while after stopping. Contact with hot engine components can cause burn injuries and can ignite some materials.

- Avoid touching a hot engine or exhaust system.
- Allow the engine to cool before performing maintenance or storing the lawn tractor indoors.

Carbon Monoxide Poisoning Hazard

Exhaust contains poisonous carbon monoxide, a colorless and odorless gas. Breathing exhaust can cause loss of consciousness and may lead to death.

- If you run the engine in an area that is confined, or even partially enclosed, the air you breathe could contain a dangerous amount of exhaust gas. To keep exhaust gas from building up, provide adequate ventilation.

Towing Hazard

Towing trailers, garden carts, etc. will affect the stability of the tractor. Use the proper type of hitch, and never exceed the recommended load limit and tongue weight. Refer to the recommendations on pages 42 and 43 of this manual.

Operation on Slopes

This lawn tractor is intended for use on relatively flat terrain. Operating the lawn tractor on slopes exceeding 10 degrees (17% grade) could cause the mower to tip over.

NOTE: If you feel that you cannot accurately judge the angle of the grade to be mowed, we suggest that you obtain an inclinometer. These slope gauges are available at most hardware stores.

- When mowing on slopes, empty the grass bags when they are half full. The weight of full grass bags may cause the lawn tractor to tip over.

Maximum safe operating angle

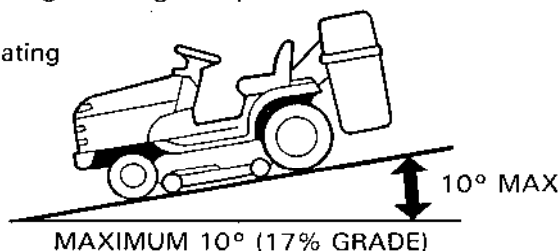

2. COMPONENT IDENTIFICATION

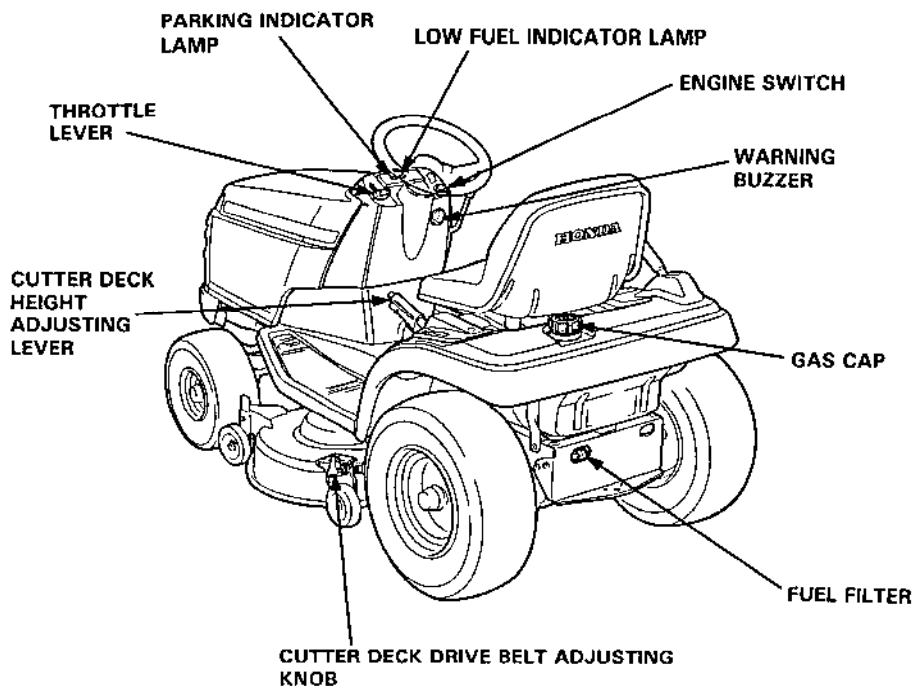
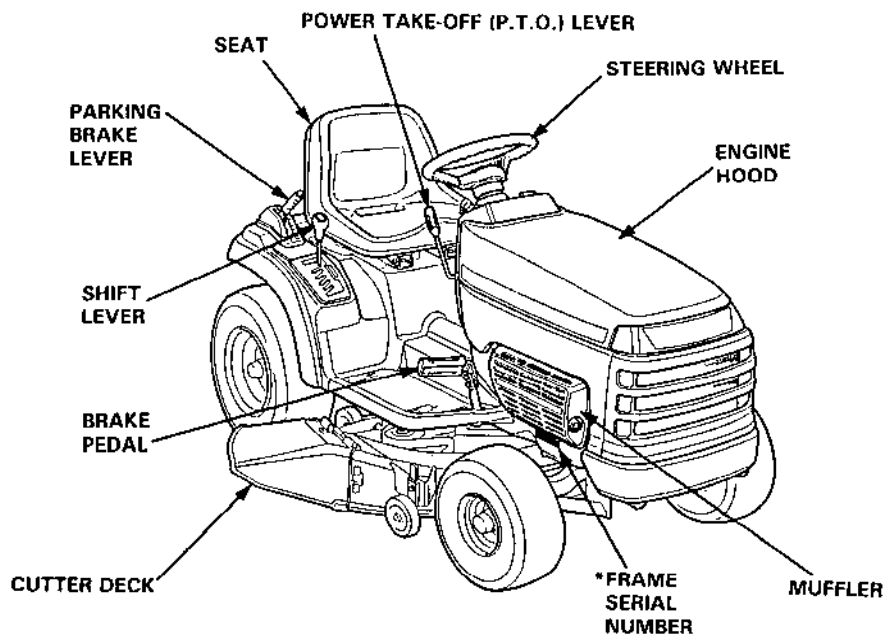

Engine compartment

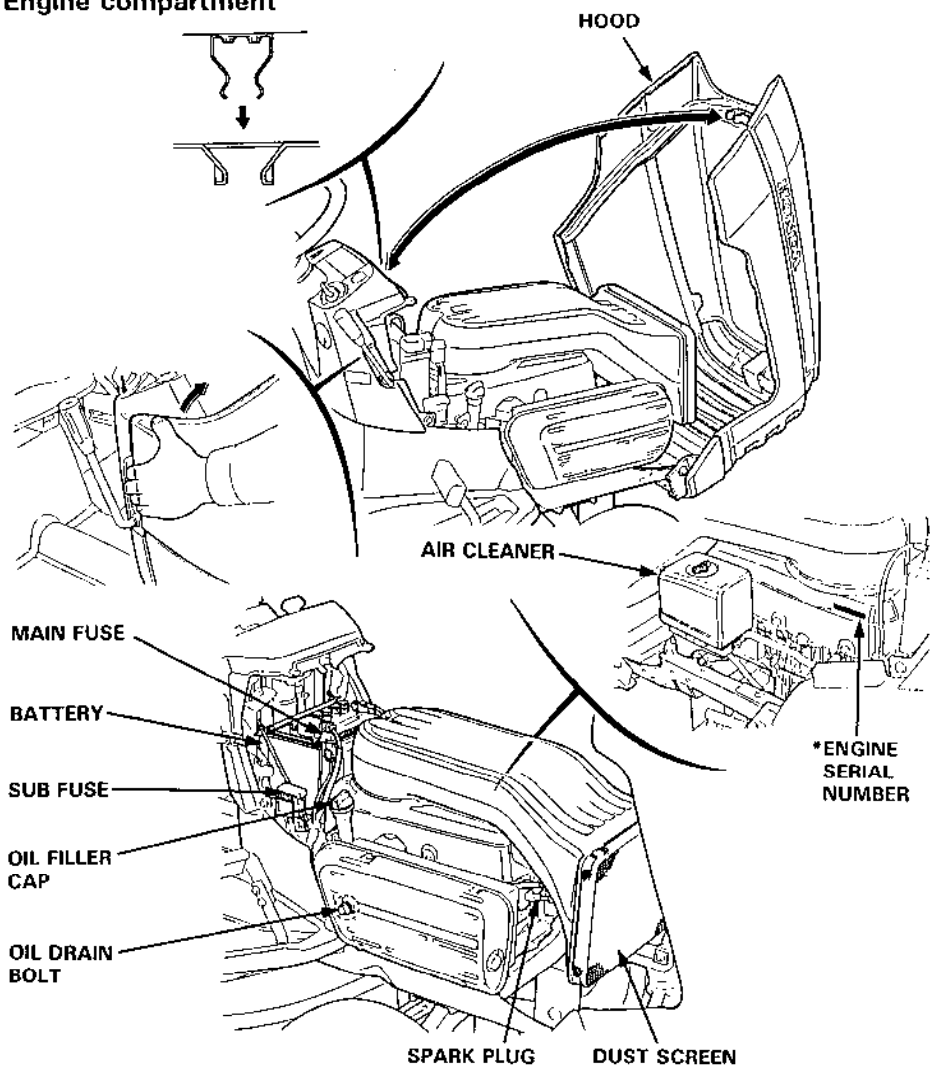

* Record the frame and engine serial numbers for your reference. Refer to the serial numbers when ordering parts, and when making technical or warranty inquiries (see page 72).

Frame serial number: _____

Engine serial number: _____

3. CONTROLS

Engine switch

⚠ WARNING Always remove the key from the engine switch whenever the lawn tractor is unattended to prevent children or unauthorized persons from starting the engine.

This lawn tractor is equipped with an automotive type ignition switch, which controls all the electrical circuits. The switch is located on the right-hand side of the control panel.

Key positions: "START" to start the engine
"ON" to run the engine after starting
"OFF" to stop the engine.

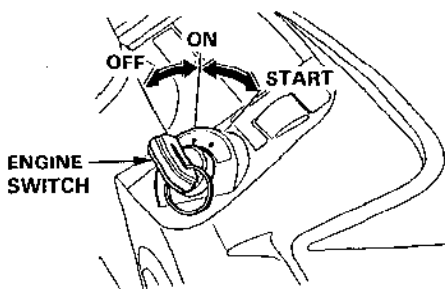

IMPORTANT NOTICE Do not leave the engine switch "ON" (key on "ON" position) when the engine is not running as the battery will discharge.

NOTE: The starter motor will not operate unless the shift lever is in NEUTRAL, and the P.T.O. lever is in the OFF (disengaged) position.

Throttle lever

The throttle lever controls engine speed from SLOW (idle) to FAST (max speed). START (CHOKE) is for starting a cold engine.

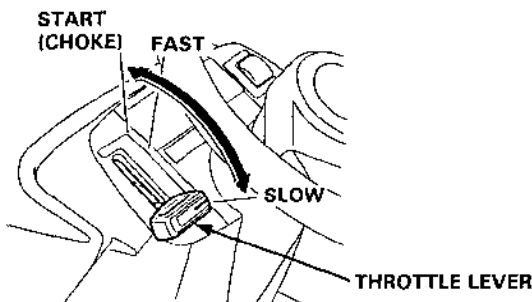

Cutter deck height adjusting lever

This lever is used to raise and lower the cutter deck. To adjust the cutting height, squeeze the handle lock and then press in and hold the set button. Raise or lower the lever until the desired cutting height appears on the indicator. At that point, release the set button and the handle lock. Be sure the handle lock returns to its normal position when released.

Cutting height: 1.0, 1.5, 2.0, 2.5, 3.0, 3.5, 4.0 inches (Approx.)

IMPORTANT NOTICE

- To avoid damage to the cutter deck, always raise it fully when driving the lawn tractor to and from the mowing area; this provides maximum ground clearance.
- To avoid damaging or disabling the handle locking mechanism, never attempt to screw the adjusting lever's set button in or out.

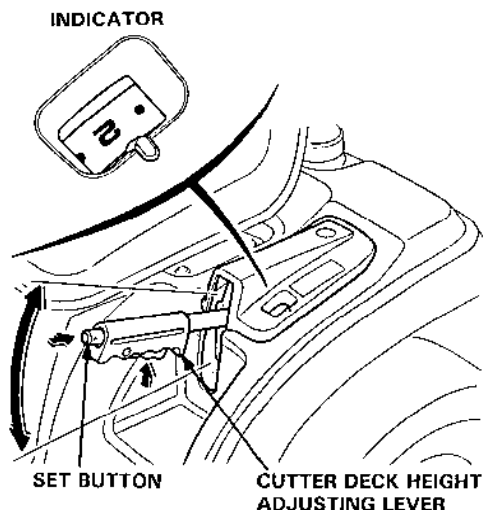

Shift lever

This lever is used to select one of the five forward speeds, neutral or reverse. The drive clutch automatically disengages while the lever is being moved. The clutch will then engage automatically when a gear is selected unless the brake pedal is depressed.

⚠ WARNING Improper use of the shift lever on slopes may cause loss of control which could lead to injury. See page 38.

IMPORTANT NOTICE Improper shift lever operation can damage the transmission.

Bring the lawn tractor to a complete stop before shifting from a forward speed to reverse, or from reverse to forward speed. Shifting between forward and reverse speeds while the tractor is moving can cause transmission damage.

When shifting from one forward speed range to another while moving, do not force the shift lever and do not shift up or down more than one slot at a time.

NOTE: The lawn tractor will pull away from a stop in any speed range. No shifting is necessary.

Be sure that the shift lever is in the MOWING range whenever mowing.

Mowing in the 5th or 4th speed range is not recommended; as this will affect cut quality. 5th and 4th speed range should only be used to drive to and from the mowing area.

NOTE: An interlock switch prevents the engine from starting unless the shift lever is in the N (neutral) position.

SHIFT LEVER

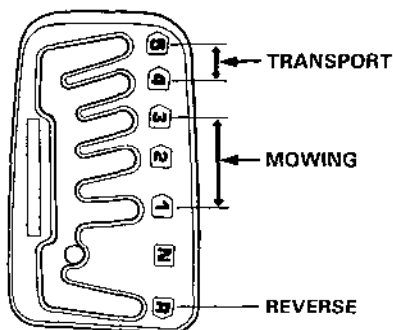
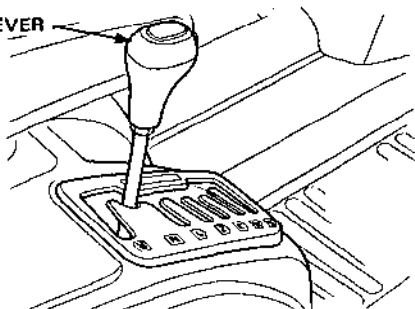

Power Take-Off (P.T.O.) lever

This lever engages and disengages the power take-off clutch to drive the blades.

Lever positions: ON (Engaged)..... Blades turn
OFF (Disengaged).... Blade stop

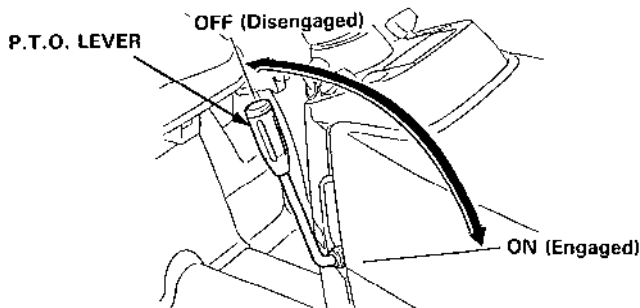

NOTE: An interlock switch prevents the engine from starting unless the P.T.O. lever is in the OFF position.

Brake pedal

Depressing the pedal will first disengage the drive clutch. As you continue to depress the pedal, the brake will be applied to stop the tractor.

When the brake pedal is released, an automatic mechanism gradually engages the clutch.

IMPORTANT NOTICE Releasing the brake pedal too slowly or holding the pedal halfway out, can cause the clutch to slip, and may lead to premature clutch wear.

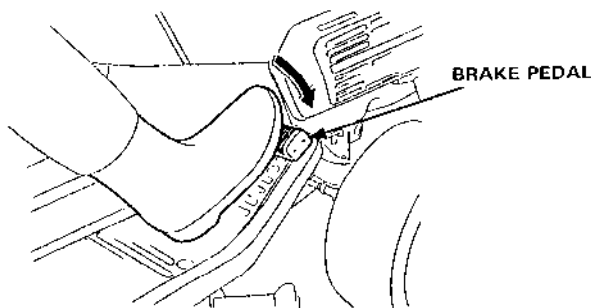

Parking brake lever and warning buzzer

This lever is used to set the brake when the lawn tractor is parked. To set the parking brake, pull the lever fully up until the ratchet locks, and be sure that the parking indicator lamp on the control panel is ON.

To release the parking brake, pull the lever up slightly and press the set button, lower the lever while holding in the button.

The warning buzzer will sound if the seated operator moves the shift lever out of the neutral position while the parking brake is set, and engine switch is in the "ON" position. Releasing the parking brake lever will stop the buzzer.

A delayed engine cutoff is interlinked with the parking brake warning buzzer. This feature prevents the lawn tractor from being operated while the parking brake is set. The engine will stop a few seconds after the warning buzzer begins to sound unless the parking brake is released.

IMPORTANT NOTICE When washing the lawn tractor, do not spray water directly into the warning buzzer.

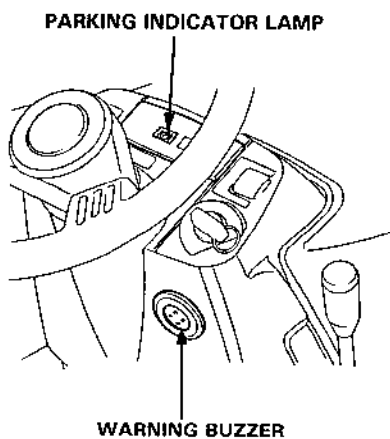
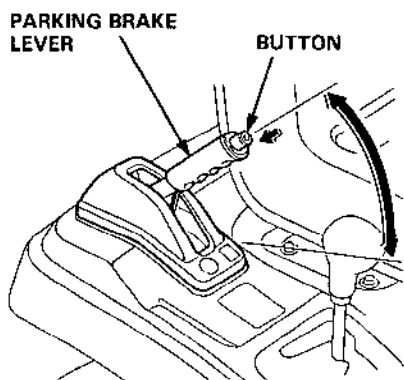

4. PRE-OPERATION CHECKS

Follow the procedures below and check all of the following items before each use:

1. Park the lawn tractor on a level surface.
2. Place the shift lever in the neutral position and set the parking brake.
3. Disconnect the spark plug cap and remove the engine switch key to prevent accidental engine start-up.

▲ WARNING If the engine is started accidentally while you are performing the pre-operation checks, moving parts may cause serious injury.

Dust screen

▲ WARNING If the engine has been running, the engine and muffler will be very hot; allow them to cool before proceeding.

1. Open the engine hood.
2. Clean the screen.

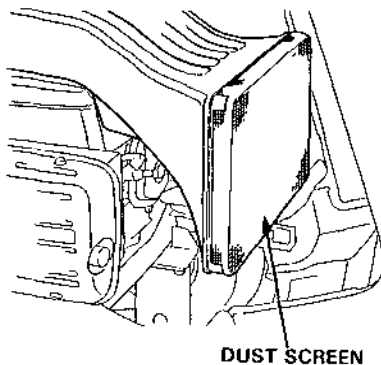
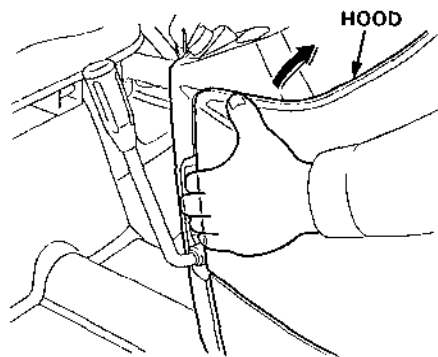

ENGINE OIL

IMPORTANT NOTICE Running the engine with low oil level will cause serious engine damage.

1. Place the lawn tractor on a level surface.
2. Open the engine hood, wipe dust and dirt from around the oil filler cap, remove the cap and wipe the dipstick clean.
3. Insert the dipstick into the oil filler neck, but do not screw it in.
4. If the level is low, add the recommended oil to the upper mark on the dipstick. Do not overfill.

Use high-detergent, premium quality 4-stroke engine oil, certified to meet or exceed U.S. automobile manufacturer's requirements for API Service Classification SG, SF/CC, CD.

IMPORTANT NOTICE Using nondetergent oil or 2-stroke engine oil could shorten the engine's service life.

SAE 10W-30 is recommended for general, all-temperature use. Other viscosities shown in the following chart may be used when the average temperature in your area is within the indicated range.

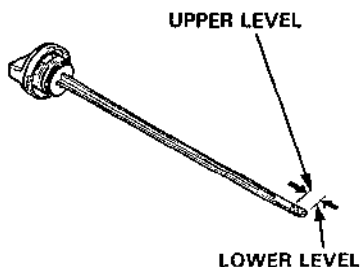
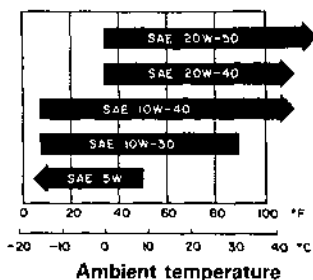
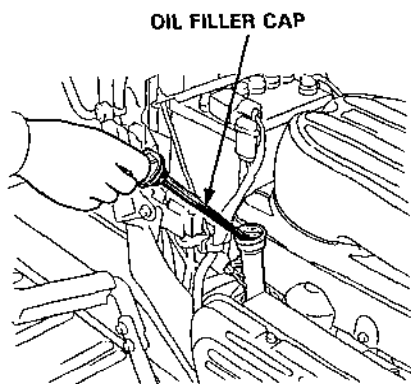

GASOLINE

Remove the gas cap and check the fuel level. Refill the tank if the level is low.

If the low fuel indicator lamp glows, it means you have about 1.0 ℓ (0.26 US gal) or less remaining and should refuel.

Gas tank capacity: 9.0 ℓ (2.38 US gal, 1.98 Imp gal)

▲ WARNING

Gasoline is extremely flammable, and gasoline vapor can explode. Use extreme care when handling gasoline. Keep gasoline out of reach of children.

- Refuel in a well ventilated area with the engine stopped. Keep flames and sparks away, and do not smoke in the area.
- Gasoline vapors or spilled gasoline may ignite.
- Refuel carefully to avoid spilling gasoline. Avoid overfilling the fuel tank (there should be no gas in the filler neck). After refueling, tighten the gas cap securely. If any gasoline was spilled, make sure the area is dry before starting the engine.
- After use, park the lawn tractor on a level surface. Be sure the storage area is well ventilated, do not allow flames or sparks in the storage area.

After refueling, be sure to tighten the gas cap firmly.

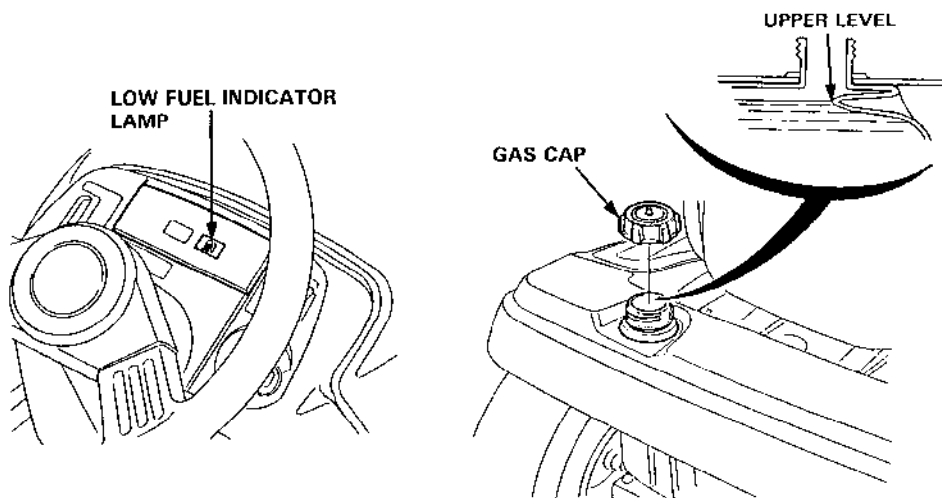

Gasoline Recommendation

Pump octane rating: 86 or higher

We recommend unleaded gasoline because it produces fewer engine and spark plug deposits and extends the exhaust system life.

If "spark knock" (metallic rapping noise) or persistent "pinging" occurs at a steady engine speed under normal load, change brands of gasoline. If spark knock or pinging persists, see an authorized Honda lawn tractor dealer.

IMPORTANT NOTICE Running the engine with persistent spark knock or pinging can cause engine damage.

Running the engine with persistent spark knock or pinging is considered misuse, and the Distributor's Limited Warranty does not cover parts damaged by misuse.

Occasionally you may hear light spark knock while operating under heavy loads. This is no cause for concern. It simply means your engine is operating efficiently.

Never use stale or contaminated gasoline or an oil/gasoline mixture. Avoid getting dirt or water in the gas tank.

GASOLINES CONTAINING ALCOHOL

If you decide to use a gasoline containing alcohol (gasohol), be sure its octane rating is at least as high as that recommended by Honda (see Gasoline Recommendation on page 18). There are two types of "gasohol": one containing ethanol, and the other containing methanol.

IMPORTANT NOTICE Using gasohol that contains more than 10% ethanol, or gasoline containing methanol (methyl or wood alcohol) that does not also contain cosolvents and corrosion inhibitors for methanol, can cause serious fuel system damage and poor engine performance.

Never use gasoline containing more than 5% methanol, even if it has cosolvents and corrosion inhibitors.

Honda cannot endorse the use of gasoline containing methanol since evidence of its suitability is as yet incomplete.

NOTE: Fuel system damage or engine performance problems resulting from the use of gasoline that contains alcohol is not covered under the warranty.

Before buying gasoline from an unfamiliar station, first determine if the gasoline contains alcohol; if it does, find out the type and percentage of alcohol used.

NOTE: If you notice any undesirable operating symptoms while using a gasoline that contains alcohol, or one that you think contains alcohol, switch to a gasoline that you know does not contain alcohol.

Air cleaner

Check that the air cleaner elements are clean and in good condition. A dirty air cleaner will restrict air flow to the carburetor, reducing engine performance. A damaged air cleaner will allow dirt to enter the engine, causing rapid engine wear.

1. Open the engine hood, and remove the wing nut to remove the air cleaner cover and air cleaner elements.
2. Inspect the air cleaner elements. Clean or replace the elements if necessary. If the air cleaner elements need cleaning, follow the procedure described on page 47.
3. Reinstall the air cleaner elements and air cleaner cover. Tighten the wing nut.

IMPORTANT NOTICE Operating the engine without an air cleaner will cause rapid engine wear.

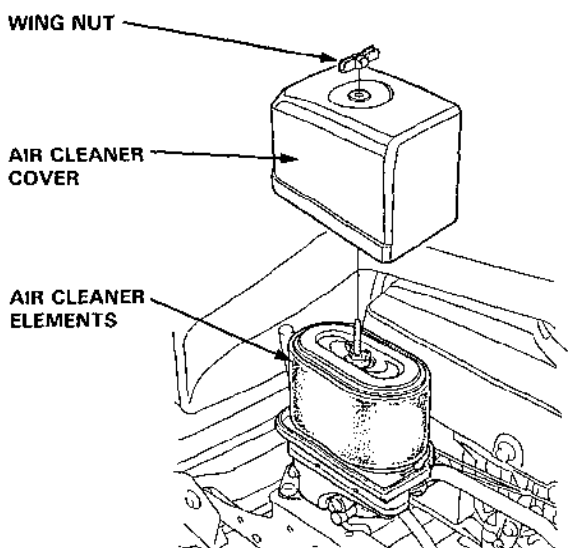

Battery

Open the hood, and check the battery electrolyte level.

The electrolyte level must be kept between the UPPER and LOWER level marks. If the electrolyte level is near the LOWER mark, remove the battery filler caps and carefully add distilled water to each cell until the liquid reaches the UPPER level mark (see page 50).

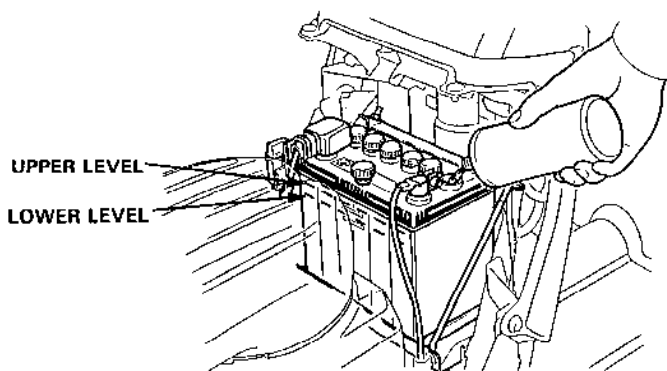

⚠ WARNING

Batteries produce explosive gases. Flames or sparks can cause an explosion, causing serious injury or blindness. Keep flames and sparks away and provide adequate ventilation when charging.

- **CHEMICAL HAZARD:** Battery electrolyte contains sulfuric acid. Contact with eyes or skin, even through clothing, may cause severe burns. Wear a faceshield and protective clothing.
ANTIDOTE: If electrolyte gets into your eyes, flush thoroughly with warm water for at least 15 minutes and call a physician immediately.
- **POISON:** Electrolyte is poison.
ANTIDOTE
 - External: Flush thoroughly with water.
 - Internal: Drink large quantities of water or milk.
Follow with milk of magnesia or vegetable oil, and call a physician immediately.
- **KEEP OUT OF REACH OF CHILDREN.**

Brake

Inspect brake lining condition every time the lawn tractor is used. Firmly set the parking brake, and then check the position of the brake wear indicator. If the indicator is near the wear limit, take the lawn tractor to an authorized Honda lawn tractor dealer for repair.

⚠ WARNING Under no circumstances should the lawn tractor be operated if the brake lining is at or past the service limit.

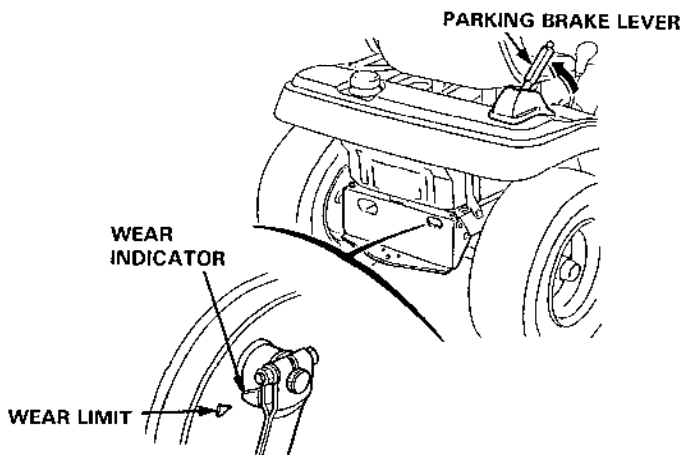

Cutter deck

Prior to using the mower, be sure to check that dirt, mud, and grass have not built up in the deck. For cleaning, refer to page 65.

Cutter deck drive belt and blade belt

■ INSPECTION

1. Lower the cutter deck by using the cutter deck height adjusting lever.
2. Inspect the belts for damage or excessive wear. If the belts are damaged or excessively worn, replace them as described on pages 56 and 57.

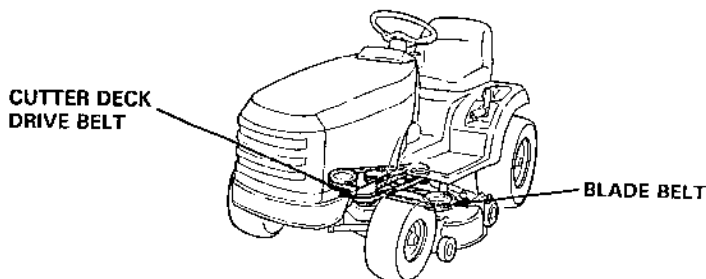

• Cutter deck drive belt tension

1. Lower the cutter deck as far as it will go with the cutter deck height adjusting lever.
2. Check belt tension by looking at the location of the tension indicator pin on the tensioner arm. The tension is OK as long as the pin is between the tension alignment mark and the low tension indicator mark. If the pin is not between the marks, follow the steps below:
 - a. Loosen the lock nut.
 - b. Turn the belt tension adjusting knob until the pin aligns with the tension alignment mark.

NOTE: If it is not possible to align the pin with the tension alignment mark, replace the deck drive belt.

 - c. Tighten the lock nut.

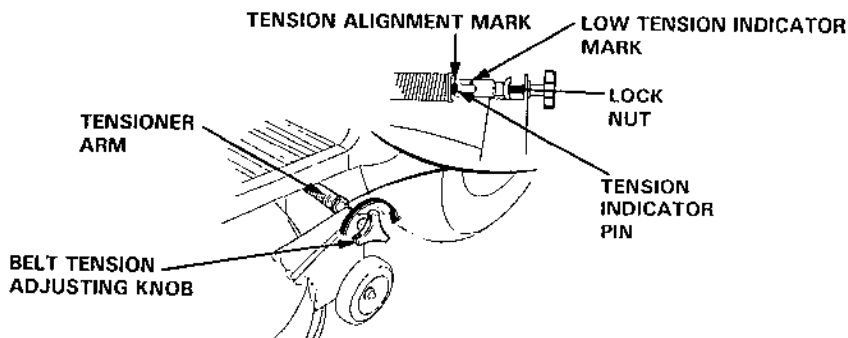

Anti-scalp roller adjustment

The anti-scalp rollers help to prevent the blades from gouging or "scalping" high spots. The deck is designed to "float", and it is important to set the anti-scalp rollers correctly. The setting depends on the type of terrain being mowed and the cut height.

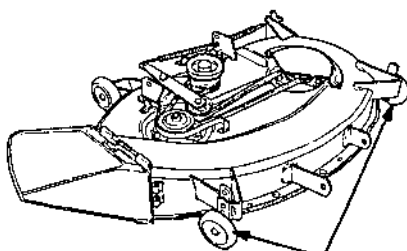

ANTI-SCALP
REOLLERS

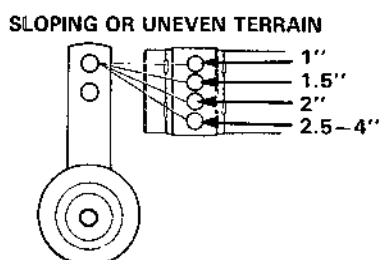
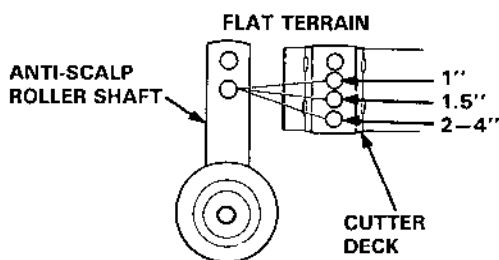

For flat terrain, use the lower hole in the anti-scalp roller shaft. Align the hole with the hole on the deck that corresponds to the selected cutting height as shown.

For sloping or uneven terrain, use the upper hole in the anti-scalp roller shaft. Align the hole with the mounting hole that corresponds to the selected cutting height as shown.

NOTE: Use the lower three mounting holes only.

If the cut height is set at 1 inch, move both rear anti-scalp roller shafts to the upper holes as shown. Tighten the nuts securely.

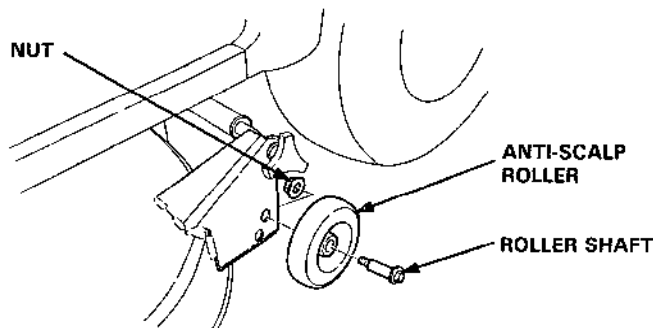

Tires

IMPORTANT NOTICE Overinflation can cause premature tire failure.
Inflate the tires to manufacturer's recommended tire pressure.

Check the tire pressure with an air pressure gauge.

Pressure: Front 1.0 kg/cm² (14 psi)

Rear 0.8 kg/cm² (11 psi)

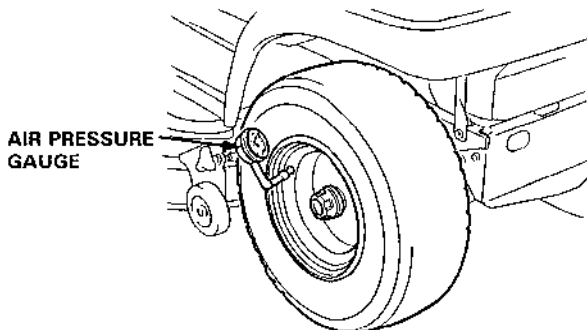

Seat adjustment

1. Loosen the four seat mounting nuts with the spark plug wrench provided.
2. Move the seat to a position that allows you to reach all controls easily and comfortably.
3. Tighten the seat mounting nuts securely.

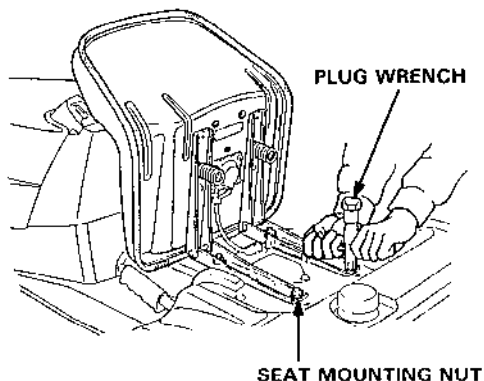

Blade

Before each use, inspect the blades for damage or excessive wear.

▲ WARNING

- Remove the engine switch key and disconnect the spark plug cap to prevent accidental starting.
 - Wear heavy gloves to protect your hands from the blades.
1. Set the parking brake, and move the P.T.O. lever to the OFF (disengaged) position.
 2. Raise the deck height adjusting lever as high as it will go.
 3. Inspect the blades for cracks, bending and wear;
 - The right blade can be seen through the discharge opening.
 - The left blade can be seen under the left side of the deck.
 4. Rotate the blades 180° and inspect the other sides.

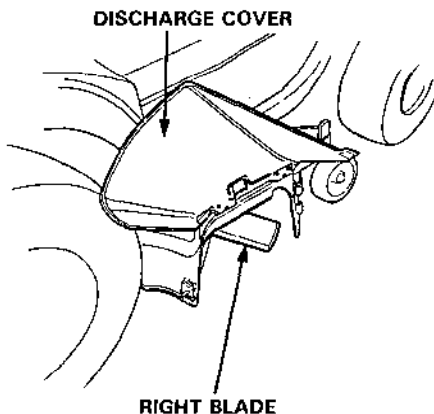
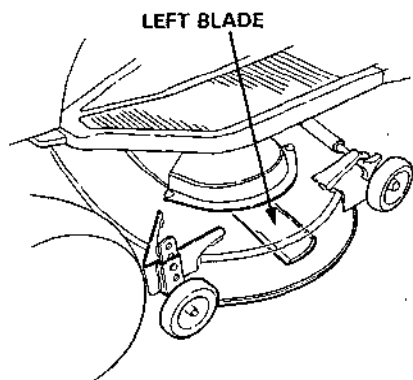

4. If either of the blades shows signs of damage or excessive wear, remove the cutter deck, and thoroughly inspect the blades (see cutter deck removal instructions on pages 53 and 54). Dull blades can be sharpened, but blades that are worn out, bent, cracked, or otherwise damaged must be replaced. If the blades need sharpening or replacement, take the cutter deck to your authorized Honda lawn tractor dealer. Or, if you have the proper tools, you can remove and install the blades yourself (see blade removal and installation instructions on pages 58 and 59).

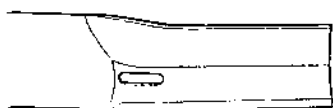

NORMAL

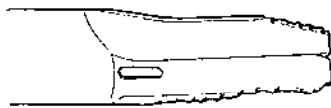

EXCESSIVELY WORN

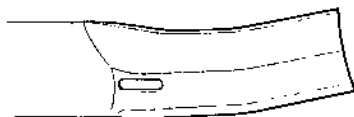

BENT

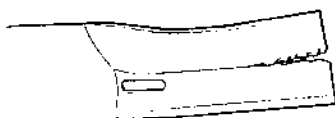

CRACKED

▲ WARNING Broken pieces thrown from a worn or damaged blade can cause serious injury. Always inspect the blades before using the tractor.

IMPORTANT NOTICE

- Use genuine Honda replacement blades, or equivalent.
- To reduce the possibility of weakening the blades, or causing imbalance or poor cutting performance, sharpening should be performed by an authorized Honda lawn tractor dealer.

Safety switch

Before performing these inspections, remove the spark plug cap.

1. P.T.O. switch inspection

- With the shift lever in the N (Neutral) position, set the P.T.O. lever in the ON (Engaged) position.
- Check that the starter motor does not operate when the engine switch is turned to the START position.
- Return the P.T.O. lever to the OFF (Disengaged) position.

2. Neutral switch inspection

- With the P.T.O. lever in the OFF (Disengaged) position, set the shift lever in the MOWING range.
- Check that the starter motor does not operate when the engine switch is turned to the START position.
- Return the shift lever to the N (Neutral) position.

Starting the engine

⚠ WARNING

Exhaust contains poisonous carbon monoxide gas that can cause loss of consciousness and may lead to death. Never run the engine in an enclosed area. Be sure to provide adequate ventilation.

1. Sit on the seat and check that the parking brake lever is set, the transmission is in neutral and the P.T.O. lever is in the OFF (disengaged) position.
2. Move the throttle lever to the START (CHOKE) position.

NOTE: When the engine is warm or the air temperature is high, move the throttle lever to SLOW.

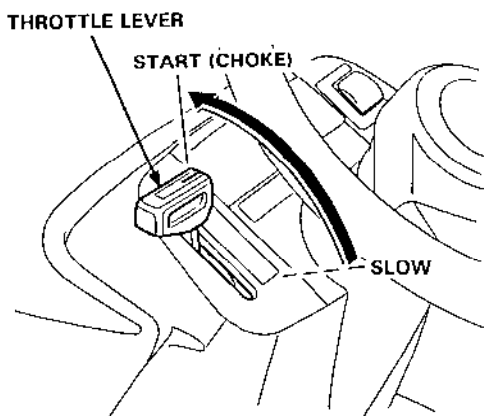

3. Turn the engine switch to START. (5 seconds maximum)

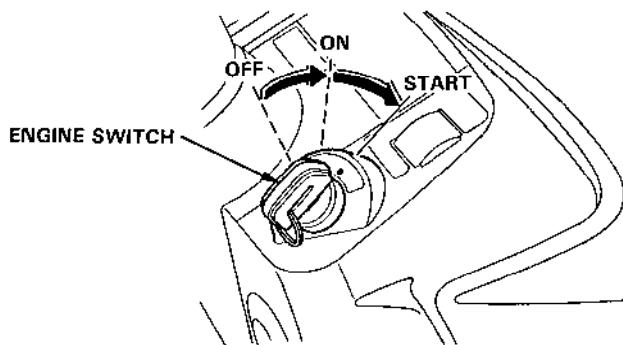

IMPORTANT NOTICE Running the starter motor for more than 5 seconds can damage the motor.

If the engine fails to start, release the engine switch key, and wait at least 10 seconds before operating the starter motor again.

4. After the engine starts, let the engine switch return to ON.
5. After the engine warms up, move the throttle lever to the SLOW position.

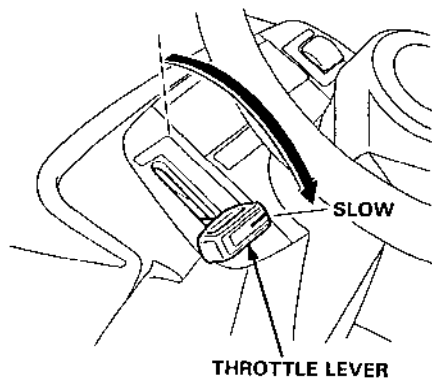

Seat safety switch operation check

The seat safety switch automatically stops the engine if the operator's weight is off the seat when the following interlocks are actuated.

1. While parked on a level surface, start the engine, and move the P.T.O. lever to ON (Engaged).
Rise off the seat; the engine should stop.
2. Return the P.T.O. lever to OFF (Disengaged) and restart the engine. Release the parking brake and shift the transmission into 1st gear. While driving slowly, raise off the seat — the engine should stop immediately.

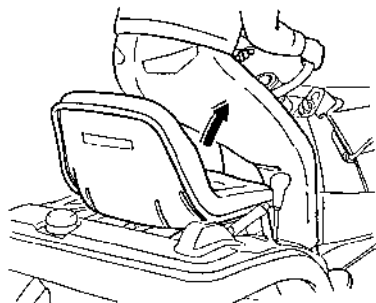

Parking brake system inspection

1. Set the parking brake.
2. Start the engine.
3. Shift the transmission into gear. Then make sure that the warning buzzer sounds, and the engine stops after a few seconds.
4. Shift the transmission into neutral and turn the engine switch to OFF.

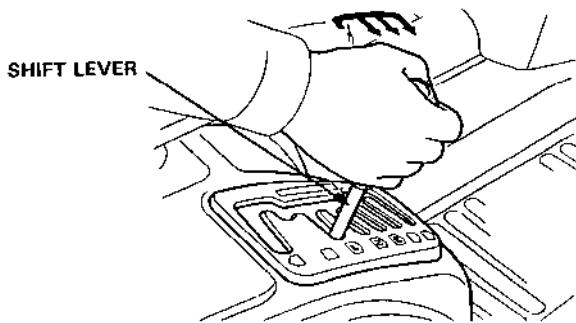

If the inspection shows that the operation of the safety switches is abnormal, contact an authorized Honda lawn tractor dealer.

Mowing

Before operating this lawn tractor, you should read and understand the SAFETY INSTRUCTIONS on pages 4–7.

▲ WARNING

- Rotating blades and thrown objects can cause serious injury. Always stop the engine before clearing the discharge chute or removing the grass bags.
- Unseen hazards may cause loss of control or damage to the lawn tractor. Look for and avoid rocks, roots, holes, and hidden hazards in the terrain.
- Operating the lawn tractor near the edge of a ditch or an embankment could cause it to tip or roll over.
- Sharp turns, rapid acceleration, and sudden stops can cause the tractor to tip or roll over on sloping surfaces. Also, avoid backing down slopes.
- Decomposing grass creates heat, and may become a fire hazard. Always empty the grass bags before storing the tractor.

When mowing tall grass, make a first pass with the deck fully raised (4); this will help to expose any hidden obstacles. When you are sure that the area is completely cleared, mow again at the desired height.

IMPORTANT NOTICE If the lawn tractor accidentally gets caught on an object (rock, root, hole, etc.), do not attempt to ride over the object or turn the steering wheel to free the mower. These actions can damage the steering mechanism or the deck.

Mowing tips

- For best results mow when the grass is dry, and the ground is slightly damp to control dust.
- Wet grass will clog the deck and the discharge chute; this will cause poor cut quality.
- If dust is a problem, water the lawn the day before you mow.
- To avoid leaving uncut grass, engage the P.T.O. before shifting the transmission from neutral to the desired mowing speed.

-
- For best cut quality and overall performance, set the throttle in the FAST position and select the proper mowing speed with the shift lever. Mowing at low or medium throttle setting will affect blade performance and cut quality.
 - For best results, select a good mowing speed and stay at that speed. Rapid speed changes while mowing will affect cut quality.
 - Do not shift the transmission to 4th or 5th gear (TRANSPORT range) while mowing as this will affect cut quality. Use this speed range (4th and 5th; TRANSPORT RANGE) only for driving the lawn tractor to and from the mowing area.
 - When cutting thick, lush or uneven grass, raise the deck, reduce mowing speed and increase the overlap width (see page 37).
 - For best results, and to reduce the load on the engine, mow grass before it reaches 6 inches in length.
 - If it is necessary to mow grass that is more than 6 inches long, reduce mowing speed, and mow twice: once with the deck raised as high as it will go (4), and then a second time with the deck set at the desired height.
 - It is best to remove leaf clutter and dried clippings from the lawn before mowing. To do this, select a cutter deck height setting that positions the lower edge of the deck one inch or less above the surface of the lawn, and then make a low speed pass to pick up the surface debris.

NOTE: If your tractor is not equipped with optional grass bags:

1. Divide the lawn into square blocks. The size of the blocks should depend on the amount of debris: the more debris, the smaller the blocks.
 2. Select a slow MOWING speed, and drive the tractor in a clockwise pattern from the outside to the inside of each square. The side discharge chute will concentrate the debris in the center for easier removal.
- When trimming, reduce mowing speed, and mow counterclockwise around trees, posts, flower beds, sprinklers, etc.
 - If the cut is uneven or the cut quality is not acceptable, inspect the condition of the blades and the deck. If these parts are OK, a deck adjustment may be required. Your authorized Honda dealer has the expertise to make any necessary adjustments.
 - Refer to page 38 for important information about mowing on sloping surfaces.

Starting the lawn tractor

Be sure the area is clear of people, pets and other obstacles before mowing.

1. Set the cutter deck height adjusting lever to the desired cutting height.

NOTE: Be sure that the anti-scalp rollers are in the correct position for the selected cutting height and terrain (see page 24).

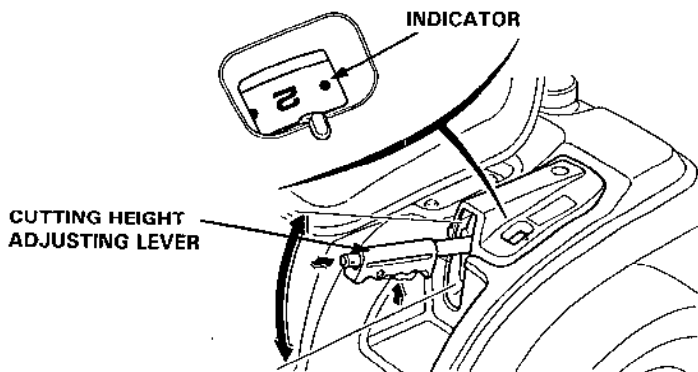

2. Move the throttle lever to the FAST position.

NOTE: For best cut quality, and performance, always mow with the throttle lever in the FAST position. Use the shift lever to select the desired mowing speed range.

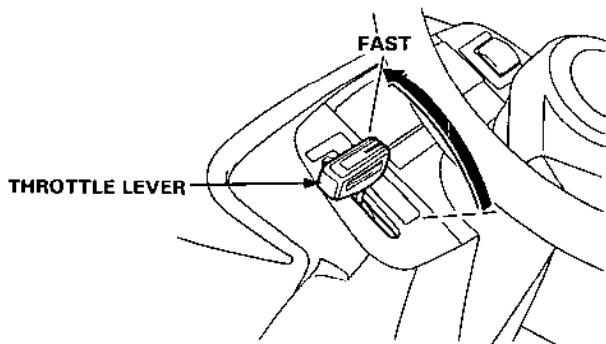

3. Move the P.T.O. lever to the ON (Engaged) position.

IMPORTANT NOTICE To avoid premature wear to the P.T.O. clutch and brake system, always engage and disengage the P.T.O. lever with a quick, smooth motion.

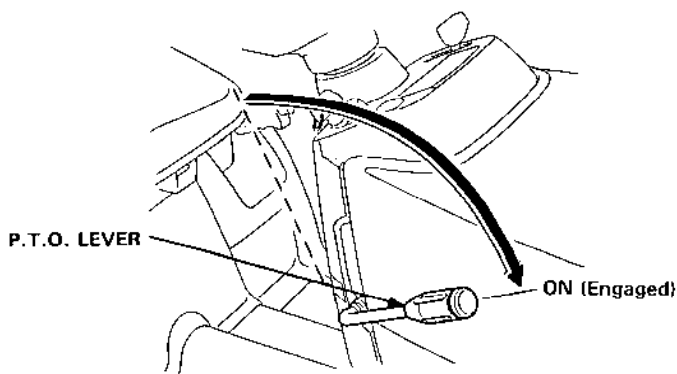

4. Move the shift lever to select the desired mowing speed position. The clutch will engage automatically in about one second.

CAUTION

- If clutch engagement occurs immediately or takes longer than one second, have the lawn tractor serviced by your authorized Honda dealer.
- When operating the lawn tractor on rough or uneven terrain, select a mowing speed that will give you the proper ground speed while the engine is running at full throttle.

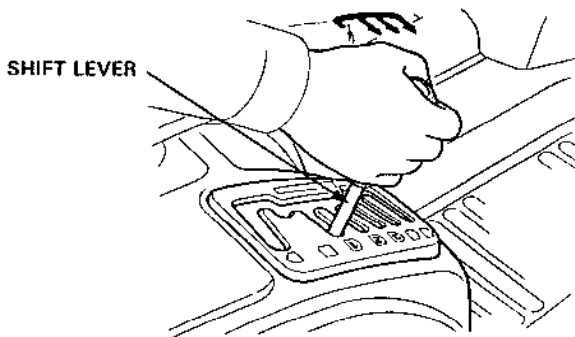

Cutting patterns

These cutting patterns are only recommended for a flat, level lawn surface.

- **In a small area**

First make 2 or 3 turns in a clockwise direction; then turn around and continue cutting in the reverse direction.

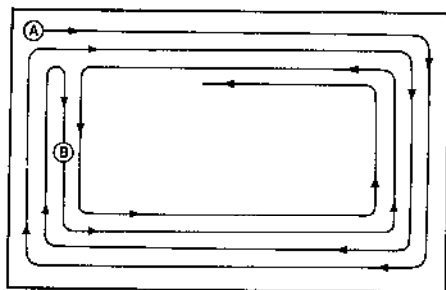

- **In a large area**

The first round of cuts is the key to making a neat finish. First, make 2 or 3 turns in a clockwise direction. As you reach the center of the area, turn to the right and continue cutting in the reverse direction until you have finished the upper half of the area. Cut the grass in the remaining half in a counterclockwise direction.

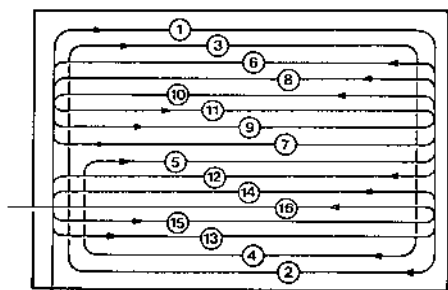

- **Mowing unsquare areas**

If your mowing area is not square or four-sided, divide the area into several blocks so you can mow in a neat mowing pattern.

- **Overlapping on straightaways**

Be sure that each mowing lane overlaps sufficiently. The recommended overlap width is between 10–15 cm (4–6 in), or approximately the width of one of the mower's front tires.

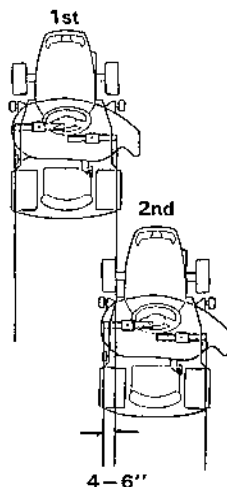

- **Overlapping in curves and turns**

When cutting in curves and turns, shift the transmission to 1st gear and be sure to overlap width is between 15–20 cm (6–8 in), or approximately the width of one of the mowers front tires.

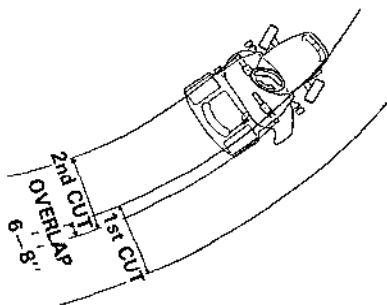

Operation on hills

This lawn tractor is intended for use on relatively flat terrain. Operating on slopes exceeding in 10° (17% grade) could cause the tractor to tip over.

Maximum safe operating angle

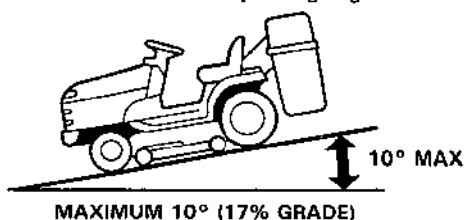

NOTE: If you feel that you cannot accurately judge the angle of a grade, we suggest that you obtain an inclinometer. These slope gauges are available at many hardware stores.

Mowing on hills

- Reduce speed and exercise extreme caution.
- Always drive up and down the face of the grade. Never turn around on or drive across the face of the grade; this may cause the tractor to tip over.
- Empty grass bags when they are half full. The weight of full bags could cause the tractor to tip over.

Stopping on hills

If possible, avoid stopping while driving uphill. If it is necessary to stop on a hill, follow the procedures below:

1. Push the brake pedal to the floor; the clutch will disengage.
2. Shift the transmission to neutral.
3. Move the P.T.O. lever to the OFF (disengaged) position.
4. Set the parking brake.

Starting on hills

It is important to follow the uphill starting procedure carefully to avoid tipping the lawn tractor over.

1. Set the parking brake and start the engine.
2. Apply pressure to the brake pedal.
3. Move the throttle lever to mid range, and shift the transmission to 1st gear position. (The warning buzzer should sound until the parking brake is released).
4. Release the brake pedal.
5. Wait until the clutch engages, then release the parking brake.

▲WARNING Abruptly applying the brake pedal while the tractor is rolling backwards down a slope may cause the tractor to tip over.

Stopping the engine

- **In an emergency:**

1. Turn the engine switch OFF and depress the foot brake.
2. Set the parking brake.

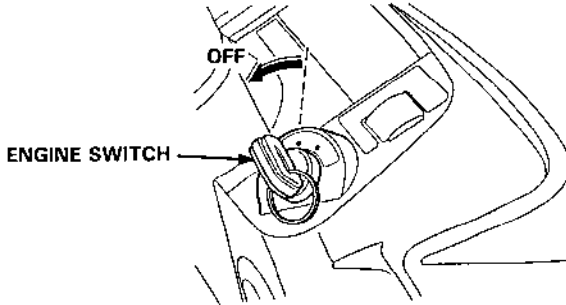

- **In normal use:**

1. Move the P.T.O. lever to OFF (Disengaged).

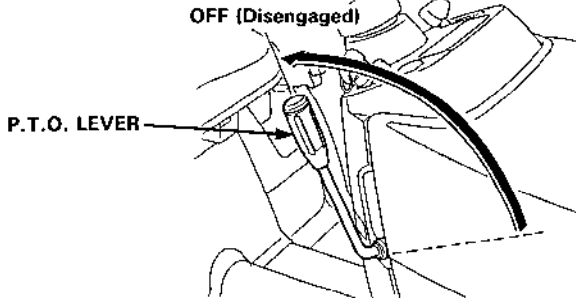

2. Move the shift lever to the Neutral position.
3. Set the parking brake.
4. Turn the engine switch OFF.
5. Remove the engine switch key.

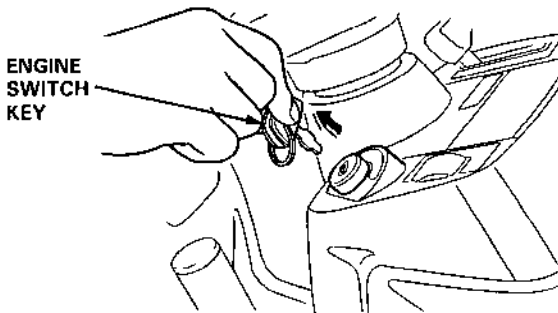

High Altitude Operation

At high altitude, the standard carburetor air-fuel mixture will be too rich. Performance will decrease, and fuel consumption will increase. A very rich fuel mixture may also foul the spark plugs and cause hard starting.

High altitude performance can be improved by installing a smaller diameter main fuel jet in the carburetor and readjusting the pilot screw. If you always operate the engine at altitudes higher than 6,000 feet above sea level, have an authorized Honda lawn tractor dealer perform this carburetor modification.

Even with carburetor modification, engine horsepower will decrease about 3.5% for each 1,000 feet increase in altitude. The effect of altitude on horsepower will be greater than this if no carburetor modification is made.

IMPORTANT NOTICE Once a carburetor is jetted for high altitude use, operation at lower altitudes without rejetting may result in reduced performance, overheating, and serious engine damage.

It is especially important to rejet a carburetor when going from a higher altitude to a lower one. At lower altitudes, the air/fuel mixture may become excessively lean.

6. TRANSPORTING

Transporting

⚠ WARNING The engine and exhaust system become hot during operation and remain hot for a while after stopping. Contact with hot engine components or the exhaust system can cause burns and can ignite some materials.

Avoid touching the engine or exhaust system for at least 15 minutes after the engine has stopped. Allow the engine to cool before transporting the lawn tractor.

IMPORTANT NOTICE Towing the lawn tractor behind another vehicle or using it to push another vehicle can damage the lawn tractor.

Transport the lawn tractor on a flat, level trailer or in a pickup truck. To avoid gasoline spillage, keep the lawn tractor level while transporting.

⚠ WARNING Gasoline is extremely flammable, and gasoline vapor can explode, causing injury or death.

Set the parking brake, and then tie the tractor down securely.

Tie-down hooks should be on or near the floor. Use the tie-down points shown below.

IMPORTANT NOTICE To avoid damaging the tie-rods, be careful not to put the ropes around or near them when securing the front end.

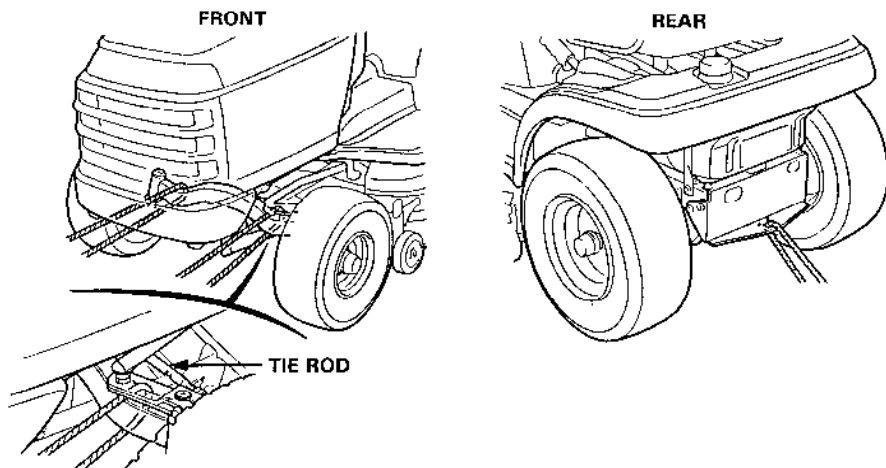

Towing

Trailer safety

▲ WARNING

- **Avoid sudden starts and stops while towing.** The additional weight of the trailer or attachment could cause loss of control resulting in an accident.
- **Never allow anyone to ride in the trailer.**
- **Failure to use the proper type of trailer hitch could cause the tractor to overturn resulting in severe personal injury.**
- **The weight of a trailer increases stopping distances; use extra care, especially when operating on a slope.**
- **To avoid loss of control, use extra care when towing a trailer on a wet or rough surface.**
- **This tractor is intended for use on relatively flat terrain.**
Towing a trailer on a slopes exceeding 10° (17% grade) could cause the tractor and/or the trailer to tip over.
- **Use rear wheel weights when towing a trailer on grades.** Failure to use wheel weights could reduce braking power.
- **Reduce speed when towing on slopes.** Use the MOWING speed range (1st, 2nd or 3rd gear) only.
- **Avoid sharp turns when towing a trailer on a slope.** If the trailer's load is unbalanced, the trailer and/or tractor may overturn.
- **Secure the load before driving.** If the load shifts while driving, steering and/or braking can be affected, and in some cases the trailer may jack knife.

Optional trailer hitch

An optional draw bar hitch is available from your authorized Honda lawn tractor dealer. This hitch is specifically designed for your lawn tractor. Using a ball-type hitch or attaching a trailer directly to the tractor's hitch plate could damage the tractor or make it unstable.

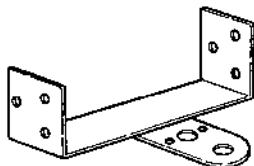

OPTIONAL TRAILER HITCH

Maximum towing weight:



On flat surface 227 kg (500 lbs)
On grade (10° or less) 127 kg (280 lbs)

▲ WARNING Exceeding the maximum towing weight could lead to a loss of control and cause an accident resulting in severe personal injury.

Maximum tongue weight 20 ± 9 kg (44 ± 20 lbs)

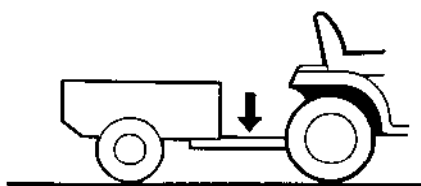

NOTE: Tongue weight is the downward weight that the trailer exerts on the trailer hitch.

▲ WARNING Improper tongue weight can affect steering and braking control. Verify tongue weight before driving.

7. MAINTENANCE

Periodic maintenance and adjustment are necessary to keep the lawn tractor in good operating condition. Service and inspect according to the MAINTENANCE SCHEDULE.

▲ WARNING

- To avoid carbon monoxide poisoning, shut off the engine before performing any maintenance. If you run the engine in an area that is confined, or even partially enclosed, the air you breathe can contain a dangerous amount of exhaust gas. If the engine must be run for any reason, be sure the area is well-ventilated.
- To avoid serious burns, allow the engine to cool before performing maintenance.
- Shut the engine off and set the parking brake before performing any maintenance.

To prevent accidental start-up, remove the engine switch key and disconnect the spark plug cap.

The lawn tractor should be serviced by an authorized HONDA lawn tractor dealer unless the owner has proper tools and service data and is mechanically qualified.

IMPORTANT NOTICE Use only genuine Honda parts or their equivalent for maintenance or repair. Replacement parts which are not of equivalent quality may damage your lawn tractor.

ENGINE SWITCH KEY

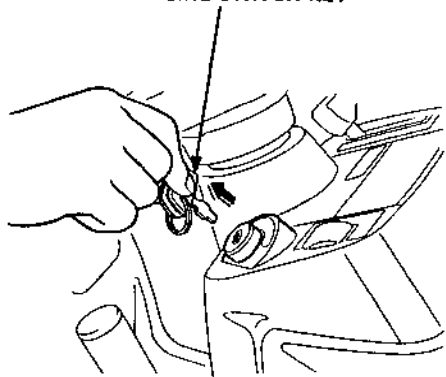

SPARK PLUG CAP

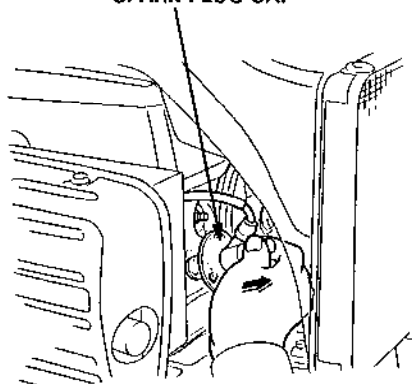

Maintenance schedule

REGULAR SERVICE PERIOD		EACH USE	FIRST 3 MONTHS OR 20 HRS (3)	EVERY 6 MONTHS OR 50 HRS (3)	EVERY YEAR OR 100 HRS (3)	EVERY 3 YEARS OR 300 HRS (3)	EVERY 5 YEARS OR 500 HRS (3)
ITEM	Perform at every indicated period or operating hour interval, whichever comes first.						
Engine oil	Check level	○					
	Change		○		○		
Air cleaner	Check	○					
	Clean			○(1)			
Seat switch operation	Check	○			○(2)		
Dust screen	Clean	○					
Parking brake indicator lamp and buzzer operation	Check	○		○(2)			
Battery electrolyte	Check level	○					
	Check level and gravity			○(2)			
Tire pressure	Check	○					
Deck belt	Check	○					
Blade belt	Check	○					
Grass bag (optional parts)	Clean	○					
Foot brake	Check	○					
Blade bolt tightness	Check		○(2)	○(2)			
Blade condition	Check	○					
Shift lever	Check-Adjust		○(2)	○(2)			
Brake (fastener tightness)	Check		○(2)		○(2)		
Parking brake	Check			○(2)			
Spark plug	Check-Clean				○		
Spark arrester (optional part)	Clean				○		
Transmission oil	Check level				○(2)		
	Change						○(4)
Fuel tank	Clean					○(2)	
Fuel filter (Replace if necessary)	Check				○(2)		
P.T.O. clutch cable	Check-Adjust		○(2)		○(2)		
P.T.O. clutch condition	Check				○(2)		
Primary drive belt	Check	○				○(2)	
Throttle cable	Check-Adjust				○(2)		
Front axle	Grease			○(2)			
Fuel line (Replace if necessary)	Check		Every 2 years				
Valve clearance	Check-Adjust					○(2)	

- NOTE: (1) Service the air cleaner more frequently when used in dusty areas.
 (2) These items should be serviced by an authorized Honda dealer, unless the owner has proper tools and is mechanically proficient. See the Honda Shop Manual.
 (3) For professional commercial use, log hours of operation to determine proper maintenance intervals.
 (4) Must be serviced by an authorized Honda dealer.

Engine Oil Change

Drain the oil while the engine is warm to assure rapid and complete draining.

CAUTION Used motor oil may cause skin cancer if repeatedly left in contact with the skin for prolonged periods.

Although this is unlikely, unless you handle used oil on a daily basis, it is still advisable to thoroughly wash your hands with soap and water as soon as possible after handling used oil.

1. Open the engine hood.
2. Remove the oil filler cap and drain bolt, and drain the oil into a suitable container.

NOTE: To remove the drain bolt, turn the steering wheel to the extreme left and remove the bolt from the right side.

3. Retighten the drain plug securely.
4. Refill to the upper level mark on the dipstick with the recommended oil (see page 16). Tighten the oil filler cap securely.

OIL CAPACITY: 1.1 l (1.2 US qt)

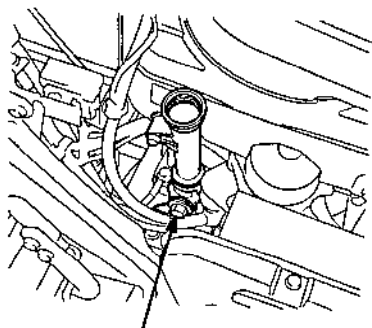

OIL DRAIN BOLT

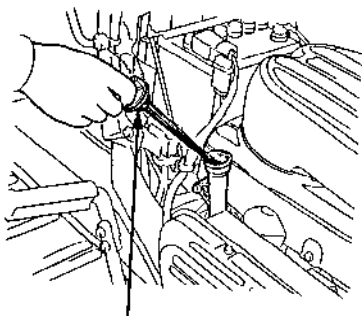

OIL FILLER CAP

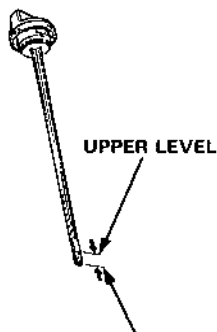

UPPER LEVEL

LOWER LEVEL

NOTE: Please dispose of used motor oil in a manner that doesn't harm the environment. We suggest you take it in a sealed container to your local service station for reclamation. Do not throw it in the trash or pour it on the ground or down a drain.

Air Cleaner Service

A dirty air cleaner will restrict air flow to the carburetor. If you operate the lawn tractor in very dusty areas, clean the air cleaner more often than specified in the MAINTENANCE SCHEDULE.

Operating the engine without the air cleaner will cause rapid engine wear.

1. Open the engine hood.
2. Remove the wing nut and air cleaner cover. Remove the wing nut and air cleaner elements.
3. Foam element: Clean in warm, soapy water, rinse, and dry thoroughly. Or, clean in nonflammable solvent and dry. Dip the element in clean engine oil, then squeeze out all excess oil. The engine will smoke when started if too much oil is left in the foam.

⚠ WARNING Using gasoline or flammable solvent to clean the filter element can cause a fire or explosion. Use only soapy water or nonflammable solvent.

4. Paper element: Tap the element several times on a hard surface to remove loose dirt, or blow low pressure (30 psi or less) compressed air through the filter from the inside. Do not try to brush off dirt. Brushing will force dirt into the fibers.

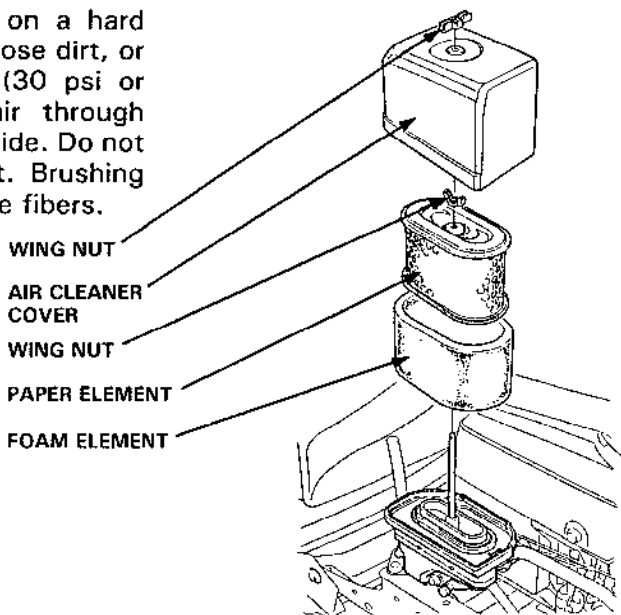

Spark Plug Service

Recommended spark plug: BPR5ES (NGK), W16EPR-U (ND)

⚠ WARNING Touching a hot engine or exhaust system can cause serious burns. Let the engine cool before performing maintenance.

IMPORTANT NOTICE Spark plugs of the wrong heat range can cause engine damage.

For best performance, the spark plug must be properly gapped and free of deposits.

1. Open the engine hood and remove the spark plug cap.
2. Clean any dirt from around the spark plug base.
3. Use a spark plug wrench to remove the spark plug.

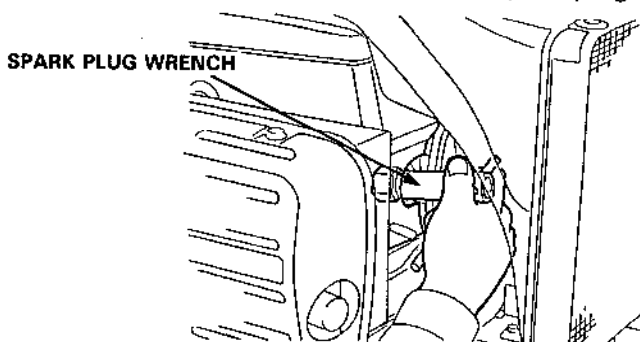

4. Visually inspect the spark plug. Discard the spark plug if there is apparent wear, or if the insulator is cracked or chipped. Clean the spark plug with a wire brush if it is to be reused.
5. Measure the plug gap with a feeler gauge.
The gap should be 0.7–0.8 mm (0.028–0.031 in). Correct as necessary by carefully bending the side electrode.

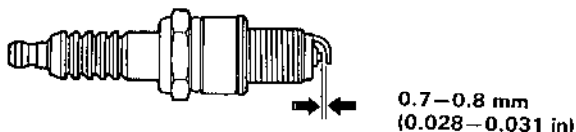

6. Install the spark plug carefully, by hand, to avoid cross-threading.

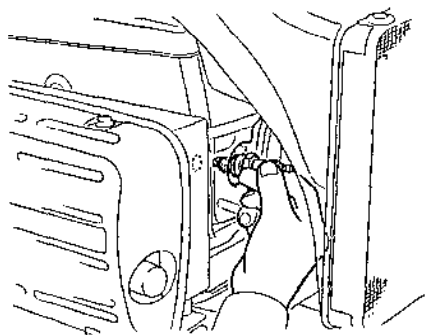

7. After the spark plug is seated, tighten with a spark plug wrench to compress the washer.

IMPORTANT NOTICE A loose spark plug can get hot enough to damage the engine. Overtightening may damage the threads.

NOTE: If installing a new spark plug, tighten $1/2$ turn after the spark plug seats to compress the washer. If reinstalling a used spark plug, tighten $1/8 - 1/4$ turn after the spark plug seats to compress the washer.

SPARK PLUG WRENCH

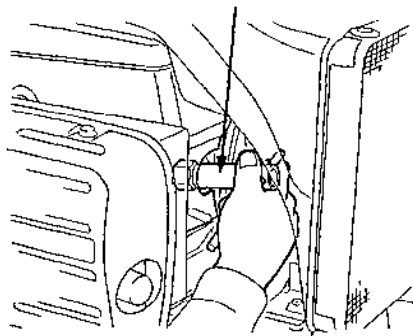

Battery Service

■ Refilling battery fluid

If the lawn tractor is operated with insufficient battery electrolyte, sulfation and battery plate damage will occur.

If rapid loss of electrolyte is experienced, or if your battery seems to be weak, causing slow starting or other electrical problems, see your authorized Honda dealer.

Open the engine hood and check the electrolyte level in each battery cell. Fill the battery with distilled water to the upper level line. Never overfill the battery.

▲ WARNING Batteries produce explosive gases. An explosion can cause serious injury or blindness. Provide adequate ventilation when charging.

- **CHEMICAL HAZARD:** Battery electrolyte contains sulfuric acid. Contact with eyes or skin, even through clothing, may cause severe burns. Wear a faceshield and protective clothing.
 - Keep flames and sparks away, and do not smoke in the area.
- ANTIDOTE:** If electrolyte gets into your eyes, flush thoroughly with warm water for at least 15 minutes and call a physician immediately.
- **POISON:** Electrolyte is poison.

ANTIDOTE

— External: Flush thoroughly with water.

— Internal: Drink large quantities of water or milk.

Follow with milk of magnesia or vegetable oil, and call a physician immediately.

- **KEEP OUT OF REACH OF CHILDREN.**

NOTE: Use distilled water in the battery.

- Tap water will shorten the service life of the battery.
- Overfilling may cause electrolyte overflow and corrosion. Wash off any spilled electrolyte immediately.

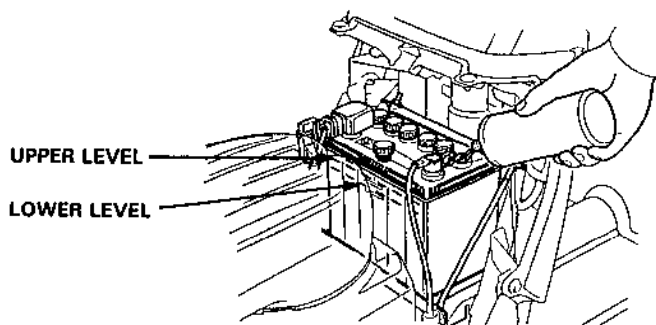

■ Battery cleaning

If the battery terminals are contaminated or corroded, remove the battery and clean the terminals.

1. Disconnect the battery cable at the battery negative (-) terminal.
2. Remove battery set plate.
3. Disconnect at the battery positive (+) terminal.

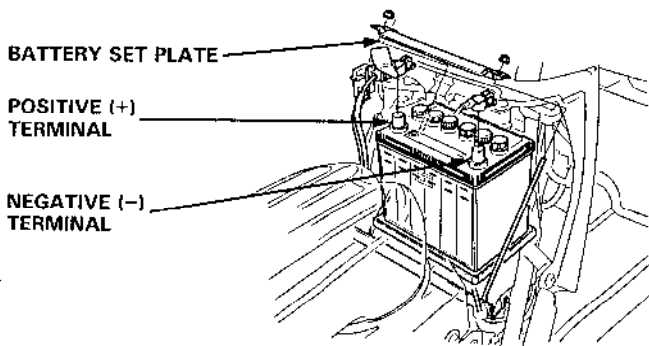

4. Remove the battery and clean the battery terminals and battery cable terminals with a wire brush or sand paper.
Clean the battery with a solution of baking soda and warm water, taking care not to get the solution or water in the battery cells. Dry the battery thoroughly.
5. Connect the battery positive (+) cable to the battery positive (+) terminal.
6. Reinstall the battery set plate.
7. Connect the battery negative (-) cable to the battery negative (-) terminal. Tighten the bolts and nuts securely.
8. Coat the battery terminals with grease.

▲ CAUTION When disconnecting the battery cable, be sure to disconnect at the battery negative (-) terminal first. To connect, connect at the positive (+) terminal first, then at the negative (-) terminal. Never dis/connect the battery cable in the reverse order, or it causes a short circuit when a tool contacts the terminals.

Wheel removal

Do not attempt to remove or replace a tire unless you have the equipment and knowledge to do so properly.

1. Block the wheels securely.
2. Remove the wheel cap, and then remove the cotter pin and loosen the 19 mm nut one turn.
3. Jack up the front or rear of the lawn tractor, and place safety stands under the frame. Remove the 19 mm nut, washer, and wheel.
4. Rear wheel only; apply a thin coat of grease to the rear axle (splined position) before installing the rear wheel.
5. Install the wheel in the reverse order of removal.
6. Tighten the 19 mm nut to the lower specified torque.

Wheel nut torque: 5.5–6.5 kg-m (40–47 ft-lb)

7. Align the nut to the next possible cotter pin hole while tightening the nut just beyond the lower specified torque. Install a new cotter pin and bend the ends as shown.

NOTE: Do not align the cotter pin holes in a position where the wheel nut torque is less than the specified torque.

[JACK POINTS]

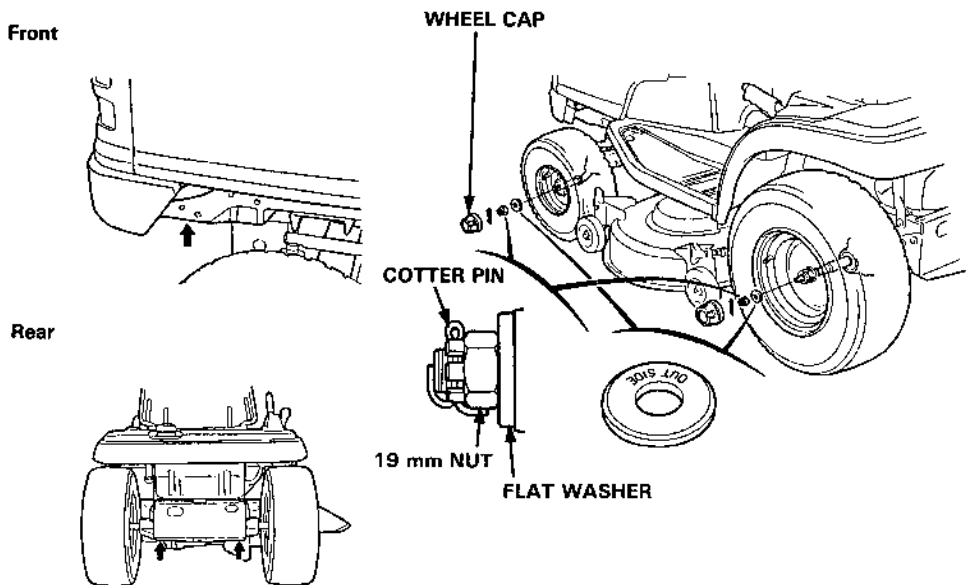

Cutter deck removal

▲WARNING Never attempt to remove the cutter deck while the engine is running. Remove the key from the engine switch and disconnect the spark plug cap to prevent accidental start up.

1. Lower the cutter deck and loosen the belt tension adjusting knob (page 23).
2. Remove the belt from the engine pulley.

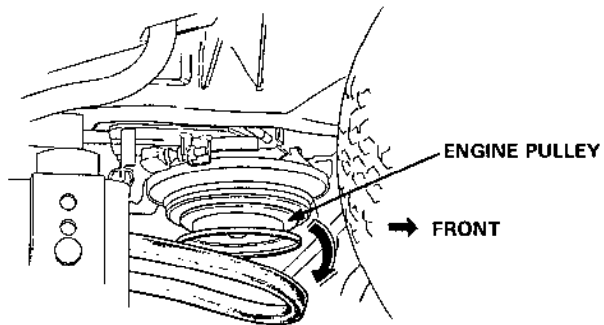

3. Remove the belt from the deck driven pulley.

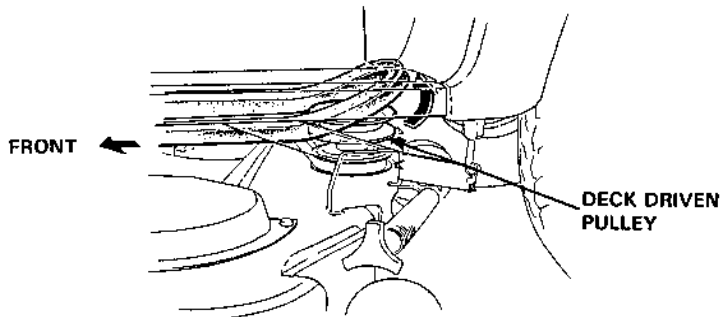

3. Remove the six yellow-colored lock pins (three on each side), and then remove the front deck links.

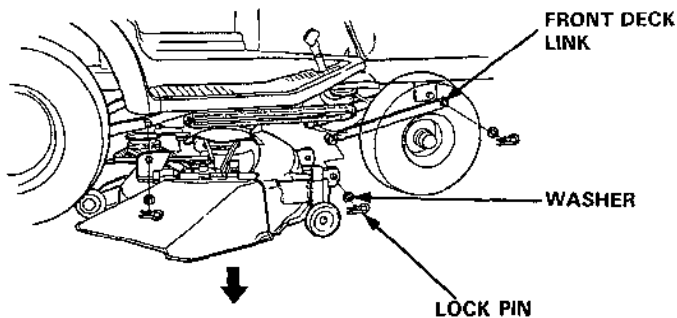

4. Raise the deck height adjusting lever as far as it will go.
5. Turn the steering wheel all the way to the left, and carefully remove the deck from the right side of the tractor.

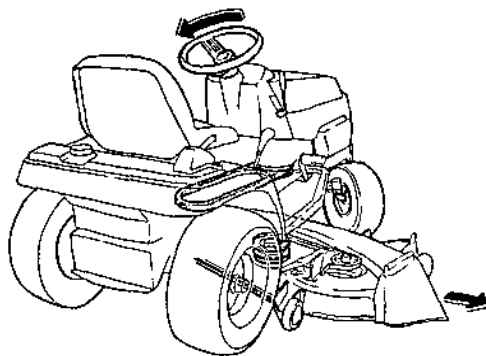

6. Installation is the reverse of disassembly.

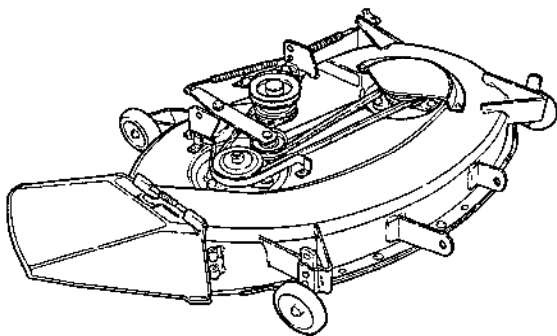
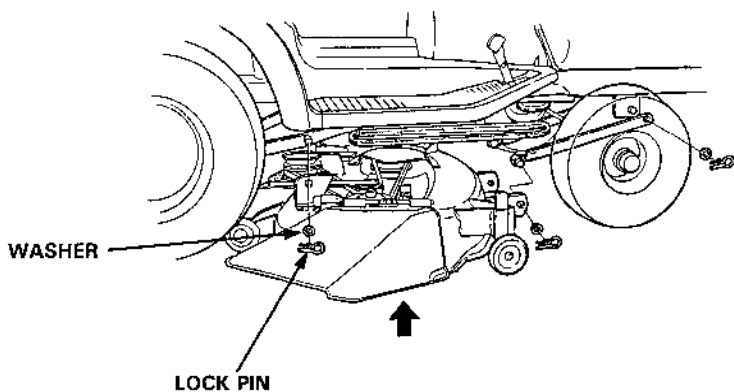

NOTE: After installation, readjust drive belt tension.

Cutter deck drive belt replacement

Shut the engine off and set the parking brake before performing any maintenance.

To prevent accidental start-up, remove the engine switch key and disconnect the spark plug cap.

CAUTION

- Wear heavy gloves to protect your hands when replacing drive belts or when working with the cutter blades.
- If the tractor has been running, the engine, muffler and radiator will be very hot. Allow them to cool before proceeding.

1. Lower the cutter deck.
2. Loosen the belt tension adjusting knob.
3. Remove the belt from the engine pulley.

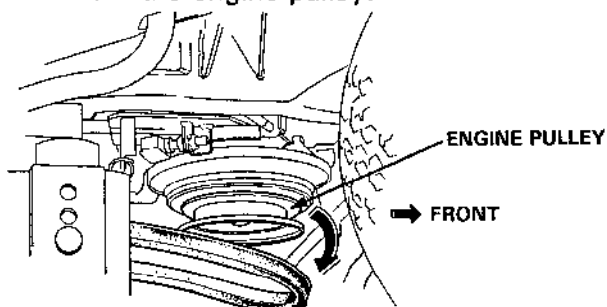

4. Remove the belt from the cutter deck driven pulley.
5. Pull out the drive belt.

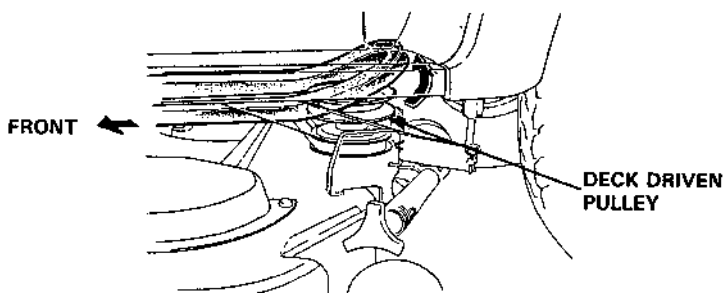

6. Installation sequence is essentially the reverse order of removal. See page 23 for belt tension adjustment.

- After installing the belt and adjusting the belt tension, start the engine and shift the P.T.O. lever into ON and OFF to be sure that it operates properly.

Blade belt replacement

1. Remove the cutter deck (see pages 53 and 54).
2. Remove the nuts and then remove the belt stopper and pulley cover.
3. Pull the belt off pulley A, hold the belt securely and slowly release the tensioner pulley.

CAUTION Wear heavy gloves to protect your hands when replacing the blade belt, and don't put your hands between the pulleys.

4. Remove the belt from the other pulleys, and replace the belt.

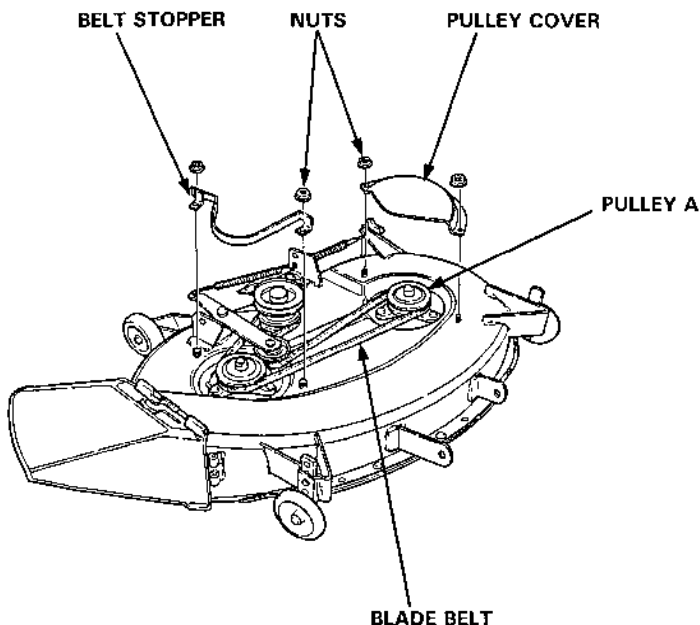

Blade bolt tightness/Blade replacement

■ Blade bolt tightness

1. Remove the cutter deck from the lawn tractor (see pages 53 and 54).
2. Turn the cutter deck upside down.
3. Clean dirt and grass from the blade and the inside of the cutter deck.
4. While wearing heavy gloves, hold the blade firmly, and use a torque wrench to check that the blade bolt is properly tightened.

Blade bolt torque:

6.0 kg-m (44 ft-lb)

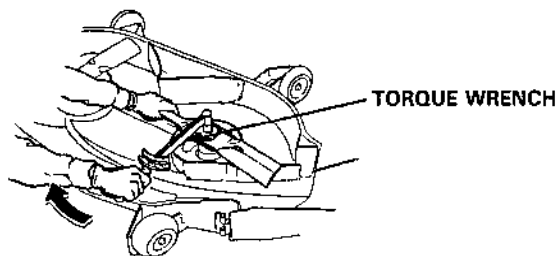

■ Blade removal

1. Hold the blade firmly, and remove the blade bolt and the washer.
2. Remove the blade and blade holder.

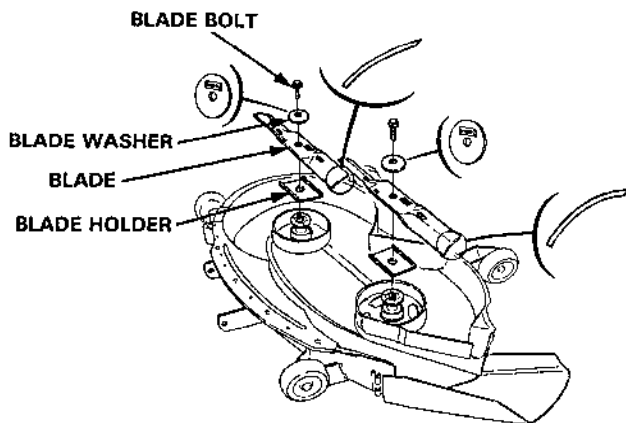

■ Blade installation

IMPORTANT NOTICE Use a genuine Honda replacement blade or equivalent.

1. Clean dirt and grass from the blade, blade holder, and the inside of the cutter deck.
2. Install the blade holder, blade, washer, and blade bolts.

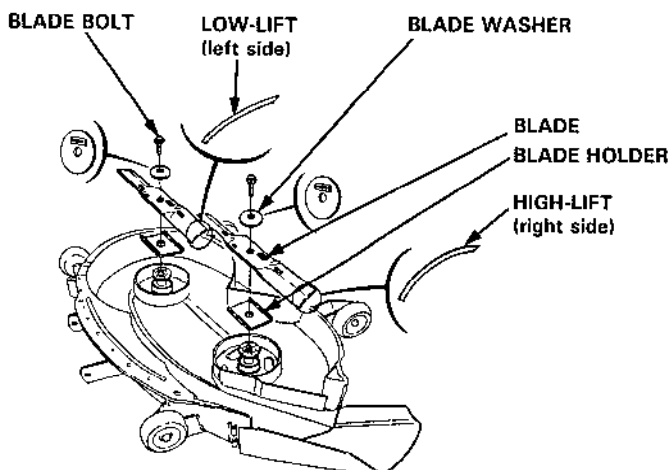

NOTE:

- Right and left blades are not interchangeable. Be sure to install the high-lift blade on the right (discharge side) and the low-lift blade on the left side, as shown.
 - Be sure the blade is properly aligned with the blade holder before tightening the blade bolt. Do not allow the blade to overlap the edge of the holder.
 - Install the blades so that the lift, the curved section of the blade, points toward the cutter deck as shown.
 - Install the washer with the side marked "INSIDE" facing the blade.
 - The blade bolt and washer are specially designed for this application and must not be replaced with any other bolt or washer.
3. Hold the blade firmly, and tighten the blade bolt to a torque value of 6.0 kg-m (44 ft-lb).

Spark arrester maintenance (optional part)

You can purchase an optional, U.S.D.A. qualified spark arrester for this product from your authorized Honda Power Equipment dealer. Spark arresters are required in some areas; check local laws and regulations before operating this Honda product.

▲ WARNING The muffler becomes very hot during operation and remains hot for a while after the engine stops. Be careful not to touch the muffler while it is hot. Allow it to cool before proceeding.

The spark arrester must be serviced every 100 hours to maintain its efficiency.

1. Remove the four 6 mm bolts and remove the muffler protector.
2. Remove the two 5 mm screws from the exhaust pipe tip. Remove the exhaust pipe tip and spark arrester (be careful not to damage the spark arrester screen).
3. Use a wire brush to remove carbon deposits from the spark arrester screen.

NOTE: Inspect the spark arrester screen for holes or tears. Replace it if it is damaged.

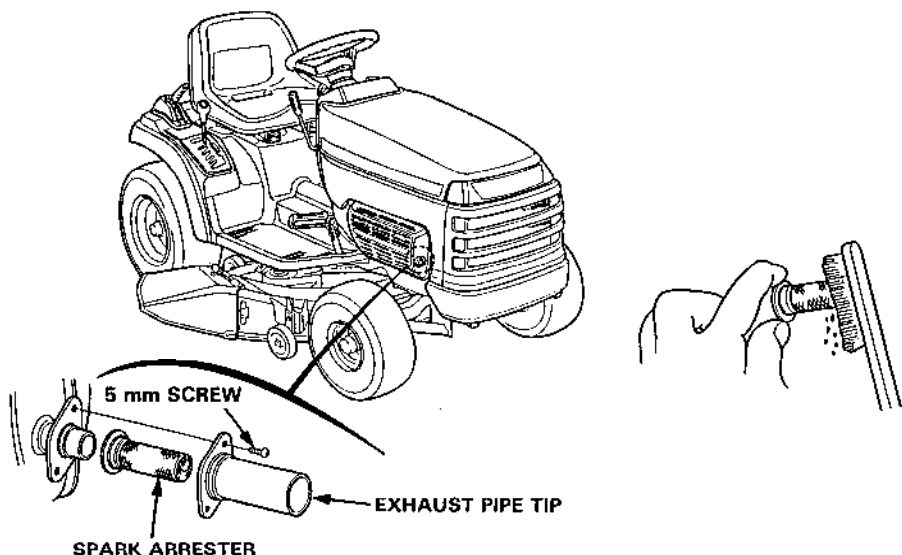

Fuse replacement

The 20 A main fuse is located near the battery on the positive (+) terminal. When frequent fuse failure occurs, it usually indicates a short circuit or an overload in the electrical system. See your authorized Honda dealer for repair.

To replace a fuse, pull the old fuse out of the clips with your finger. Push a new fuse into the clips.

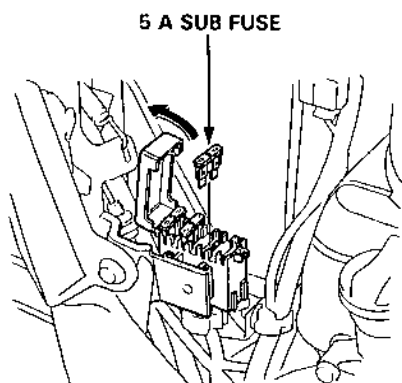
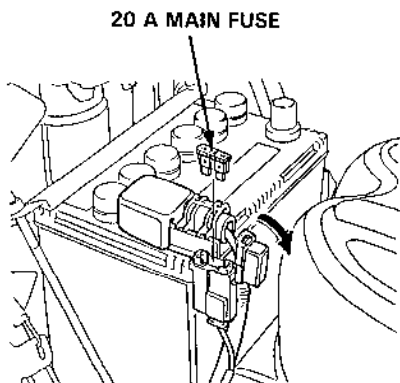

⚠ WARNING Never use a fuse with a different rating from that specified. Serious damage to the electrical system or a fire may result.

Turn the engine switch OFF and remove the key. Disconnect the battery cable at the battery negative (-) terminal before checking or replacing fuses to prevent accidental short-circuiting.

Fuel filter

Remove the fuel filter by pulling it out of its clip under the fuel tank and visually inspect it through the opening in the hitch plate. Replace the filter if it is contaminated with dirt or water.

NOTE: Drain the fuel tank before disconnecting the fuel lines from the fuel filter (see page 63).

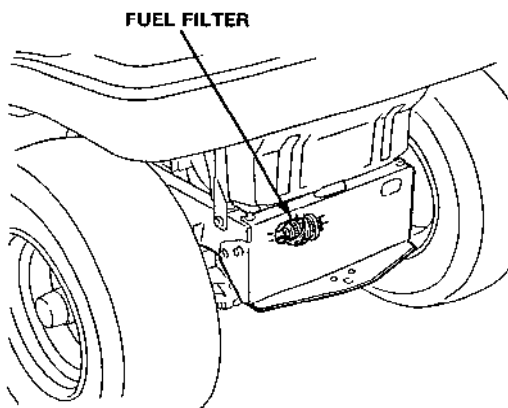

Transmission oil

1. Park the tractor on level ground.
2. Remove the oil filler cap and make sure that the oil level is up to the lower edge of the oil filler hole.
3. If the oil level is low, add the recommended oil until it reaches the lower edge.

Recommended oil: SAE 10W - 30 engine oil (see page 16)

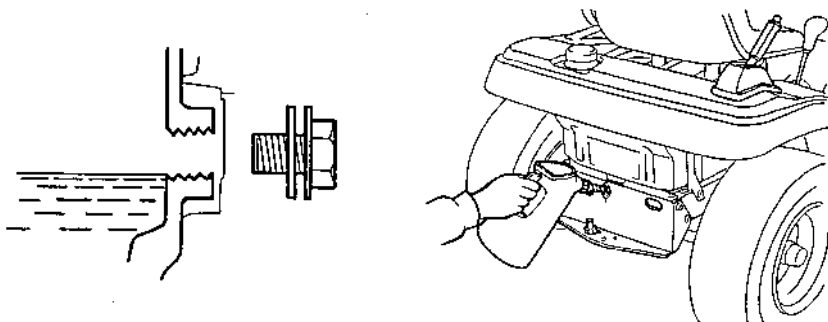

8. LONG TERM STORAGE

Preparation for storage

The engine becomes very hot during operation and remains hot for a while after stopping. Allow the engine to cool before storing.

▲WARNING Contact with a hot engine or exhaust system can cause serious burns or fires. Let the engine cool before storing.

The following steps should be taken to protect the lawn tractor whenever it will be stored for longer than 30 days.

1. Pump all gasoline from the fuel tank into an approved gasoline container.

▲WARNING Gasoline is extremely flammable, and gasoline vapor can explode, causing serious injury or death. Use extreme care when handling gasoline. Keep flames and sparks away, and do not smoke in the area.

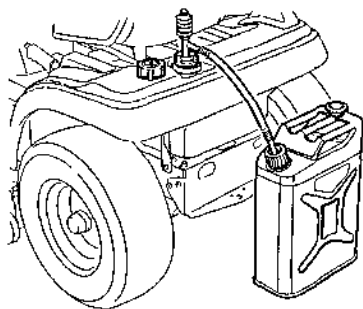

- Loosen the carburetor drain screw, and drain the fuel into an approved gasoline container. After draining, tighten the drain screw securely.

NOTE: If gasoline is not drained before storage, fuel system damage may result.

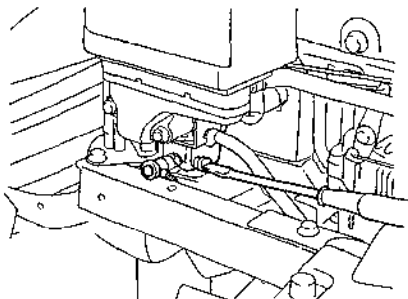

2. Change the engine oil (see page 46).

NOTE: If the lawn tractor will be stored for longer than 3 months, remove the spark plug and pour three tablespoons (approximately 1 oz.) of clean motor oil into the cylinder.

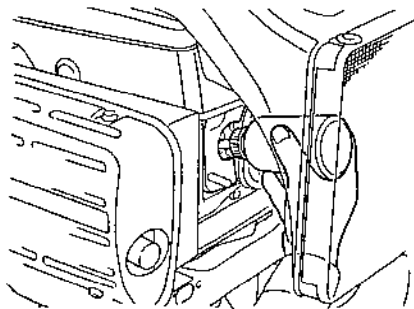

Place the P.T.O. (Power Take-off) lever in the ON position. Turn the front clutch several rotations by hand, then return the P.T.O. lever to the OFF position. Reinstall the spark plug.

CAUTION Be sure to wear heavy-duty gloves when turning the front clutch. If the lawn tractor has been running, the engine will be very hot. Allow it to cool before proceeding.

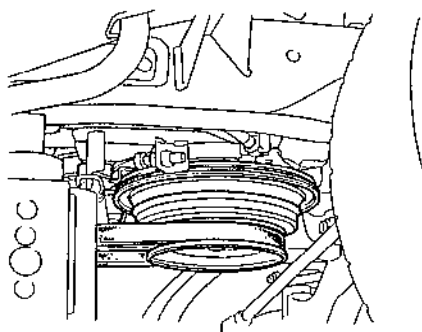

3. Remove the battery and store in a cool, dry place. Recharge it once a month.

-
4. If equipped with the optional grass catcher, be sure to empty and clean the bags before storage.
 5. Remove the cutter deck (see pages 53 and 54).
 6. Turn the cutter deck upside down. Clean the underside of the deck with water, and dry thoroughly.
 7. For longer service and greater efficiency, keep the underside of the mower housing clean and free of accumulated grass clippings by washing it down with a hose after use and/or cleaning it with a wire brush and scraper. Remove any rust and apply a rust-resistant paint. Cleaning and rust prevention are especially important before seasonal storage.
 8. Reinstall the cutter deck by reversing the removal procedure.
 9. Store the lawn tractor on a level surface in a dry, dust-free area with the parking brake lever set.
 10. Cover the lawn tractor to keep out dust.
 11. Check tire air pressure regularly during storage and inflate if necessary.

Removal from storage

1. Check the battery electrolyte level (see page 21). Fully charge the battery, and install it in the tractor.
2. Remove the spark plug and check that it is clean and properly gapped (see page 48).
Turn the engine a few revolutions by hand without the spark plug.
3. Thread the spark plug in as far as possible by hand, then tighten it 1/8 to 1/4 turn further with the plug wrench.
4. Check the engine oil level (see page 16).
5. Fill the fuel tank, and start the engine by following the starting instructions (see page 29).

NOTE: If the cylinder was coated with oil, the engine will smoke at start up; this is normal.

9. TROUBLESHOOTING

Engine fails to start

1. No fuel. —————> Add fuel.
2. Shift lever in gear. —————> Position shift lever in NEUTRAL.
3. P.T.O. lever engaged. —————> P.T.O. lever in DISENGAGE.
4. Spark plug faulty or —————> Regap plug or replace (see pages 48
improperly gapped. —————> and 49).
5. Spark plug wire loose —————> Check spark plug wire.
or disconnected.
6. Fuel not reaching —————> See your authorized Honda dealer.
carburetor.
7. Discharged battery or —————> Charge battery or retighten terminal.
loose terminal. —————> (see page 51).
8. Blown fuse —————> Replace (see page 61).

Lawn tractor does not move or drives slowly with the shift lever set in the transport range.

1. Lawn tractor does not —————> See your authorized Honda dealer.
drive or drives slowly.

Engine loses power

1. Dirty air cleaner elements. —————> Clean or replace elements (see page
47).
2. Spark plug faulty or —————> Regap plug or replace. (see page 48).
improperly gapped.
3. Engine overloaded. —————> Shift to lower speed.

Engine overheats

1. Dust screen plugged. —————> Clean screen (see page 15).
2. Engine overloaded. —————> Shift to lower speed.
3. Low engine oil level. —————> Fill with recommended oil (see page
16).
4. Spark plug improperly —————> Regap plug or replace.
gapped.

Oil consumption

1. Incorrect oil viscosity → Use specified viscosity oil. (see page 16)
2. Oil leaks → Check for oil leaks from drain bolt.
3. Worn piston ring, etc. → See your authorized Honda dealer.
4. Oil level too high → Don't overfill.

Excessive vibration

1. Loose blade or engine mounting hardware → Retighten blade bolts or engine mounting hardware.
2. Blade damaged or out of balance → Replace blade.
3. Belt damaged. → Replace belt.
4. Each pulley damaged or pulleys not aligned. → See your authorized Honda dealer.

Battery will not charge

1. Dead cell in battery. → Replace battery.
2. Loose electrical connections or broken wire. → Check connections and wires.

Parking brake warning buzzer does not operate

1. Blown fuse → Replace fuse.
2. Faulty buzzer → See your authorized Honda dealer.

Steering is too heavy

1. Insufficient tire air pressure → Correct tire air pressure. (see page 25)

Mower steers to one side

1. Incorrect steering system alignment → See your authorized Honda dealer.
2. Tire air pressure uneven. → Correct tire air pressure. (see page 25)
3. Loose fasteners of steering system → See your authorized Honda dealer.

Uneven mowing

1. Lawn tractor speed too fast → Shift to lower speed.
2. Grass accumulation inside deck. → Clean inside deck.
3. Dull blade. → Replace blade or see your authorized Honda dealer.
4. Tires improperly inflated. → Check tire pressure (see page 25).
5. Mower not level. → Check cutter deck mounting. See your authorized Honda dealer.
6. Wrong cutter deck height. → Change to proper height.
7. Chute clogged (if equipped with optional grass bag). → Empty grass bag and chute.
8. Lawn wet → Allow to dry before cutting.
9. Cutter deck set too low. → Set cutter deck higher.
10. Not overlapping cut enough to compensate for grass conditions. → See page 37.
11. Throttle setting too low. → Set to FAST.

Clogged cutter deck discharge chute.

1. Wrong blade. → Use a genuine Honda blade or equivalent.
2. Deck too low. → Raise deck and adjust deck height properly.
3. Engine overloaded. → Operate at full throttle. Use lower speed range. Set cutter deck higher than desired height for first pass, then cut to desired height on second pass.
4. Wet lawn. → Mow when lawn is dry.
5. Lawn too tall. → Set cutter deck higher than desired height for first pass, then cut to desired height on second pass.
6. Low engine rpm. → Open throttle fully.
7. Grass bags full (Optional part). → Empty grass bags.
8. Blades installed upside down. → Check blade installation (see page 58).

Blade does not rotate or stop

1. Blade belt worn or broken. —> Replace with new belt (see page 57).
2. P.T.O. lever malfunction. —> See your authorized Honda dealer.

Scalping

1. Anti-scalp rollers —> Adjust anti-scalp rollers (see page not adjusted properly. 24).
2. Cutting height too low. —> Raise cutter deck height.
3. Turning speed fast. —> Lower turning speed.
4. Uneven surface. —> Change cutting pattern.
5. Rough and uneven surface. —> Adjust with cutting height adjuster (see page 34).

Mowing load is too heavy and lowers the mower speed

1. Low engine rpm. —> Open throttle fully.
2. Mower speed too fast —> Lower mower speed.
3. Mower catches wood block, —> Remove any foreign objects. stone, etc.

10. SPECIFICATIONS

MODEL	H4013
Power products description code	MZAR
ENGINE	
Model	GXV390
Type	OHV single cylinder
Displacement	389 cm ³ (23.7 cu in)
Bore and stroke	88 x 64 mm (3.46 x 2.51 in)
Ignition timing	20 ± 2° BTDC
Ignition system	Transistorized magneto
Cooling system	Forced air
Engine oil capacity	1.1 l (1.2 US qt)
Spark plug	BPR5ES (NGK), W16EPR-U (ND)
FRAME	
Dimensions	
Length x Width x Height	1,815 x 1,270 x 1,050 mm (71.5 x 50.0 x 41.3 in)
Wheel tread	Front: 730 mm (28.7 in) Rear: 750 mm (29.5 in)
Wheel base	1,190 mm (46.9 in)
Cutting width	965 mm (38 in)
Cutting height	1, 1 ¹ / ₂ , 2, 2 ¹ / ₂ , 3, 3 ¹ / ₂ , 4 in
Dry weight	246 kg (542 lbs)
Tire size	Front: 15 x 6.00—6 Rear: 20.5 x 8.50—10
Air pressure	Front: 1.0 kg/cm ² Rear: 0.8 kg/cm ²
Transmission	Constant mesh, key slide shift type 5 forward, 1 reverse speed
Travel speed (at 3,300 rpm)	
1st	1.7 km/h (1.1 miles/h)
2nd	3.4 km/h (2.1 miles/h)
3rd	5.1 km/h (3.2 miles/h)
4th	6.4 km/h (4.0 miles/h)
5th	7.6 km/h (4.7 miles/h)
Reverse	3.6 km/h (2.2 miles/h)
Fuel tank capacity	9.0 l (2.38 US gal, 1.98 Imp gal)
Battery	12V30AH

NOTE: Specifications are subject to change without notice.

11. WIRING DIAGRAM

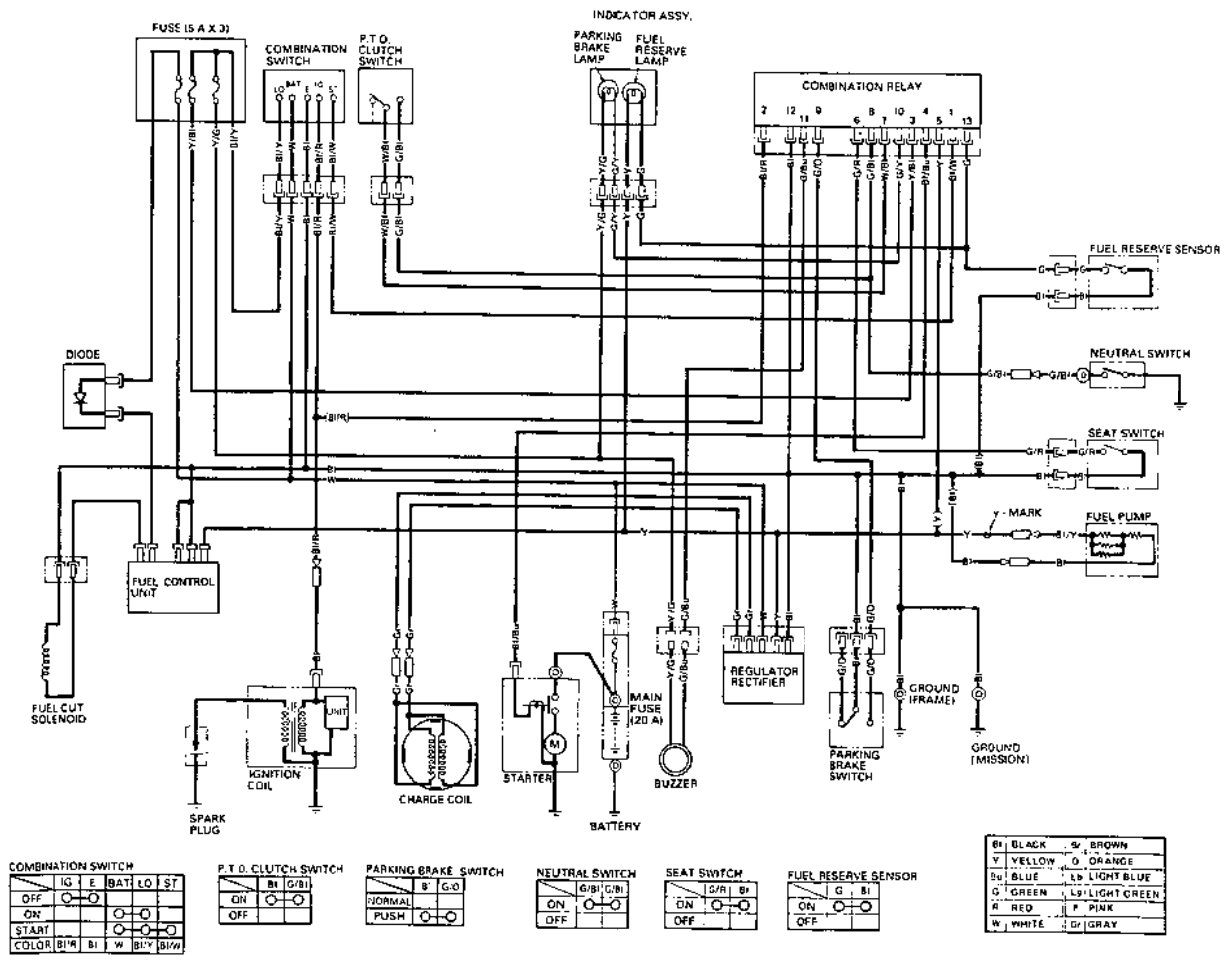

12. WARRANTY SERVICE

Owner Satisfaction

Your satisfaction and goodwill are important to your dealer and to us. All Honda warranty details are explained in the Distributor's Limited Warranty. Normally, any problems concerning the product will be handled by your dealer's service department. If you have a warranty problem that has not been handled to your satisfaction, we suggest you take the following action:

- Discuss your problem with a member of dealership management. Often complaints can be quickly resolved at that level. If the problem has already been reviewed with the Service Manager, contact the owner of the dealership or the General Manager.
- If your problem still has not been resolved to your satisfaction, contact:

American Honda Motor Co., Inc.
P.O. Box 50
Gardena, California 90247-0805
Telephone: (213) 604-2400

We will need the following information in order to assist you:

- Your name, address, and telephone number
- Product model and serial number
- Date of Purchase
- Dealer name and address
- Nature of problem

After reviewing all the facts involved, you will be advised of what action can be taken. Please bear in mind that your problem will likely be resolved at the dealership, using the dealer's facilities, equipment, and personnel, so it is very important that your initial contact be with the dealer.

Your purchase of a Honda product is greatly appreciated by both your dealer and American Honda Motor Co., Inc. We want to assist you in every way possible to assure your complete satisfaction with your purchase.

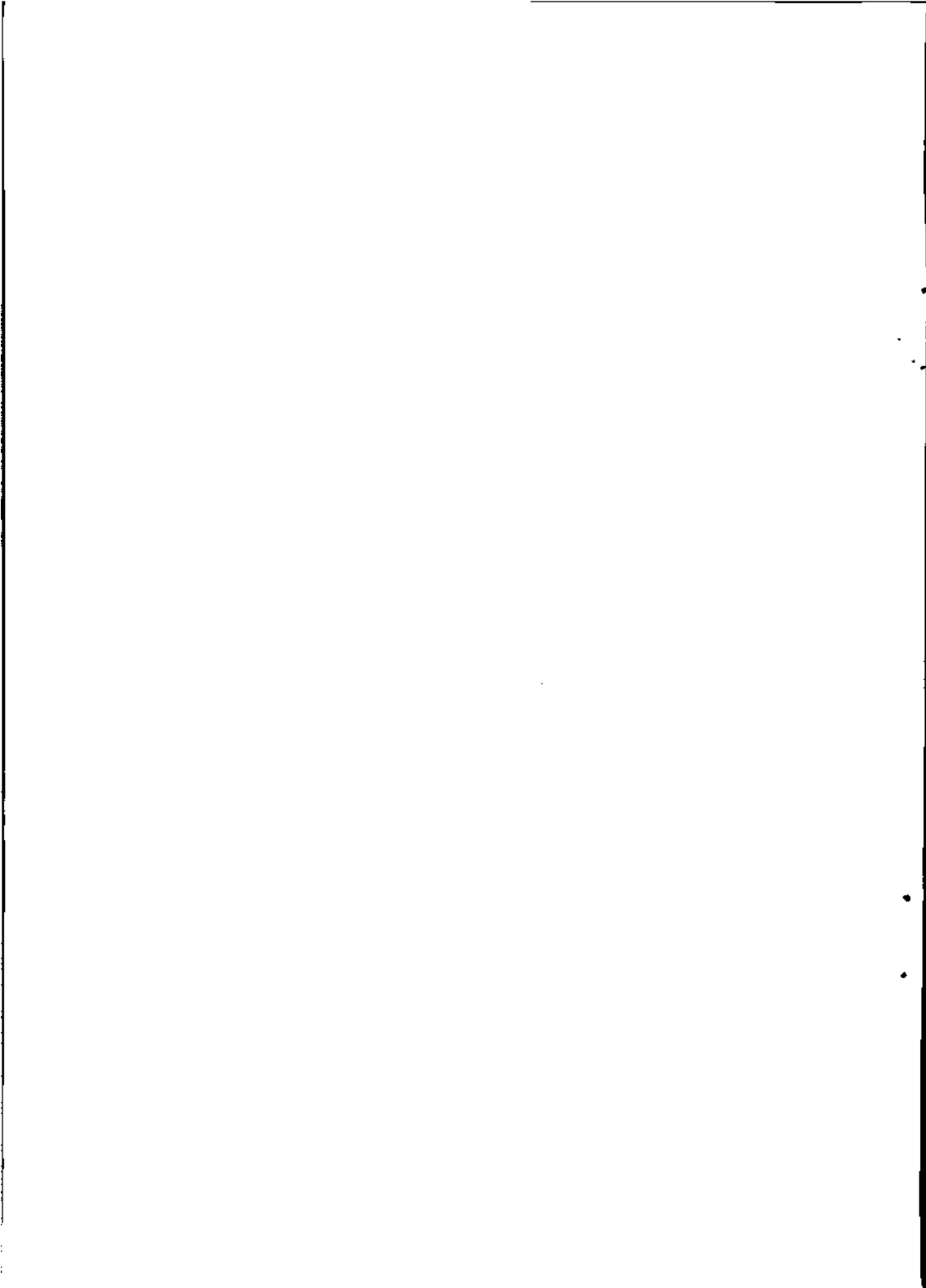

HONDA

31758600
00X31-758-6000



Printed on
Recycled Paper

POM53488

Kinko's 25.2002.05

PRINTED IN U.S.A.