

13/40

HERITAGE TRACTOR
CODE144S

INSTRUCTION BOOK

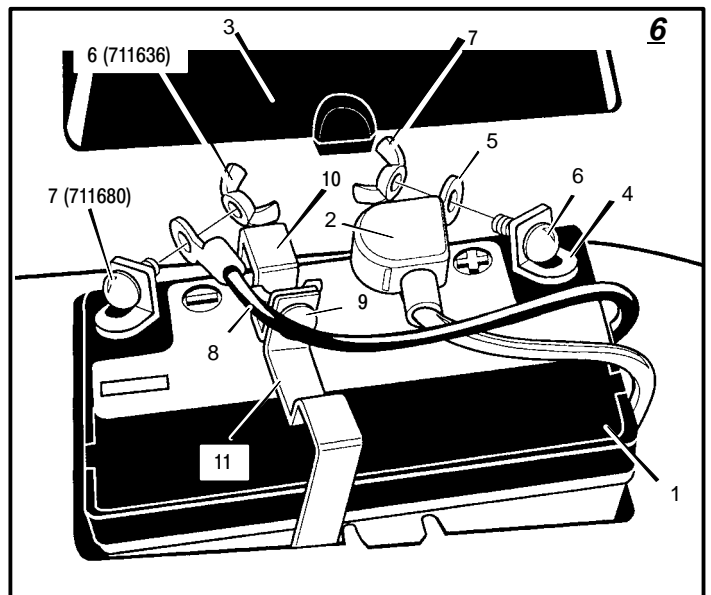

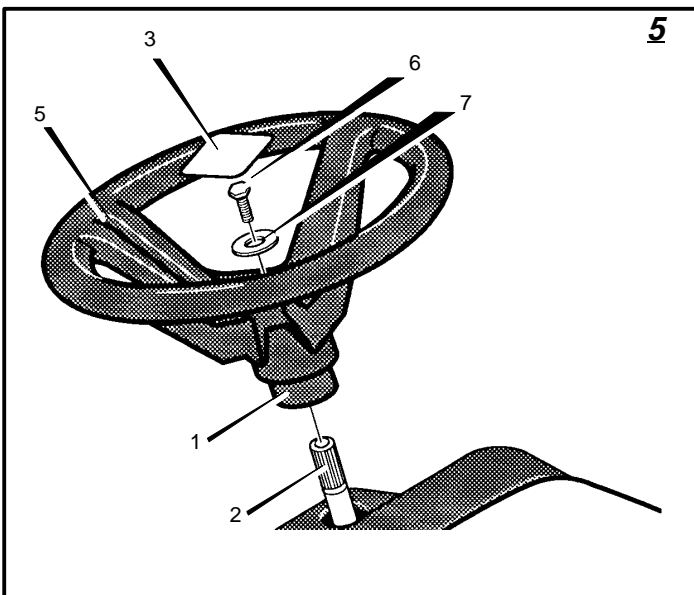
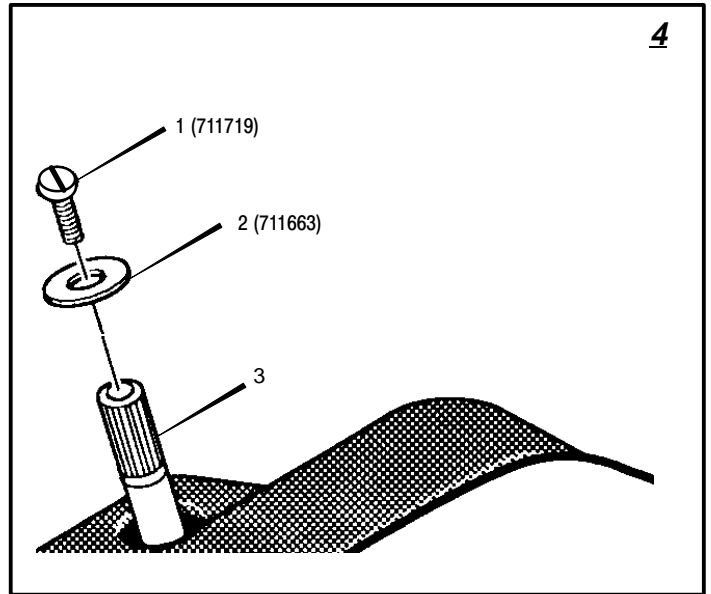
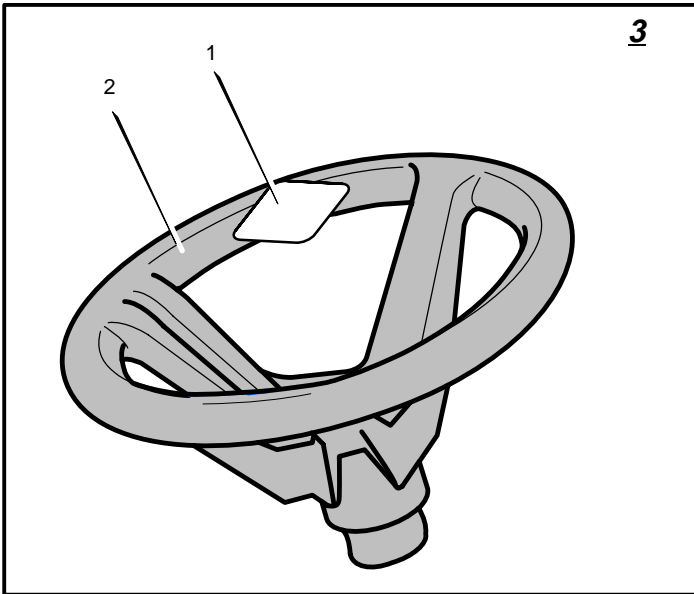
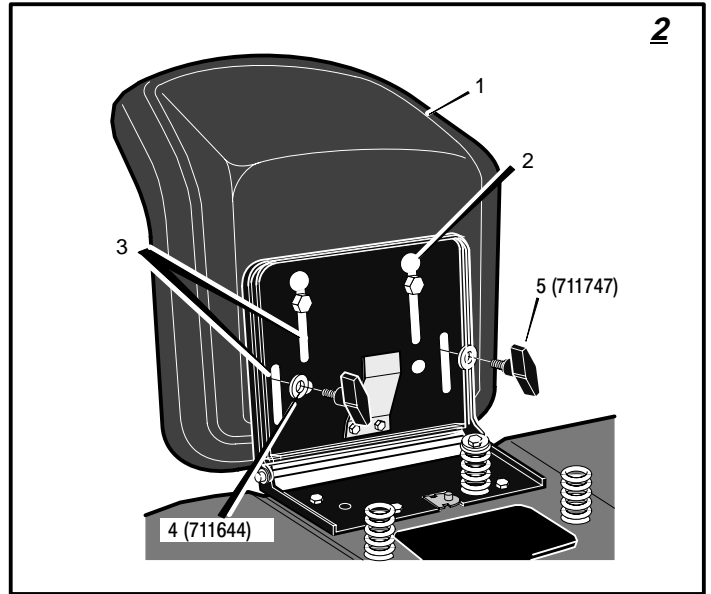
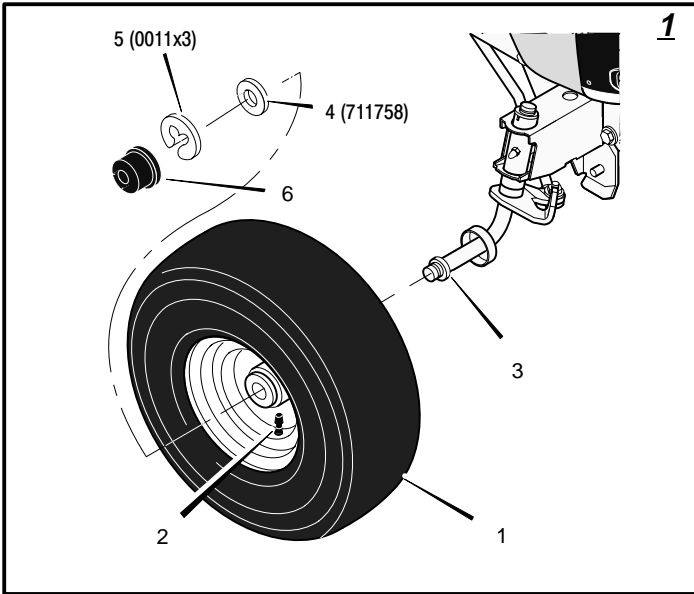
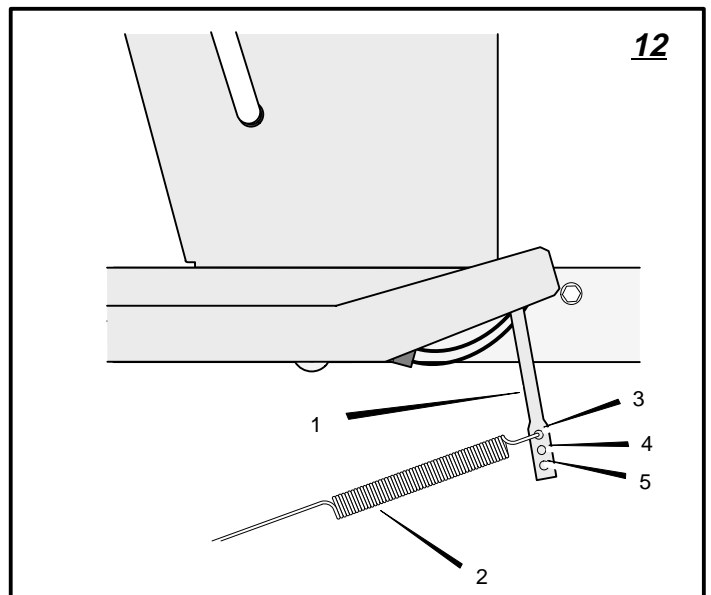
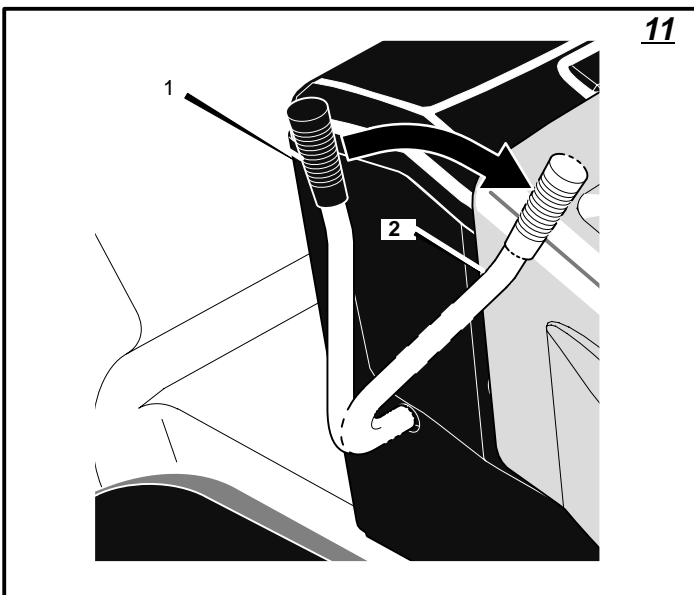
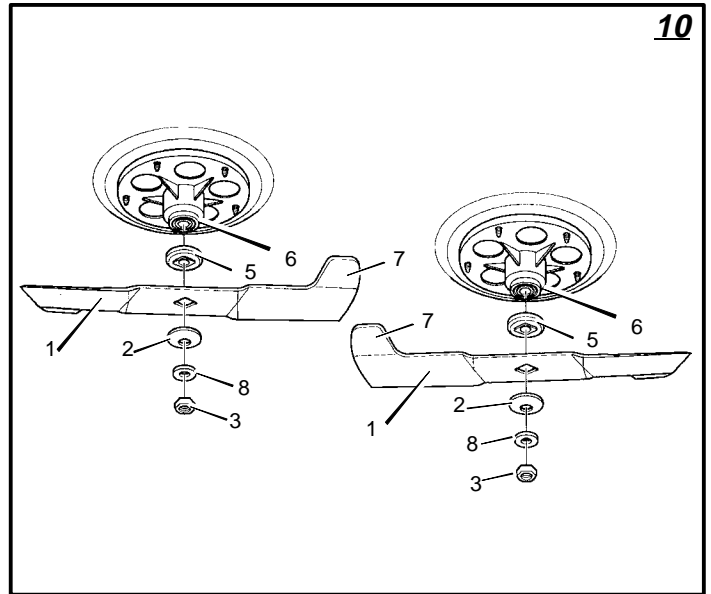
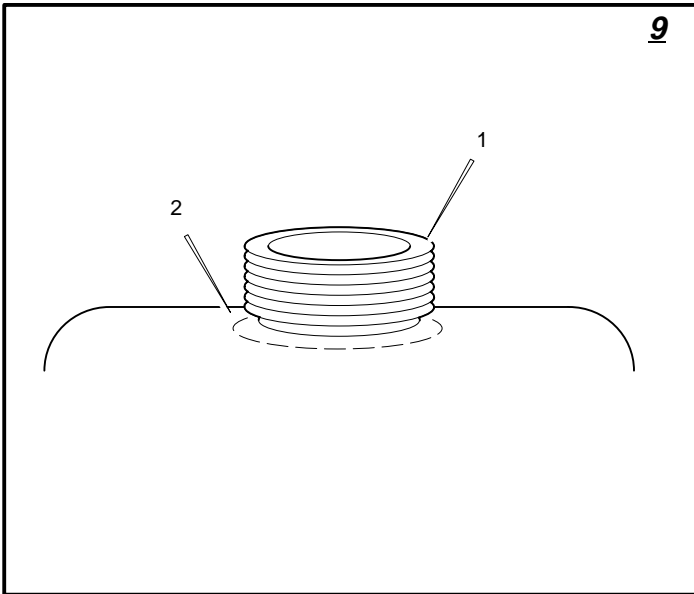
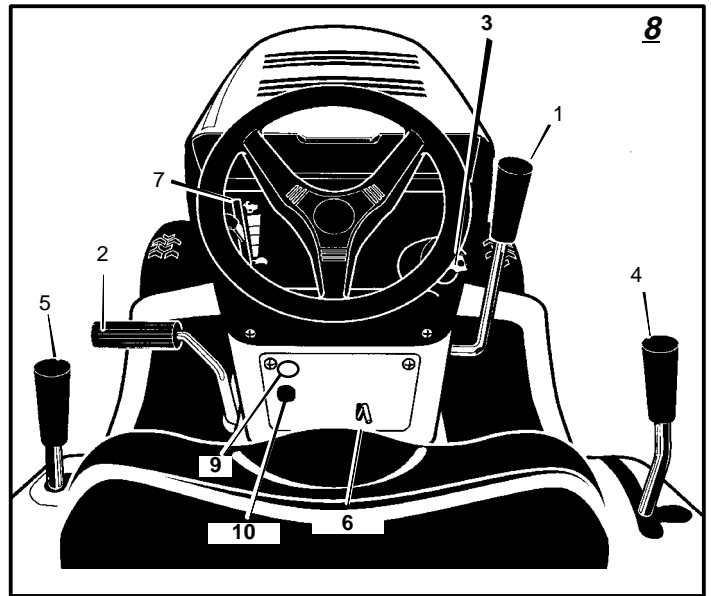
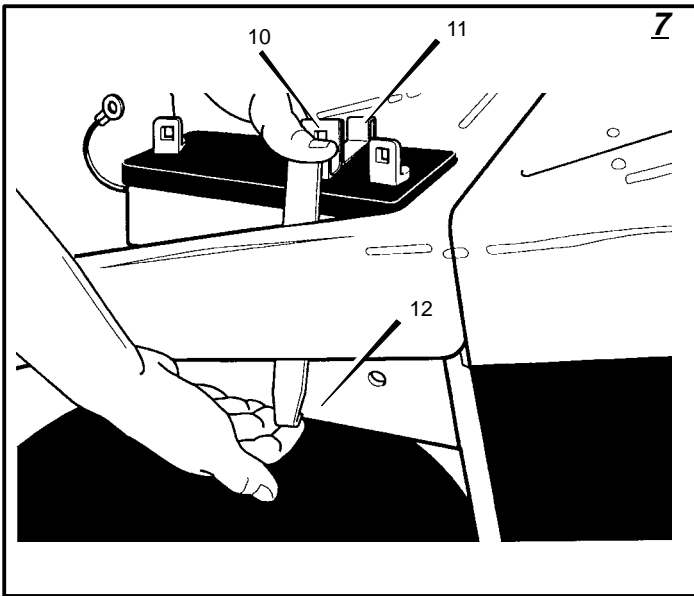

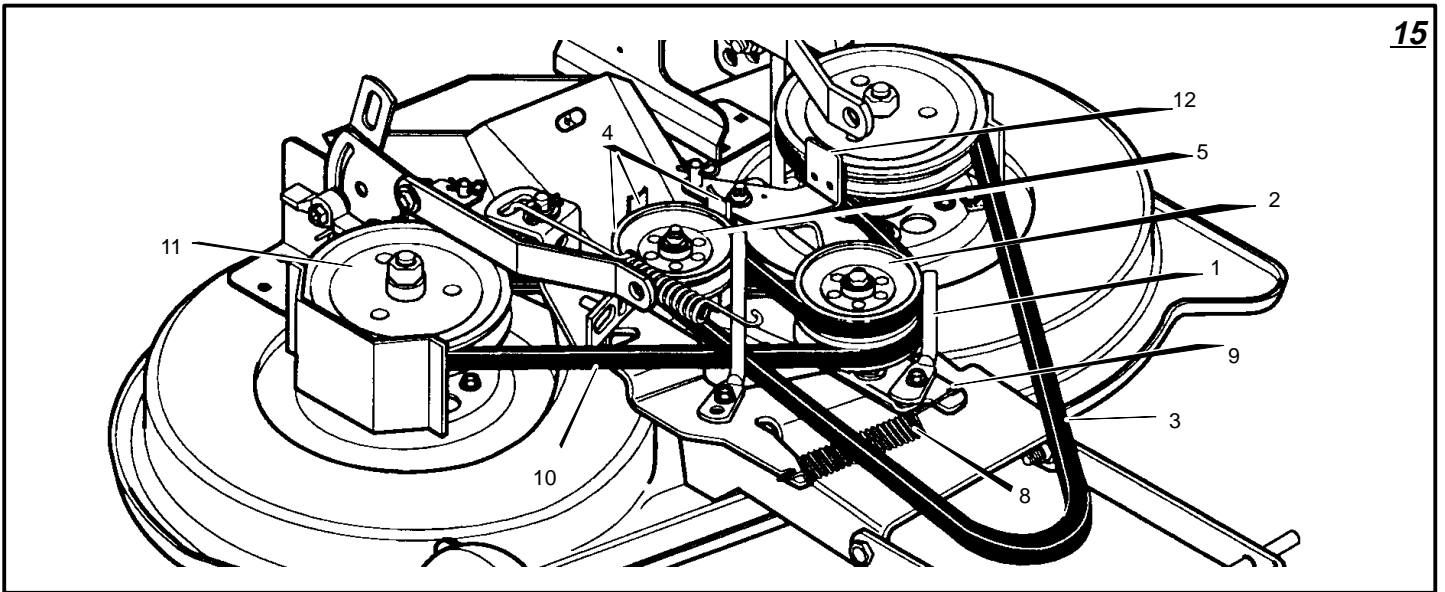
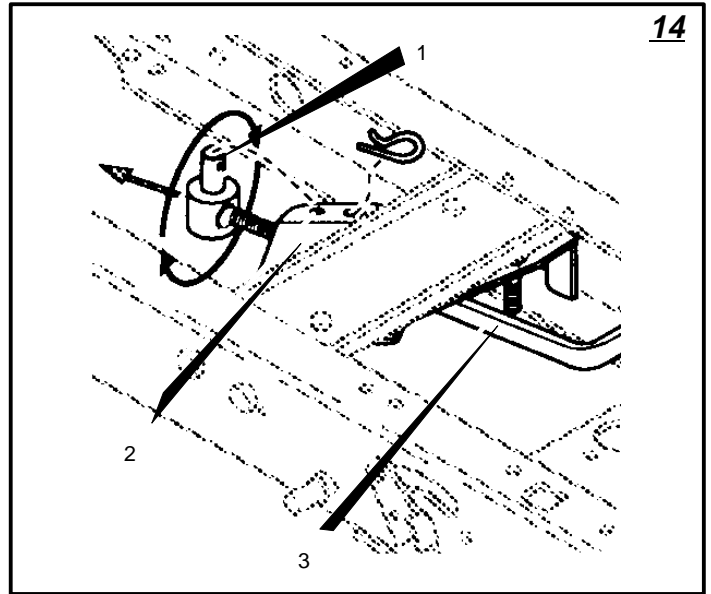
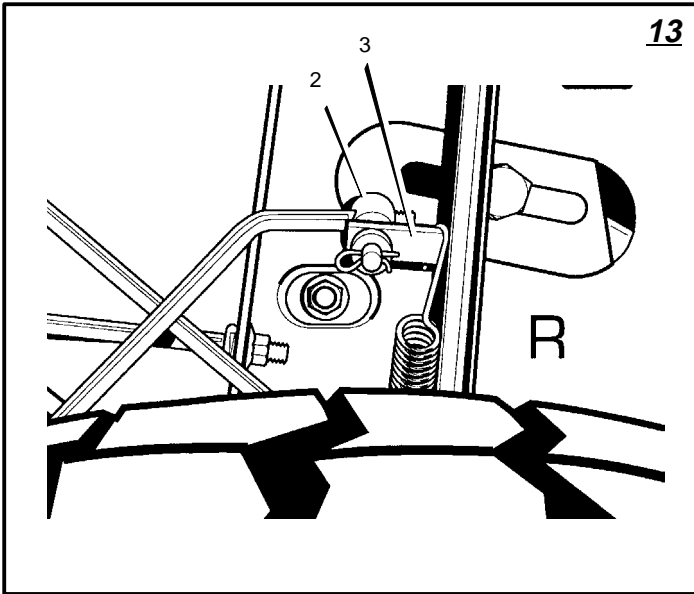

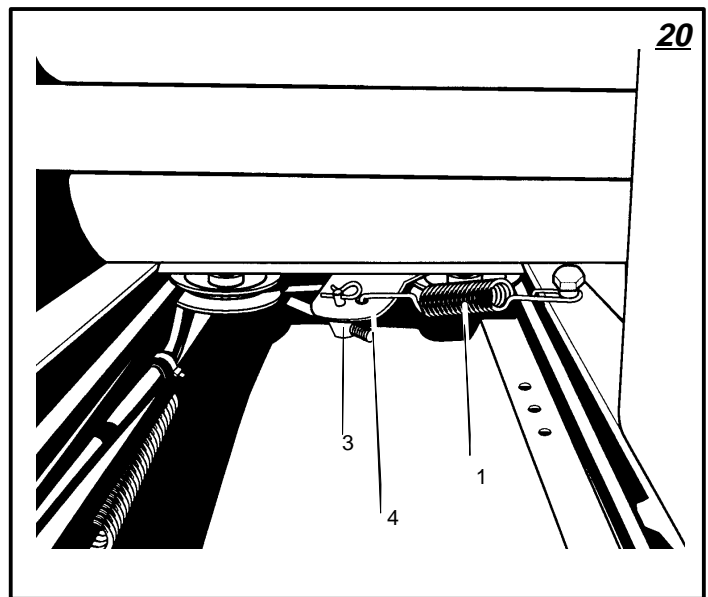
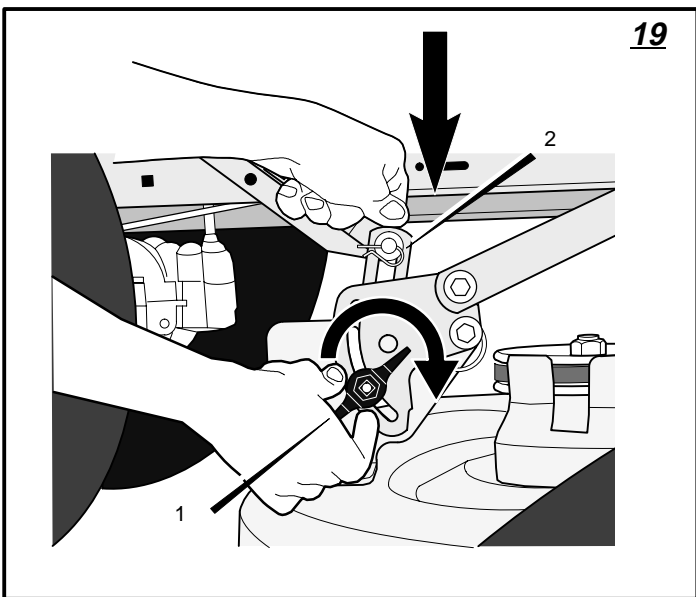
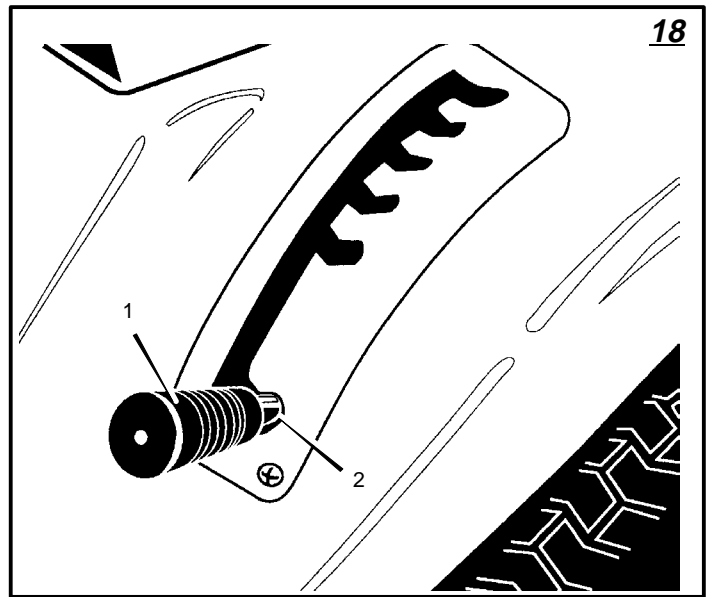
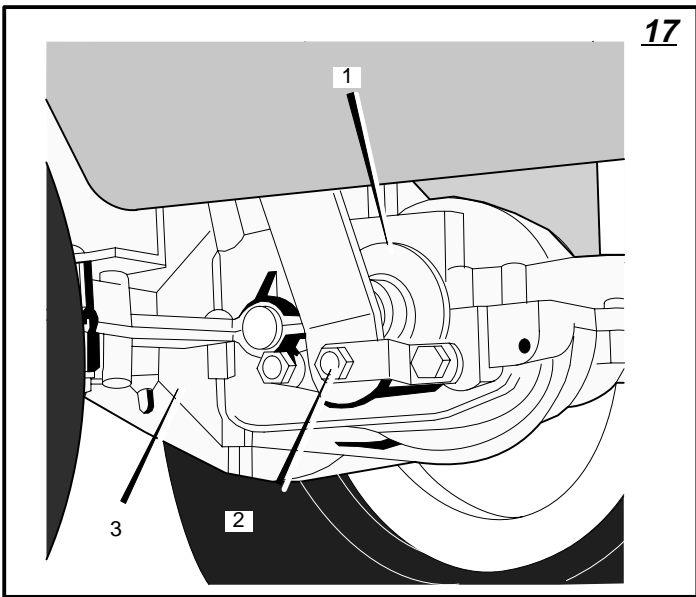
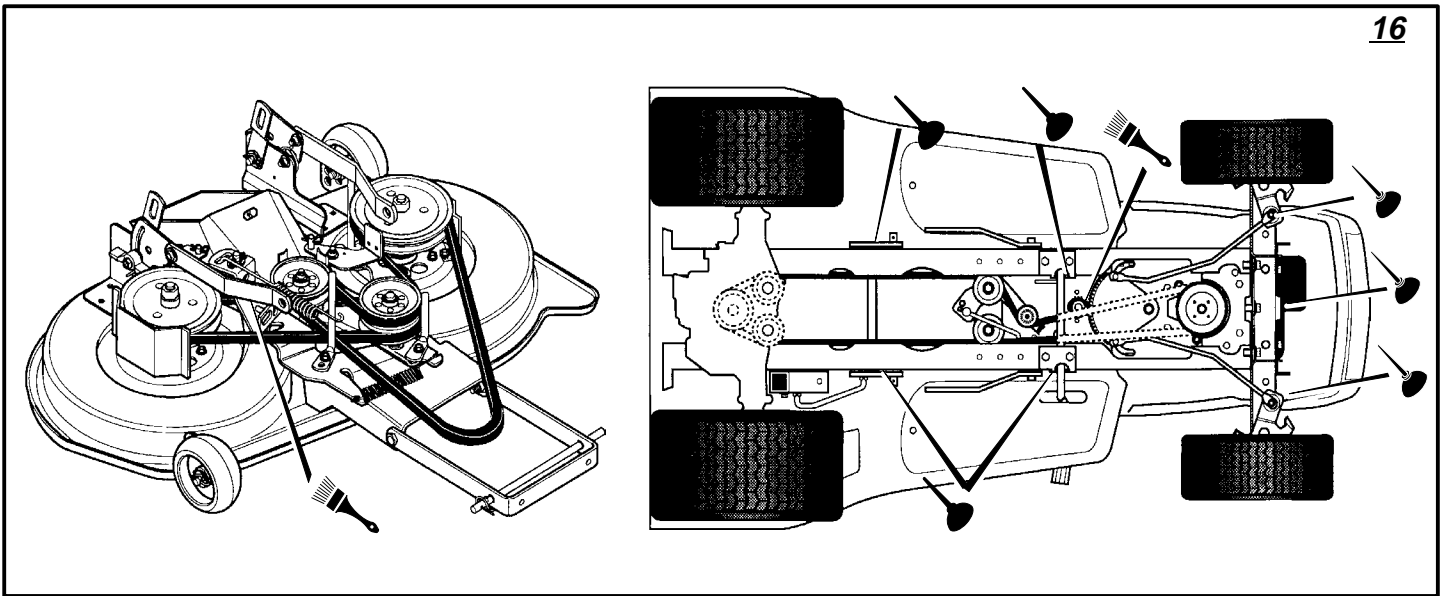

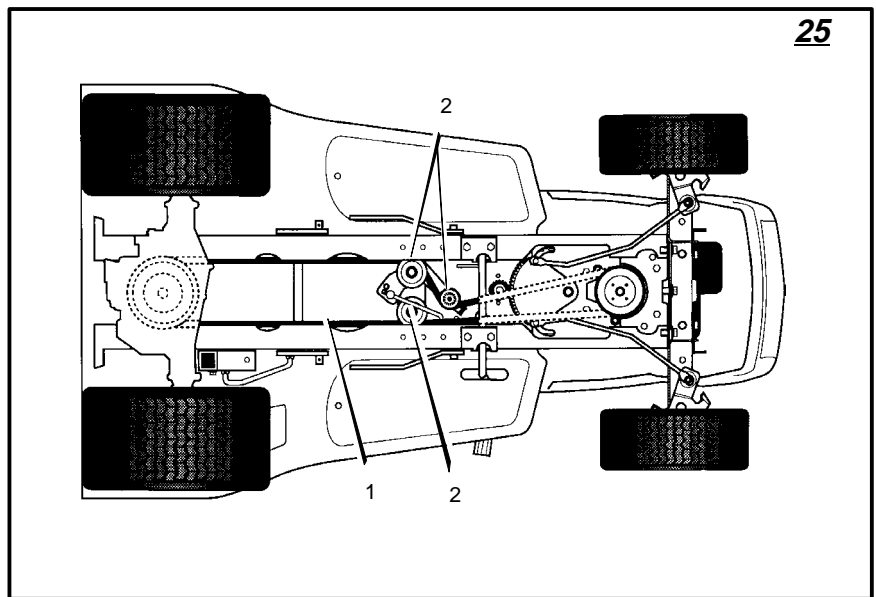
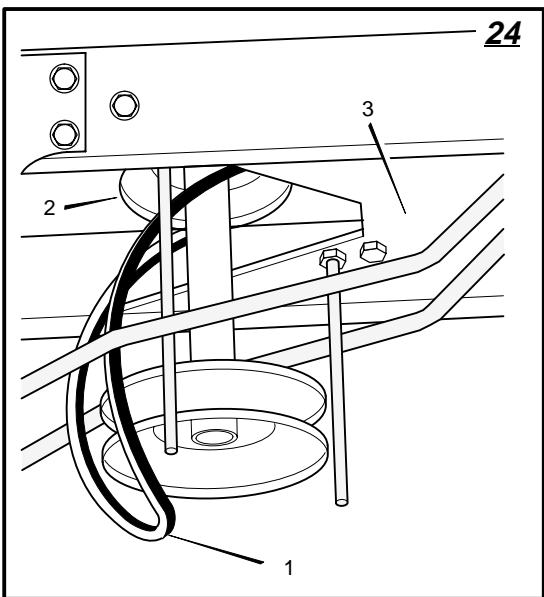
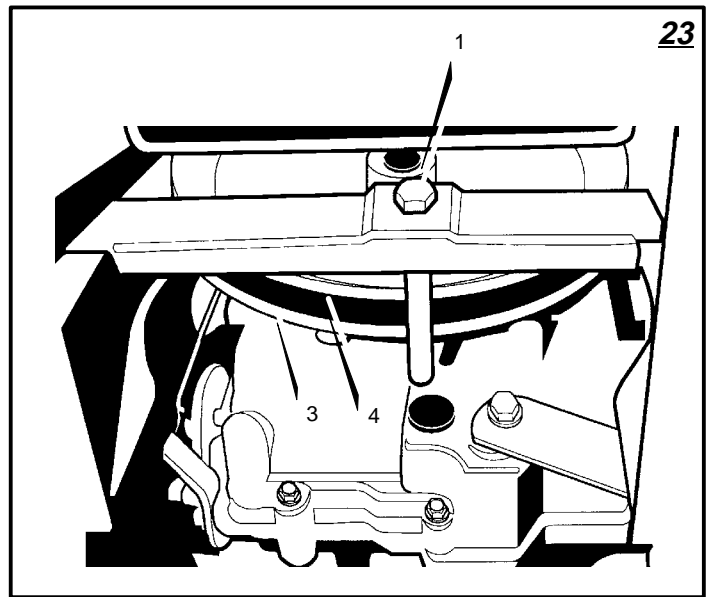
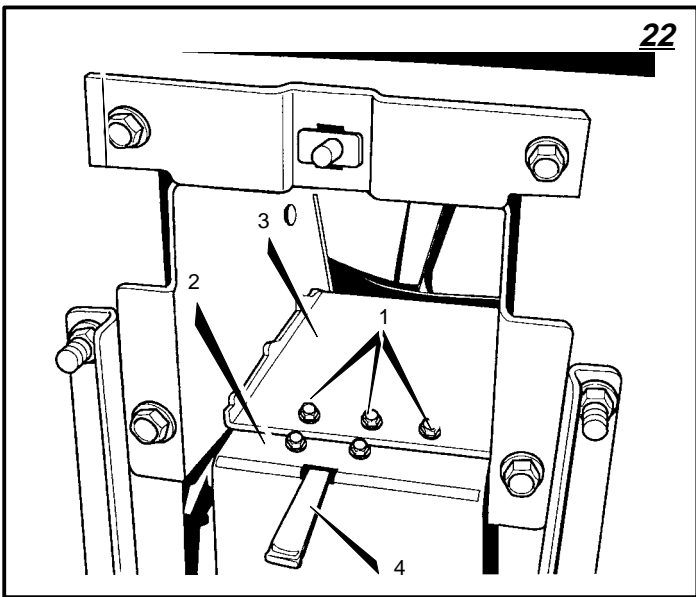
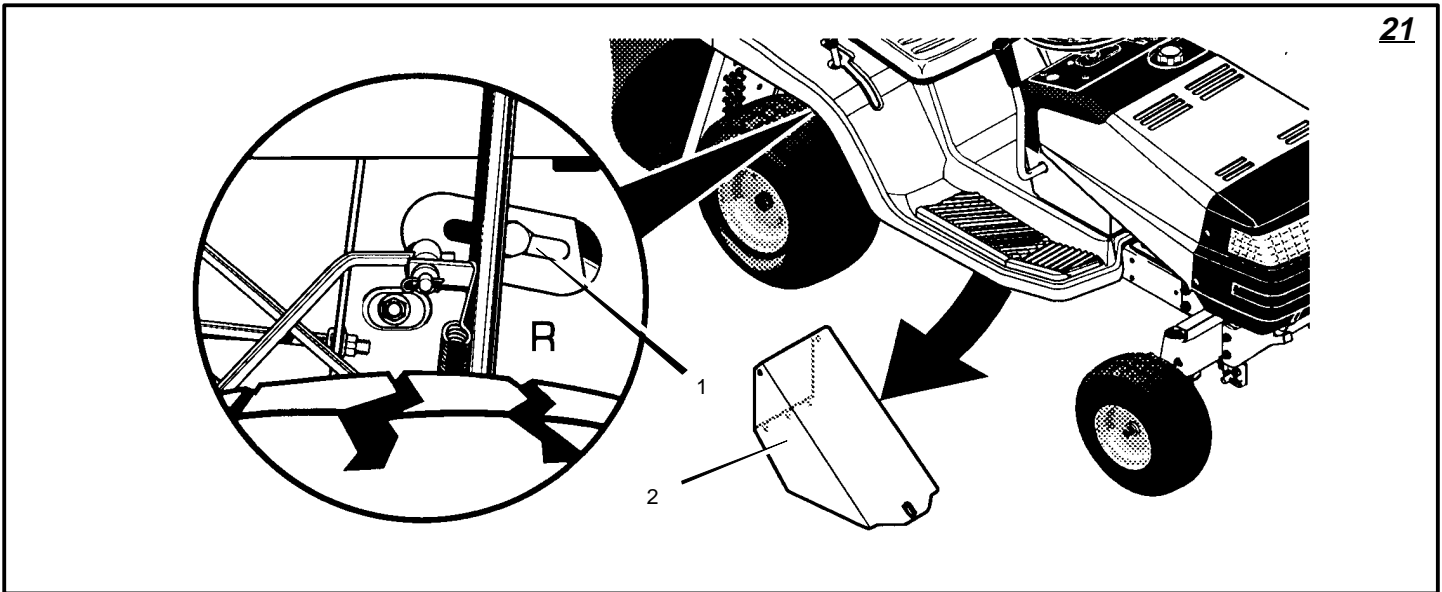

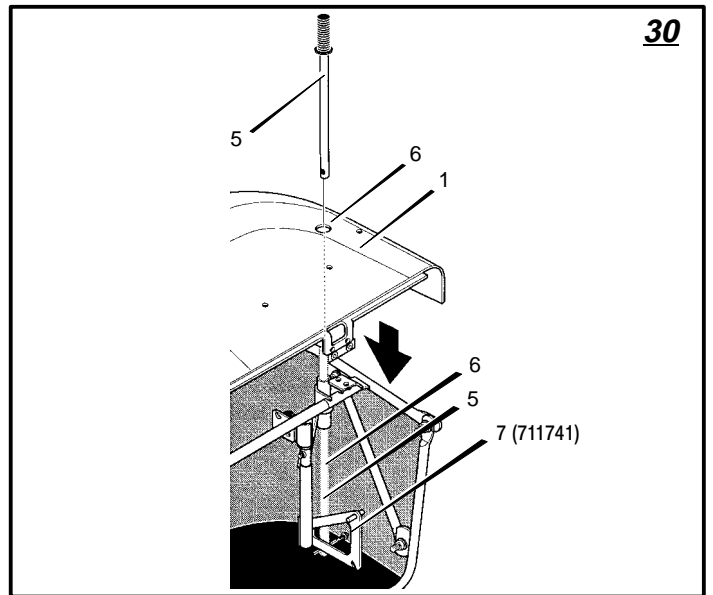
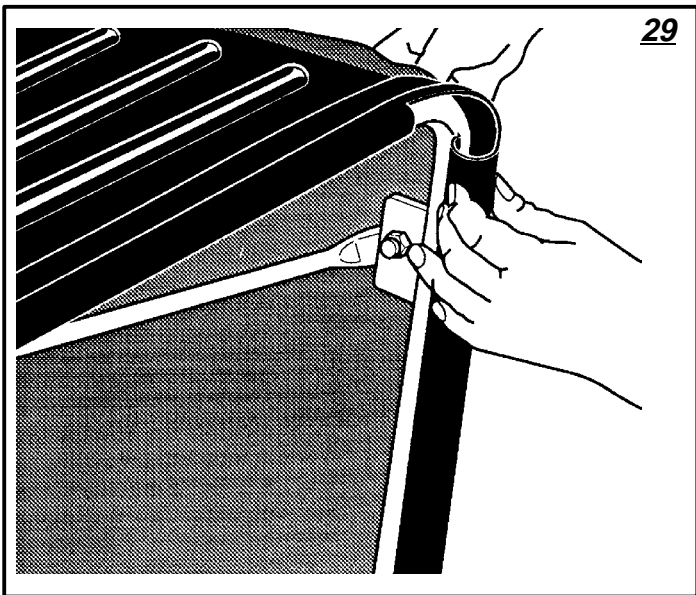
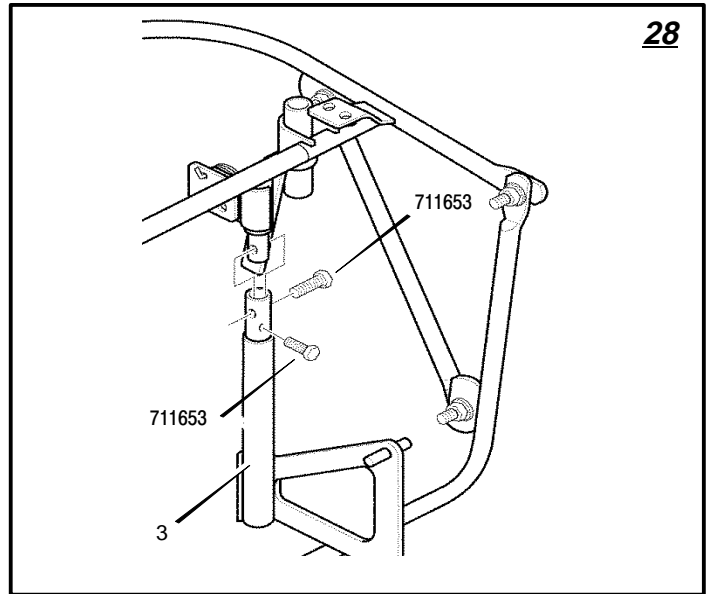
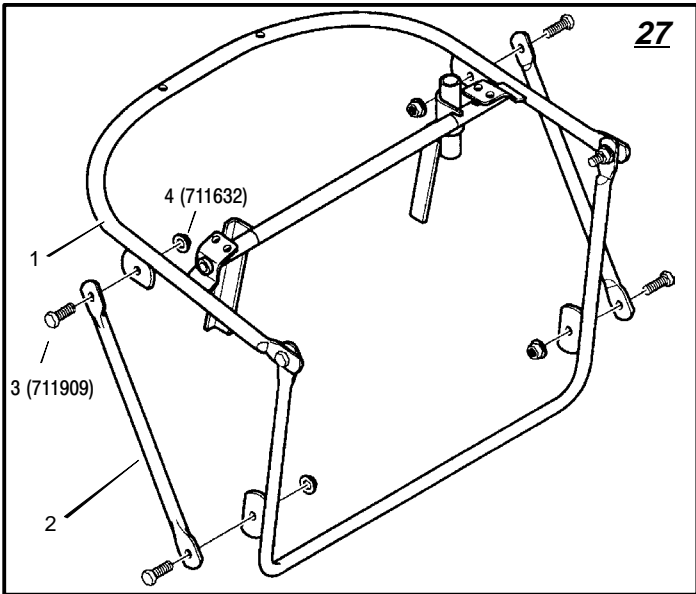
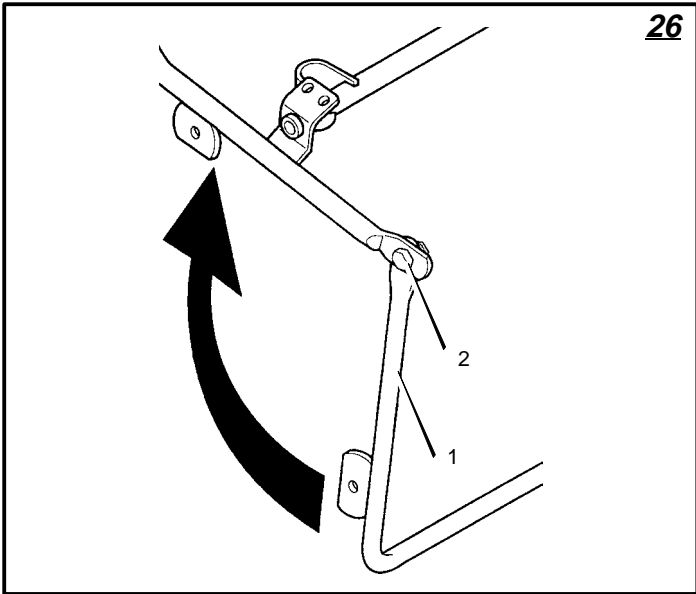

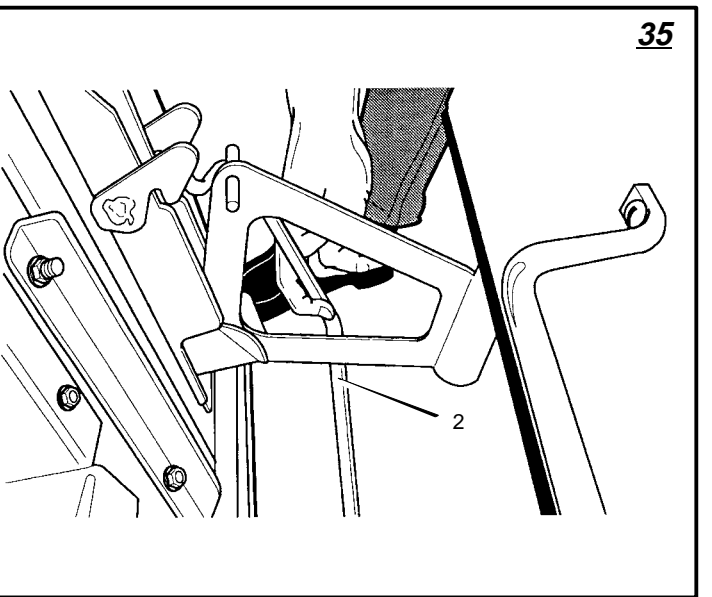
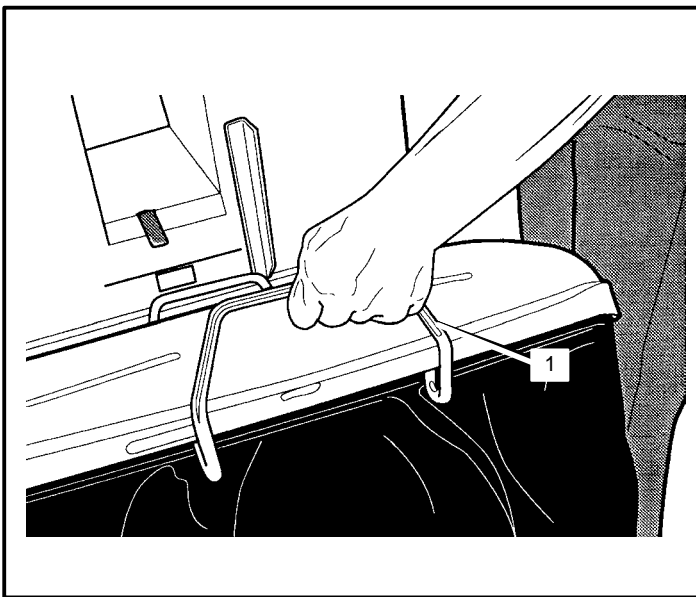
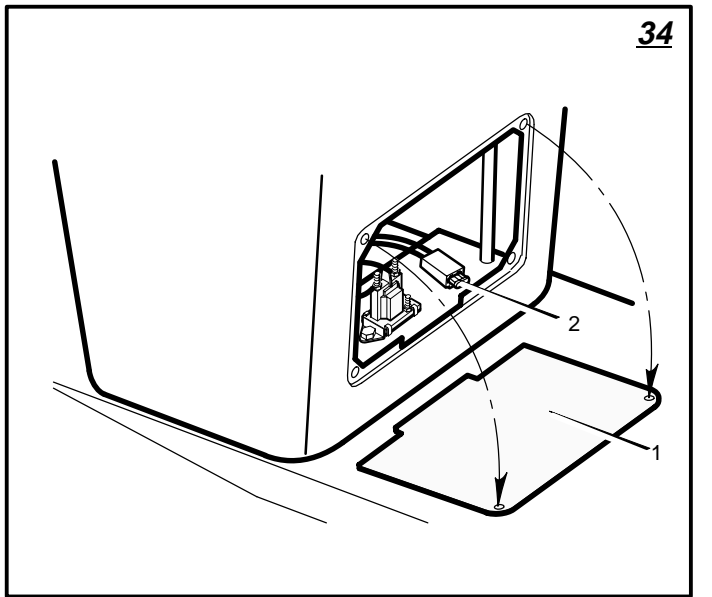
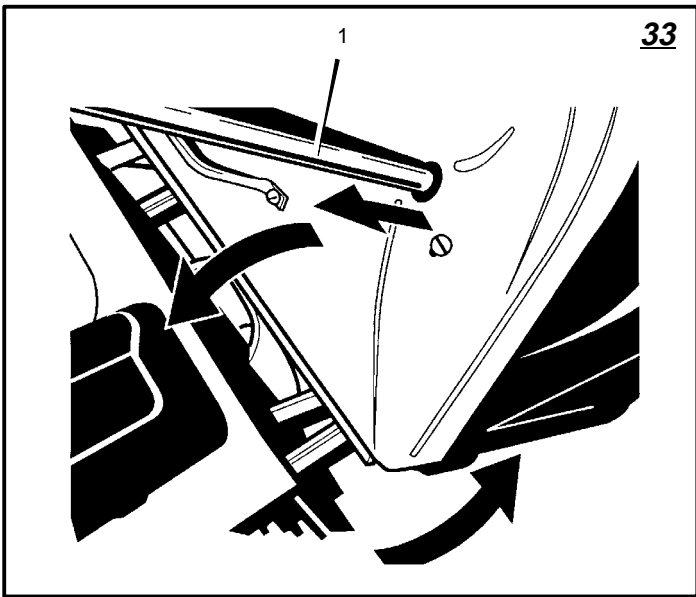
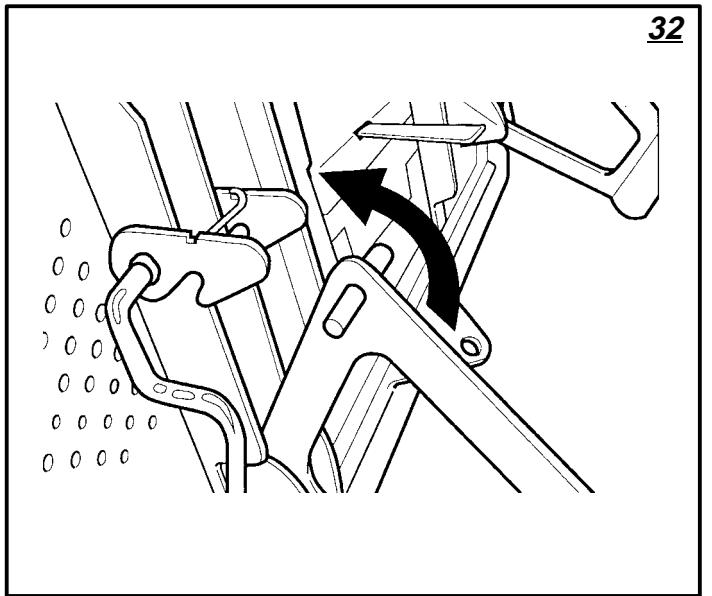
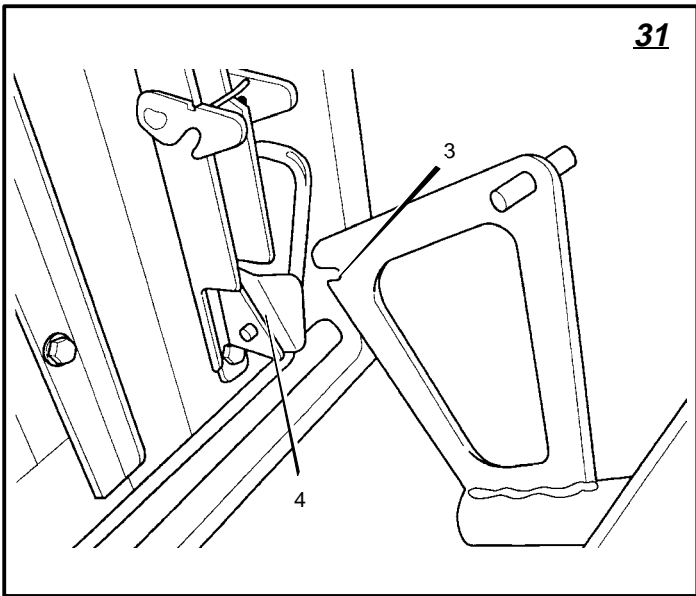

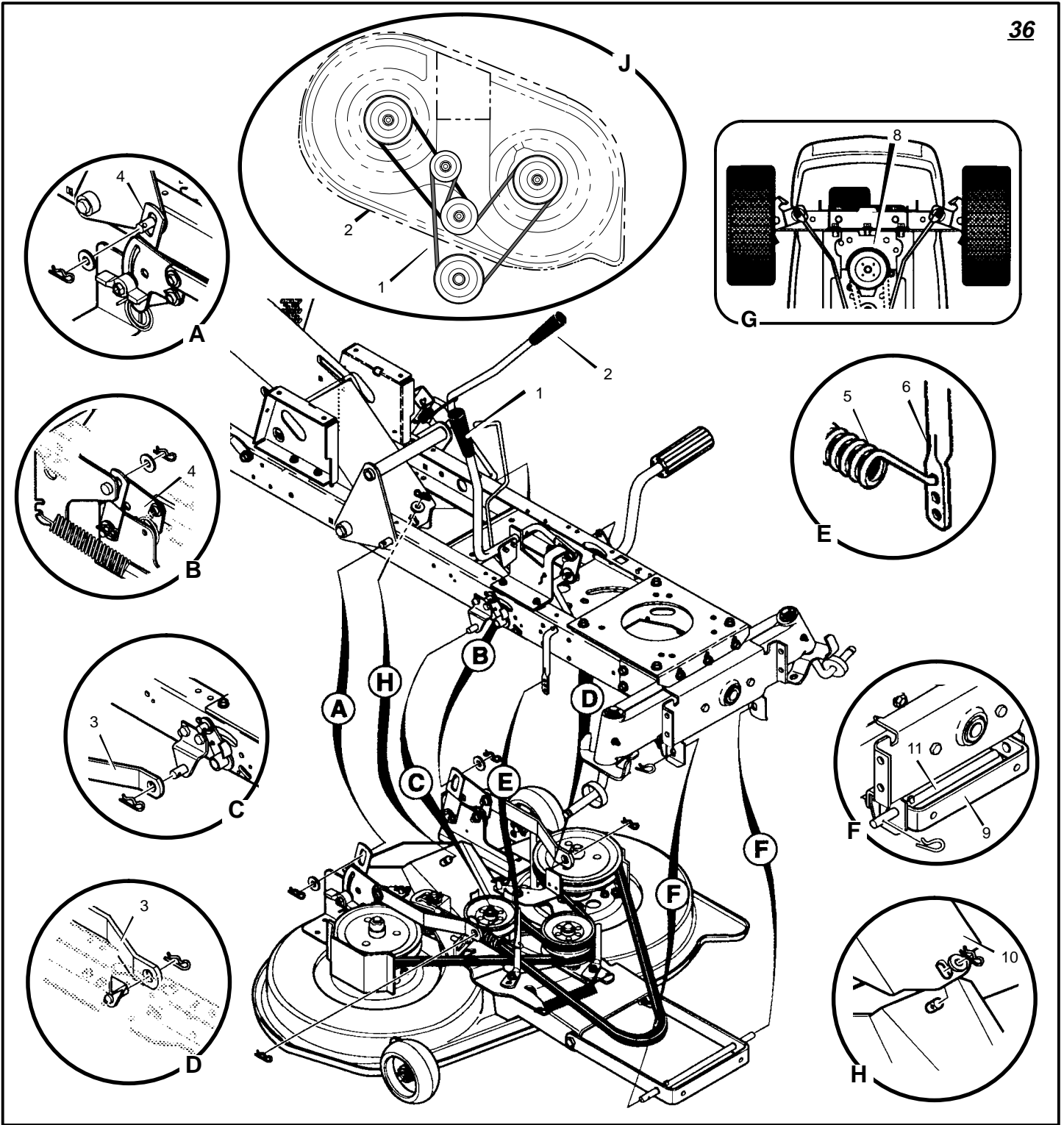

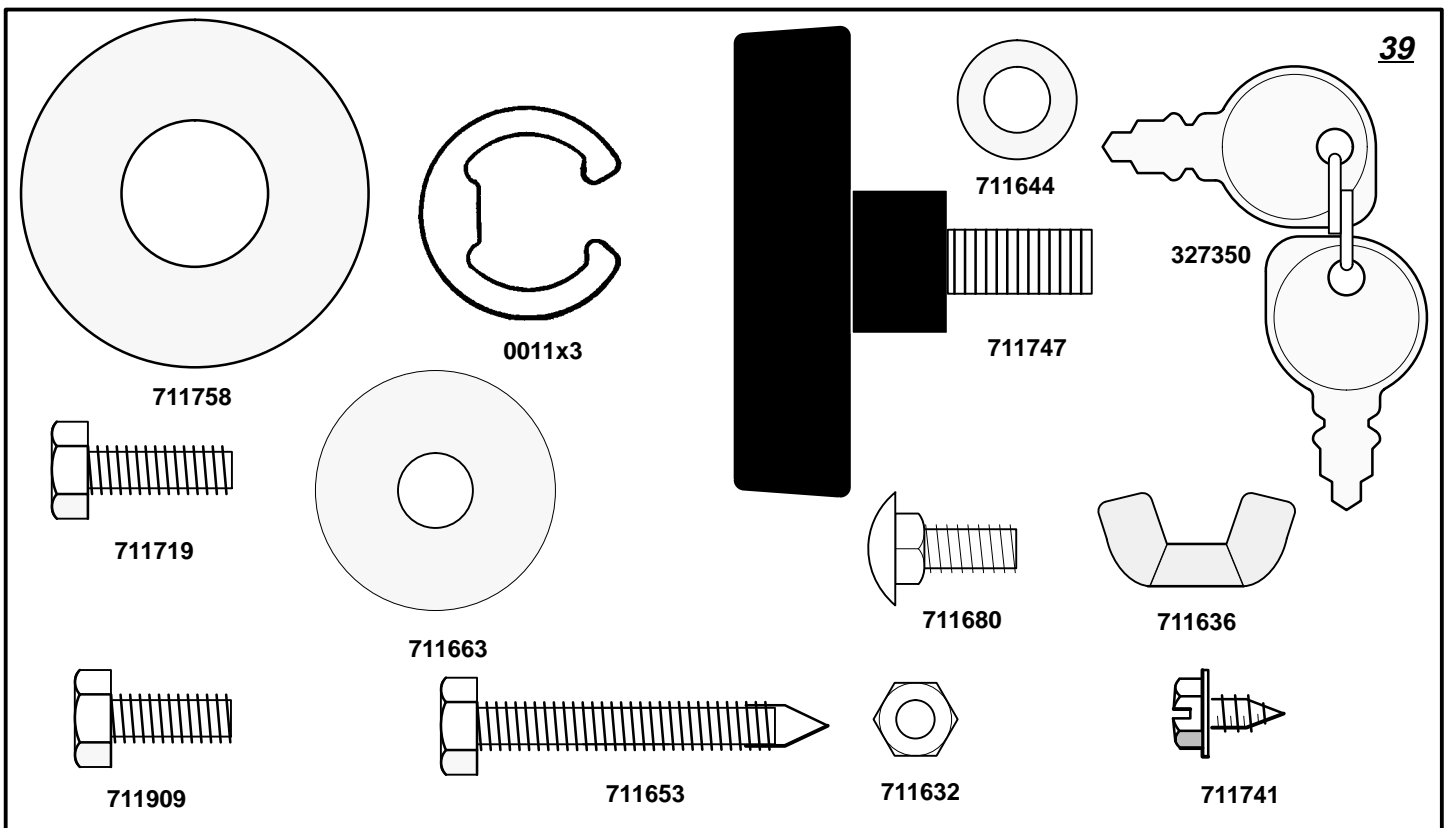
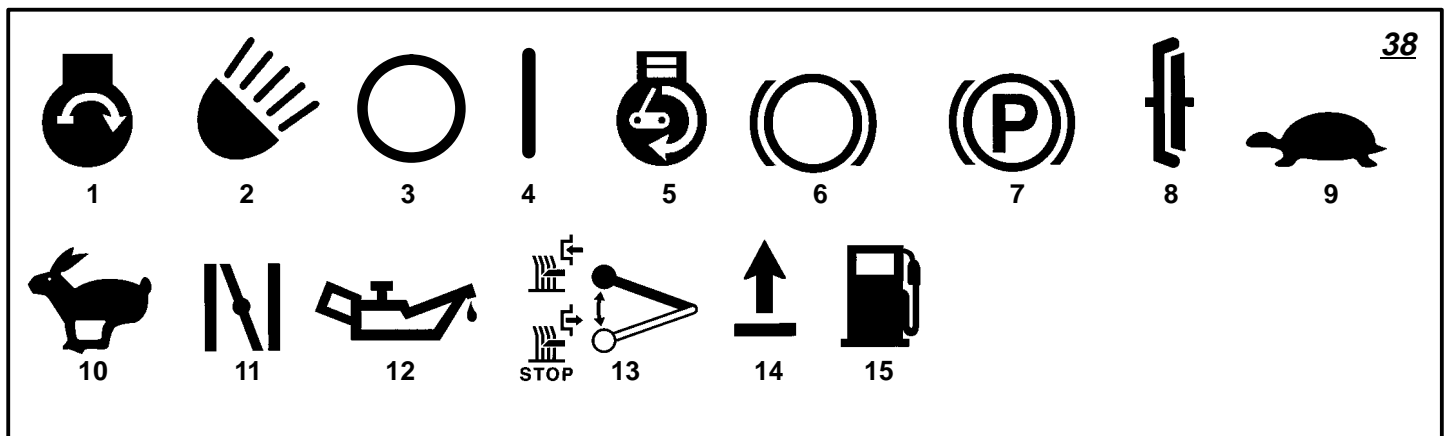
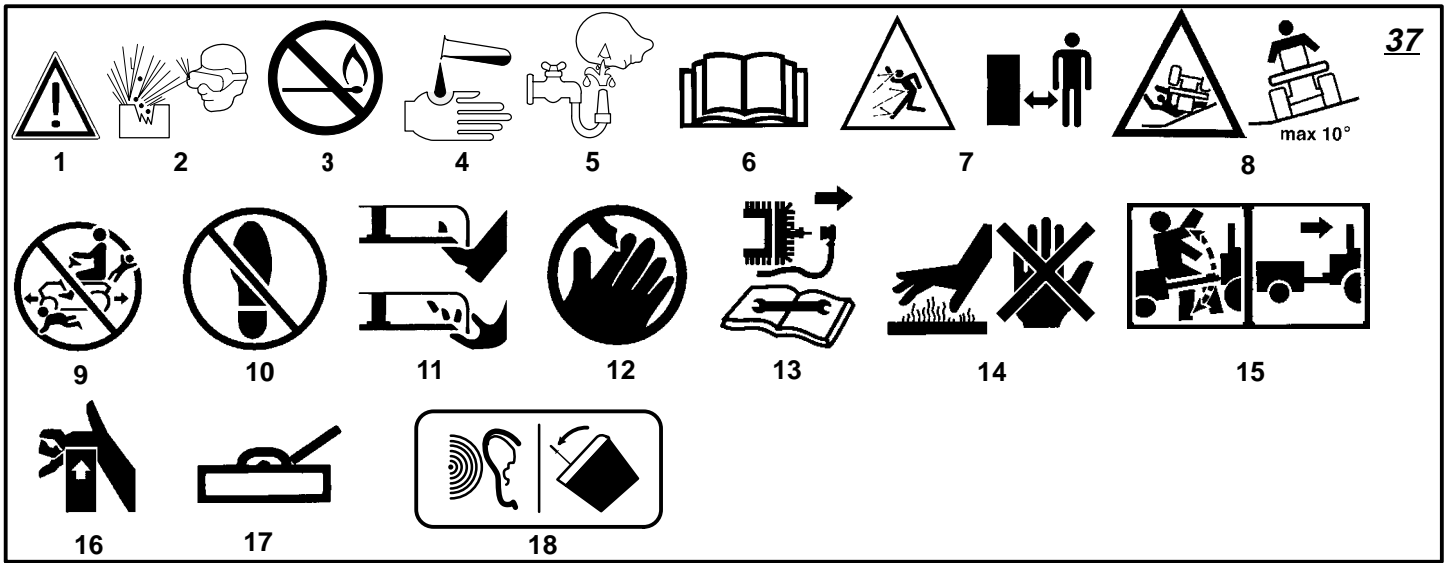

LIMITED WARRANTY

Hayter Limited warrants to the original user / purchaser that this unit shall be free from defects in material and workmanship under normal use and service for a period of **three years** from the date of purchase. The manufacturers of the engine and battery pack system (where applicable) furnish their own warranty and services are provided through their authorised network (Refer to "Engine/Battery Pack Warranty Statement"). To qualify for the full benefit of the warranty, the warranty registration card must be returned within 60 days of purchase. Subject to the conditions and exclusions noted in this limited warranty, we shall at our option, repair or replace any warranted part during the applicable period. If you are in doubt or experience any difficulty, please consult a **Hayter** Authorised Service Dealer for clarification..

To qualify for the extended warranty (second and third year) of the three year limited warranty, the machine must have annual services carried out by an Authorised Hayter Service Dealer. These chargeable services should be carried out within 12 and 24 months of the date of purchase.

Excluded from the extended warranty period are those items which are subject to normal wear and tear e.g. tyres, wheels, cutterbars, cables, batteries and other consumable wearing parts.

All consumer machines which are fitted with a **genuine** Hayter friction disc as original equipment, before use, are covered by a **Lifetime Warranty** against the engine crankshaft bending. **Note:** friction washers, blade brake units and other such devices are not applicable. Only machines fitted with a **genuine** Hayter friction disc, which are used in accordance with the recommended operating and maintenance procedures, are covered.

This warranty does not apply to any unit that has been tampered with, altered, misused, abused or used for hire, and will become invalid if non genuine Hayter parts are fitted. This warranty does not cover minor mechanical adjustments unless they are due to defective materials or workmanship. Consult the Owner's Handbook or a Hayter Authorised Service Dealer for assistance when making these adjustments.

A warranty period of 90 days applies to machines used for commercial purposes.

To make a warranty claim, return the unit to a **Hayter** authorised dealer along with proof of purchase stating the machine serial number and date of purchase. The service receipt(s) or this Owner's Handbook with the 1st/2nd year service boxes fully completed, must be produced as proof of entitlement to the extended warranty period. Subject to the conditions and exclusions in this limited warranty, the authorised dealer will, at our option, repair or replace any warranted part within the duration of the warranty period.

This limited warranty gives you specific legal rights and is in addition to any statutory rights to which you may be entitled and your statutory rights are not affected by this warranty. If you need additional information concerning this written warranty, or assistance in obtaining services, please write to:

HAYTER LIMITED, Service Department, Spellbrook, Bishop's Stortford, Hertfordshire. CM23 4BU.

UK ONLY: Details of your local **Hayter** authorised dealer are contained in Yellow Pages or contact: Freephone 0800 616298.

1st
Year
Service
Record

DEALER STAMP

2nd
Year
Service
Record

DEALER STAMP

Date
Signed

Date
Signed

CONTENTS

LIMITED WARRANTY	11
INTERNATIONAL PICTORIALS	12
OWNER'S INFORMATION	13
SAFE OPERATION PRACTICES	13
ASSEMBLY	14
OPERATION	15
MAINTENANCE	16
TROUBLE SHOOTING CHART	19

INTERNATIONAL PICTORIALS

IMPORTANT: The following pictorials are located on your unit or on literature supplied with the product. Before you operate the unit, learn and understand the purpose for each pictorial.

NOTE: Illustrations and pictorials begin on page 2.

Safety Warning Pictorials (Figure 37)

- 1 WARNING
- 2 Shield Eyes. Explosive Gases Can Cause Blindness Or Injury.
- 3 No Sparks, Flames or Smoking.
- 4 Sulphuric Acid Can Cause Blindness Or Severe Burns
- 5 Flush Eyes Immediately With Water. Get Medical Help Fast.
- 6 IMPORTANT: Read Owner's Manual Before Operating This Machine.
- 7 WARNING: Thrown Objects. Keep

Bystanders Away. Read User Instructions Before Operating This Machine.

- 8 WARNING: Do Not Use This Machine On Slopes Greater Than 10 Degrees.
- 9 DANGER: Keep People, Especially Children, Away From Unit.
- 10 DANGER: No Step.
- 11 DANGER: Keep Feet And Hands Away From Rotating Blade.
- 12 DANGER: Keep Hands Away From Rotating Blade.
- 13 DANGER: Disconnect Spark Plug Wire Before Servicing Unit.
- 14 WARNING: Hot Surface.
- 15 WARNING: Use Caution When Connecting Or Disconnecting Accessories.
- 16 WARNING: Crushed Fingers.
- 17 IMPORTANT: Follow Instructions In Owner's Manual To Level The Deck.

18 WARNING: When you hear the audible alarm it is time to empty the grass bagger.

Control And Operating Pictorials (Figure 38)

- 1 Engine Start
- 2 Lights
- 3 Engine Run
- 4 Engine Stop
- 5 Engine Run
- 6 Brake
- 7 Parking Brake
- 8 Clutch
- 9 Slow
- 10 Fast
- 11 Choke
- 12 Oil
- 13 Blade Rotation Control
- 14 Raise
- 15 Fuel

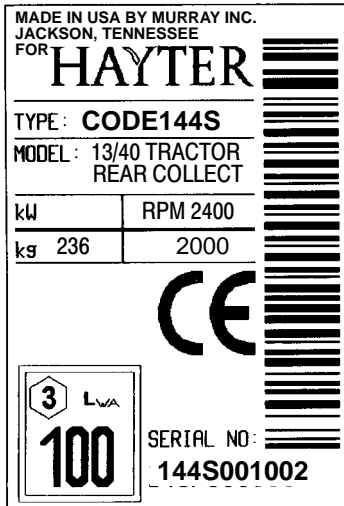

Declared vibration emission values in accordance with Directive 89/392/EEC.

Vibration Emission according to BS EN 1032: Seat < 0,50 m/s²,
Right Running Board 1,01 m/s², Left Running Board 0,76 m/s²

Vibration Emission according to BS EN 1033: Steering Wheel 4,96 m/s²

Values determined with operator in operating position when the machine was operated stationary on a grass covered surface at 2400 min⁻¹.

Declared airborne noise emissions in accordance with Directive 84/538/EEC.

Sound Power Level 100 dB(A)

Sound Pressure Levels

at operator ears 86,1 dB(A) left; 85,5 dB(A) right.

Values determined at ear according to the specifications of 81/1051/EEC.

OWNER'S INFORMATION

Know your product: If you understand the unit and how the unit operates, you will get the best performance. As you read this manual, compare the illustrations to the unit. Learn the location and the function of the controls. To help prevent an accident, follow the operating instructions and the safety rules. Keep this manual for future reference.



WARNING: Look for this symbol to indicate important safety precautions. This symbol indicates: "Attention! Become Alert! Your Safety Is At Risk."

Responsibility Of The Owner



WARNING: This cutting machine is capable of amputating hands and feet and throwing objects. Failure to observe the following safety instructions could result in serious injury or death to the operator or bystanders.

The responsibility of the owner is to follow the instructions below.

SAFE OPERATION PRACTICES

For Ride-On (Riding) Rotary Mower Machines

Training

1. Read the instructions carefully. Be familiar with the controls and the proper use of the equipment.
2. Never allow children or people unfamiliar with these instructions to use the mower. Local regulations may restrict the age of the operator.
3. Never mow while people, especially children, or pets are nearby.
4. Keep in mind that the operator or user is responsible for accidents or hazards occurring to other people or their property.
5. Do not carry passengers.
6. All drivers should seek and obtain professional and practical instruction. Such instruction should emphasize:
 - a. the need for care and concentration when working with ride-on machines;
 - b. control of a ride-on machine sliding on a slope will not be regained by the application of the brake. The main reasons for loss of control are:
 - insufficient wheel grip;
 - being driven too fast;
 - inadequate braking
 - the type of machine is unsuitable for its task;
 - lack of awareness of the effect of ground conditions, especially slopes;
 - incorrect hitching and load distribution.

Preparation

1. While mowing, always wear substantial footwear and long trousers. Do not operate the equipment when barefoot or wearing open sandals.

2. Thoroughly inspect the area where the equipment is to be used and remove all objects which may be thrown by the machine.
3. **WARNING – Petrol is highly flammable.**
 - a. Store fuel in containers specifically designed for this purpose.
 - b. Refuel outdoors only and do not smoke while refuelling.
 - c. Add fuel before starting the engine. Never remove the cap of the fuel tank or add petrol while the engine is running or when the engine is hot.
 - d. If petrol is spilled, do not attempt to start the engine but move the machine away from the area of spillage and avoid creating any source of ignition until petrol vapours have dissipated.
 - e. Replace all fuel tanks and container caps securely.
4. Replace faulty silencers.
5. Before using, always visually inspect to see that the blades, blade bolts and cutter assembly are not worn or damaged. Replace worn or damaged blades and bolts in sets to preserve balance.
6. On multi-blade machines, take care as rotating one blade can cause other blades to rotate.

Operation

1. Do not operate the engine in a confined space where dangerous carbon monoxide fumes can collect.
2. Mow only in daylight or in good artificial light.
3. Before attempting to start the engine, disengage all blade attachment clutches and shift into neutral.
4. Do not use on slopes of more than 10 degrees.
5. Remember there is no such thing as a "safe" slope. Travel on grass slopes requires particular care. To guard against overturning:
 - a. do not stop or start suddenly when going up or downhill;
 - b. engage clutch slowly, always keep machine in gear, especially when travelling downhill;
 - c. machine speeds should be kept low on slopes and during tight turns;
 - d. stay alert for humps and hollows and other hidden hazards;
 - e. never mow across the face of the slope, unless the mower is designed for this purpose.
6. Use care when pulling loads or using heavy equipment.
 - a. Use only approved drawbar hitch points.
 - b. Limit loads to those you can safely control.
 - c. Do not turn sharply. Use care when reversing.
 - d. Use counterweight(s) or wheel weights when suggested in the Instruction Book.
7. Watch out for traffic when crossing or near roadways.
8. Stop the blades rotating before crossing surfaces other than grass.
9. When using any attachments, never direct discharge of material toward bystanders nor allow anyone near the machine while in operation.
10. Never operate the mower with defective guards or shields, or without safety protective devices in place.
11. Do not change the engine governor settings or overspeed the engine. Operating an engine at excessive speed may increase the hazard of personal injury.
12. Before leaving the operator's position
 - a. disengage the power take-off and lower the attachments;
 - b. change into neutral and set the parking brake;
 - c. stop the engine and remove the key.
13. Disengage drive to attachments, stop the engine, and disconnect the spark plug wire(s) or remove the ignition key
 - a. before cleaning blockages or unclogging chute;
 - b. before checking, cleaning or working on the mower;
 - c. after striking a foreign object. Inspect the mower for damage and make repairs before restarting and operating the equipment;
 - d. if the machine starts to vibrate abnormally (check immediately).
14. Disengage drive to attachments when transporting or not in use.
15. Stop the engine and disengage drive to attachment
 - a. before refuelling;
 - b. before removing the grass catcher;
 - c. before making height adjustment unless adjustment can be made from the operator's position.
16. Reduce the throttle setting during engine run-out and, if the engine is provided with a shut-off valve, turn the fuel off at the conclusion of mowing.
17. Before and when backing, look **behind and down** for small children.
18. Use extra care when approaching blind corners, shrubs, trees or other objects that may obscure vision.

Maintenance and Storage

1. On multi-blade machines, take care as rotating one blade can cause other blades to rotate.
2. When machine is to be parked, stored or left unattended, lower the cutting means unless a positive mechanical lock is used.
3. Keep all nuts, bolts, and screws tight to be sure the equipment is in safe working condition.
4. Never store the equipment with petrol in the tank inside a building where fumes may reach an open flame or spark.
5. Allow the engine to cool before storing in any enclosure.
6. To reduce the fire hazard, keep the engine, silencer, battery compartment and petrol storage area free of grass, leaves, or excessive grease.
7. Check the grass catcher frequently for wear or deterioration.
8. Replace worn or damaged parts for safety.
9. If the fuel tank has to be drained, this should be done outdoors.

ASSEMBLY

All fasteners are in the parts bag. Do not discard any parts or material until the unit is assembled.



WARNING: Before doing any assembly or maintenance to the mower, remove the wire from the spark plug.

NOTE: In this instruction book, left and right describe the location of a part with the operator on the seat.

NOTE: Illustrations and pictorials begin on page 2.

NOTE: To assemble the following loose parts, use the fasteners shown at full size in Figure 39.

How To Install The Front Wheels (Figure 1)

Use a knife and cut the four sides of the container. Install the front wheels (1) in the container.

NOTE: Use a piece of wood about 4 feet (1.25 meters) long to raise the front of the tractor. If a piece of wood cannot be found, get another person to help lift the tractor. Be careful, do not let the tractor fall.

1. Raise the front of the tractor. Set a support (block of wood) under the tractor.
2. Make sure the valve stem (2) is to the outside of the tractor. Slide the front wheel (1) on the spindle (3).
3. Fasten each front wheel (1) with washer (4) and e-ring (5).
4. After the front wheels (1) are installed, lift the tractor from the support. Roll the tractor off of the container.
5. If your tractor has hub caps (6), install the hub caps (6). Make sure the washers (4) hold the hub caps (6) in place.

How To Install The Seat (Figure 2)

1. Carefully remove the plastic bag from the seat (1).
NOTE: For shipping purposes, the fasteners may be attached to the seat. Before proceeding, remove the fasteners.
2. Align the holes in the seat hinge (2) to the bolts in the seat (1). Fasten the seat (1) to the seat hinge (2) with the fasteners (4) and (5).
3. Check the operating position of the seat (1). If the seat (1) needs to be adjusted, loosen the two wing bolts (5). Slide the seat (1) forward or backward along the seat adjusting holes (3). Tighten the wing bolts (5).

How To Assemble The Steering Wheel

1. (Figure 3) For shipping purposes, the hub cover (1) is taped to the center of the steering wheel (2). Remove the hub cover (1) and set aside.
2. (Figure 4) Remove screw (1) and washers (2) from the steering post (3) and set aside.
3. Make sure the front wheels point forward.
4. (Figure 5) From the operator's position, make sure the split spoke (5) of the steering wheel is pointing toward you. Slide the steering wheel (1) onto the steering post (2).
5. Use screw (6) and washer (7), set aside earlier, to secure the steering wheel (1). Tighten the screw (6). DO NOT over tighten.

F-000786J

6. Remove the adhesive backing from the hub cover (3) that was set aside earlier. Attach the hub cover (3) to the center of the steering wheel (1).
7. Some models have an optional decal in the parts bag. Attach the decal to the center of the steering wheel (1).

Maintenance Free Battery (Figure 6)

IMPORTANT: Before you attach the battery cables to the battery, check the battery date. The battery date tells if the battery must be charged.

1. Check the top of the battery (1) for the location of the battery date.
2. If the battery (1) is put into service before the battery date, the battery cables can be attached without charging the battery (1). See "How To Install The Battery Cables".
3. If the battery (1) is put into service after the battery date, the battery (1) must be charged. See "How To Charge The Maintenance Free Battery".

How To Charge The Battery



WARNING: When you charge the battery, do not smoke. Keep the battery away from any sparks. The fumes from the battery acid can cause an explosion.

1. (Figure 6) Remove the battery cover (3).
2. Remove the fasteners (9) from the battery brackets (10, 11).
3. (Figure 7) Apply pressure to battery bracket (10) and remove battery bracket (10) from frame (12) as shown.
4. Remove battery bracket (11).
5. Remove the battery (1).
6. Remove the protective caps from the battery terminals.
7. Use a 12 volt battery charger to charge the battery (1). Charge at a rate of 6 amperes for one hour. If you do not have a battery charger, have an authorized service centre charge the battery.
8. Install the battery (1).
9. Install battery brackets (10, 11).

NOTE: Make sure battery brackets (10, 11) are installed into the slots in the frame (12) before tightening the fasteners.

How To Install The Battery Cables (Figure 6)



WARNING: To prevent sparks, fasten the red cable to the positive (+) terminal before you connect the black cable.

1. Remove the protective caps from the battery terminals.
NOTE: For shipping purposes, the fasteners may be attached to the battery terminals. Remove the fasteners before proceeding.
2. Fasten the red cable (5) to the positive (+) terminal (4) with the fasteners (6) and (7). Slide the terminal cover (2) onto the positive (+) terminal (4).

3. Fasten the black cable 8 to the negative (-) terminal with the fasteners (6) and (7).
4. Install the battery cover (3).

How To Assemble The Grass Bagger

1. Put the grass bagger on a flat surface.
2. (Figure 26) Open the frame (1). Tighten fasteners (2).
3. (Figure 27) Attach braces (2) to the frame assembly (1) with screws (3) and nuts (4). Make sure all fasteners are tight.
4. (Figure 28) Attach the bag support brackets (3) with the fasteners as shown.
5. (Figure 29) Secure the bag to the frame.
6. (Figure 30) On the left side of the grass bagger assembly (1), slide the handle (5) in the tube (6).
7. Fasten the handle (5) with screw (7).

How To Mount The Grass Bagger On The Tractor

1. (Figure 31) Mount the slots on the support brackets (3) onto the pins (4) on the back plate of the tractor.
2. (Figure 32) Hold rear handle and rotate the grass bagger in operating position. Snap into place.

How To Prepare The Engine

NOTE: The engine was shipped from the factory filled with oil. Check the level of the oil. Add oil as needed.

See the engine manufacturer's instructions for the type of petrol and oil to use. Before you use the unit, read the information on safety, operation, maintenance, and storage.



WARNING: Follow the engine manufacturer's instructions for the type of petrol and oil to use. Always use a safety petrol container. Do not smoke when adding petrol to the engine. When inside an enclosure, do not fill with petrol. Before you add petrol, stop the engine. Let the engine cool for several minutes.

Check The Tyres

Check the air pressure in the tyres. Tyres with too much air pressure will cause the unit to ride rough. Also, the wrong air pressure will keep the mower housing from cutting level. The correct air pressure is: Front Tyres 1,38 BAR (20 PSI), Rear Tyres 0,97 BAR (14 PSI). The tyres were over-inflated for shipment.

Check The Level Of The Mower Housing

Make sure the level of cut is still correct. After you mow a short distance, look at the area that was cut. If the mower housing does not cut level, see the instructions on "How To Level The Mower Housing" in the Maintenance section of this instruction book.

Important! Before You Start Mowing

- Check the engine oil.
- Fill the fuel tank with petrol.
- Check the level of the mower housing.
- Check the air pressure of the tyres.
- Attach the battery cables.

OPERATION

NOTE: Illustrations and pictorials begin on page 2.

Location Of Controls (Figure 8)

Blade Rotation Control (1): Use the blade rotation control to start and stop the rotation of the blade.

Clutch / Brake Pedal (2): The pedal has two functions. The first function is a clutch. The second function is a brake.

Headlight Switch (3): The headlight switch is the first part of the ignition switch. To use the lights with the engine running, turn the key to the position for the lights.

Ignition Switch (3): Use the ignition switch to start and stop the engine.

Shift Lever (4): Use the shift lever to change the speed of the unit.

Lift Lever (5): Use the lift lever to change the height of cut.

Parking Brake Lever (6): Use the parking brake lever to engage the brake when you leave the unit.

Throttle Control Lever (7): Use the throttle control lever to increase or decrease the speed of the engine. For models without a choke control button, the choke is regulated with the throttle control lever.

Choke Control Button (9): If equipped, use to start cold engine.

Grass Bagger Full Indicator (10): When you hear the audible alarm the grass bagger is full. Move the **blade rotation control (1)** to the DISENGAGE position to turn audible alarm off and see the "How To Empty The Grass Bagger" instructions in this section.

Attachments

This unit can use many different attachments. This unit can pull attachments like a lawn sweeper, a lawn aerator, or a hopper spreader. This unit can not use attachments that engage the ground like a plough, a disk harrow, or a cultivator.

For trailer and pull-behind attachments, the maximum weight is 113 kg (250 lbs.).

How To Use The Throttle Control (Figure 8)

Use the **throttle control (7)** to increase or decrease the speed of the engine.

1. The FAST position is marked with a detent. For normal operation and when using a grass bagger, move the throttle control to the FAST position. For maximum charging of the battery and for a cooler running engine, operate the engine in the FAST position.
2. The engine governor is set at the factory for maximum performance. Do not adjust the governor to increase the speed of the engine.

How To Use The Blade Rotation Control (Figure 8)

Use the **blade rotation control (1)** to engage the blade(s).

1. Before you start the engine, make sure the **blade rotation control (1)** is in the DISENGAGE position.
2. (Figure 11) Move the **blade rotation control (1)** to the ENGAGE position to rotate the blade(s).

F-000786J

NOTE: If the engine stops when you engage the blade(s), the seat switch is not activated or the bag is not closed properly. Make sure you sit in the middle of the seat.

3. Move the **blade rotation control (1)** to the DISENGAGE position to stop the blade(s). Before you leave the operator's position, make sure the blade(s) has stopped rotating.
4. Before you ride the unit across a sidewalk or a road, move the **blade rotation control (1)** to the DISENGAGE position.



WARNING: Always keep your hands and feet away from the blade, deflector opening, and the mower housing when the engine runs.

How To Use The Shift Lever (Figure 8)

To change the forward speed or the direction of the unit, follow the steps below.

CAUTION: Before you move the shift lever, completely push the clutch/brake pedal forward to stop the unit. If the unit is not stopped, the gearbox can be damaged.

1. Completely push the **clutch/brake pedal (2)** forward to stop the unit. Keep your foot on the pedal.
2. Move the **throttle control lever (3)** to the SLOW position.
3. To go forward, move the **shift lever (4)** to a forward speed setting. To go backward, move the **shift lever (4)** to reverse.
4. Slowly release the **clutch/brake pedal (2)**. Do not keep your foot on the pedal.
5. Move the **throttle control (7)** to the FAST position.

How To Use The Parking Brake (Figure 8)

1. Completely push the **clutch/brake pedal (2)** forward.
2. Lift the **parking brake lever (6)**.
3. Remove your foot from the **clutch/brake pedal (2)** and then release the **parking brake lever (6)**. Make sure the parking brake will hold the unit.
4. To release the **parking brake (6)**, completely push the **clutch/brake pedal (2)** forward. The parking brake will automatically release.



WARNING: Before you leave the operator's position, move the shift lever to the neutral (N) position. Set the parking brake. Move the blade rotation control to the DISENGAGE position. Stop the engine and remove the ignition key.

How To Change The Cutting Height (Figure 8)

To change the cutting height, raise or lower the lift lever (5) as follows.

1. Move the **lift lever (5)** forward to lower the mower housing and back to raise the mower housing.
2. When you ride on a sidewalk or road, move the **lift lever (5)** to the highest position and move the **blade rotation control (1)** to the DISENGAGE position.

How To Stop The Unit (Figure 8)

1. Completely push the **clutch/brake pedal (2)** forward to stop the unit. Keep your foot on the pedal.
2. Move the **blade rotation control (1)** to the DISENGAGE position.
3. Move the **shift lever (4)** to the NEUTRAL position.
4. Set the **parking brake (6)**.



WARNING: Make sure the parking brake will hold the unit.

5. Move the **throttle control (7)** to the SLOW position.
6. To stop the engine, turn the **ignition key (3)** to the OFF position. Remove the key.

How To Transport The Unit

To transport the unit, follow the steps below.

1. Move the blade rotation control to the DISENGAGE position.
2. Raise the lift lever to the highest position.
3. Move the throttle control to a position between SLOW and FAST.
4. To go faster, move the shift lever to a faster speed.

How To Operate With The Mower Housing

IMPORTANT: When you operate with the mower housing, always operate with the throttle control in the FAST position.

1. Start the engine.
2. Move the lift lever to a height of cut position. In high or thick grass, cut the grass in the highest position first and then lower the mower housing to a lower position.
3. Move the throttle control to the SLOW position.
4. Slowly move the blade rotation control to the ENGAGE position.
5. Push the **clutch/brake pedal** completely forward.
6. Move the shift lever to one of the speed settings.

NOTE: When you mow in heavy grass or mow with a bagger, put the shift lever in the slowest speed.

7. Slowly release the clutch/brake pedal.
8. Move the throttle control to the FAST position. If you need to go faster or slower, stop the unit and move the shift lever to another speed setting.
9. Make sure the level of cut is still correct. After you mow a short distance, look at the area that was cut. If the mower housing does not cut level, see the instructions on "How To Level The Mower Housing" in the Maintenance section.



WARNING: For better control of the unit, select a safe speed.

How To Operate On Hills



WARNING: Do not ride up or down slopes that are too steep to back straight up. Never ride the unit across a slope.

1. Before you ride up or down a hill, move the shift lever to the slowest speed.
2. Do not stop or change speed settings on a hill. If you must stop, quickly push the clutch/

brake pedal forward and set the parking brake.

3. To start again, make sure the shift lever is in the slowest speed. Move the throttle control to the SLOW position. Slowly release the pedal.
4. If you must stop or start on a hill, always have enough space for the unit to roll when you release the brake and engage the clutch.
5. Be very careful when you change directions on a hill. When on a slope or in a turn on a hill, move the throttle control to the SLOW position to help prevent an accident.



WARNING: Never store the grass bagger with grass clippings in the bags. Even a small amount of grass or debris can generate enough heat to start a fire.



WARNING: Do not operate unless the entire grass bagger attachment is in place.

How To Empty The Grass Bagger (Figure 33)

1. Move the blade rotation control to the DISENGAGED position.
2. While sitting on the seat, lift and pull the handle (1) forward to the DUMP position.
3. Drive slowly forward to allow the grass to fall out of the bag.
4. Push the handle rearward and down to the OPERATING position.

NOTE: If the engine stops when you engage the blade(s), the seat switch is not activated or the grass bagger is not locked in place.

Before Starting The Engine

Check the oil

NOTE: The engine was shipped from the factory filled with oil. Check the level of the oil. Add oil as needed. See the engine manufacturer's instructions for the type of petrol and oil to use.

1. Make sure the unit is level.

NOTE: Do not check the level of the oil while the engine runs.
2. Check the oil. Follow the procedure in the engine manufacturer's instructions.
3. If necessary, add oil until the oil reaches the FULL mark on the dipstick. The quantity of oil needed from ADD to FULL is shown on the dipstick. Do not add too much oil.

Add Petrol



WARNING: Always use a safety petrol container. Do not smoke when adding petrol to the fuel tank. Do not add petrol when you are inside an enclosure. Before you add petrol, stop the engine and let the engine cool for several minutes.

(Figure 9) Fill the fuel tank (1) to the FULL (2) position with regular unleaded petrol. Do not use premium unleaded petrol. Make sure the petrol is fresh and clean. Leaded petrol will increase deposits and shorten the life of the valves.

NOTE: Open fuel shut off valve 1/4 turn, if equipped.

F-000786J

How To Start The Engine



WARNING: The electrical system has an operator presence system that includes a sensor switch for the seat. These components tell the electrical system if the operator is sitting on the seat. This system will stop the engine when the operator leaves the seat if the blade rotation control is engaged or if the transmission is engaged. For your protection, always make sure this system operates correctly.

NOTE: The engine will not start unless you depress the clutch/brake pedal or engage the parking brake and move the blade rotation control to the DISENGAGE position.

1. Push the clutch/brake pedal completely forward. Keep your foot on the pedal.
2. Move the shift lever to the neutral (N) position.
3. Make sure the blade rotation control is in the DISENGAGE position.
4. Move the throttle control completely forward to the CHOKE or FAST position. Some models have a separate choke knob. Pull the choke knob to the full CHOKE position.
5. Turn the ignition key to the START position.

NOTE: If the engine does not start after four or five tries, move the throttle control to the FAST position. Again try to start the engine. If the engine will not start, see the TROUBLE SHOOTING CHART.
6. Slowly move the throttle control to the SLOW position.
7. To start a hot engine, move the throttle control to a position between FAST and SLOW.

Mowing And Bagging Tips

1. For a lawn to look better, check the cutting level of the mower housing. See "How To Level The Mower Housing" in the Maintenance section.
2. For the mower housing to cut level, make sure the tyres have the correct amount of air pressure.
3. Every time you use the unit, check the blade. If the blade is bent or damaged, immediately replace the blade. Also, make sure the nut for the blade is tight.
4. Keep the blade(s) sharpened. Worn blades will cause the ends of the grass to turn brown.
5. Do not cut or bag grass that is wet. Wet grass will not discharge correctly. Let the grass dry before cutting.
6. If the grass is very high, cut two times to decrease the load on the engine. First cut with the mower housing in the highest position and then lower the mower housing for the second cut.
7. Operate the engine with the throttle in FAST position and the shift lever in first or second gear.
8. After each use, clean the bottom and top of the mower housing for better performance. Also, a clean mower housing will help prevent a fire.

MAINTENANCE

NOTE: Illustrations and pictorials begin on page 2.

General Recommendations

1. The owner's responsibility is to maintain this product. This will extend the life of the product and is also necessary to maintain warranty coverage.
2. Check the spark plug, drive brake, lubricate the unit, and clean the air filter once a year.
3. Check the fasteners. Make sure all fasteners are tight.
4. Follow the Maintenance section to keep the unit in good operating condition.



WARNING: Before you make an inspection, adjustment, or repair to the unit, disconnect the wire to the spark plug. Remove the wire from the spark plug to prevent the engine from starting by accident.

NOTE: Torque is measured in foot pounds (metric Nm). This measurement describes how tight a nut or bolt must be. The torque is measured with a torque wrench.

Inspect Blade (Figure 10)



WARNING: Before you inspect or remove the blade, disconnect the wire to the spark plug. If the blade hits an object, stop the engine. Check the unit for damage. The blade has sharp edges. When you hold the blade, use gloves or cloth material to protect your hands.

If you keep the blade (1) sharp and inspect the blade for damage, the blade will cut better and be more safe to operate. Frequently check the blade for excessive wear, cracks, or other damage. Frequently check the nut (3) that holds the blade (1). Keep the nut (3) tight. If the blade hits an object, stop the engine. Disconnect the wire to the spark plug. See if the blade is bent or damaged. Check the blade adapter (5) for damage. Before you operate the unit, replace damaged parts with original equipment parts. See the authorized service centre in your area. Every three years, have an authorized service person inspect the blade or replace the old blade with an original equipment part.

How To Remove And Install The Blade (Figure 10)

1. Remove the mower housing. See the instructions on "How To Remove The Mower Housing".
2. Use a piece of wood to keep the blade from rotating.
3. Remove the nut (3) that holds the blade (1).
4. Check the blade (1) and the blade adapter (5) according to the instructions for "Inspect Blade". Replace a badly worn or damaged blade with an original equipment blade. See an authorized service centre in your area.
5. Clean the top and bottom of the mower housing. Remove all the grass and debris.
6. Mount the blade (1) and blade adapter (5) on the mandrel (6).
7. Mount the left and right blade (1) so that the hi-lift edges (7) are up. If the blade is upside down, the blade will not cut correctly and can cause an accident.
8. Fasten the blade (1) with the original washers (2,8) and nut (3). Make sure the outside rim of the Belleville washer (2) is against the blade (1).



WARNING: Always keep the nut (3) tight that holds the blade (1). A loose nut or blade can cause an accident.

9. Tighten the nut (3) that holds the blade (1) to a torque of 45 foot pounds (62 Nm).

10. Install the mower housing. See “How To Remove The Mower Housing”.

How To Adjust The Blade Rotation Control

WARNING: To prevent an injury, the blade rotation control must operate correctly.

In normal usage, the blade rotation control will not require an adjustment. However, if the cutting performance decreases or the quality of cut is poor, make the following changes.

1. When you mow, make sure the throttle control is in the FAST position.
2. (Figure 11) Move the blade rotation control to the DISENGAGE position (1).
3. Stop the engine. Disconnect the wire from the spark plug.
4. Check the blade(s). Keep a sharp edge on the blade(s). A blade that is not sharp will cause the tips of the grass to become brown.
5. (Figure 12) Disconnect the blade drive spring (2) from the blade control rod (1). Move the blade drive spring (2) to the middle hole (4). This will increase the tension on the mower drive belt.
6. Attach the wire to the spark plug. Mow for a short distance and again check the quality of cut. If necessary, move the blade drive spring (2) to the bottom hole (5)
7. Again check the quality of cut. If the quality of cut has not improved, replace the mower drive belt. See “How To Replace The Mower Drive Belt”. If the replacing the belt does not correct the problem, take the unit to an authorized service centre.
8. Move the blade rotation control to the DISENGAGE position. Stop the engine.
9. (Figure 15) Check the operation of the blade brake. Rotate the pulleys with your hand. Make sure the brake pads (12) are pressed tightly against the pulleys

WARNING: If the brake pads (12) do not press tightly against the pulleys, take the unit to an authorized service centre.

10. (Figure 11) Move the blade rotation control to the ENGAGE position (2).
11. (Figure 15) Check the pads for the blade brake (12). If the pads are excessively worn or damaged, replace the brake pad assemblies. Correct replacement parts and assistance are available from an authorized service centre.
12. Attach the wire to the spark plug. Mow for a short distance and again check the operation of the blade rotation control.
13. When you move the blade rotation control to the DISENGAGE position, all movement will stop within five seconds. If there is movement of the belt or the blades continue to rotate, engage and disengage the blade rotation control five times to remove any excess rubber from a new mower drive belt. If you need assistance, take the unit to an authorized service centre.
14. (Figure 12) If you replace the mower drive belt, move the blade drive spring (2) to the top hole (3).

F-000786J

How To Adjust The Shift Lever (Figure 13)

If the NEUTRAL position on the shift lever does not match neutral on the gearbox, adjust the shift lever as follows.

1. Stop the engine.
2. Disconnect the adjuster nut (2) from the shifter bracket (3).
3. Make sure the shift lever is in the NEUTRAL position.
4. Push the unit forward. Make sure the gearbox is in neutral.
5. To align the adjuster nut (2) with the hole in the shifter bracket (3), turn the adjuster nut (2).
6. Connect the adjuster nut (2) to the shifter bracket (3).
7. Make sure the NEUTRAL position on the shift lever matches neutral on the gearbox.

How To Check And Adjust The Clutch (Figure 14)

If the motion drive belt is loose, the clutch will slip when; going up a hill, pulling a heavy load, or the unit will not move forward. Adjust the clutch as follows.

WARNING: Before you make an inspection, adjustment, or repair to the unit, disconnect the wire to the spark plug. Remove the wire from the spark plug to prevent the engine from starting by accident.

1. (Figure 25) Check the routing of the motion drive belt. Make sure the belt is installed correctly and is inside all the belt guides.
2. (Figure 14) Disconnect the adjustable nut (1) from the motion drive idler assembly (2).
3. Pull the clutch rod (3) until tight. Turn the adjustable nut (1) until the nut will fit through the hole in the motion drive idler assembly (2).
4. Remove the adjustable nut (1) from the hole. To lengthen the clutch rod (3), rotate the adjustable nut (1) 3 to 4 turns counter-clockwise.
5. Assemble the adjustable nut (1) to the motion drive idler assembly (2).
6. If the belt still slips after the clutch has been adjusted, then the motion drive belt is worn or damaged and must be replaced. See “How To Replace The Motion Drive Belt”.

How To Check And Adjust The Drive Brake (Figure 17)

Completely push the clutch/brake pedal forward. Set the parking brake. Move the shift lever to the neutral (N) position. Push the unit. If the rear wheels rotate, adjust or replace the brake pads. Adjust the drive brake (1) as follows.

1. The location of the drive brake (1) is on the side of the gearbox (3).
2. Make sure the parking brake is set and the shift lever is in neutral (N). Turn the hex nut (2) in a clockwise direction until the rear wheels do not turn when the unit is pushed forward.
3. Release the parking brake and push the unit. If the unit does not roll, turn the hex nut (2) in a counter-clockwise direction until the unit rolls.
4. Set the parking brake. Push the unit. If the rear wheels do not turn, the drive brake (1)

is correctly adjusted. Release the parking brake.

WARNING: If you cannot correctly adjust the drive brake, replace the brake pads. Correct replacement parts and assistance are available from an authorized service centre.

How To Remove The Battery (Figure 6)

To charge or clean the battery (1), remove the battery (1) from the unit as follows.

WARNING: To prevent sparks, disconnect the black battery cable (8) from the negative (-) terminal before you disconnect the red cable (5).

WARNING: The battery contains sulphuric acid which is harmful to the skin, eyes and clothing. If the acid gets on the body or clothing, wash with water.

1. Remove the battery cover (3).
2. Remove the fasteners (9) from the battery brackets (10,11).
3. Apply pressure to the left hand battery bracket (10) and remove bracket from frame (12) as shown.
4. Remove the right hand battery bracket (11).
5. Disconnect the black cable (8) from the negative (-) terminal.
6. Disconnect the red cable (5) from the positive (+) terminal (4).
7. Lift the battery (1) out of the unit.

How To Charge The Battery (Figure 6)

WARNING: When you charge the battery, do not smoke. Keep the battery away from any sparks. The fumes from the battery acid can cause an explosion.

1. Before you charge the battery (1), remove the battery (1).
2. To charge the battery (1), use a 12 volt battery charger. Charge at a rate of 6 amperes for 1 hour.
3. Install the battery (1).
4. Fasten the red cable (5) to the positive (+) terminal (4) with the fasteners as shown. Slide the terminal cover (2) over the positive terminal (4).
5. Fasten the black cable (8) to the negative (-) terminal with the fasteners as shown.

How To Level The Mower Housing (Figure 18 and Figure 19)

If the mower housing is level, the blade will cut easier and the lawn will look better.

WARNING: Before you make an inspection, adjustment, or repair to the unit, disconnect the wire to the spark plug. Remove the spark plug wire to prevent the engine from starting by accident

1. Make sure the unit is on a hard flat surface.

2. Check the air pressure in the tyres. If the air pressure is incorrect, the mower housing will not cut level. The correct air pressure is: Front Tyres 1,38 BAR (20 PSI), Rear Tyres 0,97 BAR (14 PSI).
3. If equipped, remove the gauge wheels.
4. **(Figure 18)** Move the **lift lever (1)** to the **level adjustment position (2)**.



WARNING: The lifter lever (1) is spring loaded. Make sure the lift lever (1) is locked in the level adjustment position (2).

5. **(Figure 19)** Loosen the left and right **adjuster knobs (1)**. Push down on each side of the mower housing. Make sure both sides of the mower housing are setting on a flat surface. Also, make sure the **lift links (2)** are loose and can easily move up or down
6. Push down on the **lift links (2)** and tighten the left and right **adjuster knobs (1)**. If necessary, use a wrench to tighten the **adjuster knobs (1)**
7. **(Figure 18)** Raise the **lift lever (1)**.
8. If equipped, attach the gauge wheels.
9. Mow for a short distance. If the height of cut is not level, repeat the above steps.

Where To Lubricate (Figure 16)



Models with grease fittings:
Lubricate with grease gun.
Apply grease with a brush to the areas shown.
Lubricate the areas shown with engine oil.

NOTE: Apply grease to the steering gear assembly.

CAUTION: If the unit is operated in dry areas that have sand, use a dry graphite spray to lubricate the unit.

Check The Tyres

Check the air pressure in the tyres. Tyres with too much air pressure will cause the unit to ride rough. Also, the wrong air pressure will keep the mower housing from cutting level. The correct air pressure is: Front Tyres 1,38 BAR (20 PSI), Rear Tyres 0,97 BAR (14 PSI).

How To Replace The Motion Drive Belt

1. Remove the mower housing. See the instructions on "How To Remove The Mower Housing".
2. **(Figure 21)** Remove the **screws (1)** that hold each side of the **middle discharge chute (2)**. Remove the **middle discharge chute (2)**.
3. **(Figure 20)** Disconnect the **belt tension spring (1)**.
4. **(Figure 25)** Remove the three **idler pulleys (2)**.
5. **(Figure 20)** Remove the **adjuster nut (3)** from the **idler bracket (4)**.
6. **(Figure 22)** Remove the three **screws (1)** from the **transaxle shield (2)**. Place the **transaxle shield (2)** in the **tunnel (3)**. The **bag full indicator (4)** wire harness will limit the **transaxle shield (2)** movement.
7. **(Figure 23)** Loosen the **belt guide (1)** at the **drive pulley (3)**.

8. Remove the **motion drive belt (4)** from the **drive pulley (3)**.
9. **(Figure 24)** To remove the **motion drive belt (1)** from the **stack pulley (2)**, pull the front end of the belt under the **stack pulley (2)** and then back between the stack pulley and the **steering plate (3)**.
10. Remove the motion drive belt. A correct replacement part or assistance is available from an Authorized Service Centre in your area.
11. To install the motion drive belt, reverse the above steps.
12. **(Figure 25)** Check the routing of the **motion drive belt (1)**. Make sure the motion drive belt is installed correctly on the **idler pulleys**.

How To Replace The Mower Drive Belts (Figure 15)

1. Remove the mower housing. See the instructions on "How To Remove The Mower Housing".
2. Loosen and pull the **belt retainer (1)** away from the **double idler pulley (2)**. Remove the **primary mower drive belt (3)** from the **double idler pulley (2)**.
3. Pull the **belt retainers (4)** away from the **single idler pulley (5)**. Remove the **primary mower drive belt (3)** from the **single idler pulley (5)**.
4. To release tension on the secondary belt, remove the **spring (8)** from the **double idler mount (9)**.
5. Remove the **secondary mower drive belt (10)** from the **double idler pulley (2)** and from the **right mandrel pulley (11)**.
6. A correct replacement part or assistance is available from an Authorized Service Centre in your area.
7. To install the mower drive belt, reverse the above steps.

How To Remove The Mower Housing (Figure 36)

1. Move the **blade rotation control (1)** to the **DISENGAGE** position.
2. Move the **lift lever (2)** to the level adjustment position.
3. Remove the hair pins and the washers from the **adjuster arms (3)**. See illustrations "C" and "D".
4. Remove the hair pins and washers from the **suspension links (4)**. See illustrations "A" and "B".
5. Disconnect the **extension spring (5)** from the **blade control rod (6)**. See illustration "E".
6. Disconnect the **front hanger (9)** from the axle support. See illustration "F".
NOTE: The hanger rod (11) is made with a bend.
7. Remove the **mower drive belt (7)** from the **stack pulley (8)**. See illustration "G".
8. Disconnect the **middle discharge chute (10)** from the mower housing. See illustration "H".
9. Pull the mower housing away from the right side of the unit.
10. To install the mower housing, reverse the above steps.

11. Check belt routing of the **primary mower drive belt (1)** and the **secondary mower drive belt (2)**. See illustration "J".

How To Replace The Fuse (Figure 34)

If the fuse is blown, the engine will not start. Remove the fuse and replace with a 15 amp. automotive fuse. To easily access the **fuse (2)**. Remove the **access panel (1)** on the console as shown.

Storage (over 30 days)

At the end of each year, prepare the unit for storage as follows.

1. Drain the fuel from the carburettor and the fuel tank. Change the engine oil. See the engine manufacturer's instructions.
2. Clean the entire unit.
3. Charge the battery.
4. To remove Grass Bagger for storage.
 - a. **(Figure 33)** Put the grass bagger in the **DUMP** position.
 - b. **(Figure 35)** Hold **rear handle (1)** and lift the **release handle (2)**.
 - c. Slowly lower bagger to ground.
 - d. Lift grass bagger away from the tractor.



WARNING: Never store the grass bagger with grass clippings in the bags. Even a small amount of grass or debris can generate enough heat to start a fire.



WARNING: Do not operate unless the entire grass bagger attachment is in place.

How To Order Replacement Parts

The replacement parts are shown either on the back pages of this Instruction Book or in a separate Parts List Book.

Use only manufacturer's authorized or approved replacement parts. The letter placed on the end of the part number denotes the type of finish for the part, C for chrome, Z for zinc, a PA for purchased assembly. It is important that you include this when ordering a part. Do not use attachments or accessories not specifically recommended for this unit. In order to obtain proper replacement parts you must supply the model number of your mower (see nameplate).

Replacement parts, except for the engine, transmission, transaxle or differential, are available from the store where the mower was purchased or a service shop recommended by the store.

If you are unable to obtain parts or service in the manner outlined above, then contact:

HAYTER LIMITED, Service Department, Spellbrook, Bishop's Stortford, Hertfordshire. CM23 4BU.

UK ONLY: Details of your local Hayter authorised dealer are contained in Yellow Pages or contact: Freephone 0800 616298.

Replacement parts for the engine, transaxle, or transmission, are available from the manufacturer's authorized service centre found in the commercial pages of the telephone directory. Also, see the individual engine or transmission warranties to order replacement parts.

When ordering the following information is required:

- (1) The Model Number
- (2) Serial Number
- (3) Part Number
- (4) Quantity

TROUBLE SHOOTING CHART

PROBLEM: The engine will not start.

1. Follow the steps, "How To Start The Engine" in this book.
2. Electric-Start Models: Clean the battery terminals. Tighten the cables.
3. Check for a loose wire. Tighten the limit switches. (See the wiring diagram.)
4. Drain the fuel tank. Clean the fuel line. Replace the fuel filter.
5. Remove the spark plug(s). Move the throttle to the SLOW position. Turn the ignition key to the ON position. Try to start the engine several times. Install the spark plug.
6. Replace the spark plug.
7. Adjust the carburettor.

PROBLEM: The engine will not turn over.

1. Follow the steps, "How To Start The Engine" in this book.
2. Electric-Start Models: Check the level of the acid in the battery. If needed, add water. Charge the battery.
3. Replace the fuse.
4. Check the wiring harness for damage or a loose connection. Repair the damaged wire.
5. Electric-Start Models: replace the solenoid. Recoil-Start Models: replace the module.

PROBLEM: The engine is difficult to start.

1. Adjust the carburettor.
2. Replace the spark plug.
3. Replace the fuel filter.

PROBLEM: The engine does not run smooth or has a loss of power.

1. Check the oil.
2. Clean the air filter.
3. Clean the air screen.
4. Replace the spark plug.
5. The engine is working too hard. Use a slower speed.
6. Adjust the carburettor.
7. Replace the fuel filter.

PROBLEM: The engine does not run smooth at fast speed.

1. Replace the spark plug.

2. Adjust the throttle control.
3. Clean the air filter.
4. Replace the fuel filter.

PROBLEM: The engine stops when the blades are engaged.

1. To activate the seat sensor, always sit in the middle of the seat.
2. Check the wiring harness for damage or a loose connection. Repair the damaged wire.
3. Grass Bagger not closed properly. (only applies to rear grass baggers.)

PROBLEM: On slopes, the engine stops.

1. Mow up and down slopes. Never mow across a slope.
2. To activate the seat sensor, always sit in the middle of the seat.

PROBLEM: The engine will not idle.

1. Replace the spark plug.
2. Clean the air filter.
3. Adjust the carburettor.
4. Adjust the throttle control.
5. Drain the fuel tank. Clean the fuel line. Replace the fuel filter.

PROBLEM: A hot engine causes a decrease in power.

1. Clean the air screen.
2. Check the oil.
3. Adjust the carburettor.
4. Replace the fuel filter.

PROBLEM: Excessive vibration.

1. Replace the blade.
2. Check for loose engine bolts.
3. Decrease the air pressure in the tyres.
4. Adjust the carburettor.
5. Check for a damaged belt or damaged pulley. Replace the damaged parts.

PROBLEM: The grass does not discharge correctly.

1. Stop the engine. Clean the mower housing.
2. Raise the height of cut.
3. Replace or sharpen the blade(s).
4. Move the shift lever to a slower speed.

5. Move the throttle control to the FAST position.
6. Replace the spring for the blade idler.

PROBLEM: The mower housing does not cut level.

1. Check the air pressure in the tyres.
2. Adjust the level of the mower housing.
3. Check the front axle. If the front axle does not freely pivot, loosen the axle bolt(s).

PROBLEM: The mower blades will not rotate.

1. Check the mower drive belt. Make sure the belt is installed correctly.
2. Replace the mower drive belt.

PROBLEM: The unit will not move when the clutch is engaged.

1. Check the motion drive belt. Make sure the belt is installed correctly.
2. Adjust the clutch.
3. Replace the motion drive belt.

PROBLEM: The unit moves slower or stops when the clutch is engaged.

1. Adjust the clutch.
2. Replace the motion drive belt.

PROBLEM: When the clutch/brake pedal is released, belt noise can be heard.

1. Temporary belt noise does not change the operation of the unit. If belt noise is continuous, check the routing of the belt. Make sure the belt is inside all belt guides.
2. If the noise is continuous, adjust the clutch.

PROBLEM: The rear wheels spin over uneven terrain.

1. Check the front axle. If the front axle does not freely pivot, loosen the axle bolt(s).

PROBLEM: The transaxle is difficult to shift between gears with the engine running and the clutch depressed.

1. Check the clutch adjustment to make sure the belt stops when the clutch pedal is depressed with the transaxle in (N) neutral.
2. Check the belt guides around the transaxle drive pulley. Make sure the belt guides do not touch the pulley.

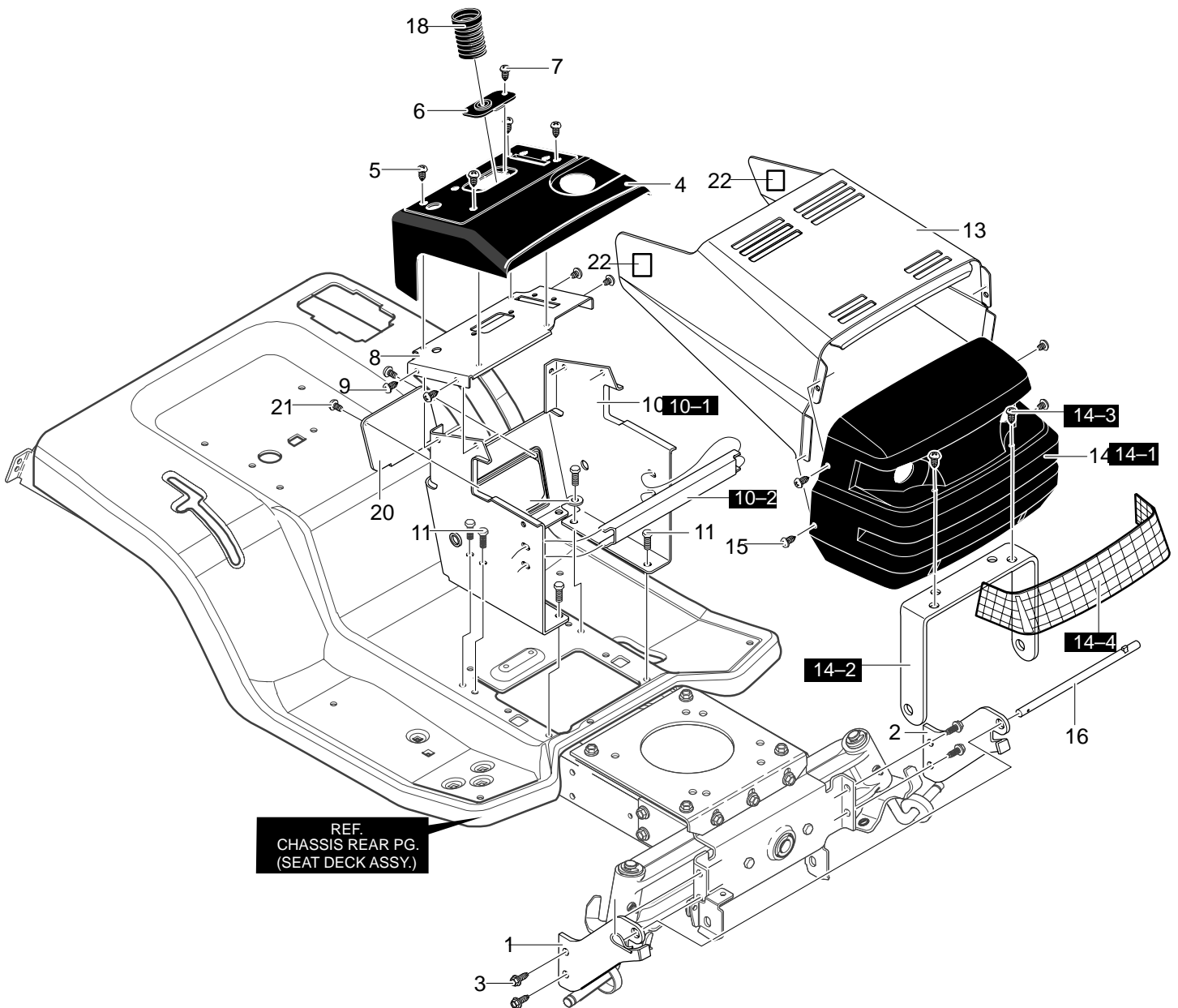

CODE144S

REPAIR PARTS CHASSIS & HOOD ASSEMBLY

Key No.	Description	Part No.	Key No.	Description	Part No.
1	Bracket, Grille RH	MU690543-853	14	Grille Assy.	MU92350
2	Bracket, Grille LH	MU690544-853	15	Screw	MU711629
3	Screw, 5/16-18x.75	MU711606	16	Rod, Hood Pivot	MU690093
4	Dash	MU94842	17	Hair Pin	MU711676
5	Screw, 10-24x.500	MU711629	18	Bellows, Steering	MU054789
6	Bearing, for Dash	MU94214	19	Washer, Bel	MU712063
7	Screw, 1/4-14x.75	MU711762	20	Panel, Access	MU95366-848
8	Dash Panel Plate	MU94211-853	21	Screw 10-24x.500	MU710196
9	Screw, 10-24x.500	MU711629	22	Adhesive Pad	MU318197
10	Asm., Lwr Console Suppt	MU690104-848		Decal, Hayters 13/40 RH	MU712182
11	Screw, 5/16-18x.75	MU711606		Decal, Hayters 13/40 LH	MU712181
13	Hood	MU94972-848	—	Instruction Book & Parts List	F-000786J

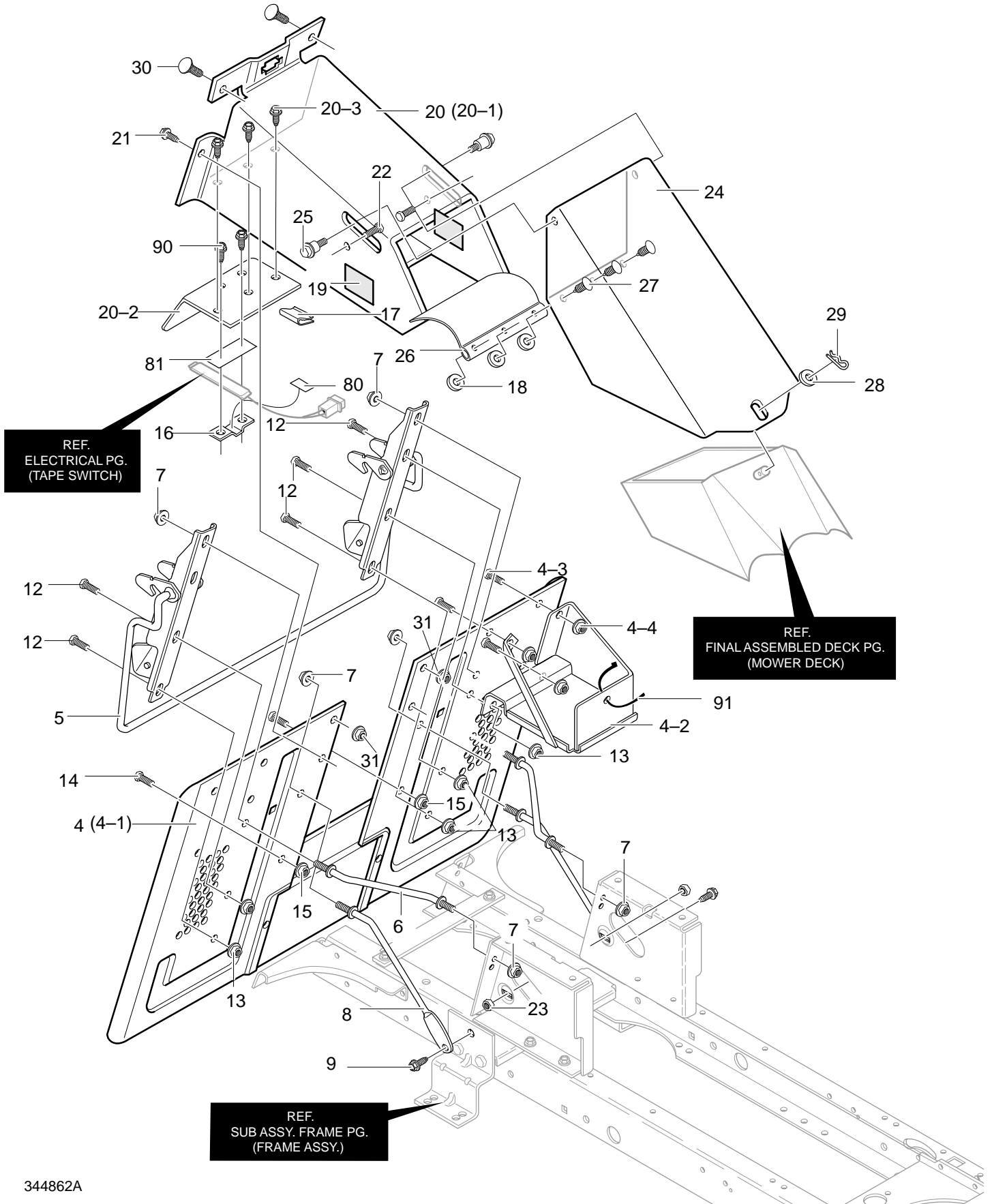

CODE144S

REPAIR PARTS REAR CHASSIS ASSEMBLY

Key No.	Description	Part No.	Key No.	Description	Part No.
4	Assy., Back Plate/Battery	MU343678-853	20-1	Chute Weld Asm. Upper	MU94350
4-1	Assy. Back Plate Flat	MU95162	20-2	Shield, Transaxle	MU95367
4-2	Battery Tray Assembly	MU94563	20-3	Screw, 1/4-20x.63	MU711642
4-3	Screw, 5/16-18x.50	MU180073	21	Screw, 5/16-18x.75	MU711606
4-4	Nut, 5/16-18 Hexwdfllk Whiz	MU45174	22	Bolt, Carriage 5/16-18x.75	MU340720
5	Weldment-Latch Lever	MU95359-853	23	Nut, 5/16-18	MU710026
6	Rod, Brace	MU690097	24	Middle Chute Assembly	MU94296-853
7	Nut, 3/8-16 Hwdfll Whiz-lock	MU711906	25	Shoulder Bolt	MU009x57
8	Rod, Brace	MU94231	26	Flap, Chute	MU94264
9	Screw, 5/16-18x.75	MU711606	27	Fastener, Ratchet	MU309235
12	Screw, 5/16-18x.75	MU9357	28	Flatwasher	MU711617
13	Nut, 5/16-18 Hexwdfllk Whiz	MU710026	29	Pin, Hair	MU711682
14	Screw, 5/16-18x.75	MU711606	30	Bolt, Carriage 5/16-18x.75	MU340720
15	Nut, 5/16-18 Hexwdfllk Whiz	MU710026	31	Nut, 5/16-18	MU710026
16	Bracket, Flex Switch Mounting	MU690245	80	Tape, Double Sided Foam 3/4"	MU712009
17	Wire Clip, Adhesive	MU55939	81	Tape, Double Sided Foam 3/4"	MU712009
18	Flatwasher	MU711666	90	Screw, 1/4-20x.63	MU711642
19	Pad, Adhesive	MU318197	91	Cable Tie	MU57444
20	Asm., T/A Shield & Upper Chute	MU690102-853			

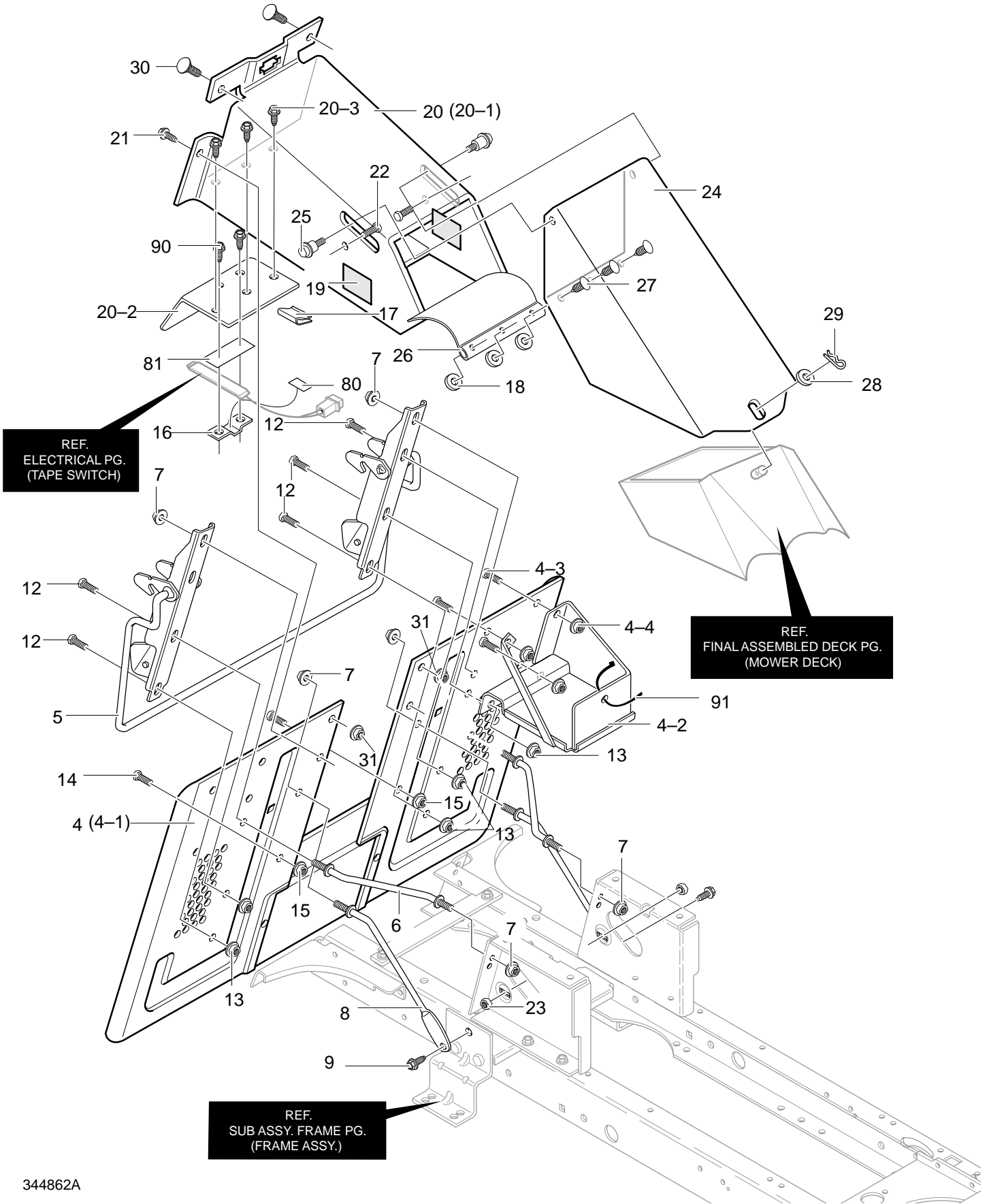

CODE144S

REPAIR PARTS REAR CHASSIS ASSEMBLY

Key No.	Description	Part No.	Key No.	Description	Part No.
4	Assy., Back Plate/Battery	MU343678-853	20	T/A Shield & Upper Chute Assy	MU690102-853
4-1	Assy. Back Plate Flat	MU95162	20-1	Chute Weld Asm. Upper	MU94350
4-2	Battery Tray Assembly	MU94563	20-2	Shield, Transaxle	MU95367
4-3	Screw, 5/16-18x.50	MU180073	20-3	Screw, 1/4-20x.63	MU711642
4-4	Nut, 5/16-18 Hexwdfllk Whiz	MU45174	21	Screw, 5/16-18x.75	MU711606
5	Weldment-Latch Lever	MU95359-853	22	Bolt, Carriage 5/16-18x.75	MU340720
6	Rod, Brace	MU690097	23	Nut, 5/16-18	MU710026
7	Nut, 3/8-16 Hwdfll Whiz-lock	MU711906	24	Middle Chute Assembly	MU94296-853
8	Rod, Brace	MU94231	25	Shoulder Bolt	MU009x57
9	Screw, 5/16-18x.75	MU711606	26	Flap, Chute	MU94264
12	Screw, 5/16-18x.75	MU9357	27	Fastener, Ratchet	MU309235
13	Nut, 5/16-18 Hexwdfllk Whiz	MU710026	29	Pin, Hair	MU711682
14	Screw, 5/16-18x.75	MU711606	30	Bolt, Carriage 5/16-18x.75	MU340720
15	Nut, 5/16-18 Hexwdfllk Whiz	MU710026	31	Nut, 5/16-18	MU710026
16	Bracket, Flex Switch Mounting	MU690245	80	Tape, Double Sided Foam 3/4"	MU712009
17	Wire Clip, Adhesive	MU55939	81	Tape, Double Sided Foam 3/4"	MU712009
18	Flatwasher	MU711666	90	Screw, 1/4-20x.63	MU711642
19	Pad, Adhesive	MU318197	91	Cable Tie	MU57444

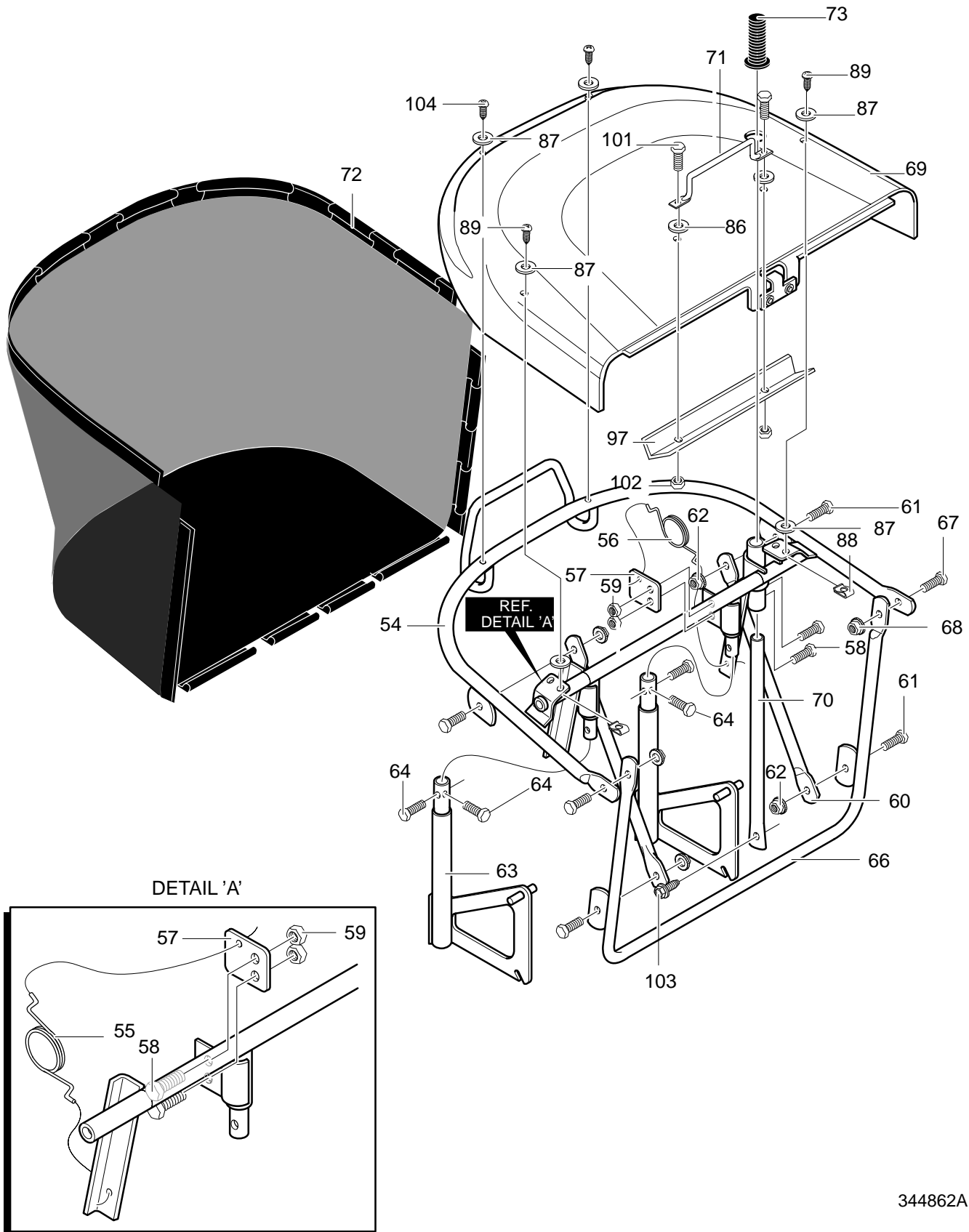

344862A

CODE144S

REPAIR PARTS GRASS BAGGER ASSEMBLY

Key No.	Description	Part No.	Key No.	Description	Part No.
54	Asm. Weld Upper Frame	MU690044-853	69	Top Collector Assembly	MU94908-848
55	Spring, Torsion RH	MU690003	70	Handle, Dump Collector	MU690019
56	Spring, Torsion LH	MU690004	71	Handle, Reba Collector	MU690506-853
57	Bracket, Spring Collector	MU95339-853	72	Reba Collector Bag	MU95389
58	Screw, 1/4-20x.50	MU313686	73	Rubber Grip	MU94854
59	Nut, 1/4-20	MU73826	86	Washer	MU712129
60	Brace, Frame Collector	MU94850-853	87	Washer	MU711921
61	Screw, 1/4-20x.62	MU711909	88	Nut, 1/4-20 Tinnerman	MU578107
62	Nut, 1/4-20	MU711632	89	Screw, 1/4-20x.63	MU711674
63	Asm. Support Collector	MU95343-853	97	Brace, Bagger	MU690010-853
64	Screw, 1/4-20x1.50	MU711653	101	Screw, 1/4-20x1.50	MU712068
66	Asm. Front Frame Collect	MU95349-853	102	Nut, 1/4-20	MU711632
67	Screw, 1/4-20x.62	MU711909	103	Screw, #12x.50	MU711741
68	Nut, 1/4-20	MU711632	104	Screw, #12x.50	MU711741

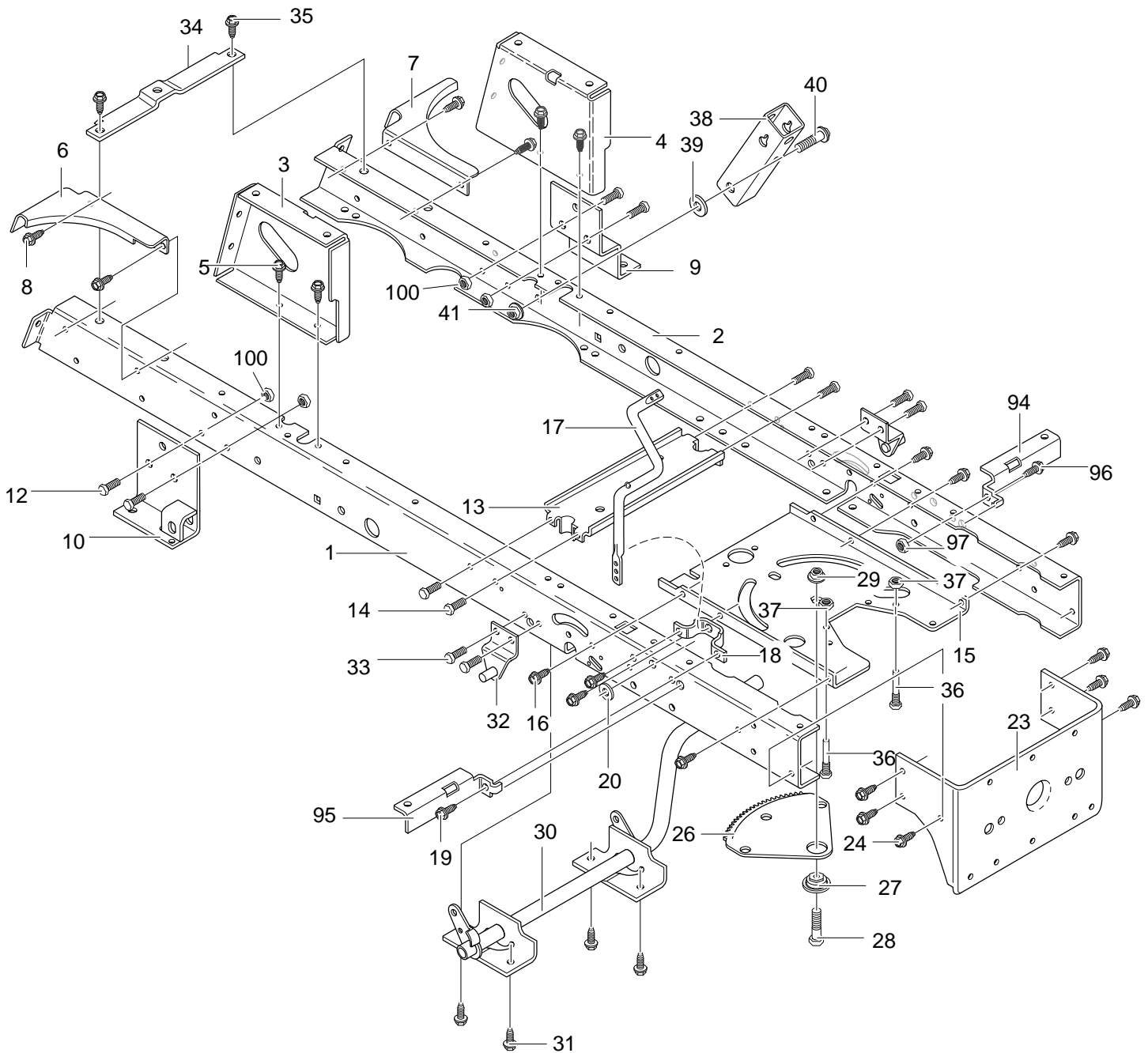

CODE144S

REPAIR PARTS FRAME ASSEMBLY

Key No.	Description	Part No.	Key No.	Description	Part No.
1	Frame, Rail RH	MU94564	26	Gear, Sector	MU94121
2	Frame, Rail LH	MU94565	27	Bearing, Sector Gear	MU94123
3	Support, Seat RH	MU94634	28	Screw, 5/16-18x1.00	MU001X84
4	Support, Seat LH	MU94633	29	Nut, 5/16-18	MU15X113
5	Screw, .312-18x.75	MU26X249	30	Clutch/Brake Pedal	MU94241
6	Brace, BackPlate RH	MU94561	31	Screw, .312-18x.75	MU26X249
7	Brace, BackPlate LH	MU94562	32	Bracket, Suspension Asm.	MU94285
8	Screw, 5.312-18x.75	MU26X249	33	Screw, .312-18x.75	MU26X249
9	Bracket, T/A RH VST LH MST	MU94234	34	Brace, Rail	MU94566
10	Assy., Shift Brace	MU95396	35	Screw, .312-18x.75	MU26X249
12	Screw, .312-18x.75	MU26X249	36	Zinc Screw Guide	MU93349
13	Assy., Idler Mount, Front	MU94237	37	Nut, 5/16-18	MU015X79
14	Screw, .312-18x.75	MU26X249	38	Bracket, Pivot	MU94015
15	Plate, Steering	MU1001024	39	Washer, Flat	MU845
16	Screw, .312-18x.75	MU26X249	40	Bolt, Shoulder 3/8-16	MU009X53
17	Crank, PTO	MU690394	41	Nut, 3/8-16	MU015X84
18	Bracket, Bell Crank	MU94005	94	Bracket, Seat Deck LH	MU690036
19	Screw, .312-18x.75	MU26X249	95	Bracket, Seat Deck RH	MU690035
20	Washer, Flat	MU120395	96	Screw, .312-18x.75	MU26X249
23	Bracket, Hanger Rear	MU94013	97	Nut, 5/16-18	MU015X79
24	Screw, .312-18x.75	MU26X249	100	Nut, 5/16-18	MU015X88

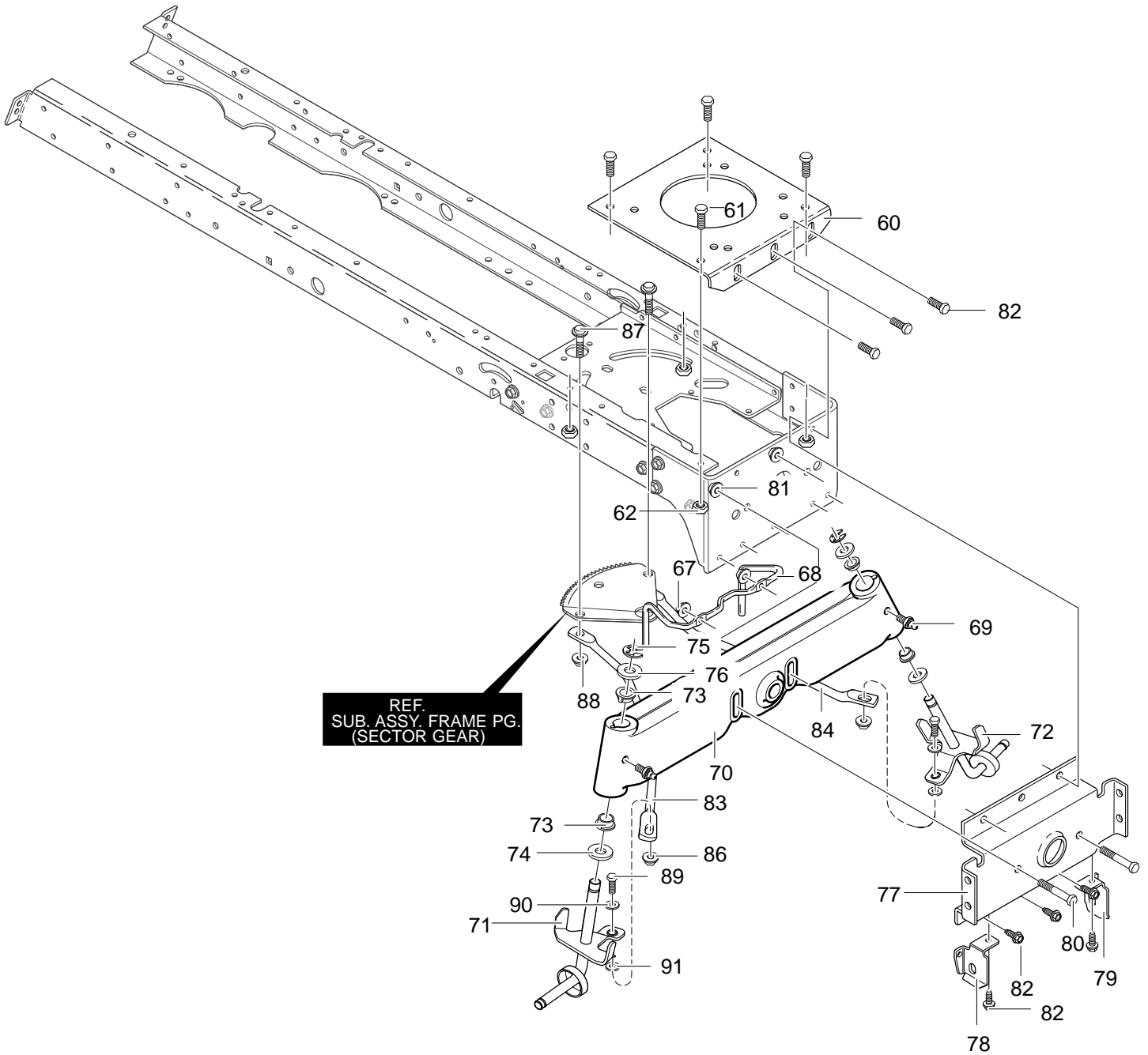

CODE144S

REPAIR PARTS FRAME ASSEMBLY

Key No.	Description	Part No.	Key No.	Description	Part No.
60	Engine Plate	MU94006	78	Hanger, Deck RH	MU690199
61	Screw, .312-18x.75	MU26X249	79	Hanger, Deck LH	MU690198
62	Nut, 5/16-18	MU015X88	80	Screw, 5/16-18x3.00	MU180113
67	Nut, 5/16-18	MU015X79	81	Nut, 5/16-18	MU015X88
68	Guide-Stack Pulley Belt	MU94310	82	Screw, .312-18x.75	MU26X249
69	Zerk, Grease	MU706	83	Drag Link, RH	MU95328
70	Axle, Cast Machined	MU95405	84	Drag Link, LH	MU95329
71	Spindle, Long RH	MU95182	86	Nut, 3/8-16	MU015X84
72	Spindle, Long LH	MU95183	87	Shoulder Bolt	MU9X57
73	Bearing, Spindle	MU92527	88	Nut, 3/8-16	MU015X84
74	Washer, .766IDx1.62ID	MU17X113	89	Screw, 3/8-16x1.50	MU01X111
75	E-Ring	MU0011X3	90	Flatwasher	MU17X104
76	Washer, Flat	MU17X195	91	Flatwasher	MU017X53
77	Hanger, Axle	MU94007			

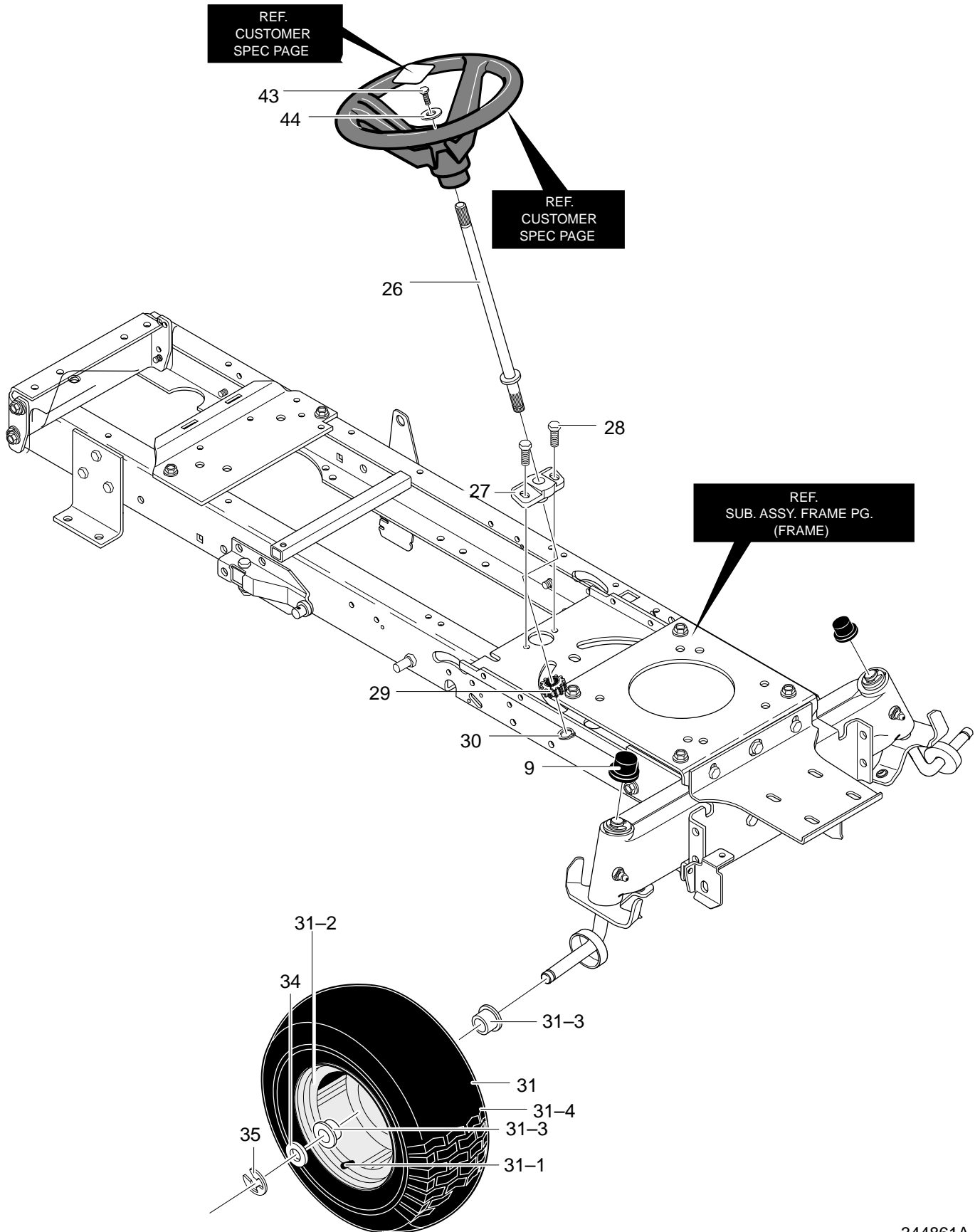

344861A

Key No.	Description	Part No.
9	Dust Hub Cap	MU094618
26	Shaft, Steering	MU94520
27	Bearing—Lower	MU94124
28	Screw, 5/16—18x.75	MU711606
29	Gear, Pinion	MU94122
30	Retaining Ring	MU710102
31	Tire & Rim	MU690049
31-1	Valve Stem	MU338512
31-2	Rim	MU338517
31-3	Bearing	MU338513
31-4	Tire	MU338516
34	Flatwasher	MU711758
35	E—Ring	MU0011X3
43	Screw, 1/4—20x.75	MU711719
44	Flatwasher	MU711663
—	Hub Cap	MU094618

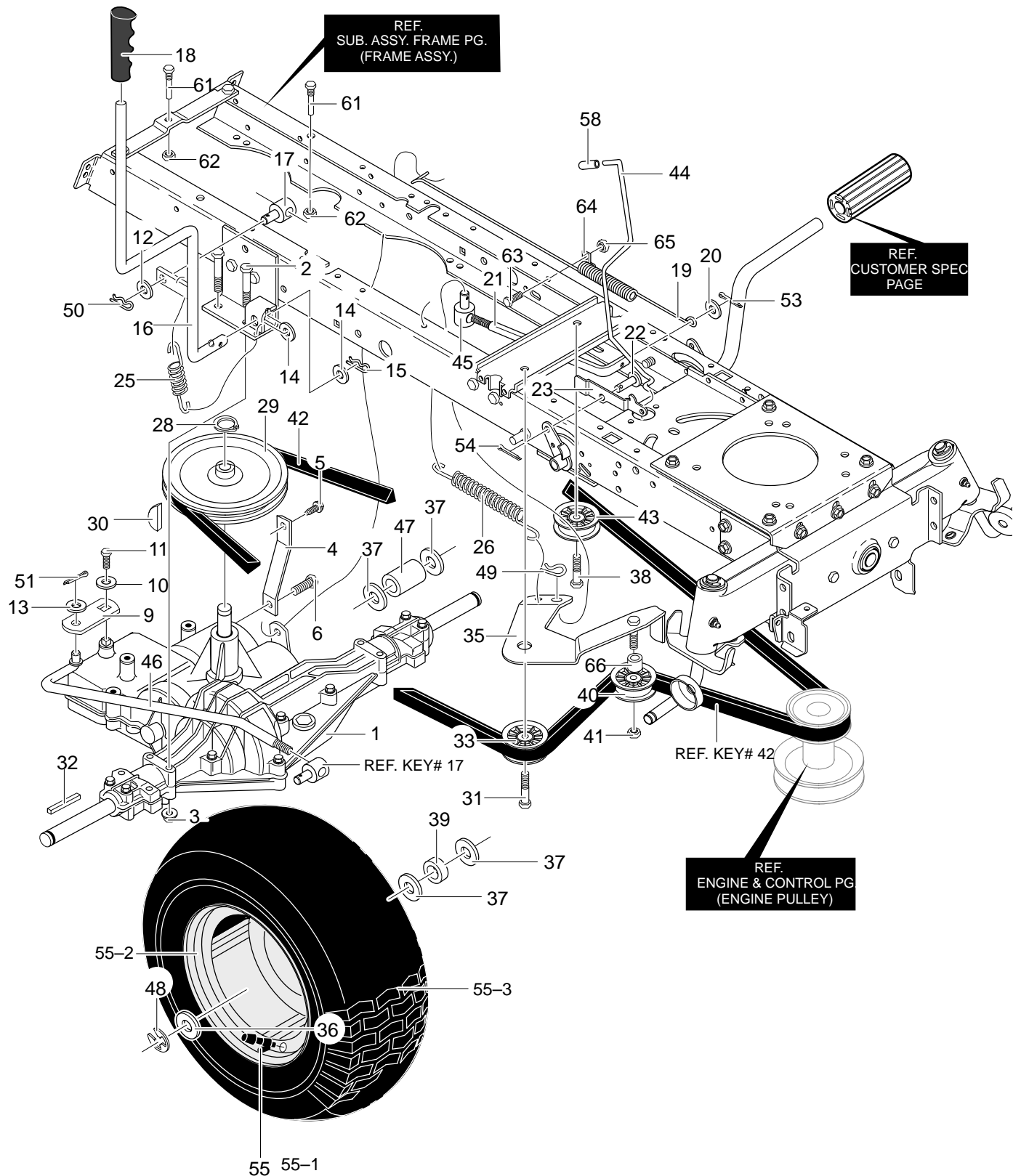

CODE144S

REPAIR PARTS MOTION DRIVE

Key No.	Description	Part No.	Key No.	Description	Part No.
1	Transaxle, MST206	*	36	Washer, Flat	MU711758
2	Screw, 5/16–18X2.50	MU711669	37	Washer, Flat	MU711904
3	Nut, 5/16–18	MU711634	38	Screw, 3/8–16x1.25	MU711905
4	Bracket, Stabilizer	MU94620–853	39	Spacer	MU95418
5	Screw, 5/16–18x.75	MU711606	40	Pulley, Idler	MU690409
6	Screw, 5/16–18x.75	MU710268	41	Nut, 3/8–16	MU711920
9	Bracket, Shift	MU94227	42	Belt, V 4L 114.12	MU94608
10	Washer, Transaxle	MU711895	43	Pulley, Idler	MU1001065
11	Screw, 1/4–28x.750	MU01X145	44	Park Brake Control Rod	MU690047
12	Washer, Flat	MU583409	45	Nut, 5/16–18 Adjusting	MU711898
13	Washer	MU71072	46	Rod, Shift Link	MU690027
14	Flatwasher	MU711894	47	Spacer	MU95419
15	Hair Pin	MU711899	48	E–Ring	MU0011X3
16	Shift Lever	MU690087	49	Pin, Hair	MU711659
17	Nut, Adjust	MU711591	50	Pin, Hair	MU711682
18	Grip	MU94497	51	Pin, Cotter	MU71081
19	Spring, Brake	MU95424	53	Pin, Cotter	MU71081
20	Washer, Flat	MU711921	54	Pin, Cotter	MU71081
21	Rod, Clutch	MU690016	55	Tire & Rim	MU692290
22	Pin, Clevis	MU711903	55–1	Valve Stem	MU338512
23	Latch, Park Brake	MU95290	55–2	Rim	MU338524
25	Spring	MU782223	55–3	Tire	MU338526
26	Spring, Tension	MU711522	58	Cap, Dump	MU335980
28	Ring, Ret	MU0011X7	61	Screw Guide	MU20619
29	Pulley, 9.0 ODV4L	MU94571	62	Nut, 1/4–20	MU710026
30	Key, Hi Pro 606	MU50795	63	Screw, 1/4–20x.50	MU313686
31	Screw, 3/8–16x1.25	MU711905	64	Retainer	MU711742
32	Key, Square	MU52928	65	Nut, 1/4–20	MU780285
33	Pulley, Idler	MU95531	66	Spacer 1/2 to 17MM	MU690369
35	Assy, Idler Arm Traction	MU94238–853	—	Hubcap	MU094618

* Contact your nearest transaxle dealer for parts and service.

For information on Replacement Parts see the Central Parts Distributor in your area.

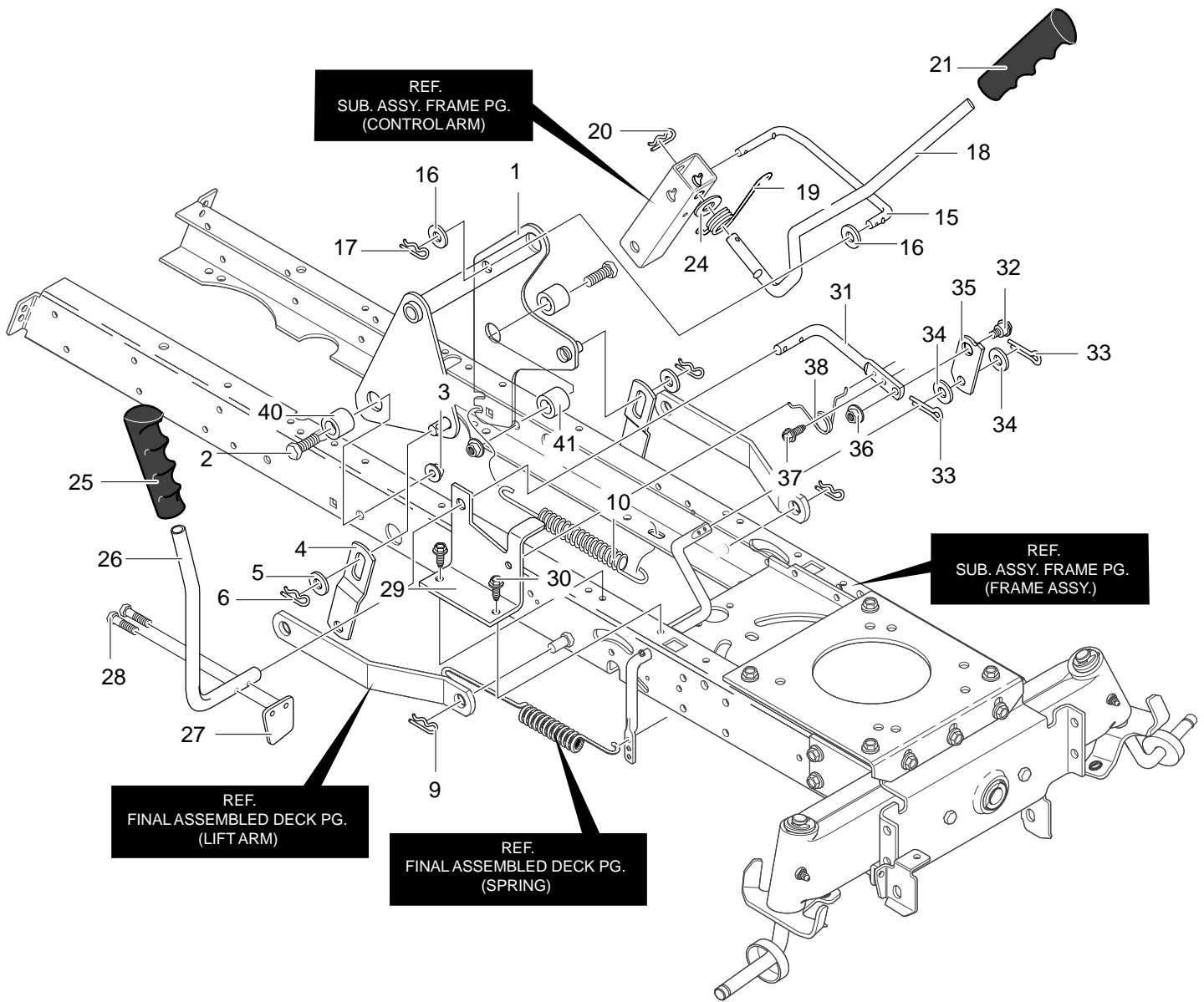

CODE144S

REPAIR PARTS MOWER SUSPENSION ASSEMBLY

Key No.	Description	Part No.	Key No.	Description	Part No.
1	Assembly, Lift Arm	MU95233-853	25	Grip	MU94496
2	Screw, 1/2-13x1.50	MU711917	26	PTO Handle	MU712035
3	Nut, 1/2-13 Lock	MU711918	27	Paddle, Switch	MU95284
4	Bracket, Lift Link	MU94262-853	28	Screw, Thread Form	MU711621
5	Washer, Flat	MU711617	29	Bracket, PTO	MU94018-853
6	Hair Pin	MU711676	30	Screw, 5/16-18x.50	MU780055
9	Hair Pin	MU711676	31	Lever, PTO	MU95283
10	Spring, Extension	MU710235	32	Bolt, Shoulder 3/8-16	MU711613
15	Link-Lift Handle	MU711981	33	Hair Pin	MU711659
16	Washer, Flat	MU711617	34	Washer, Flat	MU711615
17	Hair Pin	MU711676	35	Link PTO	MU95282
18	Handle, Lift	MU690532	36	Nut, 3/8-16	MU711622
19	Torsion Spring	MU710111	37	Screw 5/16-18x.75	MU711606
20	Hair Pin	MU711676	38	Torsion Spring	MU710141
21	Grip, Lift	MU94497	40	Spacer	MU94309
24	Washer, Flat	MU711616	41	Spacer, Sleeve	MU56150

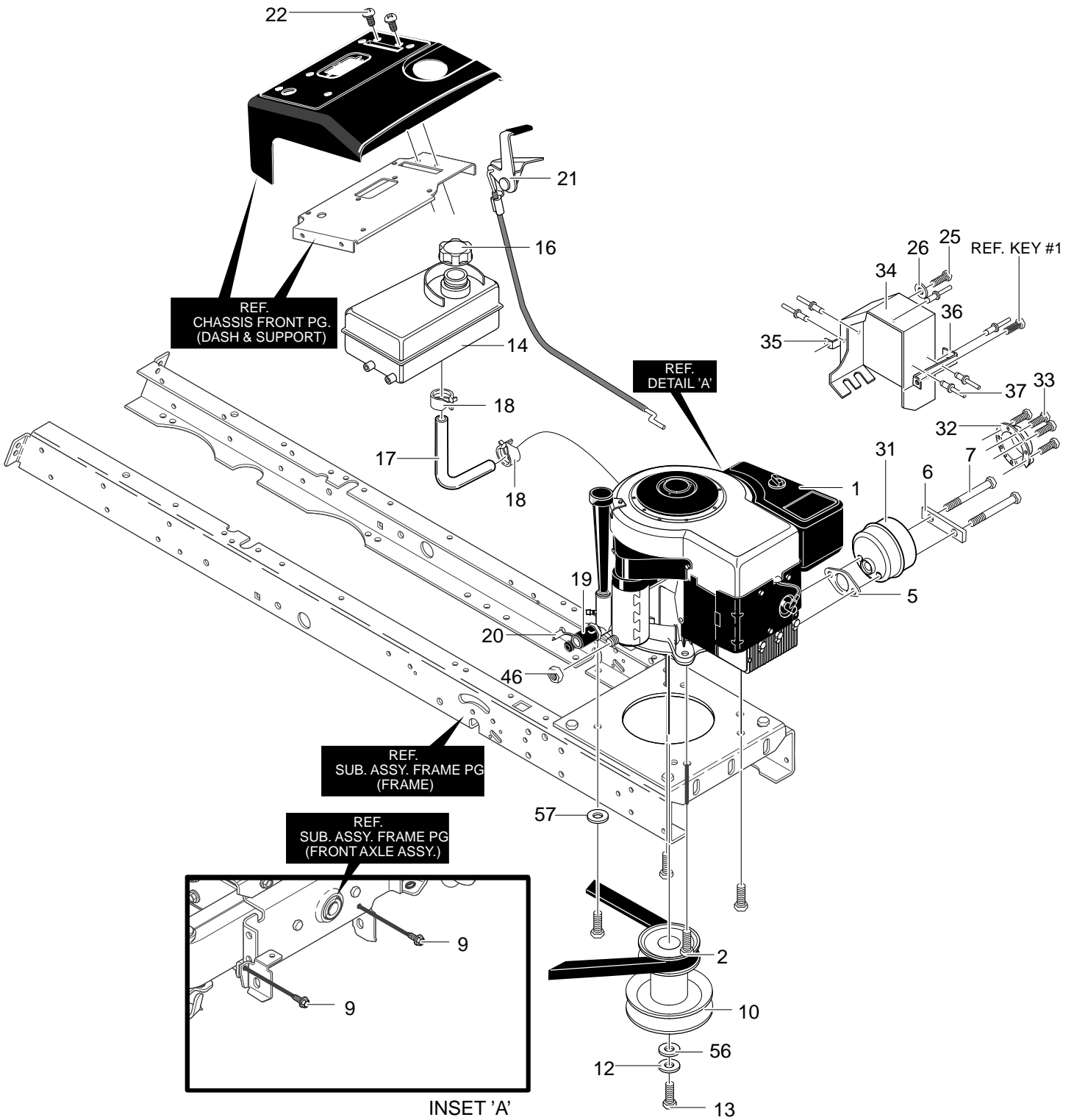

CODE144S

REPAIR PARTS ENGINE AND CONTROL ASSEMBLY

Key No.	Description	Part No.	Key No.	Description	Part No.
1	13HP (See Engine Manual)	Engine	20	Cap, Oil Drain Valve	MU327422
—	Clip, Speed	MU94951	21	Throttle Control	MU94361
2	Engine Bolt 3/8x1.25	MU0025X7	22	Screw, #8–16x.38	MU711637
5	Muffler Gasket	MU91309	25	Screw, 1/420x.50	MU711592
6	Lock Bracket	MU92378	26	Washer (18x32)	MU710249
7	Screw, 5/16–18x4.125	MU712065	31	Muffler	MU91271
9	Screw, 5/16–18x.75	MU711606	32	Deflector, Exhaust	MU23740
10	Stack Pulley	MU690456	33	Screw, #8–32x.38	MU712070
12	Washer, Regsptlk	MU120383	34	Heat Shield	MU95031
13	Bolt, 7/16–20x1.75LG	MU1x169	35	L–Bracket	MU94359
14	Fuel Tank 1.4 Gal.	MU92342	36	L–Bracket	MU94360
16	Fuel Cap	MU92317	37	Pop Rivet	MU712066
17	Tubing 14.50 Inches	MU50118	46	Nut, 1/4–20 Reghexjam	MU711601
18	Clamp, Fuel	MU336890	56	Washer, Flat	MU17x170
19	Oil Drain Valve Assembly	MU325547	57	Washer, Exlk	MU711668

CODE144S

REPAIR PARTS DECK ASSEMBLY

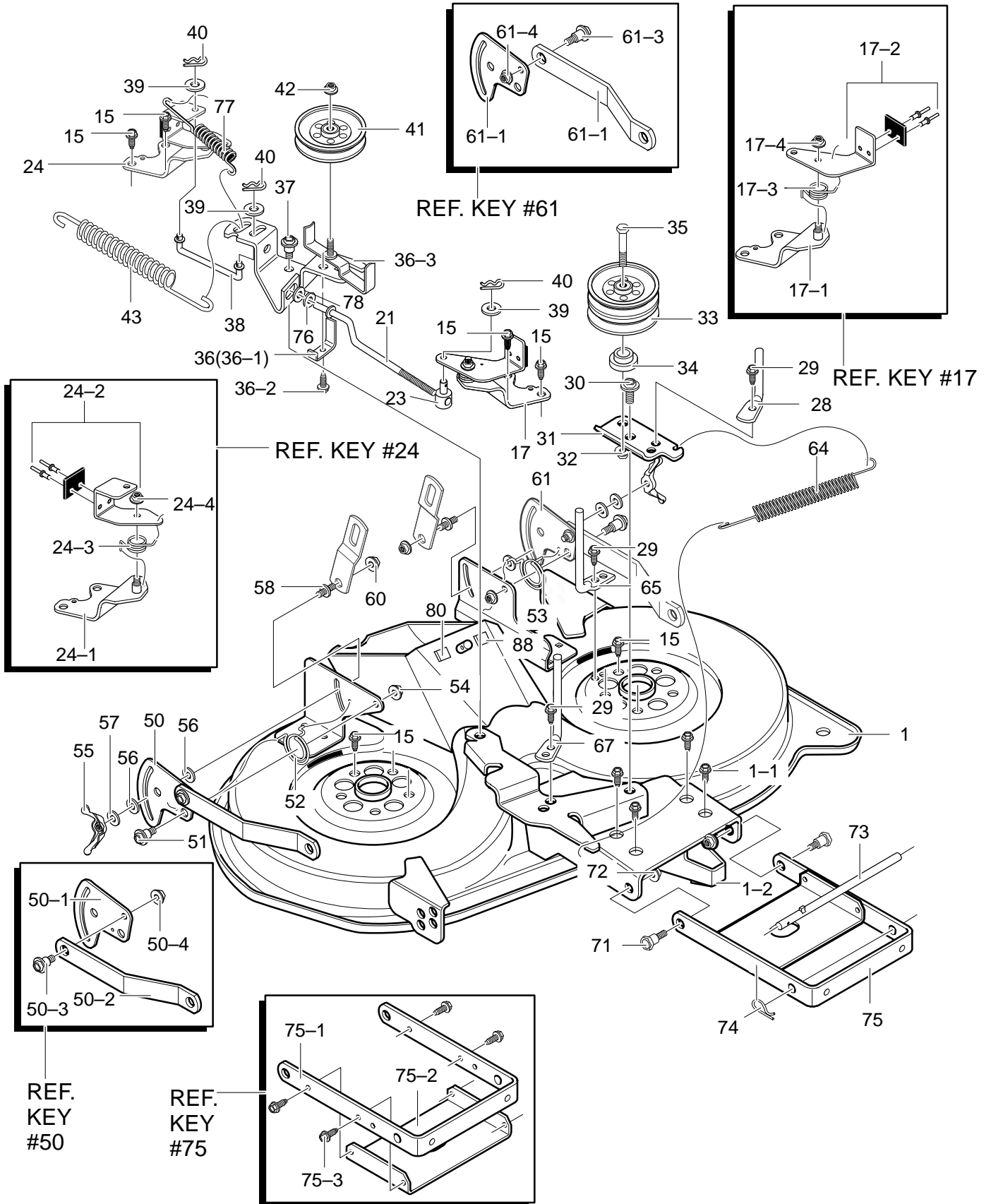

344276C

CODE144S

REPAIR PARTS DECK ASSEMBLY

Key No.	Description	Part No.	Key No.	Description	Part No.
1	Housing, 40" Deck	MU690109-853	50-1	Plate-Suspension	MU94128
17	Brake Arm Assembly LH	MU94665-853	50-2	Suspension Bracket Rear	MU94055
17-1	Brake Support Assembly LH	MU94293	50-3	Bolt, Shoulder	MU710095
17-2	Brake Arm	MU94291	50-4	Nut, 3/8-16	MU710140
17-3	Spring, Torsion	MU710110	51	Bolt, Shoulder	MU711611
17-4	Nut, 5/16-18	MU710205	52	Spring, Torsion RH	MU710112
21	Link, Brake LH	MU690021	53	Spring, Torsion LH	MU710113
23	Nut, Adjusting	MU711591	54	Nut, 3/8-16	MU711622
24	Brake Arm Assembly RH	MU94664-853	55	Wingnut, 5/16-18	MU711600
24-1	Brake Support RH	MU94294	56	Pad, Friction	MU94137
24-2	Brake Arm RH	MU94292	57	Washer	MU711628
24-3	Spring, Torsion	MU710077	58	Pin, Hanger	MU711595
24-4	Nut, 5/16-18	MU710205	60	Nut, 3/8-16	MU711622
28	Belt Guide	MU711912	61	Assy., Plate Rear Sus Brkt., LH	MU690159-853
29	Screw, 5/16-18x.50	MU780055	61-1	Plate-Suspension	MU94128
30	Bolt, Shoulder	MU711613	61-2	Suspension Bracket, Rear	MU94055
31	Arm, Double Idler	MU94261-853	61-3	Bolt, Shoulder	MU710095
32	Nut, 3/8-16	MU711622	61-4	Nut, 3/8-16	MU710140
33	Pulley, Idler Double Vee	MU94279	64	Spring, Extension	MU710233
34	Spacer	MU94269	65	Belt Guide	MU711913
35	Screw, 3/8-16x3.00	MU711915	67	Belt Guide	MU690030
36	Idler Arm Assembly	MU94973-853	71	Shoulder Bolt	MU711611
36-1	Spring,-Belt Guide	MU94312	72	Nut, 3/8-16	MU711622
36-2	Screw, 1/4-20x.50	MU710264	73	Rod, Hanger	MU95295
36-3	Idler Arm	MU94298	74	Hair Pin	MU711676
37	Bolt, Shoulder	MU711613	75	Assembly, Bracket & Stiffener	MU690058-853
38	Link, Brake RH	MU690023	75-1	Bracket, Front Suspension	MU94058
39	Washer, Flat	MU712480	75-2	Stiffener	MU95057
40	Hair Pin	MU711682	75-3	Screw, 5/16-18x.75	MU710079
41	Pulley, Idler	MU690024	76	Flatwasher	MU583409
42	Nut, 3/8-16	MU711622	77	Spring, Extension	MU710658
43	Spring, Extension	MU710234	78	Washer, Flat	MU712480
50	Assy, Plate,Rear Sus Bkt RH	MU690158-853	80	Pad, Adhesive	MU318197

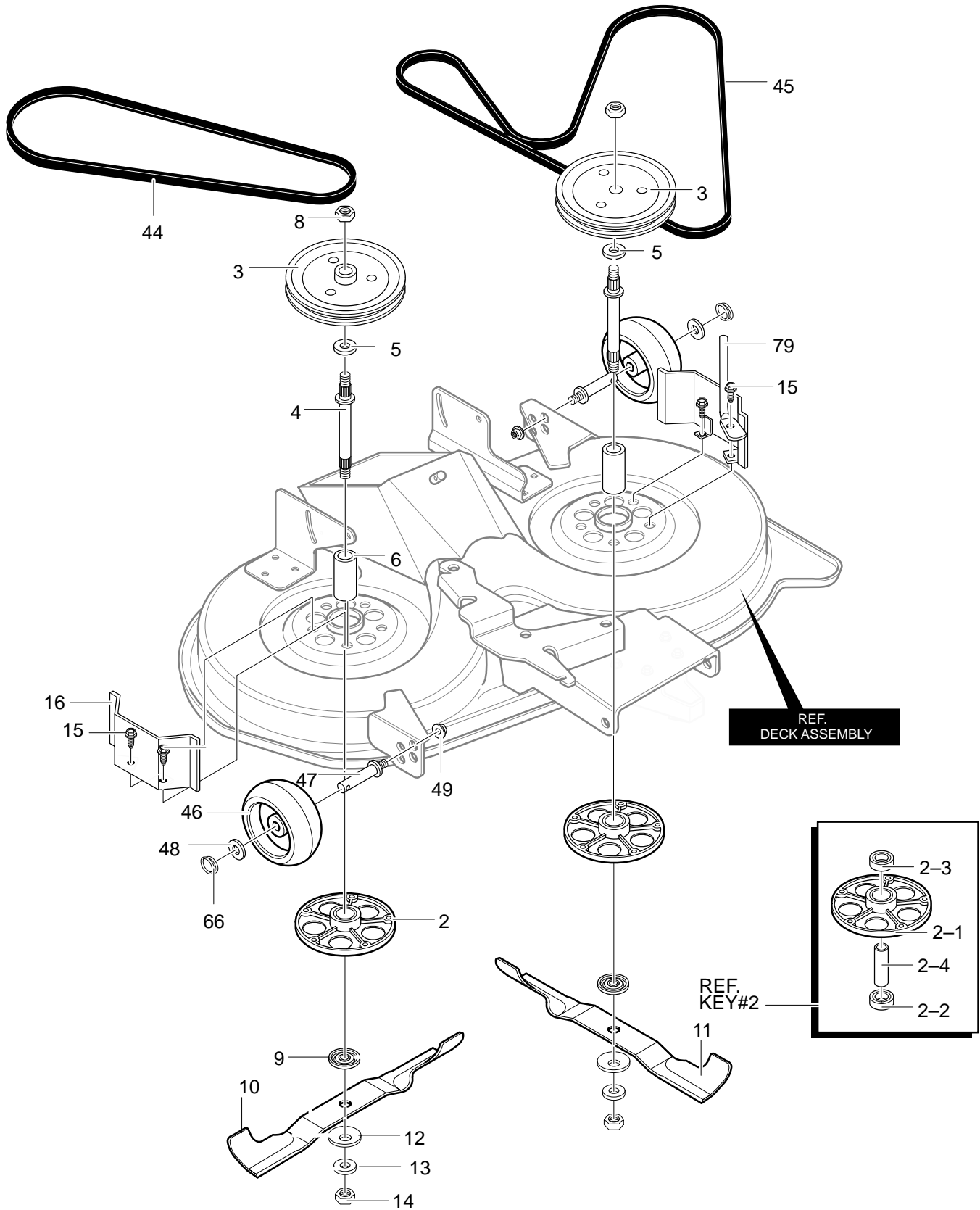

CODE144S

REPAIR PARTS DECK ASSEMBLY

Key No.	Description	Part No.	Key No.	Description	Part No.
2	Assembly, Jackshaft Housing	MU94305	12	Washer, Bellville	MU17x166
2-1	Housing, Jackshaft	MU94282	13	Flatwasher	MU17x165
2-2	Bearing, Lower Jackshaft	MU92282	14	Nut, 9/16-18	MU711910
2-3	Bearing, Upper Jackshaft	MU92281	15	Screw, 3/8-16x1.00	MU711911
2-4	Spacer	MU90904	16	Pulley Cover	MU94288-853
3	Pulley, Deck	MU690020	44	Belt, V 46.5LG	MU710231
4	Jackshaft	MU91922	45	Belt, Deck	MU690071
5	Flatwasher	MU17x165	46	Gauge Wheel	MU92683
6	Spacer	MU91903	47	Shoulder Bolt	MU711746
8	Nut, 9/16-18	MU711910	48	Flatwasher	MU711615
9	Adapter, Deck	MU94207	49	Nut, 3/8-16	MU711622
10	Blade, LH	MU690499	66	Circle Pin	MU711764
11	Blade, RH	MU690500	79	Rod, Belt Guide	MU95280

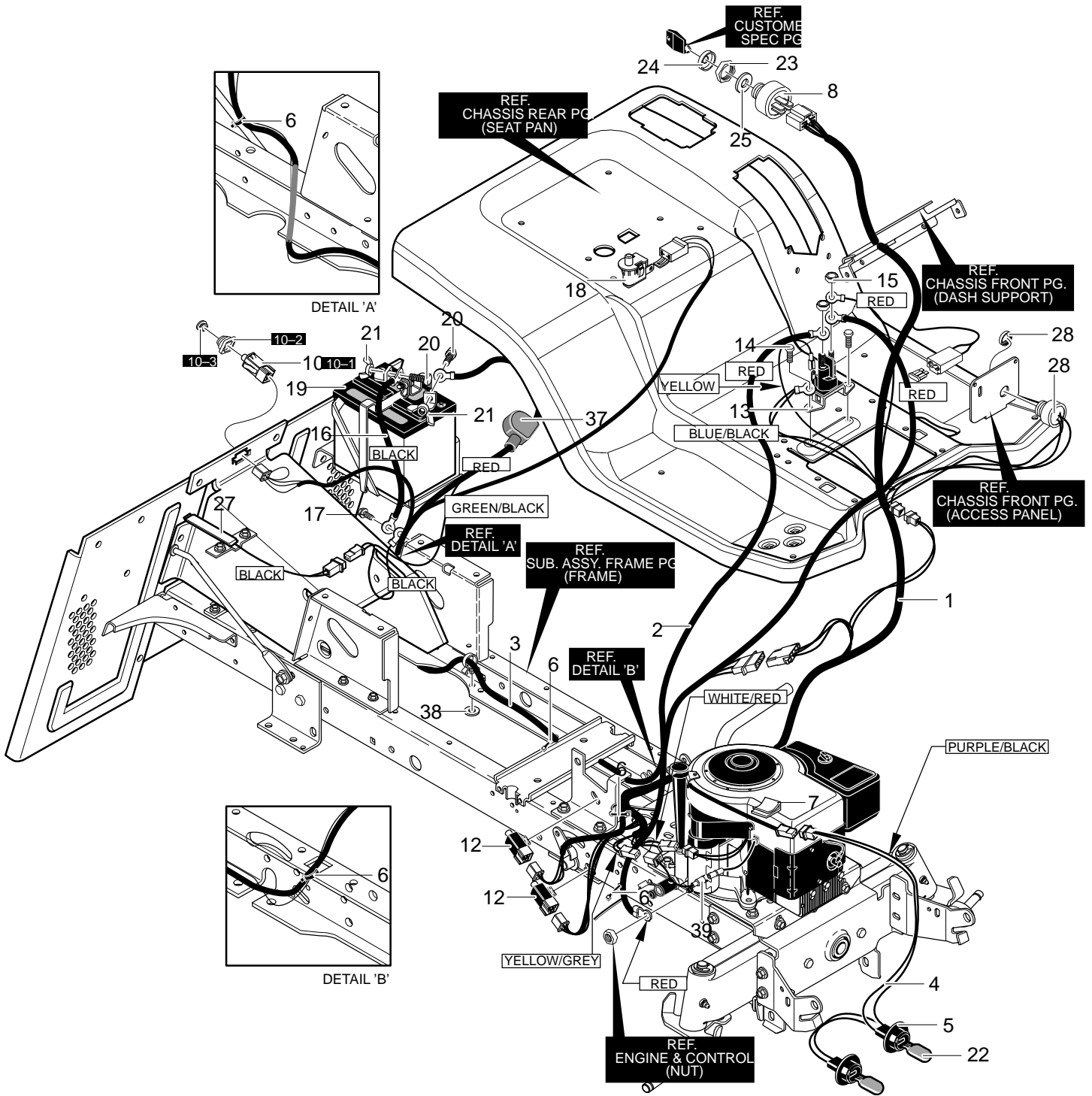

CODE144S

REPAIR PARTS ELECTRICAL ASSEMBLY

Key No.	Description	Part No.	Key No.	Description	Part No.
1	Wire Harness	MU95380	16	Ground Wire	MU95420
2	Wire, Lead Solenoid to Start	MU711579	17	Screw, 1/4x.50	MU711619
3	Rear Harness	MU95381	18	Seat Switch	MU94159
4	Wire Harness, Headlight	MU340513	19	Battery 5 Plate	MU92739
5	Socket, Lamp	MU92372	20	Bolt, 1/4-20x.63	MU711680
6	Cable Tie	MU57444	21	Wing Nut	MU711636
7	Wire Clip, Adhesive	MU55939	22	Light Bulb	MU90084
8	Switch, Ignition	MU94878	23	Nut, 5/8-8 Acme Delta	MU327352
10	Assy, Switch Double Pole Delta	MU690106	24	Boot, Ign. Switch	MU300194
10-1	Switch, Double	MU320082	25	Washer, Regintlk	MU313683
10-2	Boot, Switch	MU690074	27	Tape Switch	MU95330
10-3	Switch Cap	MU690075	28	Buzzer, For Bag Full	MU95391
12	Switch, Limit	MU94136	37	Boot, Battery	MU335417
13	Solenoid	MU94613	38	Flatwasher	MU711666
14	Screw 1/4x.50	MU711619	39	Harness Adapter	MU94348
15	Nut, 1/4-20	MU711632		15 Amp Fuse	MU302031

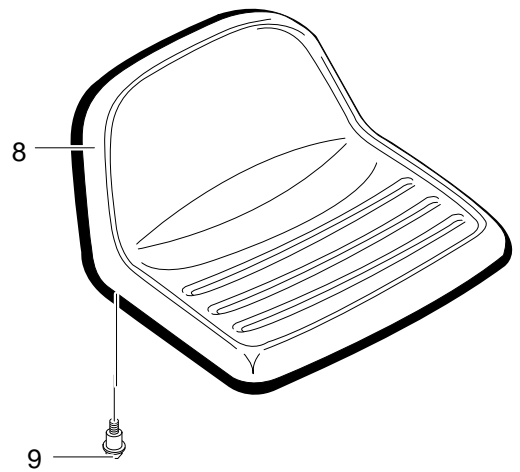
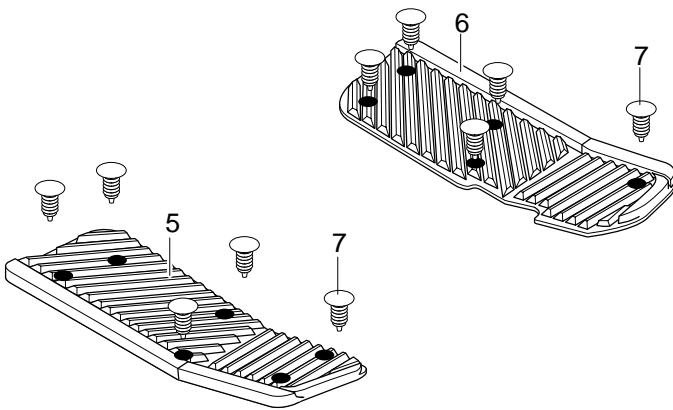
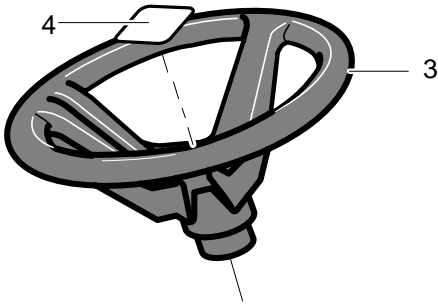
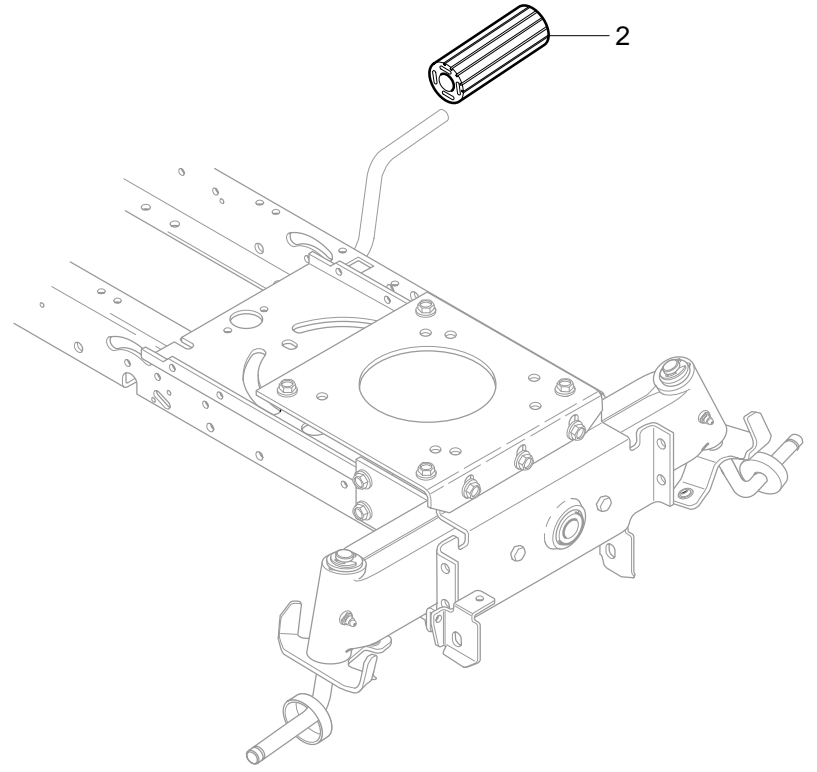
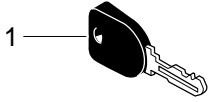

Key No.	Description	Part No.
1	Ignition Key	MU327350
2	Cover, Pedal Brake/Clutch	MU21544
3	Steering Wheel	MU95185
4	Insert, 4-Spoke	MU711326
5	Foot Pad RH	MU95409
6	Foot Pad LH	MU95408
7	Ratchet Fastener	MU309325
8	Seat	MU95415
9	Shoulder Bolt 5/16-18	MU711654

(D) Übereinstimmungs–Bescheinigung

(GB) Certificate of conformity

(F) Certificat de conformité

(I) Certificato di conformità

(E) Certificado de conformidad

(NL) Conformiteitsverklaring

(P) Declaração de conformidade

(S) Konformitetsintyg

(N) Konformitetserklæring

(DK) Overensstemmelseserklæring

(SF) Vaatimustenmukaisuusilmoitus

Der Unterzeichnete / I the undersigned / Le soussigné / Il firmatario / El abajo firmante / Ondergetekende / O abaixo assinado / Undertecknad / Undertegnede / Undertegnet / Allekirjoittanut

MURRAY, INC.

bestätigt, daß der Rasenmäher / certify that the lawn mower / certifie que la tondeuse à gazon / certifica che il tosaerba / certifica que la cortadora de césped / bevestigt dat de grasmaaimachine / certifica que o cortador de grama / bekräftar härmed att gräsklipparen / attesterer at gressklipperen / bekræftiger hermed at denne græsslåmaskine / todistaa, että ruoholeikkuri

1. Bauart Category Categorie Categoria Categoría Categorie Categoria Kategori Kategori Kategori Kategoria	RASENTRAKTOR LAWNMOWER TONDEUSE A GAZON TORSÆRBA CORTADORA DE CESPED GRASMAAIMACHINE CORTADOR DE GRAMA GRÄSKLIPPARE GRESSKLIPPER GRÆSSLÅMASKINE RUOHONLEIKKURI
---	--

2. Fabrikmarke / Make / Marque / Marca / Marca / Merk / Marca / /Fabriksmärke / Merke / Mærke / Merkki	MURRAY
---	--------

3. Typ / Type / Type / Tipo / Tipo / Model / Tipo / Typ / Type / Type / Tyypä	13 HP / 40
---	------------

4. Serienidentifizierung / Line Specification / Numéro de Série / Numero di serie / Número de serie / Seriennummer / Número de série / Seriennummer / Seriennummer / Seriennummer / Sarjanumero	40316x11B (CODE144S)
---	----------------------

5. Motor / Engine / Moteur / Motore / Motor / Motor / Motor / Motor / Motor / Motor / Moottori – Hersteller / Manufacturer / Fabricant / Produttore / Fabricante / Fabrikant / Fabricante // Fabrikant / Fabrikant / Fabrikant / Valmistaja – Typ / Type / Type / Tipo / Tipo / Model / Tipo / Typ / Type / Type / Tyypä – Prüfdrehzahl u/min – Control of the speed's rotation rpm – Contrôle du régime de rotation t/mn – Controllo del regime di giri al minuto – Control de la velocidad de rotación rpm – Controle van de rotatie snelheid t/min. – Controle de velocidade de rotação rpm – Rotationshastighet varv per minut – Roteringshastighet rpm – Rotationshastighed rpm – Kiertonopeuden kontrolli kierrosta/min.	<u>BRIGGS & STRATTON</u> 28T707–1121–E1 2400
--	--

mit den Vorschriften der Richtlinie 84/538 EWG übereinstimmt / conforms to the specifications of Directive 84/538 EEG / est conforme aux spécifications de la directive CEE 84/538 / è conforme alle specifiche della direttiva CEE 84/538 / se conforma a las especificaciones de la directiva CEE 84/538 / in overeenstemming is met de specificaties van de Richtlijn 84/538 EEG / obedece as especificações da diretiva 84/538 C.E.E. / överensstämmer med specifikationerna i EWGs direktiv 84/538 / samsvarer med spesifikasjonene ifølge EF forskrift 84/538 / møder specifications direktivet 84/538 EØF / on direktiivin 84/538 EY spesifikaatioiden mukainen.

Garantierter Schalleistungspegel Guaranteed sound power level Niveau de puissance acoustique garanti Livello di potenza acustica garantito Nivel garantizado de potencia acústica Gewaarborgd niveau van geluidssterkte Nível de ruído motriz garantido Garanterad ljudstyrksnivå Garantert lydnivå Lydniveau garanti Taattu äänenvoiman taso	100 dB (A)
Art der Schneidevorrichtung Type of cutting device Genre du dispositif de coupe Tipo di dispositivo di taglio Tipo de dispositivo de corte Soort snijmiddel Tipo de dispositivo cortante Typ av skäranordning Type klipperedskap Bladtype Leikkurityyppi	SICHELMESSER ROTATING BLADE LAME ROTATIVE LAMA ROTANTE CUCHILLA GIRATORIA ROTEREND BLAD LÂMINA ROTATIVA ROTERANDE BLAD ROTERENDE BLAD ROTERENDE BLADE PYÖRIVÄ TERÄ
Schnittbreite / Width of cut / Largeur de coupe / Ampiezza di taglio / Ancho de corte / Snijbreedte / Extensão do corte / Skärbredd / Snittbredde / Skærebrede / Leikkuujäljen leveys	102 cm
Umdrehungszahl der Schneidevorrichtung Speed of rotation of the cutting device Vitesse de rotation du dispositif de coupe Velocità di rotazione del dispositivo di taglio Velocidad de rotación del dispositivo de corte Rotatiesnelheid van het snijmiddel Velocidade de rotação do dispositivo cortado Skäranordningens rotationshastighet Rotasjonsfart klipperedskap Rotationshastighed Leikkurin pyörimisnopeus	2226 u/min. rpm t/mn g/min rpm t/min. rpm varv per minut rpm rpm kierrosta/min.
Geschehen zu / Done at / Fait á / Prodotto a / Hecho en / Opgemaakt te / Fabricado em / Intygad / Fullført / fremstillet i / Tehty	Brentwood, Tennessee U.S.A. 37027
am / on / le / ll / el / op / em / den / den / dato / a.p.	22.11.99



(Unterschrift / Signature / Signature / Firma / Handtekening / Firma / Underskrift / Underskrift / Underskrift / Allekirjoitus)

DIRECTOR - INTERNATIONAL SALES

(Amtsbezeichnung / Position / Fonction / Funzione / Puesto / Functie / Título / Yrke / Stilling / Stilling / Asema)

-
- (D) EG–Konformitätserklärung**
entsprechend der Richtlinie 98/37/EG
entsprechend der EG–Richtlinien 89/336
- (GB) EC Certificate of Conformity**
conforming to Directive 98/37/EC
conforming to EEC Directives 89/336
- (F) Déclaration de conformité pour la CEE**
conforme à la directive 98/37/CE
conforme aux directives CEE 89/336
- (I) Certificato di conformita' comunitario**
conforme alla Direttiva 98/37/CE
conforme alle Direttive CEE 89/336
- (E) Declaración de Conformidad**
según la directiva 98/37/CE
según las directivas de la CEE 89/336
- (NL) EG–Conformiteitsverklaring**
overeenkomstig de Richtlijn 98/37/EG
overeenkomstig de EG–Richtlijn 89/336
- (P) Declaração de conformidade**
conforme com a Diretiva 98/37/EC
conforme com as Diretivas da C.E.E. 89/336
- (S) EU–konformitetsintyg**
överensstämmande med föreskrift 98/37/EC
överensstämmande med EU–föreskrifter 89/336
- (N) EU–konformitetserklæring**
overholder direktiv 98/37/EC
overholder EU–direktiver 89/336
- (DK) EU–overensstemmelseserklæring**
overholder direktiv 98/37/EC
overholder EU–direktiver 89/336
- (SF) EY: n Vaatimustenmukaisuusilmoitus**
noudattaa direktiiviä 98/37/EY
noudattaa EY–direktiivin 89/336

Wir
(Name des Anbieters)

Nosotros
(nombre del fabricante)

Vi
(Tilbyerens navn)

We
(Name of supplier)

Wij
(naam van de leverancier)

Vi
(Udbyderens navn)

Nous
(Nom du vendeur)

Nós
(nome do fornecedor)

Me
(Tuotteen toimittaja)

Noi
(Nome del fornitore)

Vi
(anbudsgivarens namn)

MURRAY, INC.

(vollständige Anschrift der Firma – bei in der Gemeinschaft niedergelassenen Bevollmächtigten ebenfalls Angabe der Firma und Anschrift des Herstellers)
(full address of company – where this concerns authorized agents within the Common Market, also state the company name and manufacturer)
(Adresse complète de la firme – en cas de mandataires établis dans la CEE, prière d'indiquer également la raison sociale et l'adresse du fabricant)
(indirizzo completo della Società operante nell'ambito del mercato comune, indicazione della Società e indirizzo del Costruttore)
(dirección completa de la empresa, al tratarse del representante legal dentro de la comunidad, indíquese igualmente el nombre del fabricante)
(volledig adres van de firma – bij een in de gemeenschap toegelaten gemachtigde eveneens de firma en het adres van de fabricant aangeven)
(direcção completa de empresa – no caso de representantes estabelecidos na comunidade indicar também o nome da empresa e a direcção do fabricante)
(fullständig företagsadress – vid befullmäktigade samarbetspartner med säte inom EU uppges även tillverkarens företagsnamn och adress)
(Firmaets fullstændige adresse – såfremt representant findes etableret i EU skal fabrikantens firmanavn og adresse oplyses)
(fuldstændig firmaadresse – såfremt repræsentant findes etableret i EF skal fabrikantens firmanavn og adresse ligeledes oplyses)
(Yhtiön täydellinen osoite – jos tämä koskee valtuutettua agenttia yhteisön alueella, ilmoita myös yhtiön nimi ja valmistaja)

erklären in alleiniger Verantwortung, daß das Produkt
declare in sole responsibility, that the product
déclarons sous notre seule responsabilité que le produit
dichiariamo sotto la nostra piena responsabilità che il prodotto
declaramos bajo responsabilidad propia que el producto
verklaren enig in verantwoording, dat het produkt
declaramos com responsabilidade própria que o produto
intyggar med ensamansvar att nedanstående produkt
erklærer som eneansvarlig at produktet
erklærer som eneansvarlig, at produktet
ilmoitamme yksin vastaavamme, että tuote

40316x11B (CODE144S)

(Fabrikat, Typ) (Make, model) (Marque, modèle) (Marca, tipo)
(Marca, modelo) (Fabricant, type) (Marca, modelo) (Fabrikat, typ)
(Fabrikat, type) (Mærke, type) (Merkki, malli)

auf das sich diese Erklärung bezieht, den einschlägigen grundlegenden Sicherheits- und Gesundheitsanforderungen der Richtlinie 98/37/EC, (falls zutreffend) sowie den Anforderungen der anderen einschlägigen EG-Richtlinien entspricht

to which this certificate applies, conforms to the basic health and safety requirements of Directive 98/37/EC, (if applicable) and to the other relevant EEC Directives

faisant l'objet de la déclaration est conforme aux prescriptions fondamentales en matière de sécurité et de santé stipulées dans la Directive 98/37/CE, (le cas échéant) ainsi qu'aux prescriptions des autres Directives de la CEE établies dans ce domaine
cui la presente dichiarazione si riferisce, è conforme ai requisiti di Direttiva 98/37/CE in materia di sicurezza e sanità, (nel caso specifico) nonché a quelli di altre direttive CE pertinenti

al cual se refiere la presente declaración corresponde a las exigencias básicas de la directiva 98/37/CE, referentes a la seguridad y a la sanidad, (en caso dado), así como a las exigencias de las demás normativas de la CEE

waarop deze verklaring betrekking heeft, overeenkomt met de basiseisen van de richtlijn 98/37/EG m.b.t. veiligheid en gezondheid, (indien van toepassing) alsook met de eisen van de andere EG-richtlijnen terzake geldig

a que se refere esta declaração corresponde às exigências fundamentais respectivas à segurança e à saúde da Diretiva 98/37/CE (quando aplicável), assim como às exigências das outras diretivas relevantes da C.E.E.

för vilket detta intyg gäller, uppfyller de grundläggande säkerhets- och hälsoskyddskraven enligt föreskrift 98/37/EC, (om tillämplig) samt uppfyller kraven enligt andra relevanta EU-föreskrifter

som denne erklæring vedrører, oppfylder de grunnleggende sikkerhets- og sunnhetskrav i direktivet 98/37/EC, (hvis relevant) samt kravene i andre relevante EU-direktiver

som denne erklæring vedrører, overholder de grundlæggende sikkerheds- og sunhedskrav i direktiv 98/37/CE samt (hvis relevant), samt kravene i andre relevante EU-direktiver

johon tämä ilmoitus liittyy, vastaa direktiivissä 98/37/EY mainittuja perusturvallisuus- ja terveysvaatimuksia (soveltuvin osin) sekä muita siihen kuuluvia EY direktiivejä

89/336 EEC

(Titel und/oder Nummer sowie Ausgabedatum der anderen EG-Richtlinien)

(Title and/or number and date of issue of the other EEC Directives)

(Titre et/ou numéro et date de publication des autres directives de la CEE)

(Titolo e/o numero, data di promulgazione delle altre direttive CEE)

(Título y/o número así como fecha de publicación de las demás normativas de la CEE)

(Titel en/of nummer alsook datum van uitgave van de andere EG-richtlijnen)

(Título a/ou número assim como data de publicação das outras normas da C.E.E.)

(Titel och/eller nummer samt publikationsdatum för övriga EU-normer)

(Titel og/eller nummer og utgave datum på de andre vedkommende EF-retningslinjerne)

(Titel og/eller nummer samt udgivelsesdato på de andre EF-direktiver)

(Otsikko ja/tai numero ja päiväys muista EY direktiiveistä)

(falls zutreffend) (if applicable) (le cas échéant) (nel caso specifico) (en caso dado) (indien van toepassing) (em caso afirmativo)

(om tillämpligt) (dersom dette tiltreffer) (hvis relevant) (soveltuvin oin)

Zur sachgerechten Umsetzung der in den EG-Richtlinien genannten Sicherheits- und Gesundheitsanforderungen wurde(n) folgende Norm(en) und/oder technische Spezifikation(en) herangezogen: BS EN 386:1997, BS EN 1033:1996 und/oder BS EN 1032:1997

To effect correct application of the safety and health requirements stated in the EEC Directions, the following standards and/or technical specifications were consulted: BS EN 386:1997, BS EN 1033:1996 and/or BS EN 1032:1997

Pour mettre en pratique dans les règles de l'art les prescriptions en matière de sécurité et de santé stipulées dans les Directives de la CEE, il a été tenu compte de la/des norme(s) et/ou de la/des spécification(s) technique(s) suivante(s): BS EN 386:1997, BS EN 1033:1996 et/ou BS EN 1032:1997

Per un'opportuno riscontro nell'ambito della normativa CEE delle norme di sicurezza e sanitarie sopra citate, è (sono) stata(e) consultata(e) la(e) seguente(i) norma(e) e/o specifica(che) tecnica(che): BS EN 386:1997, BS EN 1033:1996 e/o BS EN 1032:1997

Con el fin de realizar de forma adecuada las exigencias referentes a la seguridad y a la sanidad mencionadas en las normativas de la CEE (fué(ron) consultada(s) la(s) siguiente(s) normativa(s) y especificación(es) técnica(s): BS EN 386:1997, BS EN 1033:1996 y/o BS EN 1032:1997

Om de veiligheids- en gezondheidseisen, die in de EG-richtlijnen vermeld zijn, in juiste vorm om te zetten, is/zijn van volgende norm(en) en/of technische specificatie(s) gebruik gemaakt: BS EN 386:1997, BS EN 1033:1996 en/of BS EN 1032:1997

Com o fim de realizar de forma apropriada as exigencias referentes à segurança e à saúde mencionadas nas normas da C.E.E. consultou-se a(s) seguinte(s) norma(s) e/ou especificação(ões) técnica(s): BS EN 386:1997, BS EN 1033:1996 e/ou BS EN 1032:1997

Följande norm(er) och/eller teknisk(a) specifikation(er) har legat till grund för ett fackmässigt införande av de i EU-normerna angivna säkerhets- och hälsoskyddsföreskrifterna: BS EN 386:1997, BS EN 1033:1996 och/eller BS EN 1032:1997

Følgende normer og/eller tekniske spesifikasjoner er lagt til grunn for gjennomførelse av EU-retningslinjenes nevnte sikkerhets- og sunnhetskrav: BS EN 386:1997, BS EN 1033:1996 og/eller BS EN 1032:1997

Til gennemførelse af de i EF-direktivet nævnte sikkerheds- og sundhedskrav er følgende standard(er) og/eller tekniske specifikation(er) anvendt: BS EN 386:1997, BS EN 1033:1996 og/eller BS EN 1032:1997

EY direktiiveissä mainittujen turvallisuus- ja terveysvaatimusten oikean käytön varmistamiseksi on seuraavia standardeja ja/tai teknisiä erittelyjä käytetty: BS EN 386:1997, BS EN 1033:1996 ja/tai BS EN 1032:1997

98/37/EC

89/336 EEC

(Titel und/oder Nummer sowie Ausgabedatum der Norm(en) und/oder der technischen Spezifikation(en))

(Title and/or number and date of issue of standards and/or specifications)

(Titre et/ou numéro et date de publication de la/des norme(s) et/ou de la/des spécification(s) technique(s))

(Titolo e/o numero, data di promulgazione della(e) norma(e) e/o specifica(che) tecnica(che))

(Título y/o número así como fecha de publicación de la(s) normativa(s) y/o de la(s) especificación(es) técnica(s))

(Titel en/of nummer alsook datum van uitgave van de norm(en) en/of van de technische specificatie(s))

(Título a/ou número assim como data de publicação da(s) norma(s) e/ou especificação(ões) técnica(s))

(Titel och/eller nummer samt publikationsdatum för norm(er) och/eller teknisk(a) specifikation(er))

(Titel og/eller nummer, samt utgivelsesdato på standarden(e) og/eller den (de) tekniske spesifikasjone (er))

(Titel og/eller nummer samt udgivelsesdato på standarden(erne) og/eller den(de) tekniske specifikation(er))

(Otsikko ja/tai numero ja päiväys käytetyistä standardeista ja/tai teknisistä erittelyistä)

Brentwood, TN USA 22.11.99

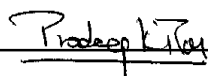

Director, International Sales

(Ort und Datum der Ausstellung)

(Name, Funktion und Unterschrift des Befugten)

(Place and date of issue)

(Name and job function of authorized person)

(Lieu et date)

(Nom, fonction et signature de la personne autorisée)

(Luogo e data del rilascio)

(Nome, qualifica e firma dell'incaricato)

(Lugar y fecha de expedición)

(Nombre, función y firma del encargado)

(Plaats en datum van de verklaring)

(Naam, functie en handtekening van bevoegd persoon)

(Lugar e data de emissão)

(Nome, cargo e assinatura do responsável)

(Utfärdat ort/datum)

(Namn, befattning och underskrift av behörig medarbetare)

(Sted og datum)

(Bemyndigtes navn, funksjon og underskrift)

(Sted og dato)

(Bemyndigedes navn, funktion og underskrift)

(Ilmoitus annettu paikka ja päiväys)

(Valtuutetun henkilön nimi ja tehtävä)