

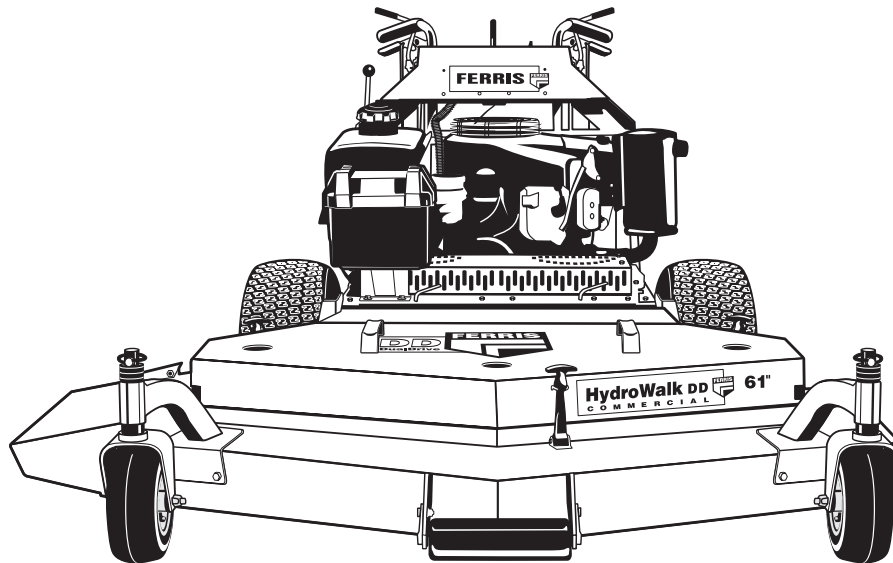

OPERATOR'S MANUAL



HydroWalk Series Dual Drive Walk-Behind Mowers

Powerheads

Model Number: Description:

DDSKAV15	Dual Drive w/ 15HP Kawasaki
DDSKAV15CE	Dual Drive w/ 15HP Kawasaki (Export)
DDSKAV17	Dual Drive w/ 17HP Kawasaki
DDSKAV17CE	Dual Drive w/ 17HP Kawasaki (Export)
DDSKAV23	Dual Drive w/ 23HP Kawasaki
DDSKAV23CE	Dual Drive w/ 23HP Kawasaki (Export)

48" Mower Decks

Model Number: Description:

DDS48	48" Mower Deck
DDS48R	48" Rear Discharge Mower Deck (Export)

52" Mower Decks

Model Number: Description:

DDS52	52" Mower Deck
DDS52R	52" Rear Discharge Mower Deck (Export)
DDSH52	52" E-Z Adjust Mower Deck

61" Mower Decks

Model Number: Description:

DDS61	61" Mower Deck
DDSH61	61" E-Z Adjust Mower Deck

FERRIS LIMITED WARRANTY

IMPORTANT

This warranty shall apply ONLY if the warranty registration form has been completed and returned to Ferris Industries, Inc. within 20 days from the date of delivery.

Ferris Industries, Inc. (Ferris) warrants, in accordance with the provisions below, to the original purchaser for the period of twenty-four (24) months from the date of delivery of a Ferris mower that the mower is free from defects in material or workmanship. Ferris' obligation under this warranty is to repair or replace, at Ferris' election, without charge and at the place of business of a dealer authorized to handle Ferris mowers, any part or parts of the machine which, in the judgment of Ferris, prove to be defective.

THIS WARRANTY AND FERRIS' OBLIGATION HEREUNDER IS IN LIEU OF ALL OTHER WARRANTIES, EXPRESSED OR IMPLIED, INCLUDING, WITHOUT LIMITATION, THE IMPLIED WARRANTY OF MERCHANTABILITY OR IMPLIED WARRANTY OF FITNESS FOR PARTICULAR PURPOSE, and all other obligations or liabilities of Ferris for incidental and consequential damages resulting from the design, manufacture, sale or use of the machine. No person is authorized to make any warranty or assume for Ferris any liability not strictly in accordance with this warranty.

This warranty shall not apply to any mower part which, in the judgment of Ferris, has been altered or tampered with in any way or has been subjected to misuse, neglect or accident, or has had the serial numbers altered, effaced or removed. This warranty does not apply to component parts not manufactured by Ferris (motors, batteries, tires, belts) except to the extent of their individual manufacturer's guarantees.

Ferris Industries, Inc. is continually striving to improve its products, and therefore reserves the right to make improvements or change when it becomes practical and possible to do so, without incurring any obligation to make changes or additions to the equipment sold previously.



Ferris Industries
5375 North Main Street
Munnsville, NY 13409
800-933-6175

www.ferrisindustries.com

© Copyright 2002 Ferris Industries
All Rights Reserved. Printed in USA.



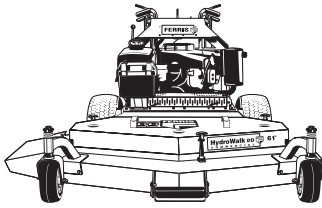

Table of Contents

Identification Tags	2	Troubleshooting, Adjustments & Service	
Safety Rules & Information		Troubleshooting the Mower	19
Training.....	3	Troubleshooting the Mower Deck.....	20
Preparation.....	3	Mowing Height Adjustment	21
Operation	4	Deck Leveling Adjustment (DDSH models)	22
Slope Operation	4	Mowing Height Adjustment (DDSH models).....	23
Children.....	5	Mower Belt Replacement.....	24
Emissions.....	5	Mower Belt Replacement (DDSH models)	25
Maintenance and Storage.....	5	Transmission Drive Belt Replacement.....	26
Decals	6	Transmission Neutral & Tracking Adjustments	27
CE Compliance Specs.....	7	Neutral Adjustment	27
Features & Controls		Tracking Adjustment.....	27
Control Functions.....	8	Transmission Maintenance & Service.....	28
Safety Interlock System	9	Changing Oil & Filters	28
Operating the Dual Drive Walk-Behind		PTO Clutch Adjustment	29
General Operating Safety	10	Battery Service	30
Checks Before Starting	10	Checking the Battery Voltage	30
Starting the Engine	11	Charging A Completely Discharged Battery.....	30
Stopping the Mower	11	Jump Starting with	
Driving the Mower	11	Auxiliary (Booster) Battery	30
Mowing.....	12	Replacement Parts & Accessories	32
Pushing the Mower by Hand.....	12	Lawn Care & Mowing Information	LC-1
Storage.....	13	International Symbols.....	LC-8
Starting After Long Term Storage	13	Technical Manuals.....	LC-8
Regular Maintenance			
Maintenance Schedule	14		
Checking Tire Pressures.....	14		
Checking/Adding Fuel.....	15		
Fuel Filter	15		
Oil & Filter Change	15		
Check / Change Air Filter	15		
Check Hydraulic Oil Level	15		
Lubrication	16		
Battery Maintenance.....	17		
Checking Battery Fluid	17		
Cleaning the Battery and Cables.....	17		
Servicing the Mower Blades	18		

NOTE: In this manual, "left" and "right" are referred to as seen from the operating position.

⚠ WARNING

You must read, understand and comply with all safety and operating instructions in this manual before attempting to set-up and operate your machine.

Failure to comply with all safety and operating instructions can result in loss of machine control, serious personal injury to you and / or bystanders, and risk of equipment and property damage. The triangle in the text signifies important cautions or warnings which must be followed.

⚠ WARNING

Engine exhaust from this product contains chemicals known, in certain quantities, to cause cancer, birth defects, or other reproductive harm.

© Copyright 2002 Ferris Industries
All Rights Reserved. Printed in USA.

TP 100-7056-00-WD-F

Identification Tags

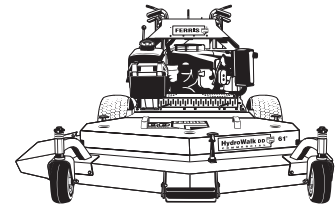

IDENTIFICATION TAG LOCATIONS

When contacting your Authorized Dealer for replacement parts, service, or information **YOU MUST HAVE THESE NUMBERS.**

North American Models

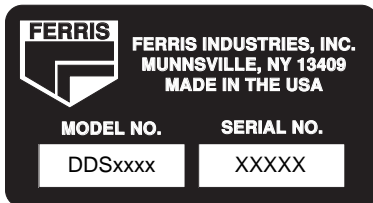

Powerhead Identification Tag

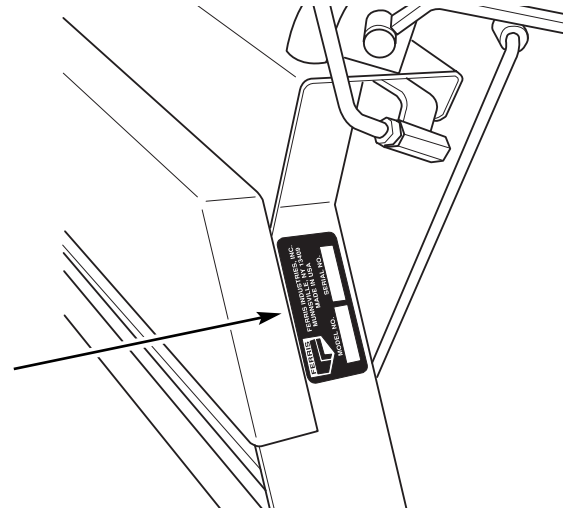

CE Models

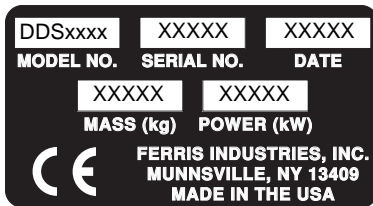

Mower Deck Identification Tag

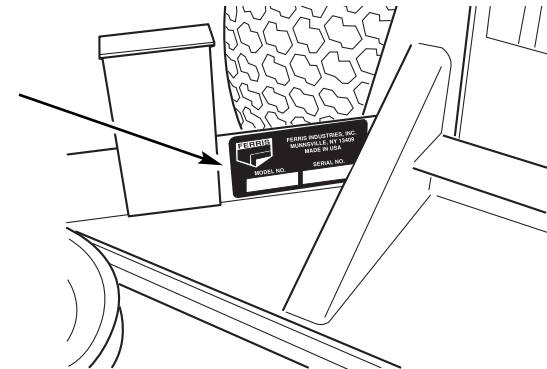

IDENTIFICATION NUMBERS

Record your model name, unit and mower deck serial numbers and engine serial number in the space provided for easy reference.

- The Powerhead I.D. tag is located on left-hand side of the handle bars.
- The Mower Deck I.D. tag is located on the right-hand side of the mower deck, under the belt shield.
- For location of Engine Serial Number, refer to the Engine Owner's Manual.

Be sure to fill out and return the Warranty Registration Card supplied with your unit.

PRODUCT REFERENCE DATA	
Model Description Name	
Powerhead MODEL Number	Powerhead SERIAL Number
Mower Deck MODEL Number	Mower Deck SERIAL Number
Dealer Name	Date Purchased
ENGINE REFERENCE DATA	
Engine Make/Model	Engine ID/Serial Number



Safety Rules & Information



Read these safety rules and follow them closely. Failure to obey these rules could result in loss of control of unit, severe personal injury or death to you, or bystanders, or damage to property or equipment. **This mowing deck is capable of amputating hands and feet and throwing objects.** The triangle in text signifies important cautions or warnings which must be followed.

TRAINING

- Read, understand, and follow all instructions in the manual and on the unit before starting. If the operator(s) or mechanic(s) can not read English it is the owner's responsibility to explain this material to them.
- Become familiar with the safe operation of the equipment, operator controls, and safety signs.
- All operators and mechanics should be trained. The owner is responsible for training the users.
- Only allow responsible adults, who are familiar with the instructions, to operate the unit.
- Never let children or untrained people operate or service the equipment. Local regulations may restrict the age of the operator.
- The owner/user can prevent and is responsible for accidents or injuries occurring to themselves, other people or property.
- Data indicates that operators, age 60 years and above, are involved in a large percentage of riding mower-related injuries. These operators should evaluate their ability to operate the riding mower safely enough to protect themselves and others from serious injury.

PREPARATION

- Evaluate the terrain to determine what accessories and attachments are needed to properly and safely perform the job. Use only accessories and attachments approved by the manufacturer.
- Wear appropriate clothing including safety shoes, safety glasses and ear protection. Long hair, loose clothing or jewelry may get tangled in moving parts.
- Inspect the area where the equipment is to be used and remove all objects such as rocks, toys and wire, which can be thrown by the machine.
- Use extra care when handling gasoline and other fuels. They are flammable and vapors are explosive.
 - a) Use only an approved container.
 - b) Never remove fuel cap or add fuel with the engine running. Allow engine to cool before refueling. Do not smoke.
 - c) Never refuel or drain the machine indoors.
- Check that operator's presence controls, safety switches and shields are attached and functioning properly. Do not operate unless they are functioning properly.

Safety Rules & Information

OPERATION

- Never run an engine in an enclosed area.
- Mow only in the daylight or with good artificial light, keeping away from holes and hidden hazards.
- Be sure all drives are in neutral and parking brake is engaged before starting engine. Only start engine from the operator's position. Use seat belts if provided.
- Be sure of your footing while using pedestrian controlled equipment, especially when backing up. Walk, don't run.
- Do not mow in reverse unless absolutely necessary. Always look down and behind before and while traveling in reverse.
- Be aware of the mower discharge direction and do not point it at anyone. Do not operate the mower without either the entire grass catcher or the deflector in place.
- Slow down and use caution when making turns and when changing directions on slopes.
- Never raise deck with the blades running.
- Never leave a running unit unattended. Always disengage the PTO, set parking brake, stop engine, and remove keys before dismounting. Keep hands and feet away from the cutting units.
- Turn off the PTO switch to disengage the blades when not mowing.
- Never operate with guards not securely in place. Be sure all interlocks are attached, adjusted properly and functioning properly.
- Never operate with the discharge deflector raised, removed or altered, unless using a grass catcher.
- Do not change the engine governor setting or over-speed the engine.
- Stop on level ground, lower implements, disengage drives, engage parking brake, shut off engine before leaving the operator's position for any reason including emptying the grass catchers or unclogging the chute.
- Stop equipment and inspect blades after striking objects or abnormal vibration occurs. Make necessary repairs before resuming operations.
- Keep hands and feet away from the cutting units.
- Never carry passengers and keep pets and bystanders away.
- Do not operate the unit while under the influence of alcohol or drugs.
- Slow down and use caution when making turns and crossing roads and sidewalks. Stop blades if not mowing.
- Use care when loading or unloading the machine into a trailer or truck.
- Use care when approaching blind corners, shrubs, trees or other objects that may obscure vision.

SLOPE OPERATION

Slopes are a major factor related to loss-of-control and tip-over accidents, which can result in severe injury or death. All slopes require extra caution. If you cannot back up the slope or if you feel uneasy on it, do not drive on it.

Do

- Mow across the face of slopes; never up and down.
- Remove obstacles such as rocks, tree limbs, etc.
- Watch for holes, ruts, or bumps. Uneven terrain could overturn the unit. Tall grass can hide obstacles.
- Use slow speed. Choose a slow speed so that you will not have to stop or change speed while on the slope.
- Use extra care with grass catchers or other attachments. These can change the stability of the unit.
- Keep all movement on the slopes slow and gradual. Do not make sudden changes in speed or direction.
- See your authorized dealer for recommendations of available weights to improve stability.

WARNING

Never operate on slopes greater than 20° (36.4 percent) which is a rise of 7-1/4 feet (220 cm) vertically in 20 feet (607 cm) horizontally.

Select slow ground speed before driving onto slope. In addition to front and rear weights, use extra caution when operating on slopes with rear-mounted grass catcher.

Mow ACROSS the slope, never up and down the face, use caution when changing directions and **DO NOT START OR STOP ON SLOPE.**

Do Not

- *Do not* start or stop on a slope. If tires lose traction, disengage the blade(s) and proceed slowly straight down the slope.
- *Do not* turn on slopes unless necessary, and then, turn slowly and gradually downhill, if possible.
- *Do not* mow near drop-offs, ditches, or embankments. The operator could lose footing or balance or mower could suddenly turn over if a wheel is over the edge of a cliff or ditch, or if an edge caves in.
- *Do not* mow on wet grass. Reduced footing or traction could cause sliding.
- *Do not* try to stabilize the unit by putting your foot on the ground.
- *Do not* mow excessively steep slopes.
- *Do not* use grass catcher on steep slopes.

CHILDREN

Tragic accidents can occur if the operator is not alert to the presence of children. Children are often attracted to the unit and the mowing activity. Never assume that children will remain where you last saw them.

- Keep children out of the mowing area and under the watchful care of another responsible adult.
- Be alert and turn unit off if children enter the area.
- Before and during reverse operation, look behind and down for small children.
- Never carry children. They may fall off and be seriously injured or interfere with safe unit operation.
- Never allow children to operate the unit.
- Use extra care when approaching blind corners, shrubs, trees, or other objects that may obscure vision.

EMISSIONS

- Engine exhaust from this product contains chemicals known, in certain quantities, to cause cancer, birth defects, or other reproductive harm.
- Look for the relevant Emissions Durability Period and Air Index information on the engine emissions label.

MAINTENANCE AND STORAGE

- Always observe safe refueling and fuel handling practices when refueling the unit after transportation or storage.
- Always follow the engine manual instructions for storage preparations before storing the unit for both short and long term periods.
- Always follow the engine manual instructions for proper start-up procedures when returning the unit to service.
- Never store the machine or fuel container inside where there is an open flame, such as in a water heater. Allow unit to cool before storing.
- Shut off fuel while storing or transporting. Do not store fuel near flames or drain indoors.
- Keep all hardware, especially blade attachment bolts, tight and keep all parts in good working condition. Replace all worn or damaged decals.
- Never tamper with safety devices. Check their proper operation regularly.
- Clean grass and debris from cutting units, drives, mufflers, and engine to prevent fires. Clean up oil or fuel spillage.
- Stop and inspect the equipment if you strike an object. Repair, if necessary, before restarting.
- Never make adjustments or repairs with the engine running unless specified otherwise.
- Park machine on level ground. Never allow untrained personnel to service machine.
- Use jack stands to support components when required.
- Carefully release pressure from components with stored energy. (eg. springs)
- Disconnect battery or remove spark plug wire before making any repairs. Disconnect the negative terminal first and the positive last. Reconnect positive first and negative last.
- Use care when checking blades. Wrap the blade(s) or wear gloves, and use caution when servicing them. Only replace blades. Never straighten or weld them.
- Keep hands and feet away from moving parts.
- Charge batteries in an open well ventilated area, away from spark and flames. Unplug charger before connecting or disconnecting from battery. Wear protective clothes and use insulated tools.
- Grass catcher components are subject to wear, damage, and deterioration, which could expose moving parts or allow objects to be thrown. Frequently check components and replace with manufacturer's recommended parts, when necessary.
- Check brake operation frequently. Adjust and service as required.
- Use only factory authorized replacement parts when making repairs.
- Always comply with factory specifications on all settings and adjustments.
- Only authorized service locations should be utilized for major service and repair requirements.
- Never attempt to make major repairs on this unit unless you have been properly trained. Improper service procedures can result in hazardous operation, equipment damage and voiding of manufacturer's warranty.

Safety Decals

GENERAL

This unit has been designed and manufactured to provide you with the safety and reliability you would expect from an industry leader in outdoor power equipment manufacturing.

Although reading this manual and the safety instructions it contains will provide you with the necessary basic knowledge to operate this equipment safely and effectively, we have placed several safety labels on the unit to remind you of this important information while you are operating your unit.

All DANGER, WARNING, CAUTION and instructional messages on your mower should be carefully read and obeyed. Personal bodily injury can result when these instructions are not followed. The information is for your safety and it is important.

The safety decals below are on your unit.

If any of these decals are lost or damaged, replace them at once. See your local dealer for replacements.

These labels are easily applied and will act as a constant visual reminder to you, and others who may use the equipment, to follow the safety instructions necessary for safe, effective operation.

NOTE: Engine operation and safety decals are supplied by the engine manufacturer.

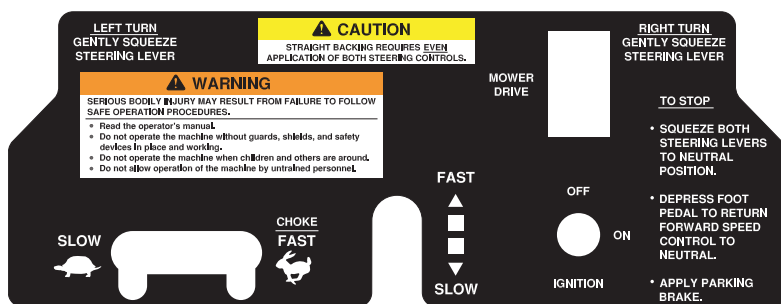

**Dash Panel Decal
Part No. 22325**

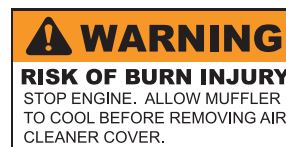

**Warning Decal
Part No. 22189**



**Danger Decal
Part No. 1704276**



**Danger Decal
Part No. 1704277**



**Warning Decal
Part No. 21818**



**Warning Decal
Part No. 21818**



**Warning Decal
Part No. 21159**

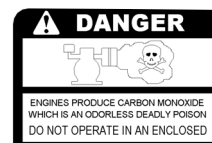

**Danger Decal
Part No. 21411**

Features & Controls of the Dual Drive Walk-Behind

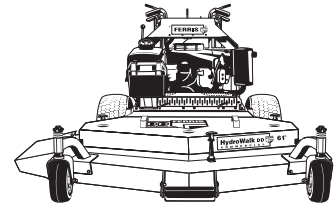

Please take a moment and familiarize yourself with the name, location, and function of these controls so that you will better understand the safety and operating instructions provided in this manual.

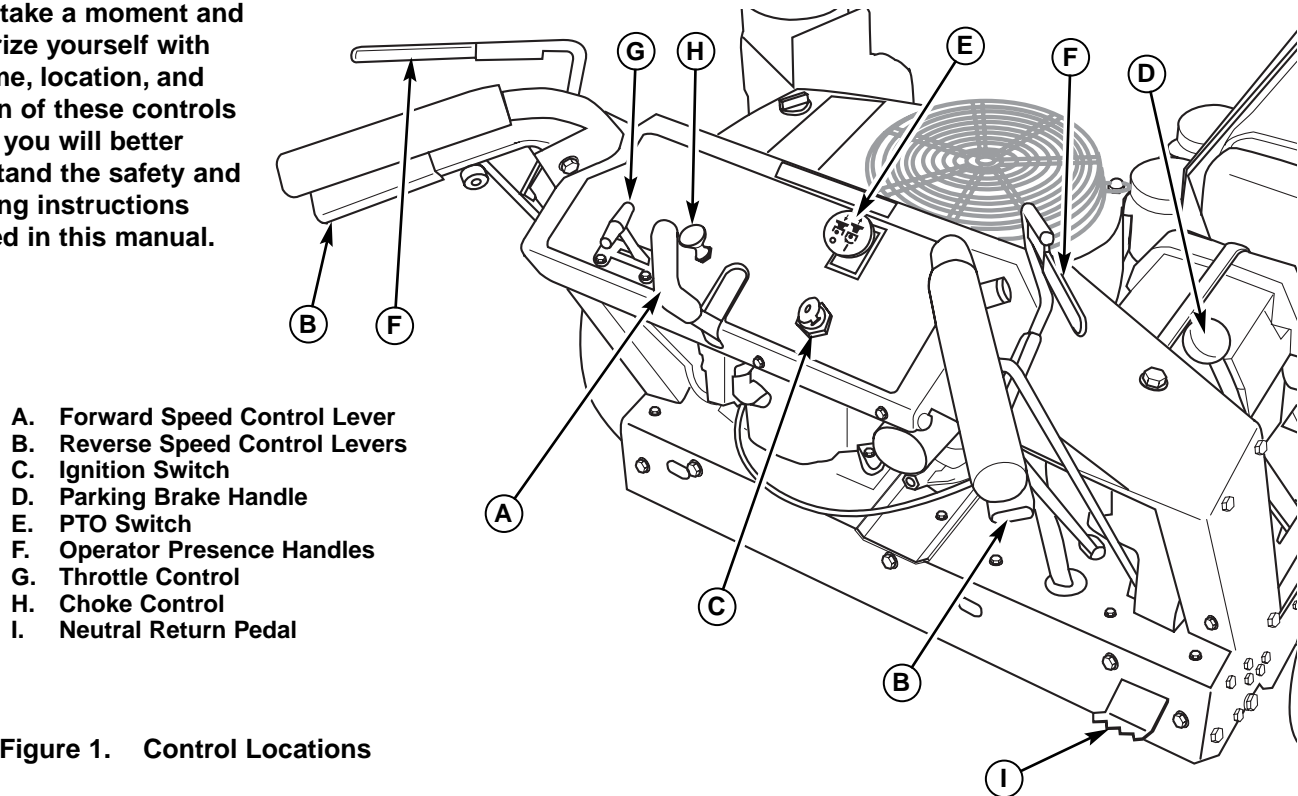

- A. Forward Speed Control Lever
- B. Reverse Speed Control Levers
- C. Ignition Switch
- D. Parking Brake Handle
- E. PTO Switch
- F. Operator Presence Handles
- G. Throttle Control
- H. Choke Control
- I. Neutral Return Pedal

Figure 1. Control Locations

CONTROL FUNCTIONS

The information below briefly describes the function of individual controls. Starting, stopping, driving, and mowing require the combined use of several controls applied in specific sequences. To learn what combination and sequence of controls to use for various tasks see the OPERATION section.

A & B. Forward Speed Control Lever / Reverse Speed Control Levers

These levers control the ground speed of the mower.

The center lever (A) control the forward ground speed of both drive wheels.

The left lever controls the steering and reverse ground speed of the left drive wheel and the right lever controls the steering and reverse ground speed of the right drive wheel.

NOTE: The further a lever is moved away from the neutral position the faster the drive wheel will turn.

See the Operating the Dual Drive Walk-Behind Mower section for steering instructions.

C. Ignition Switch

The ignition switch starts and stops the engine, it has three positions:

- OFF Stops the engine and shuts off the electrical system.
- RUN Allows the engine to run and powers the electrical system.
- START Cranks the engine for starting.

NOTE: Never leave the ignition switch in the RUN position with the engine stopped—this drains the battery.

D. Parking Brake Handle

The parking brake is applied by pushing DOWN on the parking brake handle until it stops. To release the parking brake, pull UP on the handle until it locks over center.

E. PTO (Power Take Off) Switch

The PTO switch engages and disengages the mower. Pull UP on the switch to engage, and push DOWN to disengage.

F. Operator Presence Handles

These handles are a major factor in the safety interlock system of the mower. Both handles are tied together so depressing one handle depresses both. The operator must depress the handles in order to disengage the parking brake and engage the PTO switch.

G & H. Throttle / Choke Control

Pulling the round choke control knob (H) out fully chokes the engine for cold starts. (A warm engine may not require choking.) Moving the throttle control (G) fully towards the right is FULL throttle position. Always operate the unit at FULL throttle when mowing.

I. Neutral Return Pedal

The neutral return pedal provides a hands-free return to neutral. This is used in conjunction with the Reverse Speed Control Levers (B) to properly stop the machine.

See the Operating the Dual Drive Walk-Behind Mower section for steering instructions.

J. Fuel Shut Off Valve (not shown)

The fuel shut off valve is located under the fuel tank. Turning the handle until it is VERTICAL will allow fuel to be supplied to the engine. Turning the handle until it is HORIZONTAL shuts off the fuel supply to the engine.



SAFETY INTERLOCK SYSTEM

This unit is equipped with safety interlock switches. These safety systems are present for your safety, do not attempt to bypass safety switches, and never tamper with safety devices. Check their operation regularly.

Operational SAFETY Checks

Test 1 — Engine should NOT crank if:

- PTO switch is engaged, OR
- Parking brake is not engaged, OR
- Motion control handle is not in the NEUTRAL position

Test 2 — Engine SHOULD crank if:

- PTO switch is NOT engaged, AND
- Parking brake is engaged, AND
- Motion control handle is in the NEUTRAL position

Test 3 — Engine should SHUT OFF if:

- Operator releases the operator presence handles with PTO engaged, OR
- Operator releases the operator presence handles with parking brake disengaged.

Test 4 — Blade Brake Check

Mower blades and mower drive belt should come to a complete stop within seven seconds after electric PTO switch is turned off (or operator releases the operator presence handles). If mower drive belt does not stop within seven seconds, see your dealer.

NOTE: Once the engine has stopped, PTO switch must be turned off, parking brake must be engaged, and the motion control handle must be returned to the NEUTRAL position in order to start the engine.

WARNING

If the unit does not pass a safety test, do not operate it. See your authorized dealer. Under no circumstance should you attempt to defeat the purpose of the safety interlock system.

Operating the Dual Drive Walk-Behind

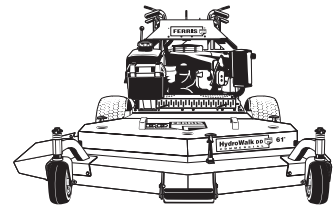

GENERAL OPERATING SAFETY

Before first time operation:

- Be sure to read all information in the Safety and Operation sections before attempting to operate this tractor and mower.
- Become familiar with all of the controls and how to stop the unit.
- Drive in an open area without mowing to become accustomed to the unit.

! WARNING

Before leaving the operator's position for any reason, engage the parking brake, disengage the PTO, stop the engine and remove the key.

To reduce fire hazard, keep the engine, tractor and mower free of grass, leaves and excess grease. Do not stop or park tractor over dry leaves, grass or combustible materials.

Gasoline is highly flammable and must be handled with care. Never fill the tank when the engine is still hot from recent operation. Do not allow open flame, smoking or matches in the area. Avoid over-filling and wipe up any spills.

CHECKS BEFORE STARTING

- Check that crankcase is filled to full mark on dipstick. See the engine Operator's Manual for instructions and oil recommendations.
- Make sure all nuts, bolts, screws and pins are in place and tight.
- Fill the fuel tank with fresh fuel. Refer to engine manual for fuel recommendations.

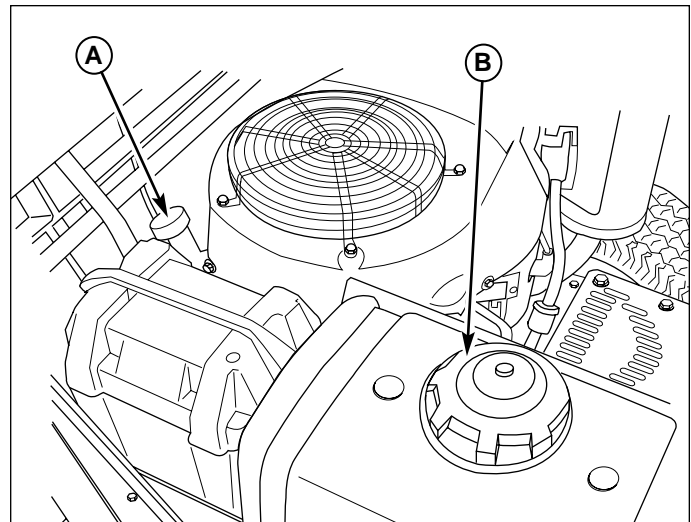

Figure 2. Pre-start Checks

- A. Crankcase Oil Fill
- B. Fuel Tank Filler Neck

WARNING

If you do not understand how a specific control functions, or have not yet thoroughly read the **FEATURES & CONTROLS** section, do so now.

Do **NOT** attempt to operate the tractor without first becoming familiar with the location and function of **ALL** controls.

STARTING THE ENGINE

1. Engage the parking brake and make sure the PTO switch is disengaged and the motion control lever is in the NEUTRAL position.
2. Set the engine throttle control (G, Figure 1) to FAST throttle position. Then fully close the choke (H, Figure 1) by pulling the knob OUT fully.

NOTE: A warm engine may not require choking.

- 3A. Insert the key into the ignition switch (C, Figure 1) and turn it to the RUN position (15hp & 17hp models). Firmly and sharply pull the recoil until the engine starts.
- 3B. Insert the key into the ignition switch (C, Figure 1) and turn it to the START position (23hp model).
4. After the engine starts, gradually open the choke (push knob down fully).

Warm up the engine by running it for at least a minute before engaging the PTO switch or driving the mower.

5. **After warming the engine, ALWAYS operate the unit at FULL THROTTLE when mowing.**

In the event of an emergency the engine can be stopped by simply turning the ignition switch to STOP. Use this method only in emergency situations. For normal engine shut down follow the procedure given in **STOPPING THE MOWER**

STOPPING THE MOWER

1. Gently squeeze both steering control levers (B, Figure 1) evenly to stop the machine.
3. Once the machine is stopped, firmly depress the neutral return pedal (I, Figure 1) to place the transmissions in neutral.
2. Disengage the PTO by pushing down on the PTO switch (E, Figure 1).
3. Engage the parking brake by pushing the handle (D, Figure 1) forward until it stops.
4. Move the throttle control (G, Figure 1) to mid-throttle position and turn the ignition key to OFF. Remove the key.

DRIVING THE MOWER

The hydrostatic transmission has an infinite number of speeds between full speed forward and reverse, with the faster speeds being achieved by moving the speed control lever and steering control levers farthest in the direction of travel.

TO MOVE FORWARD

1. Disengage the parking brake.
2. Gently move the speed control lever forward until desired speed is achieved.

TO MOVE BACKWARD

1. Disengage the parking brake.
2. Gently squeeze both steering control levers evenly, until desired speed is achieved.

TO SLOW OR STOP MACHINE

1. Gently squeeze both steering control levers evenly to slow the machine.
2. Continuing to squeeze the steering control levers will stop the machine.
3. Once the machine is stopped, firmly depress the neutral return pedal to place the transmissions in neutral.

TO TURN MACHINE

To make a left-hand turn:

Gently squeeze the left-hand steering control lever. A sharp or gentle turn is determined by the amount of force applied to the steering control lever.

To make a right-hand turn:

Gently squeeze the right-hand steering control lever. A sharp or gentle turn is determined by the amount of force applied to the steering control lever.

NOTE: ALWAYS REDUCE SPEED IN A TURN

For normal use, the throttle should be kept fully open and the ground speed of the machine determined by the speed control lever. When transporting the machine or when loading or unloading from a truck or trailer, partial throttle should be used to slow the reaction time of the controls and reduce noise.

Practice maneuvering the machine at a slow engine speed on level ground with the blade engagement switch in the "OFF" position until you are familiar with the controls.

Operating the Dual Drive Walk-Behind

MOWING

Before mowing, set the cutting height as described in the *Troubleshooting, Adjustments & Service* section.

1. Engage the parking brake. Make sure the PTO switch is disengaged and the motion control lever is in the NEUTRAL position.
2. Start the engine (see STARTING THE ENGINE).
3. Set the throttle to FULL.
4. Engage the PTO by pulling up on the PTO switch (E, Figure 1).
5. Begin mowing. See *Lawn Care* section for tips on mowing patterns, lawn care, and trouble shooting information.
6. When finished, shut off the PTO.
7. Stop the engine (see STOPPING THE TRACTOR AND ENGINE).

PUSHING THE MOWER BY HAND



DO NOT TOW MACHINE

Towing the machine will cause hydraulic transaxle damage. Do not use another vehicle to push or pull this unit.

1. Disengage the PTO, engage the parking brake, turn the ignition OFF, and remove the key.
2. To disengage the transmissions (free-wheel position), lift the hydraulic release levers (A, Figure 3) located in front of the transmission fan screen. Lock into position shown in Figure 3.
3. Disengage the parking brake.
The mower can now be pushed by hand.
4. After moving the mower, re-engage the transmissions (drive position) by unlocking the levers and returning them to the down position. If the levers are not completely down, a partial by-pass may potentially damage the transmissions.

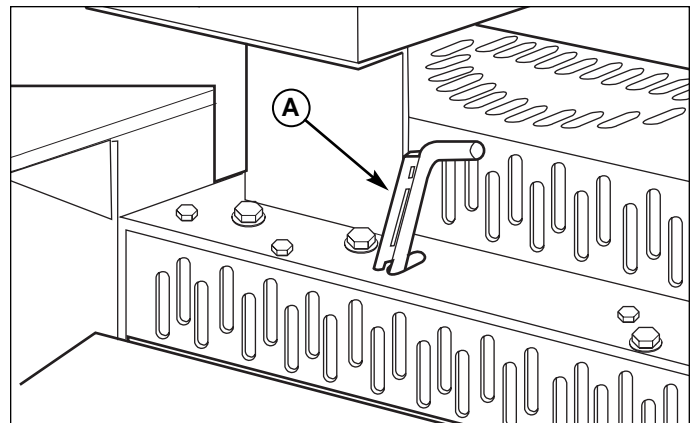

Figure 3. Hydraulic System By-Pass

A. Hydraulic Release Lever (right-hand side shown)

STORAGE

Temporary Storage (30 Days Or Less)

Remember, the fuel tank will still contain some gasoline, so never store the unit indoors or in any other area where fuel vapor could travel to any ignition source. Fuel vapor is also toxic if inhaled, so never store the unit in any structure used for human or animal habitation.

Here is a checklist of things to do when storing your unit temporarily or in between uses:

- Keep the unit in an area away from where children may come into contact with it. If there's any chance of unauthorized use, remove the spark plug (s) and put in a safe place. Be sure the spark plug opening is protected from foreign objects with a suitable cover.
- If the unit can't be stored on a reasonable level surface, chock the wheels.
- Clean all grass and dirt from the mower.

Long Term Storage (Longer Than 30 Days)

Before you store your unit for the off-season, read the Maintenance and Storage instructions in the Safety Rules section, then perform the following steps:

1. Drain crankcase oil while engine is hot and refill with a grade of oil that will be required when unit is used again.
2. Prepare the mower deck for storage as follows:
 - a. Remove mower deck from the unit.
 - b. Clean underside of mower deck.
 - c. Coat all bare metal surfaces with paint or light coat of oil to prevent rusting.
3. Clean external surfaces and engine.
4. Prepare engine for storage. See engine owner's manual.
5. Clean any dirt or grass from cylinder head cooling fins, engine housing and air cleaner element.
6. Cover air cleaner and exhaust outlet tightly with plastic or other waterproof material to keep out moisture, dirt and insects.
7. Completely grease and oil unit as outlined in the Normal Care section.
8. Clean up unit and apply paint or rust preventative to any areas where paint is chipped or damaged.
9. Be sure the battery is filled to the proper level with water and is fully charged. Battery life will be increased if it is removed, put in a cool, dry place and fully charged about once a month. If battery is left in unit, disconnect the negative cable.

WARNING

Never store the unit, with gasoline in engine or fuel tank, in a heated shelter or in enclosed, poorly ventilated enclosures. Gasoline fumes may reach an open flame, spark or pilot light (such as a furnace, water heater, clothes dryer, etc.) and cause an explosion.

Handle gasoline carefully. It is highly flammable and careless use could result in serious fire damage to your person or property.

Drain fuel into an approved container outdoors away from open flame or sparks.

10. Drain fuel system completely or add a gasoline stabilizer to the fuel system. If you have chosen to use a fuel stabilizer and have not drained the fuel system, follow all safety instructions and storage precautions in this manual to prevent the possibility of fire from the ignition of gasoline fumes. Remember, gasoline fumes can travel to distant sources of ignition and ignite, causing risk of explosion and fire.

NOTE: Gasoline, if permitted to stand unused for extended periods (30 days or more), may develop gummy deposits which can adversely affect the engine carburetor and cause engine malfunction. To avoid this condition, add a gasoline stabilizer to the fuel tank and run the engine a few minutes, or drain all fuel from the unit before placing it in storage.

STARTING AFTER LONG TERM STORAGE

Before starting the unit after it has been stored for a long period of time, perform the following steps.

1. Remove any blocks from under the unit.
2. Install the battery if it was removed.
3. Unplug the exhaust outlet and air cleaner.
4. Fill the fuel tank with fresh gasoline. See engine manual for recommendations.
5. See engine owner's manual and follow all instructions for preparing engine after storage.
6. Check crankcase oil level and add proper oil if necessary. If any condensation has developed during storage, drain crankcase oil and refill.
7. Inflate tires to proper pressure. Check fluid levels.
8. Start the engine and let it run slowly. DO NOT run at high speed immediately after starting. Be sure to run engine only outdoors or in well ventilated area.

Regular Maintenance

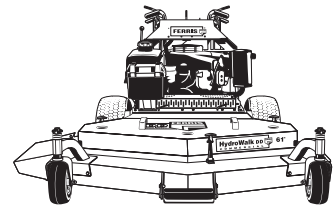

MAINTENANCE SCHEDULE & PROCEDURES

The following schedule should be followed for normal care of your mower. You will need to keep a record of your operating time.

SAFETY ITEMS	See Page	Before First Use	Before Each Use	Every 5 Hours	Every 25 Hours	Every 100 Hours	Spring & Fall
Check Safety Interlock System	9	X	X				X
Check Mower Blade Stopping Time	23	X				X	
NORMAL CARE ITEMS	See Page	Before First Use	Before Each Use	Every 5 Hours	Every 25 Hours	Every 100 Hours	Spring & Fall
Check Rider/Mower for loose hardware	—		X	X			
Check Engine Oil Level	15*	X	X	X			X
Check Engine Air Filter	15*		X			****X	
Change Engine Oil & Filter **	15*				****X Every 50 Hours		****X
Change Transmission Oil & Filters	28					****X Every 500 Hours	
Lubricate Mower & Mower Deck	16	X				****X	
Check Mower Deck Belt Tension***	24/25				X		
Check Tire Pressure	14	X				****X	
Check Hydraulic Fluid	15	X				****X	
Check Fuel Filter	15					X	
Clean Battery & Cables	17					X	
Clean & Sharpen Mower Blades	18					X	
Inspect Spark Plug	15*					X	

* See the engine manufacturer's owner's manual.

** Change original engine oil after first 5 hours of operation.

*** Check belt tension after first 5 hours of operation.

**** More often in hot (over 85° F: 30° C) weather or dusty operating conditions.

CHECK TIRE PRESSURES

Tire pressure should be checked periodically, and maintained at the levels shown in the chart. Note that these pressures may differ slightly from the "Max Inflation" stamped on the side-wall of the tires. The pressures shown provide proper traction, improve cut quality, and extend tire life.

Tire	Pressure
Front	25 psi (172 kPa)
Rear	15 psi (103 kPa)

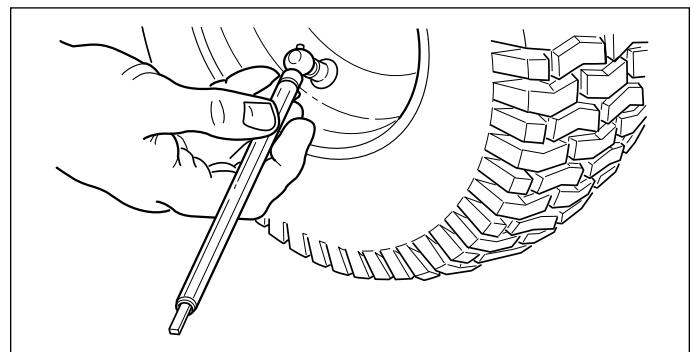

Figure 4. Checking Tire Pressure

CHECKING / ADDING FUEL

To add fuel:

1. Remove the fuel cap (see A, Figure 2).
2. Fill the tank to the bottom of the filler neck. This will allow for fuel expansion.

NOTE: Do not overfill. Refer to your engine manual for specific fuel recommendations.

3. Install and hand tighten the fuel cap.
4. Repeat same process for opposite tank.

FUEL FILTER

The fuel filter (D, Figure 2) is located in the fuel line between fuel shut off valve and carburetor, near the fuel pump. If filter is dirty or clogged, replace as follows:

1. Shut off the fuel tank selection valve.
2. Disconnect the negative battery cable.
3. Place a container below the filter to catch spilled fuel.
4. Using a pliers, open and slide hose clamps from fuel filter.
5. Remove hoses from filter.
6. Install new filter in proper flow direction in fuel line.
7. Secure with hose clamps.
8. Reconnect the negative battery cable when finished.

OIL & FILTER CHANGE

Refer to engine owners manual.

CHECK / CHANGE AIR FILTER

Refer to engine owners manual.

REPLACE SPARK PLUG

Refer to engine owners manual.

CHECK HYDRAULIC OIL LEVEL

1. Observe the oil reservoirs (B, Figure 2). The oil level should be at the "FULL" line (C, figure 2).
2. Before removing the reservoir caps, make sure the area around the reservoir cap is free of dust, dirt, or other debris.
3. If necessary, unscrew the reservoir cap and add SAE straight 20 or 30 weight motor oil. **DO NOT** use multi-grade oils. Fill until oil level reaches "FULL" line.
4. Reinstall oil reservoir caps.

WARNING

Gasoline is highly flammable and must be handled with care. Never fill the tank when the engine is still hot from recent operation. Do not allow open flame, smoking or matches in the area. Avoid over-filling and wipe up any spills.

Do not remove fuel filter when engine is hot, as spilled gasoline may ignite. **DO NOT** spread hose clamps further than necessary. Ensure clamps grip hoses firmly over filter after installation.



Do not use gasoline containing METHANOL, gasohol containing more than 10% ethanol, gasoline additives, premium gasoline, or white gas because engine/fuel system damage could result.

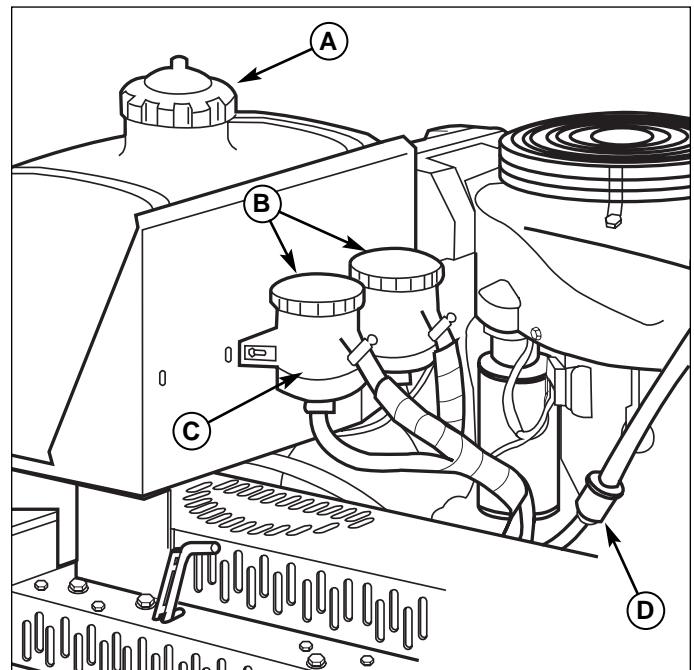

Figure 5. Fuel Tank, Oil Reservoir & Fuel Filter

- A. Fuel Cap
- B. Oil Reservoirs
- C. "FULL" Line
- D. Fuel Filter

Regular Maintenance

LUBRICATION

Lubricate the machine at the lubrication points shown in Figures 6 - 11.

Use grease fittings when present. Disassemble parts to apply grease to moving parts when grease fittings are not installed.

Not all greases are compatible. Ferris Red Grease (P/N 22285) is strongly recommended. Automotive-type high-temperature, lithium grease may be used when this is not available.

Generally, all moving metal parts should be oiled where contact is made with other parts. Keep oil and grease off belts and pulleys. Remember to wipe fittings and surfaces clean both before and after lubrication.

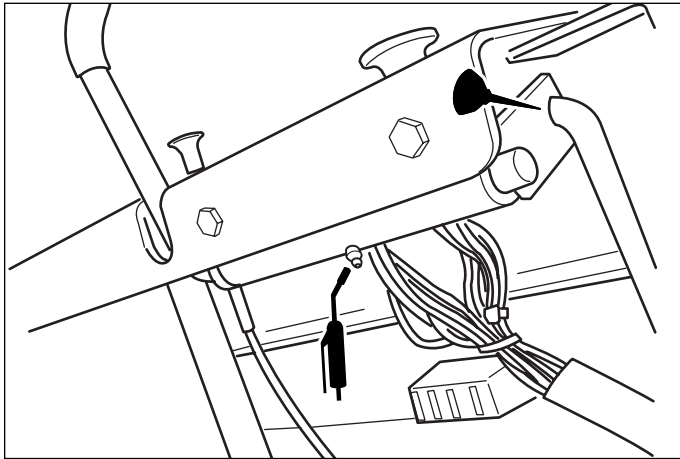

Figure 6. Motion Control Pivot & Rod Pivot

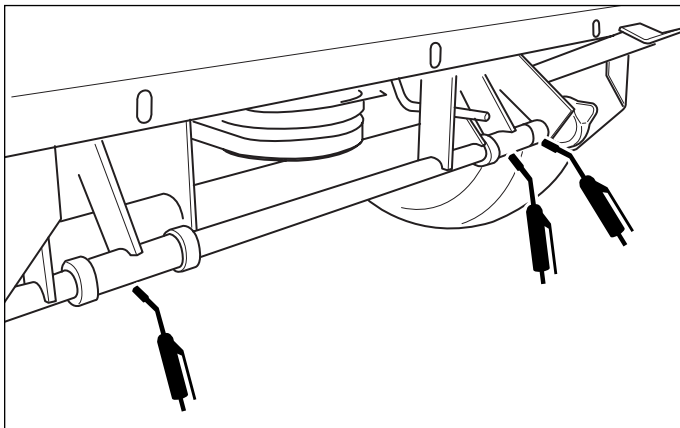

Figure 7. Lower Motion Control Pivots & Neutral Return Pedal Pivot

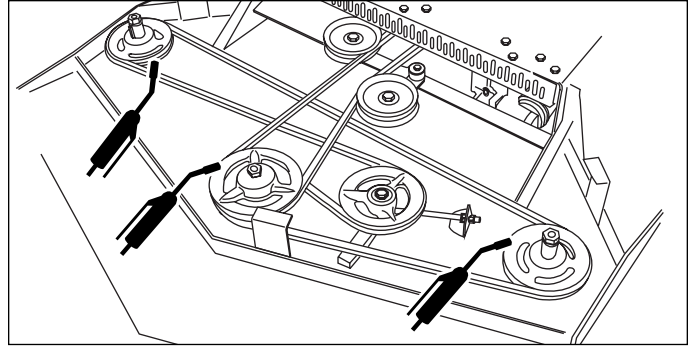

Figure 8. Blade Spindles

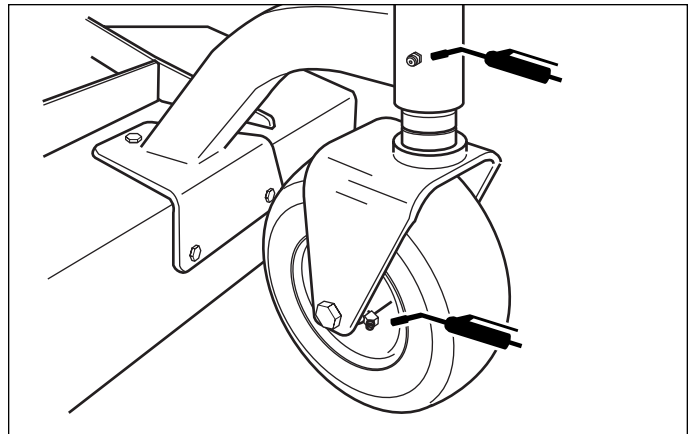

Figure 9. Caster Tire Pivots & Axles

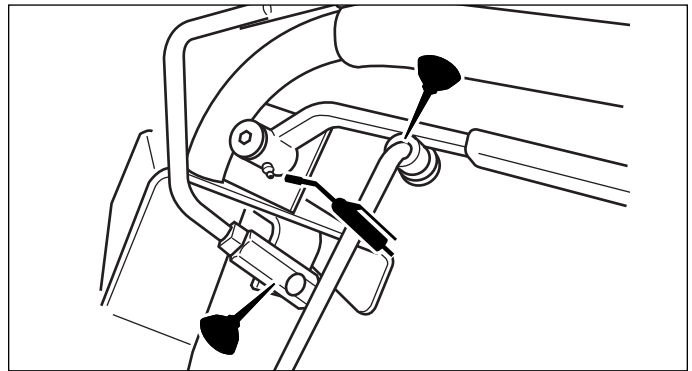

Figure 10. Steering Lever Pivots & Operator Presence Pivots

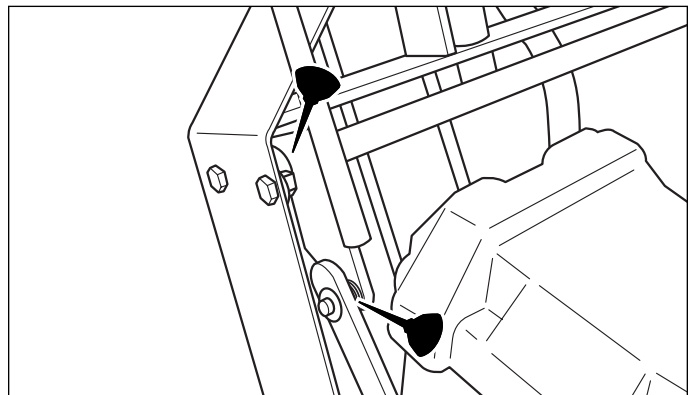

Figure 11. Parking Brake Lever Pivot & Link Pivot

BATTERY MAINTENANCE

Checking the Battery Fluid

NOTE: It is not necessary to check the battery fluid level if machine is equipped with a maintenance-free battery.

1. Remove the battery box cover to access the battery.
2. Remove the battery filler cap(s) (A, Figure 12). Fluid must be even with the split ring full mark. If not, add distilled water.
3. Reinstall the filler cap(s).

Cleaning the Battery and Cables

1. Disconnect the cables from the battery, negative cable first (C, Figure 12).
2. Clean the battery terminals and cable ends with a wire brush until shiny.
3. Reinstall the battery and reattach the battery cables, positive cable first (see B, Figure 12)
4. Coat the cable ends and battery terminals with petroleum jelly or non-conducting grease.

! WARNING

Be careful when handling the battery. Avoid spilling electrolyte. Keep flames and sparks away from the battery.

When removing or installing battery cables, disconnect the negative cable FIRST and reconnect it LAST. If not done in this order, the positive terminal can be shorted to the frame by a tool.

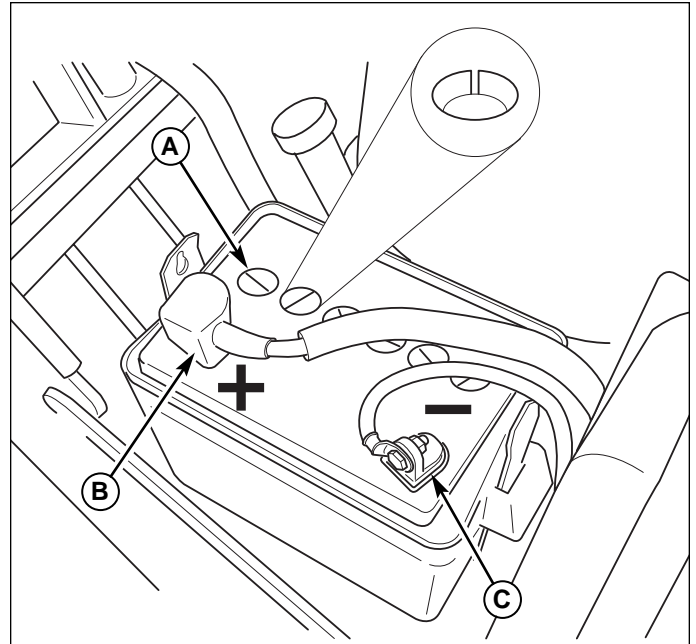

Figure 12. Battery Compartment

- A. Vent Cap(s)
- B. Positive (+) Cable & Terminal
- C. Negative (-) Cable & Terminal

Regular Maintenance

SERVICING THE MOWER BLADES

1. Blades should be sharp and free of nicks and dents. If not, sharpen blades as described in following steps.
2. Remove the deck guard.
3. Raise the mower deck and secure with jackstands.
4. To remove blade for sharpening, use two (2) 15/16" wrenches to remove the nut from the top of the blade bolt. (Figure 13).
5. Use a file or hand-held grinder, sharpen blade to fine edge. Remove all nicks and dents in blade edge. If blade is severely damaged, it should be replaced.
6. Balance the blade as shown in Figure 14. Center the blade's hole on a nail lubricated with a drop of oil. A balanced blade will remain level.
7. Reinstall each blade with the tabs pointing up toward deck as shown in Figure 15. The blade spacers, blade, washer and bolt must be reinstalled in the exact same order in which they were removed. Torque bolts to 70-90 ft.lbs. (94-120 N.m.).

! WARNING

For your personal safety, blade mounting bolts must each be installed with a flat washer then securely tightened. Torque blade mounting bolts to 70-90 ft.lbs. (94-120 N.m.)

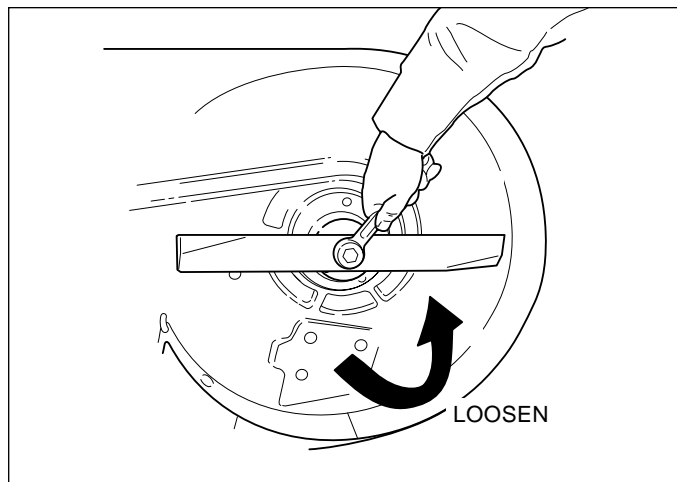

Figure 13. Removing the Blade

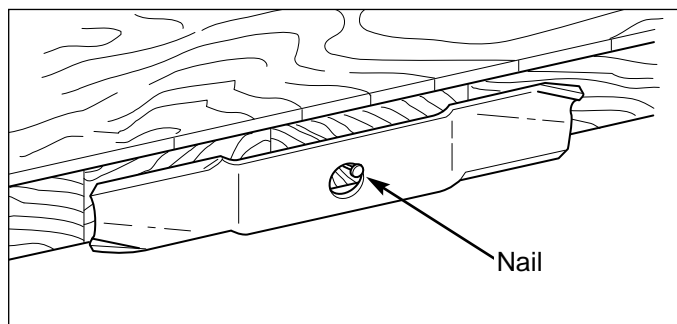

Figure 14. Balancing the Blade

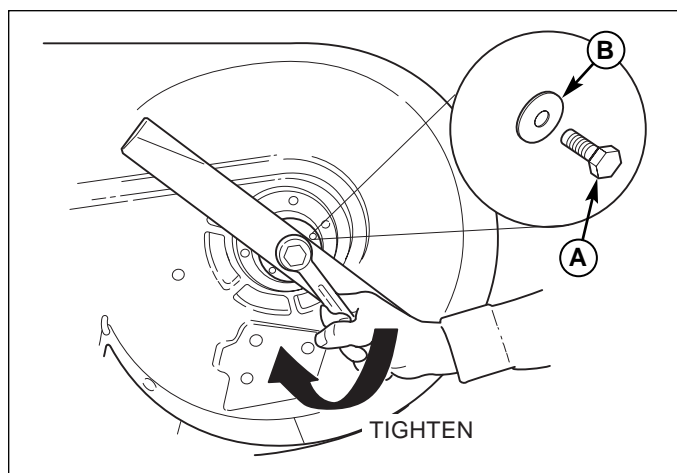

Figure 15. Installing the Blade

- A. Bolt
- B. Flat Washer

Troubleshooting Adjustments & Service

TROUBLESHOOTING

While normal care and regular maintenance will extend the life of your equipment, prolonged or constant use may eventually require that service be performed to allow it to continue operating properly.

The troubleshooting guide below lists the most common problems, their causes and remedies.

See the information on the following pages for instructions on how to perform most of these minor adjustments and service repairs yourself. If you prefer, all of these procedures can be performed for you by your local authorized dealer.

WARNING

To avoid serious injury, perform maintenance on the mower only when the engine is stopped and the parking brake engaged.

Always remove the ignition key, disconnect the spark plug wire and fasten it away from the plug before beginning the maintenance, to prevent accidental starting of the engine.

TROUBLESHOOTING THE MOWER

PROBLEM	CAUSE	REMEDY
Engine will not turnover or start.	<ol style="list-style-type: none"> 1. Parking brake not engaged. 2. PTO (electric clutch) switch in ON position. 3. Out of fuel. 4. Engine flooded. 5. Fuse blown. 6. Battery terminals require cleaning. 7. Battery discharged or dead. 8. Wiring loose or broken. 9. Solenoid or starter motor faulty. 10. Safety interlock switch faulty. 11. Spark plug(s) faulty, fouled or incorrectly gapped. 12. Water in fuel. 13. Gas is old or stale. 	<ol style="list-style-type: none"> 1. Engage parking brake. 2. Place in OFF position. 3. If engine is hot, allow it to cool, then refill the fuel tank. 4. Move throttle control out of CHOKE position. 5. Replace fuse. 6. Clean the battery terminals 7. Recharge or replace. 8. Visually check wiring & replace broken or frayed wires. Tighten loose connections. 9. Repair or replace. See authorized service dealer 10. Replace as needed. See authorized service dealer. 11. Clean and gap or replace. See engine manual. 12. Drain fuel & refill with fresh fuel. 13. Drain fuel & replace with fresh fuel.
Engine starts hard or runs poorly.	<ol style="list-style-type: none"> 1. Fuel mixture too rich. 2. Spark plug faulty, fouled, or incorrectly gapped. 	<ol style="list-style-type: none"> 1. Clean air filter. Check choke adjustment (throttle control). 2. Clean and gap or replace. (See engine manual.)
Engine knocks.	<ol style="list-style-type: none"> 1. Low oil level. 2. Using wrong grade oil. 	<ol style="list-style-type: none"> 1. Check/add oil as required. 2. See engine manual.
Excessive oil consumption.	<ol style="list-style-type: none"> 1. Engine running too hot. 2. Using wrong weight oil. 3. Too much oil in crankcase. 	<ol style="list-style-type: none"> 1. Clean engine fins, blower screen and air cleaner. 2. See engine manual. 3. Drain excess oil.
Engine exhaust is black.	<ol style="list-style-type: none"> 1. Dirty air filter. 2. Engine choke control is in closed position. 	<ol style="list-style-type: none"> 1. Replace air filter. See engine manual. 2. Open choke control.

Troubleshooting, Adjustment & Service

Rider Troubleshooting Continued.

PROBLEM	CAUSE	REMEDY
Engine runs, but mower will not drive.	<ol style="list-style-type: none"> 1. Transmission release lever(s) in "neutral" position. 2. Belt is broken. 3. Drive belt slips. 4. Brake is not fully released. 	<ol style="list-style-type: none"> 1. Move into drive position. 2. See Drive Belt Replacement. 3. See problem and cause below. 4. See authorized service dealer
Transmission drive belt slips.	<ol style="list-style-type: none"> 1. Pulleys or belt greasy or oily. 2. Belt stretched or worn. 	<ol style="list-style-type: none"> 1. Clean as required. 2. Replace belt.
Brake will not hold.	<ol style="list-style-type: none"> 1. Internal brake disc on transaxle worn. 	<ol style="list-style-type: none"> 1. See authorized service dealer
Mower steers hard or handles poorly.	<ol style="list-style-type: none"> 1. Steering linkage is loose. 2. Improper tire inflation. 	<ol style="list-style-type: none"> 1. Check and tighten any loose connections. 2. See Regular Maintenance Section.

TROUBLESHOOTING THE MOWER DECK

PROBLEM	CAUSE	REMEDY
Mower cut is uneven.	<ol style="list-style-type: none"> 1. Mower not leveled properly. 2. Drive tires not inflated equally or properly. 	<ol style="list-style-type: none"> 1. See Mower Adjustment. 2. See Regular Maintenance Section.
Mower cut is rough looking.	<ol style="list-style-type: none"> 1. Engine speed too slow. 2. Ground speed too fast. 3. Blades are dull. 4. Mower drive belt slipping because it is oily or worn. 5. Blades not properly fastened to arbors. 	<ol style="list-style-type: none"> 1. Set throttle to full. 2. Decrease Ground Speed. 3. Sharpen or replace blades. See Mower Blade Service. 4. Clean or replace belt as necessary. 5. See Servicing the Mower Blades.
Engine stalls easily with mower engaged.	<ol style="list-style-type: none"> 1. Engine speed too slow. 2. Ground speed too fast. 3. Cutting height set too low. 4. Discharge chute jamming with cut grass. 	<ol style="list-style-type: none"> 1. Set to full throttle. 2. Decrease Ground Speed. 3. Cut tall grass at maximum cutting height during first pass. 4. Cut grass with discharge pointing toward previously cut area.
Excessive mower vibration.	<ol style="list-style-type: none"> 1. Blade mounting screws are loose. 2. Mower blades, arbors, or pulleys are bent. 3. Mower blades are out of balance. 4. Belt installed incorrectly. 	<ol style="list-style-type: none"> 1. Tighten to 70-90 ft.lbs. (94-120 N.m.). 2. Check and replace as necessary. 3. Remove, sharpen, and balance blades. See Maintenance Section. 4. Reinstall Correctly.
Excessive belt wear or breakage.	<ol style="list-style-type: none"> 1. Bent or rough pulleys. 2. Using incorrect belt. 	<ol style="list-style-type: none"> 1. Repair or replace. 2. Replace with correct belt.
Mower drive belt slips or fails to drive.	<ol style="list-style-type: none"> 1. Belt tension improperly adjusted. 1. Idler pulley spring broken or not properly adjusted. 2. Mower drive belt broken. 	<ol style="list-style-type: none"> 1. Adjust belt tension. See Belt Replacement 1. Repair or adjust as needed. 2. Replace drive belt.

MOWING HEIGHT ADJUSTMENT

The mowing height is determined by three factors: the mount position of the mower deck, the number of blade spacers above the spindle and the number of caster spacers above the caster arm.

Refer to the *Height Of Cut* chart to the right for the correct settings to obtain the desired height of cut. Remember, the “Blade Spacers” and “Caster Spacers” columns refer to the number ABOVE the spindle and caster arm. See Figure 16.

Height Of Cut	Mount Position (C, Fig. 16)	Blade Spacers (B, Fig. 16)	Caster Spacers (A, Fig. 16)
1-3/4"	U	1	3
2"	U	2	3
2-1/4"	U	3	3
2-1/2"	U	3	2
2-3/4"	L	4	2
3"	L	2	1
3-1/4"	L	3	1
3-1/2"	L	3	0
3-3/4"	L	4	0
4"	L	5	0

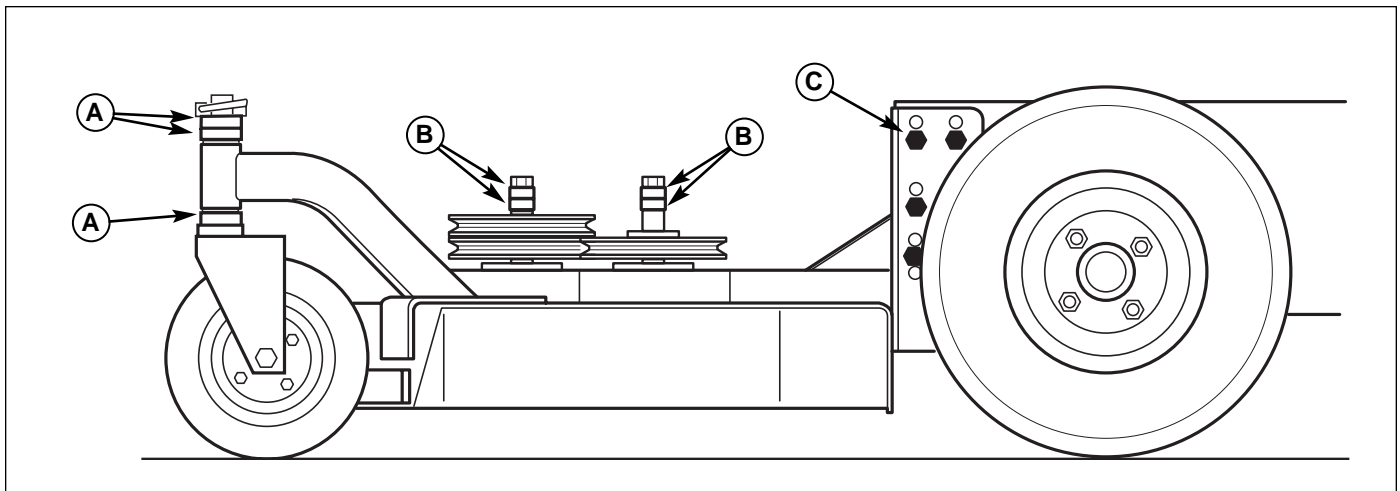

Figure 16. Mowing Height Adjustment Points

- A. Caster Spacers
- B. Blade Spacers
- C. Deck Mount Position (shown in "L")

DECK LEVELING ADJUSTMENT (DDSH Models only)

1. Make sure there is one spacer above and below the frame on the front caster shafts and place hairpin clips in the 2" cutting height position (see Figure 17).
2. Rotate the blade on the RIGHT-HAND side (discharge side) until the tip faces the front of the machine.

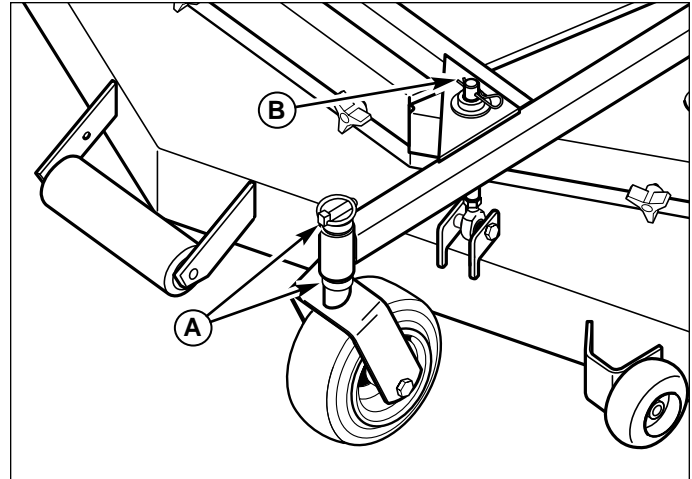

Figure 17. Caster Spacers & Hairpin Clip

- A. Caster Spacer
- B. Hairpin Clip

3. Loosen the jam nuts (A, Figure 18) located on the front deck hanger shafts (B, Figure 18). Turn the right side shaft until a cutting height of 2" is obtained at the very tip of the blade towards the front of the machine.

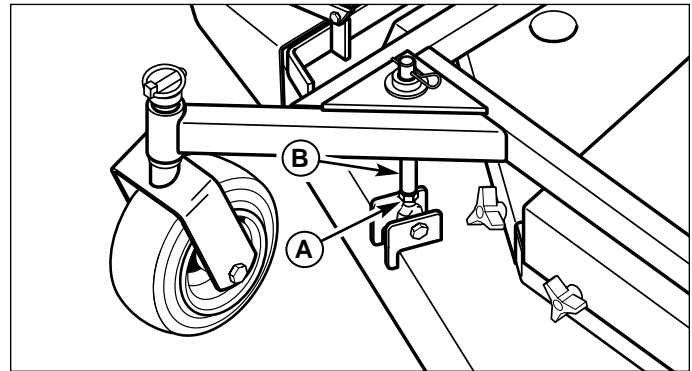

Figure 18. Front Hanger Shaft Adjustment

- A. Jam Nut
- B. Front Hanger Shaft

4. Now place a straight edge on top of the cutter deck approximately 1" to the outside of the front deck mount on the right side and measure to the floor (see Figure 19). Record your measurement.
5. Repeat the measuring procedure listed in Step 4 for the left-hand side of the mower deck.
6. Compare the measurements taken in Step 4 & 5. If they differ by more than 1/16", the front deck hanger shaft on the LEFT side (non-discharge side) must be adjusted.
7. Adjust the two front hanger shafts as needed until the tip of the blade is 2" from the floor and the measurements taken from the top of the deck to the floor are within 1/16" of each other.
8. Once the level of the deck has been adjusted, there should be no slack in the front hanger shafts. If one shaft moves, a shim (P/N 20928) is required.

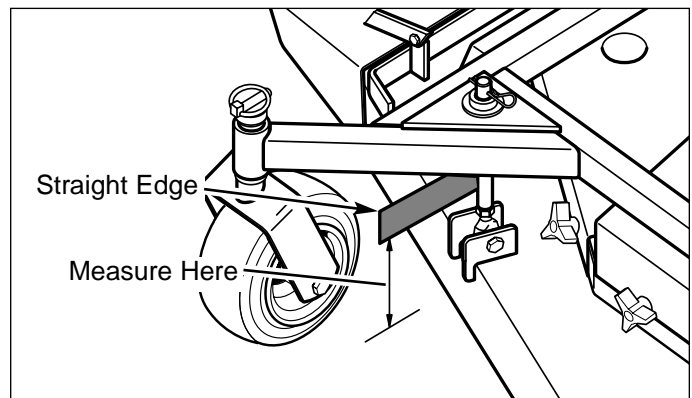

Figure 19. Mowing Height Measurement

Shimming the Hanger Shafts

Once it has been determined that a shim (P/N 20928) is required, you first must determine which rear hanger shaft requires the shim.

The shim (A, Figure 20) must be placed in between the spacer (B, Figure 20) and the retaining collar (C, Figure 20) on the OPPOSITE side from which the front shaft has movement or slack (see Figure 21).

Once the shim has been assembled in the proper location, repeat Step 2 - 8 in the *DECK LEVELING ADJUSTMENT* section. This adjustment may need to be repeated more than once until the proper number of shims has been installed to obtain the proper cutting height, equal measurements from side to side and no movement of the front hanger shafts.

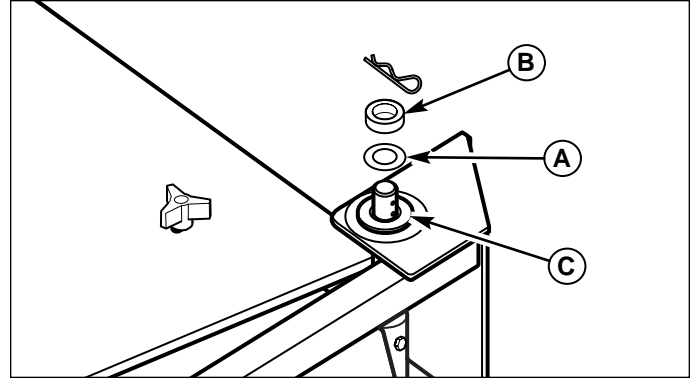

Figure 20. Shim Assembly Position

- A. Shim
- B. Spacer
- C. Retaining Collar

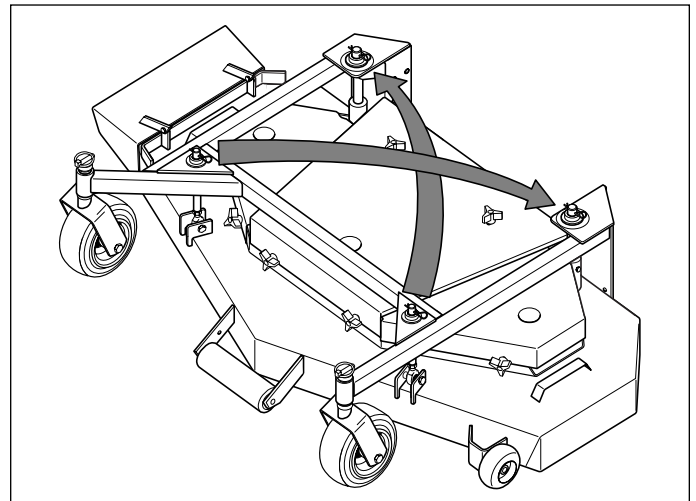

Figure 21. Proper Shim Location

MOWING HEIGHT ADJUSTMENT (DDSH Models only)

Refer to the Height Selection decal (A, Figure 22) located on the deck hanger frame and adjust the positions of the caster spacers and hairpins to obtain the desired mowing height. Perform adjustment to all four shafts.

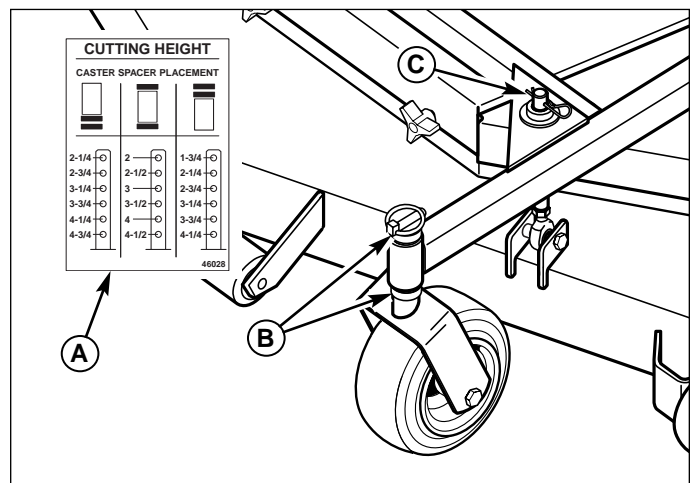

Figure 22. Mowing Height Adjustment

- A. Height Selection Decal
- B. Caster Spacer
- C. Hairpin Clip

MOWER BELT REPLACEMENT AND ADJUSTMENT



To avoid damaging belts, DO NOT PRY BELTS OVER PULLEYS.

PTO Clutch to Deck Belt

1. Park the machine on a smooth, level surface such as a concrete floor. Disengage the PTO, engage the parking brake, turn off the engine, and remove the ignition key.
2. Remove the mower deck guard.
3. Remove the rear engine deck guard.
4. Loosen the wing nut (C, Figure 23) to release the belt tension on the deck drive belt (B, Figure 23).
5. Slide the drive belt over the edge of the spindle pulley and then slide the belt around the idler pulley. Drop the belt from the PTO clutch pulley groove.
6. Remove the old belt and replace with a new one. Make sure the V-side of the belt runs in the pulley grooves.
7. Install the drive belt on the PTO pulley, the idler pulley and center spindle pulley. Tighten the wing nut (C, Figure 23) until a 10 lb. (44.5 newton) force is required to deflect the belt 1/2" (1,27cm) between the idler pulley and center spindle pulley. Jam hex nut (D, Figure 23) against anchor. See Figure 23.
8. Run the mower under no-load condition for about 5 minutes to break-in the new belt and re-check belt tension. Adjust if necessary.

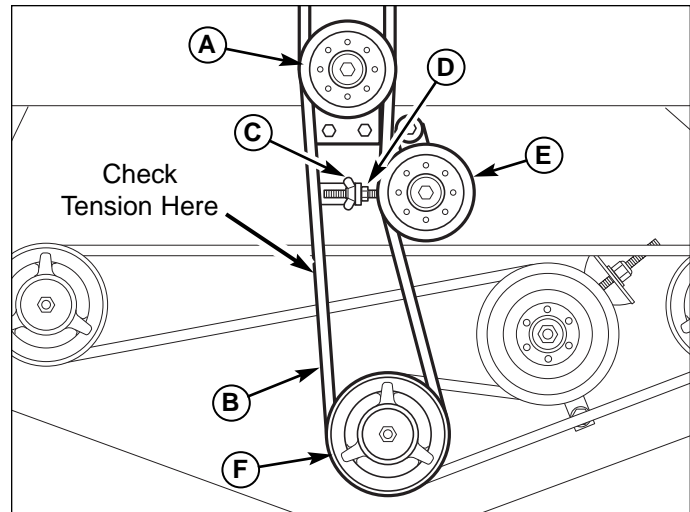

Figure 23. PTO Clutch to Deck Belt

- | | |
|----------------------------|----------------------------|
| A. Stationary Idler Pulley | D. Hex Nut |
| B. Deck Drive Belt | E. Adjustable Idler Pulley |
| C. Wing Nut | F. Center Spindle Pulley |

Spindle Belt

1. Remove PTO clutch to Deck belt. See instructions above.
2. Loosen the nylon nut (C, Figure 24) to release the belt tension on the spindle drive belt (B, Figure 24).
3. Slide the drive belt over the edge of one of the spindle pulleys and then slide the belt around the idler pulley and remaining spindle pulleys.
4. Remove the old belt and replace with a new one. Make sure the V-side of the belt runs in the pulley grooves (for single v-section belts).
5. Install the spindle drive belt on the spindle pulleys and the idler pulley. Tighten the nylon nut (C, Figure 24) until a 10 lb. (44.5 newton) force is required to deflect the belt 1/2" (1,27cm) between the idler pulley and right-hand spindle pulley. See Figure 24.
6. Run the mower under no-load condition for about 5 minutes to break-in the new belt and re-check belt tension. Adjust if necessary.

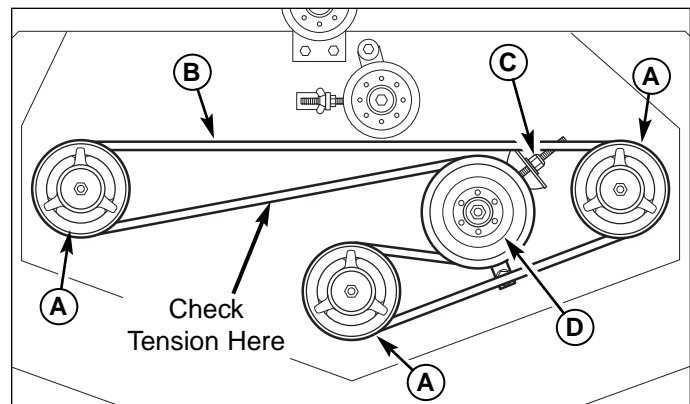

Figure 24. Spindle Drive Belt

- | |
|-----------------------|
| A. Spindle Pulley |
| B. Spindle Drive Belt |
| C. Nylon Lock Nut |
| D. Idler Pulley |

MOWER BELT REPLACEMENT AND ADJUSTMENT (DDSH Models only)



To avoid damaging belts, DO NOT PRY BELTS OVER PULLEYS.

1. Park the machine on a smooth, level surface such as a concrete floor. Disengage the PTO, engage the parking brake, turn off the engine, and remove the ignition key.
2. Remove the mower deck guard.
3. Remove the rear engine deck guard.
4. Loosen the spring compression nut (B, Figure 25 & 26) to release the belt tension.
5. Slide the drive belt over the edge of the idler pulley and then slide the belt under the idler pulley. Drop the belt from the PTO clutch pulley groove.
6. Remove the old belt and replace with a new one. Make sure the V-side of the belt runs in the pulley grooves (Figure 27).
7. Install the drive belt on the PTO pulley, the spindle pulleys and idler pulleys. Tighten the spring compression nut (B, Figure 25 & 26) until the belt tension spring (A, Figure 25 & 26) is 3/4" (1,90cm) long.
8. Run the mower under no-load condition for about 5 minutes to break-in the new belt and re-check spring length. Adjust if necessary.

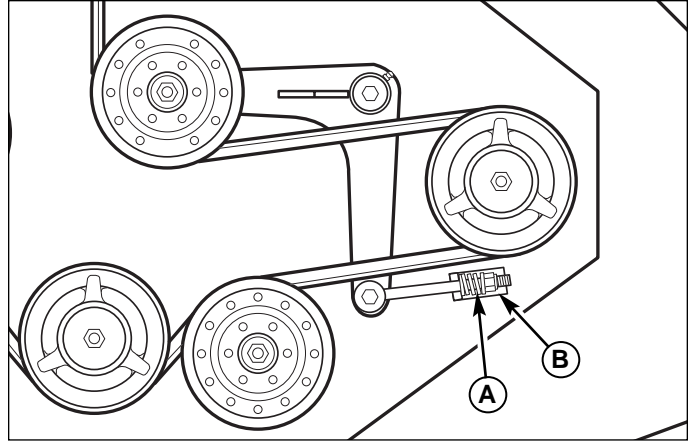

Figure 25. 52" Mower PTO Belt

- A. Belt Tension Spring
- B. Spring Compression Nut

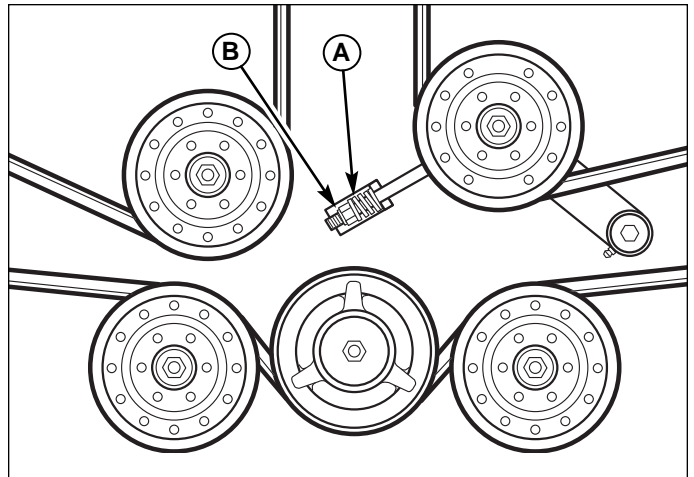

Figure 26. 61" Mower PTO Belt

- A. Belt Tension Spring
- B. Spring Compression Nut

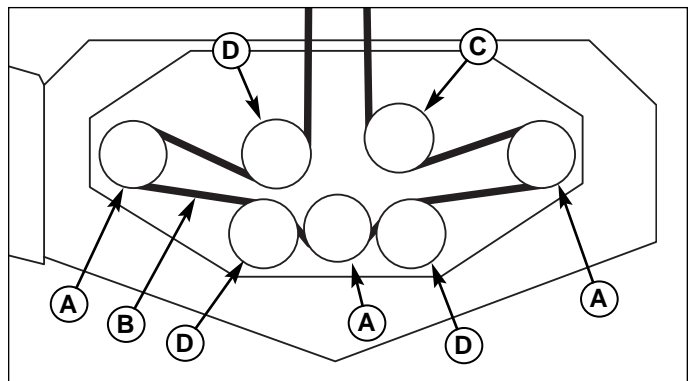

Figure 27. Mower PTO Belt Routing

- A. Spindle Pulley
- B. PTO Drive Belt
- C. Spring-loaded Idler Pulley
- D. Stationary Idler Pulley

TRANSMISSION DRIVE BELT REPLACEMENT



To avoid damaging belts, DO NOT PRY BELTS OVER PULLEYS.

1. Remove the deck drive belt. See *MOWER BELT REPLACEMENT AND ADJUSTMENT* sections.
2. Remove the grass screen that covers the transmission cooling fans.
3. Remove the clutch anchor bolts (A, Figure 28) that fasten the clutch anchor pad to the anchor.
4. Unplug the PTO clutch from the wire harness.
5. Remove the spring anchor nut (E) and remove the belt tension spring (D).

WARNING

STORED ENERGY DEVICE: Improper release of the belt tension spring can result in personal injury.

Use extreme caution when removing this spring.

6. Drop the belt (H) from the crankshaft pulley and around the PTO clutch.
7. From the front of the machine, pull the belt towards the front while sliding it up and over the transmission cooling fans.
8. Remove the old belt and replace with a new one. Make sure the V-side of the belt runs in the pulley grooves.
9. Install belt over the transmission cooling fans and on the transmission input pulleys (G), around the idler pulleys (F & I) and on the crankshaft pulley.
10. Reinstall the belt tension spring (D) onto the anchor bolt and reinstall the nylon nut (E).
11. Plug the PTO clutch into the wire harness.
12. Reinstall the clutch anchor pad and hardware (B & A). Tighten securely.
13. Reinstall grass screen and fasten securely.
14. Reinstall the deck drive belt. See *MOWER BELT REPLACEMENT AND ADJUSTMENT* sections.

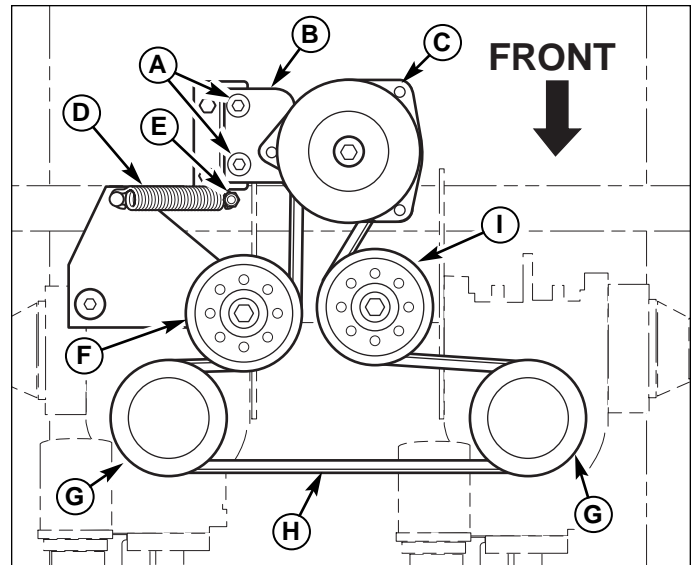

Figure 28. Transmission Drive Belt

- | | |
|------------------------------|-------------------------------|
| A. Anchor Hardware | F. Spring-loaded Idler Pulley |
| B. Clutch Anchor Pad | G. Transmission Input Pulley |
| C. PTO Clutch & Drive Pulley | H. Belt |
| D. Belt Tension Spring | I. Stationary Idler Pulley |
| E. Spring Anchor Nut | |

TRANSMISSION NEUTRAL & TRACKING ADJUSTMENTS

Neutral Adjustment

1. Park the machine on a smooth, level surface such as a concrete floor, away from bystanders and preferably facing a wall. Disengage the PTO, engage the parking brake, turn off the engine, and remove the ignition key.
2. Chock the front caster wheels. Raise the drive wheels off the ground and secure the machine with jack stands.
3. Start the engine and adjust throttle control to SLOW (lowest setting). See the *STARTING THE ENGINE* section for proper starting instructions.
4. Disengage the parking brake.
5. Using a 1/2" deep socket, SLOWLY turn the adjustment nut COUNTER-CLOCKWISE until the drive tire begins to rotate forward.
6. SLOWLY turn the adjustment nut CLOCKWISE until the drive tire begins to rotate backwards.
7. Set the adjustment half way in between where the forward and backwards rotations began.
8. Adjust the throttle control to FULL (highest setting). Cycle the speed control lever and neutral return pedal several times to insure and accurate adjustment has been made.

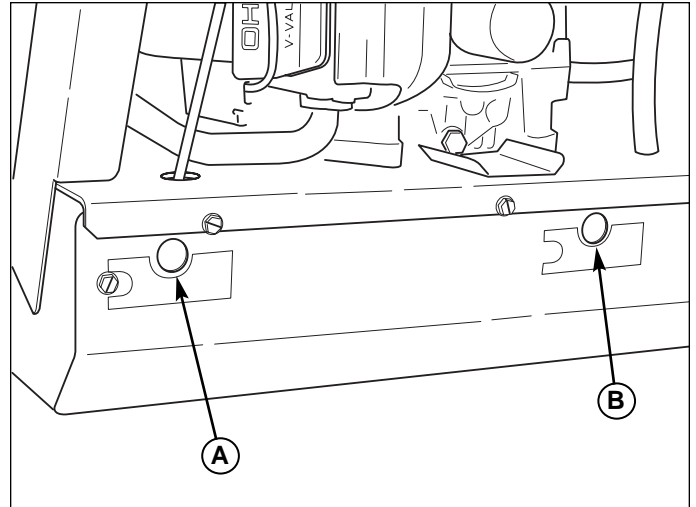

Figure 29. Neutral & Tracking Adjustment Points

- A. Left-Hand Adjustment
- B. Right-Hand Adjustment

Tracking Adjustment

Before making a tracking adjustment, be sure to check the following:

- Drive tires are inflated to 15 psi (103 kPa).
- Caster tires are inflated to 25 psi (172 kPa), are greased and turn freely.
- All controls are free from damage and operate freely.
- Machine is at full operating temperature.
- Make sure the machine is in neutral when the foot pedal is depressed. If not, adjust neutral as described above.

If Machine Veers to the LEFT:

1. Turn the LEFT adjustment nut 1/8 - 1/4 turn COUNTER-CLOCKWISE.
2. Turn the RIGHT adjustment nut 1/8 - 1/4 turn CLOCKWISE.
3. Drive machine on a flat, level surface to test and repeat steps 1 & 2 as necessary.

If Machine Veers to the RIGHT:

1. Turn the RIGHT adjustment nut 1/8 - 1/4 turn COUNTER-CLOCKWISE.
2. Turn the LEFT adjustment nut 1/8 - 1/4 turn CLOCKWISE.
3. Drive machine on a flat, level surface to test and repeat steps 1 & 2 as necessary.

TRANSMISSION MAINTENANCE AND SERVICE

The hydrostatic transmissions are sealed units that require no maintenance other than the following.

- Keep the grass screen and transmission cooling fins clear of grass, leaves and debris.
- Keep oil level in the reservoirs (A, Figure 30) at the "FULL" line (B, Figure 30). Extra oil in the reservoir will not benefit the machine.
- If it is necessary to add oil to the reservoirs, use SAE straight 20 or 30 weight motor oil. **DO NOT** use a multi-grade oils. Make sure the area around the oil reservoirs is free from dust, dirt and debris before opening the reservoirs.
- Make sure the oil reservoirs caps are tight.
- Keep water, dirt and debris from entering the oil reservoirs. A small amount of a contaminant could damage the transmissions.

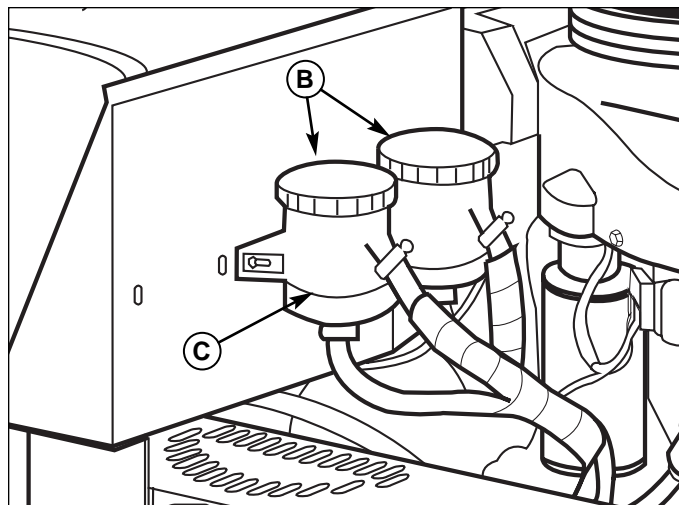

Figure 30. Oil Reservoirs

- A. Oil Reservoirs
- B. "FULL" Line

Changing Oil & Filters



Make sure transmissions and immediate surrounding areas are free from dirt and debris before changing the oil and filters. Cleanliness while performing this operation is extremely important.

1. Park the machine on a smooth, level surface such as a concrete floor. Disengage the PTO, engage the parking brake, turn off the engine, and remove the ignition key.
2. Place a drain pan under each transmission and remove the filters to drain the oil. See Figure 31.
3. Once oil has drained from transmissions, replace with new filters (P/N 21068-1), placing a light film on the seal of the filter before installing. Hand-tighten filter only.
4. Fill oil reservoirs 3/4 full with SAE straight 20 or 30 weight motor oil.

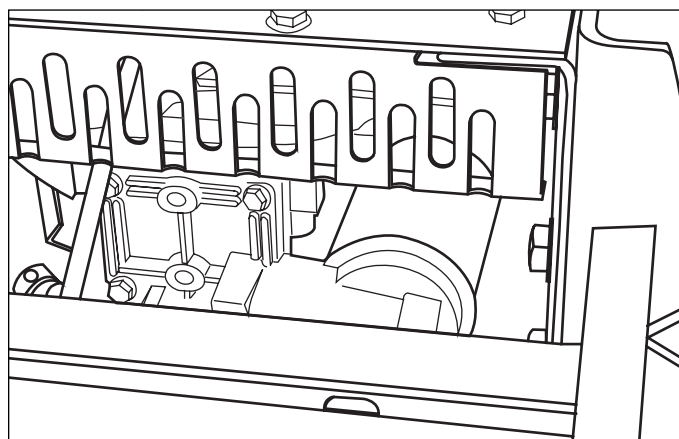

Figure 31. Transmission Oil Filter Location
(left-hand side shown)

To Bleed Air From Transmissions

1. Locate the machine in a secure area, away from bystanders and preferably facing a wall. Raise the drive tires off the ground and secure with jackstands.
2. Start the engine and adjust throttle control to FULL (highest setting). See the *STARTING THE ENGINE* section for proper starting instructions.
3. Run engine for 15 minutes. Watch the oil level in the reservoirs. Add oil to the "FULL" line (B, Figure 30) as necessary.
4. Watch oil levels for the next few days and add oil to the reservoirs as necessary.

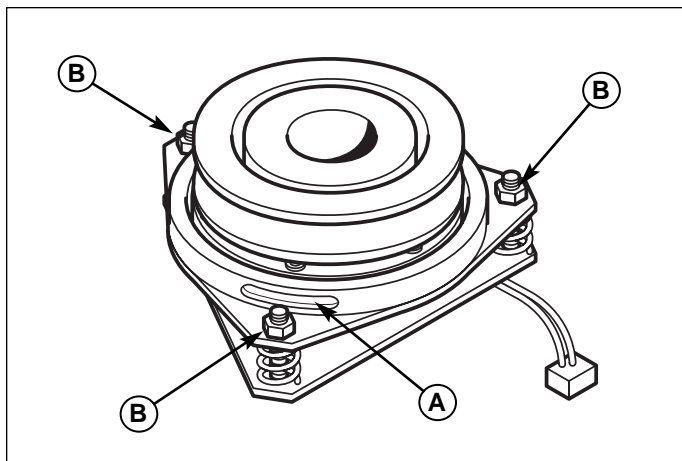

Figure 32. PTO Clutch Adjustment

- A. Adjustment Window (Qty. 3, one shown)
- B. Adjustment Nut

PTO CLUTCH ADJUSTMENT

Check the PTO clutch adjustment after the initial 50 hour break-in period and then after every 250 hours of operation. Also perform the following procedure if the clutch is slipping or will not engage, or if a new clutch has been installed.

1. Remove key from ignition switch and disconnect spark plug wires to prevent the possibility of accidental starting while the PTO is being adjusted.
2. See Figure 32. Note the position of the 3 adjustment windows (A) in the side of the brake plate and the nylock adjustment nuts (B).
3. Insert a .012"-.018" (0,30-0,45mm) feeler gauge (C) through each window, positioning the gauge between the rotor face and the armature face as shown in Figure 33.
4. Alternately tighten the adjustment nuts (B, Figure 32) until the rotor face and armature face just contacts the gauge.
5. Check the windows for an equal amount of tension when the gauge is inserted and removed, and make any necessary adjustments by tightening or loosening the adjustment nuts.

NOTE: The actual air gap between the rotor and armature may vary even after performing the adjustment procedure. This is due to dimensional variations on component parts, and is an acceptable condition.

6. Check the mower blade stopping time. The mower blades and mower drive belt should come to a complete stop within seven seconds after the electric PTO switch is turned off.

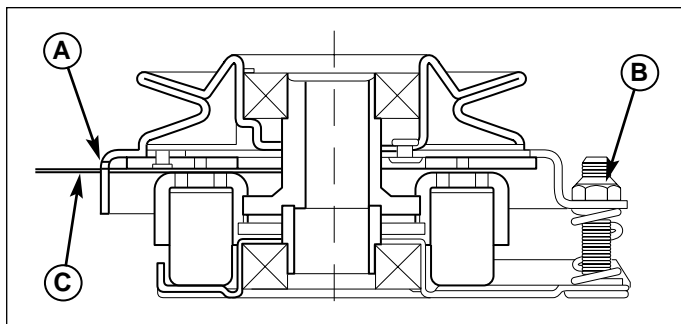

Figure 33. Adjust PTO Clutch

- A. Window
- B. Adjustment Nut
- C. .012"-.018" (0,30-0,45mm) Feeler Gauge

⚠ WARNING

To avoid serious injury, perform adjustments only with engine stopped, key removed and machine on level ground.

Blade Brake Check

Mower blades and mower drive belts should come to a complete stop within seven seconds after electric PTO switch is turned off.

1. Remove deck guard(s) for checking blade brake stop time ONLY. NEVER OPERATE the machine without guard(s) in place.
 1. With parking brake engaged and PTO disengage, start the engine engine.
 2. Observe the mower drive belt. Engage the PTO and wait several seconds. Disengage the PTO and check the amount of time it takes for the mower drive belt to stop.
 3. If the mower drive belt does not stop within seven seconds, perform the PTO Clutch Adjustment. If the belt still does not stop within seven seconds, see your dealer.

BATTERY SERVICE

WARNING

Keep open flames and sparks away from the battery; the gasses coming from it are highly explosive. Ventilate the battery well during charging.

Checking Battery Voltage

A voltmeter can be used to determine condition of battery. When engine is off, the voltmeter shows battery voltage, which should be 12 volts. When engine is running, the voltmeter shows voltage of charging circuit which normally is 13 to 14 volts.

A dead battery or one too weak to start the engine may not mean the battery needs to be replaced. For example, it may mean that the alternator is not charging the battery properly. If there is any doubt about the cause of the problem, see your dealer. If you need to replace the battery, follow the steps under Cleaning the Battery & Cables in the Regular Maintenance Section.

Charging a Completely Discharged Battery

1. Be aware of all the safety precautions you should observe during the charging operation. If you are unfamiliar with the use of a battery charger and hydrometer, have the battery serviced by your dealer.
2. Add distilled water sufficient to cover the plate (fill to the proper level near the end of the charge). If the battery is extremely cold, allow it to warm before adding water because the water level will rise as it warms. Also, an extremely cold battery will not accept a normal charge until it becomes warm.
3. Always unplug or turn the charger off before attaching or removing the clamp connections.
4. Carefully attach the clamps to the battery in proper polarity (usually red to [+] positive and black to [-] negative).
5. While charging, periodically measure the temperature of the electrolyte. If the temperature exceeds 125° F (51.6° C), or if violent gassing or spewing of electrolyte occurs, the charging rate must be reduced or temporarily halted to prevent battery damage.
6. Charge the battery until fully charged (until the specific gravity of the electrolyte is 1.250 or higher and the electrolyte temperature is at least 60° F). The best method of making certain a battery is fully charged, but not over charged, is to measure the specific gravity of a cell once per hour. The battery is fully charged when the cells are gassing freely at low charging rate and less than 0.003 change in specific gravity occurs over a three hour period.

Jump Starting With Auxiliary (Booster) Battery

Jump starting is not recommended. However, if it must be done, follow these directions. Both booster and discharged batteries should be treated carefully when using jumper cables. Follow the steps below EXACTLY, being careful not to cause sparks. Refer to Figure 34.

1. Both batteries must be of the same voltage.
2. Position the vehicle with the booster battery adjacent to the vehicle with the discharged battery so that booster cables can be connected easily to the batteries in both vehicles. Make certain vehicles do not touch each other.
3. Wear safety glasses and shield eyes and face from batteries at all times. Be sure vent caps are tight. Place damp cloth over vent caps on both batteries.
4. Connect positive (+) cable to positive post of discharged battery (wired to starter or solenoid).
5. Connect the other end of same cable to same post marked positive (+) on booster battery.
6. Connect the second cable negative (-) to other post of booster battery.
7. Make final connection on engine block of stalled vehicle away from battery. Do not lean over batteries.
8. Start the engine of the vehicle with the booster battery. Wait a few minutes, then attempt to start the engine of the vehicle with the discharged battery.
9. If the vehicle does not start after cranking for thirty seconds, STOP PROCEDURE. More than thirty seconds seldom starts the engine unless some mechanical adjustment is made.
10. After starting, allow the engine to return to idle speed. Remove the cable connection at the engine or frame. Then remove the other end of the same cable from the booster battery.
11. Remove the other cable by disconnecting at the discharged battery first and then disconnect the opposite end from the booster battery.
12. Discard the damp cloths that were placed over the battery vent caps.

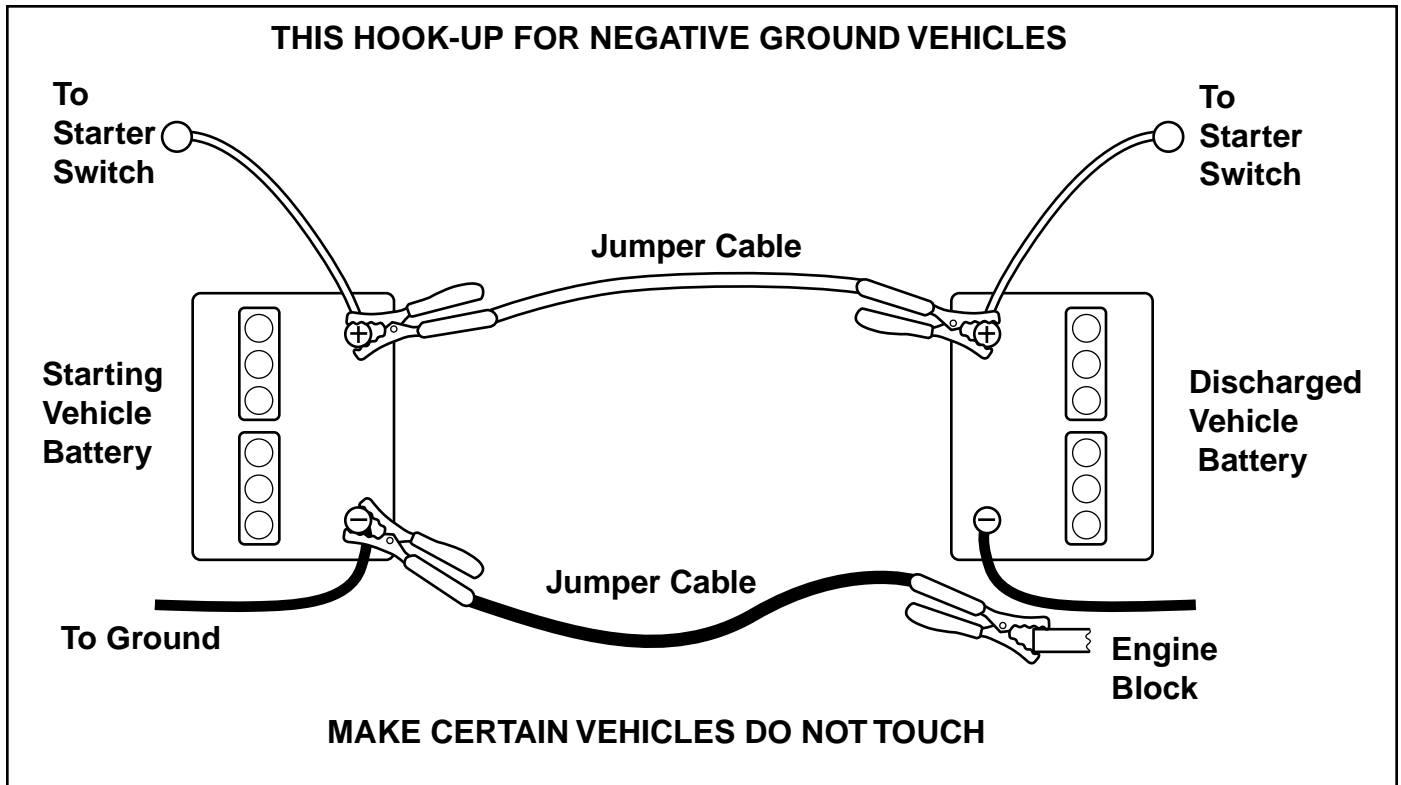

Figure 34. Jump Starting

⚠ WARNING

Any procedure other than the preceding could result in:

- (1) personal injury caused by electrolyte squirting out the battery vents,
- (2) personal injury or property damage due to battery explosion,
- (3) damage to the charging system of the booster vehicle or of the immobilized vehicle.

Do not attempt to jump start a vehicle having a frozen battery because the battery may rupture or explode. If a frozen battery is suspected, examine all fill vents on the battery. If ice can be seen or if the electrolyte fluid cannot be seen, do not attempt to start with jumper cables as long as the battery remains frozen.

⚠ WARNING

For your personal safety, use extreme care when jump starting. Never expose battery to open flame or electric spark – battery action generates hydrogen gas which is flammable and explosive. Do not allow battery acid to contact skin, eyes, fabrics, or painted surfaces. Batteries contain a sulfuric acid solution which can cause serious personal injury or property damage.

When removing or installing battery cables, disconnect the negative cable **FIRST** and reconnect it **LAST**. If not done in this order, the positive terminal can be shorted to the frame by a tool.

To avoid engine damage, do not disconnect battery while engine is running. Be sure terminal connections are tight before starting.

Common Replacement Parts & Accessories

COMMON REPLACEMENT PARTS

Listed below are parts numbers for the more common replacement parts. Use only genuine Ferris replacement parts to assure optimum performance and safety.

48" Deck Belt (PTO to Spindle).....	21723
48" Deck Belt (Spindle)	20873
48" Deck Blades (Set of 3)	20843S
52" Deck Belt (PTO to Spindle).....	21420
52" Deck Belt (Spindle)	21297
52" Deck Belt (DDSH Model)	22435
52" Deck Blades (Set of 3)	21227S
61" Deck Belt (PTO to Spindle).....	21510
61" Deck Belt (Spindle)	20824
61" Deck Belt (DDSH Model)	22061
61" Deck Blades (Set of 3)	20842S
Transmission Drive Belt	22173
Caster Tire (complete assembly)	21181S
Caster Tire Only	21181-1
Caster Tire Tube	21181-2
Caster Hub w/ Bearings	21181-3S
Bearing (for caster tires).....	21182
Bearing Retainer (for caster tires)	21043
Bushing (for caster arms).....	21541
Transmission Oil Filter	21068-1
Touch-Up Spray Paint (12 oz can)	22585
(Ferris Red)	
Ferris Red Grease (14.5 oz. Tube)	22285

ACCESSORIES

See your dealer to purchase any of the following accessories for your machine.

- 50" Snow Blower** (SB50) & **Hitch** (MHW)
- 60" Dozer Blade** (DB60) & **Hitch** (MHW)
- 48" Rotary Broom** (SWRB48) & **Hitch** (HDD)
- 60" Rotary Broom** (SWRB60) & **Hitch** (HDD)

Note: Information listed above is correct at time of printing, and are subject to changes in availability and specifications without notice. Part numbers may be superceded by other part numbers.



Lawn Care & Mowing Information

GENERAL INFORMATION

Proper mowing is an important part of maintaining your lawn in the best possible condition. A healthy and well maintained lawn is better able to resist drought, weeds, and other stresses. But too much maintenance is as detrimental to your lawn as neglect. Proper care for your lawn involves more than just “cutting the grass.” To have a healthy lawn, you need to know:

- Types of Grass, Climate and Conditions
- How and When to Water, Fertilize & Aerate
- How High to Mow the Grass
- When and How Often to Mow
- What Mowing Patterns to Use
- Proper Mowing Methods
- How to Solve Common Mowing Problems

TYPES OF GRASS, CLIMATE AND CONDITIONS

A variety of grasses are commonly grown in household lawns, but two main groups known as cool-season grasses (varieties of bluegrass, ryegrass, and fescue), and warm-season grasses (typically bermuda, buffalo grass, and zoysia varieties) are the most common.

The cool-season grasses are better suited to cooler climates, and do not endure hot and dry weather as well as warm-season grasses, but conversely, the warm-season grasses do not grow as well in cooler climates. Most residential lawns are typically seeded with a mixture of these grasses. (A local nursery or lawn center may help you to identify what kind of grass your lawn contains from a sample.)

Knowing your climate and conditions is also important to proper lawn care. Drier climates or conditions will require additional watering, while wetter climates may require more frequent mowing.

HOW AND WHEN TO WATER, FERTILIZE & AERATE

Every lawn's watering needs are unique and are dependent upon the type of grass and soil, the amount of local rainfall, and other conditions. **Most lawns are watered too often, but with too little water.** However too much water can allow development of diseases with your lawn. **It is best to water the lawn only when necessary, and then to water it slowly, evenly, and deeply—imitating a slow, soaking rain.**

WHEN TO WATER YOUR LAWN

When the lawn begins to wilt, the grass's color dulls, or footprints stay compressed for more than a few seconds, the lawn is beginning to dry out, and needs additional moisture. The best time to water is early morning to allow the water to soak deeply into the lawn and reduce the amount that evaporates in the hot afternoon sun.



HOW TO WATER YOUR LAWN

The best method of watering a lawn is to imitate a slow, soaking rain, applying about 1 inch of water. A method of verifying the amount that you have watered, is to place several empty tin cans (low shallow cans work best) in various spots around the lawn, and check the depth of water in the can during the watering process.

HOW TO FERTILIZE YOUR LAWN

Fertilizing with a slow-release fertilizer provides missing nutrients which help create slow, even growth. While opinions vary on the need for fertilizing, when and how much to fertilize will be more a factor of the condition of the lawn and soil than any routine. Remember that over-fertilizing can cause harm, and that most fertilizing should be applied in the spring so that it will release into the lawn through the summer. For more information, check with a local nursery or lawn care specialist, and read and follow the fertilizer manufacturer's instructions.

AERATING YOUR LAWN

Consider aerating your lawn in spring. Using an aerator to remove cores of soil from the lawn increases the speed of clipping decomposition and encourages deeper root growth by opening up the soil and permitting greater movement of water, fertilizer and air.

Lawn Care & Mowing Information

HOW HIGH TO MOW THE GRASS

Often cutting height is a matter of personal preference. Typically, you should mow the grass when it is between three and five inches high. The proper cutting height range for a specific lawn will depend upon several factors, including the type of grass, the amount of rainfall, the prevailing temperature, and the lawn's overall condition.

Cutting the grass too short causes weak, thin grass plants, which are easily damaged by dry periods and pests. Cutting too short is often more damaging than allowing the grass to be slightly higher.

Letting grass grow a bit longer—especially when it is hot and dry—reduces heat build-up, preserves needed moisture and protects the grass from heat damage and other problems. However, allowing grass to grow too high can cause thin turf and additional problems.

Cutting off too much at one time shocks the plant's growth system and weakens the grass plants. **A good rule of thumb is the 1/3 rule: to cut no more than one third of the grass height, and never more than 1 inch at a time.**

The amount of grass you are able to cut in one pass is also effected by the type of mowing system you are using (for example, broadcasting with side discharge decks can process a much larger volume of grass than mulching does).

NOTE: We cover some specific mowing instructions for mulching and broadcasting later in this Lawn Care section.

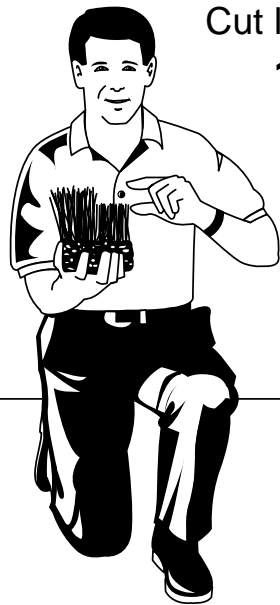

Cut less than
1/3

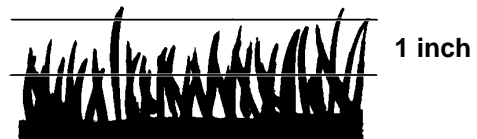
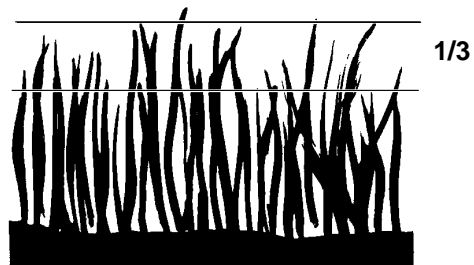
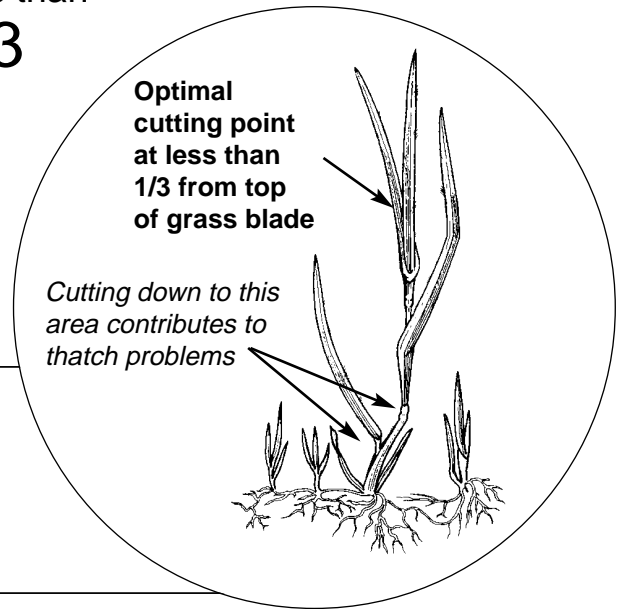

Proper Cutting Height

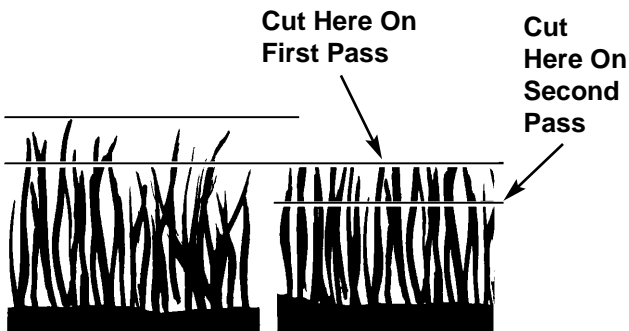

Tall Grass Requires Incremental Cutting

For extremely tall grass, set the cutting height at maximum for the first pass, and then reset it to the desired height and mow a second or third time.

Don't cover the grass surface with a heavy layer of clippings. Consider using a grass collection system and starting a compost pile.

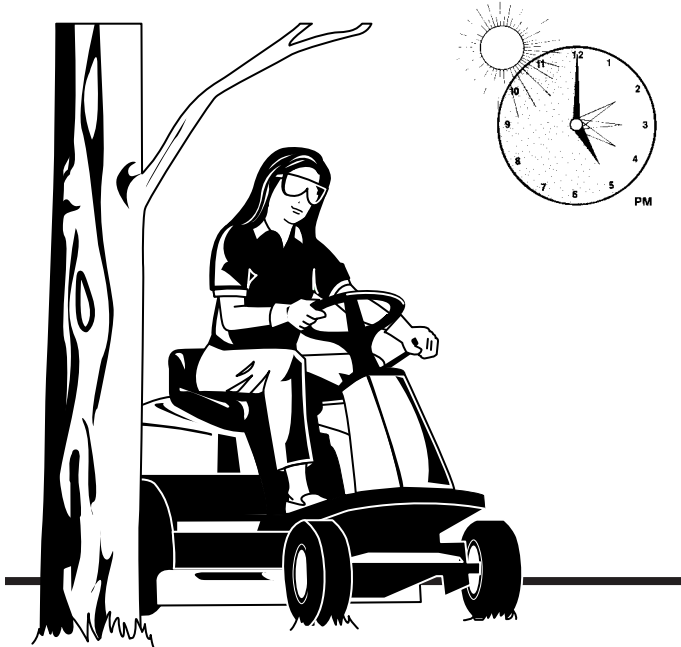

WHEN AND HOW OFTEN TO MOW

The time of day and condition of the grass greatly affect the results you'll get when mowing. For the best results, follow these guidelines:

- I Mow when the grass is between three and five inches high.
- I Mow with sharp blades. Short clippings of grass one inch or shorter decompose more quickly than longer blades. Sharp mower blades cut grass cleanly and efficiently, preventing frayed edges which harm the grass.
- I Mow at time of day when the grass is cool and dry. Late afternoon or early evening often provide these ideal mowing conditions.
- I Avoid mowing after rain or even heavy dew, and never mulch when the grass is wet (moist grass does not mulch well, and clumps beneath the mower deck).

WHAT MOWING PATTERNS TO USE

Always start mowing on a smooth, level area.

The size and type of area to be mowed will determine the best mowing pattern to use. Obstructions such as trees, fences and buildings, and conditions such as slopes and grades must also be considered.

- I Cut long straight strips overlapping slightly.
- I Where possible, change patterns occasionally to eliminate matting, graining or a corrugated appearance.
- I For a truly professional cut, mow across the lawn in one direction, then recut the lawn by mowing perpendicular to the previous cut.

Where possible, make one or two passes around the outside of the area discharging the grass INTO the lawn to keep the cut grass off fences and walks.

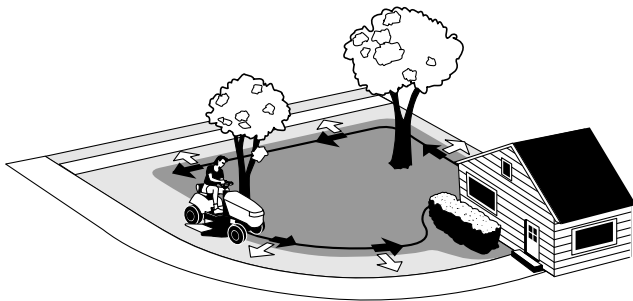
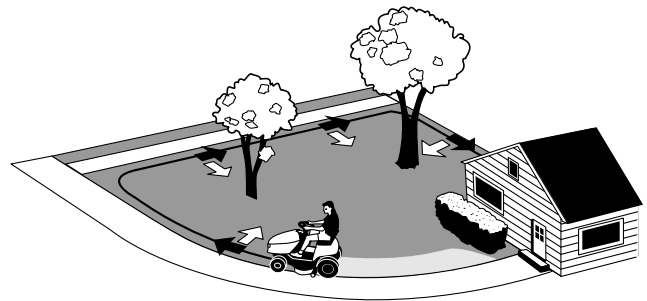

The remainder of the mowing should be done in the opposite direction so that the clippings are dispersed OUT onto the area of lawn previously cut.

Note: Always operate the engine at full throttle when mowing.

If you hear the engine slowing down, you are mowing too fast—using a slower ground speed will improve the cutting efficiency of the blades and prevents many common cutting problems. Use an appropriate ground speed for the thickness and height of the grass you are cutting (3rd gear or slower for manual gear models). If you hear the engine slowing down you are mowing too fast, use a slower ground speed.

Lawn Care & Mowing Information

MOWING METHODS

Proper Broadcast Mowing

Broadcasting, or side-discharging, disperses fine clippings evenly over the entire lawn. Many golf courses use this method. Your mower has a deep dish deck to allow freer circulation of clippings so they are broadcast evenly over the lawn.

ENGINE SPEED & GROUND SPEED FOR BROADCASTING

Always operate the engine at full throttle when mowing. If you hear the engine slowing down, you are mowing too fast—using a slower ground speed will improve the cutting efficiency of the blades and prevents many common cutting problems.

ALWAYS use an appropriate ground speed for the thickness and height of the grass you are cutting (3rd gear or slower for manual gear models). If you hear the engine



slowing down you are mowing too fast, use a slower ground speed.

HOW MUCH GRASS TO CUT OFF WHEN BROADCASTING

Mow when the grass is 3-5 inches long. Do not cut the grass shorter than 2 to 2-1/2 inches. Do not cut off more than 1 inch of grass in a single pass.

Proper Mulching

Mulching consists of a mower deck which cuts and recuts clippings into tiny particles and which then blows them down INTO the lawn. These tiny particles decompose rapidly into by-products your lawn can use.

UNDER PROPER CONDI-

TIONS, your mulching mower will virtually eliminate noticeable clippings on the lawn surface.

NOTE: When mulching under heavy cutting conditions, a rumbling sound may be present and is normal.

MULCHING REQUIRES EXCELLENT MOWING CONDITIONS

Mulching mowers cannot function properly if the grass is wet, or if the grass is simply high to cut. Even more than normal mowing, mulching requires that the grass be dry and the appropriate amount is cut.

Do not use the mower as a mulching mower during the first two or three mowings in the spring. The long grass blades, quick growth, and often wetter conditions are more suitable for broadcasting (side-discharging) or grass bagging operation.

ENGINE SPEED & GROUND SPEED FOR BROADCASTING

Use full engine throttle matched with a slow ground speed so that clippings will be finely cut. Ground speed while mulching should be HALF of the speed that would be used when broadcasting (side discharging) under similar conditions. Since mulching requires more horsepower than broadcasting, using a slower ground speed is vitally important for proper mulching operation.

Mulching Action

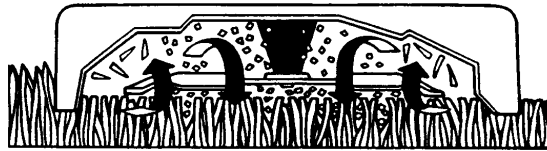

HOW MUCH GRASS TO MULCH

The best mulching action typically results from cutting only the top 1/2 inch to 3/4 inch of grass blade. This provides short clippings which decompose properly (much more quickly than longer clippings). The ideal cutting

height will vary with climate, time of year, and quality of your lawn. We recommend that you experiment with both the cutting height and ground speed until you achieve the best cut. Start with a high cutting height and using progressively lower settings until you find a cutting height that is matched to your mowing conditions and preferences.

TIPS On Dealing With Clippings

Clippings are **beneficial** to your lawn. A common misconception about clippings is that they automatically lead to thatch—this is untrue. Short clippings produced by broadcasting and clippings produced by mulching methods actually **contribute to a healthy lawn** because they:

- Reduce the evaporation of water from your lawn.
- Provide a cushioning layer to reduce lawn wear.
- Moderate soil temperature.
- Clippings act as a safe, non-polluting and inexpensive fertilizer that nourishes your lawn. Fresh cut grass blades are 85% water, and are a rich source of nitrogen which is essential to lush growth. And one garbage bag of clippings contains about 1/4 lb. of usable organic nitrogen.

COMPOSTING

The best way to recycle excess clippings and leave your lawn looking immaculate is to collect them with an efficient collection system and deposit them in a compost pile. A compost pile is a collection of grass, leaves, and other organic wastes which—when properly tended—decompose into an odorless, topsoil material. This material, in turn, acts as an inexpensive fertilizer for your lawn and garden.

How to start a healthy compost pile:

- 1 Build a bin using bricks, fencing, cement blocks, etc. or purchase a prefabricated bin from a garden store. The bin should also have venting on each side and from the bottom to the top.

- 2 Fill the bin with alternating layers of yard waste. Follow this recipe:

First layer: 3-4 inches of chopped brush or other coarse material.

Second layer: 6-8 inches of mixed leaves, grass clippings, sawdust, etc. Materials should be "sponge damp."

Third layer: 1 inch of soil to add micro-organisms that help break down organic matter.

Fourth layer: 1-2 inches of manure to provide the nitrogen needed by micro-organisms.

Keep adding layers until the bin is almost full. Top off with a 4-6 inch layer of straw and scoop out a "basin" to catch rain water.

- 3 Four or five days later the pile will reach temperatures of 140-160 degrees. At this time you'll notice it settling, a good sign your compost is working properly.
- 4 After 5-6 weeks, fork materials into a new pile, turning the outside of the old heap into the center of the new one. Add water if necessary. The compost should be ready to use within three to four months when dark brown, crumbly, and earthy-smelling.



Lawn Care & Mowing Information

SOLUTIONS FOR COMMON MOWING PROBLEMS

Streaking

Streaking is when thin strips of uncut grass are left behind the mower. Streaking is usually caused by operator error or poor blade maintenance.

Streaking

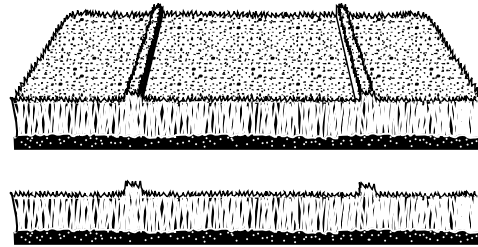

CAUSE

- Blades are not sharp
- Blades are worn down too far
- Engine speed is too slow
- Ground speed is too fast
- Deck is plugged with grass
- Not overlapping cutting rows enough
- Not overlapping enough when turning

SOLUTION

- Sharpen your blades
- Replace your blades
- Always mow at full throttle
- Slow down
- Clean out the mower
- Overlap your cutting rows
- When turning your effective cutting width decreases—overlap more when turning

Stepped Cutting

Stepped cutting is sharp ridges or uneven levels left in the lawn surface. Stepped cutting is usually caused by mower deck damage or misadjustment, or damage to mower blades.

Stepped Cutting

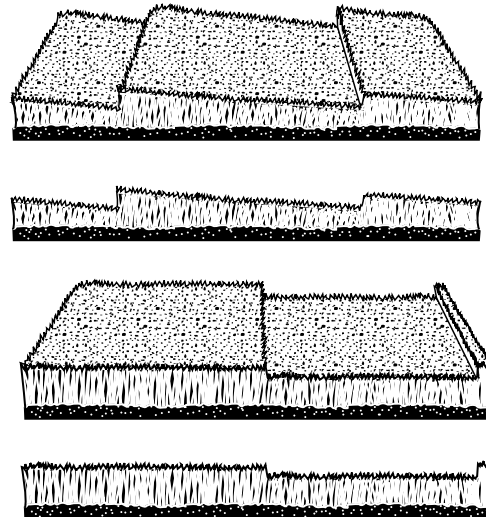

CAUSE

- Deck is not leveled correctly
- Tires are not properly inflated
- Blades are damaged
- Deck shell is damaged
- Mower spindle is bent or loose
- Blades are installed incorrectly

SOLUTION

- Level the deck correctly
- Check and inflate the tires
- Replace the blades
- Repair or replace the deck
- Repair or replace the spindle
- Reinstall the blades correctly

Lawn Care & Mowing Information

Uneven Cutting

Uneven cutting is waviness or smooth troughs in the lawn surface. Uneven cutting is usually caused by mower deck damage or misadjustment.

CAUSE

- Deck is not leveled correctly
- Blades are dull or worn
- Blades are damaged
- Deck is clogged with grass clippings
- Deck shell is damaged
- Mower spindle is bent or loose
- Blades are installed incorrectly

Uneven Cutting

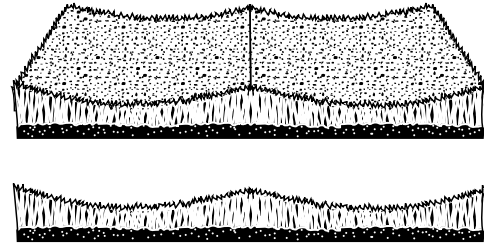

SOLUTION

- Level the deck correctly
- Sharpen or replace the blades
- Replace the blades
- Clean out the deck
- Repair or replace the deck
- Repair or replace the spindle
- Reinstall the blades correctly

Scalping

Scalping is when the mower deck comes close to or hits the ground. Scalping can be caused by the mower deck misadjustment, unevenness in the lawn, or by mower deck bouncing because the ground speed is too fast.

CAUSE

- Lawn is uneven or bumpy
- Mower deck cutting height is set too low
- Ground speed is too fast
- Deck is not leveled correctly
- Tire pressure is low or uneven

Scalping

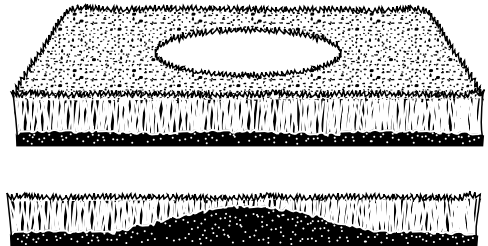

SOLUTION

- Roll or level the lawn
- Raise the cutting height
- Slow down
- Correctly level the deck
- Check and inflate the tires

Stingers

Stingers are sparse patches of uncut grass left behind the mower. Stingers are usually caused by operator error or poor blade maintenance.

CAUSE

- Blades are not sharp or are nicked
- Blades are worn down too far
- Engine speed is too slow
- Ground speed is too fast
- Deck is plugged with grass

Stingers

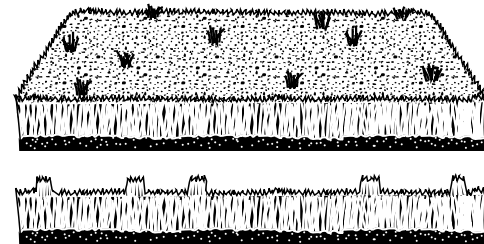

SOLUTION

- Sharpen your blades
- Replace your blades
- Always mow at full throttle
- Slow down
- Clean out the mower

Common International Symbols

 Choke

 Fast (Throttle)

 Slow (Throttle)

 Throttle

 Fuel

 PTO Clutch

 Parking Brake

 Brake

 Mower Cutting Height Adjustment

 Headlights

Technical Manuals

Additional Technical Literature Available



Operators Manuals

Additional copies of this manual are available, (and as part of our product support commitment, we maintain a stock of printed operators manuals going back many years!)

Parts Manuals

Fully illustrated parts manuals are also available — these manuals show all of the product's components in exploded views ("3D" illustrations which show the relationship of the parts and how they go together), as well as giving the replacement part numbers and quantities used. Important assembly notes and special torque values are included in these manuals.

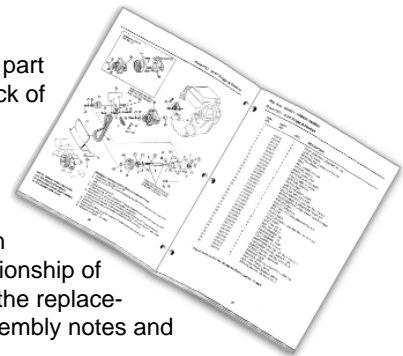

For the applicable manuals currently available for your model, contact your local dealer. Have the information listed in the box at the right available when making your request.

Model:	_____
Serial No.:	_____
Your Name:	_____
Address:	_____
City, State, Zip:	_____
Visa/Mastercard No.:	_____
Card Expiration Date:	_____

