

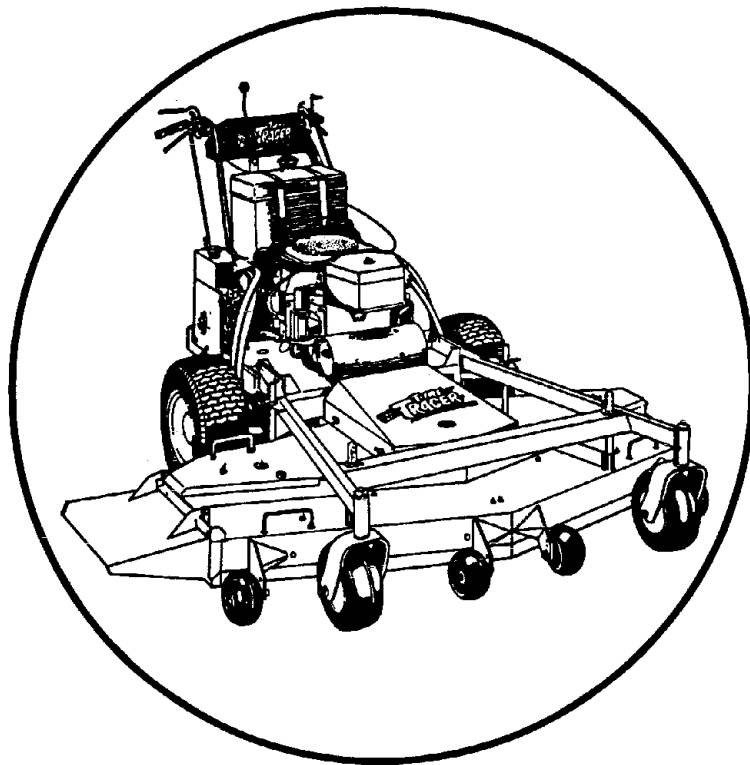

For Serial Nos.
130,000 & Higher

TURF TRACER HYDRO

Operator's Manual



Part No. 850437

WARNING

FAILURE TO FOLLOW CAUTIOUS
OPERATING PRACTICES CAN RESULT IN
SERIOUS OPERATOR INJURY.

CAUTION

1. Keep all shields, guards and safety devices (especially grass discharge system) in place and in proper working condition.
2. Stop engine and remove spark plug wire(s) or remove key before adjusting, servicing, or performing maintenance.
3. When mower deck becomes clogged, stop engine and remove spark plug wire(s) or remove key before cleaning blockage.
4. Keep hands, feet, and clothing away from power-driven parts.
5. Keep off mower unless seat or platform is provided.
6. Keep others off mower.

WARNING

The engine exhaust from this product contains chemicals known to the State of California to cause cancer, birth defects or other reproductive harm.

HEALTH WARNING

GASOLINE

Harmful or fatal if swallowed.
Long-term exposure to vapors has caused cancer in laboratory animals.

- Avoid prolonged breathing of vapors.
- Keep face away from nozzle and gas tank/container opening.
- Keep away from eyes and skin.
- Never siphon by mouth.

Failure to use caution may cause serious injury or illness.

Exmark reserves the right to make changes or add improvements to its products at any time without incurring any obligation to make such changes to products manufactured previously. Exmark, or its distributors and dealers, accept no responsibility for variations which may be evident in the actual specifications of its products and the statements and descriptions contained in this publication.

EXMARK PARTS PLUS® PROGRAM

EFFECTIVE DATE: September 1, 1995

Program

If your Exmark dealer does not have the Exmark part in stock, Exmark will get the parts to the dealer the next business day or the part will be FREE* Guaranteed!!

How the Program Works

1. If dealer does not have part in stock for a "down" unit at the time of request by customer, the dealer contacts his distributor by 1:00 p.m., local time, and requests Exmark Parts Plus® shipment of six (6) line items or less.
2. Distributor ships part(s) to dealer or customer, as requested by dealer, same day, overnight UPS. Distributor bills dealer for part and freight charges where applicable.
3. If distributor does not have the part(s) in stock to satisfy Exmark Parts Plus® order, he contacts Exmark by 3:00 p.m., central time, with an Exmark Parts Plus® order of six (6) line items or less.
4. If order is received by 3:00 p.m. central time, Exmark ships part(s) direct to dealer or customer, as requested by distributor, same day, overnight UPS. Exmark bills the distributor for parts and shipping charges, where applicable.
5. The customer pays for the part and freight if it is shipped under the Exmark Parts Plus® and if it arrive in accordance to the program.
6. Who pays for the part and freight if it fails to arrive overnight in accordance to the program?
 - A. Under any circumstance the customer does not pay.
 - B. If the part does not arrive overnight due to:
 1. The dealer not submitting the Exmark Parts Plus® order to his Exmark distributor by 1:00 p.m., the dealer pays for the part and freight.
 2. The Distributor being unable to ship the part the same day or not submitting the Exmark Parts Plus® order to Exmark by 3:00 p.m., central time, the Distributor pays for the part and freight.
 3. Exmark being unable to ship the part and the Exmark parts order is received by 3:00 p.m., central time, Exmark pays for the part and freight.
 4. If the part does not arrive overnight due to the shipper (UPS), the shipper pays for the freight and Exmark pays for the part.

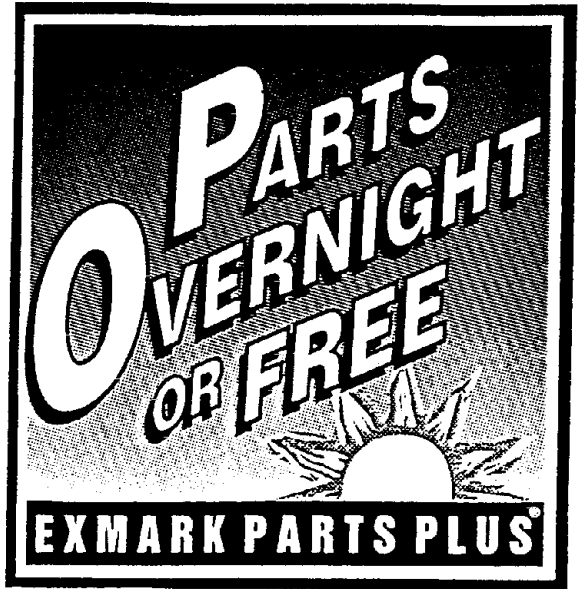

The following restrictions apply -- The Exmark Parts Plus® Program is available only through participating Exmark Dealers and applies only to orders submitted on this program Monday through Thursday. UPS has initiated a Saturday delivery program to many areas of the continental United States and can be requested for an overnight shipment on Friday to be delivered Saturday. The next day air charge, plus the Saturday delivery fee will be the responsibility of the purchaser. Exmark Mfg. will assume no responsibility for Saturday delivery shipments. To qualify, all Exmark Parts Plus® orders must be received by Exmark by 3:00 p.m., central time. Orders must be six (6) line items or less. Exclusions from the Exmark Parts Plus® Program are: Any wholegood or accessory in its entirety, engines and engine replacement parts, 5-speed Peerless transmissions and 5-speed transaxles, hydraulic or hydrostatic wheel motors, cutter decks and engine decks or any item exceeding United Parcel Service size and weight restrictions.

Due to UPS restrictions, aerosol spray paint is considered a hazardous material and cannot be shipped via UPS next day or Second Day Air.

Exmark Manufacturing stocks a limited supply of parts for transaxles, pumps and wheel motors. These parts can be ordered for Next Day Air shipment but will not be guaranteed per the Parts Plus Program.

CONGRATULATIONS on the purchase of your Exmark Mower. This product has been carefully designed and manufactured to give you a maximum amount of dependability and years of trouble-free operation.

OPERATOR'S MANUAL

This manual contains assembly, operating, maintenance, adjustment and safety instructions for your Exmark mower. **BEFORE OPERATING YOUR MOWER, CAREFULLY READ THIS MANUAL IN ITS ENTIRETY.** By following the operating, maintenance and safety instructions, you will prolong the life of your mower, maintain its maximum efficiency and promote safe operation.

If additional information is needed, or should you require trained mechanic service, contact your authorized Exmark equipment dealer or distributor.

All Exmark equipment dealers and distributors are kept informed of the latest methods of servicing and are equipped to provide prompt and efficient service in the field or at their service stations. They carry ample stock of service parts or can secure them promptly for you from the factory.

All Exmark parts are thoroughly tested and inspected before leaving the factory, however, attention is required on your part if you are to obtain the fullest measure of satisfaction and performance.

If you need to order replacement parts from your dealer, always give the model number and serial number of your mower as well as the quantity, part number and description of the part needed.

The serial number plate of the tractor is located on the top of the engine frame on the right hand side of the machine. The serial number plate for the mower deck is located on the front support pin gusset on the right hand side of deck. We suggest you record the numbers below for ready reference.

**PASTE LABEL FROM
LITERATURE PACKET HERE**

Tractor Model No. _____

OR

Tractor Serial No. _____

Deck Model No. _____

Deck Serial No. _____

Date Purchased _____

Purchased From _____

TABLE OF CONTENTS

1. SAFETY	PAGE
1.1 Safety Alert Symbol	1
1.2 Training	1
1.3 Preparation	1
1.4 Operation	2 - 3
1.5 Maintenance & Storage	4 - 5
1.6 Riding Attachments	5
1.7 Safety Signs	5 - 7
2. SPECIFICATIONS	
2.1 Model Number	8
2.2 Engine	8
2.3 Fuel System	8
2.4 Electrical System	8
2.5 Steering/Brake Control	8
2.6 Transmission	8
2.7 Wheel Drive System	8
2.8 Tires	9
2.9 Deck	9
2.10 Dimensions	9
2.11 Torque Requirements	10
3. ASSEMBLY INSTRUCTIONS	
3.1 to 3.10 Assembly	10 - 13
4. OPERATION INSTRUCTIONS	
4.1 Controls	14 - 15
4.2 Pre-Start	15 - 16
4.3 Operation Instructions	16 - 17
4.4 Transporting	17
5. MAINTENANCE & ADJUSTMENTS	
5.1 Periodic Maintenance	18 - 25
5.2 Adjustments	26 - 30
6. TROUBLE SHOOTING	
6.1 Mower Tacks Left or Right	31
6.2 Mower Cuts Unevenly	31
6.3 Engine Will Not Start	31 - 32
7. HYDRAULIC SCHEMATIC	33
8. WIRING DIAGRAMS	34
9. WARRANTY	35 - 36

1. SAFETY

1.1 SAFETY ALERT SYMBOL

THIS SAFETY ALERT SYMBOL  IS USED BOTH IN THIS MANUAL AND ON THE MACHINE TO IDENTIFY IMPORTANT SAFETY MESSAGES WHICH MUST BE FOLLOWED TO AVOID ACCIDENTS. THIS SYMBOL MEANS:

**ATTENTION! BECOME ALERT!
YOUR SAFETY IS INVOLVED!**

The safety alert symbol appears above information which alerts you of unsafe actions or situations and will be followed by the word DANGER, WARNING, or CAUTION.

When used with the word DANGER: IT DENOTES THAT AN EXTREME HAZARD EXISTS WHICH WOULD RESULT IN HIGH PROBABILITY OF DEATH OR IRREPARABLE INJURY IF PROPER PRECAUTIONS ARE NOT TAKEN.

When used with the word WARNING: IT DENOTES THAT A HAZARD EXISTS WHICH CAN RESULT IN INJURY OR DEATH IF PROPER PRECAUTIONS ARE NOT TAKEN.

When used with the word CAUTION: IT DENOTES A REMINDER OF SAFETY PRACTICES OR DIRECTS ATTENTION TO UNSAFE PRACTICES WHICH COULD RESULT IN PERSONAL INJURY IF PROPER PRECAUTIONS ARE NOT TAKEN.

1.2 TRAINING

- 1.2.1 Regard the Exmark mower as a piece of power equipment and teach this regard to all who operate this unit.
- 1.2.2 Read the instructions carefully. Familiarize yourself with the controls and the proper use of the equipment.
- 1.2.3 Never allow children, teenagers, or people unfamiliar with these instructions to use the mower.
- 1.2.4 Avoid mowing while people, especially children or pets, are nearby. Keep in mind that the operator or user is responsible for accidents or hazards occurring to other people or their property.

1.3 PREPARATION

- 1.3.1 The use of personal protective equipment, such as (but not limited to) protection for the eyes, ears, feet and head is recommended.
- 1.3.2 While mowing, always wear substantial footwear and long trousers. Do not operate equipment when barefoot or when wearing open sandals.
- 1.3.3 Thoroughly inspect the area where the equipment is to be used and remove all stones, sticks, wires, bones and other foreign objects which may damage the equipment or cause personal injury to the operator or bystanders.

 **WARNING**

- Fuel is *Highly Flammable*. *DO NOT* smoke while refueling. Refuel only in a well ventilated area, or refuel outdoors.
- Store fuel in containers specifically designed for this purpose.
- Add fuel before starting the engine. *Never* remove the cap of the fuel tank or add fuel when engine is running or when the engine is hot.
- If fuel is spilled, *DO NOT* attempt to start the engine. Move away from the area of the spill and avoid creating any source of ignition until fuel vapors have dissipated.

1.4 OPERATION

1.4.1 Give complete, undivided attention to the job at hand.

 **DANGER**

- *DO NOT* operate the engine in a small confined area where dangerous carbon monoxide fumes can collect.
- 1.4.2 Mow only in daylight or in good artificial light. *DO NOT* operate the mower when children or others are in the area.
- 1.4.3 When feasible, avoid operating the equipment in wet grass.
- 1.4.4 Use **EXTREME** caution when mowing and/or turning on slopes as loss of traction and/or control could occur. Mow **across** slopes with walk behind mowers, never up and down. Loss of control and/or loss of operator's footing could result in a fall with an arm or leg getting under the mower or engine deck and sustaining serious injury. Drive slower on slopes. *DO NOT* operate on slopes greater than 20 degrees. Watch for ditches, holes, rocks, dips, and rises which can cause erratic handlebar movement and loss of footing. Keep away from drop-offs and steep banks. Avoid sudden starts. Look down and behind you before and while moving backwards. *DO NOT* mow slopes when grass is wet - slippery conditions create hazardous footing, affect steering, and reduce traction and braking. The operator is responsible for safe operation on slopes.
- 1.4.5 Stop the blades when crossing surfaces other than grass; and when transporting the mower to and from the area to be mowed.
- 1.4.6 Never operate the mower with defective guards, shields, or covers. Always have safety shields, guards, switches, and other devices in place and in proper working condition.
- 1.4.7 *Do Not* change the engine governor settings or over speed the engine. Operating an engine at excessive speed may

increase the hazard of personal injury.

- 1.4.8 Place transmission in neutral, disengage blade drive before starting engine
- 1.4.9 Start the engine carefully with feet well away from the blades.
- 1.4.10 Keep hands, feet and clothing away from rotating parts while the mower is being operated.
- 1.4.11 Stop the engine and remove ignition key:
 - a) Before checking, cleaning or working on the mower.
 - b) After striking a foreign object (inspect the mower for damage and make repairs before restarting and operating the mower).
 - c) Before clearing blockages.
 - d) Whenever you leave the mower.
 - e) Before refueling.
 - f) Before making height adjustments.
- 1.4.12 Before stopping the engine, return the throttle control to the idle position for 30 seconds to allow the engine to cool down.
- 1.4.13 The fuel system is provided with a shut-off valve. The fuel shut-off valve is used to shut off the fuel when:
 - a) The machine will not be used for a few days.
 - b) During transport to and from the job.
 - c) When parking inside a building.
- 1.4.14 This mower was designed for one operator only. Keep all others away from mower during operation.
- 1.4.15 **Do Not** mow without the grass deflector or entire grass collection system in place and in proper working condition.

 **CAUTION**

- **Failure to follow safety instructions and cautious operating practices can result in serious injury.**

- 1.4.16 If jump starting is required:
 - a) connect the positive (+) power cable to the battery which will be used to jump the dead battery, then connect the other end of the cable to the positive (+) power terminal post on the dead battery (this post has the positive battery cable attached to it).
 - b) Connect the negative or ground cable (-) to the negative post on the battery which will be used to jump the dead battery, then connect the other end of the cable to any engine deck ground, preferably the engine block as far away from the battery as possible.
 - c) Disconnect battery cables in the reverse order after starting.

 **CAUTION**

- Although hazard control and accident prevention partially are dependent upon the design and configuration of the equipment, these factors are also dependent upon the awareness, concern, prudence and proper training of the personnel involved in the operation, transport, maintenance and storage of the equipment. It is essential that all Operator Safety Mechanisms be connected and in operating condition prior to use for mowing.

1.5 MAINTENANCE AND STORAGE

- 1.5.1 For engine maintenance, follow the engine manufacture's recommendations precisely as stated in the engine manual.
- 1.5.2 If carburetor adjustment is necessary, stand to one side and keep feet and hands clear while making adjustments.
- 1.5.3 Keep engine and engine area free from accumulation of grass, leaves, excessive grease or oil and other debris which can accumulate in these areas. These materials can become combustible and may result in a fire.
- 1.5.4 Store fuel in a container specifically designed for this purpose in a cool, dry place.
- 1.5.5 Keep the mower and fuel container in locked storage to prevent children from playing or tampering with them.
- 1.5.6 Gasoline powered equipment or fuel containers should not be stored in a basement or any enclosed area where open pilot lights or heat appliances are present.
- 1.5.7 Maximum mowing results and safety can only be achieved if the mower is properly maintained and operated correctly.
- 1.5.8. Check all bolts frequently to maintain proper tightness.
- 1.5.9. Keep all guards, shields and all safety devices in place and in safe working condition.
- 1.5.10 Frequently check for worn or deteriorating components that could create a hazard.
- 1.5.11 All replacement parts must be the same as or equivalent to the parts supplied as original equipment.

 **CAUTION**

- Make sure all hydraulic fluid hoses and lines are in good condition and all hydraulic connections and fittings are tight before applying pressure to hydraulic system.

! CAUTION

- Hydraulic fluid escaping under pressure may have sufficient force to penetrate skin and cause serious injury. If foreign fluid is injected into the skin, it must be surgically removed within a few hours by a doctor familiar with this type of injury or gangrene may result.

! CAUTION

- Keep body and hands away from pin holes or nozzles that eject hydraulic fluid under high pressure. Use paper or cardboard, *NOT HANDS* to search for leaks.

! CAUTION

- Safely relieve all pressure in the system before disconnecting lines or before performing any work the system.

1.6 RIDING ATTACHMENTS

Use only Exmark riding attachments. The use of other than Exmark riding attachments may create a hazardous condition resulting in injury.

1.7 SAFETY SIGNS

- 1.7.1 Keep all safety signs legible. Remove all grease, dirt and debris from safety signs.
- 1.7.2 Safety signs must be replaced if they are missing or illegible.
- 1.7.3 When new components are installed, be sure that current safety signs are affixed to the replaced components.
- 1.7.4 New safety signs may be obtained from your authorized Exmark equipment dealer or distributor or from Exmark Mfg. Co. Inc.
- 1.7.5 Safety signs may be affixed by peeling off the backing to expose the adhesive surface. Apply only to a clean, dry surface. Smooth to remove any air bubbles.
- 1.7.6 Familiarize yourself with the following safety signs and instruction labels. They are critical to the safe operation of your Exmark commercial mower.

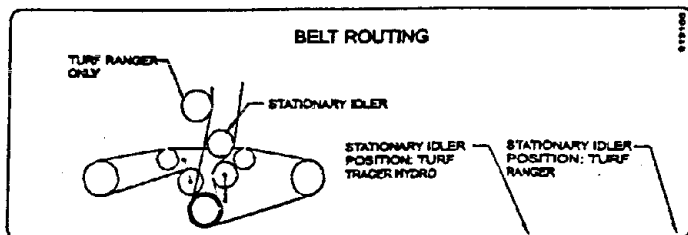

LOCATION: Top of Mower Deck
Beneath Center Shield

PART NO.
613100



LOCATION: LH and RH Front Top
Surface of Mower Deck

PART NO.
403005

⚠ DANGER

- USE EXTREME CAUTION WHEN OPERATING ON SLOPES
- MOW ACROSS SLOPE - NEVER UP AND DOWN
- DO NOT OPERATE ON SLOPES GREATER THAN 20°
- WATCH FOR DITCHES, HOLES, ROCKS, RIDGES, DIPS
- KEEP AWAY FROM DROP-OFFS AND STEEP BANKS
- LOOK BEHIND YOU BEFORE BACKING
- DRIVE SLOWER ON SLOPES
- EXECUTE TURNS SLOWLY
- DO NOT MOW VET SLOPES
- AVOID SUDDEN STARTS

323525

MAX 20°

- KEEP ALL PEOPLE OUT OF AREA WHEN MOWING
- THROWN DEBRIS OR BLADE CONTACT CAN CAUSE SERIOUS INJURY OR DEATH

- DO NOT OPERATE IN AN ENCLOSED AREA
- ENGINES PRODUCE CARBON MONOXIDE WHICH IS AN odorless DEADLY POISON

LOCATION:
Upper Handle Console

PART NO.
603350

⚠ CAUTION

1. READ OPERATOR'S MANUAL BEFORE OPERATING.
2. CLEAR AREA OF PEOPLE, PETS AND DEBRIS BEFORE MOWING.
3. KEEP RIDERS OFF.
4. BEFORE STARTING ENGINE:
 - A. BLADE CLUTCH MUST BE DISENGAGED.
 - B. TRANSMISSION MUST BE IN NEUTRAL.
 - C. FOR ELECTRIC START ENGINE, OPERATOR MUST BE IN OPERATING POSITION WITH OPERATOR PRESENCE CONTROL LEVERS DEPRESSED.
 - D. FOR MANUAL START ENGINE, PLACE LEFT AND RIGHT DRIVE LEVERS INTO NEUTRAL LOCK POSITION USING THUMB LATCHES.
5. BEFORE LEAVING OPERATOR'S POSITION:
 - A. SHIFT TRANSMISSION TO NEUTRAL
 - B. DISENGAGE BLADE CLUTCH
 - C. SHUT OFF ENGINE AND REMOVE KEY OR SPARK PLUG CABLE.
6. KEEP ALL SHIELDS AND GUARDS IN PLACE.
7. DO NOT OPERATE MOWER DECK UNLESS ENTIRE GRASS CATCHER IS IN PLACE.
8. USE CAUTION ON SLOPES.
9. DO NOT PARK ON SLOPES UNLESS WHEELS ARE CHOCKED OR BLOCKED.
10. SHUT OFF ENGINE AND REMOVE KEY AND/OR SPARK PLUG CABLE BEFORE MAKING ADJUSTMENTS, SERVICING OR CLEANING.

LOCATION: Front Right Corner
of Engine Deck

PART NO.
303508

⚠ WARNING

DO NOT OPERATE WITHOUT DISCHARGE DEFLECTOR OR ENTIRE GRASS COLLECTION SYSTEM IN PLACE. DO NOT REMOVE GRASS CATCHER UNTIL BLADES HAVE STOPPED.

LOCATION: On Top Rear RH-Surface
of Mower Deck

PART NO.
303517

⚠ WARNING

**OPEN BELT DRIVE!
STOP ENGINE BEFORE
REACHING UNDERNEATH**

LOCATION:
LH Side of Rear Surface
of Engine Deck

⚠ WARNING

**ANTI-SCALP ROLLER
ADJUSTMENT**

FOR MAXIMUM DECK FLOTATION,
PLACE ROLLERS IN POSITIONS SHOWN.

CUTTING HEIGHT	INCHES (mm)
1.5	(38)
2.0	(51)
2.5	(64)
3.0	(76)

ROLLERS SHOULD MAINTAIN 1/4" (6.4) CLEARANCE TO GROUND. DO NOT ADJUST ROLLERS TO SUPPORT MOWER DECK.

CUTTING HEIGHT ADJUSTMENT

DECK SUPPORT PIN	INCHES (mm)	CUTTING HEIGHT
C1	1.5 (38)	CUTTING HEIGHT
C2	2.0 (51)	
C3	2.5 (64)	
C4	3.0 (76)	
C5	3.5 (90)	
C6	4.0 (102)	
C7	4.5 (114)	

PART NO.
543660

LOCATION: LH Front of Mower
Deck Top Surface



LOCATION:

On Top Front, Left Hand Surface of Engine Deck Next to Muffler Shield

PART NO. 303293



PART NO. 513746

LOCATION: On Top of Fuel Tank

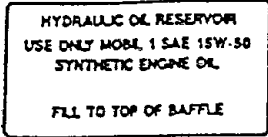

PART NO. 513890

PART NO. 404143

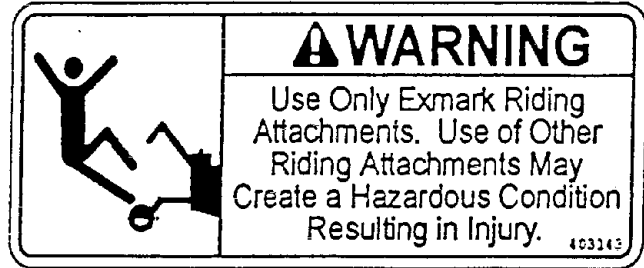

LOCATION:

On Top of Hydraulic Tank

LOCATION: Rear Surface of Engine Deck

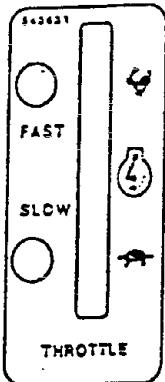

PART NO. 543631

LOCATION:

Upper Handle Console



PART NO. 303102

LOCATION: Upper Handles

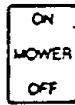

PART NO. 543626

LOCATION: Upper Handle Console

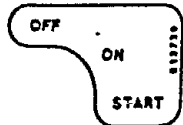

PART NO. 513739

LOCATION: Upper Handle

LOCATION: Upper Handle Console

Part No. 613169

6
5
4
3
2
1
N



PART NO. 603845

Part No. 413214



LOCATION:

Left Rear Corner of Engine Deck

LOCATION: Right Side of Hydro Control Crank Arm

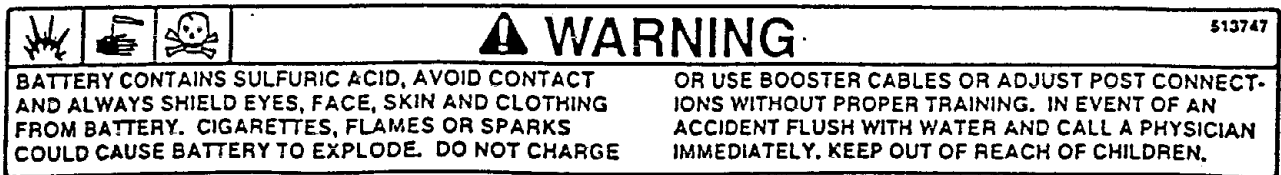

PART NO. 513747 LOCATION: Battery Cover

2. SPECIFICATIONS

2.1 MODEL NUMBER: TT18KC AND TT22KC

2.2 ENGINE

- 2.2.1 Engine Specifications:
See your Engine Owner's Manual.
- 2.2.2 3600 RPM (No Load).

2.3 FUEL SYSTEM

- 2.3.1 Capacity: 5.0 gal. (18.9 L.)
- 2.3.2 Type of Fuel: Regular **unleaded** gasoline, 87 octane or higher. In countries using the research method, it should be a 90 octane *minimum*.
- 2.3.3 Fuel Filter: Replaceable in-line
- 2.3.4 Fuel Shut-Off Valve: 1/4 turn

2.4 ELECTRICAL SYSTEM:

- 2.4.1 Charging System: Flywheel Alternator
- 2.4.2 Charging Capacity: 15 amp
- 2.4.3 Battery Type: BCI Group U1 235 amps at 0° F
- 2.4.4 Battery Voltage: 12 Volt; Polarity, negative ground.
- 2.4.5 Fuses: blade type, 20 amp to charging circuit; 20 amp to electric clutch.
- 2.4.6 Safety Interlock System: Operator must have OPC (Operator Presence Control) levers held in contact with handle grips, transmission in neutral and blade clutch disengaged to start engine. Release of OPC levers will cause the engine to stop if *hydro transmission is not in neutral and/or blade clutch is engaged*.

2.5 STEERING/BRAKE CONTROL:

Fingertip drive control levers provide independent speed control, braking and neutral to each drive wheel for moving forward or reverse, stopping and power turning.

2.6 TRANSMISSION:

Twin Hydrostatic Drive

- 2.6.1 Two Hydro Gear (Sundstrand) BDP-10L series variable displacement pumps independently coupled to two high efficiency Ross wheel drive motors.
- 2.6.2 Speed Range: Forward 0 - 6.2 mph (10.0 km/h)
Reverse 0 - 2.2 mph (3.5 km/h)

2.7 WHEEL DRIVE SYSTEM:

Drive wheels are direct coupled to Ross wheel drive motors with 1.0" (25.4 mm) tapered shaft.

2.8 Tires

	<u>Drive</u>	<u>Front Caster</u>
Size	16 x 7.50-8	9 x 3.50-4
Quantity	2	2
Tread	Turfsaver	Smooth
Ply Rating	4	4
Pressure ..	14 psi (97 kPa)	22 psi (152 kPa)

2.9 DECK

- 2.9.1 Model Numbers: FMD603 and FMD523
- 2.9.2 Cutting Width: 60 in. (152.4 cm.)
52 in. (132.1 cm.)
- 2.9.3 Discharge: Right Side
- 2.9.4 Optional Mulch Kit and Bagger available.
- 2.9.5 Blade Size: 60" - (3 ea.) 20.50 in. (52.1 cm.)
52" - (3 ea.) 18.00 in. (45.7 cm.)
- 2.9.6 Type of Drive: Electric clutch mounted on engine shaft.
Blades driven by two belts with self tensioning idlers.
- 2.9.7 Adjustable anti-scalp rollers (6 ea.)
- 2.9.8 Cutting Height: Adjusts in 1/2" (1.3 cm) increments
from 1 1/2" (3.8 cm) to 4 1/2" (11.5 cm).
- 2.9.9 Deck Mounting: Full floating deck is attached to
out-front support frame, removable for service.

2.10 DIMENSIONS

2.10.1 Overall Width:

	w/52" Deck	w/60" Deck
Discharge chute down	62.7" (159.3 cm)	70.5" (179.1 cm)
Discharge chute up (Transport only)	53.0" (134.6 cm)	60.9" (154.6 cm)

2.10.2 Overall Length:

	w/52" Deck	w/60" Deck
Overall Length	78.75" (200.0 cm)	79.25" (201.3 cm)

2.10.3 Curb Weight:

	w/52" Deck	w/60" Deck
Total weight*	648 lbs. (294 kg)	678 lbs. (307 kg)

* Weights will vary slightly depending on engine option.

2.10.4 Overall Height: 43.5" (110.5)

2.10.5 Tread Width (to outside of tires): 37.5" (95.3 cm)

2.11 TORQUE REQUIREMENTS

<u>BOLT LOCATION</u>	<u>TORQUE</u>
Cutter Housing Spindle Nut	75-80 ft/lbs.
Blade Mounting Bolt	75-80 ft/lbs.
Mower Deck Support/Engine Deck Mount	30-35 ft/lbs.
Anti-Scalp Roller Bolts	40-45 ft/lbs.
Engine Mounting Bolts.....	15-20 ft/lbs.
Wheel Lug Nuts	90-95 ft/lbs.

3. ASSEMBLY INSTRUCTIONS

3.1 UNCRATE UNIT

3.1.1 Remove tractor and cutter deck from crate.

3.2 INSTALL DRIVE WHEELS.

3.2.1 Remove four wheel lug nuts from each wheel hub.

3.2.2 Raise the front of the engine deck. Install the drive wheels with the valve stem facing the outside of the machine. Reinstall lug nuts and torque to 90-95 ft/lbs.

3.2.3 Check air pressure in drive tires; recommended pressure is 12-16 psi. Measure circumference of each drive tire. Adjust tire pressure within 12-16 psi range to try to make tire circumferences match as closely as possible.

3.3 CUTTER DECK INSTALLATION

3.3.1 Release the wheel drive system by opening the drive wheel release valves (See 4.1.11). Roll the tractor to the cutter deck assembly and allow the tractor assembly to tip backward until the rear of the engine deck contacts the ground.

3.3.2 Remove cutter deck support frame from cutter deck by removing the two large hairpins and washers from the front deck support pins and by removing the two small hairpins and washers from the rear deck support pins (See Figure 2).

! CAUTION

- Securely hold down the front end of the unit when the cutter deck is not installed. The tractor or tractor with mounted cutter support frame may cause the front of the unit to rise suddenly, causing unexpected injury.
- This may also happen when the cutter deck and support frame, while connected to the tractor, have the two front support rod hairpins removed.

3.3.3 Install cutter deck support frame to tractor engine deck and secure using (8) 3/8-16 x 1" screws, (8) disc spring washers and (8) whizlock nuts from bolt bag (See Figure 1).

NOTE: Make sure that the bolts are placed in the proper mounting holes in both frames. There are different mounting bolt locations for the 60" and 52" decks (See Figure 1).

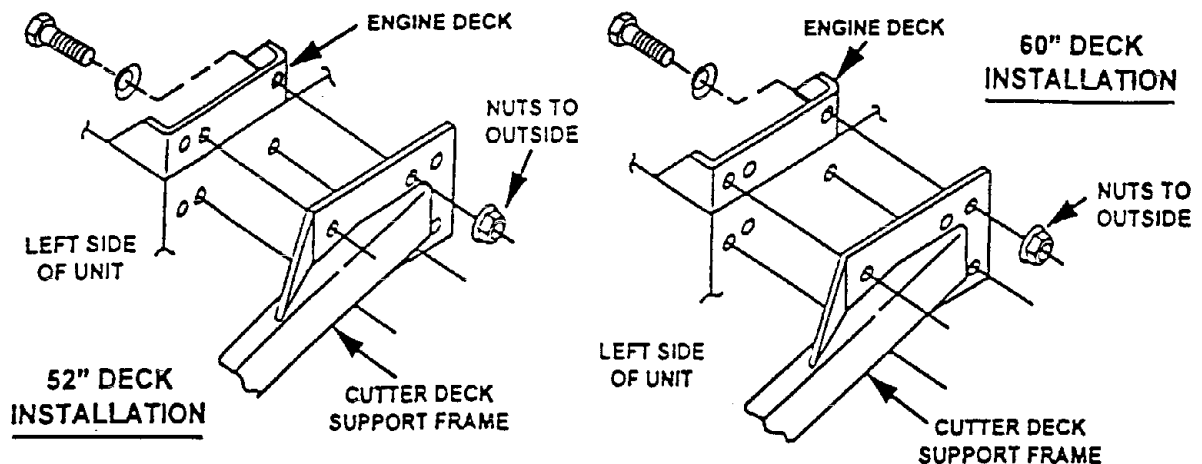

FIG. 1
DECK SUPPORT INSTALLATION

NOTE: Place spring washer cone side against bolt head (cupped side away from head) and install to inside of engine deck (as shown in Figure 1). Install with whizlock nuts to the outside of the support frame. Tighten until spring washers are flat.

3.3.4 Position tractor with cutter deck support frame in place, over the cutter deck.

! CAUTION

- Securely hold down the front end of the unit when the cutter deck is not installed. The tractor or tractor with mounted cutter support frame may cause the front of the unit to rise suddenly, causing unexpected injury.
- This may also happen when the cutter deck and support frame, while connected to the tractor, have the two front support rod hairpins removed.

Align and re-install the cutter deck support pins into the support frame. Install the two large washers and hairpins onto the front support pins and the two smaller hairpins and washers onto the rear support pins (See Figure 2).

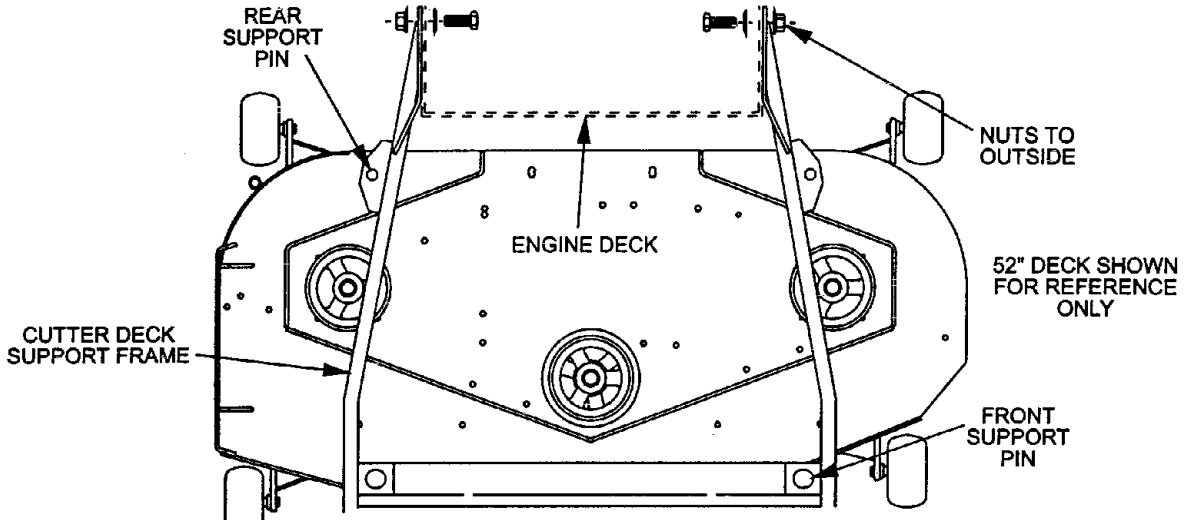

FIG. 2
SUPPORT PIN LOCATION

3.3.5 Cutter Deck Stationary Idler Installation:

Locate the two holes along the back center section of the deck (See Figure 3) and install the stationary idler and related parts (from bolt bag) in the right hand hole. Be sure the coned end of the disc spring washer is against the head of the bolt. Tighten hardware.

3.3.6 Install the deck drive belt around the clutch. Refer to belt routing decal. Be sure belt is in the clutch drive sheave groove. Place the other end of the belt into the V-groove of the stationary idler, move the spring loaded idler outward and route the belt around the inside of the spring loaded idler. Position the belt into the V-groove of the cutter deck drive sheave. **Carefully** release the spring loaded idler. Install the center belt shield.

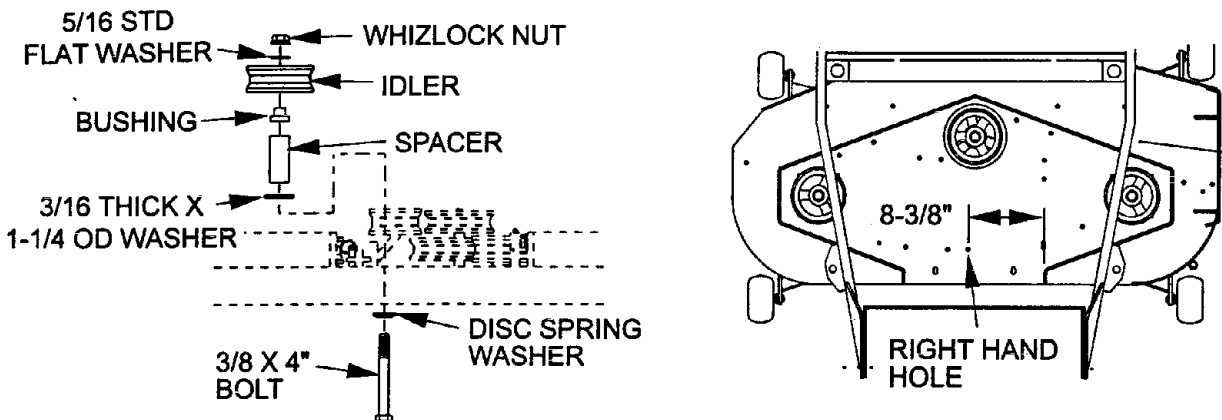

FIG. 3
STATIONARY IDLER INSTALLATION

3.3.7 Adjust cutting height of deck and anti-scalp rollers (See Adjustment Section 5.2.1.

3.4 SERVICE ENGINE: See Engine Operator's Manual.

3.5 SERVICE BATTERY: Machine is shipped with battery dry.

- 3.5.1 Remove battery cover from machine. Disconnect the battery cables (negative (black) cable first) and remove battery.

 **DANGER**

- Be sure ignition switch is "OFF" and key is removed before disconnecting or installing the battery. Keep sparks and flame away from battery at all times.

3.5.2 Place battery on a level surface and remove vent caps.

3.5.3 Fill cells with battery grade sulfuric acid (1.625 specific gravity). Fill until halfway between top of separators and bottom of vent well.

3.5.4 Check acid temperature and state of charge:

- a) Put battery thermometer in center cell.

Acid temperature must be at least 80° F (26.7° C)

- b) Check state of charge with an electrical battery tester, or a battery hydrometer.

If using an electrical battery tester, charge must be "Good".

If using an hydrometer the specific gravity must be at least 1.250.

3.5.5 If acid temperature is not 80° F (26.7° C) or state of charge is not "Good", charge at 15 amps (20 amp max). Slow charging is permissible. Acid temperature must never exceed 125° F (51.7° C) while charging.

3.5.6 After charging, add battery acid until it reaches the bottom of the vent wells and install vent caps. Prior to installing the battery back onto the unit, check battery with a hi-rate load tester (follow the printed instructions on the tester). "State of Charge" and "Condition" must be indicated as "Good" or "OK".

3.5.7 Install battery in machine. Connect cables to terminal posts, positive (red) cable first, then negative (black) cable. Reinstall battery cover.

3.7 GREASE UNIT:

NOTE: UNIT IS NOT GREASED AT THE FACTORY.

Refer to Maintenance Section 5.1.14 for grease zerk locations and grease amounts.

3.8 FAMILIARIZE YOURSELF WITH THE CONTROLS.

See Controls Section 4.1.

3.9 FOLLOW PRE-START INSTRUCTIONS.

See Pre-Start Section 4.2.

3.10 PERFORM NECESSARY ADJUSTMENTS.

See Maintenance and Adjustment Section 5.

4. OPERATION INSTRUCTIONS

4.1 Controls

4.1.1 Drive Levers: Located on each side of the upper handle assembly directly below the handle grips (See Figure 4). These levers individually control the speed and direction of each drive wheel. When the speed control lever is moved out of the neutral position and the lock latches are moved into the drive position, as shown in Figure 4, and the drive levers are released, the drive wheels are engaged in the forward direction.

Squeezing the left hand and/or right hand lever causes the left hand and/or right hand drive wheel respectively to slow down, stop, or reverse, depending on how far each drive lever is "squeezed". Squeezing the drive levers beyond the neutral position causes the drive wheels to engage in the reverse direction regardless of the position of the neutral lock levers and the speed control lever.

4.1.2 Neutral Lock Latch: Located directly above the drive levers. These latches allow the operator to lock the drive levers in a "neutral" position where neither of the drive wheels are engaged in either a forward or reverse direction. See Figure 4.

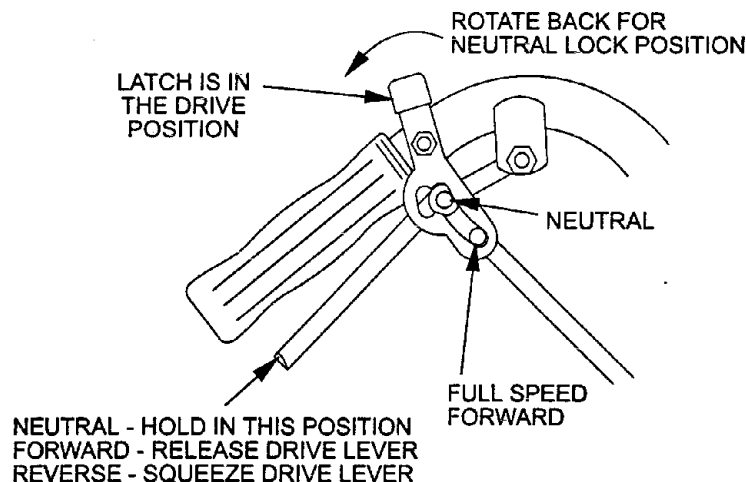

FIG. 4
DRIVE LEVER, NEUTRAL LOCK LATCH
OPERATION

4.1.3 Operator Presence Control (OPC) Levers: Located on the upper handle assembly directly above the handle grips. *When these levers are depressed, the OPC system senses that the operator is in the normal operator's position. When the levers are released, the OPC system senses that the operator has moved from the normal operating position and will kill the engine if either the speed control lever is not in the neutral position or the blade clutch is engaged.*

4.1.4 Electric Blade Clutch Engagement: Switch is located on left side of control console. Moving the toggle switch ahead

will engage the blade clutch and moving it to the rear will disengage the blade clutch. Switch lever must be pulled out to be moved to the "ON" position. Operator must have operator presence control levers depressed when blades are engaged or engine will stop.

- 4.1.5 Choke Control: Located on the control console right side. Choke is used to aid in starting a cold engine. The "Off" position is pushed in and the "On" position pulled out. Do not run a warm engine with choke in the "On" position.
- 4.1.6 Throttle Control: Located on the control console's right side next to the choke control. The throttle is used to control engine speed. Moving the throttle control forward will increase engine speed and moving it to the rear will decrease engine speed.
- 4.1.7 Speed Control Lever: Located in middle of control console, it controls the maximum forward speed and is infinitely variable from neutral (0 mph) to 6.2 mph.
- 4.1.8 Ignition Switch: Located on the control console just below the choke control. The ignition switch has three positions, "Off", "On" and "Start". Insert key into switch and rotate clockwise to the "On" position. Rotate clockwise to the next position to engage the starter (key must be held against spring pressure in this position). Operator must have *speed control lever in neutral, OPC levers depressed* and *blade clutch disengaged* to start engine. When engine starts, release key.
- 4.1.9 Hour Meter: Located on the left hand side of console just above the blade clutch switch. The hour meter records the number of hours that the engine has run. If ignition switch is left on without engine running, hour meter will not run.
- 4.1.10 Fuel Shut-Off Valve: Located along the fuel line. The fuel shut-off valve is used to shut off the flow of fuel when parking inside a building, during transportation to and from the job sites, and when the machine will not be used for a few days.
Rotate valve 1/4 turn clockwise to shut fuel off. Rotate valve 1/4 turn counter-clockwise to turn fuel on.
- 4.1.11 Drive Wheel Release Valves: Located on the top corner of the hydrostatic pumps. Drive wheel release valves are used to release the hydro-static drive system to allow the machine to be moved by hand without the engine running. Turn valves one-half turn counterclockwise to release the drive system. Turn clockwise to reset the drive system.
Do Not over tighten.

4.2 Pre-Start

- 4.2.1 Fill fuel tank. For best results use only clean fresh regular grade **unleaded** gasoline with an octane rating of 87 or higher. Regular grade leaded gasoline may also be used; however, combustion chamber and cylinder head will require more frequent service. See Engine Owner's Manual.
Do not add oil to gasoline.

Do not overfill fuel tank. Leave room for fuel to expand.

- 4.2.2 Refer to Maintenance and Adjustment Section 5 and perform all of the necessary inspection and maintenance steps.
- 4.2.3 Familiarize yourself with controls and operation of unit. See Controls Section 4.1 and Operating Instructions Section 4.3.

4.3 OPERATING INSTRUCTIONS

- 4.3.1 Starting Engine: Open fuel valve.

Operator must have *Operator Presence Control (OPC) levers depressed*, the *blade clutch disengaged* and *speed control lever in neutral*.

On a cold engine, place the throttle midway between the "Slow" and "Fast" positions and place the choke in the "On" position. On a warm engine, place the throttle lever midway between "Slow" and "Fast" positions and leave the choke in the "Off" position.

Turn ignition switch to "Start" position. Release the switch as soon as the engine starts.

On a cold engine, gradually return choke to the "Off" position after engine starts and warms up.

IMPORTANT: Do not crank the engine continuously for more than ten (10) seconds at a time. If the engine does not start, allow a 60 second starter cool-down period between starting attempts. Failure to follow these guidelines can burn out the starter motor.

NOTE: It is helpful to have the left and right neutral lock latches applied when starting the engine, See Controls Section 4.1.2.

- 4.3.2 Stopping Engine: Disengage blade clutch, move speed control lever to neutral and lock drive levers in neutral. Move throttle to the "Slow" position. Allow engine to idle for 30 seconds to allow cool down. Rotate ignition switch to "Off" position. Remove key to prevent children or other unauthorized persons from starting engine.
- 4.3.3 Drive Lever/Neutral Lock Latch Operation: To lock the drive levers in neutral, squeeze the drive levers back to the neutral position (*Do Not squeeze the drive levers all the way back as this will cause the drive wheels to go into full reverse direction*). Place thumbs on the upper portion of the neutral lock latches and move them to the rear. Release drive levers (See Figure 4).

CAUTION

- Be sure the pins protruding through the slots of each neutral lock latch are completely engaged in the rear slot of each latch, if not, the drive levers could unexpectedly slip into the forward drive position.

To place the drive levers in the drive position, firmly hold the drive levers, place thumbs on the upper portion of the

neutral lock latches and move them forward to release the drive levers. Slowly and smoothly release the drive levers.

- 4.3.4 Drive Wheel Engagement/Turning: With drive levers located in neutral, shift speed control lever to desired forward speed. Slowly squeeze and hold both drive levers in the neutral position and move both neutral lock latches from the neutral lock position. *Do Not* squeeze both drive levers all the way back, this will cause the drive wheels to be engaged in the reverse direction.

For straight ahead motion, smoothly release both drive levers to engage drive wheels.

Squeeze the right hand drive lever to turn right and the left hand drive lever to turn left.

To make a "zero turn", squeeze either the left hand or the right hand drive lever back into the reverse position while the opposite drive lever is in a forward position at an equal but opposite speed.

To back up, squeeze both drive levers into the reverse position (See Figure 4).

For smooth operation of this machine, avoid quick, jerky movements of the drive levers. Move the drive levers smoothly and deliberately.

- 4.3.5 To Stop: Squeeze drive levers back to the neutral position. Move neutral lock latches into the neutral lock position and release drive levers. Move the speed control lever to the neutral position.

- 4.3.6 Engaging Electric Blade Clutch: The electric blade clutch toggle switch engages the cutting blades. Be sure that all persons are clear of mower deck and discharge area before engaging the blade clutch.

Set throttle to "midway" position. Pull outward on the toggle switch lever and flip toggle switch ahead to the "On" position. Accelerate to full throttle to begin mowing.

- 4.3.7 Stopping Electric Blade Clutch: Flip the toggle switch lever rearward. This moves the toggle switch to the "Off" position to stop the cutting blades.

4.4 TRANSPORTING

Use a heavy duty trailer to transport the machine. Engage neutral lock latches and block wheels.

Securely fasten the machine to the trailer with straps, chains, cables or ropes.

Be sure that the trailer has all necessary lighting and marking as required by law and use a safety chain.

5. MAINTENANCE & ADJUSTMENTS

CAUTION

- Disengage blade clutch, shut off engine and remove key before servicing, cleaning or making adjustments.

CAUTION

- Never do maintenance or repairs near a hot engine. Always allow engine time to cool down.

5.1 PERIODIC MAINTENANCE

5.1.1 Check engine oil level.

Service Interval: See Engine Owner's Manual

- a) Make sure engine is stopped and on a level surface.
- b) Check with engine cool.
- c) Clean area around dipstick. Remove dipstick and wipe oil off. Reinsert the dipstick. **DO NOT** screw into place. Remove dipstick and check oil level.
- d) If the oil level is low, add oil as specified in the Engine Owner's Manual to bring the oil level up to the "F" mark on the dipstick. **DO NOT OVERFILL.**

IMPORTANT: DO NOT operate the engine with oil level below the "L" mark or over the "F" mark.

5.1.2 Clean engine air cooling system.

Service Interval: See Engine Owner's Manual

- a) Stop engine and remove ignition key.
- b) Clean all debris from engine air intake screen and from around engine shrouding.

5.1.3 Clean grass build-up under deck and check mower blades.

Service Interval: Daily

CAUTION

- When it is necessary to raise the deck or mower for service or maintenance, **DO NOT** rely solely on mechanical or hydraulic jacks for support. Use adequate jack stands or equivalent support.
- a) Disengage electric blade clutch.
 - b) Stop engine and remove ignition key.
 - c) Raise deck and block up using proper safety precautions.
 - d) Clean out any grass build-up from underside of deck and in deck discharge chute.
 - e) Inspect blades and sharpen or replace as required.

- f) If blade removal is necessary, be careful for the sharp cutting edges of the blades.
- g) Re-install the blades (if they were removed) and torque blade bolts to 75-80 ft. lbs. Be sure the spring disk washer cone is installed toward the bolt head (See Figure 5).
- h) Remove jack stands (or equivalent support) and lower deck to ground.

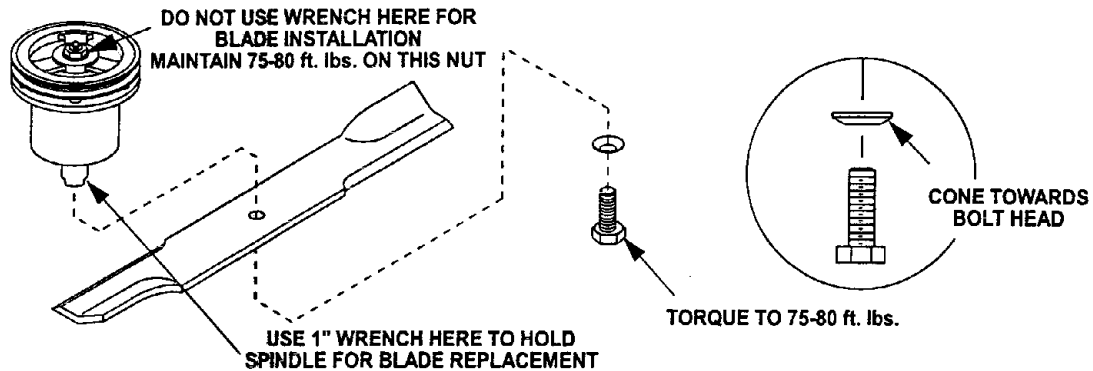

FIG. 5
BLADE BOLT INSTALLATION

5.1.4 Check safety interlock system.

Service Interval: Daily

- a) Check starting circuit. Starter should crank with: *Operator Presence Control levers depressed, speed control lever in neutral, and electric blade clutch disengaged.*

Try to start the engine with *OPC levers disengaged, speed control lever in neutral and electric blade clutch disengaged - starter MUST NOT crank.*

Try to start with, *OPC levers depressed, speed control lever in any speed but neutral and electric blade clutch disengaged - starter MUST NOT crank.*

Try to start with *OPC levers depressed, speed control lever in neutral and electric blade clutch engaged starter MUST NOT crank.*

- b) Check OPC circuits. Clear the area. Run engine at one-third throttle, then, with drive levers and neutral lock latches in *neutral lock position*, move the speed control lever out of neutral and release OPC levers *engine MUST stop.*

Again, run engine at one-third throttle, move the speed control lever to *neutral*, engage electric blade clutch and release OPC levers - *engine MUST stop.*

- c) If machine does not pass any of these tests, **DO NOT** operate. Contact your authorized EXMARK SERVICE DEALER.

 **CAUTION**

- It is essential that all Operator Safety Mechanisms be connected and in proper operating conditions prior to the use of the mower.

 **CAUTION**

- When checking starting problems, be sure to keep clear of areas with moving parts.

5.1.5 Check for loose hardware.

Service Interval: Daily

- a) Stop engine and remove ignition key.
- b) Visually inspect machine for any loose hardware or any other possible problem. Tighten hardware or correct the problem before operating.

5.1.6 Service pre-cleaner element and air cleaner.

Service Interval: See Engine Owner's Manual

 **CAUTION**

- Never do maintenance or repairs near a hot engine. Always allow engine time to cool down.

5.1.7 Change engine oil.

Service Interval: See Engine Owner's Manual

NOTE: Change oil after first five (5) hours of operation.

- a) Disengage electric blade clutch.
- b) Stop engine and remove ignition key.
- c) Drain oil while engine is warm from operation.
- d) Remove the oil drain plug from the right hand side of the engine. Allow oil to drain, then replace drain plug.
- e) Replace the oil filter as per Engine Owner's Manual. Clean around oil filter and unscrew filter to remove. Before reinstalling new filter, apply a thin coating of oil on the surface of the rubber seal. Turn filter clockwise until rubber seal contacts the filter adapter then tighten filter an additional 2/3 to 3/4 turn.
- f) Clean around oil fill cap and remove cap. Fill to the specified capacity and replace cap. Use oil as specified in Engine Owners Manual. *Do not overfill.*
- g) Start the engine and check for leaks. Stop engine and recheck oil level.

5.1.8 Check hydraulic oil level.

Service Interval: 25 hr.

- a) Stop engine.

- b) Clean area around hydraulic reservoir cap and remove cap. Oil level should be to the top of the baffle inside the tank. If not, add oil.

Use only Mobil 1 15W-50 synthetic motor oil.

 **CAUTION**

- Safely relieve all pressure in the system before disconnecting lines or before performing any work the system.

 **CAUTION**

- Make sure all hydraulic fluid connections are tight and all hydraulic hoses and lines are in good condition before applying pressure to the system.

 **CAUTION**

- Keep body and hands away from pin holes or nozzles that eject hydraulic fluid under high pressure. Use paper or cardboard, *NOT HANDS* to search for leaks.

 **CAUTION**

- Hydraulic fluid escaping under pressure may have sufficient force to penetrate skin and cause serious injury. If foreign fluid is injected into the skin, it must be surgically removed within a few hours by a doctor familiar with this type of injury or gangrene may result.

5.1.9 Change hydraulic system filter.

Service Interval: After First 250 hrs, then yearly thereafter.

- a) Place unit on a level surface, stop engine and remove key.
- b) Carefully clean area around filter. It is important that no dirt or contamination enters the hydraulic system.
- c) Unscrew filter to remove and allow oil to drain from reservoir. Before re-installing new filter, fill it completely with Mobil 1 15W-50 and apply a thin coat of oil on the surface of the rubber seal. Turn filter clockwise until rubber seal contacts the filter adapter. Do not tighten yet. Use only Exmark filter element Part No. 513211.
- d) Fill reservoir to top of baffle as stated in Section 5.1.8.
- e) Loosen filter 1/2 turn and allow a small amount of oil to leak from the oil filter (this allows air to be purged from the oil filter and supply hose from the hydraulic reservoir). Turn filter clockwise until rubber seal contacts the filter adapter. Then tighten the filter an additional 2/3 to 3/4 turn. Run machine to allow any other air to be purged from the hydraulic system and recheck the oil level.

- f) If either drive wheel does not rotate, one or both of the charge pumps (located on the top of the main pump as shown in Figure 6) may have lost their "prime". Refer to Section 5.1.10.
- g) *Do not* change hydraulic system oil (except what can be drained when changing filter) unless it is felt that oil has been contaminated. Changing oil unnecessarily could damage the hydraulic system by introducing contaminants into the system.

5.1.10 Hydraulic system air purge procedure.

Air must be purged from the hydraulic system when any hydraulic components, including oil filter, are removed or any of the hydraulic lines are disconnected.

The critical area for purging air from the hydraulic system is between the oil reservoir and each charge pump located on the top of each variable displacement pump. (See Figure 6).

Air in other parts of the hydraulic system will be purged through normal operation once the charge pump is "primed".

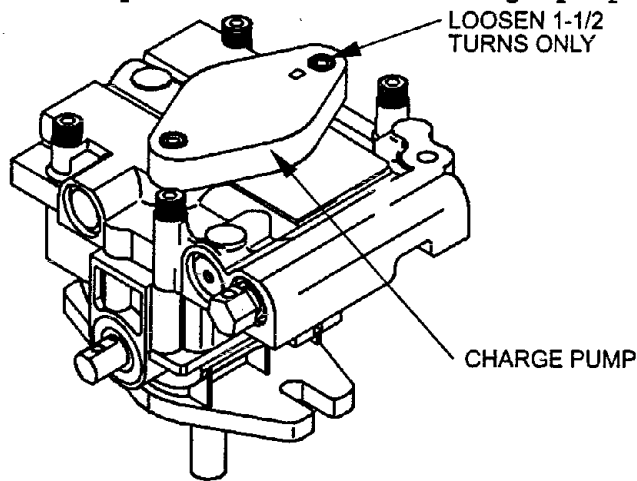

FIG. 6
CHARGE PUMP LOCATION

- a) Stop engine. Raise the rear of the machine up onto jack stands high enough to raise the drive wheels off the ground.
- b) Check oil level as stated in Section 5.1.8.
- c) Thoroughly clean the area around each of the charge pump housings.
- d) To "prime" charge pump, loosen two hex socket head capscrews (shown in Figure 6) 1-1/2 turns only. **Make sure engine is not running.** Lift the charge pump housing upward and wait for a steady flow of oil to flow out from under the housing. Retighten the capscrews. Do this for both pumps.

Note: Hydraulic reservoir can be pressurized up to 5 psi to speed this process.

- e) Start engine and move throttle control ahead to full throttle position. Move the speed control lever to the full speed position and place the drive levers in the "drive" position.

If either drive wheel still does not rotate, stop and repeat steps (d) and (e) above for the respective pump. If wheels rotate slowly, the system may prime after additional running.

- f) Allow unit to run several minutes after the charge pumps are "primed" with drive system in the full speed position. Check oil level as stated in Section 5.1.8.
- g) Check hydro drive linkage adjustment as stated in Section 5.2.5.

5.1.11 Check tire pressures.

Service Interval: 25 hrs.

- a) Stop engine and remove ignition key. Check air pressure in tires; recommended tire pressure is: rear, 12-16 psi; front casters, 22 psi.
- b) Inflate tires to pressures stated above. Measure circumference of each drive tire. Adjust tire pressures within the above range to try to make tire circumferences match as closely as possible. See 3.2.3.

Note: Front caster tires have permanent tire sealant installed.

5.1.12 Check battery electrolyte level.

Service Interval: 25 hrs.



- Be sure ignition is "OFF" and key is removed before disconnecting or installing the battery.
- Keep sparks and flame away from battery at all times.

- a) Stop engine and remove ignition key.
- b) Remove battery cover.
- c) Remove vent caps from battery. If needed, fill with water (distilled is recommended) to bottom of vent wells and replace vent caps.
- d) See Section 3.5 for servicing a new battery.

5.1.13 Inspect Belt wear.

Service Interval: 25 hrs.

- a) Stop engine and remove ignition key.
- b) Remove the three cutter deck belt shields to check mower primary and secondary belt condition.
- c) Look under engine deck to check the pump drive belt condition.

d) Check all idler arms to be sure they pivot freely.

5.1.14 Lubrication

a) Stop engine and remove ignition key.

b) Lubricate fittings with one to two pumps of SAE No. 2 multi-purpose gun grease (see recommended lubricants) following the lubrication chart.

Refer to the following chart for fitting locations and lubrication schedule.

LUBRICATION CHART

FITTING LOCATIONS	INITIAL PUMPS	No. of PLACES	SERVICE INTERVAL
1. Caster Wheel Bearings	12	2	Daily
2. Caster Pivots	2	2	Daily
3. Cutter Housing Spindles	10	3	† Weekly
4. Idler Pivots (Mower Deck)	1	2	Weekly
5. Idler Pivot (Pump Drive)	2	1	Weekly
6. Hydro Control Arm Support Bushings	2	2	Weekly

† Under severe cutting conditions, two pumps of grease twice weekly may be more beneficial.

Recommended SAE No. 2 Greases:

Pennzoil #705; Pennzoil #707L; Pennzoil #TTM 302

Mobil Grease CM-P; Mobilith SHC220;
Mobil Grease Special; Mobilith SHC460
(Available at Mobil Stations)

Ronex MP - (Available at Exxon Stations)

Shell Alvania #2 - (Available at Shell Stations)

Super Lube M EP #2 or Super Stay M #2
(Available at Conoco Stations)

5.1.15 Check spark plugs.

Service Interval: 100 hrs.

a) Remove spark plugs, check condition and adjust plug gap or replace with new plugs. See Engine Owner's Manual.

5.1.16 Remove engine shrouds and clean cooling fins.

Service Interval: See Engine Owner's Manual

a) Stop engine and remove ignition key.

b) Remove cooling shrouds from engine and clean cooling fins. Also clean dust, dirt and oil from external surfaces of engine which can cause improper cooling.

- c) Make sure cooling shrouds are properly reinstalled. Operating the engine without cooling shrouds will cause engine damage due to overheating.

5.1.17 Change fuel filter.

Service Interval: **As Required**

- a) A fuel filter is installed in the fuel line between the fuel tank and the engine. Replace when necessary.

5.1.18 Wheel hub - slotted nut torque specification.

When tightening the slotted nut on the wheel motor tapered shaft:

- a) To aid in wheel hub removal, it is recommended that an anti-sieze compound is used on the tapered shaft of the wheel motor.
- b) Torque the slotted nut to 100 ft. lbs.
- c) Further tighten the nut until the next set of slots line up with the cross hole in the shaft.
- d) Replace cotter pin.

5.1.19 Thread locking adhesives such as "Loctite 242" or "Fel-Pro, Pro-Lock Nut-Type" are used on the following fasteners:

- a) Pump drive pulley setscrews.
- b) Square head setscrews on Hydro pump control arms.
- c) Shoulder bolts in ends of speed control crank.
- d) Shoulder bolts connecting Hydro control linkages to Hydro pump control arms.
- e) OPC lever setscrews.
- f) Electric clutch retaining bolt.
- g) Pump drive idler pivot bolt.

Adhesives such as "Loctite RC/609 or RC/680" or "Fel-Pro Pro-Lock Retaining I or Retaining II" are used on the following:

- a) OPC lever hubs and cross-shaft

NOTE: Care must be used not to bond the bearing, next to each OPC hub, to the cross shaft which could cause binding of the OPC levers and erratic operation.

5.1.20 An anti-seize compound is used on tapered shaft of wheel hub mounts.

5.1.21 Dielectric grease is used on all blade type electrical connections to prevent corrosion and loss of contact.

5.2 ADJUSTMENTS

CAUTION

- Disengage blade clutch, shut off engine and remove key before servicing, cleaning or making adjustments.

5.2.1 Cutting height and anti-scalp roller adjustment.

CAUTION

- Front end of support frame may rise up suddenly if not held down securely when the front two deck support rod hairpins are removed.
- a) Install hairpin clips in the holes shown on sketch below for the desired cutting height (See Figure 7).

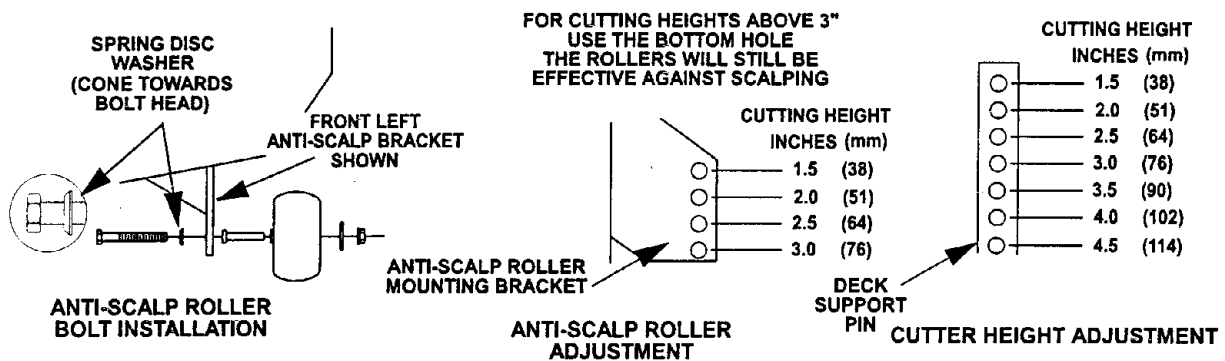

FIG 7

ANTI-SCALP ROLLER BOLT INSTALLATION
ANTI-SCALP ROLLER ADJUSTMENT
CUTTING HEIGHT ADJUSTMENT

- b) For maximum deck flotation, rollers should maintain 1/4 in. (6.4 mm) clearance to ground. Do Not adjust rollers to support the deck. Be sure roller bolts and nuts are installed with the spring disc washer between head of the bolt and mounting bracket (See Figure 7). Torque to 40-45 ft-lbs, or loss of roller may result.
- c) When operating in extremely rough conditions it may be necessary to position the anti-scalp rollers one or two holes higher than described in "b" to prevent damage to the rollers and/or bolt failure (See Figure 7).

NOTE: When anti-scalp rollers are placed in these positions, reduced deck flotation will result.

5.2.2 Pump drive belt tension adjustment:

No adjustment necessary.

5.2.3 Cutter deck drive belt:

No adjustment necessary.

5.2.4 Blade drive belt tension:

No adjustment necessary.

5.2.5 Hydro Drive Linkage Adjustment:

a) Adjust Speed Control Linkage

1. Stop engine.
2. Move speed control lever (located on console) to the full forward position and check orientation of tabs on the ends of the speed control crank (fig. 8). These tabs should be pointing straight down at the 6 o'clock position or slightly forward. Adjust threaded yoke at the bottom of speed control linkage (fig. 8) until tabs are positioned correctly.
3. Pull speed control lever back to neutral. Check that the dimension between the bottom forward tip of neutral switch actuating tab (located at the left hand rear corner of fuel tank) and the top of the fuel tank support is $7/8$ " (fig. 8). If it is not, bend tab on speed control crank to attain $7/8$ " dimension.

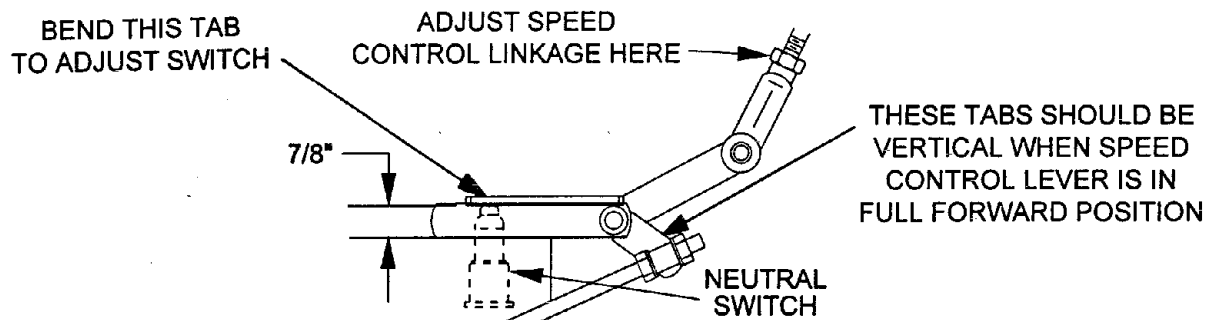

FIG. 8
SPEED CONTROL LINKAGE LENGTH
ADJUSTMENT OF $7/8$ " DIMENSION

b) Adjust Neutral Control Linkages

1. Raise the rear of the machine up onto jack stands high enough to raise the drive wheels off of the ground.
2. Start the engine and move the throttle ahead to the full throttle position. Place the neutral lock levers in the drive position as shown in Figure 4 and move the speed control lever to the "mid-speed" position.

Note: The OPC levers must be held down whenever the speed control lever is out of the neutral position of the engine will kill.

3. Squeeze the respective drive lever until an increased resistance is felt; this is where neutral should be. Make sure you have not reached the end of the thumb latch slot. If you have, shorten the drive lever linkage. If the wheel turns while holding the drive lever in neutral, the neutral control linkages need to be adjusted. If wheels stop then go to step 7.

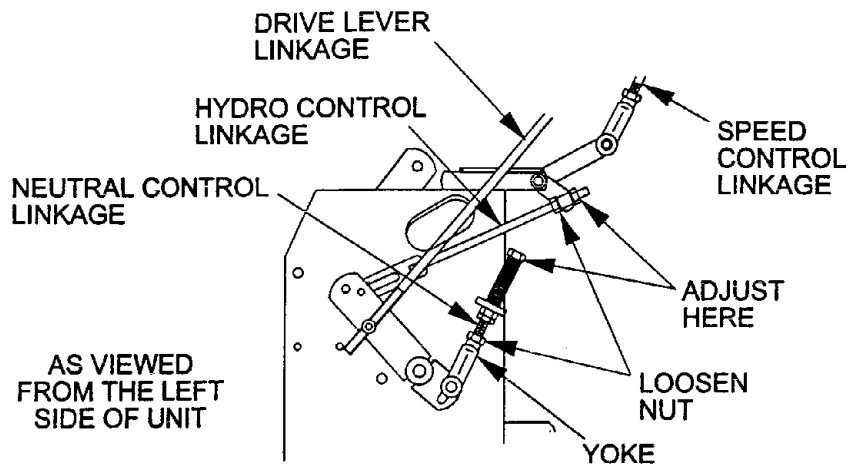

FIG. 9

HYDRO DRIVE LINKAGE ADJUSTMENT

4. Loosen the nut against the yoke as shown in Figure 9.
5. Adjust the neutral control linkage until the respective drive wheel stops when the lever is pulled against the neutral spring (neutral position). Turn the adjusting bolt clockwise if the wheel is turning in reverse or turn the bolt counter-clockwise if the wheel is turning forward. Release the drive lever to the forward drive position and squeeze back into the neutral position. Check to see if the wheel stops. If not, repeat the above adjustment procedure.
6. Make this adjustment on both sides.
7. After adjustments are made and the wheels stop when the drive lever is in the neutral position, tighten the nut against the yoke.

c) Adjust Hydro Control Linkage:

1. Place the speed control lever in the "neutral" position. This adjustment is again made with rear of machine on jack stands and engine running at full throttle. OPC levers will have to be held down whenever speed control lever is moved out of neutral position.
2. Loosen the front nut on left hydro control link as shown in Figure 9. Turn the rear control linkage adjusting nut counter-clockwise until wheel rotates forward). Turn the rear nut of left control link clockwise 1/6 of a turn at a time, stopping to move the speed control forward and back to neutral, until left wheel stops rotating forward. Turn the nut an additional 1/2 turn and tighten the front jam nut making sure not to put a bind on the linkage. Make sure flat part of linkage is perpendicular to pin part of swivel. See Fig. 10.

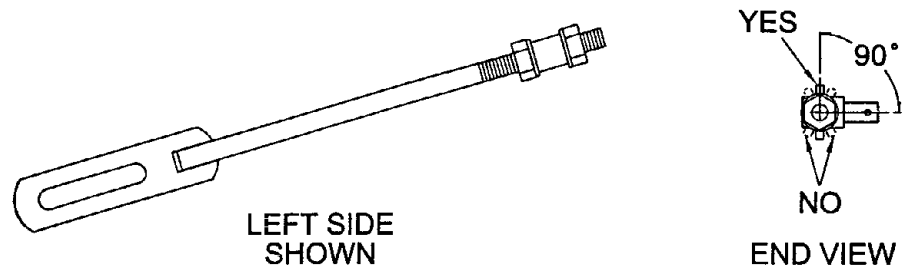

FIG. 10

HYDRO CONTROL LINKAGE/SWIVEL ADJUSTMENT

After adjusting the left hydro control linkage, move the speed control lever to the mid-speed position and then back to the neutral position. Recheck the left drive wheel rotation to see if further adjustment is necessary - be sure the speed control lever is in the neutral position.

If inconsistent neutral occurs, check to be sure both springs are properly tightened on the speed control lever under the console - especially the rear pivot spring.

Repeat above adjustments if necessary.

3. Place the speed control lever in neutral. Adjust the right side linkage by turning the quick track knob counter-clockwise until the tire begins to rotate forward. Begin to retighten the knob clockwise about 1/4 turn at a time, stopping to move the speed control forward and back to neutral. Recheck the drive wheel rotation to see if further adjustment is necessary.
4. The spring that keeps tension on the knob should normally not need adjustment. However, if adjustment is needed, adjust to where length of spring is about 1" between washers. Adjust spring length by turning nut at front of spring.

d) Drive Lever Linkage Adjustment

1. With rear of machine still on jack stands and engine running at full throttle, move the speed control lever to the midway position. Move the respective drive lever upward until it reaches the **neutral** position and engage neutral lock latches. See fig. 11. If the tire rotates in either direction, the length of the drive lever linkage will need to be adjusted.

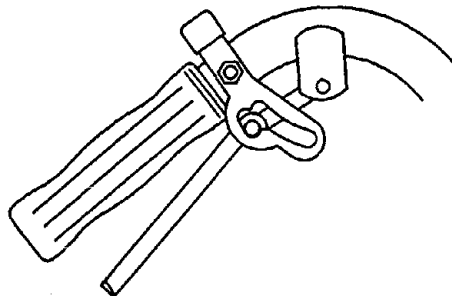

FIG. 11

DRIVE LEVER AND LATCH IN NEUTRAL POSITION

3. Adjust the linkage length by releasing the drive lever and removing clevis pin and rotating the linkage in the lower swivel. Lengthen the linkage if the tire is turning in reverse and shorten the linkage if the tire is creeping forward. Rotate the linkage several turns if the tire is rotating fairly fast. But as the adjustment gets closer, adjust the linkage in 1/2 turns. Release and re-engage neutral lock latch checking that the tire stops. Continue these process until the tire is at a dead stop.
 4. Replace the hairpin back into each clevis pin.
 5. Make this adjustment for both sides.
- e) Tracking Adjustment
1. Stop engine, raise rear of machine, remove jack stands and carefully lower machine to the ground.
 2. Check the drive tire pressures and tire circumferences. See 5.1.11.
 3. Run the unit and observe the tracking on a level, smooth, hard surface such as concrete or asphalt.
 5. If the unit tracks to one side or the other, turn the quick track knob. Turn the knob right to "steer" right, turn the knob left to "steer" left.

5.2.6 Hydro Pump Spring Tension Setting

- a) For medium or heavy duty drive conditions such as operation with a sulky on steep slopes, a higher spring force may be required on the hydro pump control arms to prevent the drive system from stalling.
 - b) For a heavier drive setting, relocate the spring anchor link as shown in Figure 12. The spring anchor links are located under the engine deck on the left and right hand sides.
- Note:** In "medium" or "heavy duty" positions, the drive lever forces at the upper handle will also be increased.

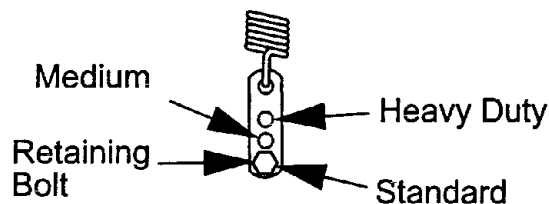

FIG. 12

HYDRO PUMP SPRING TENSION SETTING

5.2.7 Throttle Control Adjustment

- a) Loosen cable clamp on engine and position throttle control (at the control console) within 1/8" from the upper end of the slot. Pull on cable assembly at lower end where it attaches to the engine until the throttle control arm contacts the stop screw. Secure cable with cable clamp.
- b) Tension in throttle lever can be adjusted by adjusting the tightness of the lever pivot bolt, which is located under the console.

5.2.8 Electric Clutch Adjustment

No adjustment necessary.

6. TROUBLE SHOOTING

6.1 MOWER TRACKS TO LEFT OR RIGHT.

- a) Check the drive tire pressures and tire circumferences.
See 5.1.11.
- b) Turn knob on the right hydro control linkage in the direction that the mower needs to be adjusted to. Turn the knob in 1/4 turn increments until the mower tracks correctly.

6.2 MOWER CUTS UNEVENLY.

- a) Check the drive tire pressures and tire circumferences.
See 5.1.11.

A more uniform cutting height may be obtained with higher tire pressure on rough terrain. A lower tire pressure provides more flotation.
- b) Check deck support pins. Hairpin clips must be in the same hole position on each support pin.
- c) Check deck support alignment and check mounting brackets to be sure all bolts are tight.
- d) Check blades tip to tip for straightness. (They should be within 3/16", or one blade width from being in line.)

6.3 ENGINE WILL NOT START.

- a) Check that the throttle control is midway between "slow" and "fast" positions, and choke is in "on" position for a cold engine or "off" position for a warm engine.
- b) Make sure transmission is in "true neutral" position.
(See Section 5.2.5)
- c) Check that the blades are disengaged.
- d) Make sure the "OPC" levers are depressed.
- e) Check that there is fuel in the tank and that the fuel valve is open.
- f) Check that the spark plug wires are properly connected.
- g) Check for loose or faulty wiring connections. If it is necessary to disconnect wire connectors, Do Not pull on the wires.
- h) Check for corrosion at all wiring connections.
Even minor corrosion may cause a faulty connection.
Clean connector terminals thoroughly, apply dielectric grease and reconnect.

CAUTION

- It is essential that all operator safety mechanisms be connected and in proper operating condition prior to mower use.

NOTE: After carefully checking the above steps, attempt to start the engine. If it does not start, contact contact your authorized Exmark service dealer.

ENGINE TROUBLESHOOTING

CAUTION

- When checking starting problems, be sure to keep body, hands and clothes away from areas where moving parts can suddenly engage.

CAUTION

- When performing maintenance, servicing or repairing the unit, allow the engine ample time to cool down. Serious burns can result from hot metal.

When a problem occurs, do not overlook the simple causes. For example, starting problems could be caused by an empty fuel tank.

The following tables list some of the common causes of trouble.

Do not attempt to service or replace major items or any items that call for special timing or adjustment procedures (such as valves, governor, etc.). Have this work done by your Engine Service Dealer.

ENGINE TROUBLESHOOTING TABLE

PROBLEM	NO FUEL	IMPROPER FUEL	DIRT IN FUEL LINE	DIRTY AIR FILTER	FAULTY SPARK PLUG	ENGINE OVERLOADED	BLOCKED FUEL FILTER	INCORRECT OIL LEVEL	DIRTY AIR SCREEN
Will not start	X		X	X	X	X	X		
Hard starting	X	X	X	X	X	X	X		
Stops suddenly	X		X	X		X	X	X	X
Lacks power		X	X	X	X	X	X	X	X
Operates erratically		X	X	X	X	X	X		X
Knocks or pings		X				X			X
Skips or misfires		X	X	X	X				X
Backfires			X	X	X	X			X
Overheats			X	X		X		X	X
High fuel consumption				X	X	X			X

7. HYDRAULIC SCHEMATIC

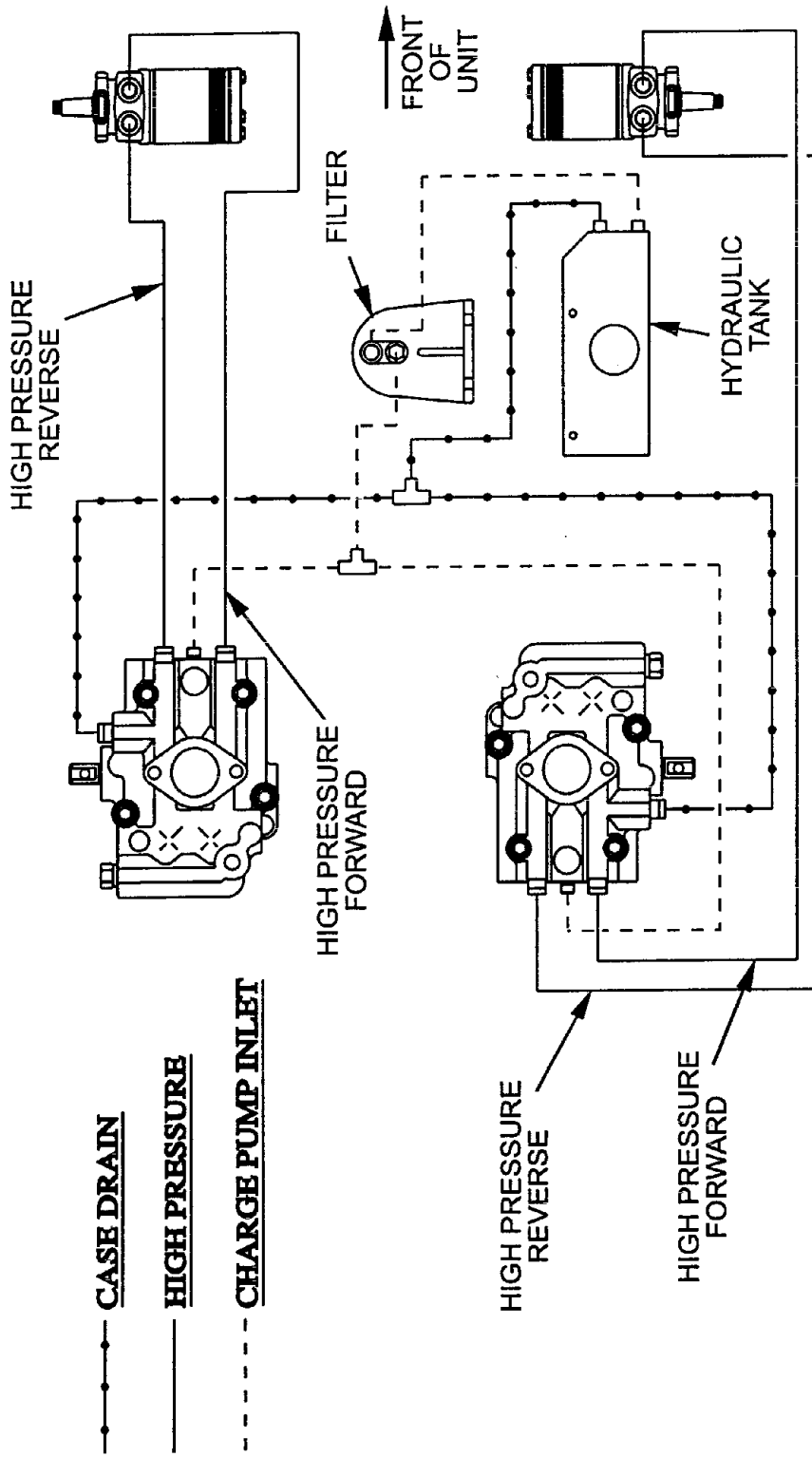

8. WIRING DIAGRAMS

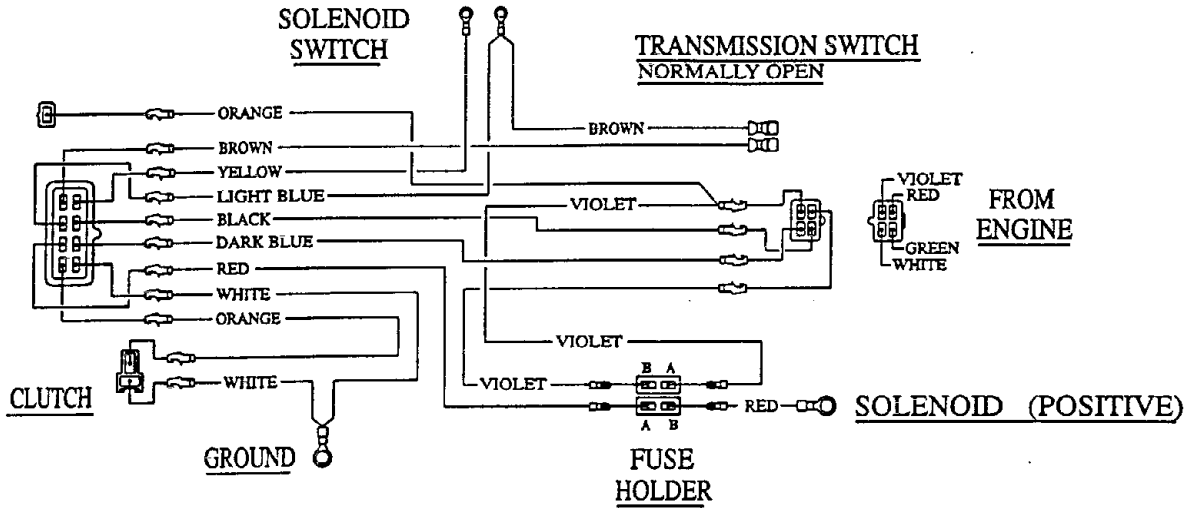

Engine Deck Wiring Diagram

NOTE: All connectors are viewed from the *wire input* side of the connector.

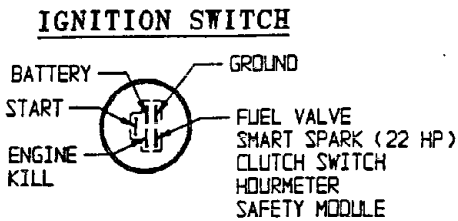
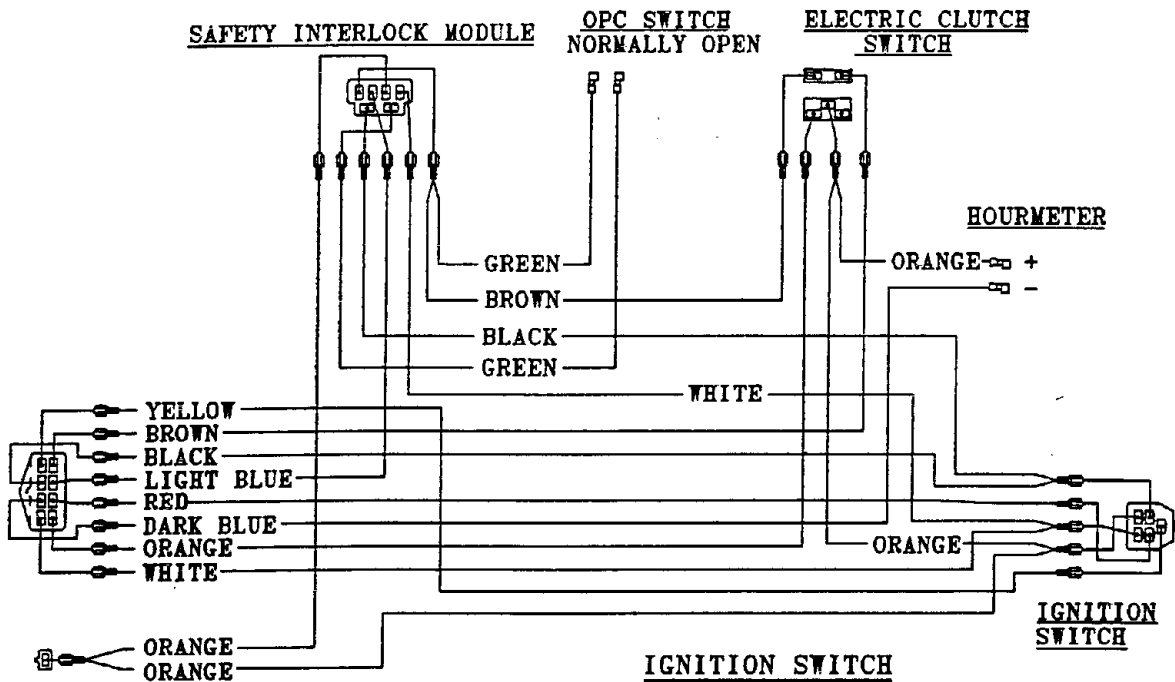

POSITION	CIRCUIT "MAKE"
OFF	GROUND + ENGINE KILL
ON	BATTERY + FUEL VALVE + SMART SPARK (22HP) + CLUTCH SWITCH + HOURLMETER + SAFETY MODULE
START	BATTERY + START + BATTERY + FUEL VALVE + SMART SPARK (22 HP) + CLUTCH SWITCH + HOURLMETER + SAFETY MODULE

Console Wiring Diagram

NOTE: All connectors are viewed from the *wire input* side of the connector.

9. WARRANTY

Limited Warranty Exmark Commercial Turf Equipment Exmark Mfg. Co. Inc. ("Exmark") warrants on the terms and conditions herein, that it will repair, replace or adjust any part manufactured by Exmark and found by Exmark (in the exercise of its reasonable discretion) to be defective in factory material or workmanship.

This warranty is limited to one year from the date of original retail purchase (90 days for rental use) for any Exmark mower that is used for commercial or any other income producing purpose. The hydrostatic traction drive system will be warranted for two full years from date of original retail purchase against defects in materials or workmanship excluding hoses. Exmark Mfg will extend the Peerless 5-speed transmission manufacturer's warranty from 90 days to one year. Belts and tires are warranted for 90 days against defects in materials or workmanship.

The engine warranty is covered by its respective engine manufacturer. Please refer to the engine manufacturers warranty statement that is included in the literature packet. Exmark is not authorized to handle warranty adjustments on engines. Engine warranties should be referred to the nearest authorized service outlet of the engine manufacturer.

This warranty extends only to the original retail purchaser of the equipment. The warranty may not be assigned or transferred without the prior express written consent of Exmark. The warranty commences upon the date of the original retail purchase.

The Exmark turf equipment, including any defective part, must be returned to an authorized Exmark service dealer within the warranty period. The warranty shall extend to cost to repair or replace (as determined by Exmark) the defective part, including labor. The expense of delivering the mower to the dealer for warranty work and the expense of returning it back to the owner after repair or replacement will be paid for by the owner. Exmark's responsibility in respect to claims is limited to making the required repairs or replacements, and no claim of breach of warranty shall be cause for cancellation or rescission of the contract of sale of any Exmark mower. Proof of purchase may be required by the dealer to substantiate any warranty claim. All warranty work must be performed by an authorized Exmark service dealer.

This warranty extends only to turf equipment operated under normal conditions and properly serviced and maintained. The warranty expressly does not cover: (i) any defects, damage or deterioration due to normal use, wear and tear, or exposure; (ii) normal maintenance services, such as oil change, cleaning, lubrication, adjustment; (iii) replacement of service items, such as oil, lubricants, spark plugs, belts, rubber hoses or other items subject to normal service replacement; (iv) damage or defects arising out of or relating to misuse, neglect, alteration, negligence or accident; (v) repair or replacement arising from operation of or use of the turf equipment which is not in accordance with operating instructions as specified in the operator's manual or other operational instructions provided by Exmark; (vi) repair or replacement arising as a result of any operation from turf equipment that has been altered or modified so as to, in the determination of Exmark, adversely affect the operation, performance or durability of the equipment or that has altered, modified or affected the turf equipment so as to change the intended use of the product; (vii) repair or replacement necessitated by use of parts, accessories

or supplies, including gasoline, oil or lubricants, incompatible with the turf equipment or other than as recommended in the operator's manual or other operational instructions provided by Exmark; (viii) repairs or replacements resulting from parts or accessories which have adversely affected the operation, performance or durability of the turf equipment; or (ix) damage or defects due to or arising out of repair of turf equipment by person or persons other than an authorized Exmark service dealer or the installation of parts other than genuine Exmark or Exmark recommended parts.

As a condition to this warranty, customer shall have read the operator's manual and shall have returned to Exmark, within the prescribed time, the enclosed warranty registration card.

The sole liability of Exmark with respect to this warranty shall be repair and replacement as set forth herein. Exmark shall have no liability for any other cost, loss or damage, including but not limited to, any incidental or consequential loss or damage. In particular, Exmark shall have no liability or responsibility for: (i) expenses relating to gasoline, oil or lubricants; (ii) loss, cost or expense relating to transportation or delivery of turf equipment from the location of owner or location where used by owner to or from any authorized Exmark service dealer; (iii) travel time, overtime, after hours time or other extraordinary repair charges or charge relating to repairs or replacements outside of normal business hours at the place of business of the authorized Exmark service dealer; (iv) rental of like or similar replacement equipment during the period of any warranty, repair or replacement work; (v) any telephone or telegram charges or travel charges; (vi) loss or damage to person or property other than that covered by the terms of this warranty; (vii) any claims for lost revenue, lost profit or additional cost as a result of a claim of breach of warranty; or (viii) attorney's fees.

There are no representations or warranties which have been authorized and provided to the buyer of the turf equipment, other than as set forth in this warranty. Any and all statements or representations made by any seller of this equipment, including those set forth in any sales literature or made orally by any sales representative, are superseded by the terms of this warranty. Any affirmation of fact or promise made by Exmark or any of its representatives to the buyer which relates to the goods that are the subject of this warranty shall not be regarded as part of the basis of the bargain and shall not be deemed to create any express warranty that such goods shall conform to the affirmation or promise.

THERE ARE NO UNDERSTANDINGS, AGREEMENTS, REPRESENTATIONS, OR WARRANTIES, EXPRESS OR IMPLIED (INCLUDING BUT NOT LIMITED TO ANY REGARDING THE MERCHANTABILITY OR FITNESS FOR A PARTICULAR PURPOSE), NOT SPECIFIED HEREIN, RESPECTING THE EQUIPMENT WHICH IS THE SUBJECT OF THIS WARRANTY.

This warranty applies to all Exmark turf equipment sold in the United States and Canada and intended to be used for commercial purposes.

NOTES

**SEE EXMARK'S COMPLETE
LINE OF PRODUCTS FOR TURF CARE**

LAZER Z

EXPLORER

TURF RANGER

TURF TRACER HYDRO

TURF TRACER HP

VIKING 5-SPEED

VIKING HYDRO

METRO

SELF STEERING SULKY

GRASS CATCHER

MICRO-MULCHING ACCESSORY

**EXMARK MFG. CO. INC.
INDUSTRIAL PARK BOX 808
BEATRICE, NE. 68310**

ALL RIGHTS RESERVED

**PART NO. 850437
(402) 223-4010
FAX (402) 223-4154**

PRINTED IN U.S.A.

