

For Serial Nos.  
600,000 & Higher

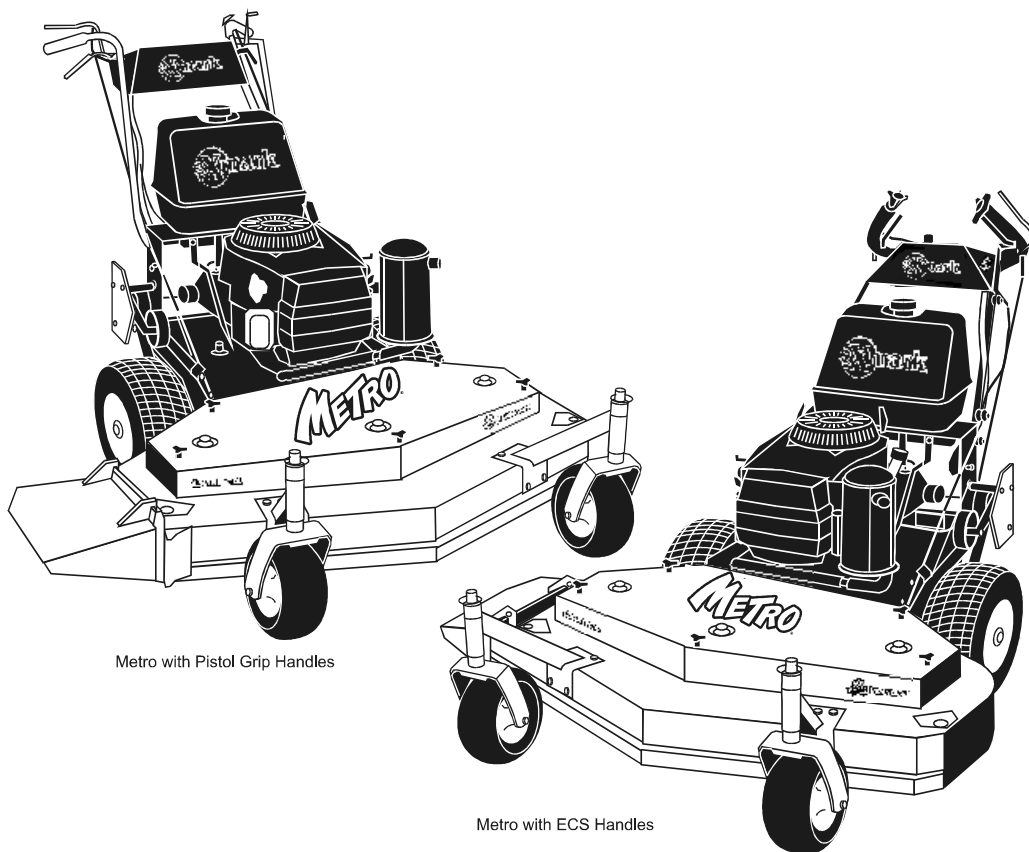

# METRO<sup>®</sup>

# OPERATOR'S MANUAL

**CONGRATULATIONS** on the purchase of your new Exmark mower. This product has been carefully designed and manufactured to give you a maximum amount of dependability and years of trouble-free operation. If additional information is needed, or should you require trained mechanic service, contact your authorized Exmark equipment dealer or distributor. If you need to order replacement parts from your dealer, always give the model number and serial number of your mower as well as the part number, description and quantity of the part needed.

The Serial No. plate is located on the top front engine frame on the right hand side of the machine. For ease of ordering and reference, we suggest that you record the information requested in the following identification table.

Place Model No. and Serial No. Label Here  
(Included in Literature Pack)  
or Fill in Below

Model No. \_\_\_\_\_

Serial No. \_\_\_\_\_

Engine Model No. and Spec. No. (Code) \_\_\_\_\_

Engine Serial No. (E/No) \_\_\_\_\_

Date Purchased \_\_\_\_\_

## **WARNING**

### POTENTIAL HAZARD

- ◆ This product is a piece of power equipment.

### WHAT CAN HAPPEN

- ◆ Failure to follow safe operating practices can result in serious operator injury or even death.

### HOW TO AVOID THE HAZARD

- ◆ Keep all shields, guards, and safety devices (especially the grass discharge system) in place and in proper working condition.
- ◆ Stop engine and wait for all moving parts to stop. Remove spark plug wire(s) or remove key before adjusting, servicing, or performing maintenance.
- ◆ If mower deck becomes clogged, stop engine and wait for all moving parts to stop. Remove spark plug wire(s) or remove key before cleaning blockage.
- ◆ Keep hands, feet, and clothing away from power driven parts.
- ◆ Keep off mower unless seat platform is provided.
- ◆ Keep others off mower.

## **WARNING**

### POTENTIAL HAZARD

- ◆ Gasoline is harmful or fatal if swallowed. Long-term exposure to vapors has caused cancer in laboratory animals.

### WHAT CAN HAPPEN

- ◆ Failure to use caution may cause serious injury or illness.

### HOW TO AVOID THE HAZARD

- ◆ Avoid prolonged breathing of vapors.
- ◆ Keep face away from nozzle and gas tank/container opening.
- ◆ Keep away from eyes and skin.
- ◆ Never siphon by mouth.

## **IMPORTANT**

When the mower is used or operated on any California forest, brush or grass covered land, a working spark arrester must be attached to the muffler. If not, the operator is violating state law, Section 4442 Public Resource Code. To acquire a spark arrester for your unit, see your Engine Service Dealer.

This spark ignition system complies with Canadian ICES-002

Ce système d'allumage par étincelle de véhicule est conforme à la norme NMB-002 du Canada

**The enclosed Engine Owner's Manual is supplied for information regarding The U.S. Environmental Protection Agency (EPA) and the California Emission Control Regulation of emission systems, maintenance and warranty.**

**Keep this engine Owner's Manual with your unit. Should this engine Owner's Manual become damaged or illegible, replace immediately. Replacements may be ordered through the engine manufacturer.**

Exmark reserves the right to make changes or add improvements to its products at any time without incurring any obligation to make such changes to products manufactured previously. Exmark, or its distributors and dealers, accept no responsibility for variations which may be evident in the actual specifications of its products and the statements and descriptions contained in this publication.

# EXMARK PARTS PLUS® PROGRAM

EFFECTIVE DATE: September 1, 1995

## Program

If your Exmark dealer does not have the Exmark part in stock, Exmark will get the parts to the dealer the next business day or the part will be FREE\* Guaranteed!!

## *How the Program Works*

1. If dealer does not have part in stock for a "down" unit at the time of request by customer, the dealer contacts his distributor by 1:00 p.m., local time, and requests Exmark Parts Plus® shipment of six (6) line items or less.
2. Distributor ships part(s) to dealer or customer, as requested by dealer, same day, overnight UPS. Distributor bills dealer for part and freight charges where applicable.
3. If distributor does not have the part(s) in stock to satisfy Exmark Parts Plus® order, he contacts Exmark by 3:00 p.m., central time, with an Exmark Parts Plus® order of six (6) line items or less.
4. If order is received by 3:00 p.m. central time, Exmark ships part(s) direct to dealer or customer, as requested by distributor, same day, overnight UPS, Exmark bills the distributor for parts and shipping charges, where applicable.
5. The customer pays for the part and freight if it is shipped under the Exmark Parts Plus® and if it arrives in accordance to the program.
6. Who pays for the part and freight if it fails to arrive overnight in accordance to the program?
  - A. Under any circumstance the customer does not pay.
  - B. If the part does not arrive overnight due to:
    1. The dealer not submitting the Exmark Parts Plus® order to his Exmark distributor by 1:00 p.m., the dealer pays for the part and freight.
    2. The Distributor being unable to ship the part the same day or not submitting the Exmark Parts Plus® order to Exmark by 3:00 p.m., central time, the Distributor pays for the part and freight.
    3. Exmark being unable to ship the part and the Exmark parts order is received by 3:00 p.m., central time, Exmark pays for the part and freight.
    4. If the part does not arrive overnight due to the shipper (UPS), the shipper pays for the freight and Exmark pays for the part.

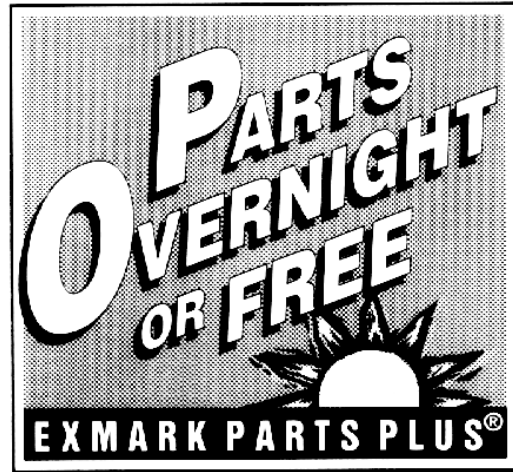

**The following restrictions apply** -- The Exmark Parts Plus® Program is available only through participating Exmark Dealers and applies only to orders submitted on this program Monday through Thursday. Parts Plus service is available only in the 48 contiguous United States. UPS has initiated a Saturday delivery program to many areas of the continental United States and can be requested for an overnight shipment on Friday to be delivered Saturday. The next day air charge, plus the Saturday delivery fee will be the responsibility of the purchaser. Exmark Mfg. will assume no responsibility for Saturday delivery shipments. To qualify, all Exmark Parts Plus® orders must be received by Exmark by 3:00 p.m., central time. Orders must be six (6) line items or less. Exclusions from the Exmark Parts Plus® Program are: Any wholegood or accessory in its entirety, engines and engine replacement parts, 5-speed Peerless transmissions and 5-speed transaxles, hydraulic or hydrostatic wheel motors, cutter decks and engine decks or any item exceeding United Parcel Service size and weight restrictions.

Due to UPS restrictions, aerosol spray paint is considered a hazardous material and cannot be shipped via UPS next day or Second Day Air.

Exmark Manufacturing stocks a limited supply of parts for transaxles, pumps and wheel motors. These parts can be ordered for Next Day Air shipment but will not be guaranteed per the Parts Plus Program.

**CONGRATULATIONS** on the purchase of your Exmark Mower. This product has been carefully designed and manufactured to give you a maximum amount of dependability and years of trouble-free operation.

## **OPERATOR'S MANUAL**

This manual contains assembly, operating, maintenance, adjustment, and safety instructions for your Exmark mower.

**BEFORE OPERATING YOUR MOWER, CAREFULLY READ THIS MANUAL IN ITS ENTIRETY.**

By following the operating, maintenance, and safety instructions, you will prolong the life of your mower, maintain its maximum efficiency, and promote safe operation.

If additional information is needed, or should you require trained mechanic service, contact your authorized Exmark equipment dealer or distributor.

All Exmark equipment dealers and distributors are kept informed of the latest methods of servicing and are equipped to provide prompt and efficient service in the field or at their service stations. They carry ample stock of service parts or can secure them promptly for you from the factory.

All Exmark parts are thoroughly tested and inspected before leaving the factory, however, attention is required on your part if you are to obtain the fullest measure of satisfaction and performance.

# TABLE OF CONTENTS

<b>1. SAFETY</b>	<b>PAGE</b>
1.1 Safety Alert Symbol .....	1
1.2 Training.....	1
1.3 Preparation .....	1-3
1.4 Operation.....	3-6
1.5 Maintenance & Storage.....	6
1.6 Riding Attachments.....	6
1.7 Safety Signs.....	6-8
<b>2. SPECIFICATIONS</b>	
2.1 Model Numbers.....	9
2.2 Engine.....	9
2.3 Fuel System.....	9
2.4 Safety Interlock System .....	9
2.5 Steering/Brake Control.....	9
2.6 Transmission .....	9
2.7 Wheel Drive System .....	9
2.8 Tires.....	9
2.9 Deck .....	9-10
2.10 Dimensions .....	10
2.11 Bolt Torque Requirements .....	10
<b>3. OPERATION INSTRUCTIONS</b>	
3.1 Controls .....	10-12
3.2 Pre-Start .....	12
3.3 Operating Instructions.....	13-16
3.4 Transporting.....	16
<b>4. MAINTENANCE &amp; ADJUSTMENTS</b>	
4.1 Periodic Maintenance.....	17-24
4.2 Adjustments.....	24-30
<b>5. WASTE DISPOSAL</b>	
5.1 Motor Oil Disposal.....	30
<b>6. TROUBLE SHOOTING</b>	
6.1 Mower Tracks Left or Right.....	30-31
6.2 Mower Cuts Unevenly .....	31
6.3 Blades Do Not Stop When Disengaged .....	31
6.4 Engine Will Not Start.....	31-32
<b>7. BELT ROUTING (MOWER DECKS)</b> .....	32
<b>8. WIRING DIAGRAM</b> .....	32
<b>9. WARRANTY</b> .....	33
<b>10. EVAPORATIVE EMISSION CONTROL WARRANTY</b> .....	34

# 1. SAFETY

## 1.1 SAFETY ALERT SYMBOL

This SAFETY ALERT SYMBOL  is used both in this manual and on the machine to identify important safety messages which must be followed to avoid accidents. This symbol means:

**ATTENTION! BECOME ALERT!**  
**YOUR SAFETY IS INVOLVED!**

The safety alert symbol appears above information which alerts you to unsafe actions or situations and will be followed by the word **DANGER**, **WARNING**, or **CAUTION**.

**DANGER:** White lettering/Red background. Indicates an imminently hazardous situation which, if not avoided, **WILL** result in death or serious injury.

**WARNING:** Black lettering/Orange background. Indicates a potentially hazardous situation which, if not avoided, **COULD** result in death or serious injury.

**CAUTION:** Black lettering/Yellow background. Indicates a potentially hazardous situation which, if not avoided, **MAY** result in minor or moderate injury.

## 1.2 TRAINING

- 1.2.1 Regard the Exmark mower as a piece of power equipment and teach this regard to all who operate this unit.
- 1.2.2 Read the instructions carefully. Familiarize yourself with the controls and the proper use of the equipment. If the operator(s) or mechanic(s) can not read English it is the owner's responsibility to explain this material to them.
- 1.2.3 Do not allow operation of this machine by untrained personnel. Never allow children, teenagers, or people unfamiliar with these instructions to use the mower. Local regulations may restrict the age of the operator.
- 1.2.4 Avoid mowing while people, especially children, or pets, are nearby. Keep in mind that the operator or user is responsible for accidents or hazards occurring to other people or their property.

## 1.3 PREPARATION

- 1.3.1 Evaluate the terrain to determine what accessories and attachments are needed to properly and safely perform the job. Only use accessories and attachments approved by Exmark.
- 1.3.2 The use of personal protective equipment, such as (but not limited to) protection for the eyes, ears, feet, and head is recommended.

 <b>CAUTION</b>	
POTENTIAL HAZARD	◆ This machine produces sound levels in excess of 85 dBA at the operator's ear when in operation.
WHAT CAN HAPPEN	◆ Exposure to sound levels of 85 dBA or above for extended periods of time can cause hearing loss.
HOW TO AVOID THE HAZARD	◆ Wear hearing protection when operating this machine.

- 1.3.3 While mowing, always wear substantial footwear and long trousers. Do not operate equipment when barefoot or when wearing open sandals.

- 1.3.4 Thoroughly inspect the area where the equipment is to be used and remove all stones, sticks, wires, bones, and other foreign objects which may damage the equipment or cause personal injury to the operator or bystanders.

 <b>WARNING</b>
<b>POTENTIAL HAZARD</b> ♦ Engine exhaust contains carbon monoxide, which is an odorless deadly poison.
<b>WHAT CAN HAPPEN</b> ♦ Carbon monoxide can kill you.
<b>HOW TO AVOID THE HAZARD</b> ♦ Do not run engine indoors or in a small confined area where dangerous carbon monoxide fumes can collect.

 <b>DANGER</b>
<b>POTENTIAL HAZARD</b> ♦ In certain conditions gasoline is extremely flammable and highly explosive.
<b>WHAT CAN HAPPEN</b> ♦ A fire or explosion from gasoline can burn you, others, and cause property damage.
<b>HOW TO AVOID THE HAZARD</b> ♦ <i>DO NOT</i> smoke while refueling, and stay away from an open flame or where gasoline fumes may be ignited by spark. ♦ Refuel only outdoors. ♦ Store gasoline in an approved container and keep it out of the reach of children. ♦ Add fuel before starting the engine. <i>Never</i> remove the cap of the fuel tank or add fuel when engine is running or when the engine is hot. ♦ Never fill the fuel tank so that the gasoline level rises above a level that is 1/2" (1.3 cm) below the bottom of the filler neck to allow for gasoline expansion and prevent fuel spillage. ♦ If fuel is spilled, <i>DO NOT</i> attempt to start the engine. Move away from the area of the spill and avoid creating any source of ignition until fuel vapors have dissipated. ♦ Do not operate without entire exhaust system in place and in proper working condition.

 **DANGER**

**POTENTIAL HAZARD**

- ◆ In certain conditions gasoline is extremely flammable and highly explosive.

**WHAT CAN HAPPEN**

- ◆ A static charge can ignite gasoline vapors. A fire or explosion from gasoline can burn you, others, and cause property damage.

**HOW TO AVOID THE HAZARD**

- ◆ Purchase and store gasoline only in an approved container.
- ◆ Always place gasoline containers on the ground away from your vehicle before filling.
- ◆ Do not fill gasoline containers inside a vehicle or on a truck or trailer bed because interior carpets or plastic truck bed liners may insulate the container and slow the loss of any static charge.
- ◆ When practical, remove gas-powered equipment from the truck or trailer and refuel the equipment with its wheels on the ground.
- ◆ If this is not possible, then refuel such equipment on a truck or trailer from a portable container, rather than from a gasoline dispenser nozzle.
- ◆ If a gasoline dispenser nozzle must be used, keep the nozzle in contact with the rim of the fuel tank or container opening at all times until fueling is complete.

 **WARNING**

**POTENTIAL HAZARD**

- ◆ Gasoline vapor can collect inside enclosed trailers and may be ignited by electrical sparks or hot engine/exhaust components.

**WHAT CAN HAPPEN**

- ◆ Explosion and fire may occur, resulting in property damage, personal injury and/or death.

**HOW TO AVOID THE HAZARD**

- ◆ Provide adequate ventilation of any enclosed trailer to prevent build up of gasoline vapors, especially at floor level.
- ◆ Refuel only outdoors, never inside an enclosed trailer.
- ◆ Be sure all fuel tanks and gasoline storage containers have proper caps installed to prevent spillage and minimize vapor escaping into the trailer.
- ◆ Do not place any equipment that is leaking gasoline in an enclosed trailer.

## 1.4 OPERATION

***Although hazard control and accident prevention are partially dependent upon the design and configuration of the equipment, these factors are also dependent upon the awareness, concern, prudence, and proper training of the personnel involved in the operation, transport, maintenance, and storage of the equipment. It is essential that all Operator Safety Mechanisms be connected and in operating condition prior to use for mowing.***



## WARNING

### POTENTIAL HAZARD

- ◆ Operating engine parts, especially the muffler, become extremely hot.

### WHAT CAN HAPPEN

- ◆ Severe burns can occur on contact.
- ◆ Debris, such as leaves, grass, brush, etc. can catch fire.

### HOW TO AVOID THE HAZARD

- ◆ Allow engine parts, especially the muffler, to cool before touching.
- ◆ Remove accumulated debris from muffler and engine area.
- ◆ Install and maintain in working order a spark arrester before using equipment on forest-covered, grass-covered, brush-covered unimproved land.

## WARNING

### POTENTIAL HAZARD

- ◆ Hands, feet, hair, clothing, or accessories can become entangled in rotating parts.

### WHAT CAN HAPPEN

- ◆ Contact with rotating parts can cause traumatic amputation or severe lacerations.

### HOW TO AVOID THE HAZARD

- ◆ Do not operate the machine without guards, shields and safety devices in place and working.
- ◆ Keep hands, feet, hair, jewelry, or clothing away from rotating parts.

- 1.4.1 Give complete, undivided attention to the job at hand.
- 1.4.2 Mow only in daylight or in good artificial light, keeping away from holes or hidden hazards. **DO NOT** operate the mower when children or others are in the area.
- 1.4.3 When feasible, avoid operating the equipment in wet grass.
- 1.4.4 Use **EXTREME** caution when mowing and/or turning on slopes as loss of traction and/or tip-over could occur. The operator is responsible for safe operation on slopes.

## DANGER

### POTENTIAL HAZARD

- ◆ Mowing on wet grass or steep slopes can cause sliding and loss of control.

### WHAT CAN HAPPEN

- ◆ Loss of control and/or loss of operator's footing could result in a fall with an arm or leg getting under the mower or engine deck, which may result in serious injury or death.

### HOW TO AVOID THE HAZARD

- ◆ Mow across slopes, never up and down.
- ◆ Do not mow slopes when grass is wet.
- ◆ Do not mow near drop-offs or near water.
- ◆ Do not mow slopes greater than 20 degrees.
- ◆ Reduce speed and use extreme caution on slopes.
- ◆ Avoid sudden turns or rapid speed changes.

- See inside the back cover to determine the approximate slope angle of the area to be mowed.
  - Progressively greater care is needed as the slope increases.
  - Always avoid sudden starting or stopping on a slope. If tires lose traction, disengage the blades and proceed slowly off the slope.
  - Be aware that loss of traction may occur going downhill. Weight transfer to the front wheels may cause drive wheels to slip and cause loss of braking and steering.
  - Watch for ditches, holes, rocks, dips, and rises that change the operating angle, as rough terrain could overturn the machine.
  - Remove or mark obstacles such as rocks, tree limbs, etc. from the mowing area. Tall grass can hide obstacles.
  - Use extreme care with grass catchers or attachments. These can change the stability of the machine and cause loss of control.
- 1.4.5 Use **EXTREME** caution when backing up. **LOOK BEHIND YOU!!**
- 1.4.6 Stop the blades when crossing surfaces other than grass, if mower must be tilted for transportation, and when transporting the mower to and from the area to be mowed.
- 1.4.7 Never operate the mower with damaged guards, shields, or covers. Always have safety shields, guards, switches, and other devices in place and in proper working condition.
- 1.4.8 **Do Not** change the engine governor settings or overspeed the engine. Operating an engine at excessive speed may increase the hazard of personal injury.
- 1.4.9 Place transmission in neutral, disengage PTO, and latch drive levers in “park brake” position before starting engine.
- 1.4.10 Start the engine carefully with feet well away from the blades.
- 1.4.11 Keep hands, feet, and clothing away from rotating parts while the mower is being operated.
- 1.4.12 Stop the engine, wait for all moving parts to stop, and remove the spark plug wire(s) and/or remove key:
- a) Before checking, cleaning, or working on the mower.
  - b) After striking a foreign object (inspect the mower for damage and make repairs before restarting and operating the mower).
  - c) Before clearing blockages.
  - d) Whenever you leave the mower.
- 1.4.13 Stop the engine and wait for all moving parts to stop:
- a) Before removing the grass catcher.
  - b) Before refueling.
  - c) Before making height adjustments.
- 1.4.14 Before stopping the engine, place the throttle control **midway** between the “slow” and “fast” positions. Allow the engine to run a minimum of 15 seconds; then stop the engine.
- 1.4.15 The fuel system is provided with a shut-off valve. The fuel shut-off valve is used to shut off the fuel when:
- a) The machine will not be used for a few days
  - b) During transport to and from the job
  - c) When parking inside a building

- 1.4.16 This mower was designed for one operator only. Keep all others away from mower during operation.
- 1.4.17 **Do Not** mow with the discharge deflector raised, removed or altered unless there is a grass collection system or mulch kit in place and working properly.
- 1.4.18 Be aware of the mower discharge and direct discharge away from others.
- 1.4.19 **Do Not** operate mower under the influence of alcohol or drugs.
- 1.4.20 Use care when approaching blind corners, shrubs, trees, or other objects that may obscure vision.

## 1.5 MAINTENANCE AND STORAGE

- 1.5.1 For engine maintenance, follow the engine manufacturer's recommendations precisely as stated in the engine manual.
- 1.5.2 Keep engine and engine area free from accumulation of grass, leaves, excessive grease or oil, and other debris which can accumulate in these areas. These materials can become combustible and may result in a fire.
- 1.5.3 Store fuel in a container specifically designed for this purpose. Store the fuel container in a cool, dry place.
- 1.5.4 Keep the mower and fuel container in locked storage to prevent children from playing or tampering with them.
- 1.5.5 Gasoline powered equipment or fuel containers should not be stored in a basement or any enclosed area where open pilot lights or heat appliances are present.
- 1.5.6 Maximum mowing results and safety can only be achieved if the mower is properly maintained and operated correctly.
- 1.5.7 Check all bolts frequently to maintain proper tightness.
- 1.5.8 Keep all guards, shields and all safety devices in place and in safe working condition.
- 1.5.9 Frequently check for worn or damaged components that could create a hazard.
- 1.5.10 All replacement parts must be the same as or equivalent to the parts supplied as original equipment.

## 1.6 RIDING ATTACHMENTS

Use only **Exmark** riding attachments. The use of other than Exmark riding attachments may create a hazardous condition resulting in injury.

## 1.7 SAFETY SIGNS

- 1.7.1 Keep all safety signs legible. Remove all grease, dirt and debris from safety signs and instructional labels.
- 1.7.2 Safety signs must be replaced if they are missing or illegible.
- 1.7.3 When new components are installed, be sure that current safety signs are affixed to the replaced components.
- 1.7.4 New safety signs may be obtained from your authorized Exmark equipment dealer or distributor or from Exmark Mfg. Co. Inc.
- 1.7.5 Safety signs can be affixed by peeling off the backing to expose the adhesive surface. Apply only to a clean, dry surface. Smooth to remove any air bubbles.
- 1.7.6 Familiarize yourself with the following safety signs and instruction labels. They are critical to the safe operation of your Exmark commercial mower.

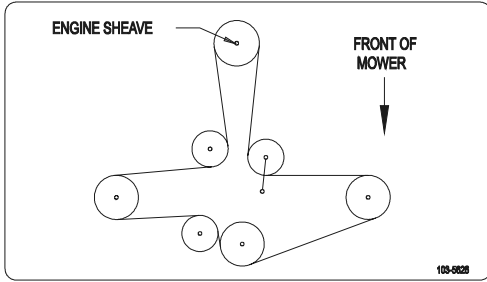

PART NO. 103-5626  
LOCATION: 48" Decks Under Belt Shield



PART NO. 103-1798  
LOCATION: RH Side of Console

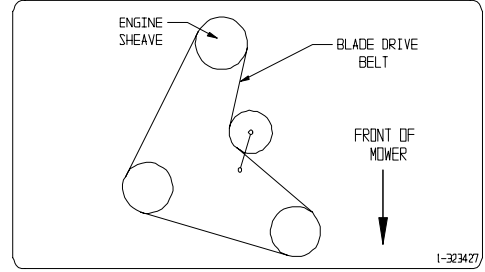

PART NO. 1-323427  
LOCATION: 32" & 36" Decks Under Belt Shield

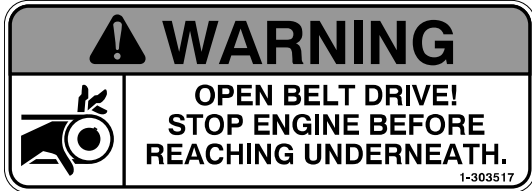

PART NO. 1-303517  
LOCATION: Left Side, Rear Surface Engine Deck



PART NO. 1-513746  
LOCATION: Engine Blower Housing Next to Muffler



PART NO. 1-403005  
LOCATION: Front Corners of Deck  
32" & 36" – RH Front  
48" – RH & LH Front

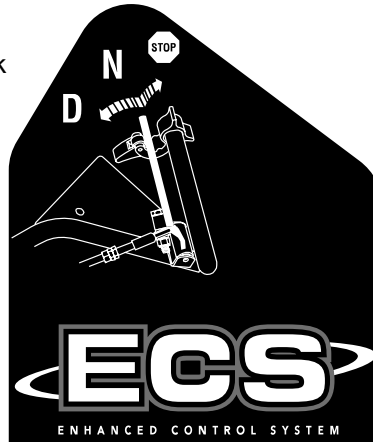

ECS Handle Units  
PART NO. 103-2244  
LOCATION: LH Side of Console



PART NO. 1-303518  
LOCATION: Transmission Shifter Plate

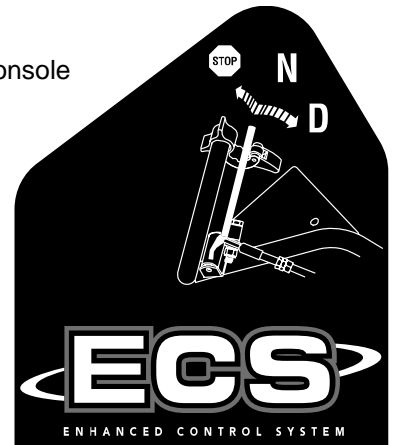

ECS Handle Units  
PART NO. 103-2245  
LOCATION: RH Side of Console

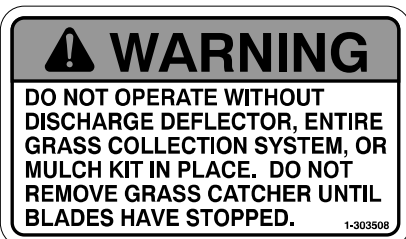

PART NO. 1-303508  
LOCATION: Right Rear Corner of Deck



PART NO. 98-5954  
LOCATION: Under Mower Deck Belt Shield

103-1623

↑ ROTATE PTO  
↓ STOP  
OFF

ON

**WARNING**

- Read operator's manual before operating.
- Do NOT operate unless trained to safely operate this machine.
- Do NOT operate without shields, guards and safety devices in place and working.
- Do NOT carry passengers.
- Clear area of debris before mowing.
- Before leaving operator's position:
  - Disengage PTO.
  - Shift transmission lever to neutral.
  - Engage park brakes.
- Shut off engine and remove key before adjusting, servicing or cleaning.
- Use extreme caution when operating on slopes.
- Do NOT operate on slopes greater than 20°.
  - Mow across slope - NOT up and down.
  - Do NOT mow wet slopes.

MAX 20°

ECS Handle Units  
PART NO. 103-1623  
LOCATION: Console

**WARNING**

Use Only Exmark Riding Attachments. Use of Other Riding Attachments May Create a Hazardous Condition Resulting in Injury. 1-403143

PART NO. 1-403143  
LOCATION: Right Rear of Engine Deck

**DANGER**

- Thrown objects or blade contact can cause serious injury or death.
- Keep all people and pets out of area when mowing.
- Avoid blades unless blades and engine are stopped.

**CAUTION**

- Hearing protection recommended.
- Do NOT park on slope unless park brake is engaged.

↑ PARK BRAKE  
● DRIVE  
↓ NEUTRAL LOCK

Pistol Grip Handle Units  
PART NO. 1-323550  
LOCATION: Upper Handles (Both Sides)

↑ ROTATE PTO  
↓ STOP

**DANGER**

- Thrown objects or blade contact can cause serious injury or death.
- Keep all people and pets out of area when mowing.
- Avoid blades unless blades and engine are stopped.

**CAUTION**

- Hearing protection recommended.
- Do NOT park on slope unless park brake is engaged.

OFF ON

**WARNING**

- Read operator's manual before operating.
- Do NOT operate unless trained to safely operate this machine.
- Do NOT operate without shields, guards and safety devices in place and working.
- Do NOT carry passengers.
- Clear area of debris before mowing.
- Before leaving operator's position:
  - Disengage PTO.
  - Shift transmission to neutral.
  - Engage park brakes.
- Shut off engine and remove key before adjusting, servicing or cleaning.
- Use extreme caution when operating on slopes.
- Mow across slope - NOT up and down.
- Do NOT operate on slopes greater than 20°.
- Do NOT mow wet slopes.

MAX 20°

103-1967

Pistol Grip Handle Units  
PART NO. 103-1967  
LOCATION: Console

## 2. SPECIFICATIONS

### 2.1 MODEL NUMBER:

M15KA322P; M15KA362P; M15KA483P; M15KA362; M15KA483

### 2.2 ENGINE

2.2.1 Engine Specifications: See your engine owner's manual.

2.2.2 RPM (No Load): 3600 rpm

### 2.3 FUEL SYSTEM

2.3.1 Capacity: 5 gal. (18.9 liter)

2.3.2 Type of Fuel: Use only clean, fresh, regular grade, unleaded gasoline with the pump sticker octane rating of 87 or higher. In countries using the research method, it should be 90 octane minimum.

2.3.3 Fuel Filter: Replaceable in-line

2.3.4 Fuel Shut Off Valve: in-line, 1/4 turn

### 2.4 SAFETY INTERLOCK SYSTEM

Operator must have the transmission in neutral and PTO disengaged to start engine. Release of Operator Presence Control (OPC) levers will cause engine to stop if *transmission is not in neutral and/or PTO is engaged.*

### 2.5 STEERING/BRAKE CONTROL

Fingertip drive control levers provide independent control of traction, braking, and neutral to each drive wheel for moving, stopping, and power turning. Parking brakes are engaged by locking drive control levers in the "brake" position.

### 2.6 TRANSMISSION

2.6.1 Peerless 700-070A, five speeds forward and one reverse.

2.6.2 Speed range:	1st	2.0 mph (3.22 km/h)	4th	4.1 mph (6.60 km/h)
	2nd	2.7 mph (4.35 km/h)	5th	6.2 mph (9.98 km/h)
	3rd	3.5 mph (5.63 km/h)	Rev	3.1 mph (4.99 km/h)

### 2.7 WHEEL DRIVE SYSTEM

Banded double A-Section V-belts, single top-side idlers and replaceable bolt-on drive sheaves and brake drums. (Single B-Section V-belts for the 32" Model)

### 2.8 TIRES

	Drive		Front Caster
	Pneumatic (Air-Filled)		Semi-Pneumatic
Deck Size	32"	36" & 48"	All Decks
Size	13 x 5.0-6	13 x 6.5-6	9 x 3.50-4
Quantity	2	2	2
Tread	Turf Saver	Turf Master	Smooth
Ply Rating	4	4	
Pressure	14 psi (97 kPa)	14 psi (97 kPa)	
Bearings	Replaceable Ball	Replaceable Ball	Replaceable Roller

### 2.9 DECK

2.9.1 Cutting Width: Model 32 ..... 31.75 in. (80.7 cm)  
Model 36 ..... 35.38 in. (89.9 cm)  
Model 48 ..... 47.25 in. (120.0 cm)

2.9.2 Discharge: Right Side

- 2.9.3 Blade Size: Model 32 ..... 16.25 (41.3 cm) - Qty. 2  
 Model 36 ..... 18.00 (45.7 cm) - Qty. 2  
 Model 48 ..... 16.25 (41.3 cm) - Qty. 3
- 2.9.4 Type of Drive: Manual engagement of belt with over-center lock. Blade belt tension is adjustable via turnbuckle.
- 2.9.5 Blade Brake: When the blade engagement control is moved to the disengaged position a friction brake pad stops the rotation of the blades.
- 2.9.6 Deck Mounting: Bolted directly to engine deck
- 2.9.7 Cutting Height: Adjusts in 1/4" (.64 cm) or smaller increments by various adjustments of caster spacers, blade spacers and axle height, from 1" to 4 1/4" (2.5 cm - 10.8 cm).

## 2.10 DIMENSIONS

2.10.1 Overall Width	32"	36"	48"
Discharge chute down	43.3 in (110.0 cm)	47.0 in (119.4 cm)	57.9 in (147.1 cm)
Discharge chute up (transport only)	32.7 in (83.1 cm)	36.4 in (92.5 cm)	48.1 in (122.2 cm)

2.10.2 Overall Length	32"	36"	48"
Standard Pistol Grip Handles	78.0 in (198.1 cm)	78.0 in (198.1 cm)	73.0 in (185.4 cm)
ECS Handles	77.3 in (196.3 cm)	77.3 in (196.3 cm)	72.3 in (183.6 cm)

2.10.3 Curb Weight*	32"	36"	48"
Standard Pistol Grip Handles	420 lbs (191 kg)	430 lbs (195 kg)	475 lbs (215 kg)
ECS Handles	435 lbs (197 kg)	446 lbs (202 kg)	490 lbs (222 kg)

\* Weights will vary slightly depending on engine option.

2.10.4 Tread Width**	32"	36"	48"
Standard Pistol Grip & ECS Handles	32.1 in (81.4 cm)	35.6 in (90.4 cm)	35.6 in (90.4 cm)

\*\* To outside of tires.

2.10.5 Overall Height	
Standard Pistol Grip Handles	40.0 in (101.6 cm)
ECS Handles	42.1 in (106.9 cm)

## 2.11 TORQUE REQUIREMENTS

<u>BOLT LOCATION</u>	<u>TORQUE</u>
Blade/Cutter Housing Spindle Bolt .....	75-80 ft-lbs. (102-109 N-m)
Caster Bracket Mounts.....	30-35 ft-lbs. (41-48 N-m)
Mower Deck/Engine Deck Mount .....	30-35 ft-lbs. (41-48 N-m)
Engine Mounting Bolts .....	15-20 ft-lbs. (20-27 N-m)
Transmission Shifter Lever Nut .....	30-35 ft-lbs. (41-48 N-m)

## 3. OPERATION INSTRUCTIONS

### 3.1 CONTROLS

- 3.1.1 Familiarize yourself with the controls and operation of the unit.  
*Carefully read the following information about the controls and their operation.*
- 3.1.2 Operator Presence Control (OPC) Levers:  
 Located on the upper handle assembly directly above the handle grips. **When these levers are depressed, the OPC system senses that the operator is in the normal operator's position. When the levers are released, the OPC system senses that the operator has moved from the normal operating position** and

will kill the engine if either the transmission shift lever is **not in the neutral** position or the **PTO is engaged**. See Figures 1 and 2.

3.1.3 Drive Levers:

Located on each side of the upper handle assembly directly below the handle grips. See Figures 1 and 2. These levers individually control clutching action of the wheel drive belts and brakes. When the drive levers are all the way down, the brakes disengage and the wheel drive belts engage.

Gradually squeezing the left or right hand drive lever disengages the wheel drive belts, causing the left hand or right hand wheel to slow down until they reach neutral or stop. This makes the machine turn to the left or right respectively. Squeezing further engages the park brakes. The sharpness of the turn varies by how much the lever is squeezed. For straight ahead motion, smoothly release both drive levers to engage both drive wheels simultaneously.

3.1.4 Neutral Lock/Park Brake Latches:

The latches allow the operator to lock the drive levers in a "neutral" position where neither the wheel drive belts nor the brakes engage or in a "park brake" position where the wheel drive belts are not engaged and the park brake is engaged. See Figures 1 and 2.

**Apply parking brakes whenever leaving the operators position.**

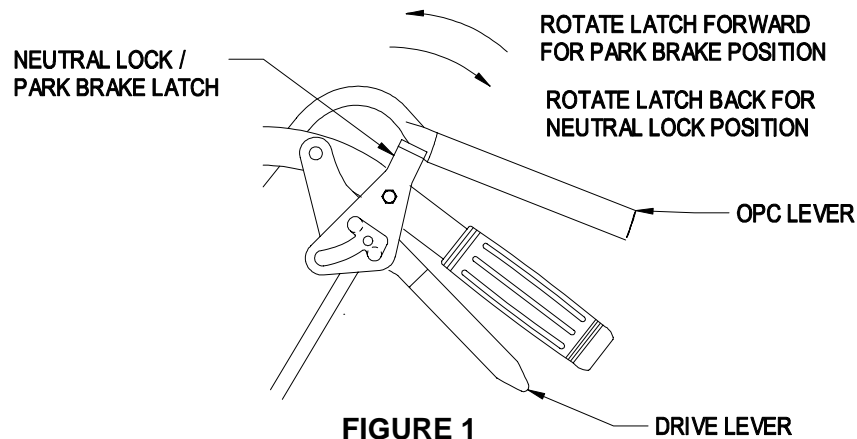

**FIGURE 1  
PISTOL GRIP HANDLE  
NEUTRAL LOCK/PARK BRAKE LATCH**

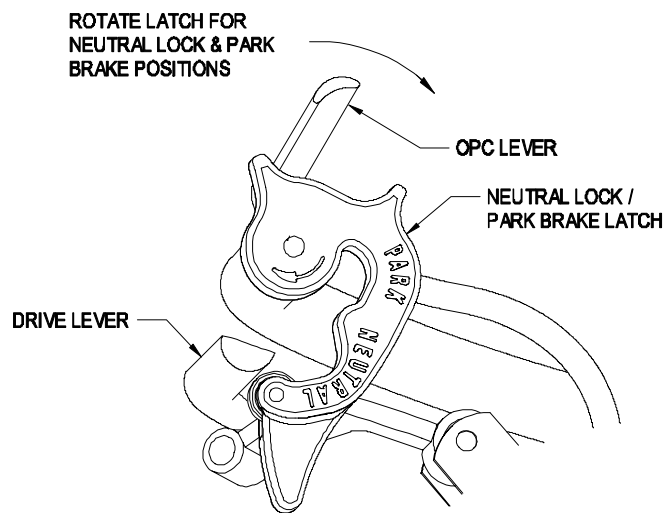

**FIGURE 2  
ECS HANDLE  
NEUTRAL LOCK/PARK BRAKE LATCH**



- 3.1.5 PTO Engagement Lever:  
Located on the left side of the upper handle.  
To engage the blades, push the lever forward, or away from the operator, until the turnbuckle locks over-center.  
To disengage the blades, pull the lever to the rear, or towards the operator.
- 3.1.6 Throttle Control:  
The throttle control is located on the control console right side. The throttle is used to control engine speed. Moving the throttle control forward will increase engine speed and moving it to the rear will decrease engine speed.
- 3.1.7 Choke Control:  
Choke aids in starting a cold engine.  
The choke control is located on the front left corner of the fuel tank support and is activated by pulling the control outward.  
Once the engine has started, move the choke control to the off position and move the throttle to the medium or full throttle position. DO NOT run the engine with the choke in the "ON" position.
- 3.1.8 "Off-Run" Switch:  
The "Off-Run" switch is located on the console. Turn the key to the "Run" position to allow the engine to be started. Turn the key to the "Off" position to shut engine off.
- 3.1.9 Transmission Shift Lever:  
Located under the control console and behind the fuel tank. It shifts the 5-speed transmission into five forward gears, neutral and reverse. Shift transmission **only** when drive levers are in the **neutral** position. Shifting without drive levers in neutral may cause damage to the transmission.  
**NOTE: Reverse is "reverse assist" only, meaning when the transmission is in reverse, the operator has to pull the unit backward to "assist" with the movement of the unit.**
- 3.1.10 Fuel Shut-Off Valve:  
Installed on the fuel line midway between the fuel tank and the engine. The fuel shut off valve shuts off the flow of fuel when the machine will not be used for a few days, when parking inside a building, and during transport to and from the job. Rotate the valve 1/4 turn clockwise to shut off fuel. Rotate the valve 1/4 turn counter-clockwise to turn on fuel.

## 3.2 PRE-START

- 3.2.1 Refer to the Maintenance Section 4.1 and perform all of the necessary inspection and maintenance steps.
- 3.2.2 Fill fuel tank. For best results, use only clean, fresh regular grade unleaded gasoline with an octane rating of 87 or higher. Regular grade leaded gasoline may also be used; however, combustion chamber and cylinder head will require more frequent service. See Engine Owner's Manual.  
*Do not* add oil to gasoline.  
**Do not** overfill fuel tank. Never fill the fuel tank so that the fuel level rises above a level that is 1/2" (1.3 cm) below the bottom of the filler neck to allow for fuel expansion and prevent fuel spillage.
- 3.2.3 Make sure you understand the controls, their locations, their functions, and their safety requirements.

### 3.3 OPERATING INSTRUCTIONS

- 3.3.1 Read the Engine Owner's Manual carefully for detailed operating instructions and maintenance regarding the engine.

Before attempting to operate the unit, refer to Section 1 (Safety) and follow all safety, operating, and preparation guidelines as stated in that section.

3.3.2 Starting Engine

Position mower on a level surface. Disengage PTO and place transmission in neutral. Open fuel shut-off valve.

**NOTE: Always engage the left and right neutral lock/park brake latches in the “park brake” position when starting the engine (See Section 3.3.4).**

Pull out the choke control. Place the throttle control midway between the “Slow” and “Fast” positions. Turn the key switch to the “Run” position.

Pull recoil rope to start engine. After the engine warms up, gradually push in the choke control. **DO NOT** run warm engine with the choke in the “ON” position.

**NOTE: Kawasaki engines generally need to be "choked" even when warm.**

3.3.3 Stopping Engine:

Lock the drive levers in “park brake” position, disengage PTO, and position transmission to neutral. Place the throttle control **midway** between the “slow” and “fast” positions. Allow the engine to run a minimum of 15 seconds and turn the key to the “Off” position.

Close fuel shut-off valve if machine will **not** be used for a few days; when parking inside a building; or when transporting the unit.

3.3.4 Drive Lever/Neutral Lock/Park Brake Latch Operation:

**For Pistol Grip Handles:** To lock the drive levers in “neutral”, squeeze the drive levers back to the neutral position. Place thumbs on the upper portion of the neutral lock/park brake latches and move them to the rear. Release the drive levers (See Figure 15).

To lock the levers in “park brake”, squeeze the drive levers back to the brake position. Place thumbs on the upper portion of the neutral lock/park brake latches and move them to the front. Release the drive levers (See Figure 3).

 <b>CAUTION</b>	
<b>POTENTIAL HAZARD</b>	◆ If the neutral lock/park brake latches are not completely engaged the drive levers could unexpectedly slip into the forward drive position.
<b>WHAT CAN HAPPEN</b>	◆ If the drive levers slip into the drive position, the unit could lurch forward and cause injury or property damage.
<b>HOW TO AVOID THE HAZARD</b>	◆ Be sure the pins protruding through the slots of each neutral lock latch are completely engaged in the rear slot of each latch.

To place the drive levers in the drive position, firmly hold the drive levers, place thumbs on the upper portion of the neutral lock/park brake latches and move them out of the “neutral” or the “park brake” position. **Slowly** and **smoothly** release the drive levers.

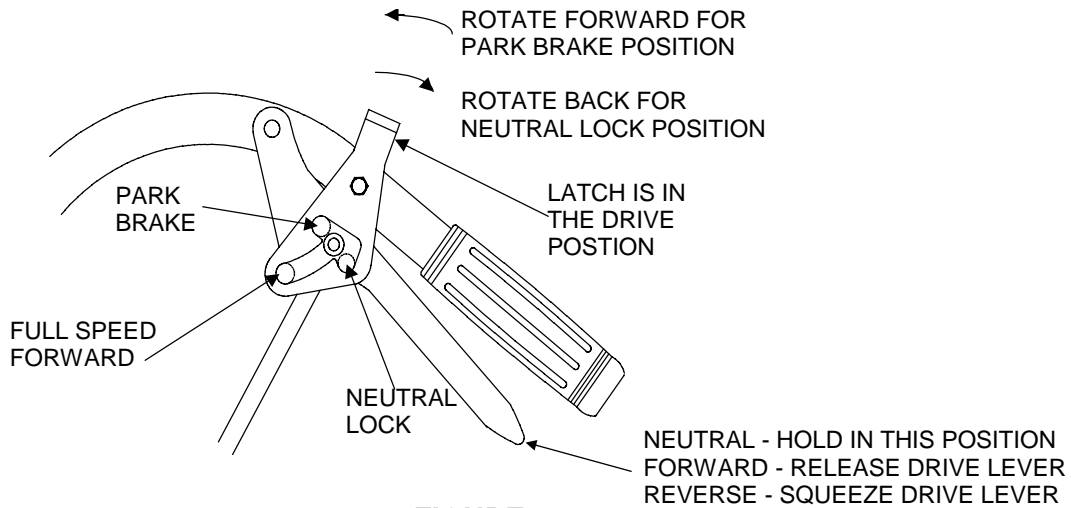

**FIGURE 3**  
**DRIVE LEVER, NEUTRAL LOCK/PARK BRAKE OPERATION**

**For ECS Handles:** To lock the drive levers in “*neutral lock*”, squeeze the drive levers to the “neutral” position. See Figure 4 (b). Place thumbs on the inner thumb lobe of the neutral lock /park brake latches and rotate them to the “neutral” position. See Figure 4 (c). Release the drive levers.

To lock the drive levers in “*park brake*”, squeeze the drive levers farther to the “brake” position. Place thumbs on the inner thumb lobe of the neutral lock/park brake latches and rotate them to the “park” position. See Figure 4 (d). Release drive levers.

 <b>CAUTION</b>	
<b>POTENTIAL HAZARD</b>	
◆ If the neutral lock/park brake latches are not completely engaged the drive levers could unexpectedly slip into the forward drive position.	
<b>WHAT CAN HAPPEN</b>	
◆ If the drive levers slip into the drive position, the unit could lurch forward and cause injury or property damage.	
<b>HOW TO AVOID THE HAZARD</b>	
◆ Be sure the drive levers are securely seated at the bottom of the “neutral” or “park” areas of the neutral lock latches.	

To place the drive levers in the “*drive*” position, slightly squeeze the drive levers while placing thumbs on the outer thumb lobe of the neutral lock/park brake latches (or the index finger on the front lobe) and rotate them from under the drive levers. **Slowly** and **carefully** release the drive levers. See Figure 4 (a).

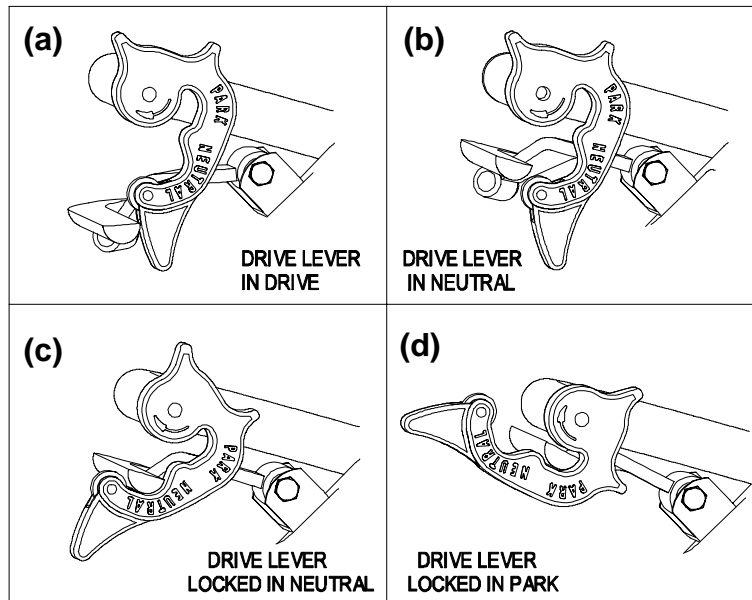

**FIGURE 4  
DRIVE LEVER, NEUTRAL LOCK/PARK BRAKE LATCH OPERATION**

**3.3.5 Drive Wheel Engagement and Turning:**

With drive levers in the “neutral” or “park brake” position, shift transmission into desired gear. Squeeze both drive levers and move both neutral lock/park brake latches from the “neutral” or “park brake” position to the “drive” position.

*For straight ahead motion:* Smoothly release both drive levers to engage drive wheels.

*For turning:* Squeeze the right hand drive lever to turn right and squeeze left hand drive lever to turn left (See Section 3.1.3).

**3.3.6 Stopping the Unit:**

Squeeze drive levers all the way back to engage brakes. Move neutral lock/park brake latches into the “park brake” position and release drive levers. Shift transmission into neutral.

**3.3.7 PTO Engagement:**

 <b>DANGER</b>	
<b>POTENTIAL HAZARD</b> <ul style="list-style-type: none"> <li>◆ The rotating blades under the mower deck are dangerous.</li> </ul>	
<b>WHAT CAN HAPPEN</b> <ul style="list-style-type: none"> <li>◆ Blade contact can cause serious injury or kill you.</li> </ul>	
<b>HOW TO AVOID THE HAZARD</b> <ul style="list-style-type: none"> <li>◆ <i>DO NOT</i> put hands or feet under the mower or mower deck when the blades are engaged.</li> </ul>	

 <b>DANGER</b>
<b>POTENTIAL HAZARD</b> <ul style="list-style-type: none"> <li>◆ An uncovered discharge opening will allow objects to be thrown in an operator's or bystander's direction. Also, contact with the blade could occur.</li> </ul>
<b>WHAT CAN HAPPEN</b> <ul style="list-style-type: none"> <li>◆ Thrown objects or blade contact can cause serious injury or death.</li> </ul>
<b>HOW TO AVOID THE HAZARD</b> <ul style="list-style-type: none"> <li>◆ Never operate the mower with the discharge deflector raised, removed, or altered unless there is a grass collection system or mulch kit in place and working properly.</li> </ul>

**Be sure that all persons are clear of mower deck and discharge area before engaging the blades.** Set throttle to "midway" (half throttle) position. Push the PTO lever forward to engage blades. Accelerate to full throttle to begin mowing. (See Section 3.1.5).

### 3.3.8 PTO Disengagement

Pull the blade engagement lever to the full rearward position to disengage the blades (See Section 3.1.5)

### 3.3.9 Changing Gears

When changing gears, **always** squeeze drive levers to the neutral position. The shift lever may be moved with a knee or by hand (engage the neutral lock latches if shifting by hand).

**NOTE: Reverse gear is reverse assist only, the operator must pull the unit backwards.**

## 3.4 TRANSPORTING

 <b>WARNING</b>
<b>POTENTIAL HAZARD</b> <ul style="list-style-type: none"> <li>◆ Loading the mower onto a trailer without strong enough or properly supported ramps could be dangerous.</li> </ul>
<b>WHAT CAN HAPPEN</b> <ul style="list-style-type: none"> <li>◆ The ramps could collapse causing the unit to fall, which could cause injury.</li> </ul>
<b>HOW TO AVOID THE HAZARD</b> <ul style="list-style-type: none"> <li>◆ Use proper ramps that are secured to the truck or trailer.</li> <li>◆ Keep feet and legs out from under the unit when loading and unloading.</li> <li>◆ If necessary, use assistance when loading.</li> </ul>

Be sure fuel shut-off valve is closed.

Use a heavy duty trailer to transport the machine. *Engage the park brakes* and block wheels. After the wheels have been properly blocked, securely fasten the machine to the trailer with straps, chains, cables, or ropes. Be sure that the trailer has all necessary lighting and marking as required by law and use a safety chain.

**NOTE: When transporting machine, be sure to engage the park brakes. Failure to do so can result in damage and/or premature wear to drive train.**

***Do not rely solely on the parking brake to hold machine on trailer.***

## 4. MAINTENANCE AND ADJUSTMENTS

### 4.1 PERIODIC MAINTENANCE

 <b>WARNING</b>
<b>POTENTIAL HAZARD</b> <ul style="list-style-type: none"><li>◆ While maintenance or adjustments are being made, someone could start the engine.</li></ul>
<b>WHAT CAN HAPPEN</b> <ul style="list-style-type: none"><li>◆ Accidental starting of the engine could seriously injure you or other bystanders.</li></ul>
<b>HOW TO AVOID THE HAZARD</b> <ul style="list-style-type: none"><li>◆ Remove the key from the ignition switch and/or pull the wire(s) off the spark plug(s) before you do any maintenance. Also push the wire(s) aside so it does not accidentally contact the spark plug(s).</li></ul>

 <b>WARNING</b>
<b>POTENTIAL HAZARD</b> <ul style="list-style-type: none"><li>◆ The engine can become very hot.</li></ul>
<b>WHAT CAN HAPPEN</b> <ul style="list-style-type: none"><li>◆ Touching a hot engine can cause severe burns.</li></ul>
<b>HOW TO AVOID THE HAZARD</b> <ul style="list-style-type: none"><li>◆ Allow the engine to cool completely before service or making repairs around the engine area.</li></ul>

#### 4.1.1 Check engine oil level.

##### **Service Interval: See Engine Owner's Manual**

- Stop engine and wait for all moving parts to stop. Make sure machine is on a level surface.
- Check with engine cold.
- Clean area around dipstick. Remove dip stick and wipe off oil. Reinsert the dipstick (**Do not** screw into place).  
Remove dipstick and check oil level.
- If the oil level is low, add oil as specified in the engine owners manual to bring the oil level up to the "FULL" mark on the dipstick. **DO NOT OVERFILL.**  
**IMPORTANT: Do Not operate the engine with oil level below the "LOW" (or "ADD") mark on the dipstick or over the "FULL" mark.**

#### 4.1.2 Clean engine air cooling system.

##### **Service Interval: See Engine Owner's Manual**

- Stop engine and wait for all moving parts to stop. Remove key or spark plug wire(s).
- Clean all debris from engine air intake screen and from around engine shrouding.

4.1.3 Clean grass build-up under deck and check mower blades.

**Service Interval: Daily**

 <b>CAUTION</b>	
<b>POTENTIAL HAZARD</b>	◆ Raising the mower deck for service or maintenance relying solely on mechanical or hydraulic jacks could be dangerous.
<b>WHAT CAN HAPPEN</b>	◆ The mechanical or hydraulic jacks may not be enough support or may malfunction allowing the unit to fall, which could cause injury.
<b>HOW TO AVOID THE HAZARD</b>	◆ <b>DO NOT</b> rely solely on mechanical or hydraulic jacks for support. Use adequate jack stands or equivalent support.

- a) Disengage PTO.
- b) Stop engine and wait for all moving parts to stop. Remove key or spark plug wire(s).
- c) Raise deck, support properly using safety precautions.
- d) Clean out any grass build-up from underside of deck and in deck discharge chute.
- e) Inspect blades and sharpen or replace as required.
- f) If blade removal is necessary, be careful for the sharp cutting edges of the blades.
- g) Re-install the blades (if they were removed) and torque blade bolts to 75-85 ft/lbs (102-115 N-m). Be sure the spring disk washer cone is installed toward the bolt head (See Figure 5).
- h) Remove jack stands (or equivalent support) and lower deck to ground.

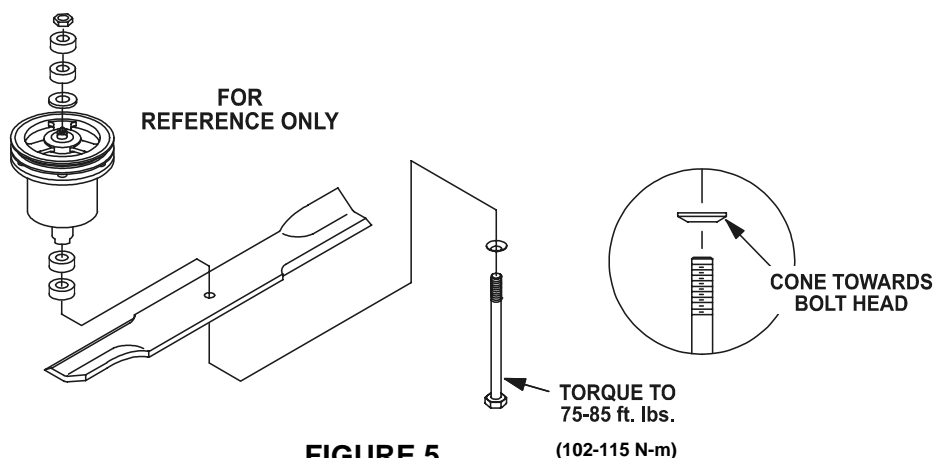

**FIGURE 5**  
**BLADE BOLT INSTALLATION**

4.1.4 Check safety interlock system.

**Service Interval: Daily**

- a) For your safety, your Exmark mower is equipped with Operator Presence Controls, referred to as (OPC). When either the PTO is engaged, or the transmission shifter lever is not in neutral and the operator removes both hands from the handles, the mower engine **MUST stop**.
- b) To determine if the OPC is in operating condition, clear area of bystanders. Run the engine at one-third throttle, then with the drive levers and neutral lock latches in the “**park brake**” position, shift the transmission into gear and release the OPC levers – **the engine MUST stop**.

Again, run the engine at one-third throttle, move the transmission shifter lever to neutral, engage the PTO and release the OPC levers - **the engine MUST stop.**

**If the mower engine does not stop under any of the above mentioned conditions, DO NOT OPERATE. Contact your authorized Exmark service dealer.**

**IMPORTANT: It is essential that all Operator Safety Mechanisms, be in place and in proper operating condition prior to mowing.**

4.1.5 Check Brake and Wheel Drive Linkage Adjustment.

**Service Interval: Daily**

- a) Check for correct brake adjustment:

Place the drive levers in the **“park brake”** position. The mower **should not** move forward or backward. If it does, tighten the wingnuts.

Place the drive levers in the **“neutral lock”** position. The mower **should** move forward and backward freely. If it does not, brake adjustment is necessary.

- b) Adjust brakes by adjusting wingnut on the upper end of each brake rod. Tighten the wingnut until the brakes engage when the drive levers are squeezed enough to allow the neutral lock/park brake latches to be placed into the “park brake” position.

See Figure 3 for Standard Pistol Grip handles and Figure 4 for ECS handles.

**NOTE: The neutral lock/park brake latches must be able to be moved into the park brake position, if not, the brake linkages must be adjusted again.**

- c) Check for correct wheel drive linkage adjustment:

**For Pistol Grip Handles:**

Allow drive levers to drop into the full forward position: The clevis pin should rest in the neutral lock latch with approximately 3/16” to 1/4” (4.7 – 6.4 mm) clearance from the bottom of the slot (See Figure 6). Adjust if necessary.

To adjust the wheel drive linkage:

- d) For wheel drive linkage adjustment, remove the hairpin between the neutral lock latch and drive lever (See Figure 6).

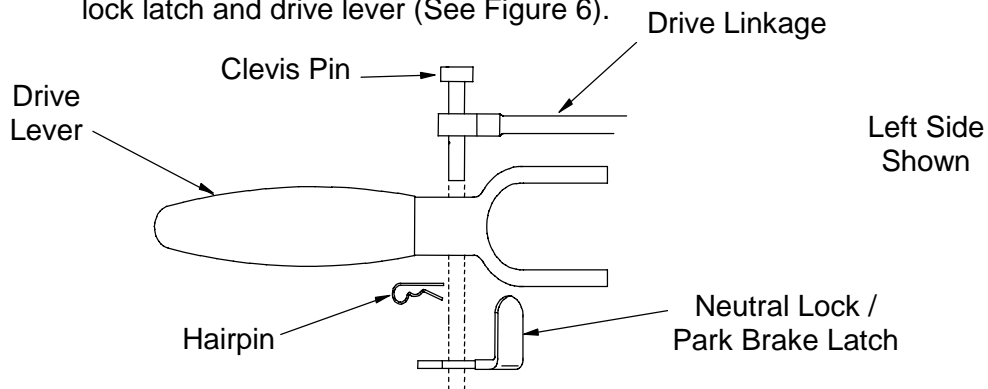

**FIGURE 6  
PISTOL GRIP HANDLES  
DRIVE LEVER HARDWARE LOCATION**

- e) Adjust drive linkage length by threading into or out of the swivel until there is a 3/16” to 1/4” (.47-.64 cm) clearance between the linkage assembly and the bottom of the slot in the neutral lock/park brake latch (See Figure 7).



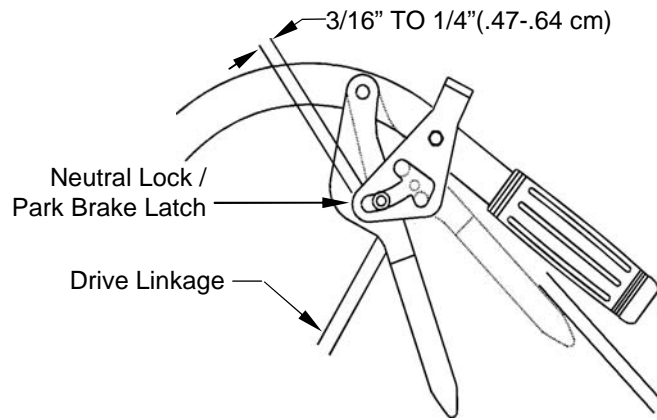

**FIGURE 7  
PISTOL GRIP HANDLES  
NEUTRAL LOCK LEVER CLEARANCE**

**NOTE:** Neutral lock/park brake latch clearance should be checked when there is a slight upward force placed on the drive levers to remove any "slack" in the linkage.

- f) Re-install hairpin into hole on the clevis pin **between** the neutral lock/park brake latch and drive lever (See Figure 6). Repeat procedure on opposite side of unit.

***For ECS Handles:***

Allow drive levers to drop into the full forward position: the flat edge of the drive lever should align with the bottom roller notch (See Figure 8). Adjust if necessary.

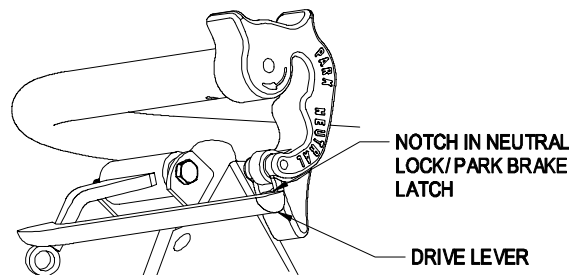

**FIGURE 8  
ECS HANDLE DRIVE LEVER SETTING**

To adjust the wheel drive linkage linkage:

- d) Locate a drive lever linkage on one side of the unit and remove the 5/16-18 x 1 3/4 Hex cap screw and 5/16-18 nyloc nut (See Figure 9).
- e) Thread drive lever linkage into or out of the swivel located on the wheel drive idler arm until the flat edge of the drive lever aligns with bottom of the roller notch in the neutral lock/park brake latch (See Figure 9).
- f) Re-install the 5/16-18 x 1 3/4 hex cap screw and secure with the 5/16-18 nyloc nut. Repeat for the other side (See Figures 9).

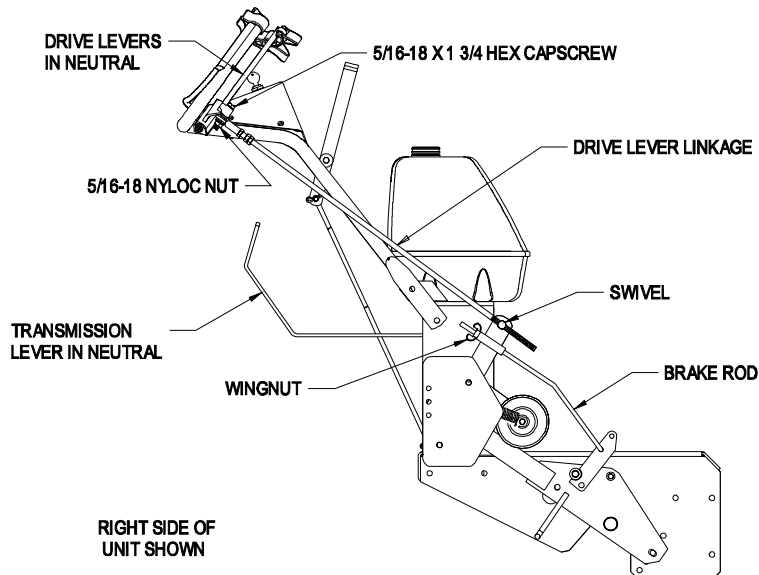

**FIGURE 9**  
**ECS HANDLE DRIVE LEVER LINKAGE INSTALLATION**

4.1.6 Check for loose hardware.

**Service Interval: Daily**

- a) Stop engine and wait for all moving parts to stop. Remove key or spark plug wire(s).
- b) Visually inspect machine for any loose hardware or any other possible problem. Tighten or replace any hardware before operating.

4.1.7 Service pre-cleaner element and air cleaner.

**Service Interval: See Engine Owners Manual**

- a) Stop engine and wait for all moving parts to stop. Remove key or spark plug wire(s).
- b) See engine owners manual for cleaning instructions.

4.1.8 Change engine oil.

**Service Interval: See Engine Owner's Manual**

**NOTE: Change oil after first five (5) hrs. of operation. Follow engine manufacturer's recommendations for future oil changes.**

- a) Disengage PTO.
- b) Stop engine and wait for all moving parts to stop. Remove key or spark plug wire(s).
- c) Drain oil while engine is **warm** from operation or if oil is to be changed after the unit has been sitting for awhile, run engine for a few minutes to get it warm.
- d) Remove the oil drain plug from the right hand side of the engine. Allow oil to drain, replace drain plug.
- e) Replace the oil filter per the engine owners manual. Clean around oil filter and unscrew filter to remove. Before the new filter is installed, apply a thin coating of oil on the surface of the rubber seal. Turn filter clockwise until rubber seal contacts the filter adapter, then tighten filter an additional 2/3 to 3/4 turn.
- f) Clean around oil fill cap and remove. Fill to specified capacity and replace cap. Refer to Engine Owner's Manual for correct oil level and the SAE Grade recommended by the manufacturer. **Do Not overfill.**
- g) Start the engine and check for leaks. Stop engine and recheck oil levels.

4.1.9 Check tire pressures.

**Service Interval: Pneumatic (air-filled) Drive Tires- 40 hrs.**

**Semi-pneumatic Caster Tires – No maintenance**

- a) Stop engine and wait for all moving parts to stop. Remove spark plug wire(s). Check air pressure in drive tires; recommended tire pressure is: 12 to 16 psi (83-110 kPa).
- b) Inflate tires to pressures stated above. Measure the circumference of each drive tire. Adjust tire pressures within the above range to try to make tire circumferences match as closely as possible.

4.1.10 Check grease level, input and output shaft bearing wear on Peerless Transmission. (Replace gearbox grease yearly)

**Service Interval: 160 hrs.**

- a) Stop engine and wait for all moving parts to stop. Remove key or spark plug wire(s).
- b) Place drive levers and neutral lock/park brake latches in neutral lock position.
- c) Remove shifter lever from top of transmission.
- d) Remove shifter plate from top of transmission and the two leads from the neutral start switch.
- e) Release the tension on the transmission belt.
- f) Check for side play caused by bearing wear on the input and output shafts of the transmission. Replace bearings if necessary.
- g) Remove the six bolts that fasten the upper case to the lower case and carefully remove the upper case half.
- h) Check the grease level in the lower case. The grease level should be approximately 1-1/2" to 1-3/4" (3.8 to 4.4 cm) from the gearbox bottom. If necessary, fill to proper level with Peerless grease (Part No. 788067).
- i) Reinstall upper case half and fasten in place with six bolts previously removed.
- j) Reinstall all parts removed in Steps c and d. Install drive belt and adjust tension as stated in Section 4.2.3.

4.1.11 Inspect belt wear.

**Service Interval: 40 hrs.**

- a) Stop engine and wait for all moving parts to stop. Remove key or spark plug wire(s).
- b) Remove the mower deck belt shield to check mower blade drive belt condition.
- c) Look under engine deck to check the transmission drive belt condition.
- d) Inspect wheel drive belt conditions.
- e) Check all idler arms to be sure they pivot freely. Disassemble, clean and grease pivot bushings if necessary.

4.1.12 Lubrication:

**Service Interval: Refer to Chart**

- a) Stop engine and wait for all moving parts to stop. Remove key or spark plug wire(s).
- b) Lubricate fittings with one to two pumps of SAE No. 2 multi-purpose gun grease. Refer to the following chart for fitting locations and lubrication schedule.

## LUBRICATION CHART

FITTING LOCATIONS	INITIAL PUMPS	FITTING QUANTITY			SERVICE INTERVAL
		32"	36"	48"	
1. Caster Wheel Bearings	12	2	2	2	Daily
2. Caster Pivots	2	2	2	2	Daily
3. Drive Wheels	18	2	2	2	Daily
4. Drive Wheel Idler Arm	2	2	2	2	Daily
5. Brake Arm	2	2	2	2	Weekly
6. Trans. Output Shaft Coupler	2	2	2	2	Weekly
7. Mower Deck Idler Pivots	2	1	1	1	Weekly

No.6 (Trans. Coupler)  
Located Below  
Fuel Tank Support

No. 4 & 7 (Idler Arm Pivots)  
Disassemble and grease once a  
Month under a "No Load" condition

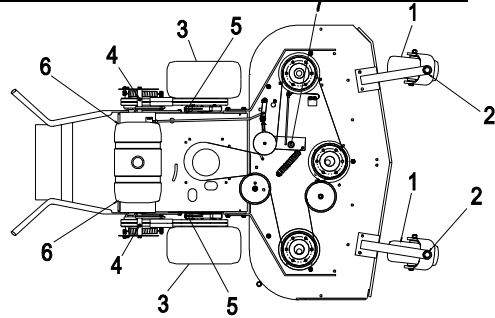

48" Deck Shown for Reference Only

- c) Replace 5-speed gearbox grease yearly. Use 18 oz. of Peerless grease (Part No. 788067). See Section 5.1.10.
- d) Lubricate pivot points with a spray penetrating lubricant as directed below.

### SPRAY LUBRICANT CHART

PIVOT POINTS	NO. of PLACES			SERVICE INTERVAL
	32"	36"	48"	
1. Blade Engagement Bellcrank	1	1	1	Weekly

#### 4.1.13 Remove engine shrouds and clean cooling fins.

**Service Interval: See Engine Owner's Manual**

- a) Stop engine and wait for all moving parts to stop. Remove key or spark plug wire(s).
- b) Remove cooling shrouds from engine and clean cooling fins. Also clean dust, dirt and oil from external surfaces of engine that can cause improper cooling.
- c) Make sure cooling shrouds are properly reinstalled. Operating the engine without cooling shrouds will cause engine damage due to overheating.

#### 4.1.14 Check spark plugs.

**Service Interval: See Engine Owner's Manual**

Remove spark plug, check condition and adjust plug gap, or replace with new plug (See Engine Owner's Manual).

#### 4.1.15 Change fuel filter.

**Service Interval: As Required**

A fuel filter is installed in the fuel line between the fuel tank and the engine. Replace when necessary.

#### 4.1.16 Engine maintenance.

**Service Interval: See Engine Owner's Manual**

Refer to the Engine Owner's Manual regarding maintenance required for the engine.

#### 4.1.17 Check all safety signs for visibility. Replace as needed.

4.1.18 Thread locking adhesives Fel-Pro Pro-Lock "Nut-Type" or Loctite Threadlocker "242" are used on the following:

- a) All belt drive pulley setscrews.
- b) OPC lever setscrews.
- c) Pulley retaining bolt in end of engine crankshaft.
- d) Fuel tank bulkhead fitting threads.

Adhesives such as Loctite "RC/609" or "RC/680" or Fel-Pro Pro-Lock "Retaining" or "Retaining II" are used on the following:

- a) OPC lever hubs and cross-shaft.

**NOTE: When applying any locking adhesives, care must be used not to bond the bearing (next to each OPC hub) to the cross-shaft. This could cause binding of the OPC levers and erratic operation.**

- b) Fuel tank studs, where studs are inserted into tank.

4.1.19 An anti-seize compound is used on the following locations:

- a) Between the blade drive and transmission drive pulleys and engine crankshaft.
- b) Between the transmission drive pulley and transmission drive shaft.
- c) Between the bearings and sheaves and transmission output shafts.

4.1.20 Mobil HTS grease (or food-grade antisieze) is used in the following locations:

- a) Between the cutter housing spindle and bearings.
- b) Between the cutter housing spindle and sheave.

4.1.21 Dielectric grease is used on all blade type electrical connections to prevent corrosion and loss of contact.

## 4.2 ADJUSTMENTS

4.2.1 Adjusting cutting height with blade spacers.

Blades may be adjusted for cutting height by using the four 1/4" (.64 cm) spacers found on the blade spindle bolts (factory setting is two above and two below). This allows a 1" (2.5 cm) range in 1/4" (.64 cm) increments of cutting height in any axle position. The same number of blade spacers must be used on all blades to achieve a level cut (two above and two below, one above and three below, etc.).

For the best cut and discharge, place a minimum of two spacers between the blade and spindle shaft.

For the highest quality cut, place all four spacers between the blade and the spindle shaft.

If the mulching kit is installed, the highest quality cut can be obtained with 3 spacers between the blade and spindle (minimum is 1 for a good cut).

If you need to cut higher or lower than what the spacers will allow, it will be necessary to adjust the rear axle height and caster position. See Section 4.2.2 below.

4.2.2 Axle height and caster position.

Desired cutting height range can be obtained by adjusting the rear axle and placing caster spacers above or below the caster arm (See Figures 10 and 11 along with the Cutting Height Adjustment Chart). **It may be necessary to readjust wheel drive and brake linkages.**

To adjust rear axle:

- a) Stop engine and wait for all moving parts to stop. Remove key or spark plug wire(s).
- b) Place the drive levers in the neutral lock position.
- c) Remove mower deck belt shield for access to axle adjustment bolts.

- d) Loosen but do not remove the two (2) axle pivot bolts and the two (2) axle adjustment bolts (See Figure 11).
- e) Place a jack under the rear center of the engine deck.
- f) Raise the back end of the engine deck up enough to remove the two (2) axle adjustment bolts.
- g) With the jack, raise or lower the back end of the engine deck so that two (2) axle adjustment bolts can be reinstalled in desired hole location. A tapered punch can be used to help align the holes.
- h) Retighten all four (4) bolts, lower unit and remove jack.
- i) Install mower deck belt shield.
- j) Adjust wheel drive and brake linkages as required. (See Section 4.1.5).
- k) Adjust the caster spacers as directed in chart to match with the axle hole selected. (See Figure 10).
- l) Refer back to 4.2.1 for adjusting the cutting height with blade spacers.

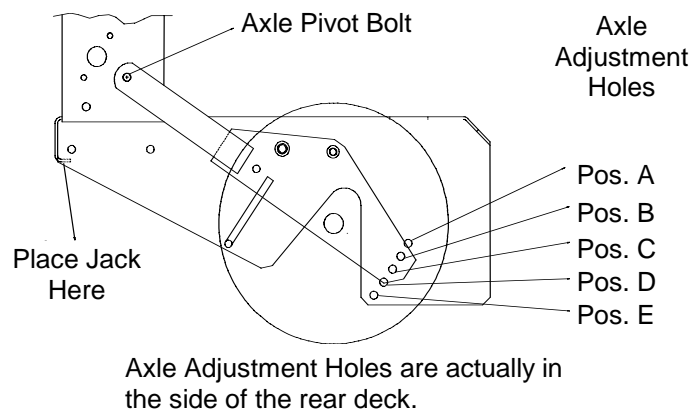
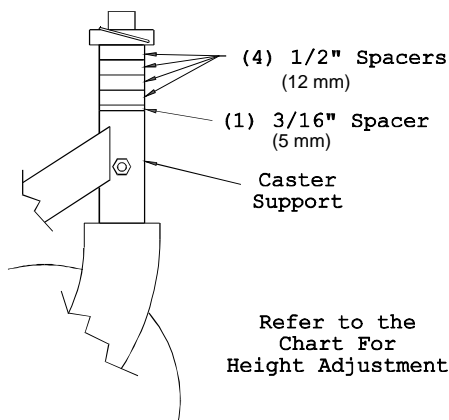

**FIGURE 10**  
**CASTER HEIGHT ADJUSTMENT**

**FIGURE 11**  
**AXLE HEIGHT ADJUSTMENT**

These models have five (5) axle positions; four (4) 1/2" (1.3 cm) caster spacers; one (1) 3/16" (.47 cm) caster spacer, and four (4) blade spacers.

**NOTE: The axle positions are in 1/2" (1.3 cm) increments and the large caster spacers are 1/2" (1.3 cm) thick. Therefore, by adjusting the same number of 1/2" (1.3 cm) caster spacers as axle hole positions the blades will retain the same front-to-back tip (rake).**

## CUTTING HEIGHT ADJUSTMENT (1" to 4 1/4")

AXLE POSITION (FIG. 20)	# OF SPACERS BELOW CASTER SUPPORT HUB		NUMBER OF 1/4" BLADE SPACERS BELOW SPINDLE				
	1/2"	3/16"	4	3	2	1	0
	A	0	0	1" (2.5 cm)	1 1/4" (3.2 cm)	1 1/2" (3.5cm)	1 3/4" (4.4cm)
A	0	1	1 1/8" (2.9 cm)	1 3/8" (3.5 cm)	1 5/8" (4.1 cm)	1 7/8" (4.8 cm)	2 1/8" (5.4 cm)
A	1	0	1 3/8" (3.5 cm)	1 5/8" (4.1cm)	1 7/8" (4.8 cm)	2 1/8" (5.4 cm)	2 3/8" (6.0 cm)
B	0	1	1 3/8" (3.5 cm)	1 5/8" (4.1cm)	1 7/8" (4.8 cm)	2 1/8" (5.4 cm)	2 3/8" (6.0 cm)
B	1	0	1 5/8" (4.1 cm)	1 7/8" (4.8 cm)	2 1/8" (5.4 cm)	2 3/8" (6.0 cm)	2 5/8" (6.7 cm)
B	1	1	1 3/4" (4.4 cm)	2" (5.0 cm)	2 1/4" (5.7 cm)	2 1/2" (6.4 cm)	2 3/4" (7.0 cm)
B	2	0	2" (5.0 cm)	2 1/4" (5.7 cm)	2 1/2" (6.4 cm)	2 3/4" (7.0 cm)	3" (7.6 cm)
C	1	1	1 7/8" (4.8 cm)	2 1/8" (5.4 cm)	2 3/8" (6.0 cm)	2 5/8" (6.7 cm)	2 7/8" (7.3 cm)
C	2	0	2 1/8" (5.4 cm)	2 3/8" (6.0 cm)	2 5/8" (6.7 cm)	2 7/8" (7.3 cm)	3 1/8" (7.9 cm)
C	2	1	2 1/4" (5.7 cm)	2 1/2" (6.4 cm)	2 3/4" (7.0 cm)	3" (7.6 cm)	3 1/4" (8.3 cm)
C	3	0	2 1/2" (6.4 cm)	2 3/4" (7.0 cm)	3" (7.6 cm)	3 1/4" (8.3 cm)	3 1/2" (8.9 cm)
D	2	1	2 3/8" (6.0 cm)	2 5/8" (6.7 cm)	2 7/8" (7.3 cm)	3 1/8" (7.9 cm)	3 3/8" (8.6 cm)
D	3	0	2 1/2" (6.4 cm)	2 3/4" (7.0 cm)	3" (7.6 cm)	3 1/4" (8.3 cm)	3 1/2" (8.9 cm)
D	3	1	2 3/4" (7.0 cm)	3" (7.6 cm)	3 1/4" (8.3 cm)	3 1/2" (8.9 cm)	3 3/4" (9.5 cm)
D	4	0	3" (7.6 cm)	3 1/4" (8.3 cm)	3 1/2" (8.9 cm)	3 3/4" (9.5 cm)	4" (10.1 cm)
E	3	1	2 7/8" (7.3 cm)	3 1/8" (7.9 cm)	3 3/8" (8.6 cm)	3 5/8" (9.2 cm)	3 7/8" (9.8 cm)
E	4	0	3 1/8" (7.9 cm)	3 3/8" (8.6 cm)	3 5/8" (9.2 cm)	3 7/8" (9.8 cm)	4 1/8" (10.5cm)
E	4	1	3 1/4" (8.3 cm)	3 1/2" (8.9 cm)	3 3/4" (9.5 cm)	4" (10.1 cm)	4 1/4" (10.8cm)

**IMPORTANT: To achieve the highest quality of cut, the blades should be level with the ground, or tipped slightly down at the front.**

### 4.2.3 Transmission belt adjustment.

- a) Stop engine and wait for all moving parts to stop. Remove key or spark plug wire(s).
- b) To tighten transmission belt, loosen the 3/8" nyloc nut on transmission belt idler pulley. Slide bolt inward in slot and retighten nyloc nut.
- c) When properly adjusted, the belt should have 1/2" (1.3 cm) of deflection with three pounds of pressure on the belt midway between the transmission and engine pulley.

### 4.2.4 Wheel drive belt pulley scrapers.

- a) Stop engine and wait for all moving parts to stop. Remove key or spark plug wire(s).
- b) Be sure mud and grass scraper, on each side, is adjusted properly and centered in the pulley grooves. The pointed part of the scraper should be centered and as deep in the pulley groove as possible without rubbing at any point.

### 4.2.5 Engine to mower deck belt.

- a) Stop engine and wait for all moving parts to stop. Remove key or spark plug wire(s).
- b) Check the adjustment of the lower blade drive linkage located between the bellcrank on the engine deck and assist arm on the mower deck. Lengthen or shorten the linkage. When properly adjusted, there should be 1/16" to 1/8" (2 – 3 mm) of clearance between bell-crank and transmission output shaft when belt is engaged. Make sure the assist arm is against the rear assist arm stop on the deck (See Figure 21). Push the lever down to the disengaged position. The assist arm should contact the front assist arm stop on the deck. If it does not contact, readjust so that the bellcrank is closer to the transmission output shaft.

- c) Belt must be tight enough to not slip during heavy loads while cutting grass. Overtensioning will reduce belt and spindle bearing life. To adjust belt tension, loosen the 5/16" whizlock nut on turnbuckle and rotate the turnbuckle; rotate turnbuckle toward rear of mower to tighten, and toward front of mower to loosen belt tension (See Figure 12). Leave a minimum of 5/16" (.79 cm) of the eyebolt threads engaged on both ends of the turnbuckle.

**For 48" Decks:** If there is no adjustment left in the turnbuckle and the belt is still loose, the rear idler pulley can be repositioned in the front hole (See Figure 12). The belt guide located next to the pulley must also be repositioned in the front hole when the pulley is moved. The turnbuckle will need to be readjusted.

Check belt tension after the first hour of operation and at least twice during the first 24 hours of operation. Adjust as necessary.

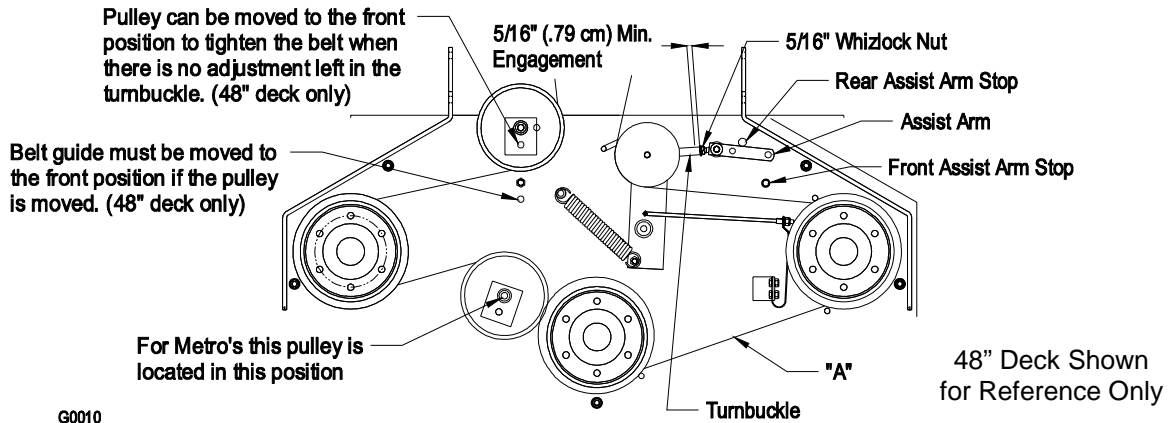

**FIGURE 12  
MOWER DECK BELT ADJUSTMENT**

- d) Proper belt tension will require about 10 lbs. side pull on belt, halfway between pulleys (See Figure 12, Point A) to deflect belt 1/2" (12 mm).
- e) Check belt guide under the engine deck to see that it is properly set. (See Section 3.2.7). Also check the blade brake adjustment. (See Section 3.2.6)

#### 4.2.6 Blade Brake Adjustment:

- Stop engine and wait for all moving parts to stop. Remove key or spark plug wire(s).
- Disengage blades.
- Make sure the blade brake pad rests against the sheave. Adjust the spring mounting bolts to properly align the pad on the sheave (See Figure 13).
- Check the distance between the spacer and the nut at the end of the blade brake rod. The distance should be between 1/8" and 3/16" (3 – 5 mm) (See figure 13).
- Engage the blade control and check to make sure the blade brake pad clears the sheave.



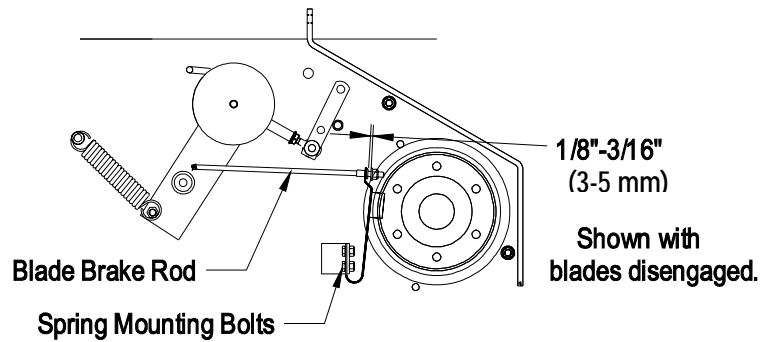
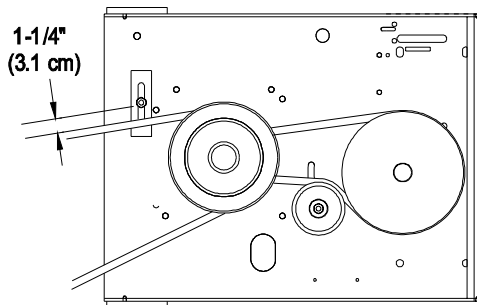

**FIGURE 13  
BLADE BRAKE ADJUSTMENT**

4.2.7 Belt Guide Adjustment

- a) Stop engine and wait for all moving parts to stop. Remove key or spark plug wire(s).
- b) Engage the blade drive belt.
- c) Check belt guide under the engine deck for proper adjustment (See Figures 14 and 15). Adjust as necessary.

The disengaged belt should not drag or fall off pulley when guides are properly adjusted.



**NOTE: These drawings are viewed from underneath the engine deck.  
FIGURE 14**

**32" & 36" BELT GUIDE LOCATION**

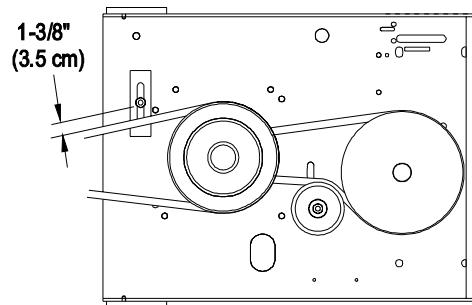

**FIGURE 15**

**48" BELT GUIDE LOCATION**

4.2.8 Brake adjustment - See Section 4.1.5.

4.2.9 Wheel drive linkage adjustment - See Section 4.1.5.

4.2.10 Shifter lever adjustment

The shifter lever in neutral should not contact the upper or lower edge of the slot or the left edge of the upper slot or the right edge of the bottom slot (See Figure 16 and 17). The clearance should be equal. Adjust the shifter lever and shifter plate if necessary.

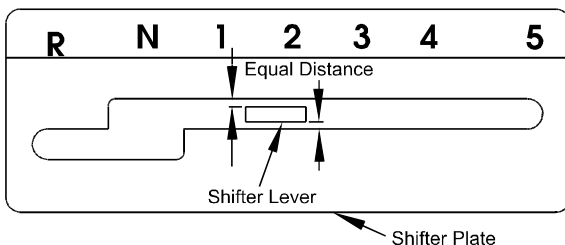

**FIGURE 16**

**SHIFTER LEVER CLEARANCE**

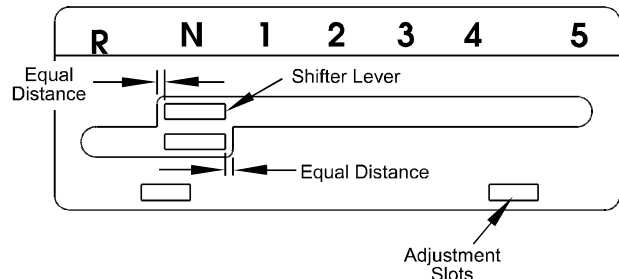
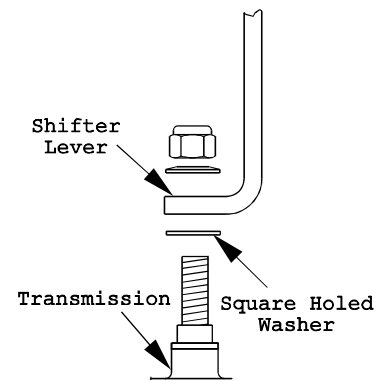

**FIGURE 17**

To adjust the shifter lever:

- a) Remove the 3/8" nyloc nut and spring disk washer from the stud on top of the transmission (See Figure 18).
- b) Remove the shifter lever and bend it slightly. **DO NOT** bend the lever while it is attached to the transmission.
- c) Re-install lever and torque the 3/8" nyloc nut to 35 ft.-lbs. (47 N-m).

**NOTE:** The square-hole washer must be between the lever and the transmission.



**FIGURE 18  
SHIFTER LEVER  
TO TRANSMISSION**

To adjust shifter plate:

- a) Place shifter lever in the neutral position. Loosen the two bolts securing the shifter plate to the shifter lever legs. Adjust shifter plate and retighten bolts.

- 4.2.11 Shifter detent adjustment - Transmission shifter detent can be adjusted by adjusting the setscrew on the back side of transmission located just behind the neutral start switch. Turn setscrew in (clockwise) to hold the transmission shifter more positively in each gear and to increase the force on the lever required to shift gears.

Turn setscrew out (counterclockwise) to decrease force on lever required to shift gears. Factory setting is to turn setscrew all the way in then back out 1-1/2 turns.

**IMPORTANT: Screwing setscrew in too far will prevent the transmission from shifting.**

- 4.2.12 PTO safety switch adjustment.

- a) Stop engine and wait for all moving parts to stop. Remove key or spark plug wire(s).
- b) With the blades disengaged and the bellcrank touching the engine deck, adjust the blade safety switch (if needed) until the bellcrank depresses the plunger by 1/4" (.64 cm).
- c) Be sure the bellcrank does not contact the switch body to prevent damage to the switch.
- d) Retighten switch mounting hardware.

- 4.2.13 Handle height adjustment.

The handle can be pivoted to allow positioning in one of the three holes allowing various adjustments for operator comfort (See Figure 19).

To adjust the handle height:

- a) Remove the bottom mounting hardware on each side of the handle.
- b) Pivot the handle to one of the three positions.
- c) Re-install hardware and tighten.

**IMPORTANT: If the handle height position is changed, it will be necessary to readjust the drive and brake linkage (See Section 4.1.5).**

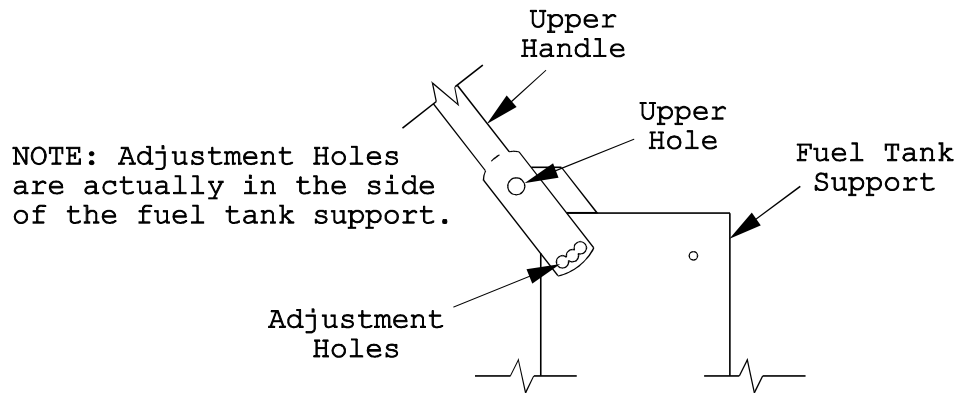

**FIGURE 19  
UPPER HANDLE HEIGHT ADJUSTMENT**

**4.2.14 Wheel drive spring tension adjustment.**

It may be necessary to increase wheel drive belt tension under certain operating conditions such as, wet grass, hilly terrain, or while pulling a sulky.

- a) Stop engine and wait for all moving parts to stop. Remove key or spark plug wire(s).
- b) Disengage neutral lock/park brake latches and release drive levers to lower spring force.
- c) Remove the 5/16-18 whizlock nut securing the adjustment bolt to the drive wheel shield. Locate bolt assembly in the desired position as follows:
  - Position A - Normal Conditions
  - Position B - More Severe
  - Position C - Most Severe

**NOTE: Lever force is lowest with bolt assembly in Position A and will increase in Positions B and C (See Figure 20).**

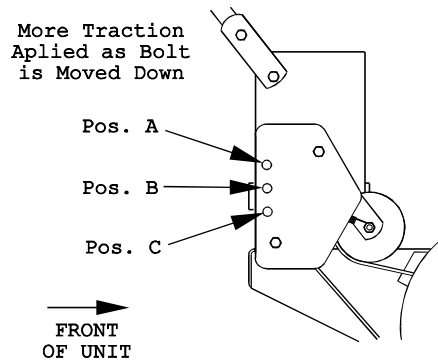

**FIGURE 20  
DRIVE BELT TENSION  
ADJUSTMENT POSITIONS**

**5. WASTE DISPOSAL**

**5.1 MOTOR OIL DISPOSAL**

Engine oil is a pollutant to the environment. Dispose of used oil at a certified recycling center or according to your state and local regulations.

**6. TROUBLE SHOOTING**

**6.1 MOWER PULLING LEFT OR RIGHT.**

- a) Check idler arm pulleys and drive sheaves for mud and/or grass buildup. Check for proper scraper position. See Section 4.2.4.

- b) Check to be sure idler arms pivot freely, if not, lubricate idler pivots.
- c) Check for worn drive belts.

**NOTE: Wheel drive belts should be replaced as a set. A new belt should not be mixed with a worn belt.**

- d) Check drive linkage adjustment - See Section 4.1.5.
- e) Check for proper tire pressure in drive tires. Recommended tire pressure for the drive tires is 12 to 16 psi (82 –110 kPa). Higher pressures may be used in the tire on the side that it pulls to (up to 28 psi or 193 kPa).

**Note:** *Different pressures may make mower cut unevenly.*

## **6.2 MOWER CUTS UNEVENLY.**

- a) Check the drive tire pressure and tire circumference. See Section 4.1.9.  
A more uniform cutting height may be obtained with higher tire pressure on rough terrain. A lower tire pressure provides more flotation.
- b) Check blade spacers, axle positions, and front caster spacers. They must be equal on each blade.
- c) Check caster mounting brackets to be sure all bolts are tight.
- d) Check blades tip to tip for straightness. (They should be within 3/16" (.47 cm) or one blade width from being in line.)

## **6.3 BLADES DO NOT STOP WHEN DISENGAGED.**

- a) Check the blade brake adjustment. (See Section 4.2.6)
- b) Check the belt guide under the rear deck to make it is properly set (See Section 5.2.7) and check the PTO engagement adjustment. (See Section 4.2.5)

## **6.4 ENGINE WILL NOT START.**

- a) Refer to Section 4.3.2 and follow directions to make sure engine is being properly choked.
- b) Make sure transmission is in "true neutral" position. See Sections 3.12 (c).
- c) Check that the PTO is disengaged and the PTO switch is depressed (See Section 4.2.12).
- d) Check that there is fuel in the tank and that the fuel valve is open.
- e) Check that the spark plug wire(s) is/are properly connected.
- f) Check for loose or faulty wiring connections.
- g) Check for corrosion at all wiring connections. Even minor corrosion may cause a faulty connection. Clean connector terminals thoroughly, apply dielectric grease and reconnect.
- h) For Kawasaki: Check that the key switch is in the "Run" position.

**NOTE: After carefully checking the previous steps, attempt to start the engine. If it does not start, contact your authorized Exmark service dealer.**

## **ENGINE TROUBLESHOOTING**

When a problem occurs, do not overlook the simple causes. For example, starting problems could be caused by an empty fuel tank, key switch not "ON" etc. The following tables list some common causes of troubles. Do not attempt to service or replace major items or any items that call for special timing or adjustment procedures (governor, valves, etc.). Have this work done by your Engine Service Dealer.

## ENGINE TROUBLESHOOTING TABLE

PROBLEM	NO FUEL	IMPROPER FUEL	DIRT IN FUEL	DIRTY AIR FILTER	FAULTY SPARK PLUG	ENGINE OVER-LOADED	BLOCKED FUEL FILTER	INCORRECT OIL LEVEL	DIRTY AIR SCREEN
Will not start	X		X	X	X	X	X		
Hard starting	X	X	X	X	X	X	X		
Stops suddenly	X		X	X		X	X	X	X
Lacks power		X	X	X	X	X	X	X	X
Operates erratically		X	X	X	X	X	X		X
Knocks or pings		X		X		X			X
Skips or misfires		X	X	X	X				X
Backfires			X	X	X	X			
Overheats			X	X		X		X	X
High fuel consumption				X	X	X			X

### 7. MOWER DECK BELT ROUTING

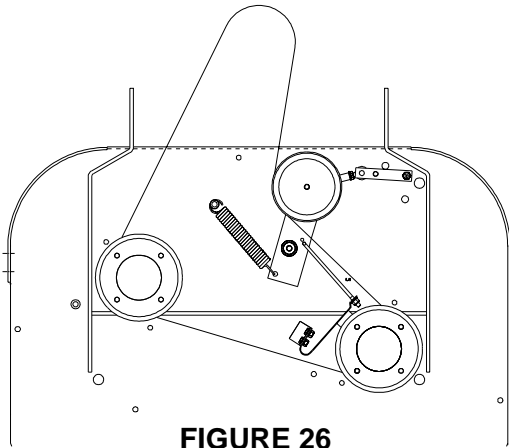

**FIGURE 26**  
32" and 36" MOWER DECK

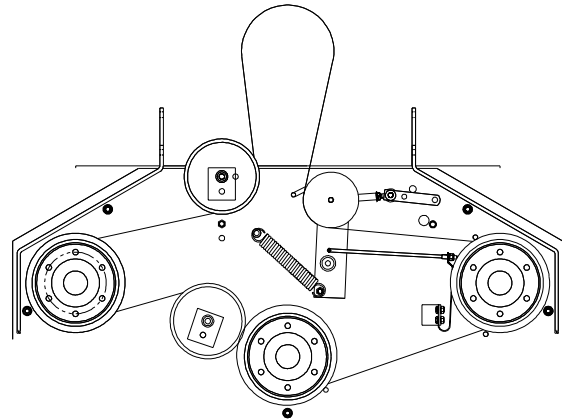

**FIGURE 27**  
48" MOWER DECK

### 8. WIRING DIAGRAM

#### KAWASAKI

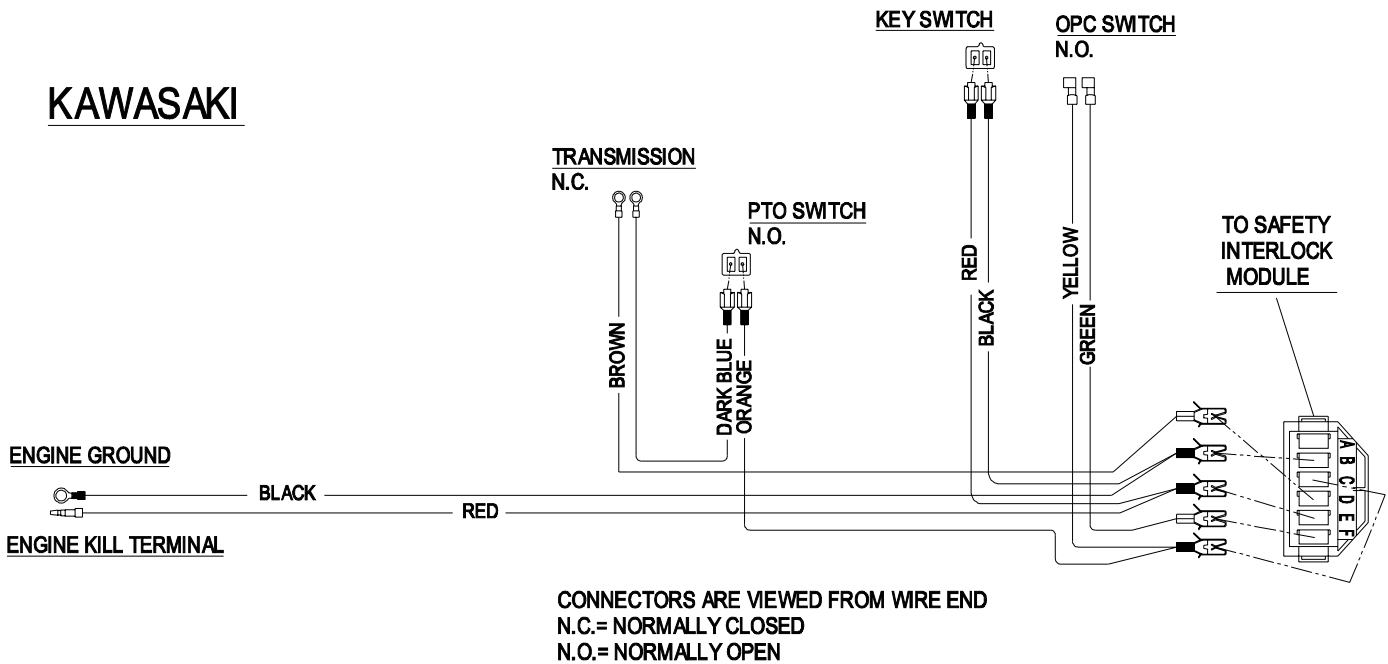

9.

**2-Year Limited Warranty  
Exmark Turf Equipment**

(For units purchased on or after October 1, 2004)

**Conditions and Products Covered**

Exmark Mfg. Co. Inc. and its affiliate, Exmark Warranty Company, pursuant to an agreement between them, jointly warrant on the terms and conditions herein, that we will repair, replace or adjust any part manufactured by Exmark and found by us (in the exercise of our reasonable discretion) to be defective in factory materials or workmanship for a period of two years.

This warranty applies to Exmark turf equipment purchased on or after October 1, 2004 sold in the US or Canada. This warranty may only be assigned or transferred to a second (or third) owner by an authorized Exmark dealer. The warranty period commences upon the date of the original retail purchase.

<u>Products</u>	<u>Warranty Period</u>
• All Products (except as noted below)	2 years
• All Attachments and Accessories	1 year
• Metro 21 and Metro 26 Series	1 year
• Belts and Tires	90 days
• Battery	1 Year Prorated
• Engine*	Warranty is covered by engine manufacturer

\*Please refer to the engine manufacturer's warranty statement that is included in the literature packet. We are not authorized to handle warranty adjustments on engines.

This warranty only includes the cost of parts and labor.

**Items and Conditions Not Covered**

This warranty does not cover the following:

- Pickup and delivery charges to and from any authorized Exmark Service Dealer.
- Any damage or deterioration due to normal use, wear and tear, or exposure.
- Cost of regular maintenance service or parts, such as filters, fuel, lubricants, tune-up parts, and adjustments.
- Any product or part which has been altered or misused or required replacement or repair due to normal wear, accidents, or lack of proper maintenance.
- Any repairs necessary due to use of parts, accessories or supplies, including gasoline, oil or lubricants, incompatible with the turf equipment or other than as recommended in the operator's manual or other operational instructions provided by Exmark.

All warranty work must be performed by an authorized Exmark Service Dealer using Exmark approved replacement parts.

**Instructions for Obtaining Warranty Service**

1. Contact any Exmark Service Dealer to arrange service at their dealership. To locate a dealer convenient to you, access our website at [www.exmark.com](http://www.exmark.com). U.S. Customers may also call 402-223-6375.
2. Bring the product and your proof of purchase (sales receipt) to the Exmark Service Dealer.

If for any reason you are dissatisfied with the Service Dealer's analysis or with the assistance provided, contact us at:

Exmark Customer Service Department  
 The Exmark Warranty Company  
 2101 Ashland Avenue  
 Beatrice, NE 68310  
 402-223-6375 or  
[service@exmark.com](mailto:service@exmark.com)

**Owner's Responsibilities**

The Exmark turf equipment, including any defective part, must be returned to an authorized Exmark service dealer within the warranty period. This warranty extends only to turf equipment operated under normal conditions. You must properly service and maintain your Exmark product as described in the operator's manual. Such routine maintenance, whether performed by a dealer or by you, is at your expense.

As a condition to this warranty, customer shall have read the operator's manual and shall have completed and submitted to Exmark Warranty Company, within the prescribed time, the Exmark warranty registration.

**General Conditions**

The sole liability of Exmark and Exmark Warranty Company with respect to this warranty shall be repair and replacement as set forth herein. **Neither Exmark nor Exmark Warranty Company shall have any liability for any other cost, loss or damage, including but not limited to, any incidental or consequential loss or damage.**

In particular, we shall have no liability or responsibility for:

- Expenses related to gasoline, oil or lubricants.
- Travel time, overtime, after hours time or other extraordinary repair charges or charge relating to repairs or replacements outside of normal business hours at the place of business of the authorized Exmark service dealer.
- Rental of like or similar replacement equipment during the period of any warranty, repair or replacement work.
- Any telephone or telegram charges or travel charges.
- Loss or damage to person or property other than that covered by the terms of this warranty.
- Any claims for lost revenue, lost profit or additional cost as a result of a claim of breach of warranty.
- Attorney's fees.

No Claim of breach of warranty shall be cause for cancellation or rescission of the contract of sale of any Exmark mower.

There are no understandings, agreements, representations, or warranties, express or implied, including but not limited to any regarding the merchantability (that product is fit for ordinary use) or fitness for use (that product is fit for a particular purpose), not specified herein, respecting the equipment which is the subject of this warranty.

**Some states do not allow exclusions of incidental or consequential damages, or limitations on how long an implied warranty lasts, so the above exclusions and limitations may not apply to you.**

This warranty gives you specific legal rights, and you may also have other rights which vary from state to state.

**10. Evaporative Emission Control Warranty Statement**  
California Evaporative Emission Control Warranty Statement  
Your Warranty Rights and Obligations

**Introduction**

The California Air Resources Board and Exmark Manufacturing Company are pleased to explain the evaporative emission control system's warranty on your 2006 model year equipment. In California, new equipment that uses small off-road engines must be designed, built, and equipped to meet the State's stringent anti-smog standards. Exmark Manufacturing Company must warrant the evaporative emission control system on your equipment for two years provided there has been no abuse, neglect or improper maintenance of your equipment.

Your evaporative emission control system may include parts such as: fuel lines, fuel line fittings, and clamps.

**Manufacturer's Warranty Coverage:**

This evaporative emission control system is warranted for two years. If any evaporative emission-related part on your equipment is defective, the part will be repaired or replaced by Exmark Manufacturing Company.

**Owner's Warranty Responsibilities:**

- As the equipment owner, you are responsible for performance of the required maintenance listed in your Operator's Manual. Exmark Manufacturing Company recommends that you retain all receipts covering maintenance on your equipment, but Exmark Manufacturing Company cannot deny warranty solely for the lack of receipts.
- As the equipment owner, you should however be aware that Exmark Manufacturing Company may deny you warranty coverage if your emission warranty parts have failed due to abuse, neglect, or improper maintenance or unapproved modifications.
- You are responsible for presenting your equipment to an Authorized Service Dealer as soon as the problem exists. The warranty repairs should be completed in a reasonable amount of time, not to exceed 30 days. If you have a question regarding your warranty coverage, you should contact Exmark Manufacturing Company at 1-402-223-6375.

**Defects Warranty Requirements:**

1. The warranty period begins on the date the engine or equipment is delivered to an ultimate purchaser.
2. General Evaporative Emissions Warranty Coverage. The emission warranty parts must be warranted to the ultimate purchaser and any subsequent owner that the evaporative emission control system when installed was:
  - A. Designed, built, and equipped so as to conform with all applicable regulations; and
  - B. Free from defects in materials and workmanship that causes the failure of a warranted part for a period of two years.
3. The warranty on evaporative emissions-related parts will be interpreted as follows:
  - A. Any warranted part that is not scheduled for replacement as required maintenance in the written instructions must be warranted for the warranty period of two years. If any such part fails during the period of warranty coverage, it must be repaired or replaced by Exmark Manufacturing Company. Any such part repaired or replaced under the warranty must be warranted for a time not less than the remaining warranty period.
  - B. Any warranted part that is scheduled only for regular inspection in the written instructions must be warranted for the warranty period of two years. A statement in such written instructions to the effect of "repair or replace as necessary" will not reduce the period of warranty coverage. Any such part repaired or replaced under warranty must be warranted for a time not less than the remaining warranty period.
  - C. Any warranted part that is scheduled for replacement as required maintenance in the written instructions must be warranted for the period of time prior to the first scheduled replacement point for that part. If the part fails prior to the first scheduled replacement, the part must be repaired or replaced by Exmark Manufacturing Company. Any such part repaired or replaced under warranty must be warranted for a time not less than the remainder of the period prior to the first scheduled replacement point for the part.
  - D. Repair or replacement of any warranted part under the warranty provisions of this article must be performed at no charge to the owner at an Authorized Service Dealer.
  - E. Notwithstanding the provisions of subsection (D) above, warranty services or repairs must be provided at an Authorized Service Dealer.
  - F. The owner must not be charged for diagnostic labor that leads to the determination that a warranted part is in fact defective, provided that such diagnostic work is performed at an Authorized Service Dealer.
  - G. Throughout the evaporative emission control system's two year warranty period, Exmark Manufacturing Company must maintain a supply of warranted parts sufficient to meet the expected demand for such parts.
  - H. Manufacturer approved replacement parts must be used in the performance of any warranty maintenance or repairs and must be provided without charge to the owner. Such use will not reduce the warranty obligations of Exmark Manufacturing Company.
  - I. The use of any add-on or modified parts will be grounds for disallowing a warranty claim made in accordance with this article. Exmark Manufacturing Company will not be liable under this Article to warrant failures of warranted parts caused by the use of an add-on or modified part.
  - J. Exmark Manufacturing Company shall provide any documents that describe the warranty procedures or policies within five working days of request by the Air Resources Board.

**Emission Warranty Parts List:**

The following list includes the parts covered under this warranty:

- Fuel Lines
- Fuel Line Fittings
- Clamps

## NOTES



## NOTES



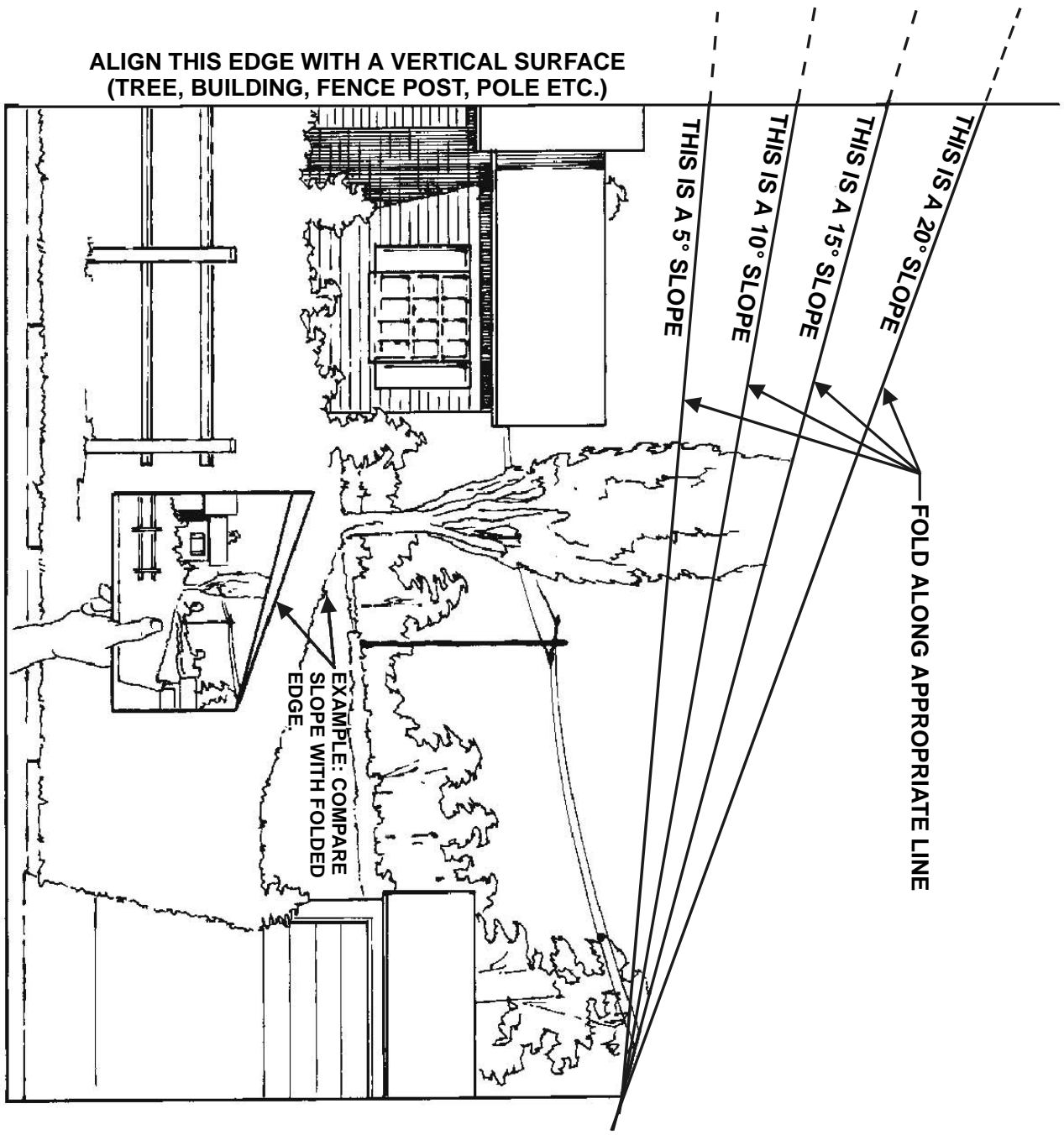

# SEE EXMARK'S COMPLETE LINE OF ACCESSORIES

## RIDING ACCESSORIES

CUSTOM RIDE SEAT SUSPENSION SYSTEM  
DECK LIFT ASSIST KIT  
HITCH KIT  
LIGHT KIT  
MICRO-MULCH SYSTEM  
ROLL OVER PROTECTION SYSTEM (ROPS)  
SNOW BLADE  
SUN SHADE  
TRASH CONTAINER  
TURF STRIPER  
ULTRA VAC COLLECTION SYSTEM  
ULTRA VAC QUICK DISPOSAL SYSTEM

## WALK BEHIND ACCESSORIES

GRASS CATCHER  
MICRO-MULCH SYSTEM  
STEERABLE SULKY  
SULKY HITCH KIT  
TURF STRIPER  
STANDON

Check us out on the Web:

**[www.exmark.com](http://www.exmark.com)**

### **WARNING**

The engine exhaust from this product contains chemicals known to the State of California to cause cancer, birth defects, or other reproductive harm.

©1997-2005 EXMARK MFG. CO. INC.  
INDUSTRIAL PARK BOX 808  
BEATRICE, NE 68310

ALL RIGHTS RESERVED

PART NO. 103-9911 Rev. A  
(402) 223-6300  
FAX (402) 223-5489

PRINTED IN U.S.A.

