

# COMMERCIAL 21

**For Serial Nos.  
850,000 & Higher**  
Part No. 4500-674 Rev. A

# Operator's Manual

## **⚠️ WARNING**

### **CALIFORNIA Proposition 65 Warning**

The engine exhaust from this product contains chemicals known to the State of California to cause cancer, birth defects, or other reproductive harm.

**Important:** The engine in this product is not equipped with a spark arrester muffler. It is a violation of California Public Resource Code (CPRC) Section 4442 to use or operate this engine on any forest-covered, brush-covered, or grass-covered land as defined in CPRC 4126. Other states or federal areas may have similar laws.

To acquire a spark arrester for your unit, see your Engine Service Dealer.

This spark ignition system complies with Canadian ICES-002 Ce système d'allumage par étincelle de véhicule est conforme à la norme NMB-002 du Canada.

The enclosed Engine Owner's Manual is supplied for information regarding The U.S. Environmental Protection Agency (EPA) and the California Emission Control Regulation of emission systems, maintenance and warranty.

Keep this engine Owner's Manual with your unit. Should this engine Owner's Manual become damaged or illegible, replace immediately. Replacements may be ordered through the engine manufacturer.

Exmark reserves the right to make changes or add improvements to its products at any time without incurring any obligation to make such changes to products manufactured previously. Exmark, or its distributors and dealers, accept no responsibility for variations which may be evident in the actual specifications of its products and the statements and descriptions contained in this publication.



If your Exmark dealer does not have the Exmark part in stock, Exmark will get the parts to the dealer the next business day or the part will be FREE Guaranteed!! (Some restrictions apply. See your participating Exmark Dealer for details.)

# Introduction

**CONGRATULATIONS** on the purchase of your Exmark Mower. This product has been carefully designed and manufactured to give you a maximum amount of dependability and years of trouble-free operation.

This manual contains operating, maintenance, adjustment, and safety instructions for your Exmark mower.

**BEFORE OPERATING YOUR MOWER, CAREFULLY READ THIS MANUAL IN ITS ENTIRETY.**

By following the operating, maintenance, and safety instructions, you will prolong the life of your mower, maintain its maximum efficiency, and promote safe operation.

If additional information is needed, or should you require trained mechanic service, contact your authorized Exmark equipment dealer or distributor. Exmark parts manuals are available online at <http://www.exmark.com/manuals.htm>.

All Exmark equipment dealers and distributors are kept informed of the latest methods of servicing and are equipped to provide prompt and efficient service in the field or at their service stations. They carry ample stock of service parts or can secure them promptly for you from the factory.

All Exmark parts are thoroughly tested and inspected before leaving the factory, however, attention is required on your part if you are to obtain the fullest measure of satisfaction and performance.

Whenever you need service, genuine Exmark parts, or additional information, contact an Authorized Service Dealer or Exmark Customer Service and have the model and serial numbers of your product ready.

Figure 1 identifies the location of the model and serial numbers on the product. Write the numbers in the space provided.

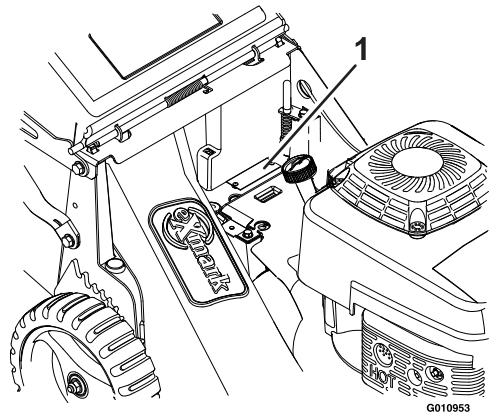

**Figure 1**

1. Model and serial number location

<b>Model No.</b> _____
<b>Serial No.</b> _____

# Contents

Introduction .....	3	Cleaning Under the Belt Cover (Self-Propelled Units Only).....	33
Safety .....	5	Cleaning the Blade Brake Clutch Shield (Blade Brake Clutch Units Only) .....	33
Safety Alert Symbol.....	5	Cleaning Under the Cover Plate (Non-Blade Brake Clutch Units Only).....	33
Safe Operating Practices .....	5	Waste Disposal.....	34
Safety and Instructional Decals .....	9	Storage .....	35
Specifications .....	12	Preparing the Fuel System.....	35
Model Numbers .....	12	Preparing the Engine.....	35
Systems .....	12	General Storage Information.....	35
Dimensions.....	12	Removing the Lawn Mower from Storage.....	35
Product Overview .....	13	Troubleshooting .....	36
Operation .....	13		
Controls.....	13		
Pre-Start.....	15		
Operating Instructions .....	15		
Maintenance .....	22		
Recommended Maintenance Schedule(s) .....	22		
Periodic Maintenance .....	23		
Check Engine Oil Level.....	23		
Checking the Blade Brake Clutch (Blade Brake Clutch Only).....	23		
Check the Mower Blade.....	24		
Check for Loose Hardware.....	25		
Check the Blade Brake Clutch Bail Operation (Blade Brake Clutch Units Only).....	25		
Service Air Filter (Kawasaki Units).....	26		
Service Air Filter (EC21ASHN Units).....	26		
Service Air Filter (EC21HNBBC and EC21HNBBCX Units).....	27		
Change Engine Oil.....	28		
Change Oil Filter (EC21KA, EC21KABBC, EC21KAX, EC21KAY, EC21KABBCX, EC21KABBCY, EC21KACA, and EC21KABBCCA) .....	29		
Check Condition Of Belt (Self-Propelled Units Only) .....	29		
Check Spark Plugs.....	29		
Emptying the Fuel Tank and Cleaning the Fuel Filter.....	29		
Adjustments .....	30		
Adjusting the Self-Propel Drive (Self-Propelled Units Only).....	30		
Adjusting the Blade Brake Cable (Blade Brake Clutch Units Only).....	31		
Cleaning .....	32		
Clean Grass Build-Up Under Deck .....	32		
Cleaning the Discharge Tunnel and Plug.....	32		

# Safety

## Safety Alert Symbol

This lawn mower meets or exceeds the Consumer Product Safety Commission blade safety requirements for walk-behind rotary mowers and the B71.4 specifications of the American National Standards Institute in effect at the time of production.

Exmark designed and tested this lawn mower to offer reasonably safe service; however, failure to comply with the following instructions may result in personal injury.

This Safety Alert Symbol (Figure 2) is used both in this manual and on the machine to identify important safety messages which must be followed to avoid accidents.

This symbol means: **ATTENTION! BECOME ALERT! YOUR SAFETY IS INVOLVED!**



Figure 2

1. Safety alert symbol

The safety alert symbol appears above information which alerts you to unsafe actions or situations and will be followed by the word **DANGER**, **WARNING**, or **CAUTION**.

**DANGER:** White lettering / Red background. Indicates an imminently hazardous situation which, if not avoided, **Will** result in death or serious injury.

**WARNING:** Black lettering / Orange background. Indicates a potentially hazardous situation which, if not avoided, **Could** result in death or serious injury.

**CAUTION:** Black lettering / Yellow background. Indicates a potentially hazardous situation which, if not avoided, **May** result in minor or moderate injury.

This manual uses two other words to highlight information. **Important** calls attention to special mechanical information and **Note** emphasizes general information worthy of special attention.

## Safe Operating Practices

### Training

- Read the Operator's Manual and other training material. If the operator(s) or mechanic(s) can not read English it is the owner's responsibility to explain this material to them.
- Become familiar with the safe operation of the equipment, operator controls, and safety signs.
- All operators and mechanics should be trained. The owner is responsible for training the users.
- Never let children or untrained people operate or service the equipment. Local regulations may restrict the age of the operator.
- Only adults and mature teenagers should operate a mower, and even mature teenagers should have adult supervision. Be sure a teenager:
  1. has read and understands the Operator's Manual and recognizes the risks involved;
  2. is sufficiently mature to use caution; and
  3. is of sufficient size and weight to operate the controls comfortably and to manage the mower without taking risks.
- The owner/user can prevent and is responsible for accidents or injuries occurring to himself or herself, other people or property.

### Preparation

- Evaluate the terrain to determine what accessories and attachments are needed to properly and safely perform the job. Only use accessories and attachments approved by Exmark.
- Wear appropriate clothing including safety glasses, substantial footwear, long trousers, and hearing protection. Do Not operate when barefoot or when wearing open sandals. Long hair, loose clothing or jewelry may get tangled in moving parts.

### **CAUTION**

**This machine produces sound levels in excess of 85 dBA at the operator's ear and can cause hearing loss through extended periods of exposure.**

**Wear hearing protection when operating this machine.**

# Safety

- Inspect the area where the equipment is to be used and remove all rocks, toys, sticks, wires, bones, and other foreign objects which can be thrown by the machine and may cause personal injury to the operator or bystanders.

## **⚠ DANGER**

In certain conditions gasoline is extremely flammable and vapors are explosive.

A fire or explosion from gasoline can burn you, others, and cause property damage.

- Fill the fuel tank outdoors in an open area, when the engine is cold. Wipe up any gasoline that spills.
- Never refill the fuel tank or drain the machine indoors or inside an enclosed trailer.
- Do Not fill the fuel tank completely full. Add gasoline to the fuel tank until the level is 1/4 to 1/2 inch (6–13 mm) below the bottom of the filler neck. This empty space in the tank allows gasoline to expand.
- Never smoke when handling gasoline, and stay away from an open flame or where gasoline fumes may be ignited by spark.
- Store gasoline in an approved container and keep it out of the reach of children.
- Add fuel before starting the engine. Never remove the cap of the fuel tank or add fuel when engine is running or when the engine is hot.
- If fuel is spilled, Do Not attempt to start the engine. Move away from the area of the spill and avoid creating any source of ignition until fuel vapors have dissipated.
- Do Not operate without entire exhaust system in place and in proper working condition.

## **⚠ DANGER**

In certain conditions during fueling, static electricity can be released causing a spark which can ignite gasoline vapors. A fire or explosion from gasoline can burn you and others and cause property damage.

- Always place gasoline containers on the ground away from your vehicle before filling.
- Do Not fill gasoline containers inside a vehicle or on a truck or trailer bed because interior carpets or plastic truck bed liners may insulate the container and slow the loss of any static charge.
- When practical, remove gas-powered equipment from the truck or trailer and refuel the equipment with its wheels on the ground.
- If this is not possible, then refuel such equipment on a truck or trailer from a portable container, rather than from a gasoline dispenser nozzle.
- If a gasoline dispenser nozzle must be used, keep the nozzle in contact with the rim of the fuel tank or container opening at all times until fueling is complete.

## **⚠ WARNING**

Gasoline is harmful or fatal if swallowed. Long-term exposure to vapors has caused cancer in laboratory animals. Failure to use caution may cause serious injury or illness.

- Avoid prolonged breathing of vapors.
- Keep face away from nozzle and gas tank/container opening.
- Keep away from eyes and skin.
- Never siphon by mouth.

- Check that the operator's presence controls, safety switches, and shields are attached and functioning properly. Do Not operate unless they are functioning properly.

## Operation

### **WARNING**

Operating engine parts, especially the muffler, become extremely hot. Severe burns can occur on contact and debris, such as leaves, grass, brush, etc. can catch fire.

- Allow engine parts, especially the muffler, to cool before touching.
- Remove accumulated debris from muffler and engine area.
- Install and maintain in working order a spark arrester before using equipment on forest-covered, grass-covered, or brush-covered unimproved land.

### **WARNING**

Engine exhaust contains carbon monoxide, which is an odorless deadly poison that can kill you.

**Do Not** run engine indoors or in a small confined area where dangerous carbon monoxide fumes can collect.

- Operate only in daylight or good artificial light, keeping away from holes and hidden hazards.
- Start the engine carefully according to instructions with feet well away from the blade.
- Never raise deck with blades running.
- Never operate the mower with damaged guards, shields, or covers. Always have safety shields, guards, switches and other devices in place and in proper working condition.
- Never mow without the discharge door. Do Not operate unless the discharge door, grass catcher, mulch plug, or rear discharge chute kit are in place and working properly.
- Grass catcher components are subject to wear, damage and deterioration, which could expose moving parts or allow objects to be thrown. Frequently check the components and replace them with the manufacturer's recommended parts when necessary.
- Do Not change the engine governor setting or overspeed the engine.

- Never attempt to make wheel height adjustments while the engine is running.
- Stop engine, wait for all moving parts to stop, remove the spark plug wire(s).
  - Before checking, cleaning or working on the mower.
  - After striking a foreign object or abnormal vibration occurs (inspect the mower for damage and make repairs before restarting and operating the mower).
  - Before clearing blockages.
  - Whenever you leave the mower.
- Stop engine, wait for all moving parts to stop:
  - Before refueling.
  - Before dumping the grass catcher.
  - Before making height adjustments.

### **WARNING**

Hands, feet, hair, clothing, or accessories can become entangled in rotating parts. Contact with the rotating parts can cause traumatic amputation or severe lacerations.

- **Do Not** operate the machine without guards, shields, and safety devices in place and working properly.
- **Keep hands, feet, hair, jewelry, or clothing away from rotating parts.**
- Keep clear of the discharge opening at all times.
- This mower was designed for one operator only. Keep all others away from mower during operation.
- **DO NOT** operate the mower when people, especially children, or pets are in the area.
- Be alert, slow down and use caution when making turns. Look behind and to the side before changing directions.
- Stop the blades, slow down, and use caution when crossing surfaces other than grass and when transporting the mower to and from the area to be mowed.
- Be aware of the mower discharge path and direct discharge away from others.

# Safety

---

- Do Not operate the mower under the influence of alcohol or drugs.
- Use extreme care when loading or unloading the machine into a trailer or truck.
- Use care when approaching blind corners, shrubs, trees, or other objects that may obscure vision.

## Slope Operation

Use **Extreme** caution when mowing and/or turning on slopes as loss of traction and/or tip-over could occur. The operator is responsible for safe operation on slopes.

### **⚠ DANGER**

**Operating on wet grass or steep slopes can cause sliding and loss of control. Loss of control and/or loss of operator's footing could result in a fall with an arm or leg getting under the mower or engine deck which may result in serious injury, death or drowning.**

- **Mow across slopes, never up and down.**
  - **Do Not mow slopes when grass is wet.**
  - **Do Not mow near drop-offs or near water.**
  - **Do Not mow excessively steep slopes.**
  - **Reduce speed and use extreme caution on slopes.**
  - **Avoid sudden turns or rapid speed changes.**
- When feasible, avoid operating the equipment in wet grass.
  - Progressively greater care is needed as the slope increases.
  - Remove or mark obstacles such as rocks, tree limbs, etc. from the mowing area. Tall grass can hide obstacles.
  - Watch for ditches, holes, rocks, dips and rises that change the operating angle, as rough terrain could overturn the machine.
  - Use extreme care with grass catchers or attachments. These can change the stability of the machine and cause loss of control.

## Maintenance and Storage

- Stop the engine and remove the spark plug wire(s). Wait for all movement to stop before adjusting, cleaning or repairing.
- Keep engine and engine area free from accumulation of grass, leaves, excessive grease or oil, and other debris which can accumulate in these areas. These materials can become combustible and may result in a fire.
- Let engine cool before storing and Do Not store near flame or any enclosed area where open pilot lights or heat appliances are present.
- Shut off fuel while storing or transporting. Do Not store fuel near flames or drain indoors.
- Park machine on level ground. Never allow untrained personnel to service machine.
- Remove spark plug wire before making any repairs.
- Use care when checking blades. Wrap the blade(s) or wear gloves, and use caution when servicing them. Only replace damaged blades. Never straighten or weld them.
- Keep hands and feet away from moving parts. If possible, Do Not make adjustments with the engine running.
- Keep all guards, shields and all safety devices in place and in safe working condition.
- Check all bolts frequently to maintain proper tightness.
- Frequently check for worn or deteriorating components that could create a hazard.
- All replacement parts must be the same as or equivalent to the parts supplied as original equipment.



## Safety and Instructional Decals

- Keep all safety signs legible. Remove all grease, dirt and debris from safety signs and instructional labels.
- Replace all worn, damaged, or missing safety signs.
- When replacement components are installed, be sure that current safety signs are affixed to the replaced components.
- If an attachment or accessory has been installed, make sure current safety signs are visible.
- New safety signs may be obtained from your authorized Exmark equipment dealer or distributor or from Exmark Mfg. Co. Inc.
- Safety signs may be affixed by peeling off the backing to expose the adhesive surface. Apply only to a clean, dry surface. Smooth to remove any air bubbles.
- Familiarize yourself with the following safety signs and instruction labels. They are critical to the safe operation of your Exmark commercial mower.



68-7410



94-8072

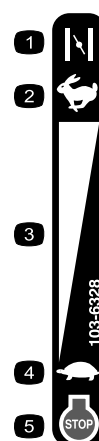

103-6328

EC21KABBCX

1. Choke
2. Fast
3. Continuous variable setting
4. Slow
5. Engine—stop

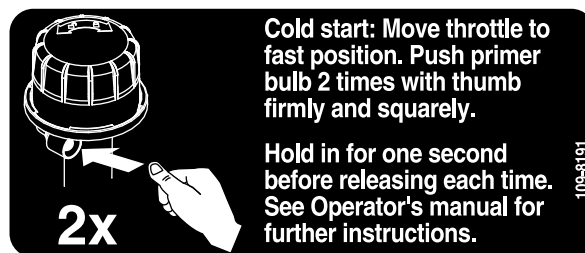

109-8191

EC21KABBC, EC21KAY, EC21KA, EC21KABBCCA, EC21KACA, EC21KAX, EC21KABBCY

# Safety

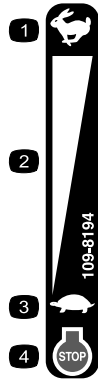

109-8194

EC21KABBCY, EC21KABBCCA

- 1. Fast
- 2. Continuous variable
- 3. Slow
- 4. Engine—stop setting

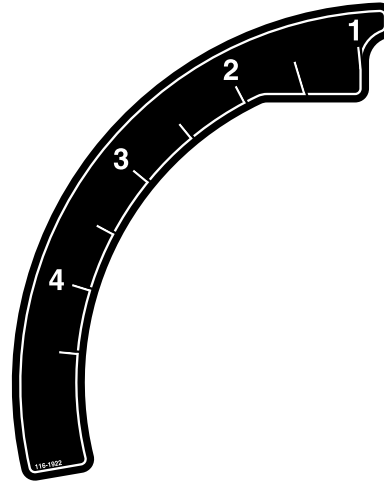

116-1922



109-9317



116-2685



117-2718



116-1900

**⚠ WARNING**



**To avoid serious injury or death:**

- Read and understand the operator's manual.
- Do NOT operate unless trained to safely use this machine.
- Do NOT operate without shields, guards, and safety devices in place and working.
- Do NOT operate unless discharge door, grass catcher, mulch plug, or rear discharge guard kit is in place.
- Pick up objects that could be thrown by the blades.
- Do NOT mow when people, especially children, or pets are in the area.
- Mow across slope - NOT up and down.
- Look behind when backing up.
- Hearing protection is recommended.

116-2737

116-2737

## Specifications

# Specifications

## Model Numbers

Serial Nos: 850,000 and Higher

EC21ASHN; EC21ASKA; EC21ASKAP; EC21HNBBC; EC21HNBBCX; EC21KA; EC21KACA; EC21KAX;  
EC21KAY; EC21KABBC; EC21KABBCCA; EC21KABBCX; EC21KABBCY

## Systems

### Engine

- Engine Specifications: See your Engine Owner's Manual
- RPM: 3000 (No Load): EC21ASHN
- RPM: 3300 (No Load): All units except EC21ASHN

### Fuel System

- Capacity:  
EC21ASHN, EC21KACA, EC21KABBCCA, EC21ASKA and EC21ASKAP Units:  
2.0 qt (1.9 L)  
All other units: 4.0 qt (3.8 L)
- Type of Fuel: Regular unleaded gasoline, 87 octane or higher; containing no more than 10% methanol or ethanol.
- Fuel Filter: Non-replaceable, in tank
- Fuel Shut-Off Valve:  
EC21KACA, EC21KABBCCA, EC21ASKA and EC21ASKAP Units Do Not have a shut-off valve.  
All other units have a shut-off valve.

### Safety Interlock System

For units without a Blade Brake Clutch: Operator must have the blade control bail depressed to start the engine. Releasing the blade control bail will cause the engine to stop.

### Transmission (Self Propelled Units)

Variable

Speed Range: 0–4.2 mph (6.8 km/hr)

### Cutting Deck

- Cutting Width: 21 inches (53.3 cm)
- Blade Brake: When the blade engagement control is moved to the disengaged position a friction brake pad stops the rotation of the blades.
- Blade Size: (1 ea.): 20.88 inches (53.0 cm)
- Deck: 21 inches rigid. Deck design allows for bagging, mulching or rear discharge.
- Cutting Height Adjustment:  
Adjusts from 1 inch (2.5 cm) to 4 1/2 inches (11.4 cm) in 1/2 inch (1.3 cm) increments.
- Mulching Kit: Standard on EC21KA, EC21KABBC, EC21HNBBC, EC21KACA, EC21KABBCCA, EC21KAX, EC21KAY, EC21KABBCX, and EC21KABBCY Units
- Rear Discharge Kit: Optional

## Dimensions

### Curb Weight:

98-122 lb (44-55 kg) Weights may vary slightly depending on engine option.

### Overall Width:

22 inches (55.9 cm)

### Overall Length and Height at 2 1/2 inch Cutting Height:

Handle Setting	Length	Height
High	61.00 inches (154.9 cm)	39.00 inches (99.1 cm)
Medium	63.00 inches (160.0 cm)	37.50 inches (95.3 cm)
Low	64.50 inches (163.8 cm)	35.00 inches (88.9 cm)

# Product Overview

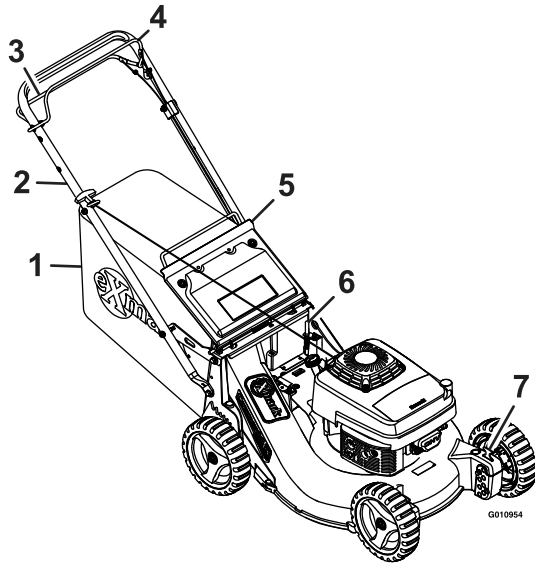

Figure 3

- |  |                                 |
|--|---------------------------------|
| 1. Grass bag                                 | 5. Discharge door               |
| 2. Handle                                    | 6. Rear wheel height adjustment |
| 3. Drive Bail<br>(Self-Propelled Units Only) | 7. Front wheel height adjuster  |
| 4. Blade Control Bail                        |                                 |

# Operation

**Note:** Determine the left and right sides of the machine from the normal operating position.

## Controls

### Blade Control Bail

Located on the upper handle as shown in Figure 4.

When the blade control bail is depressed, the system senses that the operator is in the normal operator's position.

- **For Units with a Blade Brake Clutch:** When the blade control bail is released, the system senses that the operator has moved from the normal operating position and will stop the blade.
- **For Units without a Blade Brake Clutch:** When the blade control bail is released, the system senses that the operator has moved from the normal operating position and will kill the engine.

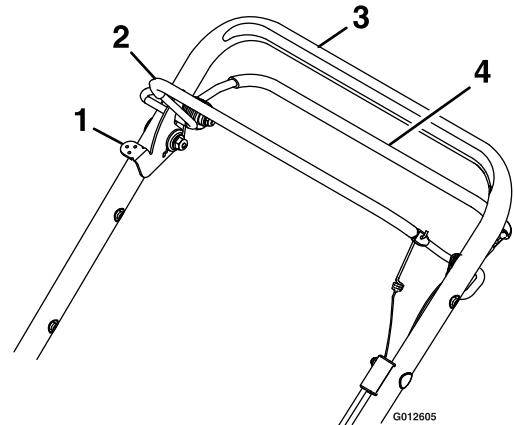

Figure 4

Blade Brake Unit Shown

1. Blade control lock lever (Blade Brake Units Only)
2. Blade control bail
3. Handle
4. Drive bail (Self-Propelled Units Only)

### Self-Propel Drive Bail (Self-Propelled Units Only)

Located on the upper handle as shown in Figure 4.

When the self-propel drive bail is squeezed, the unit will move forward based on how far the bail is depressed toward the handle. When this bail is released the unit will stop moving.

# Operation

## Throttle-Choke Lever (EC21KABBCX, EC21KABBCY, EC21KABBCCA)

Located on the left side of the engine as shown in Figure 11.

The lever is used to control engine speed. Moving the throttle to the full forward (Choke) position will place the lever in the choke position. The choke aids in starting a cold engine. Moving the throttle control forward will increase engine speed and moving it to the rear will decrease engine speed.

The throttle-choke control also includes an engine kill position. Moving the lever into the full rearward (Stop) position will kill the engine.

**Note:** Some units will not have the choke position.

## Choke Control (EC21HNBBC, EC21HNBBCX)

Located on the front left side of the engine as shown in Figure 10.

The choke aids in starting a cold engine. Pulling outward will place the control in the choke position. Pushing the control inward shuts off the choke.

## Blade Control Lock Lever (Blade Brake Clutch Units Only)

The blade control lock lever is located on the right side of the handle next to the Blade Control Bail as shown in Figure 4.

Moving the blade control lock lever into the full forward position releases the blade control bail. Squeezing the blade control bail against the handle engages the blade. Releasing the blade control bail automatically disengages the blade. The blade control lock lever will reset to lock the blade control bail.

## Engine Stop Switch

Located on the left side of the engine in front of the fuel tank as shown in Figure 5. The engine stop switch is used on EC21HNBBC, EC21HNBBCX, and EC21KABBC (see Figure 10 and Figure 11 ).

Press the switch to “STOP” to kill the engine. Press “|” before starting the engine.

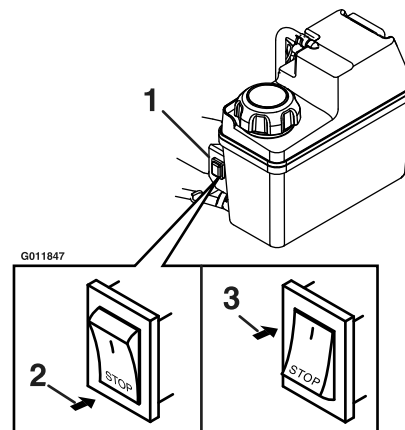

**Figure 5**

Clear plastic cover removed for clarity

1. Engine stop switch
2. Press “STOP” to kill engine
3. Press “I” before starting engine

## Fuel Shut-Off Valve

The fuel shut off valve is located between the carburetor and the fuel tank. The fuel shut off valve shuts off the flow of fuel when the machine will not be used for a few days, when parking inside a building, and during transport to and from the job.

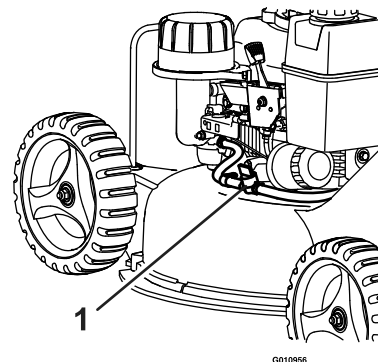

**Figure 6**

Kawasaki Unit

1. Fuel valve

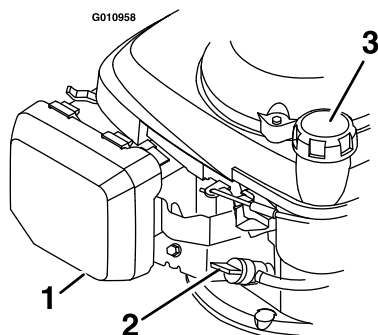

**Figure 7**  
Honda Unit

1. Air cleaner
2. Fuel valve
3. Fuel cap

On EC21KA, EC21KABBC, EC21KAX, EC21KAY, EC21KABBCX, EC21KABBCY, and EC21ASHN units, rotate the valve 1/4 turn clockwise to shut off fuel. Rotate the valve 1/4 turn counterclockwise to turn on fuel.

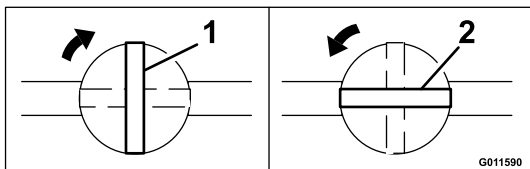

**Figure 8**

1. Rotate clockwise to close
2. Rotate counterclockwise to open

On EC21HNBBC and EC21HNBBCX units, the fuel shut off valve is located on the engine as shown in Figure 9. Rotate 1/4 turn clockwise to shut off fuel. Rotate the valve 1/4 turn counterclockwise to turn on fuel.

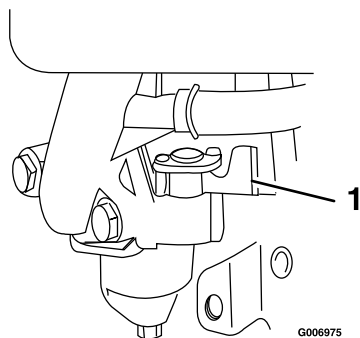

**Figure 9**

1. Fuel valve

## Pre-Start

Fill fuel tank. For best results use only clean, fresh regular grade unleaded gasoline with an octane rating of 87 or higher. To ensure freshness, purchase only the quantity of gasoline that you expect to use in 30 days. Using unleaded gasoline results in fewer combustion deposits and longer engine life. See Engine Owner's Manual.

**Important:** Never use methanol, gasoline containing methanol, gasohol containing more than 10% ethanol, premium gasoline, or white gas because the fuel system could be damaged.

**Do Not** add oil to gasoline.

**Do Not** use gasoline that has been stored since the last mowing season or longer.

**Do Not** overfill fuel tank. Never fill the fuel tank so that the fuel level rises above a level that is 1/2 inch below the bottom of the filler neck to allow for fuel expansion and prevent fuel spillage.

Make sure you understand the controls, their locations, their functions, and their safety requirements.

Refer to the Maintenance section and perform all the necessary inspection and maintenance steps.

## Operating Instructions

### Handle Adjustment

The height of the handle can be adjusted for comfortable operation. Stand behind the handle to determine the height. To adjust the handle height, position the hardware into one of the three holes in the handle bracket.

### Open the Fuel Shut-Off Valve

Rotate the valve 1/4 turn counterclockwise to turn the fuel on (if equipped).

### Starting the Engine

1. Connect the wire to the spark plug.

# Operation

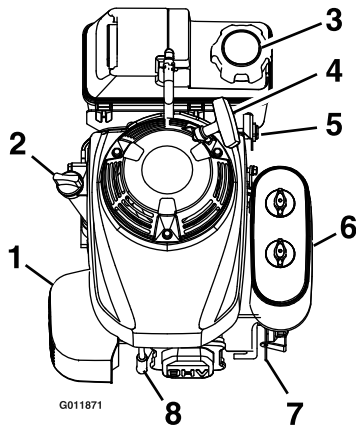

**Figure 10**  
Honda unit

1. Muffler
2. Oil fill/dipstick
3. Fuel tank cap (fuel tank varies)
4. Recoil starter handle (located on handle bar for zone start units)
5. Engine stop switch (if equipped)
6. Air filter
7. Choke
8. Spark plug

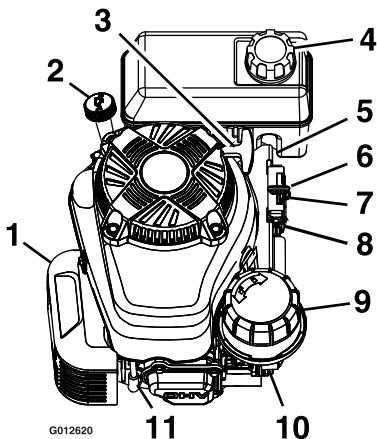

**Figure 11**

Kawasaki units with large fuel tank shown

1. Muffler
2. Oil fill/dipstick
3. Recoil starter handle
4. Fuel tank cap (fuel tank varies)
5. Engine stop switch (if equipped)
6. Throttle-Choke (if equipped)
7. Throttle Only (if equipped)
8. Oil filter
9. Air cleaner
10. Primer bulb (if equipped)
11. Spark plug

2. Open the fuel valve.

3. **For EC21KABBCX Unit:** Move the choke control to the Choke position

**For EC21KABBC Unit:** Turn the engine stop switch to “|” (see Figure 5).

**For EC21KABBC, EC21KABBCCA, EC21KABBCY, EC21KAX, EC21KACA, and EC21KAY Units:** Press the primer bulb two times (see Figure 12).

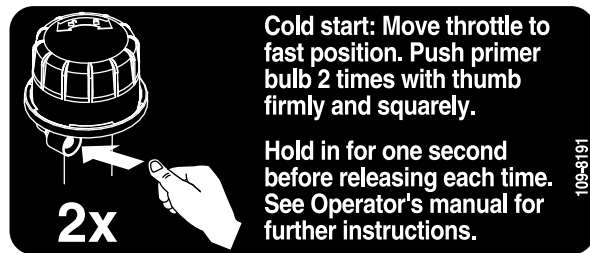

**Figure 12**

**For EC21HNBBC and EC21HNBBCX Units:** Turn the engine stop switch to “|” and pull outward on the choke control.

**Note:** Do Not use the choke when the engine is warmed up.

4. **For units without a Blade Brake Clutch:** Hold the blade control bail to the handle.
5. Pull the starter handle lightly until you feel resistance, then pull it sharply. Allow the rope to return slowly.
6. **For EC21KABBCCA, EC21KABBCX and EC21KABBCY Units:** When the engine starts, move the throttle control to the Fast position.
7. **For EC21HNBBC and EC21HNBBCX Units:** Gradually push in the choke control as the engine warms up.

## Stopping the Engine

1. Bring the unit to a full stop.
  - **For units without a Blade Brake Clutch:** Release the blade control bail. Both the engine and the blade should stop within three seconds.
  - **For units with a Blade Brake Clutch:** Release the blade control bail and the blade control lock lever resets. The blade should stop within three seconds; the engine will continue to run.



**EC21KABBCCA, EC21KABBCX, and EC21KABBCY:** Move the throttle to the (Stop) position to kill the engine.

**EC21KABBC, EC21HNBBXC, and EC21HNBBC:** Press the switch to “STOP” to kill the engine (see Figure 5).

**Note:** If the blade does not stop within 3 seconds after releasing the blade control bail, contact an Authorized Service Dealer.

2. Close the fuel shut-off valve, if equipped, when the machine will not be in use for a few days, when transporting, or when the unit is parked inside a building.

## Operating the Self-Propel Drive (Self-Propelled Units Only)

The lawn mower is variable speed, the more you squeeze the drive bail the faster the machine travels.

1. Start the engine.
2. Squeeze the drive bail against the handle (see Figure 4).

**Note:** You can vary the ground speed by increasing or decreasing the distance between the ground speed control bail and the handle. Lower the control bail to decrease the ground speed when you are making a turn or if the lawn mower is moving too fast for you. If you lower the control bail too far the lawn mower stops self-propelling. Squeeze the ground speed control bail closer to the handle to increase the ground speed. When you hold the ground speed control bail tight against the handle, the lawn mower self-propels at the maximum ground speed. Release the drive bail to stop moving when you use the lawn mower for trimming or whenever you leave the lawn mower.

3. To disengage the self-propel drive, release the drive bail.

**Note:** The mower comes with freewheeling clutches which make it easier to pull the mower rearward. To disengage the clutches, you may need to push the mower forward one inch (2.5 cm) or more after you release the self-propel drive bail.

## Operating the Blade Control Bail (Units Without Blade Brake Clutch)

1. Squeeze the blade control bail against the handle.
2. Start the engine.
3. When the blade control bail is squeezed against the handle, the blade should engage.
4. Release the blade control bail. Both the engine and the blade should stop.

## Operating the Blade Control Lever (Blade Brake Clutch Units Only)

1. Start the engine.
2. Push and hold the blade control lock lever forward to release the blade control bail (Figure 13).

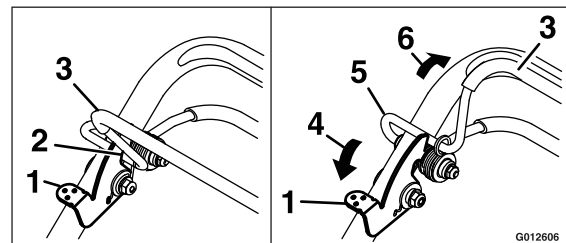

**Figure 13**

- |                             |                           |
|-----------------------------|---------------------------|
| 1. Blade control lock lever | 4. Push forward           |
| 2. Locked position          | 5. Unlocked position      |
| 3. Blade control bail       | 6. Squeeze against handle |

3. Squeeze the blade control bail against the handle and release the blade control lock lever; the blade should engage.
4. Release the blade control bail to disengage the blade. The blade control lock lever will reset to lock the blade control bail.

## Using the Mulch Plug

Occasionally you may wish to use the mulch plug to mulch the grass and leaf clippings back into the lawn.

- Installing the Mulch Plug:
  1. Stop the engine and wait for all moving parts to stop.
  2. Remove the grass bag if it is on the mower.
  3. Raise the discharge door and insert the mulch plug into the discharge opening. The lip on the plug will snap into the mower housing.

# Operation

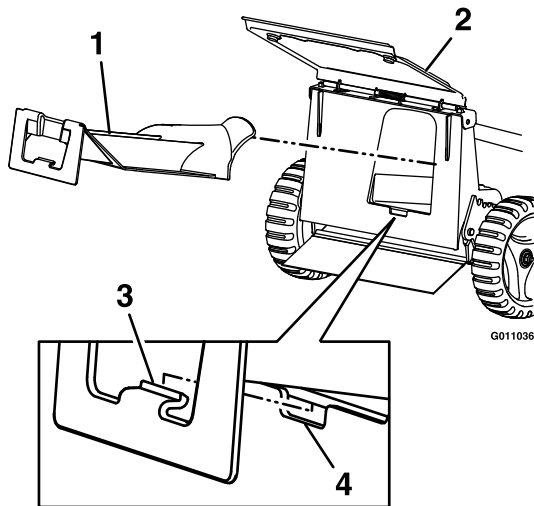

Figure 14

1. Mulch plug
2. Discharge door
3. Lip
4. Mower housing

4. Lower the discharge door.

- Removing the Mulch Plug:

**Note:** When grass is thick and lush, clippings may collect on and around the discharge tunnel plug. This may make it difficult to remove the plug. Clean the plug thoroughly after each use.

1. To remove the mulch plug, raise the discharge door and pull the mulch plug out of the discharge tunnel.
2. Lower the discharge door.

## Checking the Blade Brake Clutch (Blade Brake Clutch Units Only)

Check the Blade Brake Clutch (BBC) system before each use to ensure that it is operating properly.

Normal Test:

1. Stop the engine and wait for all moving parts to stop.
2. Move the lawn mower onto a paved surface in a non-windy area.
3. Set all four wheels to the 2 1/2 inches (6.4 cm) cutting height (see Figure 16 and Figure 17)
4. Take a half sheet of newspaper and crumple it into ball small enough to go under the deck (about 3 inches or 7.6 cm in diameter) as shown in Figure 15.

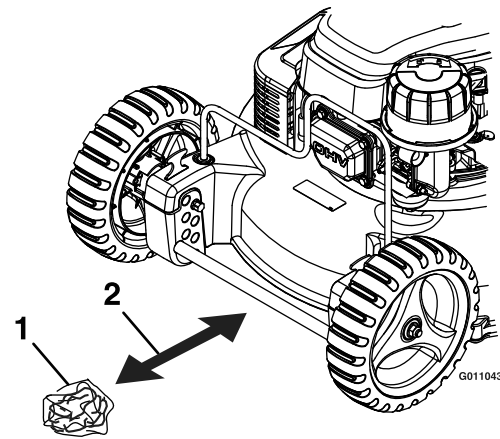

Figure 15

1. Crumpled newspaper
2. 5 inches (12.7 cm)

5. Place the ball of newspaper 5 inches (12.7 cm) in front of the lawn mower.
6. Start the engine.
7. Push the blade control lock lever forward to release the blade control bail (Figure 4).
8. Squeeze the blade control bail against the handle. blade should engage.
9. Release the blade control bail. You should hear a “bang.” The blade should stop in three seconds. The blade control lock lever should reset to lock the blade control bail.
10. Immediately push the lawn mower over the newspaper ball.
11. Stop the engine and wait for all moving parts to stop.
12. Walk around the lawn mower to check for the newspaper ball. If the ball did not go under the deck, repeat steps 6 through 11.
13. Pull the lawn mower away from the newspaper. If the newspaper ball unravels or is shredded, the blade has not properly stopped, resulting in an unsafe operating condition. **Contact an Authorized Service Dealer.**

## **⚠ DANGER**

If the blade brake clutch system is inoperative, the blade will continue to rotate when you release the blade control bail. Contact with the blade could occur, causing serious injury.

- Check the BBC operation before each use.
- Never use the BBC-equipped lawn mower with an inoperative safety system.
- Take your lawn mower to an Authorized Service Dealer for repair if the safety system fails to operate properly.

## Test Using the Grass Bag

1. Install the empty grass bag on the discharge tunnel.
2. Start the engine.
3. **For units with a Blade Brake Clutch:** Push the blade control lock lever forward to release the blade control bail (Figure 4).
4. Squeeze the blade control bail against the handle.
5. The bag should begin to inflate, indicating that the blade is engaged and rotating.
6. Release the blade control bail. If the bag does not immediately deflate, it indicates that the blade is still rotating. The blade brake clutch mechanism may be deteriorating, and, if ignored could result in an unsafe operating condition. Have the lawn mower inspected and serviced by an Authorized Service Dealer.

## Adjusting the Cutting Height

The rear wheels are adjusted together with a height adjustment rod located on the mower housing by the left rear wheel. The front wheels are adjusted separately by removing the front wheel shaft assemblies, adjusting the height, and then replacing the shaft assemblies. The cutting height can be adjusted from 1 inch (25 mm) to 4 1/2 inches (114 mm) in 1/2 inch (12.7 mm) increments.

## **⚠ WARNING**

Adjusting the cutting height levers could bring your hands into contact with a moving blade. A moving blade can cause serious injury.

- Stop the engine and wait for all movement to stop before adjusting the cutting height.
- Do Not put your fingers under the housing when adjusting the cutting height.

### • Rear Wheel Adjustment:

1. Pull the wheel height adjustment rod upward to release the pin from the notch in the adjustment bracket (Figure 16).

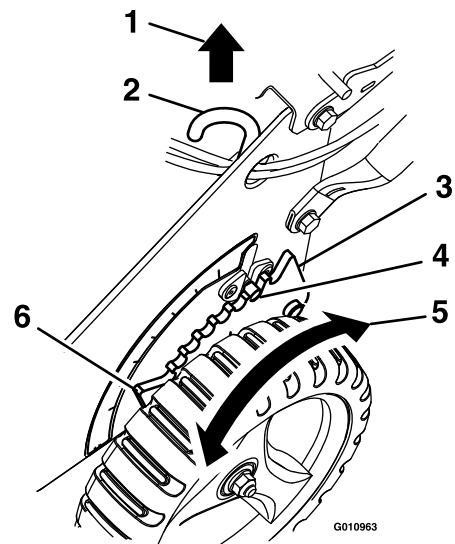

**Figure 16**

- |                                |                                  |
|--------------------------------|----------------------------------|
| 1. Pull upward                 | 4. Pin                           |
| 2. Wheel height adjustment rod | 5. Rotate to desired setting rod |
| 3. Adjustment bracket          | 6. Indicator                     |

2. Apply downward pressure or lift the housing to rotate the height adjustment bracket. Use the indicator to determine the desired setting.
3. Release the wheel height adjustment rod to set the pin securely in the desired notch.

### • Front Wheel Adjustment

1. Pull up on the height adjuster and pull the front wheel shaft assembly outward as shown in Figure 17.

# Operation

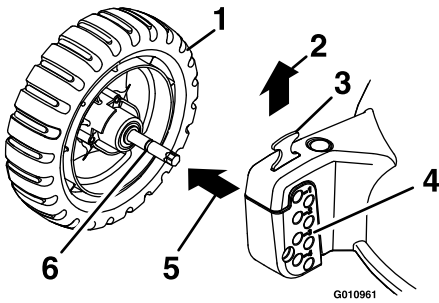

Figure 17

- |                               |                                     |
|-------------------------------|-------------------------------------|
| 1. Front wheel shaft assembly | 4. Front quadrant block cut heights |
| 2. Pull up                    | 5. Pull outward                     |
| 3. Height adjuster            | 6. Shaft groove                     |

2. Insert the front wheel shaft assembly into the desired cut height setting in the front quadrant block. Lower the height adjuster into the groove on the front wheel shaft. Pull and push the wheel shaft assembly to make sure it has locked into place.

## Using the Grass Bag

- Installing the Grass Bag
  1. Stop the engine and wait for all moving parts to stop.
  2. Open the rear door.
  3. Grasp the handle on the bag and set the rear of the bag frame onto the handle bracket notch (Figure 18).

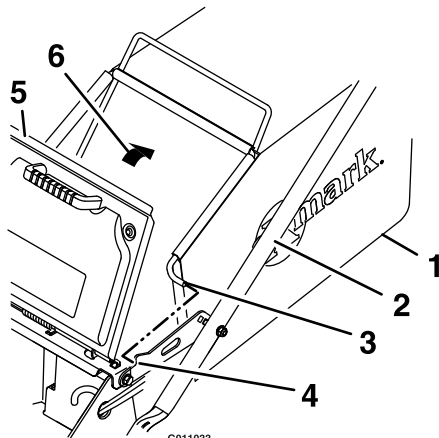

Figure 18

- |              |                         |
|--------------|-------------------------|
| 1. Bag       | 4. Handle bracket notch |
| 2. Handle    | 5. Rear door            |
| 3. Bag frame | 6. Lower                |

4. Once the bag is seated, lower the rear door onto the bag.

- Mowing with the Grass Bag

## ⚠ WARNING

A worn grass bag could allow small stones and other similar debris to be thrown in the operator's or bystander's direction. Thrown objects can result in serious personal injury or death to the operator or bystanders.

**Check the grass bag frequently. If it is damaged, install a new Exmark replacement bag.**

Cut the grass until the bag is full.

**Note: Do Not** overfill the bag.

- Removing the Grass Bag
  1. Stop the engine and wait for all moving parts to stop.
  2. Raise the rear discharge door and grasp the handle on the bag.
  3. Lift the bag off of the lawn mower and lower the rear discharge door.
  4. Gradually tip the bag forward to empty the clippings.
  5. To install the bag, refer to the section on Installing the Grass Bag.

## ⚠ DANGER

If the discharge door does not close completely, the lawn mower could throw objects. Thrown objects can result in serious personal injury or death to the operator or bystanders.

- Never open the door to the discharge opening when the engine is running.
- If you cannot close the door because the grass clippings clog the discharge area, stop the engine and gently move the discharge door handle back and forth until you can close the door completely. If you still cannot close the door, remove the obstruction with a stick, not your hand.

## Operating Tips

- Review the Safety section and read this manual carefully before operating the lawn mower.
- Set the engine speed to the fastest position for the best cutting results.
- Maintain a sharp blade throughout the cutting season. Periodically file down nicks on the blade. Replace the blade when necessary with an original Exmark replacement blade.
- Clean the air filter frequently. Mulching stirs up more clippings and dust which clogs the air filter and reduces engine performance.
- For light leaf coverage, set all the wheels at the same cutting height setting.
- If there are more than 5 inches (12.7 cm) of leaves on the lawn, set the front cutting height 1 or 2 notches higher than the rear cutting height. This makes it easier to feed the leaves under the lawn mower deck.
- Slow down your mowing speed if the lawn mower does not cut the leaves finely enough.
- If you mow over oak leaves, you can add lime to the grass in the spring to reduce the acidity of the oak leaves.

## Cutting Grass

- Grass grows at different rates at different times of the year. In the summer heat, it is best to cut grass at the 2 1/2 inch (64 mm), 3 inch (76 mm), or 3 1/2 inch (89 mm) cutting height settings. Cut only about a third of the grass blade at a time. Do Not cut below the 2 1/2 inch (64 mm) setting unless the grass is sparse or it is late fall when grass growth begins to slow down.
- When cutting grass over 6 inches (15 cm) tall, first mow at the highest cutting height setting and walk slower; then mow again at a lower setting for the best lawn appearance. If the grass is too long and the leaves clump on top of the lawn, the lawn mower may plug and cause the engine to stall.
- Alternate the mowing direction. This helps disperse the clippings over the lawn for even fertilization.

If the finished lawn appearance is unsatisfactory, try one or more of the following:

- Sharpen the blade.
- Walk at a slower pace while mowing.
- Cut the grass more frequently.
- Overlap cutting swaths instead of cutting a full swath with each pass.
- Set the cutting height on the front wheels one notch lower than the rear wheels. For example, set the front wheels at 2 1/2 inches (64 mm) and the rear wheels at 3 inches (76 mm).

## Cutting Leaves

- After cutting the lawn, ensure that half of the lawn shows through the cut leaf cover. You may need to make more than one pass over the leaves.

# Maintenance

**Note:** Determine the left and right sides of the machine from the normal operating position.

## ⚠ WARNING

If you leave the wire on the spark plug, someone could accidentally start the engine. Accidental starting of the engine could seriously injure you or other bystanders.

Disconnect the wire from the spark plug before you do any maintenance. Set the wire aside so that it does not accidentally contact the spark plug.

## ⚠ WARNING

Tipping the lawn mower may cause the fuel to leak from the carburetor or the fuel tank. Gasoline is extremely flammable, highly explosive, and under certain conditions, can cause personal injury or property damage.

Avoid fuel spills by running the engine dry or by removing the gasoline with a hand pump; never siphon.

## ⚠ WARNING

The engine can become very hot. Touching a hot engine can cause severe burns.

Allow the engine to cool completely before service or making repairs around the engine area.

## Recommended Maintenance Schedule(s)

Maintenance Service Interval	Maintenance Procedure
After the first 5 hours	<ul style="list-style-type: none"> <li>• Change the engine oil.</li> </ul>
Before each use or daily	<ul style="list-style-type: none"> <li>• Check the engine oil level.</li> <li>• Check the stopping time of the blade brake. The blade must stop within 3 seconds of releasing the bail; if it does not, contact an Authorized Service Dealer for repair.</li> <li>• Check the mower blade and the engine mounting fasteners.</li> <li>• Check for loose hardware.</li> <li>• Check the Blade Brake Clutch Bail operation (Blade Brake Clutch Units Only)</li> <li>• Clean the grass build-up from under the deck.</li> <li>• Clean the discharge tunnel and plug.</li> </ul>
Every 25 hours	<ul style="list-style-type: none"> <li>• Clean the foam pre-cleaner (Kawasaki Units).</li> <li>• Clean the cover, base, foam and paper elements (EC21ASHN Units).</li> <li>• Clean the cover, base, foam and paper elements (EC21HNBBC and EC21HNBBCX Units).</li> </ul>
Every 40 hours	<ul style="list-style-type: none"> <li>• Check the condition of the belt(s).</li> </ul>
Every 50 hours	<ul style="list-style-type: none"> <li>• Change the engine oil. (May need more often under severe conditions.)</li> <li>• Check for leaks in the fuel systems and /or deteriorating fuel hose.</li> <li>• Clean under the belt cover (self-propelled units only).</li> <li>• Clean the blade brake clutch shield.</li> <li>• Clean under the cover plate (Non-BBC Units).</li> </ul>

Maintenance Service Interval	Maintenance Procedure
Every 100 hours	<ul style="list-style-type: none"> <li>Change the oil filter (EC21KA, EC21KABBC, EC21KAX, EC21KAY, EC21KABBCX, EC21KABBCY, EC21KACA, and EC21KABBCCA Units).</li> <li>Check the spark plugs.</li> <li>Clean the fuel filter element.</li> </ul>
Every 250 hours	<ul style="list-style-type: none"> <li>Replace the air filter elements (EC21ASHN Units). (May need more often if they are damaged or excessively dirty.)</li> <li>Replace the air filter elements (EC21HNBBC and EC21HNBBCX Units). (May need more often if they are damaged or excessively dirty.)</li> </ul>
Every 300 hours	<ul style="list-style-type: none"> <li>Replace the paper air filter (Kawasaki Units). (May need more often in dusty conditions. See the Engine manual for additional information.)</li> </ul>
Yearly or before storage	<ul style="list-style-type: none"> <li>Empty the fuel tank before repairs as directed or before storage.</li> </ul>

## Periodic Maintenance

### Check Engine Oil Level

**Service Interval: Before each use or daily**

1. Stop engine and wait for all moving parts to stop. Make sure unit is on a level surface.
2. Check with engine cold.
3. Clean area around dipstick. Remove dipstick and wipe oil off. Reinsert the dipstick and push it all the way down into the tube. **Do Not** screw into place. Remove the dipstick and read the oil level.

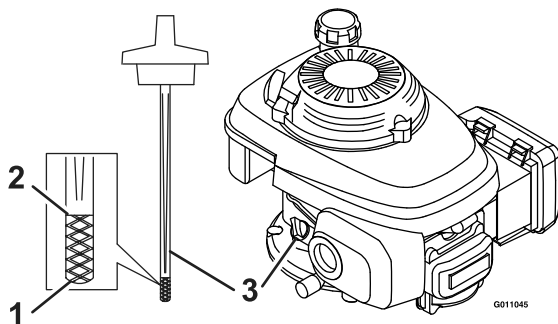

**Figure 19**  
Honda Engine

1. Lower limit mark
2. Upper limit mark
3. Dipstick

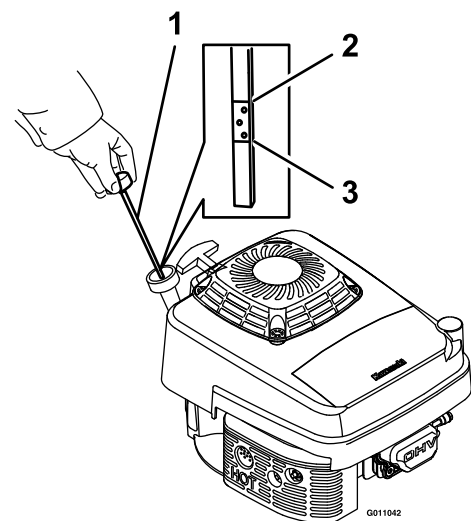

**Figure 20**  
Kawasaki Engine

1. Dipstick
2. Full
3. Add

4. If the oil level is low, wipe off the area around the oil fill cap, remove cap and fill to the "FULL" mark on the dipstick. Use oil as specified in Engine Owner's Manual. **Do Not** overfill.

**Important:** Do Not operate the engine with the oil level below the "LOW" (or "ADD") mark on the dipstick, or over the "FULL" mark.

### Checking the Blade Brake Clutch (Blade Brake Clutch Only)

**Service Interval: Before each use or daily**

# Maintenance

Refer to **Checking the Blade Brake Clutch** in the Operating Instructions section.

## Check the Mower Blade

### Service Interval: Before each use or daily

Always mow with a sharp blade. A sharp blade cuts cleanly and without tearing or shredding the grass blade.

1. Stop the engine and wait for all moving parts to stop.
2. Disconnect the wire from the spark plug (Figure 10 and Figure 11).
3. Drain the gasoline from the fuel tank. Refer to **Emptying the Fuel Tank and Cleaning the Fuel Filter** section.
4. Tip the lawn mower onto its right side.
5. Inspect the blade for sharpness and wear, especially where the flat and the curved parts meet (see Figure 21). Because sand and abrasive material can wear away the metal that connects the flat and curved parts of the blade, check the blade before using the lawn mower. If you notice a slot or wear (Figure 21B and Figure 21C), replace the blade.

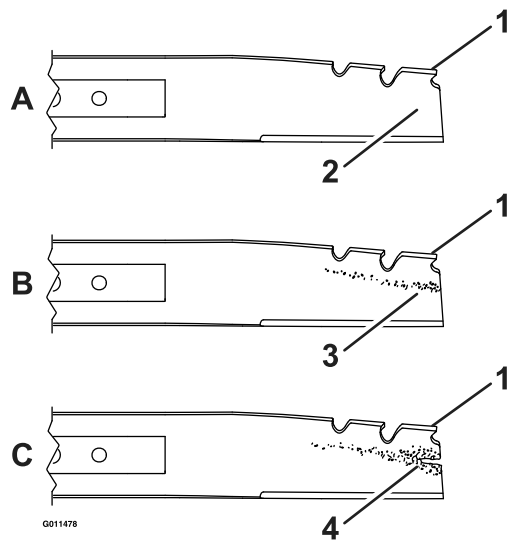

Figure 21

- |         |         |
|---------|---------|
| 1. Sail | 3. Wear |
| 2. Flat | 4. Slot |

**Note:** For the best performance, install a new blade before the cutting season begins. During the year, file down any small nicks to maintain the cutting edge.

## ⚠ DANGER

A worn or damaged blade can break. A piece of the blade could be thrown into the operator's or bystander's area, resulting in serious personal injury or death.

- Inspect the blade periodically for wear or damage.
- Replace a worn or damaged blade.

If it is necessary to remove the blade for replacement or sharpening, complete the following steps:

- To remove the blade, use a block of wood to hold the blade steady (see Figure 22). Make sure to grasp the end of the blade using a rag or a thickly padded glove.
  - **For Blade Brake Clutch Units:** Remove the blade nuts, blade support, and blade.
  - **For Units without a Blade Brake Clutch:** Remove the blade bolt, blade support, and blade.

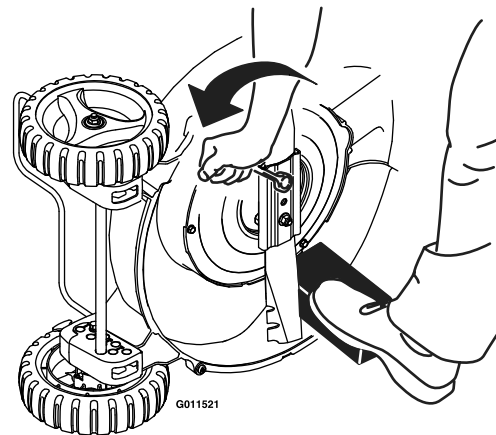
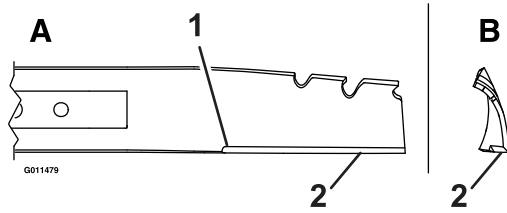

Figure 22

- For Sharpening: File the top side of the blade to maintain its original cutting angle (Figure 23A and B) and inner cutting edge radius (Figure 23A). The blade will remain balanced if you remove the same amount of material from both cutting edges.

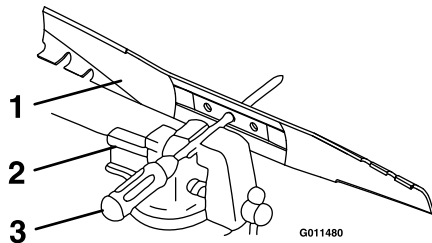



**Figure 23**

1. Inner cutting edge radius 2. Cutting angle

C. Check the balance of the blade by placing the center hole of the blade over a nail or screwdriver shank clamped horizontally in a vise (Figure 24). If either end of the blade rotates downward, file that end (not the cutting edge). The blade is properly balanced when neither end drops.



**Figure 24**

1. Blade  
2. Vise  
3. Screwdriver

D. For Installation: Make sure to grasp the end of the blade using a rag or a thickly padded glove.

For Blade Brake Clutch Units: Install a sharp, balanced Exmark blade, blade support, and the blade nuts. The sail of the blade must point toward the top of the lawn mower housing for proper installation. Torque the blade nuts to 23-27 ft-lb (31-37 N m).

For Units without a Blade Brake Clutch: Install a sharp, balanced Exmark blade, blade support, and blade bolt. The sail of the blade must point toward the top of the lawn mower housing for proper installation. Torque the blade bolt to 35-45 ft-lb (47-61 N m).

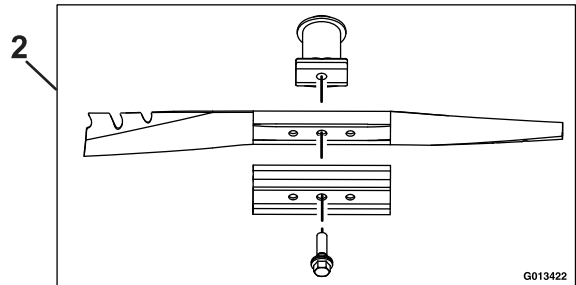
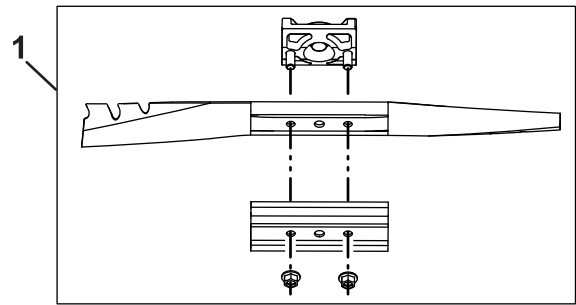

**Figure 25**

1. Blade Brake Clutch Units  
2. Units without a Blade Brake Clutch

6. Return the lawn mower to its upright position.  
7. Connect the wire to the spark plug.

## Check for Loose Hardware

### Service Interval: Before each use or daily

1. Stop engine, wait for all moving parts to stop.
2. Visually inspect machine for any loose hardware or any other possible problem. Tighten hardware or correct the problem before operating.

## Check the Blade Brake Clutch Bail Operation (Blade Brake Clutch Units Only)

### Service Interval: Before each use or daily

Check the Blade Brake Clutch (BBC) bail operation for any operation problems or deteriorating components, such as the spring. Replace components or correct any problems before operating. Refer to **Operating the Blade Control Lever** in Operation.

## Service Air Filter (Kawasaki Units)

**Service Interval: Every 25 hours—Clean the foam pre-cleaner (Kawasaki Units).**

**Every 300 hours—Replace the paper air filter (Kawasaki Units). (May need more often in dusty conditions. See the Engine manual for additional information.)**

**Note: Do Not** operate the engine without the air filter assembly; extreme engine damage will occur.

1. Stop engine, wait for all moving parts to stop.
2. Disconnect the wire from the spark plug (Figure 11).
3. Remove the cover and clean it thoroughly.

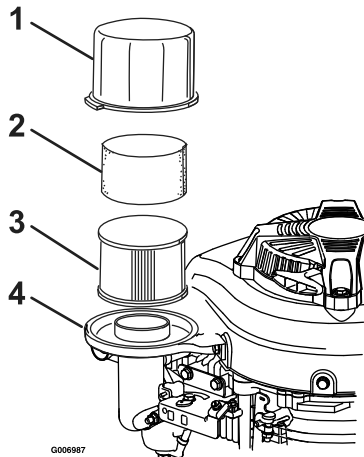

**Figure 26**

EC21KA, EC21KACA, EC21KAX, EC21KAY,  
EC21KABBC, EC21KABBCCA, EC21KABBCX,  
EC21KABBCY Units

- |                 |                     |
|-----------------|---------------------|
| 1. Cover        | 3. Paper air filter |
| 2. Foam element | 4. Air filter base  |

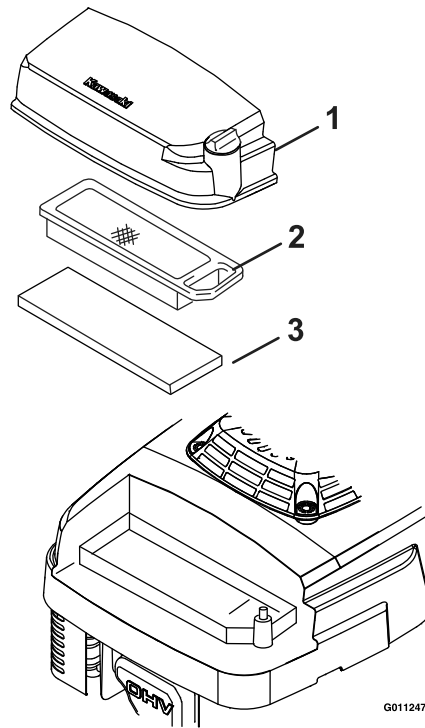

**Figure 27**

EC21ASKA and EC21ASKAP Units

- |                     |                 |
|---------------------|-----------------|
| 1. Cover            | 3. Foam element |
| 2. Paper air filter |                 |

4. Remove the paper air filter and discard it as required.

**Note: Do Not** try to clean a paper air filter.

5. Remove the foam element and wash it with a mild detergent and water, then blot it dry.
6. Saturate the element with clean engine oil, then squeeze it (Do Not twist) to remove the excess oil.
7. Install the foam element.
8. Install the new paper air filter.
9. Install the cover.

## Service Air Filter (EC21ASHN Units)

**Service Interval: Every 25 hours—Clean the cover, base, foam and paper elements (EC21ASHN Units).**

**Every 250 hours—Replace the air filter elements (EC21ASHN Units). (May need more often if they are**

**damaged or excessively dirty.)**

**Note:** Do Not operate the engine without the air cleaner assembly; extreme engine damage will occur.

1. Stop the engine and wait for all moving parts to stop.
2. Disconnect the wire from the spark plug (Figure 10).
3. Press down on the latch tabs on top of the air cleaner cover.

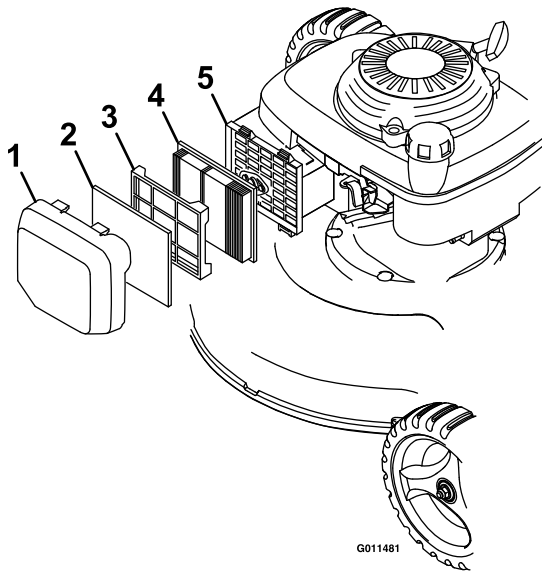

**Figure 28**

- |                 |                        |
|-----------------|------------------------|
| 1. Cover        | 4. Paper filter        |
| 2. Foam element | 5. Air cleaner housing |
| 3. Screen grid  |                        |

4. Open the cover
5. Remove screen grid and paper filter assembly.
6. If the air filter is damaged or is wet with oil or fuel, replace it.
7. If the air filter is dirty, tap it on a hard surface several times or blow compressed air less than 30 psi (207 kPa) through the side of the filter that faces the engine. If the paper element is excessively dirty, replace it.

**Note:** Do Not brush the dirt off the filter; brushing forces dirt into the fibers.

8. Remove the foam element and wash it with a mild detergent and water, then blot it dry.
9. Saturate the element with clean engine oil, then squeeze it (Do Not twist) to remove the excess oil.

10. Install the foam element.

11. Remove dirt from the air cleaner housing and cover using a moist rag. **Do Not wipe dirt into the air duct.**

12. Install the filter.

13. Close the cover.

## Service Air Filter (EC21HNBBC and EC21HNBBCX Units)

**Service Interval:** Every 25 hours—Clean the cover, base, foam and paper elements (EC21HNBBC and EC21HNBBCX Units).

**Every 250 hours—**Replace the air filter elements (EC21HNBBC and EC21HNBBCX Units). (May need more often if they are damaged or excessively dirty.)

**Note:** Do Not operate the engine without the air cleaner assembly; extreme engine damage will occur.

1. Stop the engine and wait for all moving parts to stop.
2. Disconnect the wire from the spark plug (Figure 10).
3. Remove the two wing nuts that secure the cover (Figure 29).

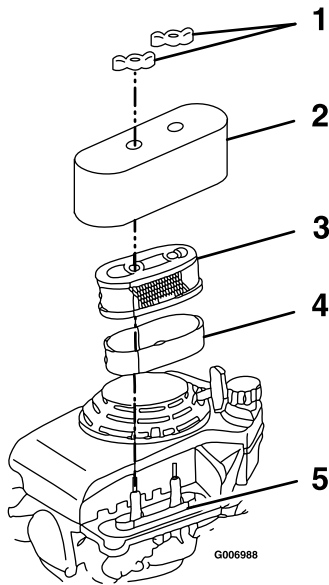

Figure 29

- |                  |                 |
|------------------|-----------------|
| 1. Wing nuts     | 4. Foam element |
| 2. Cover         | 5. Base         |
| 3. Paper element |                 |

4. Remove the cover.

**Note:** Be careful to prevent dirt and debris from falling into the base.

5. Remove the foam and paper elements from the base.
6. Remove the foam element from the paper element.
7. Inspect the foam and paper elements, and replace them if they are damaged or excessively dirty.
8. Tap the paper element on a hard surface several times or use compressed air not exceeding 30 psi (207 kPa) through the filter from the wire screen side to remove any excess dirt. If the paper element is excessively dirty, replace it.

**Note:** Never try to brush dirt off the paper element; brushing forces the dirt into the fibers.

9. Clean the foam element in warm, soapy water or in a **nonflammable** solvent.
10. Rinse and dry the foam element thoroughly.
11. Dip the foam element in clean engine oil, then squeeze out the excess oil.

**Note:** Excess oil in the foam element restricts the air flow through the element and may reach the paper filter and clog it.

12. Wipe dirt from the base and the cover with a moist rag.

**Note:** Be careful to prevent dirt and debris from entering the air duct leading to the carburetor.

13. Install the air cleaner elements and ensure that they are properly positioned.
14. Securely install the cover with the two wing nuts.

## Change Engine Oil

**Service Interval: After the first 5 hours**

**Every 50 hours (May need more often under severe conditions.)**

1. Run the engine to warm the engine oil.

**Note:** Warm oil flows better and carries more contaminants.

### **⚠ WARNING**

**Oil may be hot after engine has been run. Contact with hot oil can cause severe personal injury.**

**Avoid contacting the hot engine oil when you drain it.**

2. Stop engine, wait for all moving parts to stop.
3. Disconnect the wire from the spark plug.
4. Drain the gasoline from the fuel tank. Refer to **Emptying the Fuel Tank and Cleaning the Fuel Filter** section.
5. Place a suitable drain pan under the dipstick/oil drain.
6. Clean around the dipstick.
7. Remove the dipstick by rotating the cap counterclockwise and pulling it out.
8. Raise the left side of the lawn mower to drain the oil from the dipstick fill tube into the drain pan.
9. After draining the oil, return the lawn mower to the operating position.
10. Fill the crankcase with fresh oil to the upper limit mark on the dipstick.
11. Insert the dipstick into the filler neck and rotate the cap clockwise until it is tight.
12. Wipe up any spilled oil.
13. Connect the wire to the spark plug.
14. Recycle the used oil according to local codes.

## Change Oil Filter (EC21KA, EC21KABBC, EC21KAX, EC21KAY, EC21KABBCX, EC21KABBCY, EC21KACA, and EC21KABBCCA)

**Service Interval: Every 100 hours**

1. Run the engine to warm the oil.
2. Stop the engine and wait for all moving parts to stop.
3. Disconnect the wire from the spark plug.
4. Drain the engine oil.
5. Place a rag under the oil filter to catch any oil that may leak out as you remove the filter.
6. Remove the oil filter.
7. Use your finger to coat the gasket on the new filter with clean engine oil (see Figure 30).

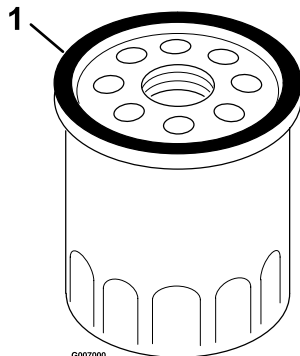

Figure 30

1. Gasket

8. Install the new filter and hand tighten it 2/3 turn only.
9. Fill the crankcase to the Full line on the dipstick with fresh oil.
10. Connect the wire to the spark plug.
11. Run the engine for about 3 minutes.
12. Stop the engine, wait for all moving parts to stop, and check for oil leakage around the filter.
13. Add oil to compensate for the oil in the oil filter.
14. Recycle the used oil filter according to local codes.

## Check Condition Of Belt (Self-Propelled Units Only)

**Service Interval: Every 40 hours**

1. Stop engine, wait for all moving parts to stop.
2. Remove the belt cover to the lawn mower housing.
3. Check the belt for cracks, frayed edges, burn marks or any other damage.
4. Replace the damaged belt.

## Check Spark Plugs

**Service Interval: Every 100 hours**

1. Stop the engine and wait for all moving parts to stop.
2. Disconnect the wire from the spark plug (Figure 10 and Figure 11).
3. Clean around the spark plug.
4. Remove the spark plug from the cylinder head.

**Note:** Replace a cracked, fouled, or dirty spark plug. Do Not clean the electrodes because grit entering the cylinder can damage the engine.

5. Set the gap on the plug to 0.030 inch (0.76 mm) (Figure 31).

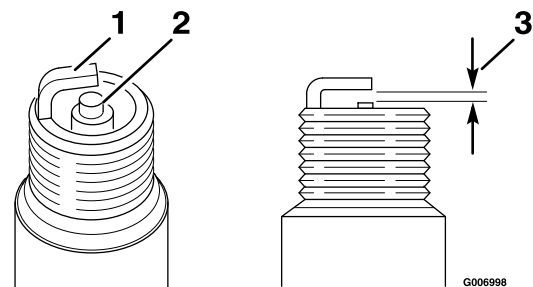

Figure 31

1. Side electrode
2. Center electrode insulator
3. Air gap—0.030 inch (0.76 mm)

6. Install the spark plug and the gasket seal.
7. Torque the plug to 17 ft-lb (23 N-m).
8. Connect the wire to the spark plug.

## Emptying the Fuel Tank and Cleaning the Fuel Filter

**Service Interval: Every 100 hours**

# Maintenance

The fuel filter (screen) element is located inside the fuel tank (if applicable).

**Note:** The EC21ASHN does not have a removable fuel tank.

1. Stop the engine and wait for it to cool down.  
**Note:** Drain gasoline for a cold engine only.
2. Disconnect the wire from the spark plug (Figure 11).
3. Close the fuel valve.
4. Disconnect the fuel line by loosening the tube clamp at the carburetor.
5. Open the fuel valve by turning the lever to the open position.
6. Drain the gasoline completely from the tank and fuel line into an approved fuel container.
7. Remove the fuel tank from the mower.
8. Close the fuel valve.
9. Pour a small amount of fuel in the fuel tank, move the fuel around in the tank, and pour it out into an approved fuel container.
10. Install the fuel tank and fuel line.

# Adjustments

**Note:** Wait for all moving parts to stop and remove spark plug wire before servicing, cleaning, or making any adjustments to the unit.

## Adjusting the Self-Propel Drive (Self-Propelled Units Only)

If the lawn mower does not self-propel or has a tendency to creep forward when the control bail is released, adjust the drive cable nuts as shown in Figure 33.

### **⚠ DANGER**

**Checking the operation of the mower with the belt cover removed will allow debris to be thrown in the operator's or bystander's direction and can result in serious personal injury or death.**

**Do Not operate the unit when cover is not in place.**

1. Stop the engine and wait for all moving parts to stop.
2. Remove the belt cover by pulling upward on the back of the cover to unsnap the front and back cover tabs. Remove any debris under the cover.

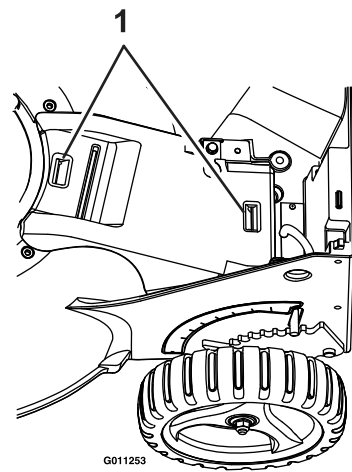

**Figure 32**

1. Belt cover tabs

3. If the lawn mower does not self-propel with bail engaged, tighten the belt by turning the drive

cable nuts clockwise. To maximize belt life, Do Not overtighten the belt.

If the lawn mower creeps forward without the bail engaged, loosen the belt by turning the drive cable nuts counterclockwise.

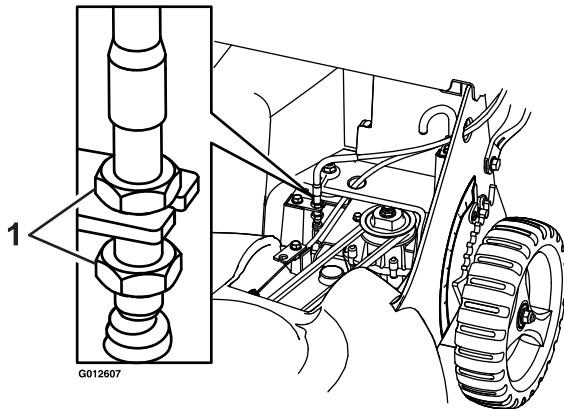

**Figure 33**

1. Adjustment of drive cable nuts

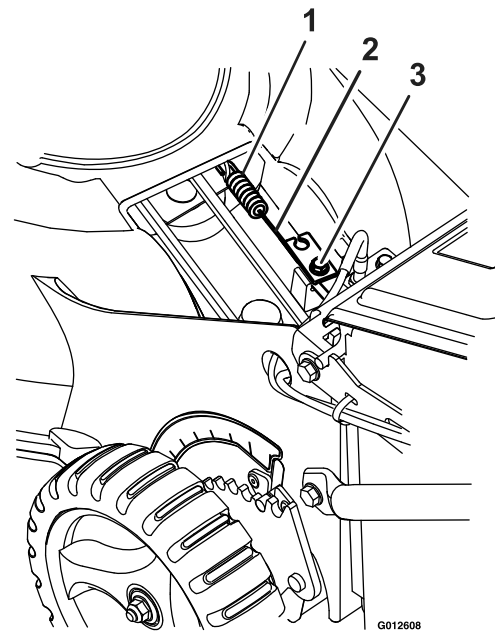

**Figure 34**

1. Spring
2. Cable conduit
3. Cable clamp screw

4. Reinstall the belt cover by pushing down on the rear first and then snapping the front onto the mower housing.
5. Check the operation for desired drive control.
6. Repeat steps 2 through 5 as necessary for further adjustment.

**Note:** Adjustment to obtain desired ground speed at full bail travel may be made in order to accommodate slower speeds.

## Adjusting the Blade Brake Cable (Blade Brake Clutch Units Only)

Adjust whenever a new blade brake cable assembly is installed or if the blade control lock lever does not operate properly.

1. Stop the engine and wait for all moving parts to stop.
2. Disconnect the wire from the spark plug.
3. Remove the belt cover by pulling upward on the back of the cover to unsnap the front and back cover tabs (see Figure 32). Remove any debris under the cover.
4. Loosen the cable clamp screw until the cable conduit slides (see Figure 34).

5. Pull the cable until there is approximately 1/8 inch in slack. Do Not put tension on the spring.
6. Tighten the screw to lock the adjustment in place.
7. Reinstall the belt cover by pushing down on the rear first and then snapping the front onto the mower housing.
8. Connect the wire to the spark plug.
9. Check the operation of the blade control lock lever (see Figure 13). The lever must reset itself to lock out the blade control bail. If it does not, repeat steps 4 through 8.
10. Perform the “Checking the Blade Brake Clutch (Blade Brake Clutch Units Only)” procedure in Operation.

## Cleaning

### Clean Grass Build-Up Under Deck

#### Service Interval: Before each use or daily

1. Stop engine, wait for all moving parts to stop, and remove spark plug wire.
2. To ensure the best performance, keep the underside of the lawn mower housing clean.

#### ⚠ CAUTION

The mower may dislodge material from under the mower housing.

- Wear eye protection.
- Stay in the operating position (behind the handle).
- Do Not allow bystanders in the area.

#### Washing Method

1. Position the lawn mower on a flat concrete or asphalt surface near a garden hose.
2. Start the engine.
3. Hold the running garden hose at handle level and direct the water to flow on the ground just in front of the right rear tire (Figure 35).

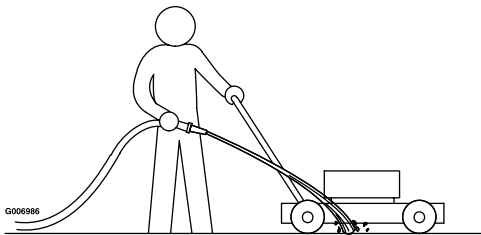

Figure 35

4. Engage the blade.

**Note:** The blade will draw in water and wash out clippings. Let the water run until you no longer see clippings being washed out from under the housing.

5. Disengage the blade, stop the engine and wait for all moving parts to stop.

6. Turn off the water.
7. Start the lawn mower, engage the blade, and let the lawn mower run for a few minutes to dry out its components.

#### Scraping Method

If washing does not remove all debris from under the lawn mower, scrape it clean.

1. Disconnect the wire from the spark plug.
2. Drain the fuel from the fuel tank. Refer to **Emptying the Fuel Tank and Cleaning the Fuel Filter** section.
3. Tip the lawn mower onto its right side.
4. Remove the dirt and grass clippings with a hardwood scraper. Avoid burrs and sharp edges.
5. Turn the lawn mower upright.
6. Fill the fuel tank.
7. Connect the wire to the spark plug.

### Cleaning the Discharge Tunnel and Plug

#### Service Interval: Before each use or daily

Always be sure that the discharge tunnel door closes securely when you release the handle. If the debris prevents the discharge door from closing securely, clean the inside of the discharge tunnel and the door thoroughly.

#### ⚠ WARNING

Grass clippings and other objects can be thrown from an open discharge tunnel. Thrown objects can cause serious injury or kill the operator or bystanders.

Never start or operate the lawn mower unless one of the following is true:

- The discharge tunnel plug is locked securely in the discharge tunnel.
- The grass bag is locked in place.
- The optional rear discharge chute is locked in place.
- The discharge tunnel door is closed.



## Cleaning Under the Belt Cover (Self-Propelled Units Only)

**Service Interval: Every 50 hours**

1. Stop the engine and wait for all moving parts to stop.
2. Disconnect the wire from the spark plug (see Figure 10 and Figure 11).
3. Pull upward on the back of the cover to unsnap the front and back cover tabs (see Figure 32).
4. Lift off the cover and brush out all the debris around the belt area.
5. Install the belt cover by pushing down on the rear first and then snapping the front onto the mower housing.
6. Connect the wire to the spark plug.

## Cleaning the Blade Brake Clutch Shield (Blade Brake Clutch Units Only)

**Service Interval: Every 50 hours**

1. Stop the engine and wait for all moving parts to stop.
2. Disconnect the wire from the spark plug (see Figure 10 and Figure 11).
3. Drain the gasoline from the fuel tank. Refer to **Emptying the Fuel Tank and Cleaning the Fuel Filter** section.
4. Tip the lawn mower onto its right side (air filter up).
5. Remove the blade nuts and the blade (see Figure 25).

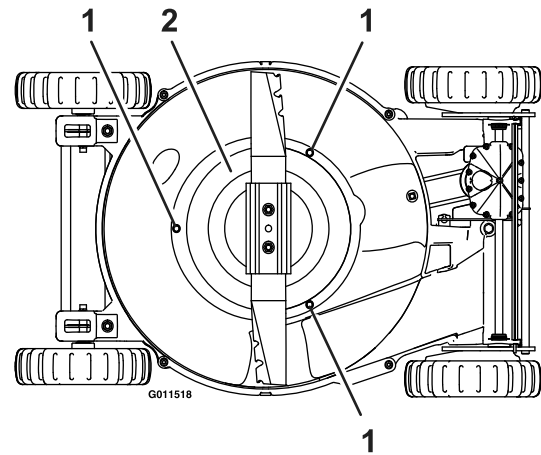

**Figure 36**

1. Screws
2. BBC Shield

6. Remove the three screws holding the BBC shield onto the unit (see Figure 36).
7. Remove the BBC shield and brush or blow all the debris from under the shield and around the BBC system.
8. Install the BBC shield. Tighten the screws to secure the BBC shield to the deck.
9. Install the blade and the two blade nuts.
10. Turn the lawn mower upright.
11. Connect the wire to the spark plug.

## Cleaning Under the Cover Plate (Non-Blade Brake Clutch Units Only)

**Service Interval: Every 50 hours**

1. Stop the engine and wait for all moving parts to stop.
2. Disconnect the wire from the spark plug (see Figure 10 and Figure 11).
3. Drain the gasoline from the fuel tank. Refer to **Emptying the Fuel Tank and Cleaning the Fuel Filter** section.
4. Tip the lawn mower onto its right side (air filter up).
5. Remove the blade bolt, blade support, and the blade (see Figure 25).

# Maintenance

---

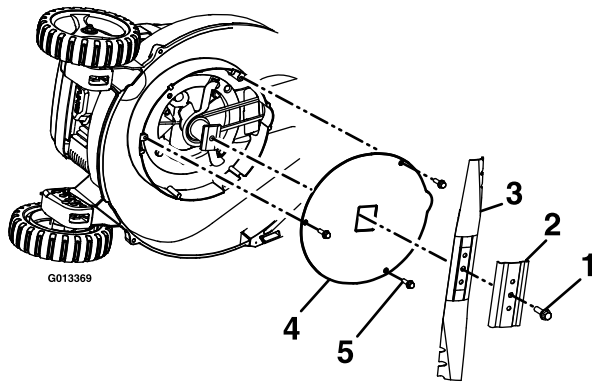

**Figure 37**

- |                  |                |
|------------------|----------------|
| 1. Blade bolt    | 4. Cover plate |
| 2. Blade support | 5. Screw       |
| 3. Blade         |                |

- 
6. Remove the three screws holding the cover plate onto the unit (see Figure 37).
  7. Remove the cover plate and brush or blow all the debris from under the plate.
  8. Reinstall the cover plate and torque the screws to 35-45 ft-lb (47-61 N-m).
  9. Install the blade, blade support, and the blade bolt.
  10. Turn the lawn mower upright.
  11. Connect the wire to the spark plug.

## Waste Disposal

### Motor Oil Disposal

Engine oil and hydraulic oil are both pollutants to the environment. Dispose of used oil at a certified recycling center or according to your state and local regulations.

# Storage

## Preparing the Fuel System

To prepare the lawn mower for off season storage, perform the recommended maintenance procedures.

Store the lawn mower in a cool, clean, dry place. Cover the lawn mower to keep it clean and protected.

### WARNING

Gasoline can vaporize if you store it over long periods of time. Gasoline vapors can explode if they come into contact with an open flame.

- Do Not store gasoline over long periods of time.
- Do Not store the lawn mower with gasoline in the fuel tank or the carburetor in an enclosure with an open flame. (For example, a furnace or a water heater pilot light.)
- Allow the engine to cool before storing it in any enclosure.

Empty the fuel tank when mowing the last time before storing the lawn mower.

1. Run the lawn mower until the engine stops from running out of fuel.
2. Prime the engine and start it again.
3. Allow the engine to run until it stops. When you can no longer start the engine it is sufficiently dry.

## Preparing the Engine

1. While the engine is still warm, change the oil from the crankcase. Refer to **Changing the Engine Oil** section in Maintenance.
2. Remove the spark plug.
3. Using an oil can, add about one tablespoon of oil to the crankcase through the spark plug hole.
4. Slowly rotate the engine several times, using the starter rope, to distribute the oil.
5. Install the spark plug but **Do Not** connect the wire to the spark plug.

## General Storage Information

1. Clean the lawn mower housing. Refer to **Cleaning the Underside of the Lawn Mower Housing** section in Cleaning.
2. Clean any dirt and chaff from the cylinder, cylinder head fins, and blower housing.
3. Remove grass clippings, dirt, and grime from the external parts of the engine, the shrouding, and the top of the lawn mower housing.
4. Clean the BBC shield. Refer to **Cleaning the Blade Brake Clutch Shield** section in Cleaning.
5. Check the condition of the blade. Refer to **Maintaining the Blade** section in the Maintenance.
6. Service the air filter. Refer to **Servicing the Air Filter** in Maintenance.
7. Tighten all nuts, bolts, and screws.
8. Touch up all rusted or chipped paint surfaces with paint available from an Authorized Service Dealer.

## Removing the Lawn Mower from Storage

1. Check and tighten all fasteners.
2. Remove the spark plug and spin the engine rapidly by pulling the starter rope to blow excess oil from the cylinder.
3. Clean the spark plug or replace it if it is cracked, broken, or if the electrodes are worn.
4. Install the spark plug and torque it to 17 ft-lb (23 N-m).
5. Perform any needed maintenance procedures.
6. Fill the fuel in the fuel tank with fresh gasoline.
7. Check the engine oil level.
8. Connect the wire to the spark plug.

## Troubleshooting

**Important:** It is essential that all operator safety mechanisms be connected and in proper operating condition prior to mower use.

When a problem occurs, Do Not overlook the simple causes. For example: starting problems could be caused by an empty fuel tank.

The following table lists some of the common causes of trouble. If a problem continues, contact an Authorized Service Dealer.

Problem	Possible Cause	Corrective Action
Engine will not start, starts hard, or fails to keep running.	<ol style="list-style-type: none"> <li>1. Fuel tank is empty.</li> <li>2. Fuel shut-off valve is closed.</li> <li>3. The throttle lever is not in the correct position.</li> <li>4. Dirt, water, or stale fuel is in the fuel system.</li> <li>5. Faulty spark plug.</li> <li>6. Spark plug wire is not connected.</li> </ol>	<ol style="list-style-type: none"> <li>1. Fill the fuel tank.</li> <li>2. Open the fuel shut-off valve.</li> <li>3. Move the throttle lever to the Choke position.</li> <li>4. Contact an Authorized Service Dealer.</li> <li>5. Clean, adjust or replace spark plug.</li> <li>6. Check the spark plug wire connection.</li> </ol>
Engine loses power.	<ol style="list-style-type: none"> <li>1. Air cleaner is dirty.</li> <li>2. Oil level in the crankcase is low.</li> <li>3. Vent hole in the fuel cap is plugged.</li> <li>4. Dirt in fuel filter.</li> <li>5. Dirt, water, or stale fuel is in the fuel system.</li> <li>6. The underside of the lawn mower deck contains clippings and debris</li> </ol>	<ol style="list-style-type: none"> <li>1. Clean or replace the air cleaner element.</li> <li>2. Add oil to the crankcase.</li> <li>3. Clean or replace the fuel cap.</li> <li>4. Replace the fuel filter.</li> <li>5. Contact an Authorized Service Dealer.</li> <li>6. Clean the underside of the lawn mower deck.</li> </ol>
Engine runs rough.	<ol style="list-style-type: none"> <li>1. The wire is not connected to the spark plug.</li> <li>2. Faulty spark plug.</li> <li>3. The throttle lever is not in the Fast position.</li> <li>4. The air filter element is dirty and is restricting the air flow.</li> </ol>	<ol style="list-style-type: none"> <li>1. Connect the wire to the spark plug.</li> <li>2. Clean, adjust or replace spark plug.</li> <li>3. Move the throttle lever to the Fast position.</li> <li>4. Clean the air filter pre-cleaner and/or replace the paper air filter.</li> </ol>
Lawn mower or engine vibrates excessively.	<ol style="list-style-type: none"> <li>1. The blade is bent or is out of balance.</li> <li>2. The blade mounting bolt is loose.</li> <li>3. The underside of the lawn mower deck contains clippings and debris.</li> <li>4. The engine mounting bolts are loose.</li> </ol>	<ol style="list-style-type: none"> <li>1. Balance the blade. If the blade is bent, replace it.</li> <li>2. Tighten the blade mounting bolt.</li> <li>3. Clean the underside of the lawn mower deck.</li> <li>4. Tighten the engine mounting bolts.</li> </ol>
Uneven cutting pattern.	<ol style="list-style-type: none"> <li>1. All four wheels are not at the same height.</li> <li>2. The blade is dull.</li> <li>3. Mowing in the same pattern repeatedly.</li> <li>4. The underside of the lawn mower deck contains clippings and debris.</li> </ol>	<ol style="list-style-type: none"> <li>1. Place all four wheels at the same height.</li> <li>2. Sharpen and balance the blade.</li> <li>3. Change the mowing pattern.</li> <li>4. Clean the underside of the lawn mower deck.</li> </ol>
Discharge chute plugs	<ol style="list-style-type: none"> <li>1. The throttle lever is not in the Fast position.</li> <li>2. Cutting too much grass in one pass</li> <li>3. Mowing too fast.</li> <li>4. The grass is wet.</li> <li>5. The underside of the lawn mower deck contains clippings and debris.</li> </ol>	<ol style="list-style-type: none"> <li>1. Move the throttle lever to the Fast position.</li> <li>2. Raise the cutting height. If necessary, cut second time at lower cutting height.</li> <li>3. Slow down.</li> <li>4. Allow the grass to dry before mowing.</li> <li>5. Clean the underside of the lawn mower deck.</li> </ol>

# Troubleshooting

<b>Problem</b>	<b>Possible Cause</b>	<b>Corrective Action</b>
Lawn mower does not self-propel (Self-Propelled Units Only)	<ol style="list-style-type: none"><li>1. The self-propel drive cable is out of adjustment or is damaged.</li><li>2. There is debris under the belt cover.</li></ol>	<ol style="list-style-type: none"><li>1. Adjust the self-propel drive cable. Replace the cable if necessary.</li><li>2. Clean the debris from under the belt cover.</li></ol>
Difficult to pull lawnmower rearward (Self-Propelled Units Only).	<ol style="list-style-type: none"><li>1. Transmission is locked.</li></ol>	<ol style="list-style-type: none"><li>1. Push mower forward to disengage the transmission and then pull rearward.</li></ol>

# Exmark Commercial Turf Equipment 1 Year Limited Warranty

## Conditions and Products Covered

Exmark Mfg. Co. Inc. and its affiliate, Exmark Warranty Company, pursuant to an agreement between them, jointly warrant on the terms and conditions herein, that we will repair, replace or adjust any part on these products and found by us (in the exercise of our reasonable discretion) to be defective in factory materials or workmanship for a period of one year.

This warranty applies to Exmark commercial turf equipment sold in the U.S. or Canada. This warranty may only be assigned or transferred to a second (or third) owner by an authorized Exmark dealer. The warranty period commences upon the date of the original retail purchase.

### Warranty Exceptions

- Bags, Belts and Tires
- Engine

### Warranty Period

90 days  
2 years\*

\* The Engine warranty is covered by the engine manufacturer. Please refer to the engine manufacturer's warranty statement that is included in the literature packet.

This warranty only includes the cost of parts and labor.

## Items and Conditions Not Covered

This warranty does not cover the following:

- Pickup and delivery charges to and from any authorized Exmark Service Dealer.
- Any damage or deterioration due to normal use, wear and tear, or exposure.
- Cost of regular maintenance service or parts, such as filters, fuel, lubricants, tune-up parts, and adjustments.
- Any product or part which has been altered or misused or required replacement or repair due to normal wear, accidents, or lack of proper maintenance.
- Any repairs necessary due to use of parts, accessories or supplies, including gasoline, oil or lubricants, incompatible with the turf equipment or other than as recommended in the operator's manual or other operational instructions provided by Exmark.

There are no other express warranties except for engine and special emission system coverage.

All warranty work must be performed by an authorized Exmark Service Dealer using Exmark approved replacement parts.

## Instructions for Obtaining Warranty Service

The product must be registered with original proof of purchase by an Exmark Service Dealer before obtaining any warranty service.

Contact any Exmark Service Dealer to arrange service at their dealership. To locate a dealer convenient to you, access our website at [www.exmark.com](http://www.exmark.com). U.S. or Canada customers may also call 402-223-6375.

If for any reason you are dissatisfied with the Service Dealer's analysis or with the assistance provided, contact us at:

Exmark Customer Service Department  
The Exmark Warranty Company  
2101 Ashland Avenue  
Beatrice, NE 68310  
402-223-6375 or  
[service@exmark.com](mailto:service@exmark.com)

## Owner's Responsibilities

If your product requires warranty service it must be returned to an authorized Exmark service dealer within the warranty period. This warranty extends only to turf equipment operated under normal conditions. You must read the operator's manual. You must also properly service and maintain your Exmark product as described in the operator's manual. Such routine maintenance, whether performed by a dealer or by you, is at your expense.

## General Conditions

The sole liability of Exmark and Exmark Warranty Company with respect to this warranty shall be repair or replacement of defective components as set forth herein. **Neither Exmark nor Exmark Warranty Company shall be liable for any incidental or consequential loss or damage.**

Such damages include but are not limited to:

- Expenses related to gasoline, oil or lubricants.
- Travel time, overtime, after hours time or other extraordinary repair charges or charges relating to repairs or replacements outside of normal business hours at the place of business of the authorized Exmark Service Dealer.
- Rental of like or similar replacement equipment during the period of any warranty, repair or replacement work.
- Any telephone or telegram charges or travel charges.
- Loss or damage to person or property other than that covered by the terms of this warranty.
- Any claims for lost revenue, lost profit or additional cost as a result of a claim of breach of warranty.
- Attorney's fees.

No Claim of breach of warranty shall be cause for cancellation or rescission of the contract of sale of any Exmark mower.

**All implied warranties of merchantability (that the product is fit for ordinary use) and fitness for use (that the product is fit for a particular purpose) are limited to the duration of the express warranty.**

**Some states do not allow exclusions of incidental or consequential damages, or limitations on how long an implied warranty lasts, so the above exclusions and limitations may not apply to you.**

This warranty gives you specific legal rights, and you may also have other rights which vary from state to state.



## SEE EXMARK'S COMPLETE LINE OF ACCESSORIES AND OPTIONS

### MID-MOUNT RIDING ACCESSORIES AND OPTIONS

CUSTOM RIDE SEAT SUSPENSION SYSTEM	OPERATOR CONTROLLED DISCHARGE
FULL SUSPENSION SEAT	ROLL OVER PROTECTION SYSTEM (ROPS)
DECK LIFT ASSIST KIT	SUN SHADE
HITCH KIT	TRASH CONTAINER
LIGHT KIT	TURF STRIPER
12V POWER PORT	ULTRA VAC COLLECTION SYSTEM
MICRO-MULCH SYSTEM	ULTRA VAC QUICK DISPOSAL SYSTEM

### OUT-FRONT RIDING ACCESSORIES AND OPTIONS

CUSTOM RIDE SEAT SUSPENSION SYSTEM	SNOW BLADE
DUAL-TAIL WHEEL	SNOWBLOWER
FLOOR PAN EXTENDER	SUN SHADE
HITCH KIT	TRASH CONTAINER
LIGHT KIT	ULTRA VAC COLLECTION SYSTEM
MICRO-MULCH SYSTEM	ULTRA VAC QUICK DISPOSAL SYSTEM
ROLL OVER PROTECTION SYSTEM (ROPS)	WEATHER CAB

### WALK-BEHIND ACCESSORIES AND OPTIONS

GRASS CATCHER	TURF STRIPER
MICRO-MULCH SYSTEM	STANDON

Place Model No. and Serial No.  
Label Here (Included in the Literature  
Pack) or Fill in Below

Model No. \_\_\_\_\_

Serial No. \_\_\_\_\_

Date Purchased \_\_\_\_\_

Engine Model No. and Spec. No. \_\_\_\_\_

Engine Serial No. (E/No) \_\_\_\_\_

© 2010 Exmark Mfg. Co., Inc.  
Industrial Park Box 808  
Beatrice, NE 68310  
All Rights Reserved

Part No. 4500-674 Rev. A  
(402) 223-6300  
Fax (402) 223-5489  
Printed in the USA

