



Operator's Manual

8000 SERIES (Diesel Version) **ZTR® MOWERS**

2001

IMPORTANT - READ CAREFULLY

The Dixon[®] ZTR[®] Mower is both easy and fun to operate. However, any power mower must be operated properly to be safe. It is not a toy or a recreational vehicle. Before you start to use the mower, read the operator's manual carefully and become completely familiar with the controls.

The information in this operator's manual applies to all Dixon[®] ZTR[®] 8000 Series Diesel Version Commercial Mowers. Your Dixon dealer will gladly answer any questions.

See your dealer for warranty service, parts and repairs.



DIXON INDUSTRIES, INC.
A BLOUNT International Inc. Co.
PO BOX 1569
COFFEYVILLE KS 67337 0945
316 251 2000

BLOUNT

INDEX

SAFETY	Pages 4-9
WARRANTY POLICY	Page 10
SPECIFICATIONS	Page 11
CONTROLS	Pages 12-15
OPERATION INSTRUCTIONS	Pages 16-20
CARE AND MAINTENANCE	Pages 21-30
STANDARD SERVICE PARTS LIST	Page 31
TROUBLESHOOTING	Pages 32-33

SAFETY

***RIDING LAWNMOWERS, IF IMPROPERLY OPERATED,
CAN CAUSE SERIOUS INJURY OR DEATH***

The most common causes of injury to the operator or bystander...

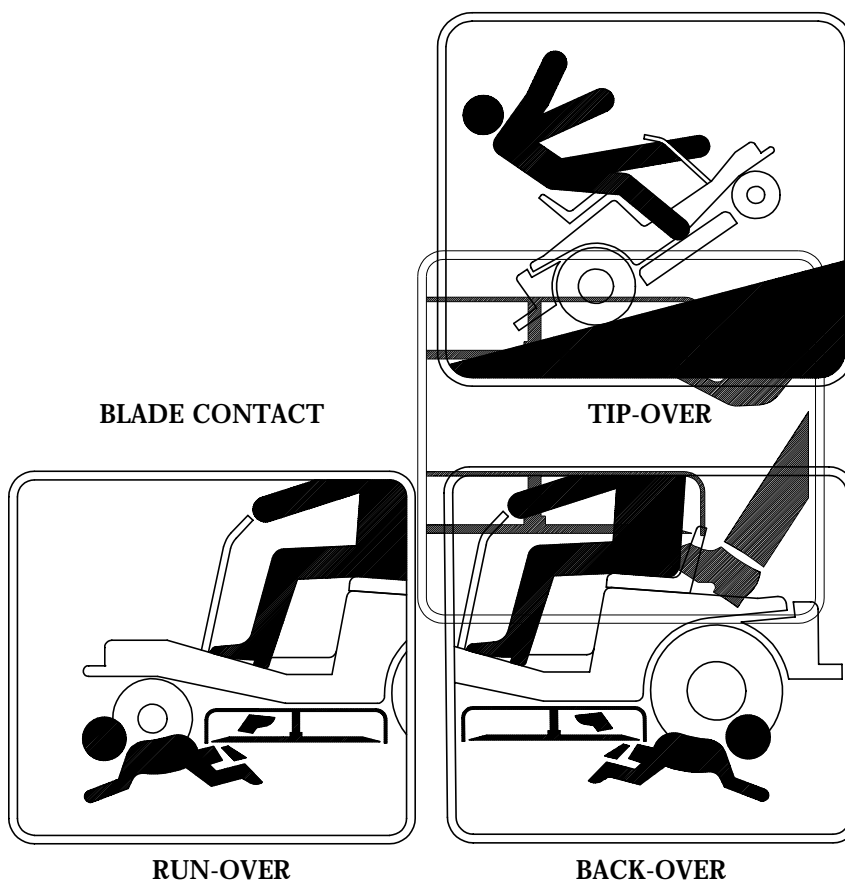

...read and understand this manual to prevent injuries.

SAFETY



Safety Alert Symbol

When you see this symbol,
BE ALERT to the potential for injury.

Follow recommended safety precautions and safe operating practices.



Danger

indicates an imminently hazardous situation which, if not avoided, will result in death or serious injury.



Warning

indicates a potentially hazardous situation which, if not avoided, could result in death or serious injury.



Caution

indicates a potentially hazardous situation which, if not avoided, may result in minor or moderate injury. It may also be used to alert against unsafe practices.

 **SAFETY**

Failure to observe the following safety instructions could result in serious injury or death.

GENERAL OPERATION:

- Read, understand, and follow all instructions in the manual and on the mower before starting.
- Only allow responsible adults, who are familiar with the instructions, to operate the mower.
- Clear the area of objects such as rocks, toys, wire, etc., which could be picked up and thrown by the blade.
- Be sure the area is clear of other people before mowing. Stop mower if anyone enters the area.
- Never carry passengers.
- Do not mow in reverse unless absolutely necessary. Always look down and behind before and while backing.
- Be aware of the mower discharge direction and do not point it at anyone. Do not operate the mower without either the entire grass catcher or the deflector in place.
- Slow down before turning.
- Never leave a running mower unattended. Always turn off blades, set parking brake, stop engine, and remove key before dismounting.
- Turn off blades when not mowing.
- Stop engine before removing grass catcher or unclogging chute.
- Mow only in daylight or good artificial light.
- Do not operate the mower while under the influence of alcohol or drugs.
- Watch for traffic when operating near or crossing roadways.
- Use extra care when loading or unloading the mower into a trailer or truck. Do not ride the mower when loading & unloading.
- Always wear safety goggles or safety glasses with side shields when operating mower.
- Data indicates that operators, age 60 years and above, are involved in a large percentage of riding mower-related injuries. These operators should evaluate their ability to operate the riding mower safely enough to protect themselves and others from serious injury.
- Follow the manufacturer's recommendation for wheel weights or counterweights.
- Maintain or replace safety and instruction labels, as necessary.



WARNING:

The engine exhaust from this product contains chemicals known to the State of California to cause cancer, birth defects or other reproductive harm.

 **SAFETY*****SLOPE OPERATION:***

Slopes are a major factor related to loss-of-control and tip-over accidents, which can result in severe injury or death.

All slopes require extra caution.

If you cannot back up the slope or if you feel uneasy on it, do not mow it!

DO

Mow across the slope with your Dixon ZTR - never up or down.

Remove obstacles such as rocks, tree limbs, etc.

Watch for holes, ruts or bumps. Uneven terrain could overturn the mower. Tall grass can hide obstacles.

Use slow speed. Tires may lose traction on slopes even though the brakes are functioning properly.

Use extra care with grass catchers or other attachments. These can change the stability of the mower.

Keep all movement on the slopes slow and gradual. Do not make sudden changes in speed or direction.

Avoid starting or stopping on a slope. If tires lose traction, disengage the blades and proceed slowly down the slope.

If front wheels lift off the ground, pull the levers back to stabilize the mower.

DO NOT

Do not turn on slopes unless necessary, and then, turn slowly and gradually downhill, if possible.

Do not mow near drop-offs, ditches, or embankments. The mower could suddenly turn over if a wheel is over the edge of a cliff or ditch, or if an edge caves in.

Do not mow on wet grass. Reduced traction could cause sliding.

Do not try to stabilize the mower by putting your foot on the ground.

Do not use grass catcher on steep slopes.

 **SAFETY*****CHILDREN:***

Tragic accidents can occur if the operator is not alert to the presence of children.

Children are attracted to lawn mowers and the mowing activity.

NEVER assume children will stay where they were last seen.

Be alert to avoid accidents.

- **Keep children out of the mowing area and under the watchful care of another responsible adult.**
- **Be alert and turn mower off if a child enters the area.**
- **Before and during backing, look behind and DOWN for small children.**
- **Never carry children. They may fall off and be seriously injured or interfere with safe mower operation.**
- **Never allow children to operate the mower.**
- **Use extra care when approaching blind corners, shrubs, trees, or other objects that may obscure vision.**

 **SAFETY*****SERVICE:***

- Use extra care in handling gasoline and other fuels. They are flammable and vapors are explosive.

Use only an approved container.

Never remove fuel cap or add fuel with the engine running. Allow engine to cool before refueling.

Do not smoke while refueling.

Never refuel the mower indoors.

Never store the mower or fuel container inside a building where there is an open flame.

If fuel is spilled on clothing, change clothing immediately.

To prevent fire and explosion caused by static electricity:

Never fill containers inside a vehicle or on a truck or trailer bed with a plastic liner. Always place containers on the ground away from your vehicle before filling.

When practical, remove fuel-powered equipment from the truck or trailer and refuel it on the ground. If this is not possible, then refuel such equipment on a trailer with a portable container, rather than from a fuel dispenser nozzle.

If a fuel dispenser nozzle must be used, keep the nozzle in contact with the rim of the fuel tank or container opening at all times until fueling is complete. Do not use a nozzle lock-open device.

- Never run a mower inside a closed area. The exhaust fumes are toxic.
- Keep nuts and bolts tight, especially blade attachment bolts, and keep equipment in good condition.
- Never tamper with safety devices. Check their proper operation regularly.
- Keep mower free of grass, leaves, or other debris buildup. Clean up oil or fuel spillage. Allow mower to cool before storing.
- Stop and inspect the equipment if you strike an object. Repair, if necessary, before restarting.
- Never make adjustments or repairs with the engine running unless otherwise specified.
- Grass catcher components are subject to wear, damage, and deterioration, which could expose moving parts or allow objects to be thrown. Frequently check components and replace with original equipment parts, when necessary.
- Mower blades are sharp and can cut. Wrap the blade(s) or wear gloves, and use extra caution when servicing them.
- Batteries contain sulfuric acid. To prevent burns avoid contact with skin, eyes and clothing. To prevent a fire or explosion keep sparks and open flames away from battery.
- Before disconnecting the negative (-) ground cable, make sure all switches are OFF.

DIXON INDUSTRIES, INC.
a BLOUNT company
AIRPORT INDUSTRIAL PARK
PO BOX 1569
COFFEYVILLE KS 67337 0945
316 251 2000
FAX 316 251 4117



DIXON LIMITED WARRANTY POLICY - COMMERCIAL MODELS

8000 Series

WARRANTY: Home Owner Application: This Dixon Warranty term is for a period of three (3) years from date of purchase. **Commercial Application:** Dixon mowers used for commercial application are warranted for one (1) year from the date of purchase or 750 hours whichever comes first. Commercial use is specified as use other than, or in addition to, mowing at owner's primary place of residence.

DIXON ZTR MOWERS ARE WARRANTED AGAINST DEFECTS IN MATERIALS AND WORKMANSHIP AND PROVIDES FOR REPLACEMENT OR REPAIR OF PARTS INCLUDING LABOR COSTS. THIS WARRANTY IS SUBJECT TO THE FOLLOWING CONDITIONS AND LIMITATIONS:

1. Warranty applies only to original retail purchaser of new and unused mowers and accessories.
2. All Dixon warranty must be accomplished by authorized Dixon dealers and in accordance with Dixon warranty policy and allowances. All warranty claims must be approved by Dixon Industries, Inc.
3. Battery warranty: Limited to 90 days from date of purchase.
4. Accessories Warranty (Grass Catchers, Snow Blades, Covers, etc.): Limited to 90 days from date of purchase.
5. Warranty does not apply to damage in transit or incidents of misuse, negligence, accidents, or alteration. The use of parts or components other than those supplied by Dixon Industries, Inc. **VOIDS ALL WARRANTY.**
6. The following items are not covered by this warranty policy:
 - (a) Pick up and delivery charges for transportation of mower to and from an authorized Dixon dealer's place of business.
 - (b) Routine maintenance or adjustments.
 - (c) Belts/cutting blades/Hydrostatic filters.
 - (d) Engines—All engines used on Dixon ZTR mowers are warranted by the individual engine manufacturer.
 - (e) Any costs or expense of providing substitute equipment while repair work is being performed on a warranted mower.
7. There is no other express warranty. Implied warranties, including those of merchantability and fitness for a particular purpose, are limited to the same duration of the express warranty, and to the extent permitted by law any and all implied warranties are excluded.

Blue/Customer Yellow/Dealer White/Dixon Ind.

WARRANTY VALIDATION: At the time of sale, selling dealer must review each portion of this warranty document, complete the information section below, secure customer's signature & send copy to Dixon Industries, Inc.

DATE OF PURCHASE _____ MODEL _____ S/N _____

Owner's Name _____

Dealership _____

Address _____

Address _____

Owner's Signature _____

Dealer's Signature _____

SPECIFICATIONS

8000 Series (Diesel Version)

CHASSIS:	<i>11 GA - rectangular tube, 7 GA reinforcement</i>
SEAT:	<i>Designed for operator comfort with padded back and arm rests. Seat is adjustable fore and aft. Mounted on operator suspension system with damper.</i>
MOWER DECK:	<i>2 Decks are available. Both decks are made of 10 GA fabricated welded construction with 1/4 " reinforcement plate. 3 blades combine for either a 60" or 72" cut width. Deep deck with discharge tunnel. Cut height approximately 1.5" to 6" via 10 position lift handle.</i>
BLADE DRIVE:	<i>"V" Belt with Electric clutch</i>
DRIVE SYSTEM:	<i>Each rear wheel is independently driven by a HydroGear BDP pump and White CE wheel motor.</i>
ENGINE:	<i>26 HP Briggs & Stratton Vanguard 950D, 3 cylinder in-line, water cooled, diesel, horizontal shaft, pressure feed lubrication with spin-on oil filter, fuel filter with primer pump and water separator, paper element with cyclone pre-cleaner.</i>
STARTING SYSTEM:	<i>Electric by keyswitch operation with safety interlock on parking brake, blade drive clutch and control levers.</i>
TIRES:	<i>Front 13-6.5x6 Rear 23-10.5x12</i>
RECOMMENDED TIRE PRESSURE:	<i>Front 16-20 lbs. Rear 8-14 lbs.</i>
CAPACITIES:	<i>Fuel - 11 gallons (approx) Hydrostat oil system - 4 quart with in-line 25 micron filter Hydrostat oil recommendation - SAE 20W50 motor oil Engine - 3.5 quart. CF/CF4 10W30 motor oil Coolant capacity - 2 gallons 50/50 mix</i>
DIMENSIONS:	<i>Width 73.5"(60" Deck), 85.5"(72" Deck) Height 54" Length 93" Weight 1330 lbs.(60" Deck), 1364 lbs.(72" Deck)</i>
NOTE:	<i>Additional information provided in service instructions under the individual component.</i>

SPECIFICATIONS SUBJECT TO CHANGE WITHOUT NOTICE

CONTROLS

CONTROL LEVERS

Note: For access to the seat move control levers to neutral position and swing them outward.

TO GO FORWARD:

From neutral position, gently push both control levers forward.
To increase speed, move levers further forward.

TO GO BACKWARD:

From neutral position, gently pull both control levers toward you.

TURNING:

Turning is controlled by moving one control lever slightly forward or rearward of the other.
To turn left, move left lever rearward of the right lever.
To turn right, move right lever rearward of the left lever.
To turn on mower's own axis (zero turning radius) stop and move one lever to reverse position and the other to forward position.

BRAKING:

To brake mower, move both levers in direction opposite of travel.

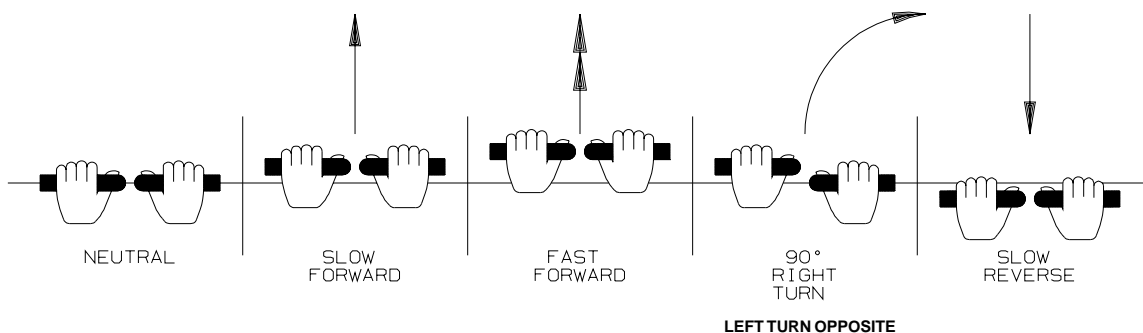

NOTE: *The pressure required to operate the mower is very light.*

CONTROLS

PARKING BRAKE:

A parking brake is located to the left of the seat.

Engine will kill if control levers are not in the outboard position when the parking brake is engaged.

To engage brake: pull up and back.

To disengage brake: push forward and down.

Note: The parking brake is not intended to be used as a service brake.

Note: Always set parking brake before dismounting. Release parking brake before moving mower.

Note: Engage parking brake before starting engine.

MOWER DECK LIFT:

The mower lift lever is extra long and has an assist spring for easy operation.

1. Grasp lever with right hand.
2. Depress thumb lever to release and move to desired position.
3. Release lever to lock into position.

Select cut height and insert pin into first hole below the lift lever. Ten holes are provided for a down stop so you can easily return from transport to desired cut height.

SEAT:

Fore & Aft: Move lever & slide seat fore & aft to desired position and release lever.

Seat Damper: A shock is located on the left side of the seat frame. Remove clip on the top and pull plunger up. Rotate shaft clockwise to make ride stiffer and counter-clockwise for a softer ride. Reattach to seat frame with clip.

Attention: Do not completely close off the damper. Closing off the damper causes it to become stiff making it difficult to fully extend the damper in order to open the adjustment. THE PRODUCT IS NOT DAMAGED. To restore adjustment follow these instructions: Hang the damper in the vertical position with the rod pointing down. Attach a load of approximately 15 pounds to the rod end of the damper. The load will slowly extend the damper. When fully extended the adjustment pin will be engaged. Turn the rod with the weight still hanging to open the adjustment.

CONTROLS

MOWER BLADE SWITCH:

To engage blades: pull up on switch.

To disengage blades: push down.

IGNITION SWITCH:

Turn to run position to energize glow plugs. Turn to start position when glow plug light turns off, then crank engine. Release when it starts.

For headlights - rotate switch one notch counter-clockwise from run.

NOTE: Remove key when mower is not in use.

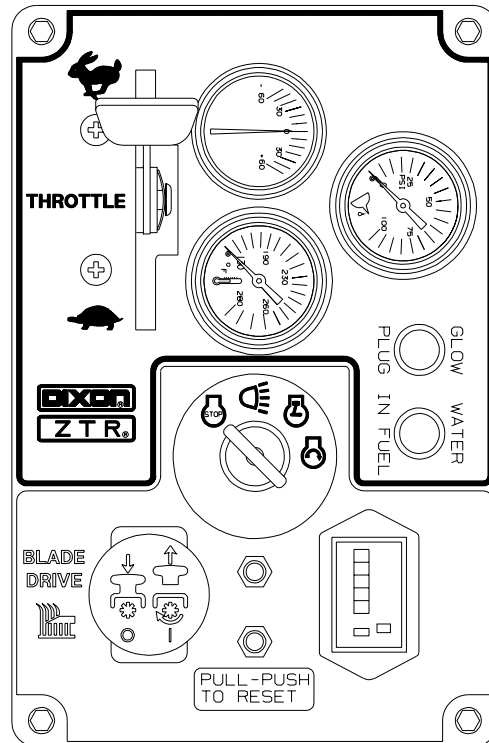

THROTTLE CONTROL LEVER

Located on control panel to operator's right. Controls engine speed.

While mowing, throttle control should be set to MAXIMUM or wide open setting to insure adequate cooling of the engine and to maintain mower deck blade speed.

CIRCUIT BREAKER:

If circuit breaker pops up it disconnects the power. Wait two minutes and push to reset. If it pops up again there is a short circuit. Stop and find fault or contact your dealer.

GLOW PLUG LIGHT:

Light is energized when ignition switch is first put in run position. Glow light cycle time is five seconds.

WATER IN FUEL LIGHT:

Light comes on when engine is running and fuel has water in it.

CONTROLS

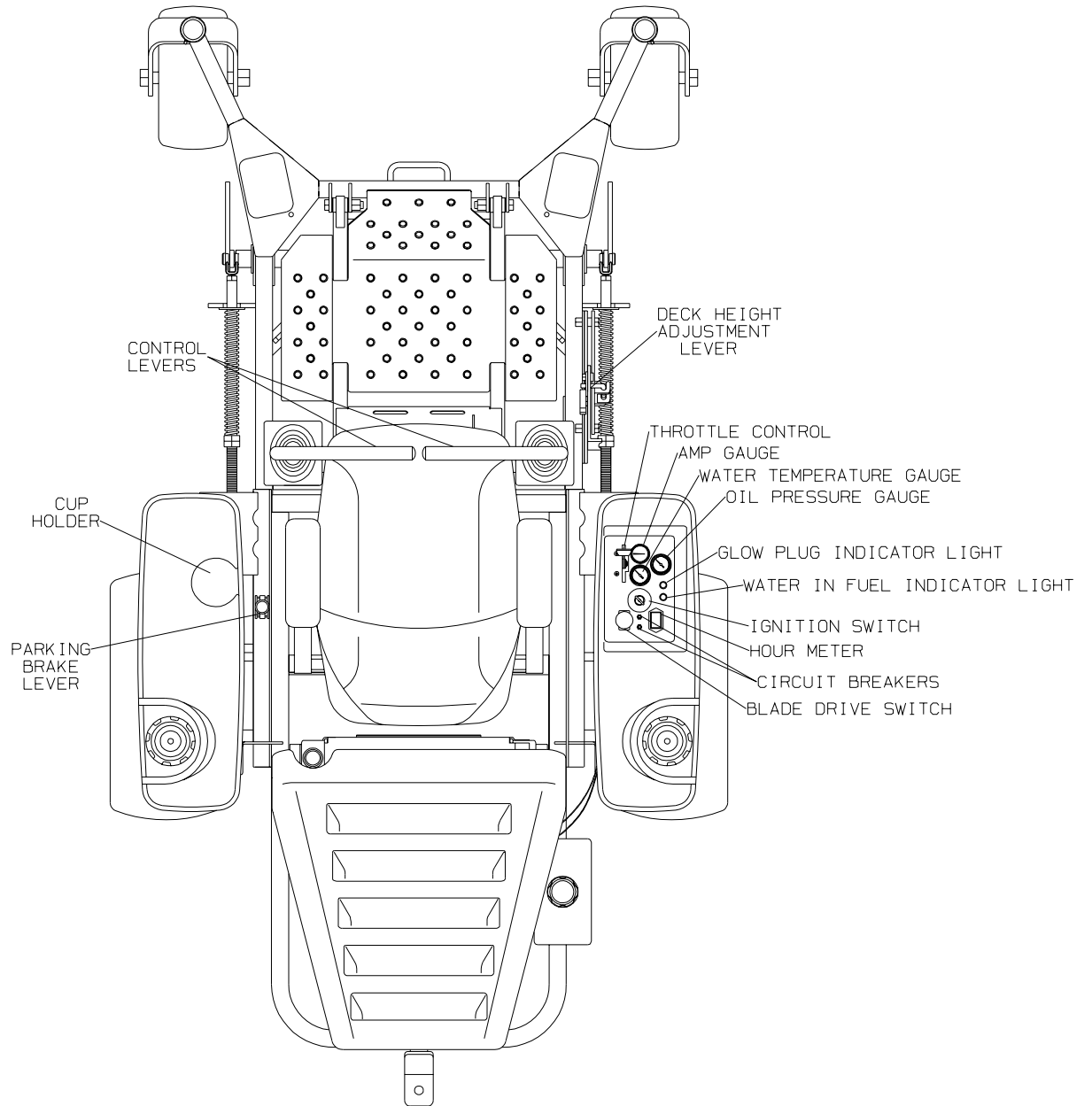

OPERATION INSTRUCTIONS

The safe and successful operation of the Model ZTR 8000 Series Diesel version will depend upon the operator having the correct knowledge of all controls used on the mower and making good judgements about the terrain to be mowed.

NEVER allow anyone to operate the mower without complete knowledge of all controls and their functions.

During initial operation, "learning to drive", set throttle at slow speed.

BEFORE OPERATING MOWER:

1. Read and observe all safety instructions on your mower and in the manual.
2. Read engine manufacturer's operating and maintenance instructions.
3. Check engine oil.
4. Check fuel cap to be sure it is in place.
5. Be sure parking brake is on.
6. Mower blade drive is off.
7. Know how to stop engine. (Turn key to off position)

OPERATION INSTRUCTIONS



TESTING OF SAFETY INTERLOCK SYSTEMS:

Do not operate mower if safety switches are not operating properly.

Your Zero Turning Radius Mower is equipped with control interlocks for your safety.

1. The engine will not start if the mower blades are engaged.
2. The engine will not start unless the steering control levers are neutral "OUT" position.
3. The engine will stop if the mower blade clutch is engaged and the operator leaves the driver's seat.
4. The engine will stop if the park brake is ON and the steering control levers are moved to the "IN" position.

INTERLOCK SWITCH TEST:

Note: Operator must be seated in normal operating position to perform these tests.

1. With engine off, turn mower blade on and attempt to start engine.
Engine should not start.
2. With engine off, move control levers in and attempt to start engine.
Engine should not start.
3. In a SAFE AREA away from bystanders, start the engine, place throttle setting at maximum or full. Engage the blade drive through the electric clutch switch. Raise slightly off of seat. *Engine should stop.*
4. With engine running, set parking brake and move levers inboard.
Engine should stop.

If any safety check fails, do not operate the mower until the system has been checked and repaired by an authorized Dixon ZTR dealer.

OPERATION INSTRUCTIONS

STARTING INSTRUCTIONS:

1. Operator must be seated in normal operating position.
2. Set parking brake.
3. Move control levers to outboard position.
4. Assure blade clutch is off.
5. Push throttle control lever to slow setting.
6. Insert ignition key and turn to run position. Glow plug light should light.
7. When glow plug light goes off turn ignition key to "start" position. When engine starts, release ignition key. Key will return to "run" position.
NOTE: Turn key counter-clockwise one more position for run/lights.
8. Let engine warm up a few minutes then move throttle control lever to the *wide open or maximum* setting for actual operation of the mower deck. Engine must be operated at *wide open or maximum* setting to insure adequate lubrication, cooling and cut quality of the mower deck.



CAUTION

DO NOT operate the engine in an enclosed area due to the harmful exhaust gas produced.

STOPPING INSTRUCTIONS:

1. Turn mower blades off.
2. Move control levers to outboard position.
3. Set parking brake.
4. Move throttle control to slow. Allow engine to run a short time to cool down then turn ignition key to "OFF" and remove key.

OPERATION INSTRUCTIONS

MOWING INSTRUCTIONS:



CAUTION Be sure that deflector is properly installed on the discharge chute.

1. Start engine and set throttle at full speed.
2. Set desired cut height.
3. Release park brake.
4. Move control levers in and operate per the control instructions on Page 12.



CAUTION Check the area around the mower to assure there is no one near.

5. Set RPM at approximately 1/2 speed and engage mower blades.

GRASS HEIGHT AND CUTTING SUGGESTIONS:

Do Not Attempt To Cut Grass When It Is Wet.

If the grass is tall, place the mower deck cut height lever in the top or second notch. "Initially" overlap cutting swaths instead of a full swath with each pass. Some applications may require a second cutting.

Keep The Underside Of The Mower Deck Clean.

Maintain Sharp Blade(s) Throughout The Cutting Season.

As a rule of thumb, never cut off more than 1/3rd of the total grass blade length.

Correct mowing height can reduce weeds and disease by 50% to 80%.

The following grass cut heights are based on adequate moisture conditions and normal thatch buildup in a healthy lawn. Some locations and applications may require slightly different cut heights. If in doubt, consult your local lawn professional for assistance.

Grass Types:	Best Cut Heights:
Zoysia	2" - 2 1/2"
Blue Grass	1 1/2" - 3"
Fescue Blends	1 1/2" - 3"
St. Augustine (Mid South)	1 1/2" - 2"
St. Augustine (Deep South)	3" - 4"
Tifton Bermuda	1 1/2"
Centipede	1 1/2" - 2"
Common Bermuda	1 1/2" - 2"
Bahia/Argentina/Pensacola	2"

OPERATION INSTRUCTIONS

TO LIFT SEAT:

To lift the seat, move the control levers to the neutral out position. Unhook the seat damper by rotating the clip of the retaining pin off of the clevis end and remove the retaining pin. Remove the clevis end of the seat damper from the seat hold down bracket and replace the pin and rotating pin clip to lock them in place. Release the seat latch and rotate the counterbalanced seat support frame upward and forward.

To return the seat to the operating position, push the counterbalance seat frame support rearward and down until it rests firmly on the tractor frame. Reconnect the seat damper by reversing the order of removal as stated above.

SPRINGS:

Three seat springs are provided. The center spring may be removed for a softer ride.

TO FREE WHEEL MACHINE (UNLOCK TRANSMISSION):

Always turn off engine before engaging or disengaging the hydro release (free wheel) valves. Never attempt to move the valves with the engine running.

The hydro release valves are located beneath the seat on the right side of the hydro pump on each side of the machine. To unlock the transmission, lift the seat (see instructions above), rotate the transmission hex valve located on the top of each transmission approximately one turn counter-clockwise.

To re-engage the transmission, rotate each transmission hex valve clockwise to the end of its travel. Return the seat to the operating position.

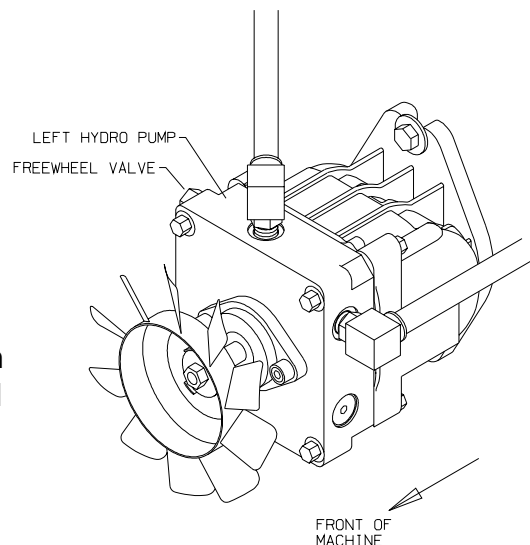

NOTE: Before pushing or towing the tractor, the transmission must be unlocked and the parking brake released. The tractor should never be pulled more than two miles per hour or for any appreciable distance.

CARE AND MAINTENANCE



CAUTION

Before performing any maintenance, turn off engine, allow to cool & remove key. Use extreme care when working on machinery. Do not wear watch or jewelry. Do not wear loose fitting clothes, and observe all common safety practices with tools.

MAINTENANCE SCHEDULE

Check drive and fan belts	every 50 hours
Check deck serpentine belt	after 20 hours break-in (adjust bumper to approximately 1/2" thick)
Check deck drive belt tension adjustment	after 5 hours break-in (adjust spring tension to 7-1/4 to 7-3/4 inside to inside spring hook dimension. (Check belt tension periodically. Make adjustments as necessary.)
Check crankcase oil level	before each use
Clean grass from hydrostat fans, radiator & radiator screen.	before each use
Check air intake screen	after each use
Clean grass under deck.	after each use
Check tire pressure	every 10 hours
Sharpen mower blades	every 10 hours
Clean air filter element	every 25 hours
Check hydrostatic transmission fluid	every 25 hours
Grease all zerks	every 50 hours
Service air filter element.	every 100 hours
Change engine crankcase oil	(5 hours break-in) every 100 hours
Change engine oil filter	every 200 hours
Change hydrostat oil & oil filter.	(100 hours break-in) every 500 hours
Replace air filter element	annually or every 500 hours
Check spark plugs	annually or every 500 hours
Service battery	annually or every 500 hours
Check coolant level in reservoir.	before each use
Change coolant.	annually
Clean grass & debris from muffler & manifold area	before each use

CARE AND MAINTENANCE

ENGINE:

For complete maintenance and operating information of the engine, please refer to the maintenance instructions furnished by the engine manufacturer and included in your Zero Turn Radius Mower information packet.

Note: *Air intake screen must be kept clean. If plugged, engine may be seriously damaged by overheating.*

Note: *Clean radiator chaff screen when it becomes covered during operation.*

BATTERY:



CAUTION Battery electrolyte is a poisonous and corrosive sulfuric acid solution. Avoid spilling on skin, eyes and clothing.

Keep fluid level above the plates in each cell, using distilled water.

OFF SEASON BATTERY STORAGE:

DO NOT remove battery from mower.

Clean top of battery and terminals with baking soda and water.

Identify each cable so cables can be reconnected to correct terminals.

Disconnect cables from terminals. ALWAYS disconnect ground cable first and reconnect last.

Charge battery.

TIRES:

Correct tire pressure is essential for efficient operation of the mower. Check tire pressure periodically. Inflate tires to the pressure listed below.

Front tires - 16-20 lbs.

Rear tires - 8-14 lbs.

Lug nuts or lug bolts should be checked regularly for tightness.

CARE AND MAINTENANCE



CAUTION

Stop engine and remove ignition key for safety. Wear heavy, thick gloves when holding onto cutter blade, avoid the sharp edge of the blade.

MOWER BLADES:

Check sharpness of mower blades after every 10 hours of operation. To sharpen blades, proceed as follows.

- A. Remove bolt and flat washer mounting blade on shaft. Remove blade.
- B. Blades should be discarded when worn excessively.
- C. Sharpen blade with a hand file, electric grinder or blade sharpener. Wear gloves and eye protection when sharpening. Grind blade at original 25 degree bevel.
- D. Check balance of blade by positioning the blade on a nail or blade balance pedestal. Grind the blade on the end that is heavier until both sides balance.
- E. Install blade, flat washer and bolt. Make sure to tighten bolt to 60 ft. lbs.

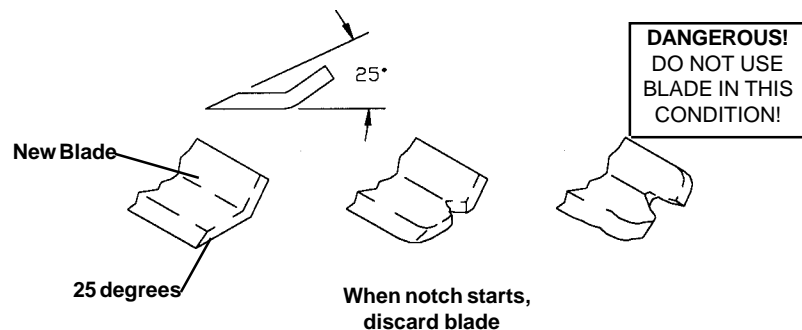

BELTS:

Check belts every 50 hours. Replace any belts found to be in poor condition.

CARE AND MAINTENANCE

LUBRICATION:

- A. Engine: Follow engine manufacturer's recommendation.
- B. Deck spindles: Lubricate with 3 "shots" only, every 100 hours.
- C. Mower chassis: Lubricate with 3 "shots" only, every 50 hours(see zerk locations below).

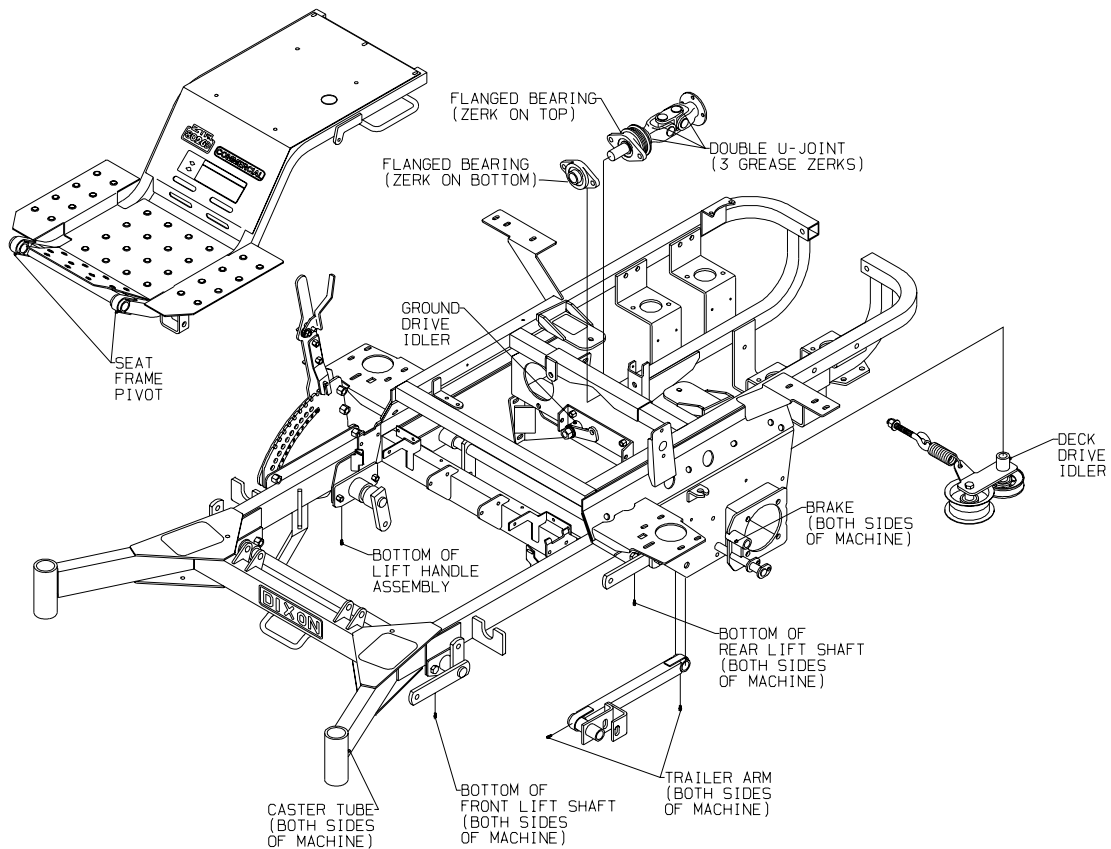

CARE AND MAINTENANCE

CHECKING & REPLENISHING OIL IN HYDROSTATIC TRANSMISSION

Dirt or water in oil can ruin the hydrostatic transmissions.

Check the oil level in hydrostatic transmission oil reservoir after every 25 hours of usage. Clean the oil reservoir cap and the area around it prior to removal. Check the oil level. Oil should be approximately 1-3/8" below top of oil tank. Replenish as needed with SAE 20W-50 motor oil. DO NOT OVERFILL. When checking the oil level, be very careful to keep the reservoir clean.

Change the oil in the reservoir and hydrostat transmission oil filter after the first 100 hours of use. Then every 500 hours after that. Remove the filter and be sure all oil has drained from the reservoir. Replace with new filter and SAE 20W-50 motor oil.

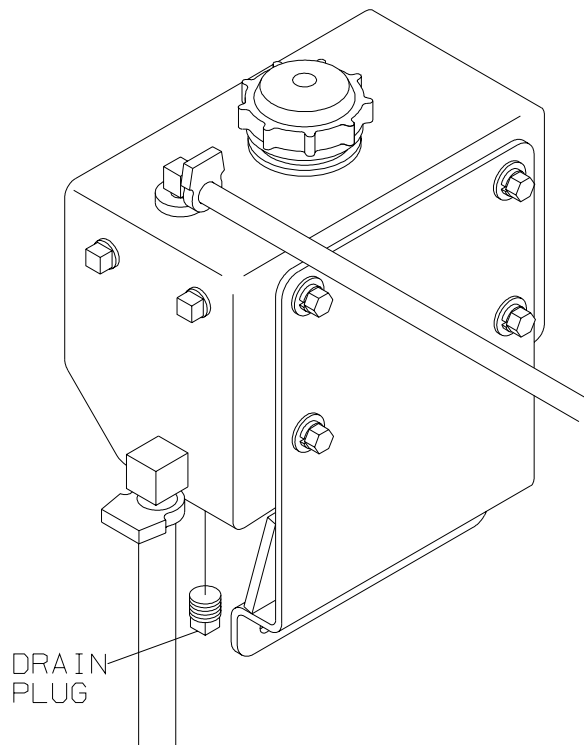

Please dispose of used oil at proper collection centers - protect your environment

CARE AND MAINTENANCE

PARKING BRAKE ADJUSTMENT

1. Loosen the locking screw on the top knob of the brake engaging handle.
2. Rotate it clockwise to increase and counter-clockwise to decrease brake holding power. As the brake holding power is increased the force required on the handle to engage the brake increases.
3. Set the brake for the holding power required for the intended use and the desired force required to activate it.
4. Retighten the knob locking screw.

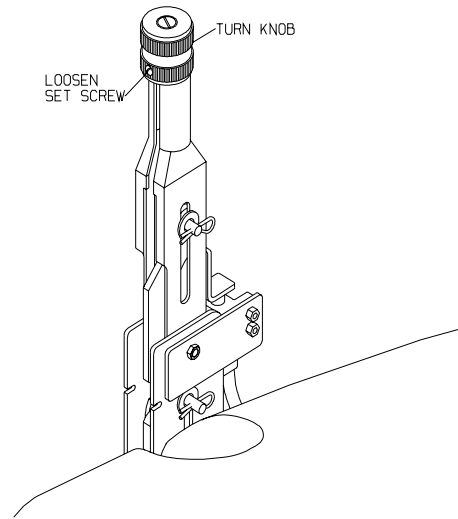

HEADLIGHT ADJUSTMENT

1. Loosen the 1/2" retaining nut underneath the headlight and slide the headlight forward out of the fuel tank.
2. Loosen the 1/2" nut on the "U" shaped holding bracket and swivel the headlight vertically to adjust the height of the beam. Tighten the bracket nut.
3. Replace headlight in fuel tank.
4. Swivel the headlight horizontally to illuminate the desired area and tighten the headlight retaining nut.

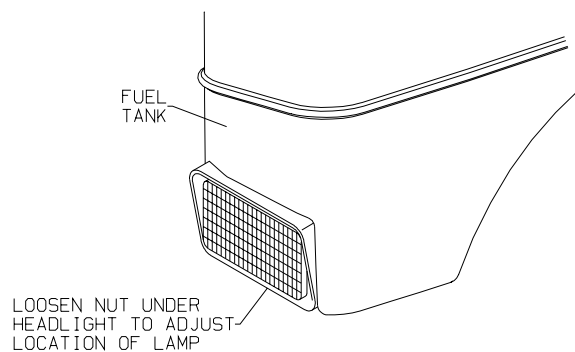

CARE AND MAINTENANCE

HYDROSTATIC PUMPS:

Before each use, check to be sure that the cooling fins of the hydrostatic pumps are clean. Excessive accumulation of oil, dirt, or trash may cause the pumps to overheat. **NEVER WASH ACROSS TOP OF RESERVOIR WITH WATER OR STEAM.** Fill reservoir as required per the maintenance schedule listed in this book.

HYDROSTAT DRIVE BELT REPLACEMENT PROCEDURE:

To remove hydrostat pump drive belt:

(The hydrostat pump drive is equipped with a spring loaded belt take-up).

1. Raise seat.
2. Drain radiator.
3. Remove radiator mounting hardware and hoses.
4. Remove radiator.
5. Remove double u-joint flange bolts and remove double u-joint.
6. Rotate the spring loaded take-up idler towards the left hand hydro pump to provide belt slack for removal.
7. Remove belt.

To install hydrostat pump drive belt:

1. Rotate the spring loaded take-up idler towards the left hand hydro pump.
2. Install belt per diagram.
3. Install double u-joint and tighten flange bolts. (tighten to 14 ft. lbs).
4. Install radiator and mounting hardware.
5. Attach radiator hoses and refill cooling system.

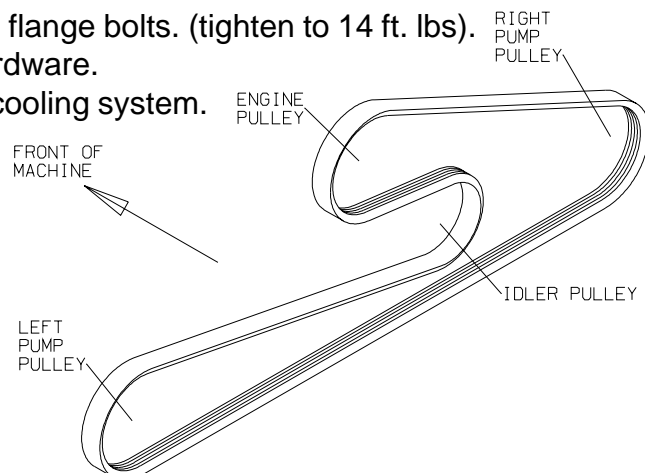

CARE AND MAINTENANCE

STEERING CONTROL ADJUSTMENTS

A. To Adjust Neutral:

1. Lift seat. (See instructions on Page 20)
2. Block up the unit so that the drive wheels are off the ground.
3. Loosen ball joint jam nuts on control rod.
Note: The front jam nuts are left hand threads.
4. With steering control arms in the out/neutral position, start the engine and run at fast idle.
5. Adjust the Neutral Position by turning the control rod until the wheels do not rotate.
6. Retighten the jam nuts on the control rod and check to see that the drive wheels are not turning.
7. Repeat steps 3-6 for the other side.
8. Shut off engine before removing the blocks.
9. Return the seat to the operating position.

B. To Adjust Neutral Springs:

1. Loosen set screws of front and rear spring stop collars located on the control rods. (Requires a 1/8" Allen wrench).
2. Move control handle full forward.
3. Move front spring stop collar rearward until it compresses spring approximately 1/16" and tighten collar set screw.
4. Move control handle full rearward.
5. Move rear spring stop collar forward until it compresses spring approximately 1/16" and tighten collar set screw.
6. Repeat steps 1-5 for opposite side.

CARE AND MAINTENANCE

STEERING CONTROL ADJUSTMENTS (continued):

C. To Adjust Steering Control Levers:

1. Loosen the front and rear bolts retaining the bellows hold down plate and slide the bellows and plate up the steering lever to expose the steering control mechanism.
2. Move the levers inboard to the operating position.
3. Loosen the set screw of the clamp collars which lock the upper arms to the lower arms.
4. Raise or lower the arms for desired height. There is approximately 3" of height adjustment available. Upper shaft should have a minimum of 1-1/2" engagement in lower shaft.
5. Rotate arms until they have the desired orientation front to back.
6. Tighten the clamp collar set screws.

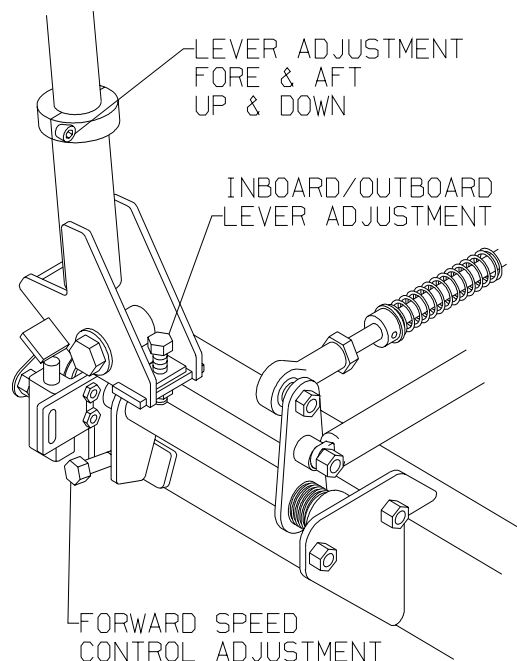

D. To Adjust "In" Position of the Steering Controls

1. Move the levers inboard to the operating position. Adjust the steering lever stops until the steering levers have the desired clearance.

E. To Adjust for Straight Forward Tracking

1. Drive tractor with both control levers in the full forward position.
2. Stop the machine and shut off the engine.
3. Adjust the forward stop of the control levers on the side which appears to be faster to limit the forward travel of the control levers until the mower tracks in a straight line.
Note: Variations in the turf and tire pressure can cause variations in speed and tracking.

- F. When all alignment adjustments are satisfactory, slide the hold down plate and bellows down the control levers and secure with screws.

CARE AND MAINTENANCE

LEVELING THE DECK

1. Set the tire pressure on all four tires.
2. Front casters must be rotated in the direction of forward travel.
3. Move the tractor to a hard level surface.
4. Put the mower deck in the number 3 deck height position.
5. Loosen the jam nuts on the front and rear deck hangers.
6. Rotate the 2 outer spindles so the blades point outboard.
7. Adjust front hangers to level deck side to side.
8. Rotate all 3 spindles until the blades are fore and aft.
9. Adjust rear hangers until deck is level to 3/8" higher in the rear.
10. Retighten the jam nuts on the front and rear deck hangers.

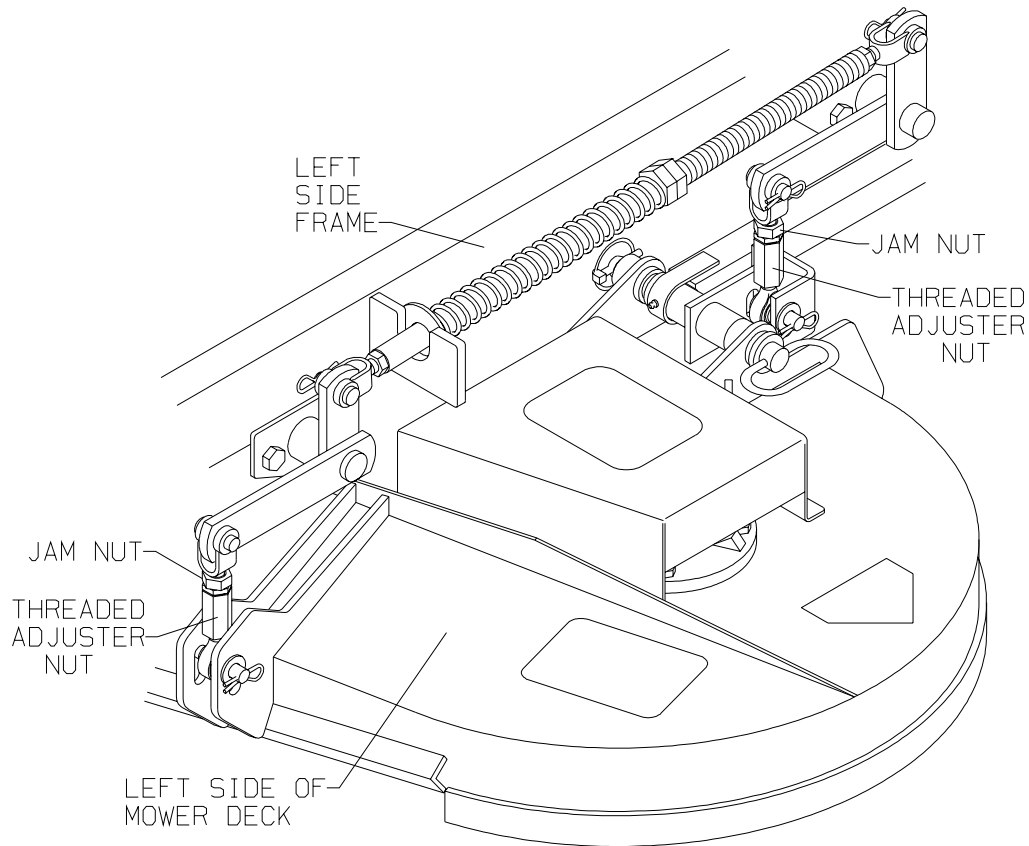

STANDARD SERVICE PARTS LIST

MODEL ZTR 8026D:

BLADES:	P/N 12421 (60")
BLADES:	P/N 12339 (72")
ENGINE TO MOWER DECK BELT:	P/N 12503 (60" and 72")
SERPENTINE BELT:	P/N 9758 (60") 12033 (72")
ENGINE TO HYDRO BELT:	P/N 12012
HYDROSTATIC TRANSMISSION FILTER:	P/N 7252

BRIGGS & STRATTON AIR AND OIL FILTER PART NUMBERS:

Refer to engine manufacturers manual for recommendations regarding frequency of service required for engine oil changes and air filter maintenance.

Protect your engine investment, use only original equipment filters.

Model ZTR 8026D:	25HP	Air Filter & Pre-Cleaner Kit	78003
		Engine Oil Filter	78006

IMPORTANT:

Some applications, extreme dirt conditions, or the use of a grass catcher may require that the engine used on the Model ZTR 8026D be fitted with an *OPTIONAL Briggs & Stratton fresh air filter system*.

Listed below are the B&S kit numbers required to adapt these components to the engine. Consult your dealer or a B&S engine service center for additional information.

Model ZTR 8026D:	25HP	Check with B&S Dealer for availability
------------------	------	--

TROUBLESHOOTING

1. ENGINE WON'T TURN OVER

Mower blades engaged-----disengage blades
Drive not in neutral-----move steering control levers to neutral "OUT" position
Blown fuse-----replace fuse
Dead battery-----charge or replace
Solenoid -----consult dealer
Ignition switch-----consult dealer
Starter -----consult dealer
Parking brake not on-----engage parking brake

2. ENGINE WILL TURN OVER BUT WON'T START

No fuel -----refuel and/or clean or replace fuel filters

3. HARD TO START ENGINE

Fuel line clogged -----clean fuel line and check fuel filter
Faulty fuel pump -----consult dealer

4. ENGINE STARTS BUT CUTS OUT

Water in fuel----- drain old fuel-replace with new fuel
Clogged fuel line -----check fuel filter
Fuel tank vent plugged -----clean fuel line
Faulty fuel pump -----check vent
Engine dies when control levers moved "IN"-----parking brake set-release brake

**see engine manual for engine adjustments*

TROUBLESHOOTING

5. ENGINE OVERHEATED

Air intake screen or fins clogged -----clean intake screen and fins
Oil level too low or too high -----adjust oil level
Running engine too slow -----run engine faster

6. ENGINE RUNS BUT MOWER WON'T MOVE FORWARD

Drive belt broken or slipping----- replace drive belt
Shift linkage cable disconnected -----reconnect
Transmission shift arm disconnected -----reconnect
Transmission oil low -----add oil
Transmission locks in free wheel position-----put in lock position (see pg. 20)
Hydrostat oil filter plugged----- replace filter
Bad transmission -----consult dealer
Gear mating transmission/gearbox disconnected -----consult dealer

7. MOWER LOSES POWER OR TRANSMISSION OVERHEATS

Hydrostat transmission oil too low or too high ---- add oil or drain oil as needed
Transmission damage-----consult dealer
Transmission blowing oil out cap-----overfilled or water contaminated

8. ENGINE STALLS WHEN BLADES ARE ENGAGED

Operator not on seat-----sit on seat
Faulty interlock system-----consult dealer
Bad blade spindle bearing -----consult dealer
Deck drive belt not properly routed-----reroute
Blades blocked by foreign material-----clean under deck

**see engine manual for engine adjustments*

NOTES

OWNER INFORMATION



DIXON INDUSTRIES, INC.
A BLOUNT International Inc. Co.
PO BOX 1569
COFFEYVILLE KS 67337 0945
316 251 2000
FAX 316 251 4117



DATE PURCHASED _____

MOWER MODEL NUMBER _____

MOWER SERIAL NUMBER _____

PURCHASED FROM _____

Name

Address

DATE OIL CHANGED:

DATE ENGINE TUNED:



⚠ WARNING: *The engine exhaust from this product contains chemicals known to the State of California to cause cancer, birth defects or other reproductive harm.*

Dixon® and ZTR® are registered trademarks of Dixon Industries, Inc.

DIXON INDUSTRIES, INC.
A BLOUNT International Inc. Co.
PO BOX 1569
COFFEYVILLE KS 67337 0945
316 251 2000

8000 Series (Diesel)
8026D
Part No. 13282-0201