



**DIXON®**

**OPERATOR'S MANUAL**

**ZTR®**

**ZEETER™**

**422 & 424**

## **IMPORTANT**

The Dixon ZTR mower is both easy and fun to operate. However, any power mower must be operated properly to be safe. It is not a toy or a recreational vehicle. Before you start to use the mower, read the operator's manual carefully, and become completely familiar with the controls. Your Dixon dealer will gladly provide a check-out ride, and answer any questions.

## **READ CAREFULLY**

You have purchased a top quality lawn mower that has been carefully inspected and adjusted at the factory. This lawn mower is warranted for 1 year from date of delivery against all defects in materials and workmanship. Lawn mowers used for commercial service are warranted for 30 days from date of delivery. **SEE YOUR DEALER FOR WARRANTY SERVICE OR PARTS.**

## **ONE-YEAR LIMITED WARRANTY**

This lawn mower is warranted for one (1) year from date of delivery against all defects in materials and workmanship. Lawn mowers used for commercial service are warranted for 30 days from date of delivery. (Lawn mowers other than those used only at residence of owner are considered as commercial service.)

Each new mower is warranted against manufacturing defects in material and workmanship under normal use and service. Our obligation, under this warranty, shall be limited to the replacement to the original retail purchaser of any part or parts, which, within the warranty period, shall be shown to be defective due to faulty workmanship or materials at the factory. All parts claimed defective must be returned to the factory for inspection, repair, or replacement with transportation charges prepaid.

This warranty does not apply to damage in transit or damage caused by misuse, negligence or accident, to alterations or repairs done outside the factory or authorized service stations, nor does it obligate us to assume any transportation charges in connection with the replacement of parts claimed to be defective.

Our warranty does not apply to the blades, adapters, chains or belts on our mowers due to the very nature of the function they perform and to the elements they are exposed to.

The warranty specifically excludes engines, tires, and batteries which are warranted separately by their respective manufacturers. All claims for defective engines or engine parts must be made in accordance with the engine manufacturer's warranty.

We reserve the right to make changes in design and changes or improvements on our product without imposing any obligation upon ourselves to install the same on products heretofore manufactured.

This warranty is null and void if any parts other than original manufacturer's parts are used. There is no other express warranty.

**IMPLIED WARRANTIES**, including those of merchantability and fitness for a particular purpose, are limited to one (1) year from purchase-and, to the extent permitted by law, any and all implied warranties are excluded.

## SERIAL NUMBERS

The lawn mower has three serial numbers:

Mower Number — Located on frame at right rear transaxle mount. Transaxle Number — Located on transaxle.

Engine Number — Located on engine. When referring to serial number on Warranty Registration, etc., use Mower Serial Number located on frame.

## SAFETY INSTRUCTIONS

### BEFORE MOWING

1. Read these safety instructions and engine manufacturer's operating and maintenance instructions that are furnished with the mower.
2. Discuss proper maintenance with your Dixon dealer, to save money and prevent injury. Consult your dealer before removing any parts.
3. Don't allow anyone to operate your Dixon mower without proper instruction. Young children should never be allowed to operate any power mower, riding or walking.
4. Before mowing, pick up all debris — particularly stones and sharp objects.
5. Before starting the engine, make sure the gas cap is in place.

### DURING MOWER OPERATION

1. The revolutionary Dixon mower attracts many admiring neighbors. But when mowing, all persons — especially children — and pets should be cleared from the mowing area.
2. Wear appropriate, safe clothing when mowing — close-fitting jeans or slacks and heavy leather or safety shoes with rough soles. Never use any kind of mower with bare feet or open sandals, not even an old push-type model!
3. When grass is wet or slippery, do not use any riding mower.
4. Always mow at the slowest speed that will cut satisfactorily.
5. Keep hands and feet away from the blade at all times.
6. Although the Dixon mower is equipped with a missile

- deflector which directs downwards all blade-propelled objects, keep persons clear of the discharge chute. Do not operate mower unless deflector is in place.
7. Use extreme caution when mowing hills or slopes with *any* mower.
  8. Always disengage blades before taking the mower across walks or objects that project above the surface.
  9. When the mower is not in use, turn the engine off; never leave the engine running unattended. Your Dixon mower is equipped with a weight-sensitive switch that kills the engine when operator leaves the seat while blades are engaged. Test this important safety feature before each time mower is used. This may be done by starting engine, engaging blades and then rising slightly from seat. If engine does not stop, see your dealer for necessary repair.
  10. Before adjusting your mower or adding fuel, turn the engine off. Let it cool, and disconnect the spark plug so the engine cannot start by accident. Be sure all moving parts are stopped.
  11. Never run the engine indoors; the fumes are dangerous.
  12. Before backing your Dixon mower, stop, turn around, and look.
  13. Gasoline fumes are explosive; use only approved gasoline containers to store small amount of fuel. No special oil/gas mixtures are needed for your Dixon mower.
  14. If the mower should start vibrating, stop the engine immediately and check for damage or loose parts. Vibration is usually the warning of trouble.
  15. Never lift lawn mower by the body; lift only by the frame.
  16. Never carry passengers.

**ALWAYS SET PARKING BRAKE AND DISENGAGE BLADE OPERATION BEFORE DISMOUNTING.**

## IMPORTANT OPERATING INSTRUCTIONS

Dixon ZTR mowers offer a new concept in mowing, providing unique maneuverability and ease. The following procedures will allow one to become familiar with the unique method of control very easily.

1. SET PARKING BRAKE — Be sure that drive levers are free and in the neutral position. (When drive levers are released, they should return to neutral position.)
2. "Blade Operation" lever is to be set in the "Disengage" position.
3. Move throttle control to "Choke" position.
4. To start models with electric starting, simply insert ignition key and turn to the far right position. When the engine starts, release the ignition key and it will remain in the "RUN" position. To stop the engine simply turn the key to the "OFF" position.

NOTE: Some electric start models are also equipped with manual start provision. To start engine manually turn switch to "RUN" and pull the starter rope.

5. Set engine to desired speed by adjusting throttle control. (Suggest set at slow speed during initial operation.)
6. NOTE SAFETY FEATURE: Safety switches stop engine when operator leaves seat while blades are engaged, and engine cannot be started when blades are engaged. OPERATOR SHOULD TAKE PRECAUTIONS AND NOT RELY ON SAFETY SWITCHES.
7. This unit is equipped with a unique transaxle that requires only two drive levers to control braking, turning, direction and acceleration. TO GO FORWARD

From neutral position gently push both drive levers forward; to increase speed move levers further forward.

### TO GO BACKWARD

From neutral position gently pull both drive levers rearward.

### TURNING

Turning is controlled by moving one drive lever slightly forward or rearward of the other. To turn left, move left lever rearward of right lever. To turn "square corners" move lever of desired direction to neutral. To turn on mower's own axis (Zero Radius) reduce speed and move one lever to reverse position and the other to forward position.

### BRAKING

To brake mower, move both levers in direction opposite of travel, release levers to neutral, set parking brake. When stopping on incline, it may be necessary to hold slight pressure on levers in direction opposite of slope, until parking brake is set.

### ALWAYS SET PARKING BRAKE BEFORE DISMOUNTING.

### INITIAL OPERATION

It is recommended that first operation of mower be done at a slow throttle setting with mower blades disengaged until operator is thoroughly familiar with the unit.

**You may have a tendency to "over control" mower at first. Slight movement — fingertip control — is all that's necessary for easy operation.**

8. Mower Blade operation:
  - Cutting height is set by positioning the adjustment lever. Push button knob on top of lever, set desired cutting height, lock in to position by releasing button knob.
  - To start mower blades, move lever on floor to "engage" position. To stop mower blades, move lever to "disengage" position.

**ALWAYS DISENGAGE BLADE OPERATION BEFORE DISMOUNTING.**

9. Parking Brake:

Parking brake is on right hand side of floor area and is engaged by pushing full forward with foot. To disengage, pull lever back toward operator by hand. In emergency situations, brake may be used in conjunction with the natural braking of the transaxle by applying pressure with foot. Always set parking brake before dismounting. Be sure that parking brake is disengaged before moving.

**MAINTENANCE**

**BEFORE PERFORMING ANY MAINTENANCE, SHUT OFF ENGINE, ALLOW TO COOL AND DISCONNECT SPARK PLUG.**

**ENGINE**

For complete engine operating and maintenance information, refer to engine operating and maintenance instructions furnished by the engine manufacturer and supplied with each mower.

**BATTERY**

Procedure for initial activation of battery:

1. Fill with electrolyte solution to lower ring of battery.
2. Let stand for 30 minutes.
3. Charge at 4 amps for 3 hours or 1 amp for 12 hours.
4. After initial filling, fluid level may be maintained with distilled water.

Procedure for off-season storage:

1. Charge battery.
2. Disconnect cables from battery terminals. Identify cables so that they may be easily reconnected to -the correct

terminal. (See also wiring diagram shown on Body Assembly illustration.)

3. Clean top of battery and terminals.
4. Do not remove battery from mower.
5. To reactivate, reconnect cables to correct terminals and charge battery if needed.

**BELT ADJUSTMENT**

The best tension for a V-belt drive is the lowest tension at which the belts will not slip under normal load condition. Check the tension on a new belt frequently during first hours of operation and every 10-15 hours or monthly thereafter. Too much tension shortens belt and bearing life. Too little tension causes slippage and loss of power. Be sure that belts and pulleys are kept free of foreign material. If belt slippage occurs, tighten it just enough to prevent slippage.

**TRANSAXLE DRIVE BELT**

To adjust tension, loosen 4 bolts which hold engine to mount and belt keeper in place. Loosen tension bolt located at rear of machine. Adjust tension bolt until desired tension is achieved, tighten 4 bolts holding engine and tighten tension bolt lock nut.

**MOWER DRIVE BELT**

Belt tension for mower drive belt is adjusted by loosening nut on mower deck turnbuckle assembly and turning turnbuckle to achieve desired tension. Retighten nut. Tension should be checked with belt in engaged position.

**REPLACE BELTS WHEN ADJUSTMENT CAN NO LONGER BE MADE SATISFACTORILY OR IF BELTS BECOME WORN.**

## BODY REMOVAL

### A. ZTR-424 Body Removal

1. Disconnect throttle cable from engine.
2. Disconnect key switch wire loom from frame wire loom at front of body.
3. Disconnect seat switch wire loom from frame wire loom. This connection is located approximately level with the back of the seat on left hand side of frame under the body.
4. Remove four control lever bolts and remove upper control levers.
5. Remove engaging handle by removing bolt and nut under handle. - 6. Disconnect brake pedal from pedal arm by removing the two bolts. 7. Remove two acorn nuts on front floor and the two sheet metal screws in transaxle body mount. Body will lift clear. To replace body reverse the above procedure.

### B. ZTR-422 Body Removal

1. Disconnect throttle cable from engine.
2. Disconnect two wire loom plugs, one going to engine wires and one going to switch. Plugs are located between back of transaxle mount and battery.

OMIT STEP (3) AND FOLLOW ZTR-424 BODY REMOVAL INSTRUCTIONS FROM STEP (4) ON. REMEMBER TO REINSTALL SWITCH GROUND WIRE ON LEFT REAR TRANSAXLE BODY MOUNT SCREW.

## CHAIN DRIVES

### ADJUSTMENT

To adjust the drive chains, the body must be removed and shims added behind the transaxle. Loosen 4 bolts which hold the transaxle to the frame. Insert shims as needed for adjustment between transaxle and mount plates. When properly adjusted, the slack span at the mid-point of the chain should have a total possible movement perpendicular to the chain of about 9/16". Tighten the 4 bolts which hold the transaxle to the frame. Replace chain when rollers become loose, chain breaks, or chain fails to operate properly.

### LUBRICATION

1. Chains: Proper lubrication is important for effective roller chain operation. Use high quality lubricating oil (do not use grease or extra heavy oil) and apply drops of oil to the chain joints every 10-15 hours of operation.
2. Front Caster Assembly: Each caster assembly has a grease fitting located on the under side of the bearing. For best results, use any good multi-purpose grease every 10-15 hours of operation.
3. All other Bearings: All other bearings on your mower are sealed and require no lubrication.

### WHEELS AND TIRES

Correct tire pressure is essential to the correct operation of the machine. The correct pressure for the drive tires is 8-10 lbs. The front tires should be inflated to 20-24 lbs. Lug nuts should be checked periodically.

### ELECTRICAL SYSTEMS

Keep all connections clean and tight. Maintain the fluid in the battery at correct level.

### BODY

The body may be washed with a mild detergent and waxed with any automotive type wax.

### TRANSAXLE

For adjustment or repair confer with authorized Dixon dealer service department. Adjustment or repair by other than authorized dealer voids warranty.

### SPARE PARTS

See your dealer for ordering spare parts or warranty service.

## INSTALLING AND REMOVING MOWER DECK FROM FRAME

1. Attach stabilizer arms to mower deck with pins and clips-as shown on drawing.
2. Attach the ½ " dia. engaging rod with a rollpin through the engaging cam.
3. Position the drive belt on pulleys.
4. Place mower deck under unit in approximate operating position with engaging rod through hole in the floor.
5. Connect drive belt to lower engine pulley, being certain that belt is inside of belt guides. Loosen belt keeper by loosening the two rear engine mount bolts; this will allow belt to be placed on motor pulley. Retighten engine mount bolts.
6. Attach lift linkage to mower deck on the inside of the attaching lugs as shown on drawing with pins and clips. (4 places)
7. Attach stabilizer arms to pivot point on the inside of attaching bracket with pins and clips.
8. Place engaging handle on engaging rod and fasten with bolt and locknut.
9. Connect pan wire loom plug to plug on frame wire loom. Mower will not start unless this connection is made.

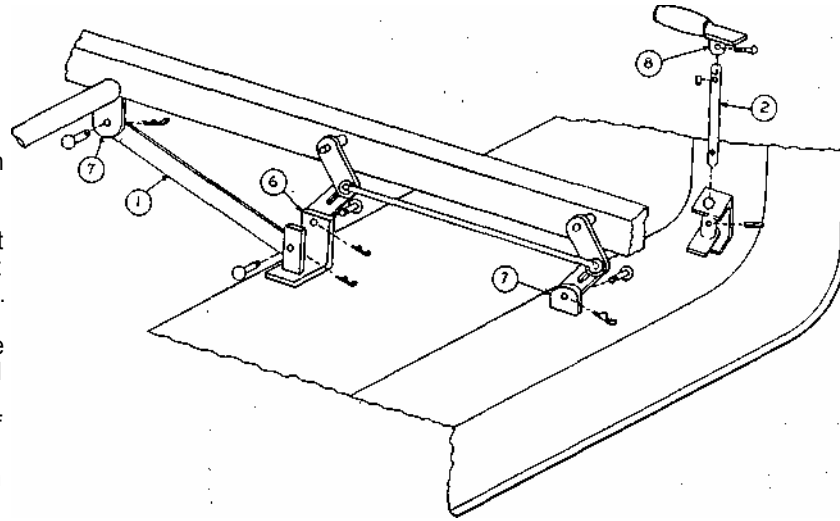

10. After installing pin clips, rotate pins so that open end of clip is down.

# BODY ASSEMBLY

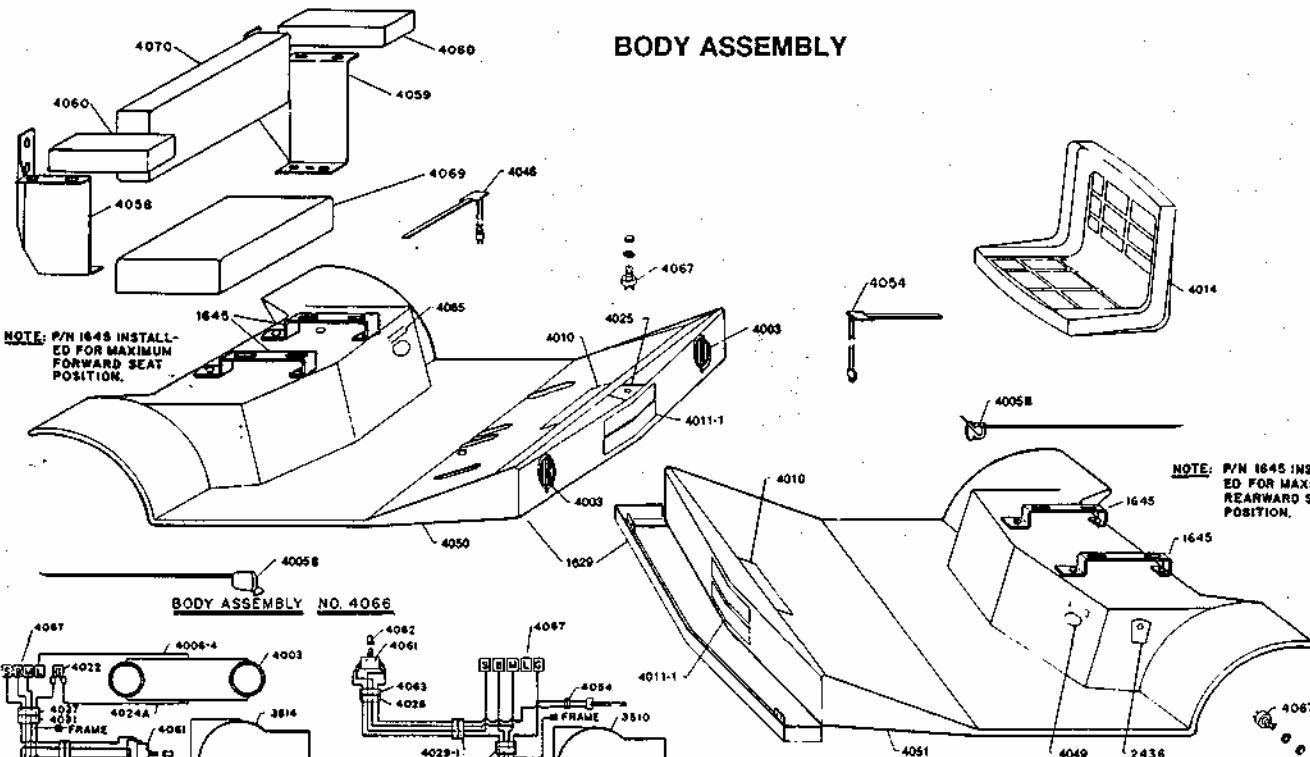

NOTE: P/N 1645 INSTALLED FOR MAXIMUM FORWARD SEAT POSITION.

NOTE: P/N 1645 INSTALLED FOR MAXIMUM REARWARD SEAT POSITION.

**BODY ASSEMBLY NO. 4066**

**BODY ASSEMBLY NO. 4042B**

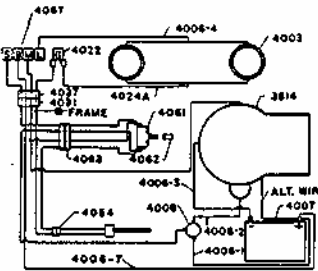

**ZTR-424 WIRING DIAGRAM**

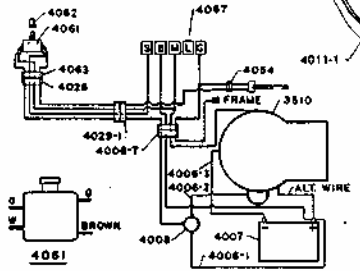

**ZTR-422 WIRING DIAGRAM**

**WIRING COLOR CODE**  
 GREEN - SOLENOID  
 RED - BATTERY POSITIVE  
 BLACK - BATTERY NEGATIVE  
 BROWN - ENGINE (MAGNETO)  
 WHITE - GROUND



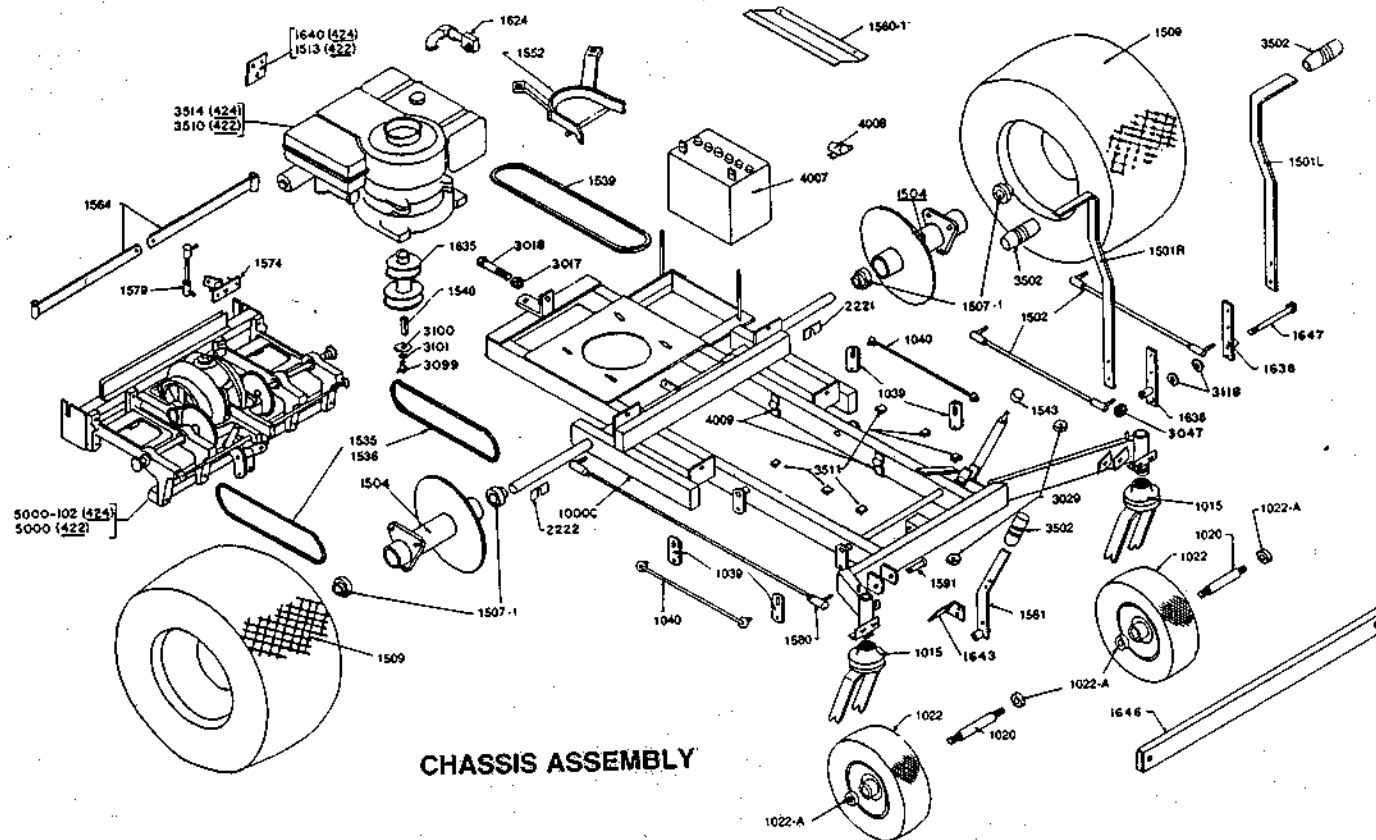

# TRANSAXLE ASSEMBLY 5000-102

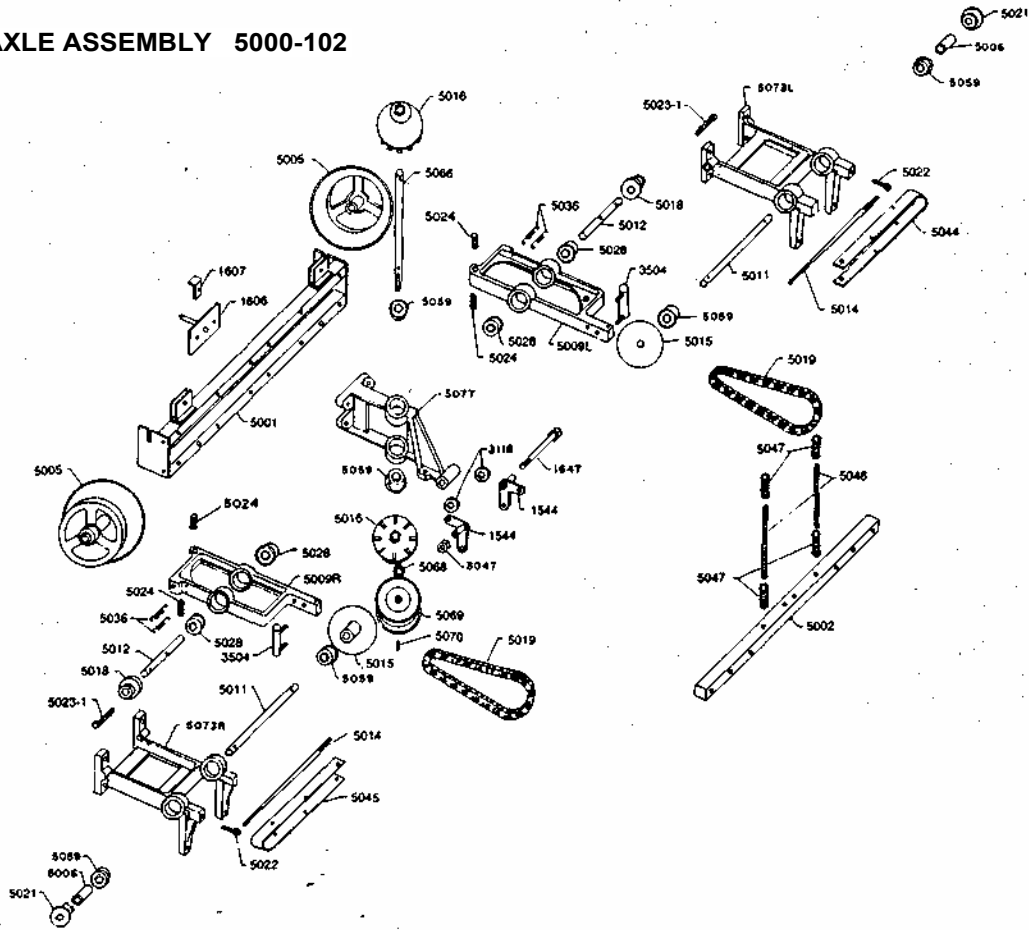





**PARTS LIST FOR 42" MODELS**

Part No.	Name
1000C	Frame Weldment
1015	Caster Weldment
1020	Caster Axle
1022	Caster Wheel & Tire
1022A	Caster Wheel Bearing
1039	Lower Lift Link
1040	Lift Tie Rod Weldment
1501R	Upper Control Lever R
1501L	Upper Control Lever L
1502	Control Rod Assembly
1503	Wheel Hub Assembly
1504	Wheel Hub
1506	Hub Flange
1507-1	Wheel/Hub Bearing
1509	Rear Wheel & Tire
1513	Tension Plate 8 h.p.
1535	Drive Chain
1536	Chain Connecting Link
1539	Transaxle Drive Belt
1540	Engine Shaft Key
1543	Lift Knob
1544	Bellcrank Assembly
1552	Belt Keeper Weldment
1560-1	Battery Splash Guard
1564	Brake Arm Weldment
1574	Brake Pivot Weldment
1579	Short Brake Rod
1580	Long Brake Rod
1581	Brake Pedal Arm Weldment
1591	Brake Pedal Pin
1606	Brake Mount Weldment
1607	Brake Stop
1624	Oil Drain Assembly

Part No.	Name
1629	Bumper Weldment
1635	Double Engine Pulley
1636	Bellcrank Kit
1638	Lower Control Lever Assembly
1640	Tension Plate 11 h.p.
1641	Pan Switch Spacer
1643	Brake Pedal
1645	Seat Bracket, ZTR-422
1646	Weight Brace
1647	Control Pin
2221	Transaxle Shim 16 ga.
2222	Transaxle Shim 22 ga.
2436	Switch Decal, ZTR-422
2813	Seat Switch, ZTR-422
3016	$\frac{3}{8}$ " 24UNF x 1" Lug Bolt
3017	$\frac{1}{2}$ " 13UNC Tension Nut
3018	$\frac{1}{2}$ " 13UNC x 3" HH Tension Bolt
3022	$\frac{1}{4}$ " Int.-Ext. Lockwasher (not shown)
3025	$\frac{1}{4}$ " x 1" Spirol Pin (not shown)
3026	$\frac{1}{4}$ " x 1 $\frac{1}{2}$ " Spirol Pin (not shown)
3029	Front Grommet
3031	$\frac{5}{16}$ " 18UNC Acorn Nut (not shown)
3032	$\frac{1}{2}$ " Helical Lockwasher (not shown)
3038	$\frac{3}{4}$ " 16UNF Hex Jam Locknut (not shown)
3039	$\frac{3}{8}$ " 24UNF Hex Lug Nut (not shown)
3047	$\frac{3}{8}$ " 24UNF Hex Locknut
3054	$\frac{3}{16}$ " x 1" Roll Pin (not shown)
3057	$\frac{3}{8}$ " Std. Flat Washer (not shown)
3059	Spring Wire Clip (not shown)
3070	$\frac{1}{4}$ " x 1 $\frac{1}{4}$ " Spirol Pin (not shown)
3072	Hair Pin Cotter (not shown)
3099	$\frac{7}{16}$ " 20UNF x $\frac{3}{4}$ " HH Bolt
3100	$\frac{7}{16}$ " HD Flat Washer
3101	$\frac{7}{16}$ " Lockwasher

Part No.	Name
3105	HD $\frac{1}{4}$ " x 1 $\frac{1}{4}$ " Spirol Pin (not shown)
3106	HD $\frac{1}{4}$ " x 1" Spirol Pin (not shown)
3107	HD $\frac{1}{4}$ " x 1 $\frac{1}{2}$ " Spirol Pin (not shown)
3118	Disc Spring
3502	Hand Grip
3504	Double Ball Joint
3507	Floor Pad - Long (not shown)
3508	Floor Pad - Short (not shown)
3511	Adhesive Bumper
4003	Headlight Assembly, ZTR-424
4005B	Throttle Cable
4006-1	Battery - Solenoid Cable
4006-2	Solenoid Starter Cable
4006-3	9" Ground Wire
4006-4	Headlight Switch Wire, ZTR-424
4006-7	Rear Wire Loom, ZTR-422
4007	12 Volt Battery
4008	Solenoid
4009	Wire Clip (not shown)
4010	Control Decal, ZTR-424
4011-1	Name Decal, DIXON
4014	Seat - ZTR-422
4014A	Seat Assembly, ZTR-422 (includes 4054)
4022	Ground Terminal ZTR-421/424
4024A	Headlight Ground Wire, ZTR-421/424
4025	Switch Decal, ZTR-424
4028	Frame Wire Loom, ZTR-422
4029-1	Switch Loom, ZTR-422
4030-1	Seat Switch Wire Loom, ZTR-424 (not shown)
4031	Frame Wire Loom, ZTR-424
4037	Switch Loom, ZTR-424
4046	Seat Switch Assembly, ZTR-424
4049	Decal, ZTR-422
4050	Body, ZTR-424

Part No.	Name
4051	Body, ZTR-422
4054	Seat Switch Assembly, ZTR-422
4058	Arm Rest Bracket R, ZTR-424
4059	Arm Rest Bracket L, ZTR-424
4060	Arm Rest
4061	Pan Switch
4062	Switch Boot
4063	Pan Loom
4065	Decal, ZTR-424
4067	Ignition Switch
4067A	Switch Key (for 4067)
4069	Seat Bottom, ZTR-424
4070	Seat Back, ZTR-424
4071	Seat Assembly, ZTR-424 -
4072	Wiring Kit, ZTR-422
4074	Wiring Kit, ZTR-424
5000	Transaxle, ZTR-422
5000-102	Transaxle, ZTR-424
5001	Rear Tube Assembly
5002	Front Tube
5003R	Support R, ZTR-422
5003L	Support L, ZTR-422
5004R	Support Assembly R ZTR-422
5004L	Support Assembly L, ZTR-422
5005	Discup
5006	Support Spacer
5007	Cone Frame, ZTR-422
5009R	Cradle R
5009L	Cradle L
5010R	Cradle Assembly R
5010L	Cradle Assembly L
5011	Support Shaft
5012	Cradle Shaft
5013	Cone Frame Shaft, ZTR-422

Part No.	Name
5014	Torque Rod
5015	24 T Sprocket
5016	Moulded Cone (each)
5018	9 T Sprocket - Narrow
5019	Transaxle Chain
5021	9 T Sprocket - Wide
5022	Thumbscrew
5023-1	Pivot Bolt
5024	Cradle Spring
5025	Cone Frame Assembly, ZTR-422
5028	Transaxle Bearing
5028A	Notched Bearing, ZTR-422
5035	Transaxle V-Pulley, ZTR-422
5036	Pivot Spring
5044	Torque Rod Stiffener L
5045	Torque Rod Stiffener R
5046	Positive Neutral Rod
5047	Positive Neutral Spring
5050	Positive Neutral Kit
5055	Torque Rod Stiffener Kit
5059	Double Bearing, ZTR-424
5061R	HD Support Assembly R, ZTR-424
5061L	HD Support Assembly L, ZTR-424
5065	HD Cone Frame Assembly, ZTR-424
5066	HD Cone Frame Shaft, ZTR-424
5068	HD Pulley Spacer, ZTR-424
5069	HD Transaxle Pulley, ZTR-424
5070	Transaxle Key, ZTR-424
5073R	HD Support R, ZTR-424
5073L	HD Support L, ZTR-424
5077	HD Cone Frame, ZTR-424
6030	Mower Deck Assembly
6040	Mower Deck Weldment
6052	.Stabilizer Arm

Part No.	Name
6058	V-Pulley
6059	Flat Idler Pulley
6060	Serpentine Idler Weldment
6063	$\frac{5}{8}$ " OD x $\frac{3}{8}$ " ID Bronze Bushing
6065	Serpentine Idler Spring
6070	Engaging Idler Weldment
6075	Engaging Idler Spacer
6077-1	Bearing Spacer (use w/6094-1)
6078	Pulley Spacer
6087	Engaging Rod
6089	Engaging Handle
6092	Mower Blade
6093-1	Outer Hub Assembly
6094-1	Deck Hub Casting
6095-1	Center Shaft
6097-1	Outer Shaft
6100	Outer Shaft Key
6101	Center Shaft Key
6107	Deck Pin
6108-1	Center Hub Assembly
6109	V-Belt
6110	V-Idler Pulley
6111	Deck Drive V-Belt
6113	Blade Washer
6119	Caution Decal
6123	Engaging Idler Stud Bushing
6127	Deflector Weldment
6134	Engaging Spring
6135	$\frac{5}{16}$ " Turnbuckle
6136	Engaging Cam Weldment
6148A	Connecting Arm Assembly
6151	Mower Deck Bearing
8005	Fiberglass Repair Kit (limited shelf life)

**OWNER INFORMATION**

Date Mower Purchased \_\_\_\_\_ Mower Model Number \_\_\_\_\_

Mower Purchased from \_\_\_\_\_  
dealer name & address

Mower Serial Number \_\_\_\_\_ Transaxle Serial Number \_\_\_\_\_

Oil changed this date:

1. \_\_\_\_\_

4. \_\_\_\_\_

2. \_\_\_\_\_

5. \_\_\_\_\_

3. \_\_\_\_\_

6. \_\_\_\_\_

Engine tuned this date:

1. \_\_\_\_\_

3. \_\_\_\_\_

2. \_\_\_\_\_

4. \_\_\_\_\_

# The Amazing Transaxle!

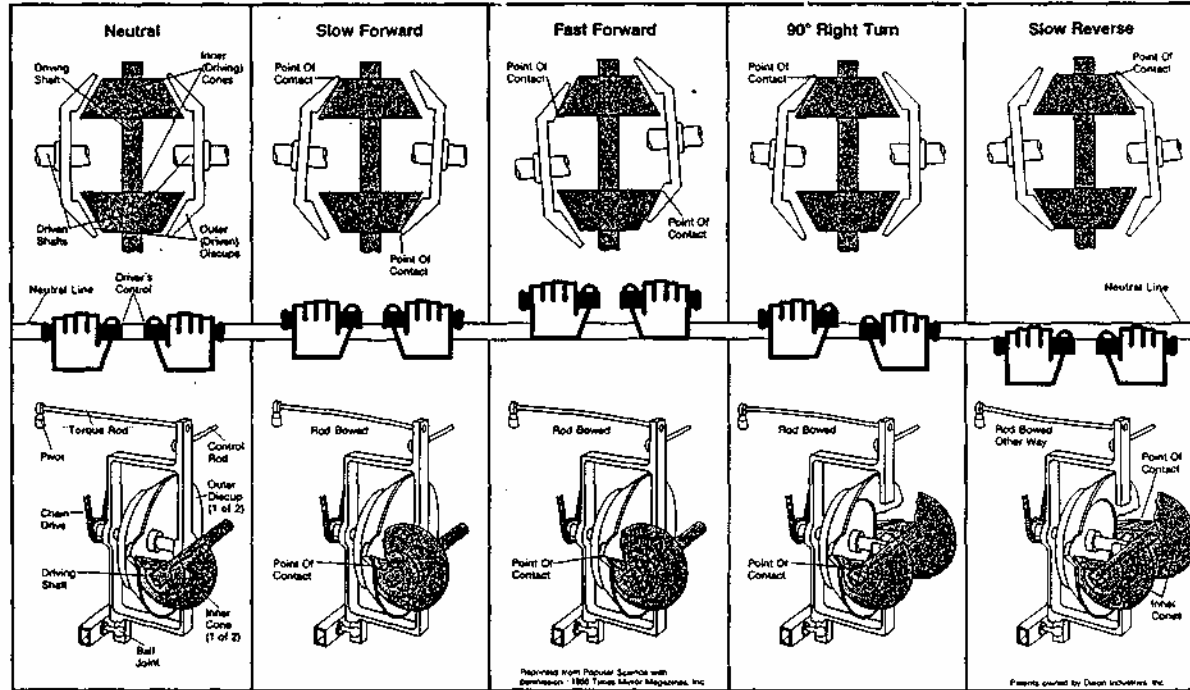

**DIXON**®

**DIXON INDUSTRIES, INC. BOX 494, COFFEYVILLE, KANSAS 67337**

**ZTR**®

Form No. 4089-1279 Litho in U.S.A.

© DIXON and ZTR are registered trademarks of Dixon Industries, Inc.