



Operator's Manual



7000 SERIES ZTR® MOWERS

2000

IMPORTANT - READ CAREFULLY

The Dixon[®] ZTR[®] Mower is both easy and fun to operate. However, any power mower must be operated properly to be safe. It is not a toy or a recreational vehicle. Before you start to use the mower, read the operator's manual carefully and become completely familiar with the controls.

The information in this operator's manual applies to all Dixon[®] ZTR[®] 7000 Series Commercial Mowers. Your Dixon dealer will gladly answer any questions.

See your dealer for warranty service, parts and repairs.



DIXON INDUSTRIES, INC.
A BLOUNT International Inc. Co.
PO BOX 1569
COFFEYVILLE KS 67337 0945
316 251 2000

BLOUNT

INDEX

SAFETY	Pages	4-9
WARRANTY POLICY	Page	10
SPECIFICATIONS	Page	11
SEAT ADJUSTMENT	Page	12
CONTROLS	Pages	13-16
OPERATION INSTRUCTIONS	Pages	17-22
CARE AND MAINTENANCE	Pages	23-33
STANDARD SERVICE PARTS LIST	Page	34
TROUBLESHOOTING	Pages	35-36

7000 Series
Part No. 13091-0500

SAFETY

RIDING LAWNMOWERS, IF IMPROPERLY OPERATED, CAN CAUSE SERIOUS INJURY OR DEATH

The most common causes of injury to the operator or bystander...

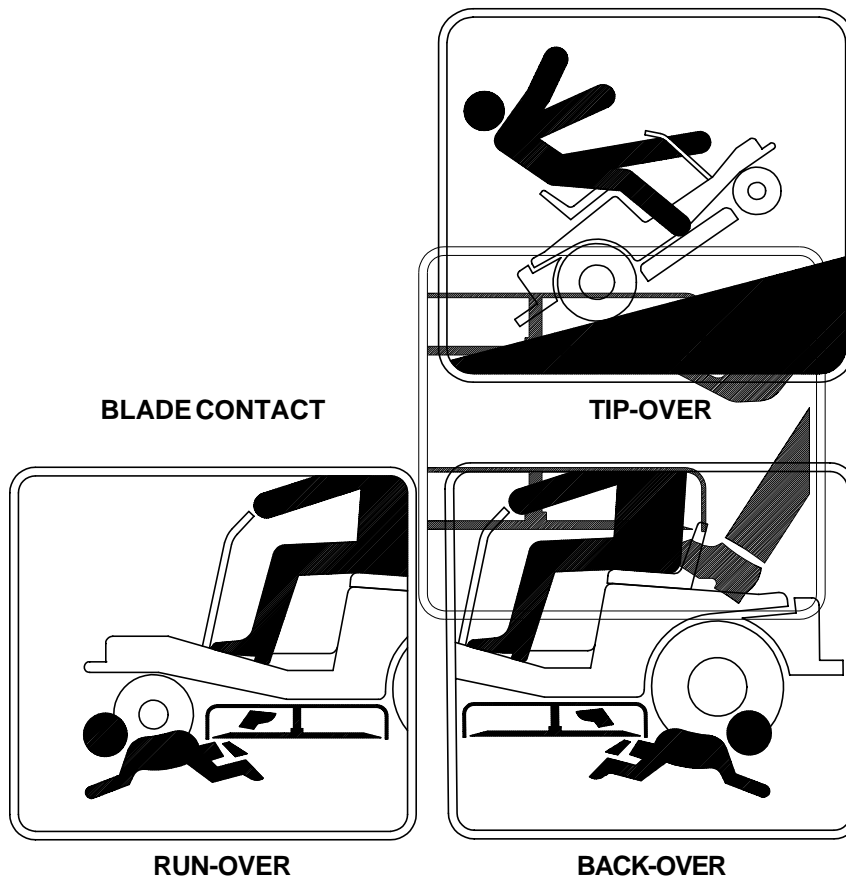

...read and understand this manual to prevent injuries.

SAFETY



Safety Alert Symbol

When you see this symbol,
BE ALERT to the potential for injury.

Follow recommended safety precautions and safe operating practices.



Danger

indicates an imminently hazardous situation which, if not avoided, will result in death or serious injury.



Warning

indicates a potentially hazardous situation which, if not avoided, could result in death or serious injury.



Caution

indicates a potentially hazardous situation which, if not avoided, may result in minor or moderate injury. It may also be used to alert against unsafe practices.

 **SAFETY**

***This cutting mower is capable of amputating hands & feet,
and throwing objects.
Failure to observe the following safety instructions could result in
serious injury or death.***

GENERAL OPERATION:

- Read, understand, and follow all instructions in the manual and on the mower before starting.
- Only allow responsible adults, who are familiar with the instructions, to operate the mower.
- Clear the area of objects such as rocks, toys, wire, etc., which could be picked up and thrown by the blade.
- Be sure the area is clear of other people before mowing. Stop mower if anyone enters the area.
- Never carry passengers.
- Do not mow in reverse unless absolutely necessary. Always look down and behind before and while backing.
- Be aware of the mower discharge direction and do not point it at anyone. Do not operate the mower without either the entire grass catcher or the deflector in place.
- Slow down before turning.
- Never leave a running mower unattended. Always turn off blades, set parking brake, stop engine, and remove key before dismounting.
- Turn off blades when not mowing.
- Stop engine before removing grass catcher or unclogging chute.
- Mow only in daylight or good artificial light.
- Do not operate the mower while under the influence of alcohol or drugs.
- Watch for traffic when operating near or crossing roadways.
- Use extra care when loading or unloading the mower into a trailer or truck. Do not ride the mower when loading & unloading.
- Always wear safety goggles or safety glasses with side shields when operating mower.
- Data indicates that operators, age 60 years and above, are involved in a large percentage of riding mower-related injuries. These operators should evaluate their ability to operate the riding mower safely enough to protect themselves and others from serious injury.
- Follow the manufacturer's recommendation for wheel weights or counterweights.
- Maintain or replace safety and instruction labels, as necessary.

 **WARNING:** *The engine exhaust from this product contains chemicals known to the State of California to cause cancer, birth defects or other reproductive harm.*

 **SAFETY****SLOPE OPERATION:**

Slopes are a major factor related to loss-of-control and tip-over accidents, which can result in severe injury or death.

All slopes require extra caution.

If you cannot back up the slope or if you feel uneasy on it, do not mow it!

DO

Mow across the slope with your Dixon ZTR - never up or down.

Remove obstacles such as rocks, tree limbs, etc.

Watch for holes, ruts or bumps. Uneven terrain could overturn the mower. Tall grass can hide obstacles.

Use slow speed. Tires may lose traction on slopes even though the brakes are functioning properly.

Use extra care with grass catchers or other attachments. These can change the stability of the mower.

Keep all movement on the slopes slow and gradual. Do not make sudden changes in speed or direction.

Avoid starting or stopping on a slope. If tires lose traction, disengage the blades and proceed slowly down the slope.

If front wheels lift off the ground, pull the levers back to stabilize the mower.

DO NOT

Do not turn on slopes unless necessary, and then, turn slowly and gradually downhill, if possible.

Do not mow near drop-offs, ditches, or embankments. The mower could suddenly turn over if a wheel is over the edge of a cliff or ditch, or if an edge caves in.

Do not mow on wet grass. Reduced traction could cause sliding.

Do not try to stabilize the mower by putting your foot on the ground.

Do not use grass catcher on steep slopes.

 **SAFETY****CHILDREN:**

Tragic accidents can occur if the operator is not alert to the presence of children.

Children are attracted to lawn mowers and the mowing activity.

NEVER assume children will stay where they were last seen.

Be alert to avoid accidents.

- Keep children out of the mowing area and under the watchful care of another responsible adult.
- Be alert and turn mower off if a child enters the area.
- Before and during backing, look behind and DOWN for small children.
- Never carry children. They may fall off and be seriously injured or interfere with safe mower operation.
- Never allow children to operate the mower.
- Use extra care when approaching blind corners, shrubs, trees, or other objects that may obscure vision.

 **SAFETY*****SERVICE:***

- Use extra care in handling gasoline and other fuels. They are flammable and vapors are explosive.

Use only an approved container.

Never remove gas cap or add fuel with the engine running. Allow engine to cool before refueling. Do not smoke.

Never refuel the mower indoors.

Never store the mower or fuel container inside a building where there is an open flame.

If fuel is spilled on clothing, change clothing immediately.

To prevent fire and explosion caused by static electricity:

Never fill containers inside a vehicle or on a truck or trailer bed with a plastic liner. Always place containers on the ground away from your vehicle before filling.

When practical, remove gas-powered equipment from the truck or trailer and refuel it on the ground. If this is not possible, then refuel such equipment on a trailer with a portable container, rather than from a gasoline dispenser nozzle.

If a gasoline dispenser nozzle must be used, keep the nozzle in contact with the rim of the fuel tank or container opening at all times until fueling is complete. Do not use a nozzle lock-open device.

- Never run a mower inside a closed area. The exhaust fumes are toxic.
- Keep nuts and bolts tight, especially blade attachment bolts, and keep equipment in good condition.
- Never tamper with safety devices. Check their proper operation regularly.
- Keep mower free of grass, leaves, or other debris buildup. Clean up oil or fuel spillage. Allow mower to cool before storing.
- Stop and inspect the equipment if you strike an object. Repair, if necessary, before restarting.
- Never make adjustments or repairs with the engine running.
- Grass catcher components are subject to wear, damage, and deterioration, which could expose moving parts or allow objects to be thrown. Frequently check components and replace with original equipment parts, when necessary.
- Mower blades are sharp and can cut. Wrap the blade(s) or wear gloves, and use extra caution when servicing them.
- Batteries contain sulfuric acid. To prevent burns avoid contact with skin, eyes and clothing. To prevent a fire or explosion keep sparks and open flames away from battery.
- Before disconnecting the negative (-) ground cable, make sure all switches are OFF.

DIXON LIMITED WARRANTY POLICY - COMMERCIAL MODELS

Models 6000 & 7000

WARRANTY: Home Owner Application: This Dixon Warranty term is for a period of two (2) years from date of purchase. Commercial Application: Dixon mowers used for commercial application are warranted for 1 year from the date of purchase. Commercial use is specified as use other than, or in addition to, mowing at owner's primary place of residence.

DIXON ZTR MOWERS ARE WARRANTED AGAINST DEFECTS IN MATERIALS AND WORKMANSHIP AND PROVIDES FOR REPLACEMENT OR REPAIR OF PARTS INCLUDING LABOR COSTS. THIS WARRANTY IS SUBJECT TO THE FOLLOWING CONDITIONS AND LIMITATIONS:

1. Warranty applies only to original retail purchaser of new and unused mowers and accessories.
2. All Dixon warranty must be accomplished by authorized Dixon dealers and in accordance with Dixon warranty policy and allowances. All warranty claims must be approved by Dixon Industries, Inc.
3. Battery warranty: Limited to 90 days from date of purchase.
4. Accessories Warranty (Grass Catchers, Snow Blades, Covers, etc.): Limited to 90 days from date of purchase.
5. Warranty does not apply to damage in transit or incidents of misuse, negligence, accidents, or alteration. The use of parts or components other than those supplied by Dixon Industries, Inc. **VOIDS ALL WARRANTY.**
6. The following items are not covered by this warranty policy:
 - (a) Pick up and delivery charges for transportation of mower to and from an Authorized Dixon dealer's place of business.
 - (b) Routine maintenance or adjustments.
 - (c) Belts/cutting blades/HydroGear filters.
 - (d) Engines--All engines used on Dixon ZTR mowers are warranted by each individual engine manufacturer.
 - (e) Any costs or expense of providing substitute equipment while repair work is being performed on a warranted mower.
7. There is no other express warranty. Implied warranties, including those of merchantability and fitness for a particular purpose, are limited to the same duration of the express warranty, and to the extent permitted by law any and all implied warranties are excluded. Liabilities for consequential damages under any and all warranties are excluded.

SPECIFICATIONS

7000 Series

CHASSIS:	11 GA - rectangular tube
BODY:	Folded sheet metal.
SEAT:	Designed for operator comfort with padded back and arm rests. Seat is adjustable fore and aft.
MOWER DECK:	2 Decks are available. Both decks are made of 10 GA fabricated welded construction with 7 GA reinforcement plate. 3 blades combine for either a 52" or 60" cut width. Cut height approximately 1.5" to 5" via 7 position lift handle.
BLADE DRIVE:	Electric clutch
DRIVE SYSTEM:	Each rear wheel is independently driven by a HydroGear BDU-10L Series 70 hydrostatic transmission. The hydrostatic transmissions, in turn, power a fully enclosed HydroGear gearbox.
ENGINE:	25HP Kohler Command, 4-Cycle, V-Configuration, Overhead Valve, Air-Cooled, Gasoline, Vertical Shaft, Aluminum Head, and Crankcase with Cast Iron Liners, Full Pressure Lubrication/Full Flow Filter, Pulse-type Fuel Pump, Fixed Jet Carburetor w/Smart-Choke, Electronic Ignition, In-Line Fuel Filter, Dual Element Air Cleaner.
STARTING SYSTEM:	Electric by key switch operation with safety interlocks on parking brake and blade drive clutch.
TIRES:	Front 13-5.00x6 Rear 23-9.50x12
RECOMMENDED TIRE PRESSURE:	Front 12 lbs. Rear 12 lbs.
CAPACITIES:	Fuel - 11 gallons (approx) Hydrostat oil tank - 3 quart with in-line 40 micron filter Hydrostat oil recommendation, refer to page 36 Engine - 2 qts. SAE 10W30 (with filter)
DIMENSIONS:	Width 61"(52" Deck), 69-1/2"(60" Deck) Height 43" Length 81" (52" Deck), 81" (60" Deck) Weight 915 lbs.(48" Deck), 916 lbs.(60" Deck)
NOTE:	Additional information provided in service instructions under the individual component.

SPECIFICATIONS SUBJECT TO CHANGE WITHOUT NOTICE

SEAT ADJUSTMENT INSTRUCTIONS

Model 7025

1. Grasp seat slide adjuster and move it into adjustment position.
2. Slide seat forward or backward.
3. Release seat slide adjuster.

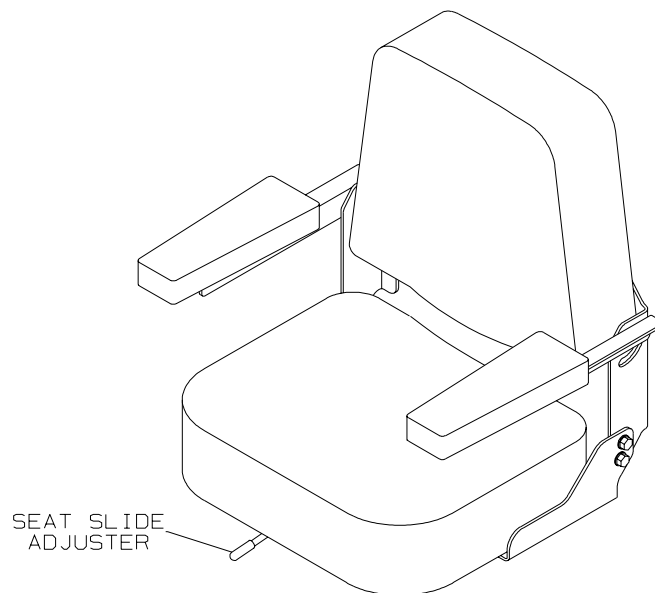

CONTROLS

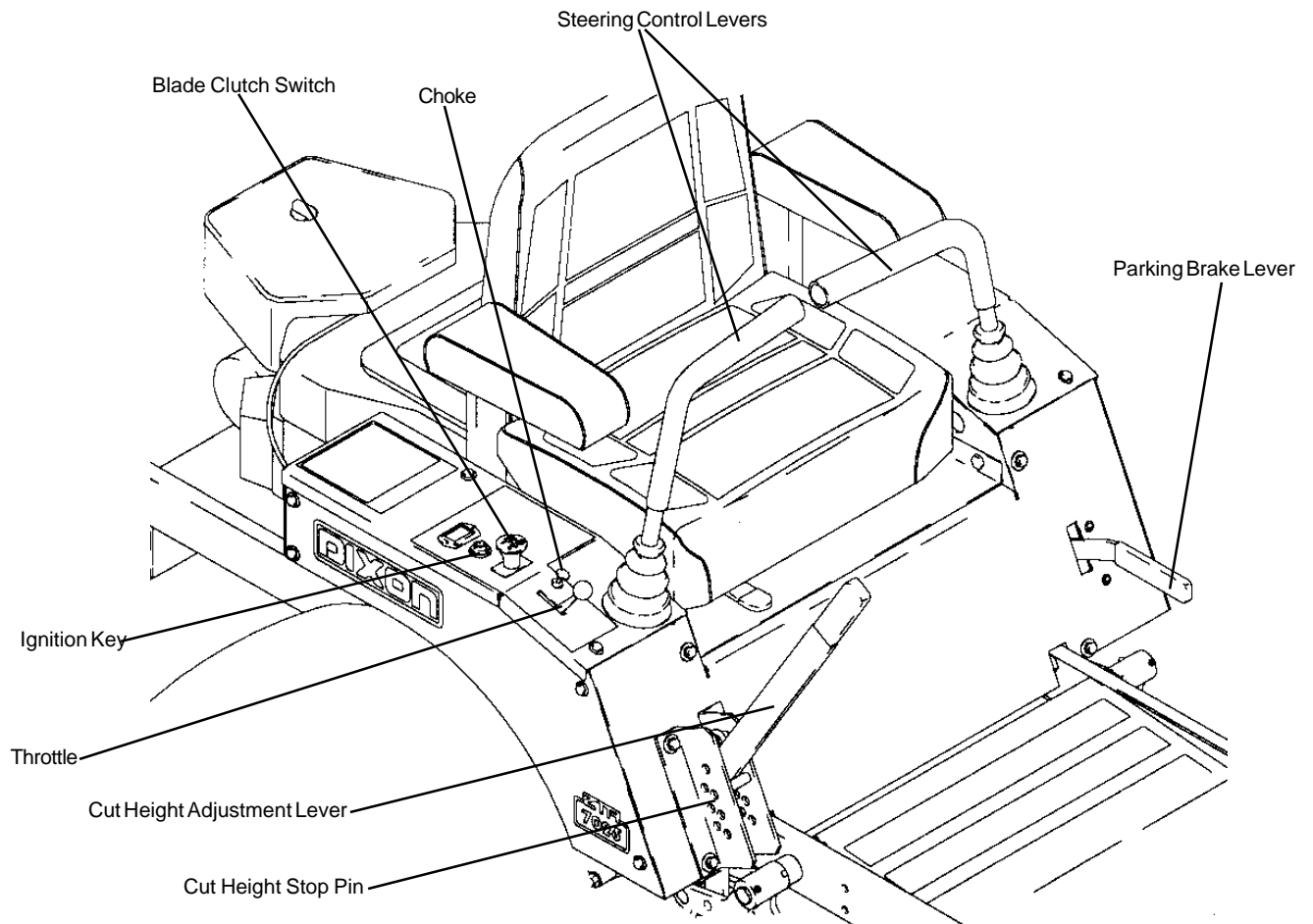

CONTROLS

PARKING BRAKE:

The parking brake is designed to hold the mower from moving and is *not* intended for use in stopping the mower while it is in motion.



CAUTION Engage parking brake before starting engine

TO SET PARKING BRAKE:

The hand operated parking brake is located at *left* hand side of mower.

To engage brake, pull upward.

To release brake, move lever downward.

NOTE: *Always set parking brake before dismounting.*

Release parking brake before moving mower.

HYDRO-GEAR DRIVE SYSTEM:

Allows the mower to turn on its own axis (zero turning radius).

Each lever controls one side of the mower.

NOTE: *The pressure required to operate the mower is very light.*

CONTROLS

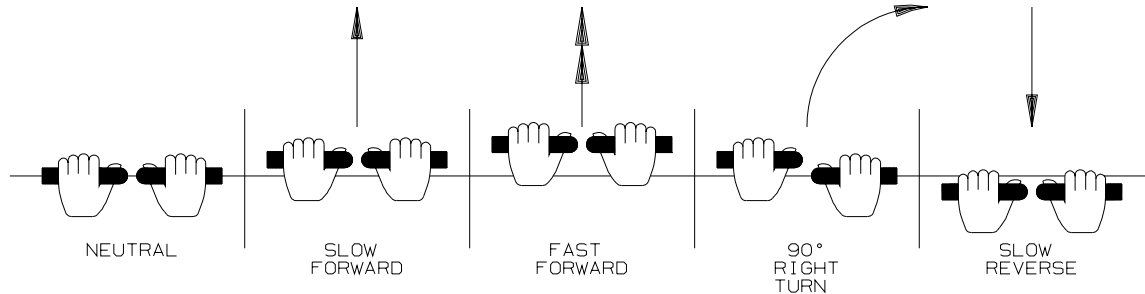

TO GO FORWARD:

From neutral position, gently push both drive levers forward.

To increase speed, move levers farther forward.

TO GO BACKWARD:

From neutral position, gently pull both drive levers toward you.

TURNING:

Turning is controlled by moving one drive lever slightly forward or rearward of the other.

To turn left, move left lever rearward of the right lever.

To turn "square corners" move lever of desired direction to neutral.

To turn on mower's own axis (zero turning radius) stop and move one lever to reverse position and the other to forward position.

BRAKING:

To brake mower, move both levers in direction opposite of travel, release levers to neutral, set parking brake. Park only on level surfaces.

CHOKE CONTROL LEVER:

Located on control panel to operator's right.

Used to start a cold engine.

THROTTLE CONTROL LEVER:

Located on control panel to operator's right.

Controls engine speed, slow to maximum.

While mowing, throttle control should be set to the **MAXIMUM** or wide open setting to insure adequate cooling of the engine and to maintain mower deck blade speed.

CONTROLS

BLADE DRIVE:

Located on control panel, on operator's right.

To engage blades:
Pull up on the switch.

To disengage blades:
Push down.

MOWER DECK CUT HEIGHT LIFT LEVER:

Located to the right and front of operator.

Controls the cutting height.

Seven positions of adjustment.

Lift lever and place stop pin in hole corresponding to the desired height. Let lever rest on the pin stop.

NOTE: Always use high position for transport.

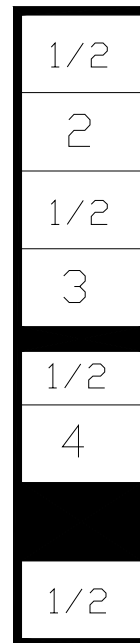

OPERATION INSTRUCTIONS

The safe and successful operation of the Model ZTR 7000 Series will depend upon the operator having the correct knowledge of all controls used on the mower and making good judgements about the terrain to be mowed.

NEVER allow anyone to operate the mower without complete knowledge of all controls and their functions.

During initial operation, "learning to drive", set throttle at slow speed.

Sound judgement by the owner will prevent accidents.

BEFORE OPERATING MOWER:

1. Read engine manufacturer's operating and maintenance instructions.
2. Discuss proper maintenance with your dealer.
3. Read and observe all safety instructions on your mower and in the manual.
4. Check engine oil.
5. Check gas cap to be sure it is in place.
6. Be sure parking brake is on.
7. Mower blade drive is off.
8. Know how to stop engine. (Turn key to off position)

OPERATION INSTRUCTIONS



TESTING OF SAFETY INTERLOCK SYSTEMS:

Do not operate mower if safety switches are not operating properly.

Your Zero Turning Radius Mower is equipped with switches interlocked for your safety.

1. The mower blades must be disengaged before the engine will start.
2. The steering control levers must be in neutral "OUT" position before the engine will start.
3. The engine will stop if the mower blade clutch is engaged when the operator leaves the driver's seat.
4. The engine will stop if the steering control levers are not in the neutral "OUT" position when the operator leaves the driver's seat.
5. The engine will stop if the brake is "SET" and the steering control levers are moved to the "IN" position.
6. The engine will stop if the brake is "SET" and the mower blade clutch is engaged.

BLADE DRIVE SWITCH TEST: (Electric Clutch)

- a. With the electric blade drive switch turned on and the parking brake in "ON" position, engine should not turn over or attempt to start when key switch is moved to the start position.
- b. In a SAFE AREA away from bystanders, start the engine, place throttle setting at maximum or full. Engage the blade drive through the electric clutch switch. Raise weight slightly off of seat. *Engine should stop.*
- c. *If any Safety Check fails, do not operate the mower until the system has been checked and repaired by an Authorized Dixon ZTR Dealer.*

OPERATION INSTRUCTIONS

STARTING INSTRUCTIONS: Cold Engine

1. Pull choke control lever up.
2. Push throttle control lever to 1/2 setting.
3. Insert ignition key and turn to "Start" position. When engine starts, release ignition key. Key will return to "Run" position.
4. Once engine starts to *warm up*, slowly push choke control lever down to the fully closed position.
5. Move throttle control lever to the *wide open or maximum* setting for actual operation of the mower deck.
6. Engine must be operated at *wide open or maximum* setting to insure adequate lubrication, cooling and cut quality of the mower deck.

NOTE: Model ZTR 7025 will require a slightly longer warm up period using partial choke settings.

OPERATION INSTRUCTIONS

STARTING INSTRUCTIONS: Engine has been operated.

1. Move throttle control lever to 1/4 to 1/2 setting.
2. Insert ignition key and turn to "Start" position. When engine starts, release ignition key. Key will return to "Run" position.
3. Move throttle control lever to *wide open or maximum* setting for actual operation of the mower deck.

NOTE: Model ZTR 7000 Series may require partial choke setting to start even if the engine has been operated for a period of time.

4. Engine must be operated at *wide open or maximum* setting to insure adequate lubrication, cooling and cut quality of the mower deck.



CAUTION

DO NOT operate the engine in an enclosed area due to the harmful exhaust gas produced.

NOTE: On initial operation, set throttle at slow speed.

Engine cannot be restarted when blade is engaged.

Safety switches stop engine when operator leaves seat while mower blade is engaged.

Always turn engine off when leaving mower.

OPERATION INSTRUCTIONS

In order to achieve optimum cutting performance, please read and follow the tips listed below.

Additional information can be found in the troubleshooting guide beginning on page 35.



CAUTION

Be sure that deflector is properly installed on the discharge chute.

1. Set engine speed control to the wide open or full setting.
2. *Do Not Attempt To Cut Grass When It Is Wet.* Wet grass will clog the underside of the deck and discharge area.
3. If the grass is tall, place the mower deck cut height lever in the top or second notch. "Initially" overlap cutting swaths instead of a full swath with each pass. Some applications may require a second cutting.
4. *Keep The Underside Of The Mower Deck Clean.* Frequent removal of dried grass and dirt will allow the clippings to discharge correctly.
5. *Maintain Sharp Blade(s) Throughout The Cutting Season.*

GRASS HEIGHT SUGGESTIONS:

Correct mowing height can reduce weeds and disease by 50% to 80%

The following grass cut heights are based on adequate moisture conditions and normal thatch buildup in a healthy lawn. Some locations and applications may require slightly different cut heights. If in doubt, consult your local lawn professional for assistance.

Grass Types:	Best Cut Heights:
Zoysia	2" - 2 1/2"
Blue Grass	1 1/2" - 3"
Fescue Blends	1 1/2" - 3"
St. Augustine (Mid South)	1 1/2" - 2"
St. Augustine (Deep South)	3" - 4"
Tifton Bermuda	1 1/2"
Centipede	1 1/2" - 2"
Common Bermuda	1 1/2" - 2"
Bahia/Argentina/Pensacola	2"

OPERATION INSTRUCTIONS

TO FREE WHEEL MACHINE: UNLOCK TRANSMISSION

The transmission release levers are located on each side of the mower behind the rear drive axles and below the engine mounting plate. Lift the levers slightly, push them forward and then down to release the transmission for free wheeling.

To engage the transmissions lift the levers slightly, pull them to the rear and them down.

NOTE: The tractor should never be pulled at more than 2 miles per hours or for any appreciable distance.

CARE AND MAINTENANCE

CAUTION

Before performing any maintenance, turn off engine, allow to cool, remove key and disconnect spark plugs. Use extreme care when working on machinery. Do not wear watch or jewelry. Do not wear loose fitting clothes, and observe all common safety practices with tools.

MAINTENANCE SCHEDULE

Check drive belts	every 50 hours (20 hours break-in)
Check crankcase oil level	before each use
Clean grass from Hydrostat fans and cooling fans	before each use
Check air intake screen	after each use
Clean grass under deck	after each use
Check tire pressure	every 10 hours
Check battery fluid	every 10 hours
Sharpen mower blades	every 10 hours
Clean air filter element	every 25 hours
Check hydrostatic transmission fluid	every 25 hours
Service air filter element.	every 100 hours
Change engine crankcase oil	every 100 hours (5 hours break-in)
Change engine oil filter	every 200 hours
Change hydrostat oil & oil filter	every 500 hours (100 hours break-in)
Replace air filter element	annually or every 500 hours
Check spark plugs	annually or every 500 hours
Service battery.	annually or every 500 hours

CARE AND MAINTENANCE

ENGINE:

For complete maintenance and operating information of the engine, please refer to the maintenance instructions furnished by the engine manufacturer and included in your Zero Turn Radius Mower information packet.

Note: Air intake screen must be kept clean. If plugged, engine may be seriously damaged by over heating.



CAUTION

Battery electrolyte is a poisonous and corrosive sulfuric acid solution. Avoid spilling on skin, eyes and clothing.

BATTERY:

Check the fluid in the battery at frequent intervals.

Keep fluid level above the plates in each cell, using distilled water.

OFF SEASON BATTERY STORAGE:

Identify each cable so cables can be reconnected to correct terminals.

Disconnect cables from terminals.

ALWAYS disconnect ground cable first and reconnect last.

Charge battery.

DO NOT remove battery from mower.

Clean top of battery and terminals with baking soda and water.

TIRES:

Correct tire pressure is essential for efficient operation of the mower. Check tire pressure periodically. Inflate tires to the pressure listed below.

Front tires - 12 lbs.

Rear tires - 12 lbs.

Lug nuts or lug bolts should be checked regularly for tightness.

CARE AND MAINTENANCE



CAUTION

Stop engine, remove ignition key and spark plugs for safety. Wear heavy, thick gloves when holding onto cutter blade, avoid the sharp edge of the blade.

MOWER BLADES:

Check sharpness of mower blades after every 10 hours of operation. To sharpen blades, proceed as follows.

- A. Remove bolt, lock washer, and cup washer mounting blade on shaft. Remove blade.
- B. Blades should be discarded when worn excessively.
- C. Sharpen blade with a hand file, electric grinder or blade sharpener. Wear gloves and eye protection when sharpening. Grind blade at original 25 degree bevel.
- D. Check balance of blade by positioning the blade on a nail or blade balance pedestal. Grind the blade on the end that is heavier until both sides balance.
- E. Install blade, cup washer, lock washer and bolt. Make sure to tighten bolt to 60 ft. lbs.

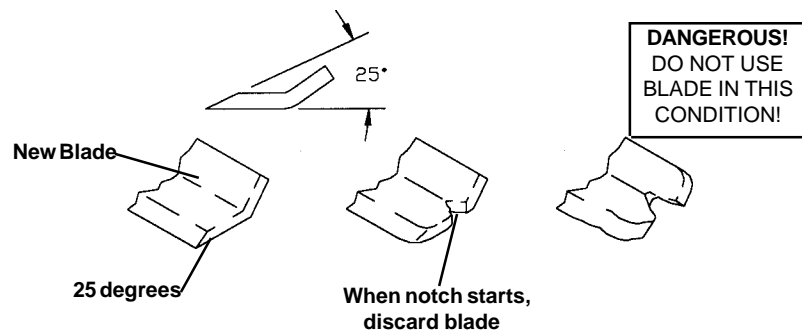

V-BELTS:

There are 3 V-Belts on your Dixon Zero Turning Radius Mower. They should be checked every 50 hours. Replace any belts found to be in poor condition. All belts are equipped with spring loaded belt tighteners and do not require tightening adjustments.

CARE AND MAINTENANCE

LUBRICATION:

- A. Engine: Follow engine manufacturer's recommendation.
- B. Deck spindles: Lubriacte with 3 "shots" only, every 100 hours.
- C. Hydrostatic transmission and filter (follow instructions listed below).

Dirt or water in oil can ruin the hydrostatic transmissions.

CHECKING & REPLENISHING OIL IN HYDROSTATIC TRANSMISSION

Check the oil level in hydrostatic transmission oil reservoir after every 25 hours of usage. Clean the oil reservoir cap and the area around it prior to removal. Check the oil level on the dipstick. The proper oil level should register between the marked hole on the dipstick and the end of the dipstick. Replenish as needed with 20W-50 Motor Oil. **DO NOT OVERFILL.** When checking the oil level, be very careful to keep the reservoir clean.

Change the oil in the reservoir and hydrostat transmission oil filter after the first 100 hours of use. Then every 500 hours after that. Remove the filter and be sure all oil has drained from the reservoir. Replace with new filter and 20W-50 Mobil Super II.

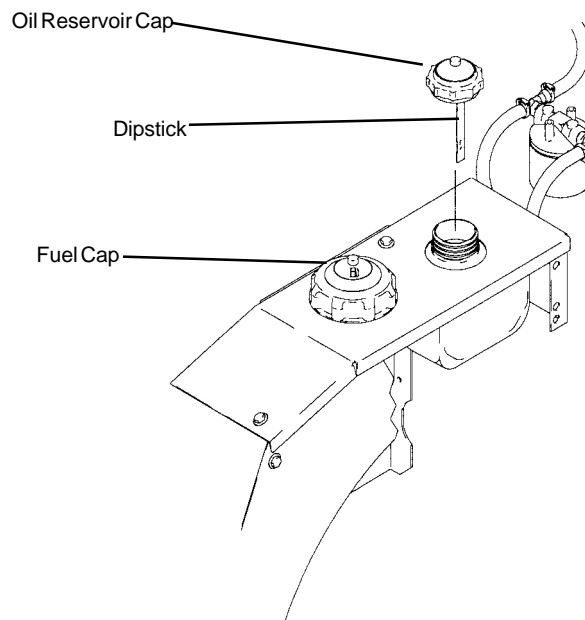

Please dispose of used oil at proper collection centers - protect your environment

CARE AND MAINTENANCE

PARKING BRAKE ADJUSTMENT

With the brake handle in the release position, remove the cotter pin from the castle nut. Insert a 0.010 feeler gauge between the brake disc and the brake puck. Tighten the castle nut with the feeler gauge inserted until the gauge fits snugly between the disc and puck. The gap should not be so tight that the feeler gauge cannot be reinserted after removal. Back the castle nut to the closest pin hole and reinsert the cotter pin. Repeat for other side. See picture below.

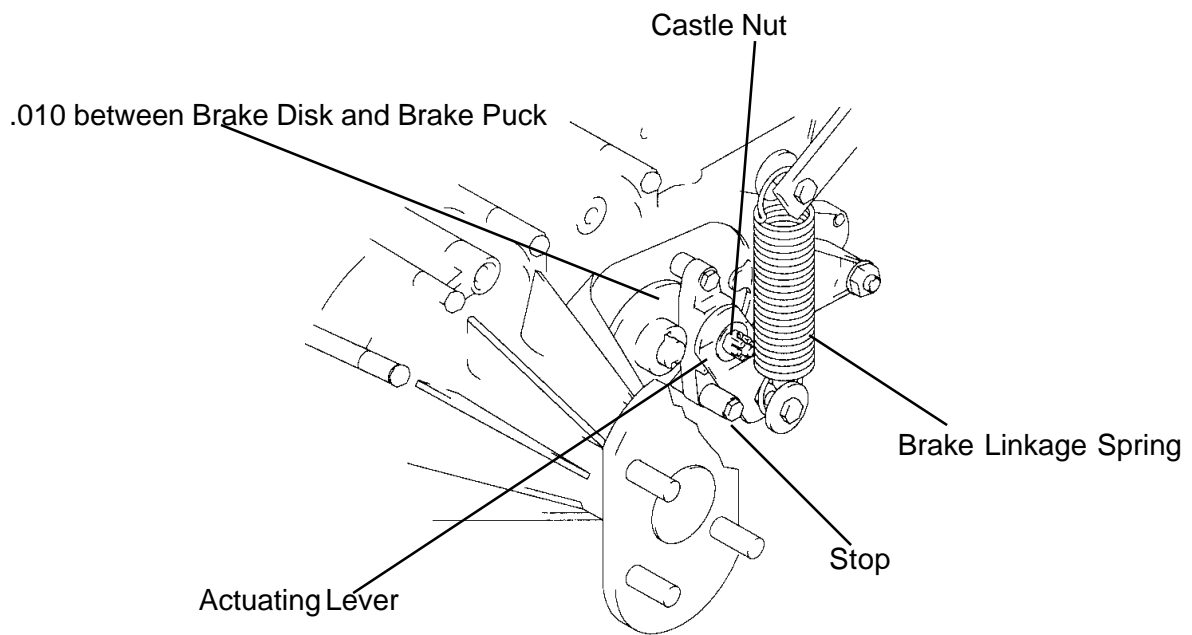

CARE AND MAINTENANCE

HYDROSTATIC TRANSMISSIONS:

Before each use, check to be sure that the cooling fins of the hydrostatic transmissions are clean. Excessive accumulation of oil, dirt, or trash may cause the transmissions to overheat. NEVER WASH ACROSS TOP OF RESERVOIR WITH WATER OR STEAM. Fill reservoir as required per the maintenance schedule listed in this book.

HYDROSTAT DRIVE BELT REPLACEMENT PROCEDURE:

(The hydrostatic drive is equipped with a manual belt take-up).

- A. Remove the 3/8" locknut, washers, and rubber spacer from the rear of the assembly.
- B. Allow the idler arm/pulley to swing forward towards the front of the mower. Remove old belt if required. Replace with new belt.
- C. With the belt in place on all pulleys, reinsert the rubber spacer, washers, and 3/8" locknut. Tighten 3/8" locknut until rubber spacer is deflected approximately 1/8" to 3/16". Make sure belt is not too tight. Belt deflection or movement should be approximately 1/4" to 1/2" when measured at mid-point between hydro and idler pulley.

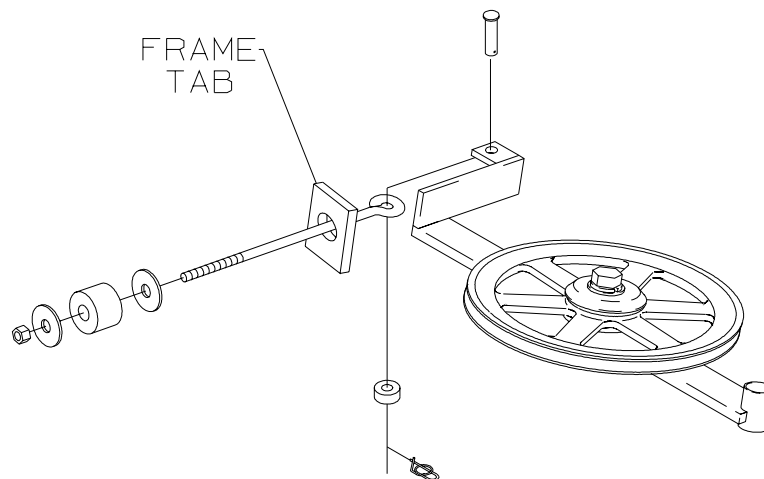

CARE AND MAINTENANCE

STEERING CONTROL ADJUSTMENTS

A. To Adjust Neutral:

1. Remove the fender skirts from each side of the machine.
2. Block up the unit so that the Drive Wheels are off the ground.
3. Start the engine and run at a fast idle with the Steering control levers in the "out" position.
4. Loosen the locknuts tightened against the rod end ball joints in the Upper Linkage Assembly.

NOTE: One of these is a left hand nut and will have to be turned backwards.

5. Adjust the Neutral Position by turning the rod in the upper linkage until the wheel stops turning.
6. Retighten the nuts on the Upper Linkage Assembly and check to see that the drive wheel is still not turning.
7. Repeat steps 1-6 for the other side.
8. Shut off engine before removing the blocks.

B. To Adjust "IN" Position of the Steering Controls:

1. Remove the two front bolts, lockwashers, and washers which hold the fender cap.
2. Pull the boot from the hole in the fender cap, exposing the cast iron lever.
3. Using a 5/32" Allen wrench, turn the setscrew to adjust the stop.
4. Replace the boot into the hole in the fender cap.
5. Replace the two front bolts, lockwashers and washers.

C. To Align Handles:

Sit on the seat and push the control levers full forward and full backward. If the ends do not match, the handles may be adjusted as follows:

1. Locate setscrew stops in the steering control lever base which stop the lever in each direction.

NOTE: The one at the rear is the stop for FWD and the one in the front is the stop for REV.

2. Adjust setscrew stops so that handles line up together when shifted full forward and full reverse.

CARE AND MAINTENANCE

STEERING CONTROL ADJUSTMENTS (continued):

D. Adjusting for Straight Forward Tracking:

In large open area, actuate the control handles into the full forward position. If the mower veers in either direction (left or right) some adjustment is necessary.

1. If the mower veers to the right, then the right hydrostat needs to be sped up. If the mower veers to the left, then the left hydrostat needs to be sped up.
2. Stop the machine and shut off the engine.
3. Slightly loosen the bolt at the lower end of the upper linkage assembly on the side that is slower. Using a 1/8" Allen wrench turn the setscrew 1/4 turn in. It may take several test drives to get the mower to track straight forward.
4. Once the tracking is to the operator's liking, completely tighten the bolt on the control linkage assembly that was loosened earlier.
5. Recheck to make sure neutral adjust has not been effected, see procedure A.

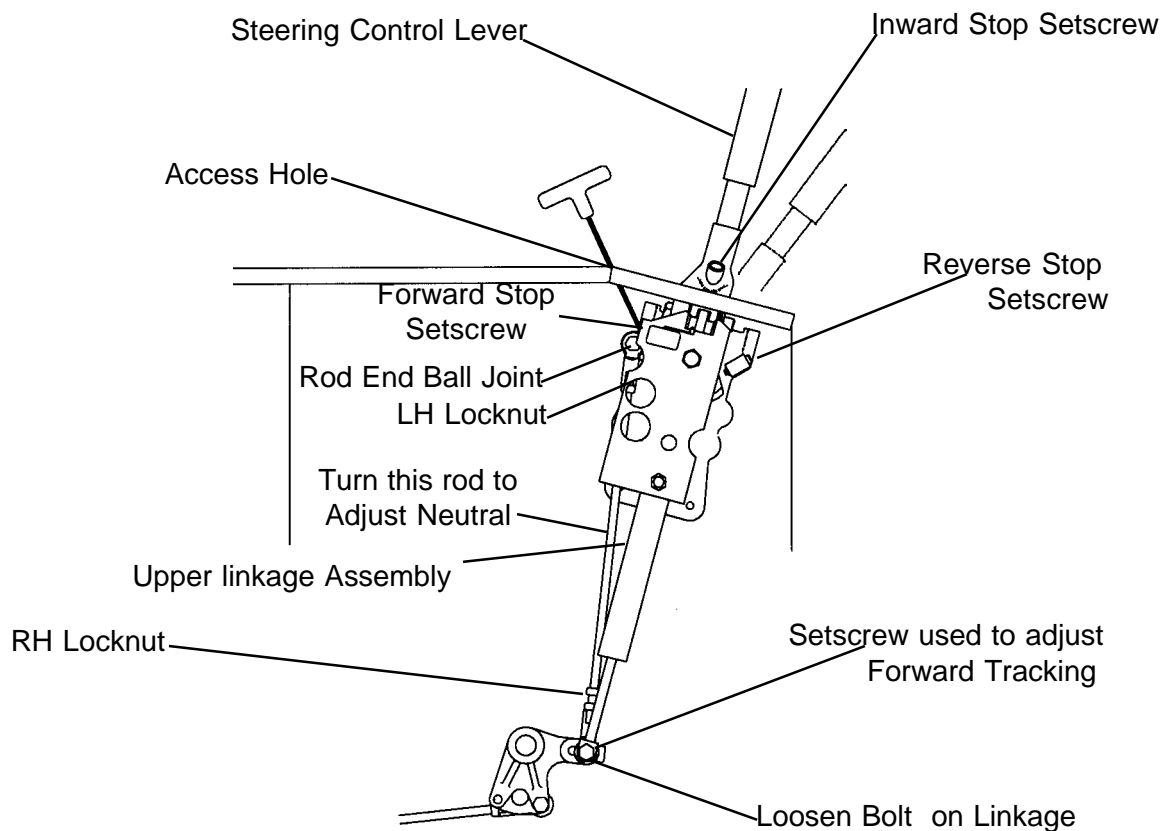

CARE AND MAINTENANCE

LEVELING THE DECK

- A. Set the tire pressure on all four tires.
- B. Move the tractor to a hard, level surface (i.e. concrete or blacktop). Place a 2x4 board under all four corners of the deck shell, just inside of the anti-scalping wheels. Lower the deck down onto the boards. The deck must rest on the boards, not the anti-scalping sheels. Adjust the deck hangers longer or shorter until the deck "just" comes off of the boards. Remove the boards and verify that the deck is hanging on all four deck hangers, re-adjust if necessary. Lock the jam nuts on the deck hangers. (Note: the two rear deck hangers will be easier to adjust in the fender skirts are removed).

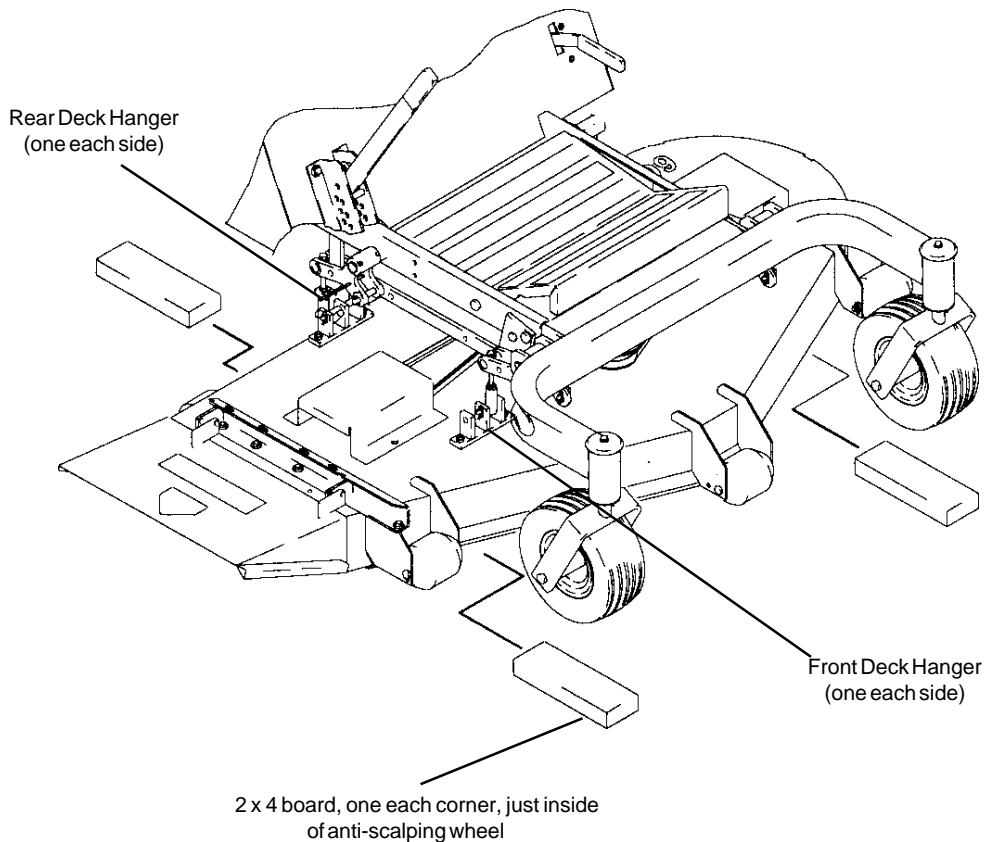

CARE AND MAINTENANCE

PROCEDURE FOR RAISING AND LOWERING THE DECK FOR SERVICING

RAISING THE DECK:

- A. Remove cut height adjustment pin and completely lower the cut height adjustment lever. Re-insert the cut height adjustment pin into the 3-1/2" cut height position (this will lock the cut height adjustment lever into the lowest position).
- B. Flip up the foot deck to allow access to the engine to deck drive belt. Roll the engine to deck drive belt off the center spindle. Hook the engine to deck drive belt onto the bolt protruding out of the top of the foot deck support angle.
- C. Lift the rear corner of the deck and disconnect the rear deck mounting latch. Repeat for the other side.
- D. Position the front caster wheels so they are away from the deck (such as the tractor would be traveling in reverse).
- E. Attach a hoist to the deck lift bolt. lift the nose of the deck until the deck is standing vertical and the deck latch engages.

IMPORTANT NOTE: MAKE SURE THAT THE DECK IS LIFTED FAR ENOUGH FOR THE DECK LATCH TO FULLY ENGAGE THE LOCKING PIN (LOCATED ON THE LEFT SIDE OF THE DECK MOUNTING SUSPENSION). THIS WILL PREVENT THE DECK FROM FALLING DOWN WHEN SERVICING THE UNDERSIDE OF THE MOWER DECK.

LOWERING THE DECK:

- A. While lifting the nose of the deck disengage the deck latch from the locking pin. Push the bottom of the deck towards the rear of the tractor while holding the deck latch so that it clears the locking pin. Lower the deck until it rests on the ground.
- B. Lift the rear corner of the deck and reconnect the rear deck mounting latch. Repeat for the other side.
- C. Roll the engine to deck drive belt back onto the center spindle. Insure that the engine to deck drive belt is installed onto all of the pulleys and idlers in the drive train.
- D. Lower the foot deck down into the operation position.

CARE AND MAINTENANCE

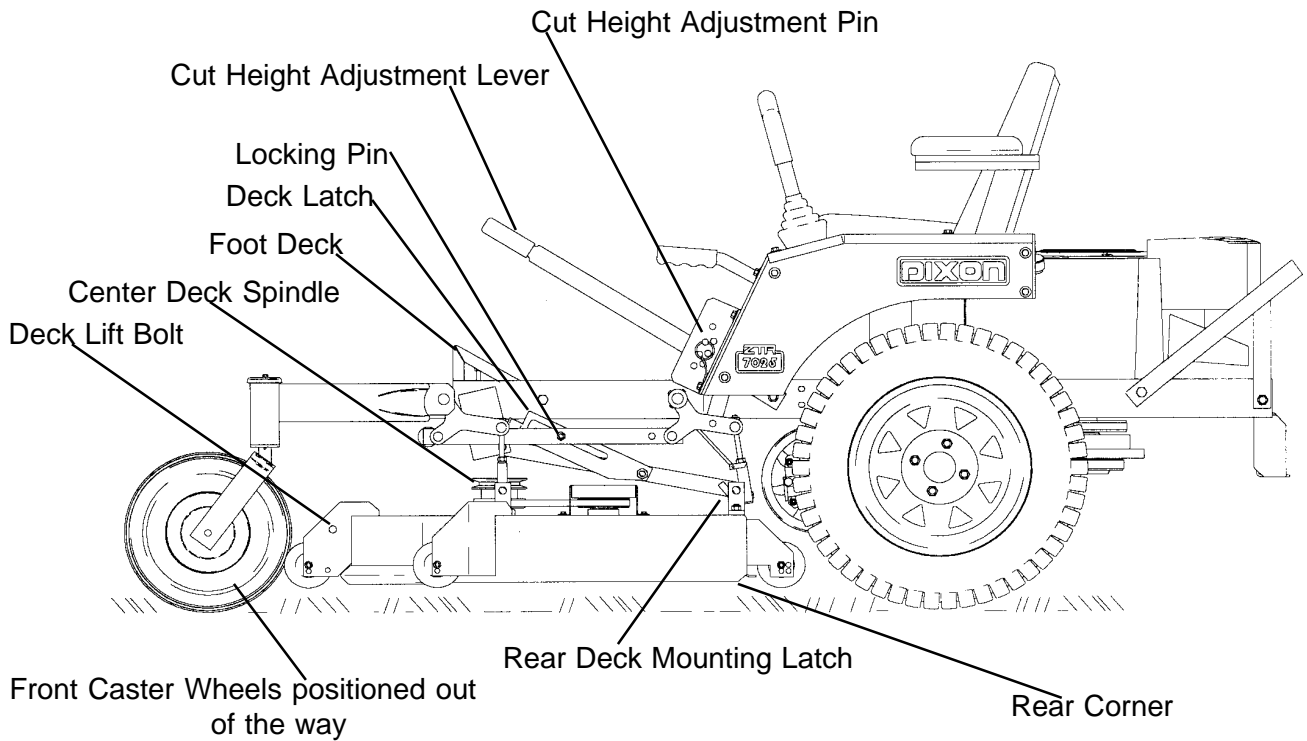

MOWER SHOWN IN OPERATION POSITION

Engine to Deck Drive Belt

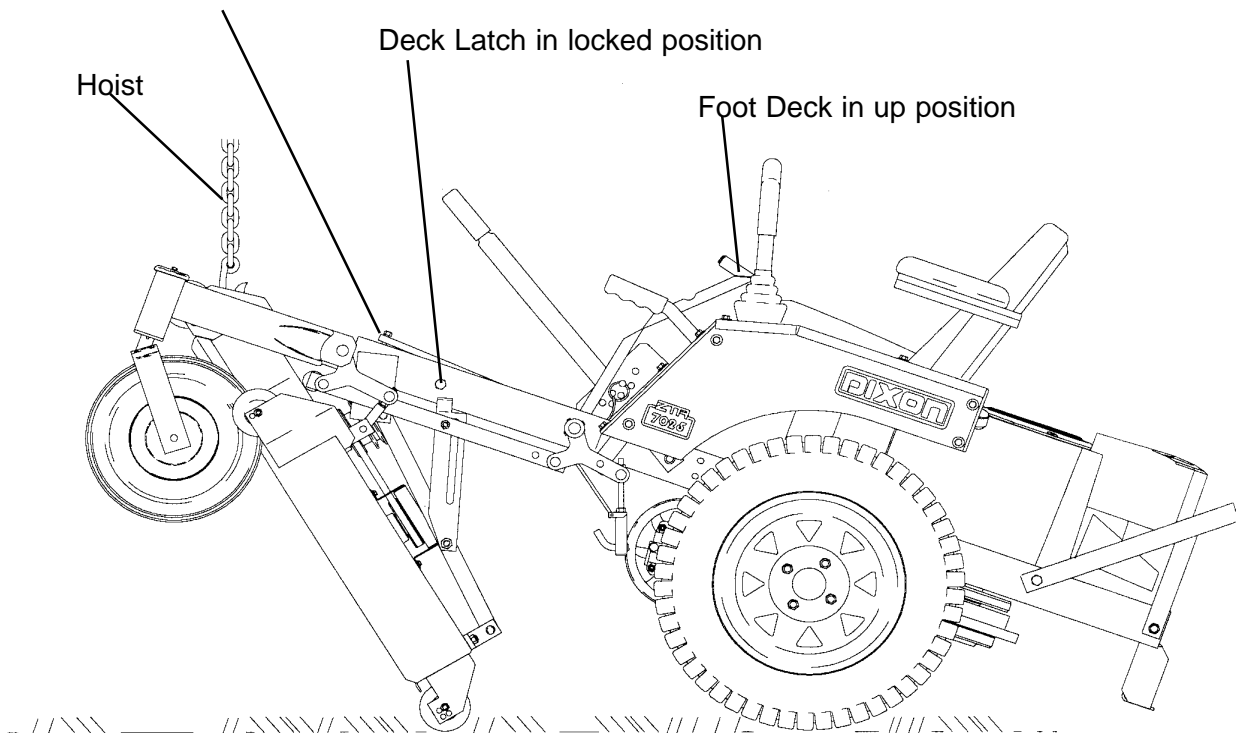

MOWER SHOWN IN SERVICING POSITION

STANDARD SERVICE PARTS LIST

MODEL ZTR 7025:

BLADES:	52" Hi-Lift:	P/N 60532
	60" Hi-Lift:	P/N 60295
	60" Lo-Lift:	P/N 60293
BELTS:	Engine To Mower Deck:	P/N 60497
	Serpentine Belt:	P/N60492(52") P/N 60494 (60")
	Engine To Hydro:	P/N 61593
	Hydrostatic Transmission Filter:	P/N 7252

KOHLER AIR AND OIL FILTER PART NUMBERS:

Refer to engine manufacturers manual for recommendations regarding frequency of service required for engine oil changes and air filter maintenance.

Protect your engine investment, use only original equipment filters.

Model ZTR 7025:	25HP	Pre-Cleaner Foam Element	45083-01-S
		Cartridge Air Cleaner	45083-02-S
		Engine Oil Filter	12050-01-S

IMPORTANT:

Some applications, extreme dirt conditions, or the use of a grass catcher may require that the engine used on the Model ZTR 7025 be fitted with an *OPTIONAL Kohler fresh air filter system*.

Consult your dealer or a Kohler engine service center for additional information.

TROUBLESHOOTING

1. ENGINE WON'T TURN OVER

Mower blades engaged-----disengage blades
Drive not in neutral-----move steering control levers to neutral "OUT " position
Blown fuse-----replace fuse
Dead battery-----charge or replace
Solenoid-----consult dealer
Ignition switch-----consult dealer
Starter-----consult dealer

2. ENGINE WILL TURN OVER BUT WON'T START

No gas-----refuel and/or clean or replace fuel filters
Over or under choked-----adjust choke
Spark plug not firing-----check spark plug
Carburetor maladjustment-----condition and reset gap*/consult dealer
Ignition Switch-----readjust carburetor* or consult dealer for carburetor service

3. HARD TO START ENGINE

Fuel line clogged-----clean fuel line and check fuel filter
Faulty fuel pump-----consult dealer
Spark plug wire loose or grounded-----check spark plug wires
Spark plug(s) faulty or improperly gapped-----check spark plug
Electronic ignition defective-----condition and reset gap*
Dirty or maladjusted carburetor-----consult dealer
readjust carburetor* or consult dealer for carburetor service

4. ENGINE STARTS BUT CUTS OUT

Water in gasoline-----drain old gasoline-replace with new gasoline and /or clean carburetor bowl
Clogged fuel line-----clean carburetor bowl and or check fuel filter
Vent in fuel cap plugged-----clean fuel line
Faulty fuel pump-----check vent
Maladjusted carburetor-----consult dealer
Engine dies when control levers are moved "IN"-----parking brake set -- release brake

5. ENGINE KNOCKS

Low oil level-----check and add oil
Ignition timing off-----consult dealer
Fuel octane too low-----drain and replace with higher octane gasoline
Over heated engine-----shut off engine and allow to cool

*See engine manual for engine adjustments

TROUBLESHOOTING

6. ENGINE SOMETIMES SKIPS AT HIGHER SPEED

Incorrect ignition timing-----Consult dealer
Carburetor maladjusted-----Readjust carburetor
Faulty spark plugs-----Check spark plug or condition and reset gap*

7. ENGINE OVERHEATED

Air intake screen or fins clogged-----Clean Intake screen and fins
Fuel mixture too lean-----Readjust carburetor*
Oil level too low or too high-----Adjust oil level
Improper ignition timing-----Consult dealer
Running engine too slow-----Run engine faster

(NOTE: Always mow at full throttle setting.)

8. ENGINE IDLES POORLY

Carburetor maladjustment-----Readjust carburetor
Improper spark plug gap-----Check and re-gap plug*

9. ENGINE BACKFIRES

Carburetor maladjustment-----Readjust carburetor*

10. ENGINE RUNS BUT MOWER WON'T MOVE FORWARD

Drive belt broken or slipping-----Replace drive belt
Shift linkage cable disconnected-----Reconnect
Transmission shift arm disconnected-----Reconnect
Transmission oil low-----Add oil
Transmission locks in free wheel position-----Put in lock position (see pg. 5)
Hydrostat oil filter plugged-----Replace filter
Bad transmission-----Consult dealer
Gear mating transmission/gearbox disconnected-----Consult dealer

11. MOWER LOSES POWER OR TRANSMISSION OVERHEATS

Hydrostat transmission oil too low or too high-----Add Oil or drain oil as needed
Transmission damage-----Consult dealer
Transmission blowing oil out cap-----Overfilled or water contaminated

12. ENGINE STALLS WHEN BLADES ARE ENGAGED

Operator not on seat-----Sit on seat
Faulty interlock system-----Consult dealer
Bad blade spindle bearing-----Consult dealer
Deck drive belt not properly routed-----Reroute
Blades blocked by foreign material-----Clean under deck

*See engine manuals for engine adjustments

NOTES

NOTES

OWNER INFORMATION



DIXON INDUSTRIES, INC.
ABLOUNT International Inc. Co.
PO BOX 1569
COFFEYVILLE KS 67337 0945
316 251 2000
FAX 316 251 4117



DATE PURCHASED _____

MOWER MODEL NUMBER _____

MOWER SERIAL NUMBER _____

PURCHASED FROM _____

Name

Address

DATE OIL CHANGED:

DATE ENGINE TUNED:



 **WARNING:** *The engine exhaust from this product contains chemicals known to the State of California to cause cancer, birth defects or other reproductive harm.*

Dixon® and ZTR® are registered trademarks of Dixon Industries, Inc.

DIXON INDUSTRIES, INC.
a BLOUNT International Inc. Co.
PO Box 1569
Coffeyville, Ks 67337 0945
316-251-2000

7000 Series
7025
Part No. 13091-0500