

DIXON®

ZTR®
501

Operator's Manual

INDEX

1. SAFETY	Pages 1 - 3
2. WARRANTY POLICY	Page 4
3. SPECIFICATIONS	Page 5
4. SET UP AND SERVICE	Pages 6 - 11
5. OPERATION INSTRUCTIONS	Pages 12 - 13
6. CARE AND MAINTENANCE	Pages 14 - 21
7. TROUBLESHOOTING	Pages 22 - 24
8. PARTS ILLUSTRATIONS	Pages 25 - 28
9. PARTS LIST	Pages 29 - 31
10. ELECTRICAL SCHEMATIC	Page 32

IMPORTANT - READ CAREFULLY

The Dixon ZTR Mower is both easy and fun to operate. However, any power mower must be operated properly to be safe. It is not a toy or a recreational vehicle. Before you start to use the mower, read the operator's manual carefully, and become completely familiar with the controls.

The information in this operator's manual applies to all Dixon ZTR Model 501 Mowers. Your Dixon dealer will gladly provide a check-out ride, and answer any questions.

See your dealer for warranty service, parts and repairs.

DIXON INDUSTRIES, INC.

Box 494

Coffeyville, Kansas 67337-0494



SAFETYRIDING LAWMOWERS, IF IMPROPERLY-OPERATED. CAN CAUSE SERIOUS INJURY.

The following examples are the most, common causes of Injury to the operator or bystander.

1. BLADE CONTACT: The operator or bystander inserts a hand or foot into the discharge chute or under the mower deck and into the path of the cutting blade.
Never run the mower blades when there are people nearby.
Always turn the engine off when cleaning or working around the mower deck.
2. RUN-OVER: This situation occurs when a bystander is run-over or backed over by the mower. The most frequently cited examples are with small children who wander into, or are allowed to play, in an area where the mower is being operated. Never run the mower blades when there are people nearby, especially children. Young children should be indoors and watched by an adult.
Always look behind you before backing up.
- 3- TIP-OVER: This occurs when the mower tips over, usually sideways or to the rear. This situation is due to operation of the mower on steep inclines or near a drop off.
Mow across the slope to slightly uphill.
Mow slopes when the grass is dry and watch for bumps, holes and other obstacles.
Test the slope with the blades off. A good rule of thumb is "Don't mow on a slope you can't back up".
Stay clear of drop-offs, especially if they are on the down side of a slope.
4. THROWN OBJECTS: The fast spinning mower deck blade can strike stones or other objects which can be hurled into the path of a bystander. To prevent this from happening, never remove the safety discharge chute from the mower deck, or operate the mower when other people are around.
5. FIRES: Most accidents of this type occur during re-fueling of the mower or placing the mower in a storage situation. The exhaust system and related engine components operate at very high temperatures which can ignite any fuel spilled on or near them. Always allow the mower to cool before re-fueling or placing in storage.
6. OPERATION BY CHILDREN: This mower is not a toy or recreational vehicle.
Never allow children to operate the mower in any manner or to ride as a passenger.

NOTE: The six examples are the most frequently cited injury causing situations. Please review all the safety precautions outlined on the following pages prior to operation of the mower. Our aim is to enhance the safe and satisfactory use of this product.

SAFETY REMINDERS: READ CAREFULLY BEFORE OPERATION

1. Wear appropriate, safe clothing when mowing - close fitting jeans or slacks and heavy leather or safety shoes with rough soles. Never operate this mower with bare feet or open sandals.
2. Do not operate on wet or slippery grass.
3. Always mow at the slowest speed that will cut satisfactorily.
4. Keep hands and feet away from the blade at all times.
5. Keep persons clear of the discharge chute. Do not operate mower unless deflector is in place.
6. When mowing hills or slopes, use extreme caution. Reduce speed, do not make sudden starts, stops or turns.
7. Always disengage blades before taking the mower across walks or objects that project above the surface.
8. Stay alert for holes, rocks and roots in the terrain, and other hazards. Keep away from drop-offs.
9. When the mower is not in use, turn the engine off and remove key. Never leave the engine running unattended. Your Dixon mower is equipped with a weight-sensitive switch that kills the engine when operator leaves the seat while blades are engaged.

"Test this important safety feature before each time mower is used. This may be done by starting engine, engaging blades and then rising slightly from seat. If engine does not stop, see your dealer for necessary repair."

10. Before adjusting or servicing your mower, turn off the engine and let it cool. Be sure all moving parts are stopped. Never run the 501 with the body open.
11. Never run the engine indoors; the fumes are dangerous. , :
12. Before backing your Dixon Mower; stop, turn around and look.
13. Handle gasoline with care - it is highly flammable.
 - A. Use approved gasoline container.
 - B. Never remove the fuel cap of, or add gasoline to, a running or hot engine, or an engine that has not been allowed to cool after running. Never fill the tank indoors and always clean up spilled gasoline.
 - C. Never store the mower, with gasoline in the tank, inside the building where fumes may reach an open flame or spark. Allow the engine to cool before storing in any enclosure.
14. Never lift lawnmower by the body; lift only by the frame.
15. Never carry passengers.

SAFETY REMINDERS: (continued)

16. Use care when pulling loads or using heavy equipment.
 - A. Use only approved drawbar hitch points.
 - B. Limit loads to those you can safely control.
 - C. Do not turn sharply. Use care when backing.
17. Watch out for traffic when crossing or near roadways.
18. Keep the mower in good operating condition, and keep safety devices in place and working.
19. Keep all nuts, bolts and screws tight to be sure the mower is in safe working condition.
20. To reduce fire hazard, keep the engine free of grass, leaves or excessive grease,
21. The mower should be stopped and inspected for damage after striking a foreign object or if it starts vibrating, and any damage should be repaired before restarting and operating the mower.
22. When mowing, proceed as follows:
 - A. Mow only in daylight or in good artificial light.
 - B. Shut the engine off when removing the grass catcher or unclogging chute.
 - C. Check the blade mounting bolts for proper tightness at frequent intervals.
 - D. Never operate the machine when using medication or under the influence of alcohol or drugs.

Warranty Policy:

Each new Model 501 is warranted against manufacturing defects in material and workmanship under normal use and service for a period of (1) year or (400) hours from date of purchase and is extended to the original retail purchaser of the mower only.

Obligation:

Under this warranty policy Dixon Industries, Inc. shall be limited to the replacement to the original purchaser of any part or parts, which, within the warranty period shall be shown to be defective due to faulty workmanship or materials at the factory.

What is NOT covered by Dixon Industries, Inc.:

1. TRANSPORTATION CHARGES: Any charges by the dealer or other parties for transportation of the mower to or from the dealers place of business, also known as pick up and delivery.
2. ENGINES: The warranty policy and procedures for any engine used on our mowers is the responsibility and obligation of the individual engine manufacturer. As such, Dixon Industries, Inc. assumes no responsibility for either the policies or procedures of said manufacturers.
3. BELTS AND BLADES: Our warranty does not apply to the blades or belts used on our mowers due to the very nature of the function they perform and to the elements they are exposed to.
4. ROUTINE MAINTENANCE: Adjustments or any type of oil or grease used on the mower.
5. TIRES: Warranty extended by tire manufacturer.
6. PEERLESS GEAR BOX: Warranted for a period of (90) days from date of purchase of Tecumseh Products Company.
7. NEGLIGENCE: Any failure caused by negligence, improper use or abuse on part of owner or operator.

Who is authorized to perform warranty service?

Any authorized Dixon ZTR dealer can perform repairs under warranty on our mowers. If warranty repairs are needed, please contact the selling dealer first. If, due to circumstances beyond your control, you are unable to obtain repairs by the selling dealer, contact the customer service department of Dixon Industries, Inc. for assistance.

Product updates or improvements:

We reserve the right to make changes in design or improvements on our products without imposing any obligation upon ourselves to install the same on products heretofore manufactured.

SPECIFICATIONS

Chassis: 11 GA - rectangular tube.

Body: Two piece - made of DR acrylic reinforced with fiberglass, color fast, scratch and impact resistant. Front body contains access panels for battery service and engine to mower deck belt removal. Rear body tilts up to allow service on the entire drive system.

Seat: Ergonomically designed for operator comfort by use of high density closed cell foam, contoured back rest and arm rests. Seat is adjustable fore and aft.

Mower Deck: 12 GA stamped steel construction, (3) blades, 50" cut width, cut height 1" to 4" via 7 position lift handle. Self cleaning design smoothly curved front, aides discharge of grass.

Blade Drive: Warner electric clutch.

Drive System: {2} Sundstrand BDU - 10 L hydrostatic transmissions driven by a permanently lubricated peerless gear box.

Engine: 18 HP Briggs and Stratton twin cylinder 1C with cast iron sleeves and ducted air flow.

Starting System: Electric by key switch operation with safety interlocks on parking brake and blade drive clutch.

Tires: Front 11 x 4.10 x 5 smooth tread. Rear 20 x 10 x 8 turf savers.

Capacities: Fuel - 4.8 gallons total (dual tanks) with fuel gauges.
Hydrostat oil tank - 3 quart with inline 10 micron filter.
Hydrostat oil recommendation - name brand SAE (10-W-30) motor oil.

Dimensions: Width - 60"
Height - 45"
Length - 72"
Weight - 624 lbs.

NOTE: Additional information provided in service instruction under the individual component.

SPECIFICATIONS SUBJECT TO CHANGE WITHOUT NOTICE.....

SET UP AND SERVICE

1. Seat assembly instructions.
2. Upper control lever installation.
3. Mower deck installation.
4. Deck leveling procedure.
5. Final preparation.

SEAT ASSEMBLY INSTRUCTIONS

1. Assemble seat as shown in picture. Do not fully tighten the bolts which secure left and right arm rest brackets to seat bottom until seat back and tool box are installed. This will aid alignment of all parts.
2. Place seat assembly on rear body cover, connect seat safety switch.
3. Insert the (2) rear studs of the seat slide into the rear holes of the body cover. Firmly hold seat assembly against body cover with one hand while rear body is raised to fully open position. Continue to hold seat against body to prevent damage to seat safety switch wiring.
4. Install (1) flat washer and (1) nylok nut on (1) of the rear studs extending through body cover and seat frame, tighten a few threads to hold seat assembly in place.
5. Position seat on front holes and install all remaining washers and nylok nuts. Tighten all nuts fully.

SEAT ASSEMBLY INSTRUCTIONSSEAT PACKAGE

KEY	QTY	PART NO.	DESCRIPTION
1	1	4416	SEAT BOTTOM ASSEMBLY
2	1	4385	SEAT BACK
3	2	4400	ARM REST
4	1	4401	ARM REST BRACKET L.H.
5	1	4402	ARM REST BRACKET R.H.
6	1	4257	UTILITY BOX ASSEMBLY
7	14	3020	5/16 STD. FLAT WASHER
8	14	3224	5/16-18 x 3/4 HHB GR5 W/NYLOK
9	4	3205	5/16-18 HEX NUT W/NYLOK
* 10	2	3722	FIBRE WASHER
* 11	2	3033	1/2" FLAT WASHER - NARROW
* 12	2	3035	1/2-13 HEX JAM LOCKNUT
* 13	2	3578	NYLON BUSHING

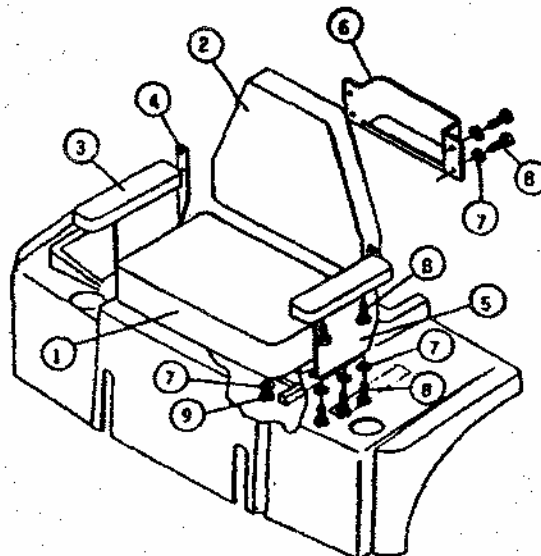

* NOTE: HARDWARE FOR CONTROL LEVER ASSEMBLY

UPPER CONTROL LEVER INSTALLATION

1. Raise rear body cover to fully open position.
2. Insert left upper control lever on swivel plate.
3. Install fiber washer and jam nut.
4. Proper tightness or tension on jam nut is achieved when swing out movement of upper control levers requires some pressure. Levers should not fall to the side or be sloppy in movement.
5. Repeat procedure on right side.

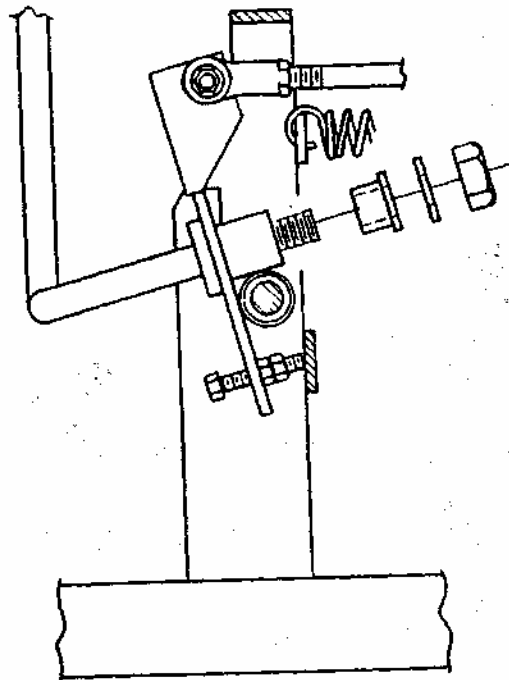

1. To remove front body from chassis, disconnect headlights and remove acorn nut in middle of body.
2. Install rear hanger rods on lift frame, as shown in the diagram. Slide lift plate on hanger rods, small holes in lift plate will face rear of mower, install bushings and start nylok nuts on each hanger rod until approximately 1/4 inch of threads are exposed.
3. Position mower deck under chassis.
4. Place lift lever in 3rd hole from highest cut, position #5 on quadrant.
5. Using (1) of the deck support rods, insert the rod at the corner of the lift frame and the front of the mower chassis in the groove provided on the lift frame. Pry backwards on the lift frame enough to connect the brake link into the hole on the tab of the lift lever. This will allow for belt installation in step #7.
6. Raise mower deck at the rear and slide (1) of the deck support rods through the mower deck lift plate and the tabs of the mower deck. "Note" A length of 2 x 4 board turned on end and placed under the mower deck for support will make this task easier if the installation is being done by one person, due to the weight of the mower deck.
7. Raise front of mower deck and slide front support rod through lift frame and tabs on mower deck. Install hair pin clips on front and rear support rods.
8. Move lift lever to lowest cut position, install engine to mower deck drive belt on top center pulley. Check belt routing after installation to make certain that belt is centered in groove of electric clutch pulley.
9. Move lift lever toward high cut position and remove brake link from hole on lift lever.
10. Install deflector chute on mower deck by using nuts and bolts provided. Never operate mower without deflector chute in place.

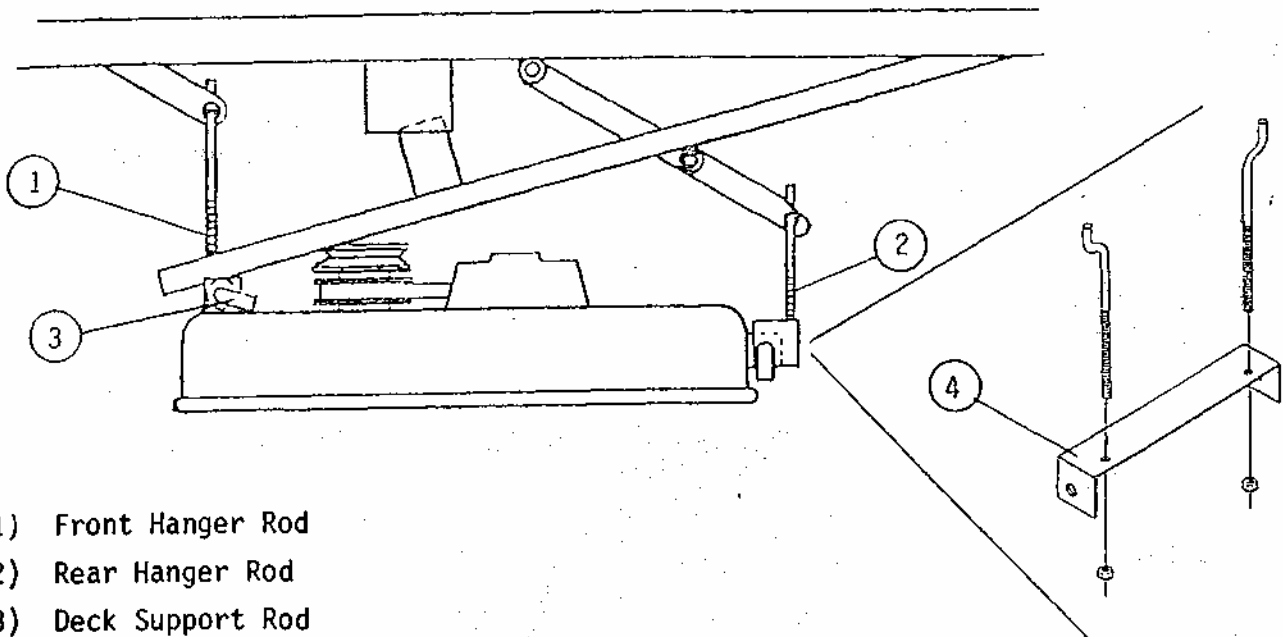

- (1) Front Hanger Rod
- (2) Rear Hanger Rod
- (3) Deck Support Rod
- (4) Lift Plate

MOWER DECK LEVELING PROCEDURE

Leveling Principals:

- A. There are a total of (4) threaded adjusters which will control the attitude or pitch of the mower deck. The adjusters have lock nuts on the bottom which can be turned up or down to raise or lower the front and rear of the mower deck. Deck should be level or pitched slightly higher in rear.

Leveling the Deck:

- A. Place the mower on a smooth level surface, check tire pressures to insure the mower has a correct stance. Inflate tires as required:
 Front - (40 - 46 lbs. maximum)
 Rear - (20 - 24 lbs. maximum)
- B. Remove the discharge chute from the mower deck. Rotate or turn each outer blade tip to align with the edge of the deck or side to side.
- C. Measure from the surface up to the bottom of the blade tip on the discharge side of the mower deck. Retain this measurement. Move to the opposite side and check that measurement is the same. If adjustment is required, turn the nut on the bottom of the front threaded adjuster up or down until both side to side measurements are equal. Retain measurement.
- D. Rotate or turn both outer blades to align with the deck in a front to rear manner. Move to the left rear threaded adjuster, "left rear is designated from operator position on the mower". Turn adjuster nut up or down until rear of mower deck is positioned level to 1/8th of an inch higher than the side to side measurement. At this time, the mower deck will hang or be suspended on (3) points. Move the right rear adjuster and take out the slack which will be present by turning adjuster lock nut up. Confirm the measurement used on the left rear of the deck. Re-install discharge chute.

NOTE:

This will place the mower deck in a base measurement position. Additional adjustment may be required to achieve desired cut for the type of grass or conditions being mowed.

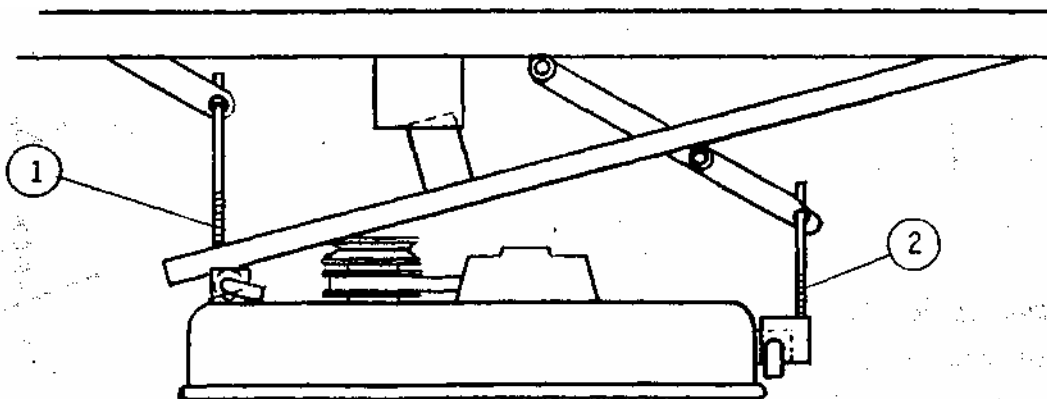

(1) - (2) Adjustment Points

FINAL PREPARATION

1. Remove battery from chassis.
 2. Fill each cell with electrolyte (acid) to ring at bottom of fill cap.
 3. Allow battery to sit for (10) minutes, re-check acid level and top off any cells that are low.
 4. Trickle charge battery using a charger of less than (6) amps until all cells are gassing freely. Hydrometer readings may be taken, if desired.
 5. Install permanent battery caps and wash any accumulated acid from battery before re-installation on chassis.
 6. Observe proper battery polarity when re-connecting leads on chassis. Always connect positive lead first.
-

Engine Service:

1. Final preparation of engine should be completed using engine service manual provided with mower.
-

Initial Start and Hydrostat Transmission Check:

1. Final hydrostat checks have been performed at the factory, however, it is necessary to check that the pressure relief bypass on each hydrostatic transmission is completely released before attempting to drive mower.
2. Each hydrostat has a bypass relief pin located at the bottom front of the unit. A stop plate is provided to allow the mower to be rolled around without complete servicing of the unit. To accomplish this, the stop plate must be positioned to depress the bypass relief pin. If the stop plate is depressing the pin, loosen the lock nut on the stop plate and rotate the stop plate outward which will allow the pin to pop out to the fully extended position. Tighten lock nut on stop plate at this point.

OPERATION INSTRUCTIONS

The safe and successful operation of the Model (501) will depend upon the operator having the correct knowledge of all controls used on the mower and making good judgments about the terrain to be mowed. Never allow anyone to operate the mower without complete knowledge of all controls and their functions.

Sound judgment by the owner will prevent accidents.

Controls and their functions. All controls described from operators position.

PARKING BRAKE:

The parking brake used on the Model (501) is designed to hold the mower from moving and is not intended for use in stopping the mower while it is in motion. An additional safety feature of the parking brake is that the engine cannot be started unless the brake is applied.

THE HYDROSTATIC DRIVE SYSTEM:

Allows the mower to turn on its own axis (zero radius). Each lever controls one side of the mower. The pressure required to operate the mower is very light and a minimum of 1/2 hour should be spent simply driving the mower in a non-mowing application to gain the confidence necessary to mow like a pro.

LEVER MOVEMENTS:

No shifting or clutching required.

TO GO FORWARD:

Release parking brake. From neutral position, gently puch both drive levers forward; to increase speed, move levers farther forward.

TO GO BACKWARD:

From neutral position, gently pull both drive levers toward you.

TURNING:

Turning is controlled by moving one drive lever slightly forward or rearward of the other. To turn left, move left lever rearward of right lever. To turn "square corners" move lever of desired direction to neutral. To turn on mower's own axis (zero radius) reduce speed and move one lever to reverse position and the other to forward position.

BRAKING:

To brake mower, move both levers in direction opposite of travel, release levers to neutral, set parking brake. When stopping on incline, it may be necessary to hold slight pressure on levers in direction opposite of slope until parking brake is set.

GROUND SPEED:

Ground speed (controlled by movement of hand levers) must be carefully controlled for safety and best mowing results. Never operate at high speed in unfamiliar areas or on slopes.

CHOKE CONTROL LEVER:

Used to start a cold engine. (Engine has not been operated for a length of time) Located on control panel to operators right.

OPERATION INSTRUCTIONS (continued)

THROTTLE CONTROL LEVER:

Control's engine speed. (Engine should be operated at full throttle when used in a mowing application, this will insure adequate cooling of the engine as well as maintaining mower deck blade speed) Located on control panel on operators right.

MOWER DECK CUT HEIGHT LIFT LEVER:

Controls the cutting height of the mower deck. Seven positions of adjustment in which the very top, or highest notch, is used for transporting the mower in a non-mowing situation. Located in front of operator on the right side of mower.

BLADE DRIVE:

To engage the mower deck cutter blades, lift switch up lightly and push forward. To disengage blades, pull switch backward. Switch is clearly marked "on and off".

LIGHT SWITCH:

The headlights are activated by pushing the switch forward. Failure to turn off the lights, once the engine is stopped, will result in rapid discharge of the battery.

FUSE BLOCK:

Protection of the electrical system is by (1) 10 AMP fuse. To remove the fuse for inspection, push down and turn cap to the left. If fuse burns quickly, please consult your dealer for inspection and repair. Never attempt to by-pass the fuse by any method.

CARE AND MAINTENANCE - MODEL 501

This portion of the Model 501 owners manual deals with normal service items which can be performed by the owner. Please remember that if you are in doubt as to the correct service procedures to be followed, these and other service situations can be handled by a Dixon ZTR Dealer who is familiar with the service of your mower.

NOTE:

The disassembly and repair of the Sundstrand BDU 10 L hydrostatic transmissions is best left to a qualified Sundstrand repair and service facility. These repair centers are equipped with the necessary tools and service information to accurately perform all service required. Due to the precision nature of these transmissions, field repairs cannot be recommended.

MAINTENANCE SCHEDULE:

To insure a long and trouble free service life on all the components used on the Model (501) a regular and thorough maintenance schedule should be followed. As with any type of precision made equipment, a certain amount of initial bedding in or seating of the components will take place. The following items should be checked after the first (10) hours of operation and on a weekly basis, or each (40) hours of use:

1. Drive system chains, belts and controls.
2. Mower deck belts
3. Tire pressures.
4. Hydrostat oil.
5. Tightness of all nuts and bolts.

Refer to engine service manual provided with your mower for maintenance schedules and procedures to be used on the engine.

CARE AND MAINTENANCE - MODEL 501

MOWER DECK SERVICE: CUTTER BLADE REMOVAL - BELT TENSION.

"CAUTION" The removal of the cutter blades for either sharpening or replacement is best accomplished by removing the deck assembly from the mower. Do not attempt to raise or lift the front of the mower unless proper safety equipment is available to support the mower. If you do not have the necessary equipment, entrust this task to your dealer.

DECK REMOVAL:

1. Remove front belt access cover from body. Stand in front of the mower, grasp lift quadrant lever, with left hand. Move lever to align with the (5th) hole from the bottom on the quadrant plate. At this time, connect brake link into hole on lift lever. Move lift lever toward lowest cut position and remove belt from the top of center deck hub assembly.
 2. Remove the hair pin cotter pins from the ends of the deck support rods. Slide deck support rods from deck while supporting deck assembly with a suitable brace, or by the use of an assistant to hold the deck while rods are removed. Slide deck from under chassis.
 3. Reverse procedure to re-install deck assembly.
-

CUTTER BLADE REMOVAL:

1. Carefully place deck assembly in a manner which will allow access to the blade bolts. Hold blade from turning while bolt is removed from the center of each hub assembly. "Caution" wear heavy, thick gloves when holding onto cutter blade, avoid the sharp edge of the blade.
 2. When re-assembling blades to hub assemblies, fully tighten blade bolts to a minimum of (35 ft. lbs.) torque. The use of air impact tools is recommended for installation to insure bolt tightness.
-

BELT TENSION:

1. The engine to mower deck drive belt on the Model (501) is automatically held in proper tension by springs which push the deck assembly forward, and does not require any additional adjustment to be made. Both the belt and the idler system should be periodically inspected due to the nature of the job they perform.
2. Serpentine deck belt tension is maintained by a manual adjustment rod which is located on the top of the mower deck assembly. Proper belt tension is critical to insure cut quality. If adjustment is required, tighten lock nut on adjustment rod until belt free play or movement between pulleys is approximately 1/4 of an inch.

CARE AND MAINTENANCE - MODEL 501

DRIVE SYSTEM ADJUSTMENTS: Hydrostat Chains - Belts - Cable - Controls

Refer to the diagrams on the following pages for the location of adjustment points.

- Step 1. Loosen the front and rear mounting bolts of the hydrostat, turn the rear adjustment bolt downward, which will tension the final drive chain to the rear wheel. Chain is correctly tensioned when at a point mid-way between the sprockets chain free play or movement is approximately 1/16th of an inch up and down. Re-tighten mounting bolts.
- Step 2. Loosen the (2) bolts which secure the front chain adjustment, refer to diagram, turn the front adjustment bolt downward using a 5/16th alien wrench. Correct tension is as in step #1. Re-tighten bolts.
- Step 3. Repeat above procedures on opposite hydrostat.
- Step 4. Tighten the (2) J-bolts on the T-box mounting plate until each belt has 1/8th to 1/4th of an inch free play or movement at a mid-point between the pulleys on the hydrostats and T-box.
- Step 5. Position parking brake lever in the off or disengaged position. This will allow the belt idler used on the engine to T-box to swing fully and apply tension to the belt. At this time, check that the cable which pulls the idler to a neutral position has approximately 1-1/2 to 2 inches of free play. If adjustment is required, loosen the lock nuts on the cable block and turn cable sleeve in or out to achieve desired measurement. Re-tighten lock nuts. "NOTE" Cable must have the above dimension with parking brake released or drive belt may slip, causing a loss of power.
- Step 6. Neutral adjustment must be checked at this time which will require the engine to be started and the parking brake released. Swing upper control levers outward and into neutral slots, start engine, use caution when releasing parking brake as mower may tend to creep or move prior to re-adjustment of neutral settings on each hydrostat. If adjustment is required, loosen lock nuts at each end of the control rods and back off the tension bolt on each spring block. Turn control rod in or out until neutral is obtained on each hydrostat. Re-tighten lock nuts and tension bolts on spring blocks.
- Step 7. Stop engine, move levers to drive position. Lightly push each upper control lever forward until a resistance is felt on the lever. At this time, check that the forward lever stops are hitting against stop block. "NOTE: Do not allow levers to travel to completely forward without hitting stop blocks as damage to hydrostats could result. If adjustment is required, loosen lock nut on lever stop and turn bolt in to allow lever to hit the stop before resistance is felt in the hydrostat.
- Step 8. Start engine. Drive mower forward and observe driving condition. If mower tends to pull to either side, re-adjust lever stop on fast side to slow that hydrostat down and even out the ground speed. Do not speed up slow side as over stroking of the hydrostat could result in damage to the unit. If upper control levers are slightly off-set after this adjustment, they can be realigned by bending them into alignment.

(1) HYDROSTAT MOUNTING BOLTS

(2) THREADED ADJUSTERS TO TENSION CHAINS

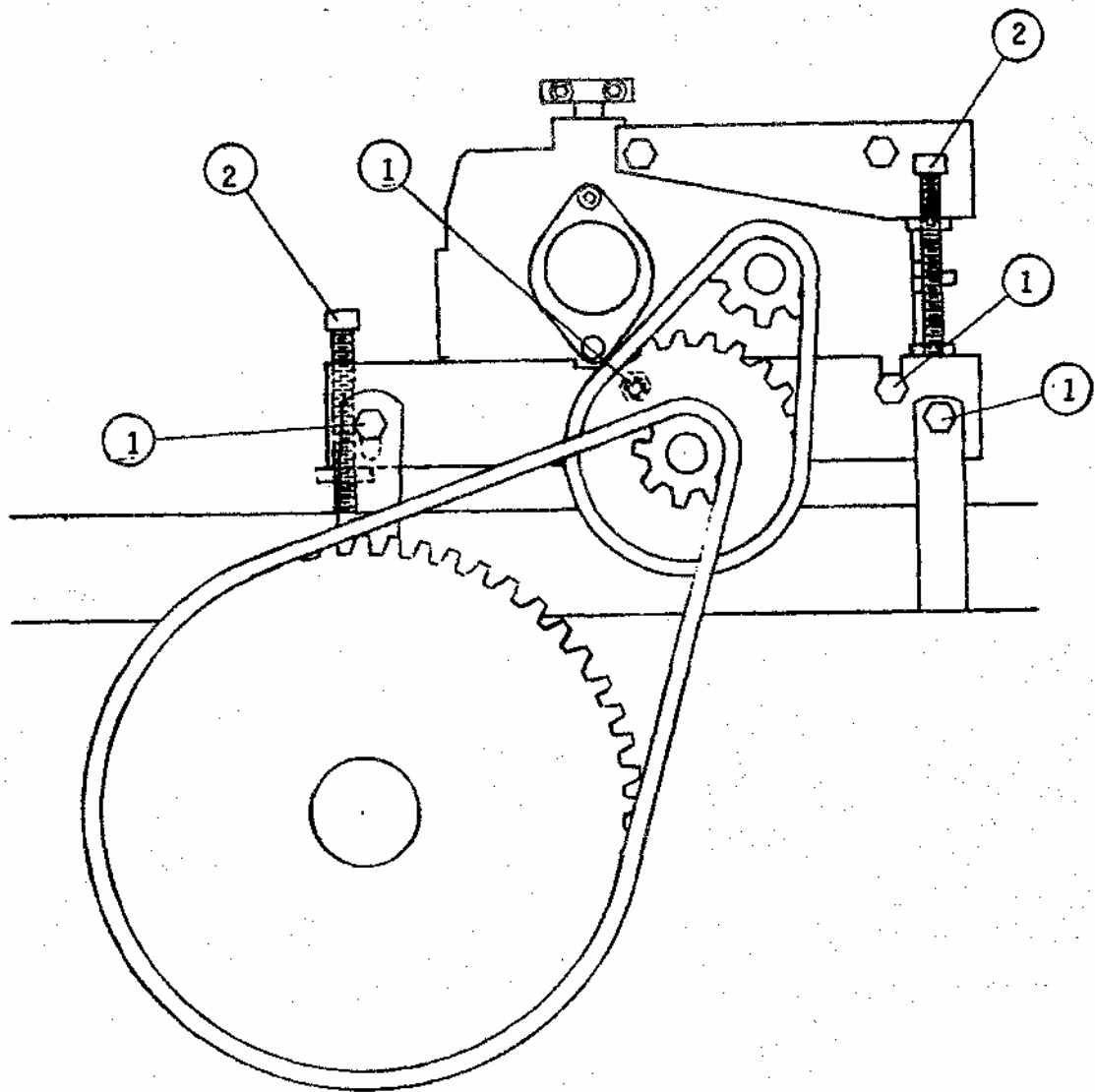

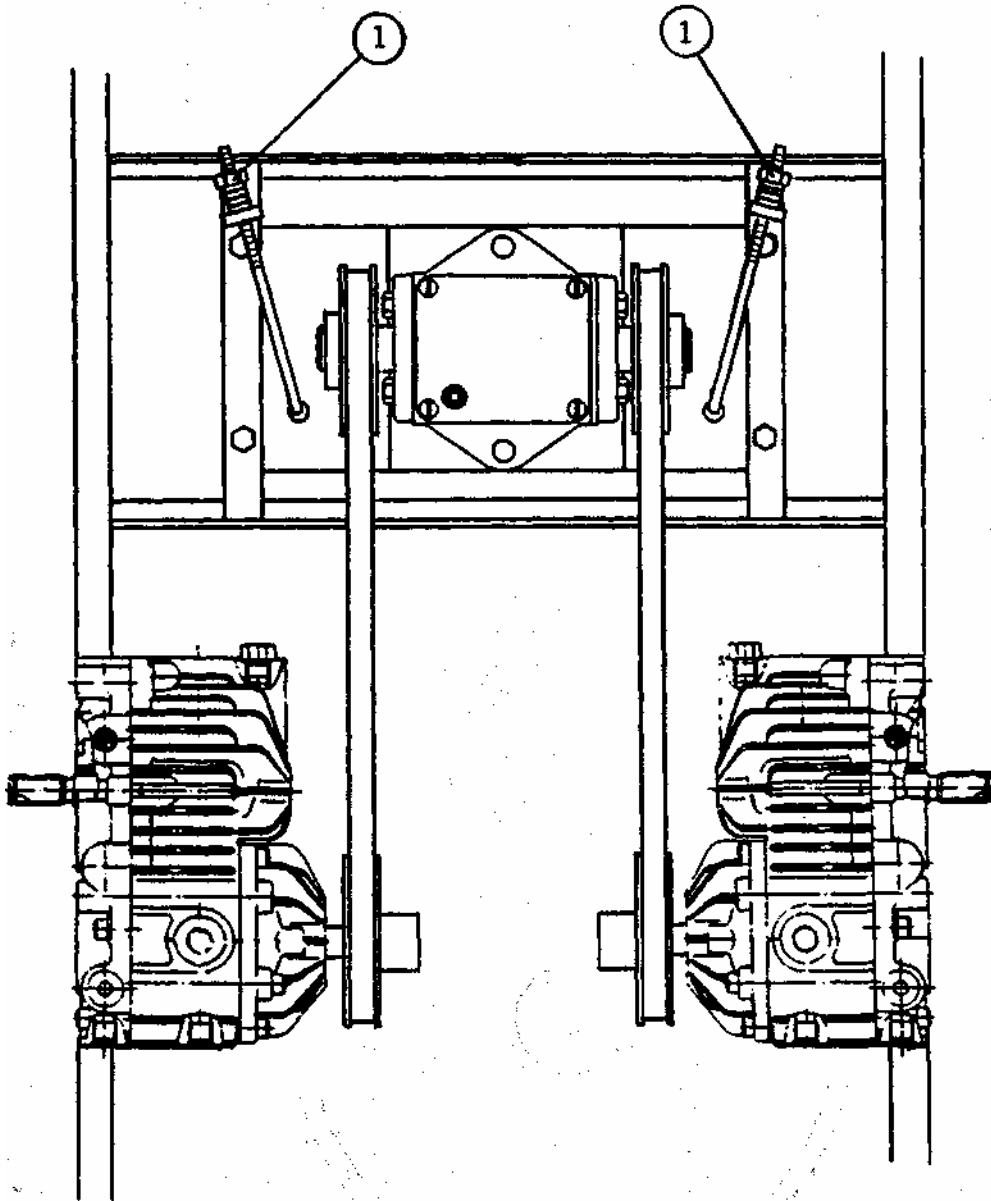

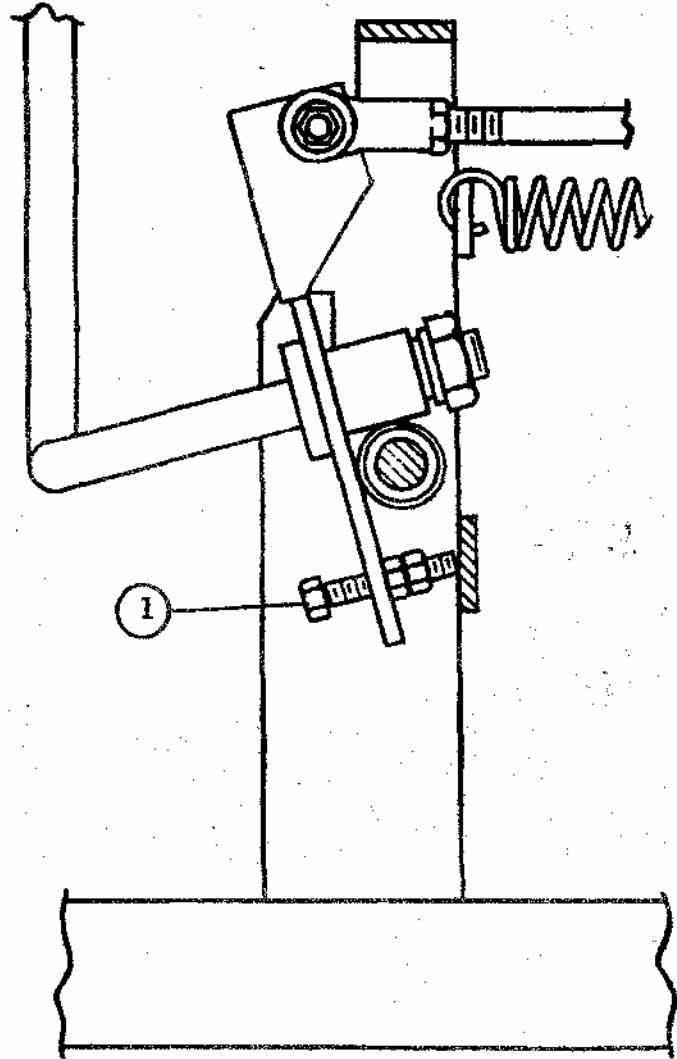

LUBRICATION:

CHASSIS AND MOWER DECK: Number of grease zerks used (3)
LOCATIONS: (1) each front wheel caster
SERVICE INTERVALS: Every (50) hours of operation
RECOMMENDED GREASE: Name brand wheel bearing or multi-purpose grease

CAUTION: The use of compressed air pressure greasing methods is not recommended as damage to seals and bearings could occur.

Using a hand pressure grease gun, lubricate each front caster to allow even distribution of grease within the caster, rotate or spin each front wheel caster after (3) pumps of the grease gun. Repeat process until the appearance of grease is noted completely around each caster.

DRIVE CHAINS: Primary and final drive
RECOMMENDED LUBRICANT: Name brand aerosol chain spray
SERVICE INTERVALS: As required for operating conditions

Remove excess dirt from chains, lubricate each chain completely by applying the lube to the inside of each connecting link. Applying lube directly to the top of the chain will only allow the lube to be thrown off in operation. The chains are of special construction which use o-rings to seal a factory lubricant inside of the chain. Additional lubrication will cushion chain to sprocket engagement. Avoid the use of any lubricants which may damage the o-rings used on this chain.

ENGINE OIL CHANGES: "Refer to separate owners manual furnished by the
OIL RECOMMENDATIONS: engine manufacturer."
SERVICE INTERVALS:

Please dispose of used oils at proper collection centers. Protect your environment.

CARE AND MAINTENANCE - MODEL 501

CLEANING THE MOWER:

A clean machine is a source of pride to the owner. However, cleaning by use of high pressure commercial washes is not recommended. The high water pressure, combined with solvents or alkaline detergents, can lead to corrosion of electrical components or damage to the sealed bearings used on your mower. A better approach is the use of mild household soaps and low water pressure. A stiff brush can be used to loosen excess grass and dirt build up. Avoid directing water pressure onto the mower deck hub assemblies, electrical wiring and engine components such as air filter openings. Never wash or clean the Sundstrand BDO 10 L hydrostatic transmissions, as damage to these units could result. To remove excess water which accumulates during washing of the mower either blow off with compressed air, if available, or start the engine, allowing a long enough operation time to dry thoroughly. It is advisable to engage the mower deck for a short time to disperse all water from pulleys and belts.

Please help protect the environment by avoiding all chemicals which may damage or cause harm to plants and animals in your area.

TROUBLE SHOOTING

MOWER CUT QUALITY:

There are many variables that can effect the cut quality of any multi blade mower. Type and condition of grass, ground speed, blade speed, and conditions are some of the variables that interact creating differences in cut quality results. In most cases, a smooth, even cut will be achieved without further adjustment.

The Trouble Shooting Chart suggests practices and adjustments that may be helpful in improving cut quality. Your Dixon ZTR Dealer is also available to provide assistance to you.

<u>SITUATION</u>	<u>CAUSES</u>	<u>REMEDY</u>
Poor cut quality	Ground speed	Reduce mowing speed
Poor cut quality	Loose belts	Adjust per operators manual
Poor cut quality	Engine RPM too low	Increase engine RPM to
Poor cut quality	Dull or bent blades	Sharpen or replace as required
Poor cut quality	Unlevel mower deck	Adjust per operators manual
Poor cut quality	Grass build-up under Mower deck	Clean out underside of mower deck
Poor cut quality	Improper blades	Replace with original equipment blades which are designed for the Model 501
Poor cut quality	Uneven tire pressures	Check and adjust as required per operators manual

DRIVE SYSTEM:

<u>SITUATION</u>	<u>CAUSES</u>	<u>REMEDY</u>
Mower pulls to one side or the other	Drive adjustment	Adjust per operators manual Consult your dealer for repair
Loss of drive power on one side or the other	T-Box belts slipping	Adjust per operators manual Consult your dealer for repair
Loss of power on both wheels after being operated for a length of time	Belt from engine to T-Box is slipping	Adjust per operators manual Consult your dealer for reoair
Poor driving performance	Operation of mower	Review operators section of owners manual
Oil leaks	Loose or missing hose clamps	Tighten or replace as required

TROUBLE SHOOTING

ELECTRICAL SYSTEM:

SITUATION	CAUSE	REMEDY
Starter will not turn engine over	Blown fuse	Inspect and replace fuse If fuse continues to burn consult your dealer for repair
Starter will not turn engine over	Dead battery	Charge battery
Battery discharge	Poor connections on battery Battery water low Wrong battery installed in mower	Tighten or replace as required
Battery discharge	Engine electrical system not functioning correctly	Have electrical system checked by your dealer
Battery discharge	Engine being operated at too low an RPM	Increase engine RPM Consult your dealer for information
Electric clutch will not engage mower deck blades	Low battery condition Poor connections on clutch switch Broken wiring	Repair or replace as required Consult your dealer for repair
Head lights do not operate	Poor connection, on lights Broken wiring Bad bulb	Repair or replace as required

Note:

Electrical system failures are generally simple in nature, always check the obvious first and then move onto the more complicated parts used. Poor battery service, loose connections, corrosion, frayed or broken wiring, are more likely than component failure.

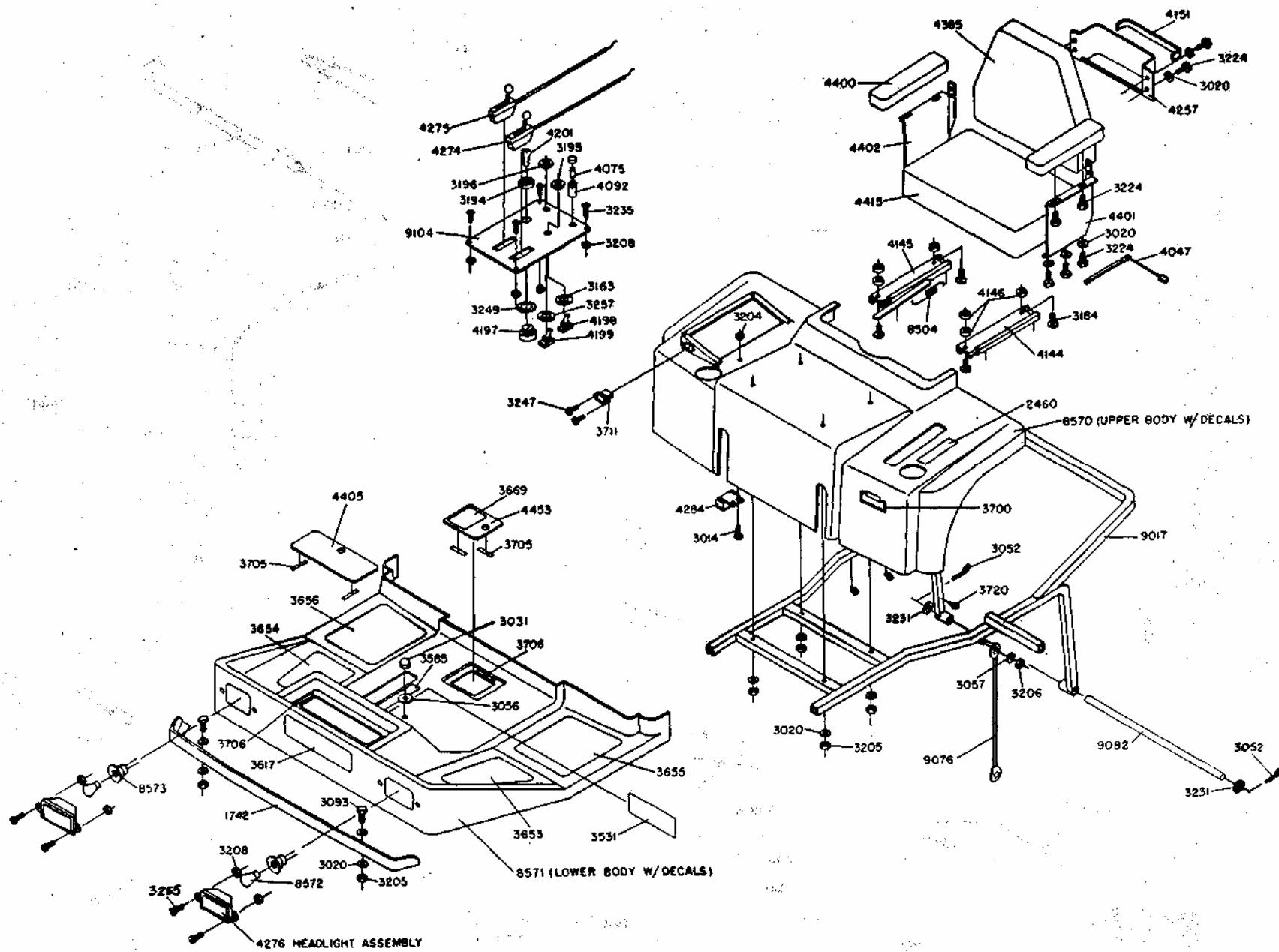

Illustration — Body Assembly (Model 501)

ZTR 501 - PARTS LIST

<u>PART#</u>	<u>DESCRIPTION</u>	<u>PART#</u>	<u>DESCRIPTION</u>
1657	Spring - Belt Idler	3180	1/4"-2Q Hex Locknut
1668	Drive Pulley	3182	Flip Lock Bushing
1675	Clutch Anchor	3184	5/16"-18 x 1 1/4" Pan Hd Phillips Screw
1682	L-Rod	3185	Washer
1701	Wheel/Deck Hub Bearing	3186	#12-24 x 3/4" Drill & Tap Screw
1702	Locking Collar	3187	#10-32 Hex Nut
1712	Battery Strap	3188	#10 Ext Tooth Lock Washer
1714	T-Box Drive Belt	3193	Washer .43 x 1.38 x .25
1715	Rear Wheel & Tire	3194	Face Nut 5/8"-32
1732	Pulley - T-Box	3195	Face Nut 1/2"-27
1733	Pulley - T-Box Drive	3196	Face Nut 7/16"-28
1734	Pulley Hydrostat	3198	1/4"-20 Wing Nut w/Nylok
1739	Hydrostat Idler Bracket	3204	1/4"-20 Hex Nut w/Nylok
1742	Bumper	3205	5/16"-18 Hex Nut w/Nylok
1743	Hydrostat Flat Idler Pulley HO	3206	3/8"-16 Hex Nut w/Nylok
1744	Hydrostat Drive Belt	3208	#10-24 Hex Nut w/Nylok
1745	Pulley	3220	7/16"-20 x 2 3/4" HH Bolt Gr 5
2128	Sleeve	3224	5/8"-18 x 3/4" HH Bolt w/Nylok Gr 5
2414	Spring	3225	3/8"-16 x 2 1/4" HH Bolt
2460	Parking Brake Decal	3228	5/8"-11 x 6 1/4" Carriage Bolt
2823	Oil Drain Assembly	3229	Washer
3005	5/16"-18 UNC Hex Nut	3231	9/16" Std Flatwasher
3006	5/16"-18 x 1 1/4" HH Bolt Gr 5	3233	Battery Hold Down Bolt
3007	1/4"-20 UNC Hex Nut	3235	#10-24 x 5/8" Phillips Pan Hd Screw
3008	1/4" ID x 3/4" 00 Flat Washer	3243	5/16"-18 x 3 1/4" HH Bolt Gr 5
3009	5/16"-18 UNC x 1 3/4" HH Bolt Gr 5	3245	3/8"-16 Thin Profile Nylok Nut
3014	1/4"-20 UNC x 3/4" HH Bolt Gr 5	3247	#6-20 x 1/2" Phillips Pan Hd Screw
3019	5/16" Helical Lock Washer	3248	5/16" ID x 1/8" Thick Washer
3020	5/16" Std Flat Washer	3249	5/8" Int Tooth Lock Washer
3023	1/4" Helical Lock Washer	3256	Snap Ring
3029	Front Grommet	3257	7/16" Int Tooth Lock Washer
3031	5/16"-18 UNC Acorn Nut	3258	5/16"-18 x 4 1/2" HH Bolt Gr 8
3033	1/2" SAE Flat Washer	3259	5/16"-18 x 5" HH Bolt Gr 8
3035	1/2"-13 UNC Hex Jam Lock Nut	3260	1/4"-20 x 1/2" HH Bolt Gr 5
3037	3/8"-24 UNF x 1 1/4" HH Bolt Gr 5	3262	3/4"-10 Thin Profile Nylok Nut
3047	3/8"-24 UNF Hex Lock Nut	3263	5/8"-11 Thin Profile Nylok Nut
3048	3/8"-16 UNC x 1 1/2" HH Bolt	3264	5/16" Disc Spring HD
3052	3/32" Dia x 1" Cotter P1n	3265	#10-24 x 3/4" Truss Hd Phillips Screw
3054	3/16" Dia x 1" Roll P1n	3266	1/4" Int Tooth Lockwasher (Not Shown)
3056	5/16" Fender Washer	3267	5/16"-18 x 1 3/8" HH Bolt Gr 5
3057	3/8" Std Flat Washer	3268	3/8"-24 x 1 1/4" HH Bolt Gr 8 w/Nylok
3061	5/16"-18 UNC 1 3/4" Soc Set Screw	3269	5/16"-18 x 1" Soc HB
3065	3/8" Helical Lock Washer	3270	5/16"-18 x 3" Soc HB
3066	3/16" Std Flat Washer	3271	1"-14 Thin Profile Nylok Nut
3072	1/8" x 1 3/4" Hatr Pin Cotter	3300	Foam Pad
3074	5/16"-24 UNF Hex Jam Nut	3511	Adhesive Bumper Pad
3081	16-32 UNC Hex Nut	3521	Engaging Cam Mount Bushing
3082	16 Lock Washer	3531	Decal - OPERATING INSTRUCTIONS
3087	5/16"-18 UNC x 3/4" HH Bolt Sr S	3S36	Decal - DANGER
3088	1/4"-20 x 1" HH Bolt Gr 5	3552	Tank Mount Bracket - Long
3090	1/4"-20 x 1 1/4" HH Bolt Gr 5	3553	Tank Mount Bracket - Short
3091	1/4"-20 UNF Hex Lug Nut	3554	Fuel Cap/Guage
3093	5/16"-18 UNC x 1" HH Bolt Gr 5	3558.	2 Gal Tank w/Cap-Gauge
3101	7/16" Helical Lock Washer	3578	Nylon Bushing
3106	1/4" x 1" Spirol P1n	3585	Decal - CUTTING HEIGHT
3107	1/4" x 1 1/2" Spiral Pin	3589	Spacer (Electric Clutch)
3118	Disc Spring	3590	Key 1/4" Sq x 1/2"
3133	#8-32 x 1 1/2" TR 3 Screw	3599	Iso Mount Assembly
3134	1/4"-28 x 1/4" Soc Set Screw	3600	Rebound Mount
3145	#6 Std Flat Washer	3601	Load Mount
3151	16-32 UNC x 1/2" Rd Hd Screw	3602	Spacer Tube
3161	5/16"-24 UNF LH Thread	3603	Iso Mount Insert
3163	1/2" Int Tooth Lock Washer	3617	Decal - DIXON
3169	3/8"-16 x 1" HH Bolt Gr 5	3635	Tee-Fuel Line
3174	1/2"-13 x 1" HH Bolt	3644	Fuel Line 7 1/2"

ZTR 501 - PARTS LIST

<u>PART#</u>	<u>DESCRIPTION</u>	<u>PART#</u>	<u>DESCRIPTION</u>
3645	Fuel Line 18"	5070	Key 3/16" Sq x 7/8"
3646	Fuel Line 20"	5085	Brake Band
3649	Fuel Line Clamp	5087	Spacer 3/8" x 1/2"
3653	Floor Pad Left Front	5101	Brake Link
3654	Floor Pad Right Front	5112	Key-Sq 3/16" x 1 1/2" (Fits 5110)
3655	Floor Pad Left Rear	5170	Spring
3656	Floor Pad Right Rear	5189	Bushing
3669	Decal - CAUTION	5500	T-Box
3695	J-Bolt	5501	Mount Plate
3700	Model Decal - (501)	5502	Mount Shim
3702	Pulley	5503	T-Box Guide Left
3705	Velcro Strip - Hook	5504	T-Box Guide Right
3706	Velcro Strip - Latch	5507	Brake Plate Bracket Left
3710	Handle Grip	5508	Brake Plate Bracket Right
3711	Hour Meter	5510	Sprocket 10T
3712	Handle Grip	5511	Sprocket 30T
3713	Foam Tube	5512	Sprocket 10 T w/Brake Drum
3714	End Cap	5514	Brake Rod 5/16" x 2 5/8"
3715	End Cap	5515	Idler Cable
3716	1/4" Hose Clamp	5516	Swivel
3717	3/8" Hose Clamp	5519	Brake Arm Left
3718	5/8" Hose Clamp	5521	Brake Arm Right
3719	Heat Shield Deflector	5522	Brake Link Right
3720	"Tie Wrap	5525	Brake Link Left
3721	Decal - DANGER	5530	Control Pivot Shaft
3722	Fibre Washer	5531	Adjustable Collar
3723	Decal - RESERVOIR	5537	Control Arm Bracket
4013	Wire Tie	5539	Hydrostat Support Rod
4075	10 Amp Fuse	5540	Neutral Adjust Collar
4092	Fuse Holder	5544	Swivel Bracket Control Lever Left
4124	Solenoid w/Hardware	5545	Swivel Bracket Control Lever Right
4144	Seat Slide w/o Adjuster	5546	Control Rod End Left
4145	Seat Slide w/Adjuster	5547	Control Rod End Right
4146	Nylon Washer	5549	Brake Handle
4151	Utility Box Trim	5550	Hydrostat Left
4197	Ignition Switch	5551	Hydrostat Right
4198	Blade Drive Clutch Switch	5553	Spacer 1/2" OD x 2 1/2"
4199	Light Switch	5554	Spacer 1/2" OD x 1/4"
4201	Switch Key (Used w/4197)	5555	Fan Left
4211	Solenoid Starter Cable	5556	Fan Right
4216	Battery Ground Cable	5558	Hose Fitting
4217	Battery	5559	Hose Fitting
4242	Deck Switch	556C	Fibow - Male
4257	Utility Box	5561	Adapter - Male (For 3/8" ID Hose)
4268	Upper Wiring Loom	5562	Adapter - Male (For 5/8" ID Hose)
4269	Lower Wiring Loom	5563	Tee - Cast Iron
4274	Choke Cable	5564	Filter Head
4275	Throttle Cable	5565	Oil Filter
4276	Headlight Assembly	5566	Hose 3/8" x 7"
4284	Relay	5567	Hose 3/8" x 13"
4331	Battery Cable	5568	Chain - Primary - Short
4385	Seat Back	5575	Shaft 3/4" x 8 1/4"
4400	Arm Rest Offset	5576	Spacer
4401	Arm Rest Bracket Left	5577	Drive Chain - Secondary
4402	Arm Rest Bracket Right	5579	Electric Clutch HO
4403	Arm Rest Assembly Left	5580	Jack Shaft Bracket Left
4404	Arm Rest Assembly Right	5581	Jack Shaft Bracket Right
4405	Battery Cover w/Velcro	5582	Pivot Shaft Bracket
4415	Seat Bottom	5583	Hose 5/8" x 19"
4428	Ground Wire (Hour Meter)	5584	Hose 1/4" x 14"
4430	Cover - Flex Guard	5585	Tab
4446	Cover - Flex Guard	5591	Reservoir Assembly
4448	Engine Wire Assembly	5592	Control Lever w/Gr1p Left Hand
4453	Access Cover Assembly	5593	Control Lever w/Grip Right Hand
5028	Bearing	5594	Tube

<u>PART#</u>	<u>DESCRIPTION</u>
5595	Hose 5/8" x 14"
6011	Mower Deck Bearing
6059	Flat Idler
6100	Outer Shaft Key
6101	Center Shaft Key
6111	Deck Drive Belt
6113	Blade Washer
8504	Seat Slide Spring
8570	Upper Body w/Decals
8571	Lower Body w/Decals
8572	Headlight Bulb
8573	Headlight Bulb Socket
8575	Wheel Hub Assembly
8576	Rear Rim
8577	Rear Tire
8580	Caster Wheel
8581	Caster Tire
8585	Wiring Kit
8602	Hardware Kit (Electric Clutch)
8645	Seat Assembly (501)
8648	Chain Connecting Link
8649	Rotor/Armature Assembly
8650	Clutch Field Assembly
8645	Cap For Reservoir
9002	Frame
9017	Seat Frame
9020	Caster
9022	Caster Axle Bushing
9023	Engine Mount Plate - Fwd
9024	Engine Mount Plate - Rear
9031	Spacer
9035	Lift Frame
9049	Lift Bushing Bracket
9055	Lift Cam Left
9056	Lift Cam Right
9057	Lift Rod
9065	Lift Handle
9066	Lift Shaft
9067	Control Rod
9076	Seat Frame Cable
9082	Seat Frame Pivot Rod
9088	Caster Wheel & Tire
9089	Control Rod Assembly
9098	L-Rod 9/16" x 15 3/16"
9104	Control Panel
9110	Tank Cover
9111	Rear Wheel Hub
9136	Tube
9200	Mower Deck Assembly
9201	Mower Deck Pan
9212	Spring (Belt Tensioner)
9219	Deck Hub
9224	Outer Shaft
9225	Center Shaft
9226	Deck Hub Sub Assembly
9228	Deck Hub Bearing Spacer
9229	Mower Blade
9230	Outer Hub Assembly
9231	Center Hub Assembly
9233	Deck Idler Bracket
9236	Serpentine Blade Drive Belt
9242	Pulley Guard
9245	Deflector
9254	Lift Plate

