



DIXON INDUSTRIES, INC. A  
BLOUNT COMPANY AIRPORT  
INDUSTRIAL PARK  
PO BOX 1569  
COFFEYVILLE KS 67337 0945  
3162512000  
FAX 316 251 4117

**BLOUNT**

## TECHNICAL DATA BROCHURE

### ZTR Model 3361

**IMPORTANT - READ OPERATOR'S MANUAL BEFORE OPERATING OR MAKING ADJUSTMENTS**

#### SEAT ADJUSTMENT

1. Pull or lift body retention latch P/N 3954 from transaxle backing plate, raise and push body and seat assembly forward.
2. Loosen four seat adjustment bolts P/N 3227 and slide seat forward or backward to desired position.
3. Re-tighten seat adjustment bolts P/N 3227. *DO NOT* operate mower without seat adjustment bolts properly tightened.
4. Close upper body and push re tention latch P/N 3954 over transaxle backing plate.

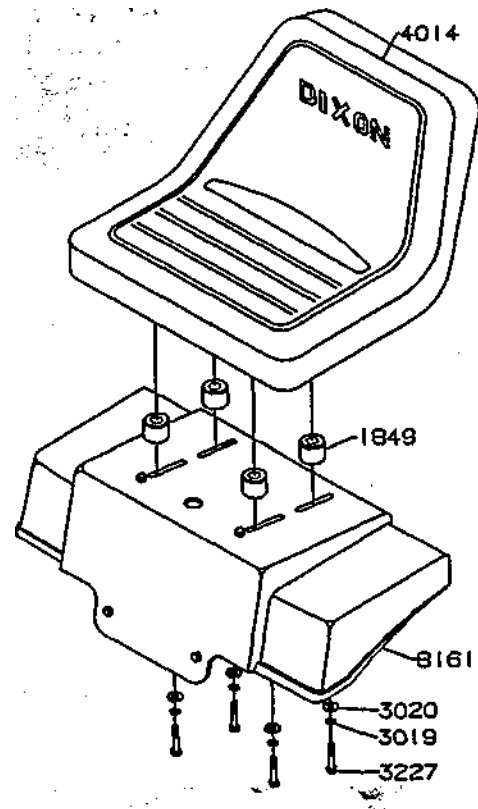

## **BODY REMOVAL**

1. The 3361 has a two-piece polyethylene body. The upper body can be folded forward to expose the transaxle. In some cases, it may be necessary to remove the upper body to service the transaxle.
2. To remove upper body, remove two bolts P/N 3093 from the front of upper body hinge located on the brake shaft P/N 9283. Disconnect seat switch P/N 4761 at plug-in.
3. Reverse above procedure to reinstall.

## **ADJUSTMENT OF MOWER DECK DRIVE BELT**

Belt tension is controlled and adjusted by tightening nut P/N 3205 on L -rod P/N 2841. Proper belt tension can be measured by pushing against belt at mid-point on the left side of the mower chassis. Belt should deflect approximately 3/4" to 1" when adjusted.

## **REMOVING MOWER BLADES**

1. Secure mower blade P/N 1324 from turning.
2. Observe blade position when removing.
3. Remove blade bolt P/N 3268, and blade washer P/N 6260.
4. To reinstall, reverse above procedure. Tighten to 50-60 ft pounds of torque.

**WARNING:** Sharp edges on blade can cause injury!  
Caution should be exercised when service is required on the blade.

## **REMOVING MOWER DECK**

1. Remove deck drive belt by loosening nylok nut P/N 3205 on L-Rod tensioner P/N 2841 until belt can be removed from electric clutch.
2. Remove the clevis pins P/N 3072 from L-rods at rear of deck and slide free from slots.
3. Remove the clevis pin P/N 3072 from the lift linkage at the front of deck.
4. Remove cotter pin from shaft P/N 1332 located at front of mower deck on slide plates welded at battery box. Slide shaft free.
5. Raise front of mower chassis and roll mower free of mower deck assembly.
6. To install deck, reverse above procedure.

## MOWER BLADE OPERATION

1. To start mower blades, pull up slightly on blade drive switch handle and move it forward to the "ON" position.
2. To stop mower blades, move switch handle to the "OFF" position

## SAFETY CHECKS

**IMPORTANT - PERFORM SAFETY CHECKS AFTER MAKING ANY REPAIRS OR ADJUSTMENTS**

1. After reassembly, while seated on mower, attempt to start engine with mower deck engaged. Engine should start. If engine does not start, return the mower to an Authorized Dixon dealer for adjustment or repair.
2. Disengage mower deck and start engine. With the operator in the normal seated position, engage mower deck and remove weight from seat. The engine should stop. If the engine does NOT stop when operator rises from seat, return the mower to an Authorized Dixon dealer for adjustment or repair.
3. Engage. Then disengage mower blade in each cutting height. Insure that blade disengages and comes to a stop within (5) seconds in each height position. If blade does NOT disengage properly, contact your Authorized Dixon dealer.

**CAUTION: DO NOT OPERATE MOWER IF ANY SAFETY FEATURE IS NOT FUNCTIONING CORRECTLY**

## PARKING BRAKE ADJUSTMENT

Tighten nut on brake rod P/N 2533, located in front of the transaxle on each side, just enough to prevent brake from slipping when engaged.

**CAUTION:** Over tightening may cause premature wear on the brake band P/N 5085.

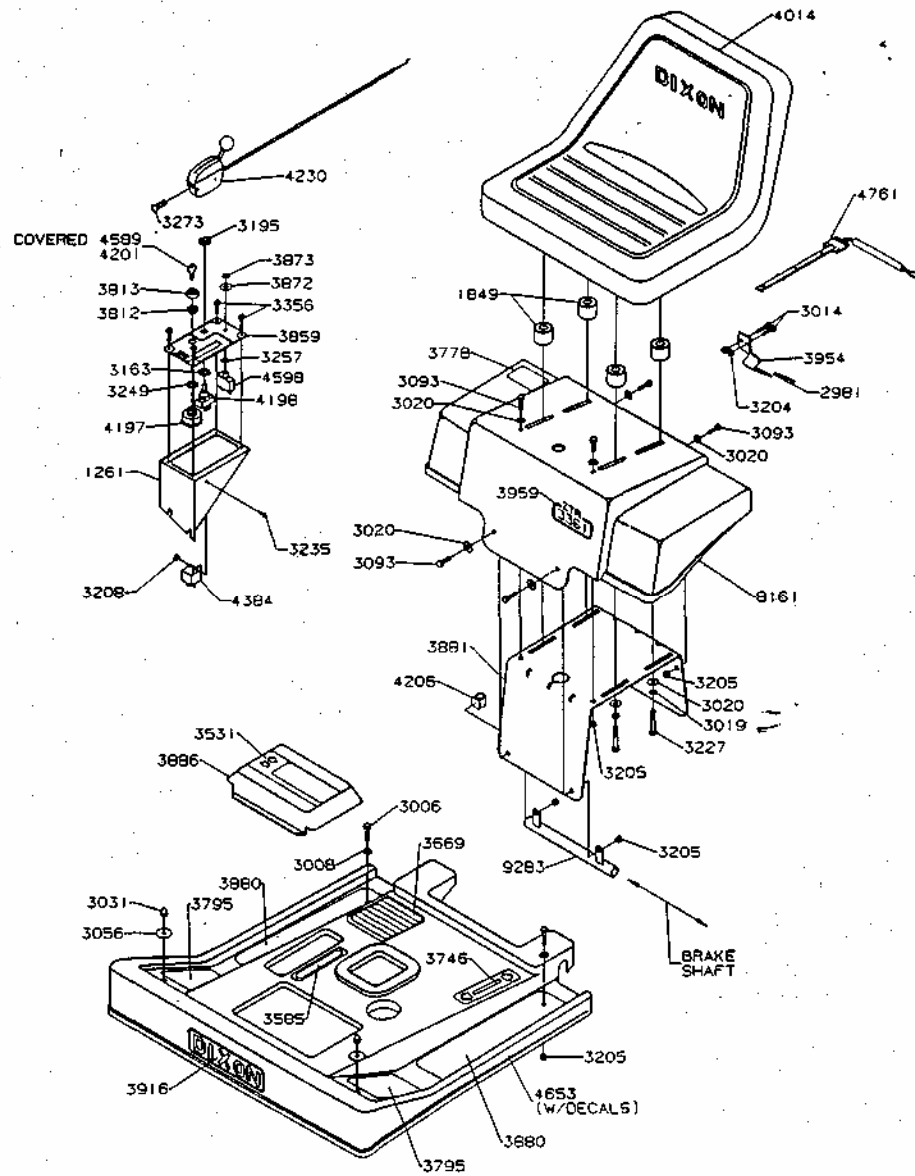

3361 BODY ASSEMBLY

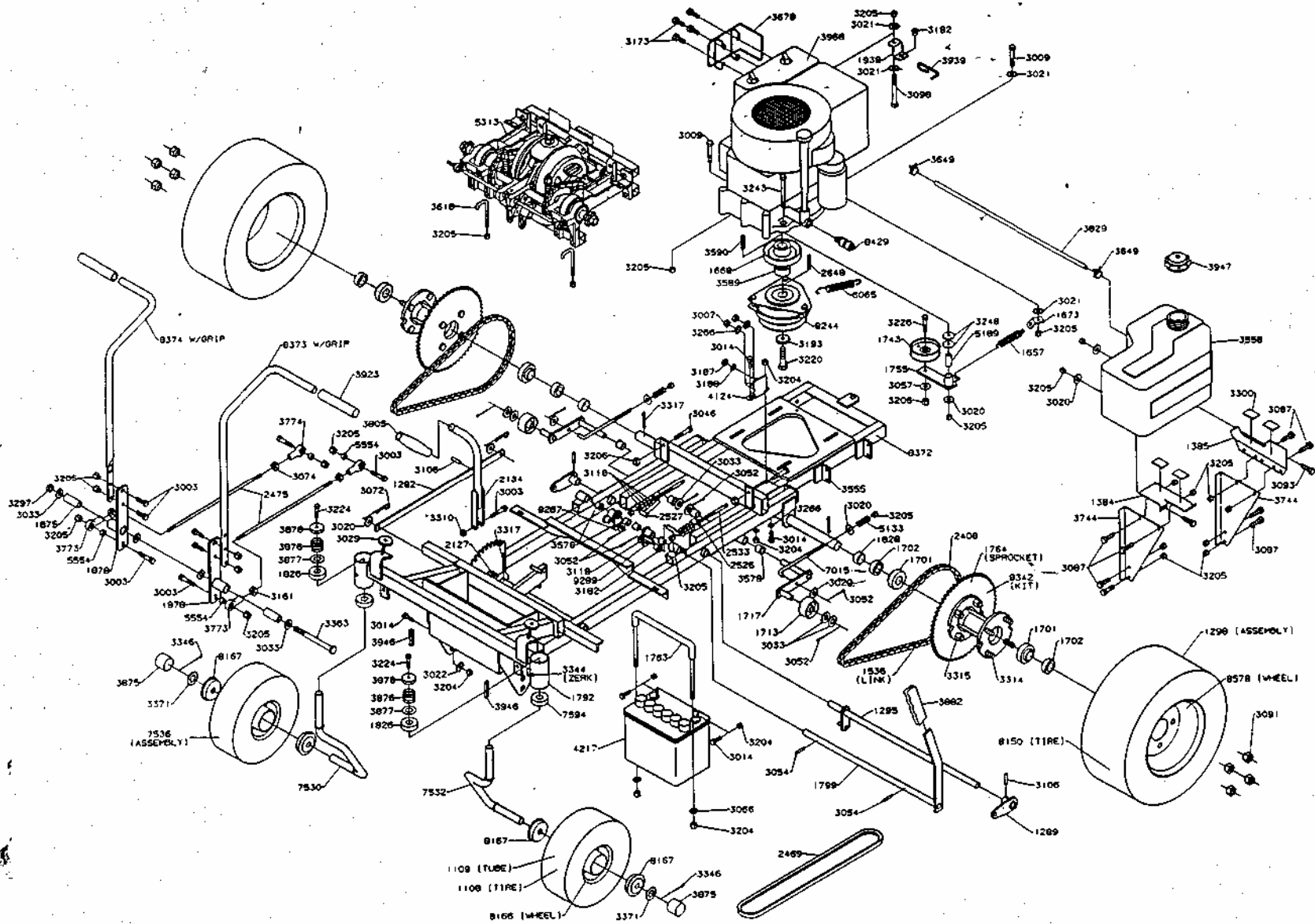





BODY WIRING LOOM 4763  
WIRING KIT 8370

