

Cub Cadet[®]

OPERATOR'S MANUAL

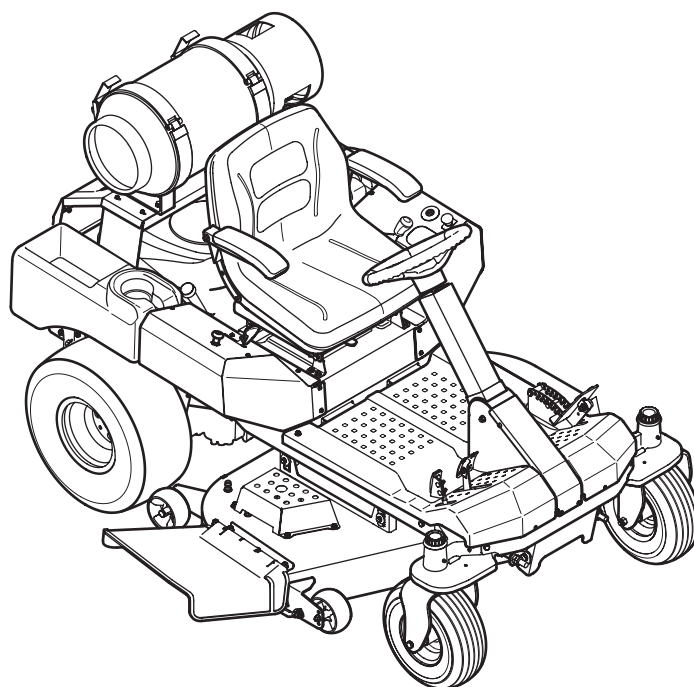

Z-Force S 48 Liquid Propane Gas

⚠ WARNING

**READ AND FOLLOW ALL SAFETY RULES AND INSTRUCTIONS IN THIS MANUAL
BEFORE ATTEMPTING TO OPERATE THIS MACHINE.
FAILURE TO COMPLY WITH THESE INSTRUCTIONS MAY RESULT IN PERSONAL INJURY.**

CUB CADET LLC, P.O. BOX 361131 CLEVELAND, OHIO 44136-0019

Thank You

Thank you for purchasing a Cub Cadet Zero-Turn Tractor. It was carefully engineered to provide excellent performance when properly operated and maintained.

Please read this entire manual prior to operating the equipment. It instructs you how to safely and easily set up, operate and maintain your machine. Please be sure that you, and any other persons who will operate the machine, carefully follow the recommended safety practices at all times. Failure to do so could result in personal injury or property damage.

All information in this manual is relative to the most recent product information available at the time of printing. Review this manual frequently to familiarize yourself with the machine, its features and operation. Please be aware that this Operator's Manual may cover a range of product specifications for various models. Characteristics and features discussed and/or illustrated in this manual may not be applicable to all models. We reserve the right to change product specifications, designs and equipment without notice and without incurring obligation.

If you have any problems or questions concerning the machine, phone your local Cub Cadet dealer or contact us directly. Cub Cadet's Customer Support telephone numbers, website address and mailing address can be found on this page. We want to ensure your complete satisfaction at all times.

Throughout this manual, all references to *right* and *left* side of the machine are observed from the operating position.

Table of Contents

Safe Operation Practices	3	Service	25
Assembly & Set-Up	9	Troubleshooting	30
Controls & Features.....	12	Replacement Parts	31
Operation.....	15	Attachments & Accessories	33
Maintenance & Adjustment.....	19	Warranties	34

Record Product Information

Before setting up and operating your new equipment, please locate the model plate on the equipment and record the information in the provided area to the right. You can locate the model plate by standing at the left side of the tractor, pivoting the seat forward and looking down at the seat frame. This information will be necessary, should you seek technical support via our web site or with your local Cub Cadet dealer.

MODEL NUMBER

--	--	--	--	--	--	--	--	--	--	--	--

SERIAL NUMBER

--	--	--	--	--	--	--	--	--	--	--	--

Customer Support

If you have difficulty assembling this product or have any questions regarding the controls, operation, or maintenance of this machine, you can seek help from the experts. Choose from the options below:

- ◇ Visit us on the web at www.cubcadet.com
- ◇ Locate your nearest Cub Cadet Dealer at (877) 282-8684
- ◇ Write us at Cub Cadet LLC • P.O. Box 361131 • Cleveland, OH • 44136-0019



WARNING! This symbol points out important safety instructions which, if not followed, could endanger the personal safety and/or property of yourself and others. Read and follow all instructions in this manual before attempting to operate this machine. Failure to comply with these instructions may result in personal injury.

When you see this symbol. **HEED ITS WARNING!**

CALIFORNIA PROPOSITION 65



WARNING! Engine Exhaust, some of its constituents, and certain vehicle components contain or emit chemicals known to State of California to cause cancer and birth defects or other reproductive harm.



WARNING! Battery posts, terminals, and related accessories contain lead and lead compounds, chemicals known to the State of California to cause cancer and reproductive harm. *Wash hands after handling*



DANGER! This machine was built to be operated according to the safe operation practices in this manual. As with any type of power equipment, carelessness or error on the part of the operator can result in serious injury. This machine is capable of amputating hands and feet and throwing objects. Failure to observe the following safety instructions could result in serious injury or death.

General Operation

1. Read, understand, and follow all instructions on the machine and in the manual(s) before attempting to assemble and operate. Keep this manual in a safe place for future and regular reference and for ordering replacement parts.
2. Be familiar with all controls and their proper operation. Know how to stop the machine and disengage them quickly.
3. Never allow children under 14 years of age to operate this machine. Children 14 and over should read and understand the instructions and safe operation practices in this manual and on the machine and should be trained and supervised by an adult.
4. Never allow adults to operate this machine without proper instruction.
5. To help avoid blade contact or a thrown object injury, keep bystanders, helpers, children and pets at least 75 feet from the machine while it is in operation. Stop machine if anyone enters the area.
6. Thoroughly inspect the area where the equipment is to be used. Remove all stones, sticks, wire, bones, toys, and other foreign objects which could be picked up and thrown by the blade(s). Thrown objects can cause serious personal injury.
7. Plan your mowing pattern to avoid discharge of material toward roads, sidewalks, bystanders and the like. Also, avoid discharging material against a wall or obstruction which may cause discharged material to ricochet back toward the operator.
8. Always wear safety glasses or safety goggles during operation and while performing an adjustment or repair to protect your eyes. Thrown objects which ricochet can cause serious injury to the eyes.
9. Wear sturdy, rough-soled work shoes and close-fitting slacks and shirts. Loose fitting clothes and jewelry can be caught in movable parts. Never operate this machine in bare feet or sandals.
10. Be aware of the mower and attachment discharge direction and do not point it at anyone. Do not operate the mower without the discharge cover or entire grass catcher in its proper place.
11. Do not put hands or feet near rotating parts or under the cutting deck. Contact with the blade(s) can amputate hands and feet.
12. A missing or damaged discharge cover can cause blade contact or thrown object injuries.
13. Stop the blade(s) when crossing gravel drives, walks, or roads and while not cutting grass.

14. Watch for traffic when operating near or crossing roadways. This machine is not intended for use on any public roadway.
15. Do not operate the machine while under the influence of alcohol or drugs.
16. Mow only in daylight or good artificial light.
17. Never carry passengers.
18. Back up slowly. Always look down and behind before and while backing to avoid a back-over accident. Be aware and pay attention to the safety system function that stops power to the blades when driving in reverse. If not functioning properly, contact an authorized dealer for safety system inspection and repair.
19. Slow down before turning. Operate the machine smoothly. Avoid erratic operation and excessive speed.
20. Disengage blade(s), set parking brake, stop engine and wait until the blade(s) come to a complete stop before removing grass catcher, emptying grass, unclogging chute, removing any grass or debris, or making any adjustments.
21. Never leave a running machine unattended. Always turn off blade(s), place drive control levers in neutral, set parking brake, stop engine and remove key before dismounting.
22. Use extra care when loading or unloading the machine into a trailer or truck. This machine should not be driven up or down ramp(s), because the machine could tip over, causing serious personal injury. The machine must be pushed manually on ramp(s) to load or unload properly.
23. Muffler and engine become hot and can cause a burn. Do not touch.
24. Check overhead clearances carefully before driving under low hanging tree branches, wires, door openings etc., where the operator may be struck or pulled from the machine, which could result in serious injury.
25. Disengage all attachment clutches, set the parking brake to the 'ON' position.
26. Your machine is designed to cut normal residential grass of a height no more than 10". Do not attempt to mow through unusually tall, dry grass (e.g., pasture) or piles of dry leaves. Dry grass or leaves may contact the engine exhaust and/or build up on the mower deck presenting a potential fire hazard.
27. Use only accessories and attachments approved for this machine by the machine manufacturer. Read, understand and follow all instructions provided with the approved accessory or attachment.
28. Data indicates that operators, age 60 years and above, are involved in a large percentage of riding mower-related injuries. These operators should evaluate their ability to operate the riding mower safely enough to protect themselves and others from serious injury.
29. If situations occur which are not covered in this manual, use care and good judgment. Contact your customer service representative for assistance.

Slope Operation

Slopes are a major factor related to loss of control and tip-over accidents which can result in severe injury or death. All slopes require extra caution. If you cannot back up the slope or if you feel uneasy on it, do not mow it.

For your safety, use the slope gauge included as part of this manual to measure slopes before operating this machine on a sloped or hilly area. If the slope is greater than 15 degrees as shown on the slope gauge, do not operate this machine on that area or serious injury could result.

Do:

1. Mow across slopes, not up and down. Exercise extreme caution when changing direction on slopes.
2. Watch for holes, ruts, bumps, rocks, or other hidden objects. Uneven terrain could overturn the machine. Tall grass can hide obstacles.
3. Use slow speed. Choose a low enough speed so that you will not have to stop while on the slope. Avoid starting or stopping on a slope. If the tires are unable to maintain traction, disengage the blades and proceed slowly and carefully straight down the slope.
4. Follow the manufacturer's recommendations for wheel weights or counterweights to improve stability.
5. Use extra care with grass catchers or other attachments. These can change the stability of the machine.
6. Keep all movement on the slopes slow and gradual. Do not make sudden changes in speed or direction. Rapid acceleration or deceleration could cause the front of the machine to lift and rapidly flip over backwards, which could cause serious injury.

Do Not:

1. Do not turn on slopes unless necessary; then turn slowly uphill and use extra care while turning.
2. Do not mow near drop-offs, ditches or embankments. The mower could suddenly turn over if a wheel is over the edge of a cliff, ditch, or if an edge caves in.
3. Do not try to stabilize the machine by putting your foot on the ground.
4. Do not use a grass catcher on steep slopes.
5. Do not mow on wet grass. Reduced traction could cause sliding.
6. Do not tow heavy pull behind attachments (e.g. loaded dump cart, lawn roller, etc.) on slopes greater than 5 degrees. When going down hill, the extra weight tends to push the tractor and may cause you to lose control (e.g. tractor may speed up, braking and steering ability are reduced, attachment may jack-knife and cause tractor to overturn).

Children

1. Tragic accidents can occur if the operator is not alert to the presence of children. Children are often attracted to the machine and the mowing activity. They do not understand the dangers. Never assume that children will remain where you last saw them.
 - a. Keep children out of the mowing area and in watchful care of a responsible adult other than the operator.
 - b. Be alert and turn machine off if a child enters the area.
 - c. To avoid back-over accidents, always look behind and down for small children.
 - d. Never carry children, even with the blade(s) shut off. They may fall off and be seriously injured or interfere with safe machine operation.
 - e. Use extreme care when approaching blind corners, doorways, shrubs, trees or other objects that may block your vision of a child who may run into the path of the machine.
 - f. Keep children away from hot or running engines. They can suffer burns from a hot muffler.
 - g. Remove key when machine is unattended to prevent unauthorized operation.
2. Never allow children under 14 years of age to operate this machine. Children 14 and over should read and understand the instructions and safe operation practices in this manual and on the machine and should be trained and supervised by an adult.

Towing

1. Tow only with a machine that has a hitch designed for towing. Do not attach towed equipment except at the hitch point.
2. Follow the manufacturer's recommendation for weight limits for towed equipment and towing on slopes.
3. Never allow children or others in or on towed equipment.
4. On slopes, the weight of the towed equipment may cause loss of traction and loss of control.
5. The maximum weight on the hitch is 50 lbs and the maximum towed load is 500 lbs.
6. Never allow passengers on the towed equipment.
7. Loss of traction can occur on slopes, 5° (9 %) maximum grade.
8. Travel slowly and allow extra distance to stop.
9. Use caution during turns to avoid jack-knifing.
10. Use extra caution when operating in reverse.
11. Do not modify or repair the hitch, replace the hitch if damaged.
12. Travel slowly and allow extra distance to stop.
13. Do not shift to neutral and coast downhill.

Service

Related to Fuel:



DANGER! Never have the mower near an open flame or spark, or allow smoking when refueling the system. Always handle LPG cylinders with care. LPG is a safe but highly flammable fuel.

1. Always handle LPG with care. LPG is a safe but highly flammable fuel. Please respect it.
2. LPG causes skin burns on contact. Avoid contact and wear appropriate clothing, gloves and eyewear.
3. If you smell or see gas, or hear the hiss of escaping gas, immediately get away from the cylinder and contact your local fire department.
4. Do not smoke or permit others to smoke while handling LPG.
5. Do not expose the cylinder to heat above 120°F.
6. Always close the valves on the cylinders when not in use.
7. Use only cylinders that meet code #49 of the federal regulation #173.34.
8. Use LPG classified HD-5 by National Gas Processors Association (NGPA).
9. Never attempt to remove an LPG cylinder while the mower is running.
10. Cylinders must be filled by trained personnel only.
11. Store cylinders in well ventilated and unoccupied buildings away from sparks and flames.
12. Always shut off the engine and permit it to cool before removing the fuel line and/or the LPG cylinder.
13. When removing and/or replacing fuel lines on the LPG tanks, make sure that the nozzles are free of any debris that might clog or damage the nozzle. Debris in the nozzle or damage to the nozzle may cause a failure of the check valve, which may compromise the seal and become a fire hazard.

General Service



DANGER! Never modify or tamper with the cylinder, hoses, check valves, shut-off valve, or regulator as this could result in poor system performance, leakage, and a fire hazard.

1. Never run an engine indoors or in a poorly ventilated area. Engine exhaust contains carbon monoxide, an odorless, and deadly gas.
2. Before cleaning, repairing, or inspecting, make certain the blade(s) and all moving parts have stopped. Disconnect the spark plug wires and remove the key from the ignition to prevent unintended starting.
3. Periodically check to make sure the blades come to complete stop within approximately (7) seven seconds after operating the blade disengagement control. If the blades do not stop within this time frame, your machine should be serviced.

4. Regularly check the safety interlock system for proper function, as described later in this manual. If the safety interlock system does not function properly, have your machine serviced.
5. Check the blade(s) and engine mounting bolts at frequent intervals for proper tightness. Also, visually inspect blade(s) for damage (e.g., excessive wear, bent, cracked). Replace the blade(s) with the original equipment manufacturer's (O.E.M.) blade(s) only, listed in this manual. "Use of parts which do not meet the original equipment specifications may lead to improper performance and compromise safety!"
6. Mower blades are sharp. Wrap the blade or wear gloves, and use extra caution when servicing them.
7. Keep all nuts, bolts, and screws tight to be sure the equipment is in safe working condition.
8. Never tamper with the safety interlock system or other safety devices. Check their proper operation regularly.
9. After striking a foreign object, stop the engine, disconnect the spark plug wire(s) and ground against the engine. Thoroughly inspect the machine for any damage. Repair the damage before starting and operating.
10. Never attempt to make adjustments or repairs to the machine while the engine is running.
11. Grass catcher components and the discharge cover are subject to wear and damage which could expose moving parts or allow objects to be thrown. For safety protection, frequently check components and replace immediately with original equipment manufacturer's (O.E.M.) parts only, listed in this manual. Use of parts which do not meet the original equipment specifications may lead to improper performance and compromise safety!
12. Do not change the engine governor settings or over-speed the engine. The governor controls the maximum safe operating speed of the engine.
13. Do not tamper with or adjust the regulator since the LPG system and the engine warranty will be voided and the exhaust emissions compromised — this could result damage to the engine and exhaust system with possible fines imposed by the EPA or CARB. The regulator is factory set to provide optimal performance in regard to power and emissions.
14. Maintain or replace safety and instruction labels, as necessary.
15. Observe proper disposal laws and regulations for gas, oil, etc. to protect the environment.

Do not modify engine

To avoid serious injury or death, do not modify engine in any way. Tampering with the governor setting can lead to a runaway engine and cause it to operate at unsafe speeds. Never tamper with factory setting of engine governor.

Notice Regarding Emissions

Engines which are certified to comply with California and federal EPA emission regulations for SORE (Small Off Road Equipment) are certified to operate on regular unleaded gasoline and LPG, and may include the following emission control systems: Engine Modification (EM) and Three Way Catalyst (TWC) if so equipped.

Spark Arrestor











WARNING! This machine is equipped with an internal combustion engine and should not be used on or near any unimproved forest-covered, brush-covered or grass-covered land unless the engine's exhaust system is equipped with a spark arrester meeting applicable local or state laws (if any).

If a spark arrester is used, it should be maintained in effective working order by the operator. In the State of California the above is required by law (Section 4442 of the California Public Resources Code). Other states may have similar laws. Federal laws apply on federal lands.

A spark arrester for the muffler is available through your nearest engine authorized service dealer or contact the service department, P.O. Box 361131 Cleveland, Ohio 44136-0019.

Safety Symbols

This page depicts and describes safety symbols that may appear on this product. Read, understand, and follow all instructions on the machine before attempting to assemble and operate.

Symbol	Description
	READ THE OPERATOR'S MANUAL(S) Read, understand, and follow all instructions in the manual(s) before attempting to assemble and operate
	WARNING — ROTATING BLADES Do not put hands or feet near rotating parts or under the cutting deck. Contact with the blade(s) can amputate hands and feet.
	WARNING — THROWN OBJECTS This machine may pick up and throw and objects which can cause serious personal injury.
	WARNING — THROWN OBJECTS This machine may pick up and throw and objects which can cause serious personal injury.
	BYSTANDERS Keep bystanders, helpers, children and pets at least 75 feet from the machine while it is in operation.
	WARNING — SLOPE OPERATION Do not operate this machine on a slope greater than 15 degrees.
	DANGER — ROTATING BLADES To reduce the risk of injury, keep hands and feet away. Do not operate unless discharge cover or grass catcher is in its proper place. If damaged, replace immediately.
	CAUTION/DANGER — OVERFILLING IS HAZARDOUS/FLAMMABLE GAS & LIQUID This cylinder is designed to contain a liquified petroleum gas under pressure that is highly flammable, operating & servicing of this cylinder must be conducted by persons properly trained & qualified in accordance with local, state, federal or provincial jurisdiction requirements.



WARNING! Your Responsibility — Restrict the use of this power machine to persons who read, understand and follow the warnings and instructions in this manual and on the machine.

SAVE THESE INSTRUCTIONS!

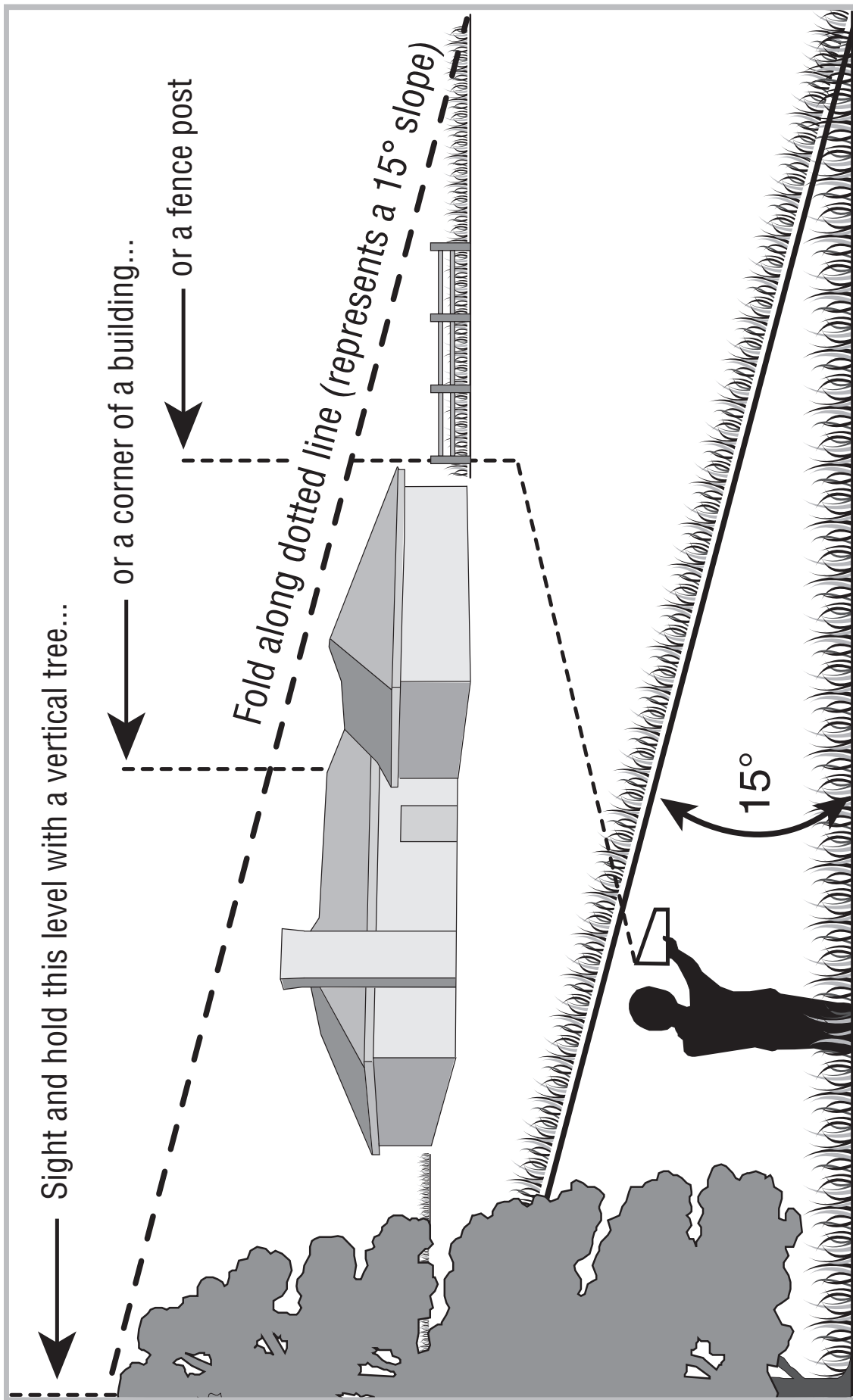

Use this page as a guide to determine slopes where you may not operate safely.



WARNING! Do not operate your lawn mower on such slopes. Do not mow on inclines with a slope in excess of 15 degrees (a rise of approximately 2-1/2 feet every 10 feet). A riding mower could overturn and cause serious injury.

OPERATE Z-Force-S zero turn tractors across the face of slopes rather than up and down. Begin with the first pass across the bottom of the slope and turn uphill at the end of each pass whenever possible.

Contents of Crate

- One Lawn Tractor
- One Oil Drain Hose
- One Deck Wash Hose Coupler
- One Z-Force S Tractor Operator's Manual
- One Engine Operator's Manual
- LPG Tank Strap Assemblies
- One Hardware Pack

Tractor Preparation

Unpacking the Tractor

1. Remove the upper crating material from the shipping pallet, and cut any bands or tie straps securing the tractor to the pallet.
2. If the deck is not in the highest mowing position (pushed all the way forward), use the deck lift pedal to raise the deck to its highest position. Refer to the Controls & Features section for instructions on raising and lowering the deck.
3. Disengage the parking brake.
4. Engage the transmission bypass rods on each side of the tractor; then carefully roll the tractor off the shipping pallet. The transmission bypass rods (one for each the RH and LH transmission) are located on the rear of the tractor, just inside each rear wheel. Disengage the bypass rods. See Fig. 3-1.

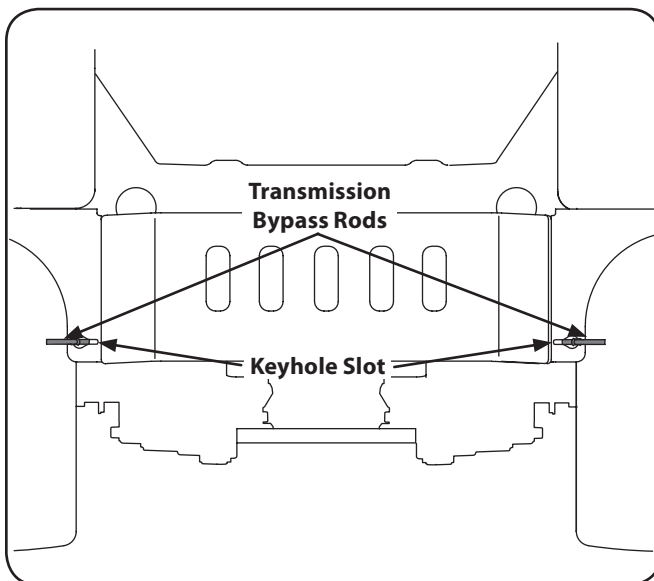

Figure 3-1

5. Remove the deck wash system nozzle adapter and oil drain tube from the manual bag and store for future use.

Initial LPG Tank Fill-Up

NOTE: The vapor withdrawal service valve of the Aluminum Outdoor Equipment Propane Cylinder is fitted with left-hand threaded safety coupler. Typical forklift cylinders withdraw liquid propane and have right-handed safety couplers. The different safety couplers prevent users from installing cylinders on the wrong equipment.

The LPG tank is shipped separately and will need to be purged before the initial fill-up.

It is important to properly purge new propane cylinders before the first fill. The authorized LP-Gas filler should follow proper purge guidelines outlined in NPGA Bulletin #133.89(a).

Once properly purged, fill the cylinder through the fill valve with Overfill Prevention Device (OPD) in accordance with section 7.4 of the Liquefied Petroleum Gas Code, NFPA 58-2008.

Installing the LPG Tank Straps

The tank straps need to be installed before the tank can be installed. To install the tank proceed as follows:

1. Remove the strap assemblies, alignment pin and two bolts from the box. Then remove the four hex screws and flange lock nuts from the manual bag.
2. Mount the alignment pin to the strap assembly using the two bolts. See Fig. 3-2. Then using the hex screws and flange lock nuts mount the strap assemblies to the mount plate as shown in Fig. 3-2.

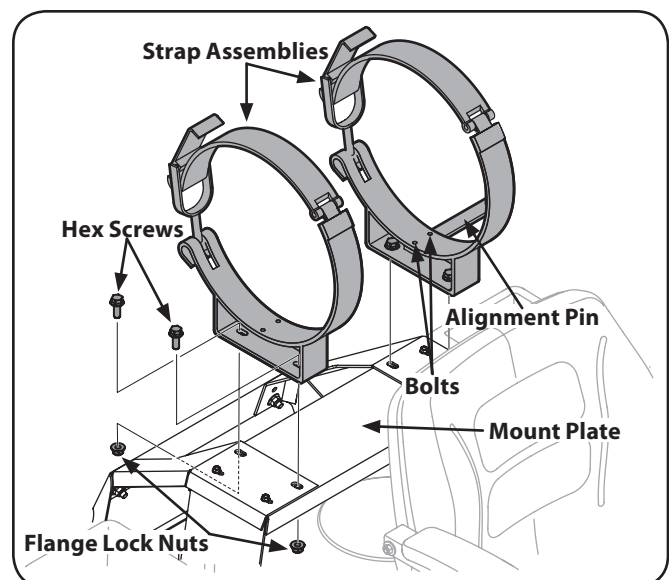

Figure 3-2

Installing the LPG Tank

1. Open the straps and carefully place the LPG tank into the straps with the cylinder valve guard towards the left. Be sure that the alignment pin fits into the slot on the bottom of the cylinder valve guard. See Fig. 3-3.

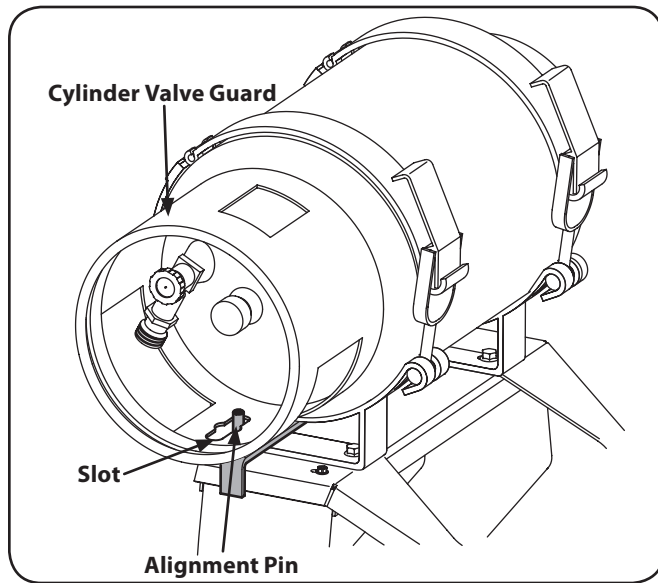

Figure 3-3

2. When the tank is in place, secure it by locking down the straps (A). See Fig. 3-4.

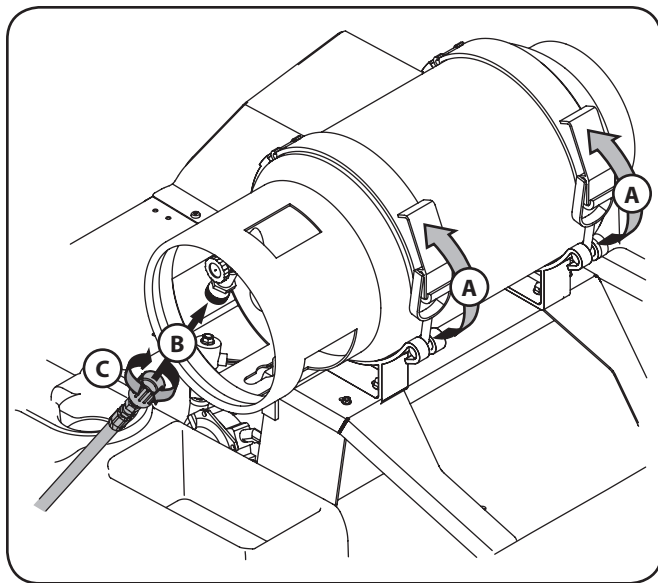

Figure 3-4

3. Install the regulator hose on the LPG tank fuel valve (B) and secure it by twisting it counter-clockwise (C). See Fig. 3-4.

NOTE: The hose has left-handed threads to prevent improper usage.

Steering Wheel Column

The steering wheel column is tilted all the way back for shipping purposes. To tilt the column forward, press the steering tilt pedal. Release the steering tilt pedal when the column is in the desired position.

Steering Wheel

1. Remove the hardware for attaching the steering wheel from beneath the steering wheel cap. Carefully pry off the steering wheel cover to remove the hardware.
2. With the wheels of the tractor pointing straight forward, place the steering wheel over the steering shaft.
3. Place the flat washer and belleville washer over the steering wheel and secure with the hex screw. See Fig. 3-5.

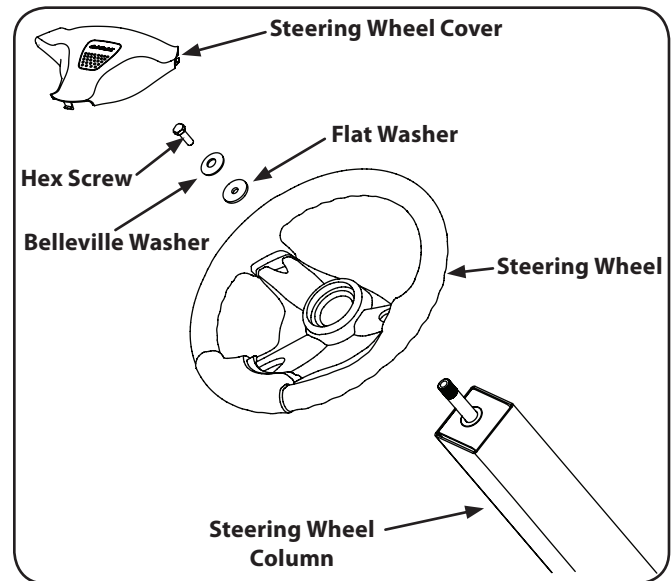

Figure 3-5

4. Place the steering wheel cover over the center of the steering wheel and push downward until it "clicks" into place.

Install Operator's Seat

To install the seat proceed as follows:

NOTE: The seat is shipped with the seat switch and seat pan attached. A second person may be needed to hold the seat.

1. Cut any straps securing the seat assembly to the tractor. Remove any packing material.

NOTE: Be careful not to cut the wiring harness connecting the seat and the seat switch in the bottom of the seat.

2. Remove the two shoulder bolts and lock nuts in the seat pan as shown in Fig. 3-6.

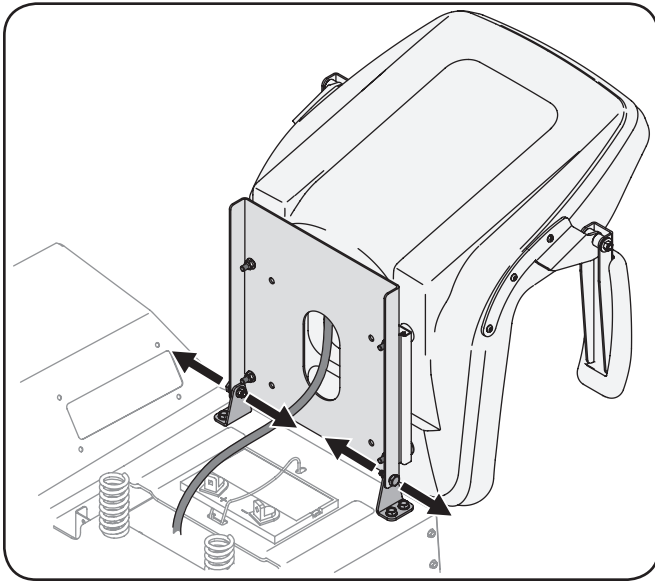

Figure 3-6

3. Rotate the seat into position and secure the seat into place with the previously removed shoulder bolts and lock nuts. Be careful not to crimp or damage the wire harness while installing the seat. See Fig. 3-7.

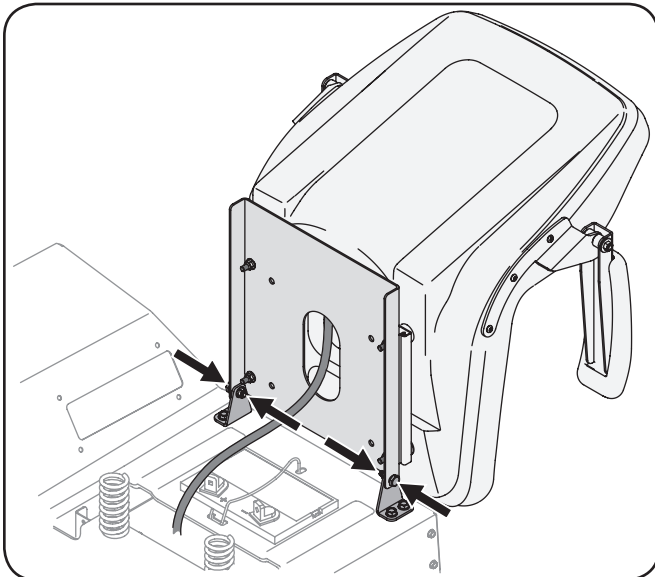

Figure 3-7

Connecting the Battery Cables



CALIFORNIA PROPOSITION 65 WARNING!

Battery posts, terminals, and related accessories contain lead and lead compounds, chemicals known to the State of California to cause cancer and reproductive harm. Wash hands after handling.



CAUTION: When attaching battery cables, always connect the POSITIVE (Red) wire to its terminal first, followed by the NEGATIVE (Black) wire.

For shipping reasons, both battery cables on your equipment may have been left disconnected from the terminals at the factory. To connect the battery cables, proceed as follows:

NOTE: The positive battery terminal is marked Pos. (+). The negative battery terminal is marked Neg. (-).

NOTE: If the positive battery cable is already attached, skip ahead to step 2.

1. Remove the plastic cover, if present, from the positive battery terminal and attach the red cable to the positive battery terminal (+) with the bolt and hex nut. See Fig. 3-8.

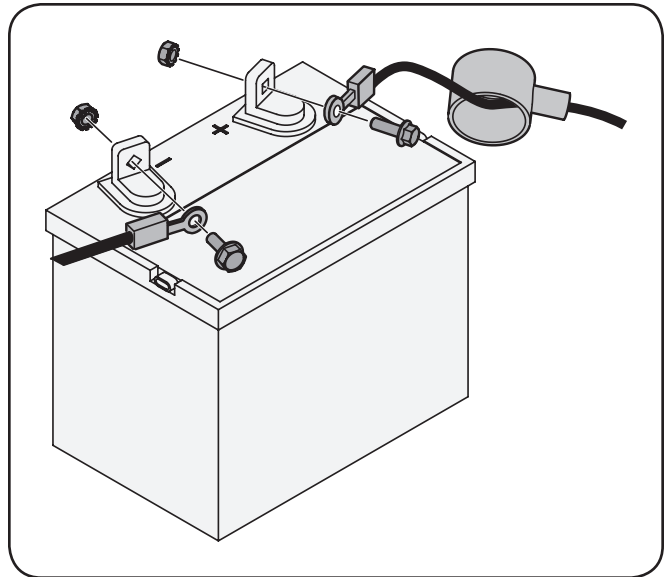

Figure 3-8

2. Remove the plastic cover, if present, from the negative battery terminal and attach the black cable to the negative battery terminal (-) with the bolt and hex nut. See Fig. 3-8.
3. Position the red rubber boot over the positive battery terminal to help protect it from corrosion.

NOTE: If the battery is put into service after the date shown on top/side of battery, charge the battery as instructed in the Maintenance section your Operator's Manual prior to operating the tractor.

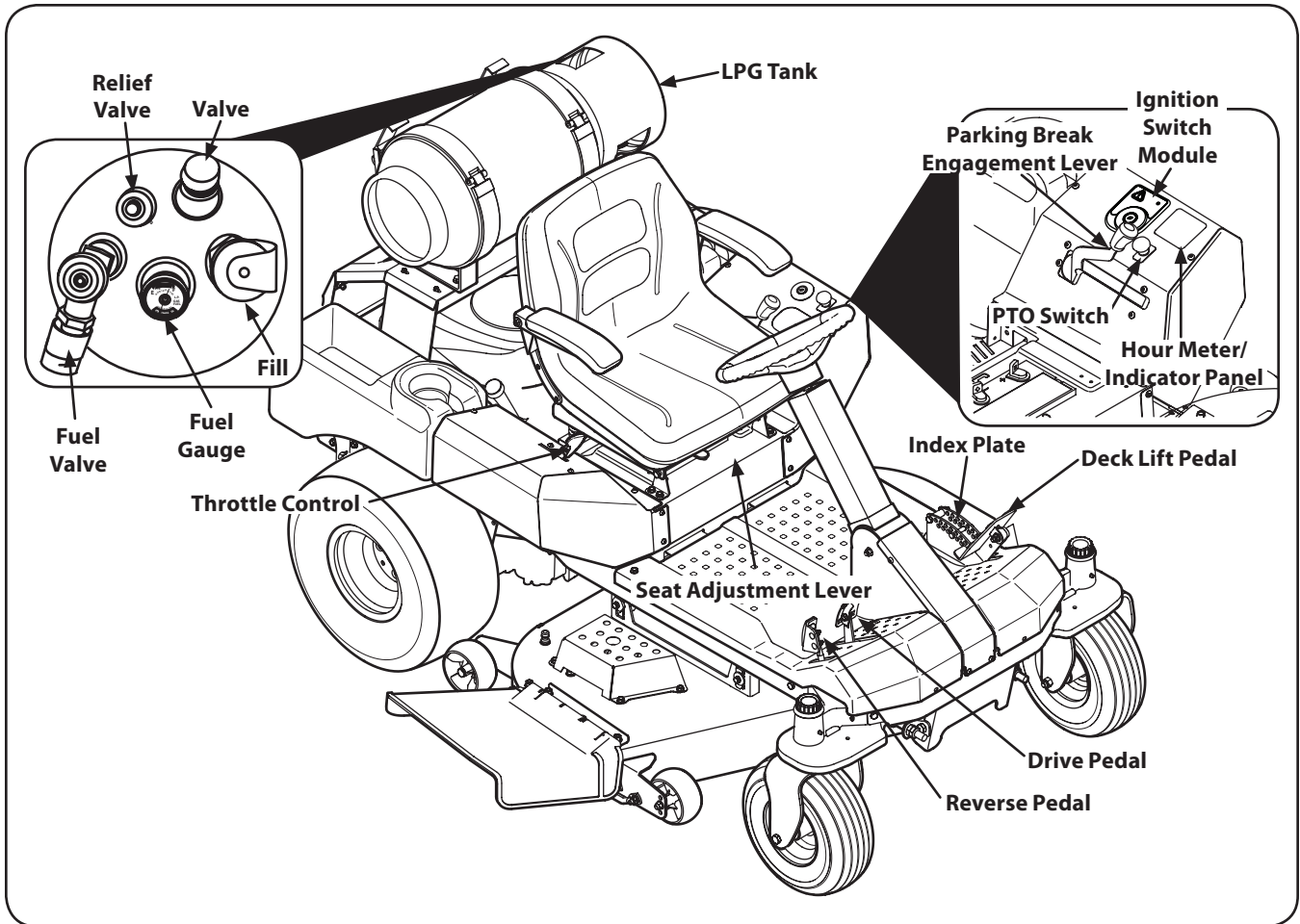
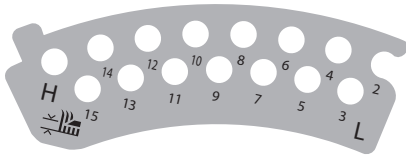

Figure 4-1

NOTE: References to LEFT, RIGHT, FRONT, and REAR indicate that position on the tractor when facing forward while seated in the operator's seat.

Deck Lift Pedal



The deck lift pedal is located near the front of the tractor on the left of the foot platform and is used to raise and lower the mower deck. The deck lift pedal has 17 positions including the transport position.

Push the pedal forward and rock back to lock into the transport position, locking behind the notch on the front of the index plate. Remove and replace the lock pin into the desired height index hole, then push pedal forward and rock forward to unlock and slowly allow the pedal to move back until it reaches the lock pin.

Ignition Switch Module



WARNING! Never leave a running machine unattended. Always disengage PTO, set parking brake, stop engine and remove key to prevent unintended starting.

To start the engine, insert the key into the ignition switch and turn clockwise to the START position. Release the key into the NORMAL MOWING MODE position once the engine has fired.

To stop the engine, turn the ignition key counter-clockwise to the STOP position.



CAUTION: Prior to operating the tractor, refer to both Safety Interlock Switches and Starting The Engine in the Operation section of this manual for detailed instructions regarding the Ignition Switch Module and operating the tractor in REVERSE CAUTION MODE.

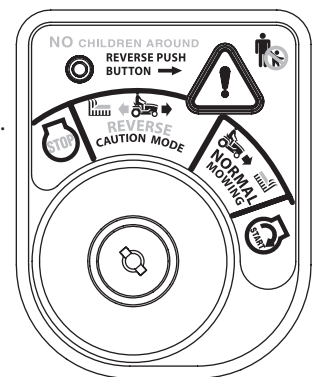

PTO (Power Take-Off) Switch

The PTO switch is located on the LH console to the left of the operator's seat.

The PTO switch operates the electric PTO clutch mounted on the bottom of the engine crankshaft. Pull the switch knob upward to engage the PTO clutch, or push the knob downward to disengage the clutch.

The PTO switch must be in the "disengaged" position when starting the engine.

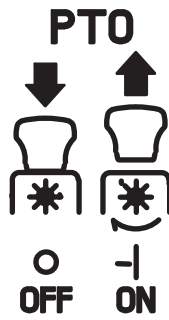

Transmission Bypass Rods (Not Visible)

The transmission bypass rods (one for each the RH and LH transmission) are located on the rear of the tractor, just inside each rear wheel, below the storage trays.

When engaged, the two rods open a bypass within the hydrostatic transmissions, which allows the tractor to be pushed short distances by hand.



CAUTION: Never tow your tractor. Towing the tractor with the rear wheels on the ground may cause severe damage to the transmissions.

Cup Holder

The cup holder is located on the LH console to the left of the operator's seat.

Storage Tray

The storage tray is located at the rear of the LH console.

Seat Adjustment Lever

The seat adjustment lever is located below the front/left of the seat. The lever allows for adjustment of the fore to aft position of the operator's seat. Refer to the Maintenance & Adjustments section for instructions on adjusting the seat position.

Fuel Valve

The fuel valve is located on the front of the LPG Tank. When turned in a clockwise direction until it stops, it will shut off the flow of fuel to the engine. When turned in a counter-clockwise direction it will open and allow fuel to flow to the engine.

Fuel Gauge

Located on the front of the LPG tank, the fuel gauge measures the fuel level in each tank.

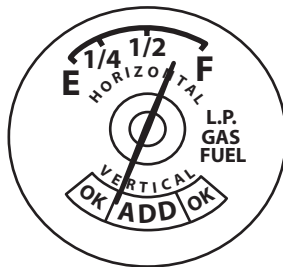

Hour Meter/Indicator Panel

The hour meter/indicator panel is located on the LH console to the left of the operator's seat.

Hour Meter Features

The hour meter records the hours that the tractor has been operated in the digital display (tenths of an hour - right most digit).

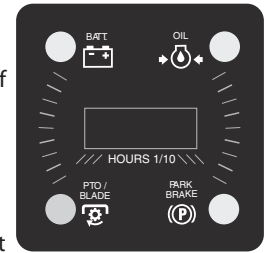

NOTE: The hour meter is activated whenever the ignition switch is turned to the "ON" position. Keep a record of the actual hours of operation to assure all maintenance procedures are completed according to the instructions in this manual and the engine manual.

When key is turned to the "ON" position, the battery indicator light briefly illuminates and the battery voltage is briefly displayed. The display then changes to the accumulated hours.

The Indicator Monitor will also remind the operator of maintenance intervals for changing the engine oil. The LCD will alternately flash, "CHG"; "OIL" and the recorded hours for five minutes after every 50 hours of recorded operation. The maintenance interval lasts for two hours (from 50-52, 100-102, 150-152, etc.). The LCD will flash as described for five minutes every time the tractor's engine is started during this maintenance interval. Follow the oil change intervals provided in the engine manual.

Indicator Panel Features

Battery Indicator

Illuminates and the battery voltage is displayed briefly when the ignition switch is turned to the "ON" position.

Illuminates to indicate the battery voltage has dropped below 11.5 (+0.5/-1.0) volts. The battery voltage is also displayed on the hour meter. If this indicator and display come on during operation, check the battery and charging system for possible causes and/or contact your Cub Cadet dealer.

Oil Pressure Indicator (If Engine So Equipped)

This warning lamp indicates low engine oil pressure. If the indicator comes on while the engine is running, stop the engine immediately and check for possible causes. Do not run the engine while this indicator is illuminated. Contact your Cub Cadet dealer to have the tractor and engine inspected.

NOTE: The oil pressure indicator may illuminate when the ignition switch is in the ON position, but should turn off when the engine is started.

PTO Engaged Indicator

This indicator illuminates when the PTO switch is pulled upward in the "ENGAGED" position and the ignition switch is turned to the "START" position. Check this indicator if the engine will not crank with the ignition switch in the "START" position. If necessary, move the PTO switch to the "DISENGAGED" position.

Parking Brake Engaged Indicator

This indicator illuminates when the parking brake is in the DISENGAGED position and the ignition switch is turned to the "START" position. Check this indicator if the engine will not crank with the ignition switch in the "START" position. If necessary, move the parking brake to the ENGAGED position.

This indicator also illuminates when the ignition switch is turned to the "START" position and the RH and/or LH drive control levers are in a position other than the fully out in neutral position. Move the control levers fully outward.

Throttle Control

The throttle control is located on the RH console to the right of the operator's seat. When set in a given position, a uniform engine speed will be maintained.

Push the throttle control handle forward to increase the engine speed. The tractor is designed to operate with the throttle control in the fast position (full throttle) when the tractor is being driven and the mower deck is engaged.

Pull the throttle control handle rearward to decrease the engine speed.

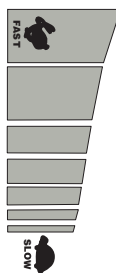

Parking Brake Engagement Lever

The parking brake engagement lever is located on the left of the seat box frame, and is used to engage the parking brake.

Pull the lever rearward to stop the tractor or slow it down.

Pull the lever fully rearward and to the right; then into the short "J" slot to engage the brake.

Pull the lever up out of the "J" slot and to the left; then completely forward to disengage the parking brake.



Drive Pedal

The drive pedal is located on the right side of the tractor, along the running board. Press the drive pedal forward to cause the tractor to travel forward. Ground speed is also controlled with the drive pedal. The further forward the pedal is pivoted, the faster the tractor will travel. The pedal will return to its original position when it's not pressed.



Reverse Pedal

The reverse pedal is located on the right side of the tractor along the running board. Ground speed is also controlled with the reverse pedal. The further downward the pedal is pivoted, the faster the tractor will travel. The pedal will return to its original position when it's not pressed.



General Safety

- **RECEIVE INSTRUCTION** — Entirely read this operator's manual. Learn to operate this machine SAFELY. Do not risk INJURY or DEATH. Allow only those who have become competent in its usage to operate this tractor.
- Before starting the engine or beginning operation, be familiar with the controls. The operator should be in the operator's seat. The PTO switch must be in the disengaged position and the parking brake engaged.
- Keep all shields in place. Keep away from moving parts.
- **NO RIDERS!** Keep all people and pets a safe distance away. Look behind and down to both sides of the tractor before and while backing up.
- **DO NOT** direct the mower discharge at people.
- Avoid slopes where possible. Never operate on slopes greater than 15°. Slopes with a greater incline present dangerous operating conditions. Tractors can be rolled over.
- Before leaving the operator's seat: Shut off the PTO and engage the parking brake, shut off the engine and remove the ignition key. Wait for all movement to stop before servicing or cleaning.
- Avoid any sudden movements of the steering wheel when starting and stopping. Keep a firm grip on the steering wheel.
- Be careful when operating near roadways. Stop the tractor motion and wait for vehicles to pass before operating along the road.
- Do not operate the tractor with the mower deck removed. Removal of the deck will change the balance of the tractor, and could contribute to a tractor rollover.
- Avoid operation on traction surfaces that are unstable; use extreme caution if the surface is slippery.
- Slow down before turning and come to a complete stop before any zero turn maneuver.
- Do not stop the tractor or park the tractor over combustible materials such as dry grass, leaves, debris, etc.

Before Operating Your Tractor

- Before you operate the tractor, study this manual carefully to familiarize yourself with the operation of all the instruments and controls. It has been prepared to help you operate and maintain your tractor efficiently.
- Use only cylinders that meet code #49 of the federal regulation #173.34.
- Use LPG classified HD-5 by National Gas Processors Association (NGPA).
- Check the engine oil level.
- Clean the air cleaner element if necessary.
- Check the tire inflation pressures.
- Adjust the seat for operator's maximum comfort, visibility and for maintaining complete control of the tractor.

Safety Interlock Switches

This tractor is equipped with a safety interlock system for the protection of the operator. If the interlock system should ever malfunction, do not operate the tractor. Contact your Cub Cadet dealer.

- The safety interlock system prevents the engine from cranking or starting unless the parking brake is engaged, and the PTO (Blade Engage) knob is in the disengaged (OFF) position.
- The engine will automatically shut off if the operator leaves the seat before engaging the parking brake.



WARNING! Do not operate the tractor if the interlock system is malfunctioning. This system was designed for your safety and protection.

Starting the Engine



WARNING! This tractor is equipped with a safety interlock system designed for the protection of the operator. Do not operate the tractor if any part of the interlock system is malfunctioning. Periodically check the functions of the interlock system for proper operation.



WARNING! For personal safety, the operator must be sitting in the tractor seat when starting the engine.

1. Open the fuel supply valve.
2. Operator must be sitting in the tractor seat with the speed control pedals in the neutral/start position.
3. Engage the parking brake. See Fig. 5-1.

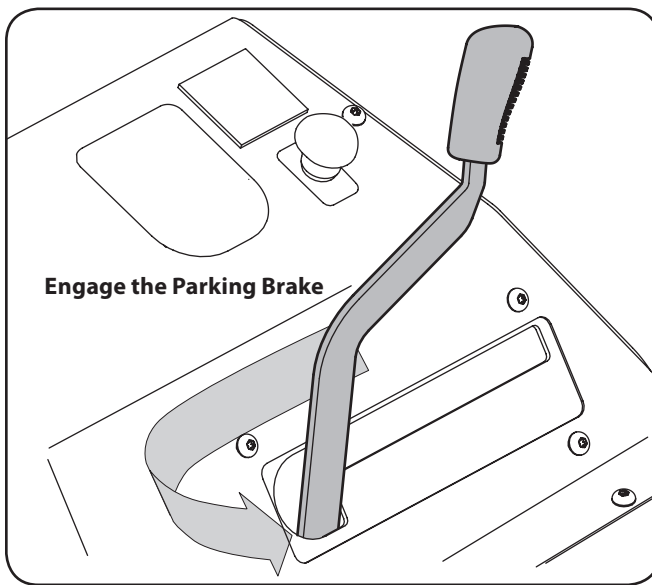

Figure 5-1

4. Make certain the PTO switch is in the disengaged (down) position.
5. Set the throttle in the slow position (slightly faster for cold temperatures).
6. Turn the ignition key clockwise to the "START" position and release it as soon as the engine starts; however, do not crank the engine continuously for more than 15 seconds at a time. If the engine does not start within this time, turn the key to "OFF" and wait at least 30 seconds to allow the engine's starter motor to cool.

Cold Weather Starting

When starting the engine at temperatures near or below freezing, ensure the correct viscosity motor oil is used in the engine and the battery is fully charged. Start the engine as follows:

1. Be sure the battery is in good condition. A warm battery has much more starting capacity than a cold battery.
NOTE: Battery should provide 11.0 VDC during cranking for shut-off valve to function correctly. This also provides desired engine cranking speed.
2. Set the throttle slightly faster than the slow position.
3. Crank engine for about 5 seconds and stop.
4. Wait about 10 seconds, then crank for 15 seconds or until it starts running.
5. Repeat if necessary.

Using Jumper Cables To Start Engine



WARNING! Batteries contain sulfuric acid and produce explosive gasses. Make certain the area is well ventilated, wear gloves and eye protection, and avoid sparks or flames near the battery.

If the battery charge is not sufficient to crank the engine, recharge the battery. If a battery charger is unavailable and the tractor must be started, the aid of a booster battery will be necessary. Connect the booster battery as follows:

1. Connect the end of one cable to the disabled tractor battery's positive terminal; then connect the other end of that cable to the booster battery's positive terminal.
2. Connect one end of the other cable to the booster battery's negative terminal; then connect the other end of that cable to the frame of the disabled tractor, as far from the battery as possible.
3. Start the disabled tractor following the normal starting instructions previously provided; then disconnect the jumper cables in the exact reverse order of their connection.
4. Have the tractor's electrical system checked and repaired as soon as possible to eliminate the need for jump starting.

Stopping the Engine

1. Place the PTO switch in the "OFF" position.
2. Move the speed control pedals to the neutral position.
3. Engage the parking brake.
4. Move the throttle control to midway between the SLOW and FAST positions.
5. Turn the ignition key to the "OFF" position and remove the key from the ignition switch.

NOTE: Always remove the key from the ignition switch to prevent accidental starting or battery discharge if the equipment is left unattended.

6. Close the fuel supply valve.

Driving The Tractor



WARNING! Avoid sudden starts, excessive speed and sudden stops.

1. Release the parking brake. Move the throttle lever into the FAST (rabbit) position.
2. To travel FORWARD, slowly press the drive pedal forward until the desired speed is achieved. See Fig. 5-2.

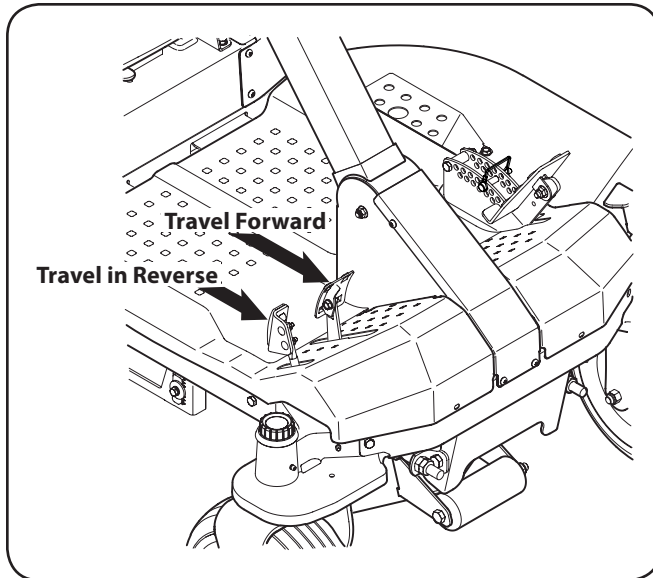

Figure 5-2

3. To stop or slow down the tractor, take your foot off of the forward or reverse drive pedal. To lock the parking brake, pull the lever fully rearward and to the right; then into the short "J" slot to engage the brake. Pull the lever up out of the "J" slot and to the left; then completely forward to disengage the parking brake.

NOTE: The forward and reverse pedals must not be used when the brake is partially engaged. When the brake is locked in the "J" the drive belt is disengaged but if the brake is only part way back then the brakes are engaged but so is the drive belt so transmission damage will occur if you push forward or reverse.

4. To travel in REVERSE, check that the area behind is clear then slowly reverse pedal with the ball of your foot (NOT your heel) until the desired speed is achieved. See Fig. 5-2.



CAUTION: Do NOT attempt to change the direction of travel when the tractor is in motion. Always bring the tractor to a complete stop before moving the tractor from forward to reverse or vice versa.



WARNING! Do not leave the seat of the tractor without first placing the PTO/Blade Engage knob in the disengaged (OFF) position and engaging the parking brake. If leaving the tractor unattended, also turn the engine off and remove the ignition key.

Reverse Caution Mode

The REVERSE CAUTION MODE position of the key switch module allows the tractor to be operated in reverse with the blades (PTO) engaged.

NOTE: Mowing in reverse is not recommended.



WARNING! Use extreme caution while operating the tractor in the REVERSE CAUTION MODE. Always look down and behind before and while backing. Do not operate the tractor when children or others are around. Stop the tractor immediately if someone enters the area.

To use the REVERSE CAUTION MODE:

NOTE: The operator MUST be seated in the tractor seat.

1. Start the engine as previously instructed on the previous page.
2. Turn the key from the NORMAL MOWING (Green) position to the REVERSE CAUTION MODE (Yellow) position of the key switch module. See Fig. 5-3.

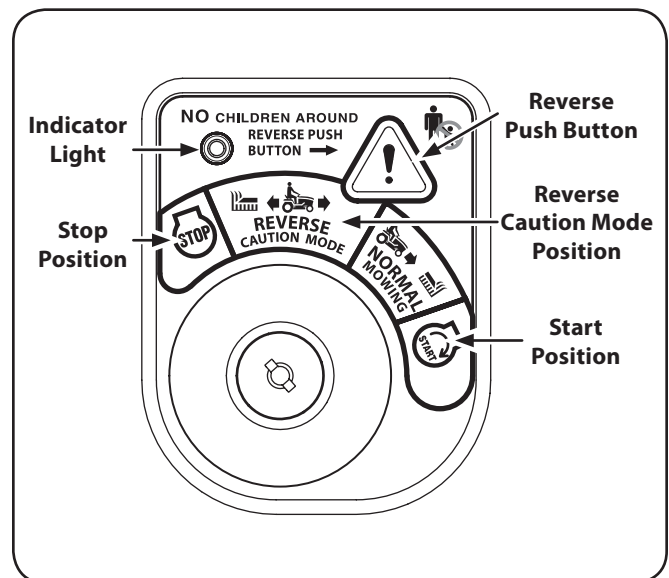

Figure 5-3

3. Press the REVERSE PUSH BUTTON (Orange, Triangular Button) at the top, right corner of the key switch module. The red indicator light at the top, left corner of the key switch module will be ON while activated. See Fig. 5-3.
4. Once activated (indicator light ON), the tractor can be driven in reverse with the cutting blades (PTO) engaged.
5. Always look down and behind before and while backing to make sure no children are around. After resuming forward motion, return the key to the NORMAL MOWING position.

The REVERSE CAUTION MODE will remain activated until:

- a. The key is placed in either the NORMAL MOWING position or STOP position or
- b. The operator leaves the seat.

Driving On Slopes

Refer to the SLOPE GAUGE on page 8 to help determine slopes where you may operate the tractor safely.



WARNING! Do not mow on inclines with a slope in excess of 15 degrees (a rise of approximately 2-1/2 feet every 10 feet). The tractor could overturn and cause serious injury.

- Mow across slopes, not up and down.
- Exercise extreme caution when changing direction on slopes.
- Watch for holes, ruts, bumps, rocks, or other hidden objects. Uneven terrain could overturn the machine. Tall grass can hide obstacles.
- Do not turn on slopes unless necessary; then turn slowly uphill and use extra care while turning. Turning up a slope greatly increases the chance of a rollover.
- Avoid stopping when driving up a slope. If it is necessary to stop while driving up a slope, start up smoothly and carefully to reduce the possibility of flipping the tractor over backward.

Mowing



WARNING! To help avoid blade contact or a thrown object injury, keep bystanders, helpers, children and pets at least 75 feet from the machine while it is in operation. Stop machine if anyone enters the area.

The following information will be helpful when using the cutting deck with your tractor.



WARNING! Plan your mowing pattern to avoid discharge of materials toward roads, sidewalks, bystanders and the like. Also, avoid discharging material against a wall or obstruction which may cause discharged material to ricochet back toward the operator.

- Do not mow at high ground speed, especially if a mulch kit or grass collector is installed.
- Do not cut the grass too short. Short grass is prone to weed growth and yellows quickly in dry weather.
- Always operate the tractor with the throttle lever in the FAST (rabbit) position while mowing.

- For best results it is recommended that the first two laps be cut with the discharge thrown towards the center. After the first two laps, reverse the direction to throw the discharge to the outside for the balance of cutting. This will give a better appearance to the lawn.
- Do NOT attempt to mow heavy brush and weeds or extremely tall grass. Your tractor is designed to mow lawns, NOT clear brush.
- Keep the blades sharp and replace the blades when worn.

Using the Deck Lift Pedal

Push the pedal forward until it locks into the transport position, locking behind the notch on the front of the index plate. Remove and replace the lock pin into the desired height index hole, then press down on the lift pedal and slowly allow the pedal to move back until it reaches the lock pin.

Engaging the PTO

Engaging the PTO transfers power to the cutting deck or other (separately available) attachments. To engage the PTO:

1. Move the throttle control lever to the FAST (rabbit) position.
2. Pull the PTO/Blade Engage knob outward into the engaged (ON) position. See Fig. 5-4.

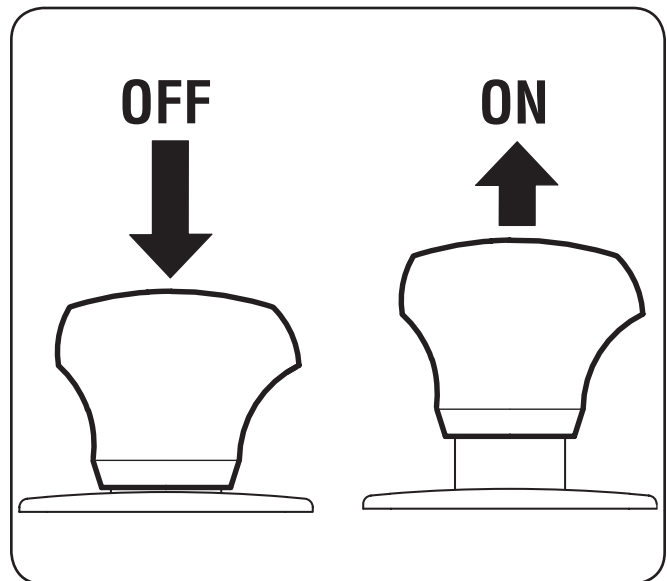

Figure 5-4

NOTE: Always operate the tractor with the throttle lever in the FAST (rabbit) position for the most efficient use of the cutting deck or other (separately available) attachments.

Maintenance & Adjustments

6

Maintenance Schedule

	Before Each use	Every 10 Hours	Every 25 Hours	Every 50 Hours	Every 100 Hours	After Mowing	Prior to Storing
Check engine oil/LPG level	✓	✓					
Check Air Filter for Dirty, Loose or Damaged Parts	✓	✓					
Check LPG valve, hoses and seals	✓						
Check hydraulic hoses for leaks	✓						
Check tires & tire pressure	✓						
Check deck, mower and hydro drive belts	✓						
Check blades and blade bolt tightness	✓						
Check safety switches for proper operation	✓						
Check fluid level in transaxle expansion reservoir	✓						
Check engine intake screen/cover						✓	
Clean mower						✓	
Lube Front Caster Wheels and Wheel Spindles			✓				✓
Clean and Re-oil Air Filter's Foam Precleaner *			✓				
Grease three spindle bearings			✓				
Replace air filter element *					✓		
Change engine oil † and replace oil filter				✓			
Clean Battery Terminals		✓					✓
Clean engine cooling fins & external surfaces *	✓						✓
Lubricate deck spindles			✓				✓
Lube Pedal Pivot Points		✓					✓
Check spark plug condition & gap					✓		

† After first 5 hours, change engine oil & filter. After first 50 hours, change hydrostatic fluid and filter in transaxles. Change oil every 25 hours under heavy duty operation. * Perform more frequently under dusty conditions.

Maintenance



WARNING! Before performing any maintenance or repairs, disengage PTO, set parking brake, stop engine and remove key to prevent unintended starting.

Engine

Contact Cub Cadet Customer Service for engine issues. Refer to page 2 for more information.

Refer to the Kawasaki Owner's Manual for all engine maintenance procedures and instructions.

NOTE: Maintenance, repair, or replacement of the emission control devices and systems which are being done at owner's expense may be performed by any engine repair establishment or individual. Warranty repairs must be performed by a Cub Cadet Dealer.

Changing the Engine Oil



WARNING! If the engine has been recently run, the engine, muffler and surrounding metal surfaces will be hot and can cause burns to the skin. Exercise caution to avoid burns.

NOTE: The oil filter should be changed at every oil change interval.

To complete an oil change, proceed as follows:

1. Run the engine for a short time to warm the engine oil. The oil will flow more freely and carry away more impurities. Use care to avoid burns from hot oil.
2. Locate the oil drain port on the right side of the engine.
3. Pop open the protective cap on the end of the oil drain valve to expose the drain port. Refer to Figure 6-1. Remove the oil fill cap/dipstick from the oil fill tube.

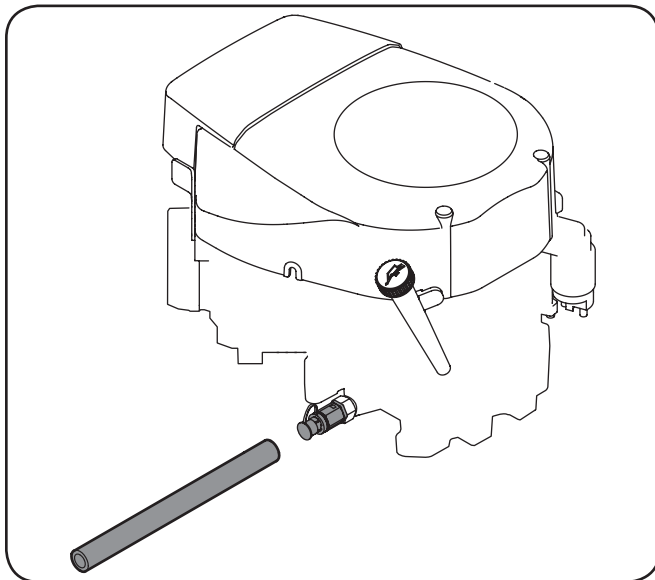

Figure 6-1

4. Push the oil drain hose (packed with this manual) onto the oil drain port. Route the opposite end of the hose into an appropriate oil collection container with at least a 2.0 quart capacity, to collect the used oil.

5. Turn the oil drain valve ¼-turn, then pull outward to begin draining oil. After the oil has finished draining, push the end of the oil drain valve back in and turn ¼-turn to secure it back in place. Re-cap the end of the oil drain valve to keep debris from entering the drain port.
6. After the oil has finished draining, push the end of the oil drain valve back in, until the tabs click into place. Re-cap the end of the oil drain valve to keep debris from entering the drain port.
7. Replace the oil filter, and refill the engine with new oil as instructed in the Kawasaki Owner's Manual.

Changing the LPG Tank



WARNING! If the engine has been recently run, the engine, muffler and surrounding metal surfaces will be hot and can cause burns to the skin. Exercise caution to avoid burns.

To change or remove the LPG tank proceed as follows:

1. Make sure the tractor is off and the key is removed from the ignition.
2. Ensure that the fuel supply valve is turned off.
3. Remove the regulator hose from the LPG tank by twisting it clockwise (A). See Fig. 6-2.

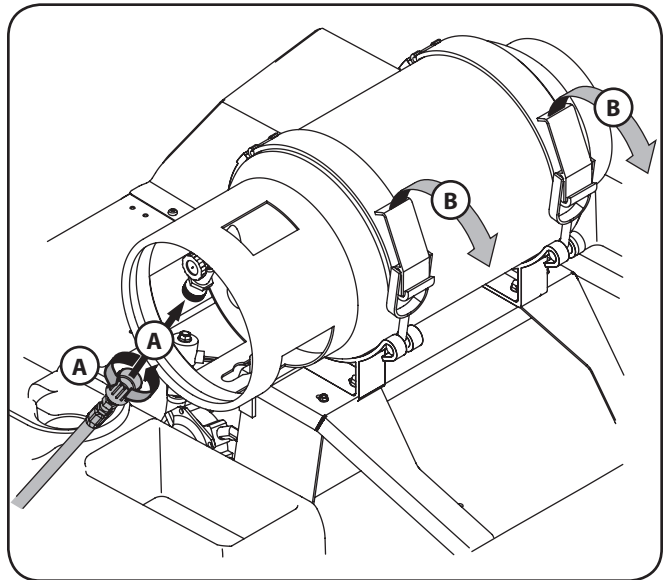

Figure 6-2

NOTE: The hose has left-handed threads to prevent improper usage.

4. Release the two (2) straps that secure the cylinder to the machine (B). See Fig. 6-2.
5. Carefully lift cylinder straight up to remove from machine.
6. Transport tank to an authorized LPG fueling station for refueling.



DANGER! An overfilled cylinder can cause a fire or explosion.

- If exchanging tanks, be sure to use cylinders that contain LPG classified as HD-5 by National Gas Processors Association (NGPA) and cylinders that are designed & patented specifically for lawn care use as a vapor-delivery system.

NOTE: See Initial LPG Tank Fill-Up in the Assembly & Set-Up section for information on new, previously un-filled tanks.

- To re-install the tank, reverse the above instructions but make sure the alignment pin fits into the slot on the bottom of the cylinder valve guard.



WARNING! Be sure to check for leaks after installing tank. Leaks must never be checked with a flame. Always check for seal compromise with a spray bottle filled with soapy water and look for bubbles.

Air Cleaner

Service the pre-cleaner and cartridge/air cleaner element as instructed in the Kawasaki Owner's Manual.

Spark Plug(s)

The spark plug should be cleaned and the gap reset once a season. Refer to the Kawasaki Owner's Manual for correct plug type and gap specifications.

Hydrostatic Transmission

The hydrostatic transmission is sealed at the factory and is maintenance-free. The fluid level cannot be checked and the fluid cannot be changed.

Battery



CALIFORNIA PROPOSITION 65 WARNING!

Battery posts, terminals, and related accessories contain lead and lead compounds, chemicals known to the State of California to cause cancer and reproductive harm. Wash hands after handling.

The battery is sealed and is maintenance-free. Acid levels cannot be checked and fluid can not be added.

- Always keep the battery cables and terminals clean and free of corrosive build-up.
- After cleaning the battery and terminals, apply a light coat of petroleum jelly or grease to both terminals.



CAUTION: If removing the battery for cleaning, disconnect the NEGATIVE (Black) wire from its terminal first, followed by the POSITIVE (Red) wire. When re-installing the battery, always connect the POSITIVE (Red) wire its terminal first, followed by the NEGATIVE (Black) wire. Be certain that the wires are connected to the correct terminals; reversing them could result in serious damage to your engine's alternating system.

Battery Storage

- When storing the tractor for extended periods, disconnect the negative battery cable. It is not necessary to remove the battery.
- All batteries discharge during storage. Keep the exterior of the battery clean, especially the top. A dirty battery will discharge more rapidly.

- The battery must be stored with a full charge. A discharged battery can freeze sooner than a charged battery. A fully charged battery will store longer in cold temperatures than hot.
- Recharge the battery before returning to service. Although the tractor may start, the engine charging system may not fully recharge the battery.

Tractor Storage

If your tractor is not going to be operated for an extended period of time (thirty days to approximately six months), the tractor should be prepared for storage. Store the tractor in a dry and protected location. If stored outside, cover the tractor (including the tires) to protect it from the elements. The procedures outlined below should be performed whenever the tractor is placed in storage.

- Change the engine oil and filter following the instructions provided in the engine manual packed with this manual.



WARNING! Never store the tractor with fuel in the tank indoors or in poorly ventilated enclosures, where fuel fumes may reach an open flame, spark or pilot light as on a furnace, water heater, clothes dryer, etc.

- If storing the tractor for 30 days or more:
 - The LPG tank must be removed and safely stored.
 - Emptying the fuel system:
 - Prior to putting the tractor in storage, monitor fuel consumption with the goal of running the LPG tank empty.
 - Close the fuel valve and disconnect the hose from the LPG tank.
 - Start the engine and allow it to run out of fuel. This will prevent gum and varnish deposits from forming. Replace the fuel filter.
- Clean the engine and the entire tractor thoroughly.
- Fully charge the battery, then disconnect the negative cable at the battery to prevent possible discharge. Recharge the battery periodically when in storage.
- Lubricate all lubrication points.

NOTE: Remove the battery if exposed to prolonged periods of sub-freezing temperatures. Store in a cool, dry location where temperatures are above freezing.

NOTE: Using a pressure washer or garden hose is not recommended for cleaning your tractor. They may cause damage to electrical components, spindles, pulleys, bearings or the engine. The use of water will result in shortened life and reduce serviceability.

Removing The Tractor From Storage

- Check the engine oil.
- Install the LPG tank and check the fuel level.
- Fully charge the battery and inflate the tires to the recommended pressure.
- Start the engine and allow to idle for a few minutes to ensure engine is operating properly.
- Drive the tractor without a load to make certain all the tractor systems are functioning properly.

Cleaning the Tractor

Any oil spilled on the machine should be wiped off promptly. Do NOT allow debris to accumulate around the cooling fins of the engine, the transmission's cooling fan or on any other part of the machine, especially the belts and pulleys.

Smart Jet™

Your tractor's deck is equipped with a water port on its surface as part of its deck wash system.

Use the Smart Jet™ to rinse grass clippings from the deck's underside and prevent the buildup of corrosive chemicals. Complete the following steps AFTER EACH MOWING:

1. Drive the tractor to a level, clear spot on your lawn, near enough for your garden hose to reach.



CAUTION: Make certain the tractor's discharge chute is directed AWAY from your house, garage, parked cars, etc.

1. Disengage the PTO (Blade Engage), set the parking brake and stop the engine.
2. Thread the hose coupler (packaged with your tractor's Operator's Manual) onto the end of your garden hose.
3. Attach the hose coupler to the water port on your decks surface. See Fig. 6-3.

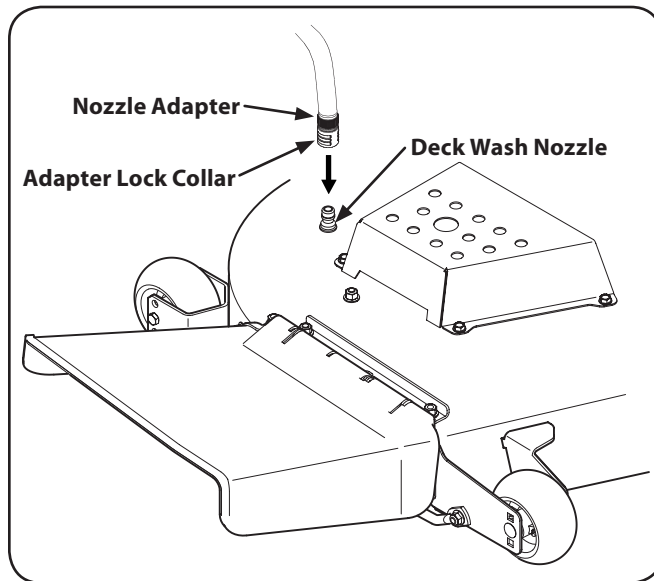

Figure 6-3

4. Turn the water on.
5. While sitting in the operator's position on the tractor, start the engine and place the throttle lever in the FAST (rabbit) position.

6. Move the tractor's PTO (Blade Engage) into the ON position.
7. Remain in the operator's position with the cutting deck engaged for a minimum of two minutes, allowing the underside of the cutting deck to thoroughly rinse.
8. Move the tractor's PTO (Blade Engage) into the OFF position.
9. Turn the ignition key to the STOP position to turn the tractor's engine off.
10. Turn the water off and detach the hose coupler from the water port on your deck's surface.
11. Repeat step 4-10 on the opposite side of the cutting deck.

After cleaning your deck with the Smart Jet™ system, return to the operator's position and engage the PTO. Keep the cutting deck running for a minimum of two minutes, allowing the underside of the cutting deck to thoroughly dry.

Lubrication



WARNING! Before lubricating, repairing, or inspecting, always disengage PTO, set parking brake, stop engine and remove key to prevent unintended starting.

Front Wheels

Each of the front wheel spindles and rims is equipped with a grease fitting. See Fig. 6-4. Lubricate with a No. 2 multi-purpose grease applied with a grease gun after every 25 hours of tractor operation.

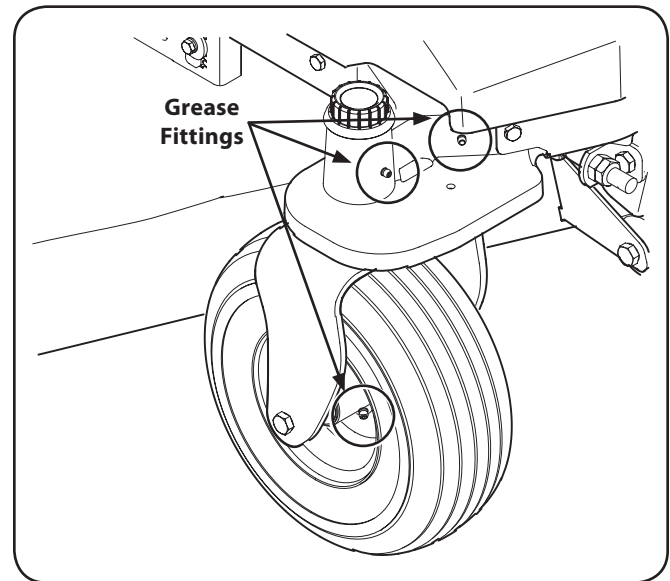

Figure 6-4

Pivot Points & Linkage

Lubricate all the pivot points on the drive system, parking brake and lift linkage at least once a season with light oil.

Deck Spindle

Grease fittings can be found on each deck spindle. See Fig. 6-5. Lubricate with 251H EP grease or an equivalent No. 2 multi-purpose lithium grease. Using a grease gun, apply two strokes (minimum) or sufficient grease to the spindle shaft.

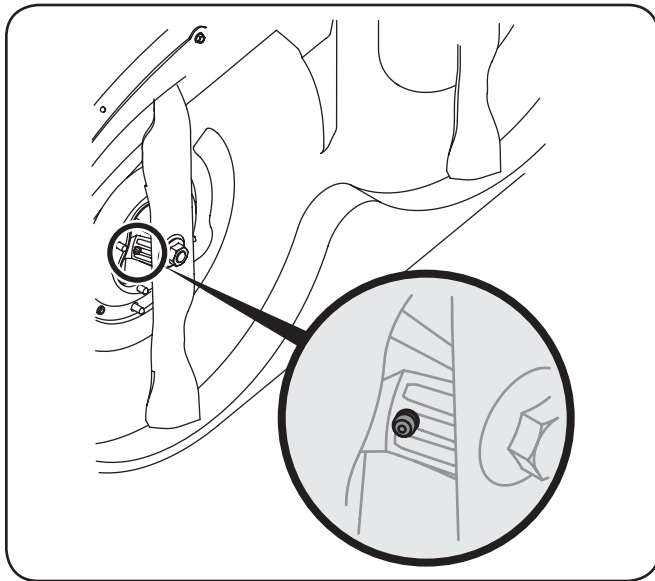

Figure 6-5

Tires



WARNING! Never exceed the maximum inflation pressure shown on the sidewall of the tire.

Refer to the tire sidewall for exact tire manufacturer's recommended or maximum psi. Do not overinflate. Uneven tire pressure could cause the cutting deck to mow unevenly.

Adjustments

NOTE: Check the tractor's tire pressure before performing any deck leveling adjustments. Refer to Tires on page 21 for information regarding tire pressure.



WARNING! Shut the engine off, remove the ignition key and engage the parking brake before making adjustments. Protect your hands by using heavy gloves when handling the blades.

Leveling the Deck (Side to Side)

NOTE: Check the tractor's tire pressure before performing any deck leveling adjustments. Refer to Tires on page 21 for information regarding tire pressure. Always level the deck side to side before front to rear.

NOTE: When leveling the deck side-to-side, make sure the two rear adjustment gears are set in the middle of the adjustment range.

If the cutting deck appears to be mowing unevenly, a side to side adjustment can be performed. Adjust if necessary as follows:

1. With the tractor parked on a firm, level surface, place the deck lift pedal in a middle mowing position and rotate both outside blades so that they are perpendicular with the tractor.

2. Measure the distance from the outside of the left blade tip to the ground and the distance from the outside of the right blade tip to the ground. Both measurements taken should be equal. If they're not, proceed to the next step.
3. Loosen, but do NOT remove, the hex bolt on the front left deck hanger link. See Fig. 6-6.

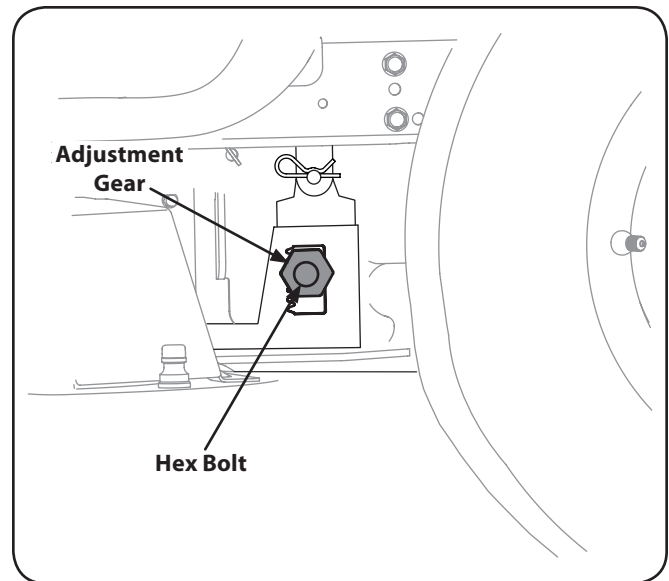

Figure 6-6

NOTE: The front right deck hanger link is not adjustable and is used to help adjust the other hanger links.

4. Using a wrench, raise or lower the left side of the deck by turning the adjustment gears. See Fig. 6-6.

The deck is properly leveled when both blade tip measurements are equal. Retighten the hex bolt on the front left deck hanger bracket when proper adjustment is achieved.

Leveling the Deck (Front To Rear)

NOTE: Check the tractor's tire pressure before performing any deck leveling adjustments. Refer to Tires on page 21 for information regarding tire pressure. Always level the deck side to side before front to rear.

The front of the deck should be between $\frac{1}{4}$ " and $\frac{3}{8}$ " lower than the rear of the deck. Adjust if necessary as follows:

1. Park the tractor on a firm, level surface and place the deck lift pedal in a middle position.
2. Rotate the blade nearest the discharge chute so that it is parallel with the tractor.
3. Measure the distance from the front of the blade tip to the ground and the rear of the blade tip to the ground. The first measurement taken should be between $\frac{1}{4}$ " and $\frac{3}{8}$ " less than the second measurement.
4. Determine the approximate distance necessary for proper adjustment and proceed, if necessary.
5. Loosen, but do NOT remove, the hex bolt on the left and right rear deck hanger brackets. See Fig. 6-6.
6. Using a wrench, raise or lower the left and right side of the deck by turning the adjustment gears. See Fig. 6-6.

- The deck is properly leveled when the front tip of the blade is $\frac{1}{4}$ " lower than the rear tip. Retighten the hex bolt on the left and right rear deck hanger links when proper adjustment is achieved.

Adjusting the Belt Tension

To tighten or loosen the tension on the belt, tighten or loosen the jam nuts on the U-rod, see Fig. 6-7, until a ten-pound pull with a spring scale deflects the belt about $\frac{1}{2}$ ".

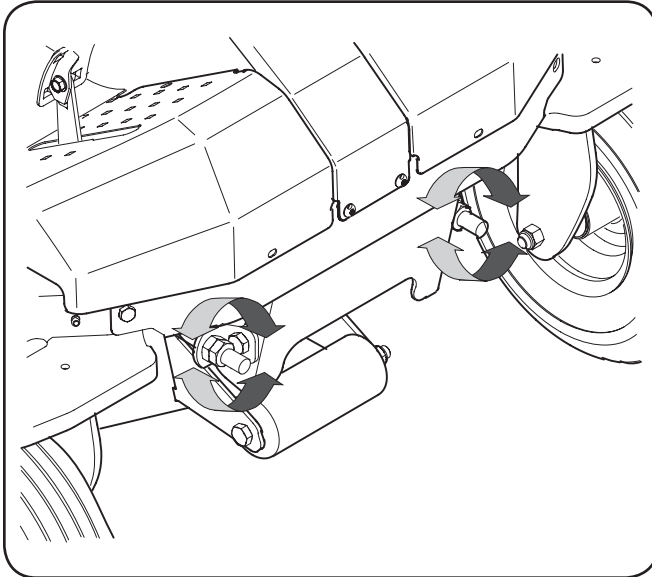

Figure 6-7

Setting the Deck Wheels

Move the tractor on a firm and level surface, preferably pavement, and proceed as follows

- Select the height position of the cutting deck by placing the deck lift pedal in the normally desired mowing height setting.
- Check the deck wheels for contact or excessive clearance with the surface below. The deck wheels should have between $\frac{1}{4}$ - $\frac{1}{2}$ " clearance above the ground.

Parking Brake Adjustment

If the tractor does not come to a complete stop when the brake lever is completely engaged, or if the tractor's rear wheels can roll with the parking brake applied (and the hydrostatic relief valve open), the brake is in need of adjustment. See your Cub Cadet dealer to have the brake properly adjusted.

- If the deck wheels have excessive clearance or contact with the surface, adjust as follows:
 - Raise the deck lift pedal to its highest setting.
 - Remove the front and rear deck wheels by removing the lock nuts and shoulder bolts which secure them to the deck. See Fig. 6-8.

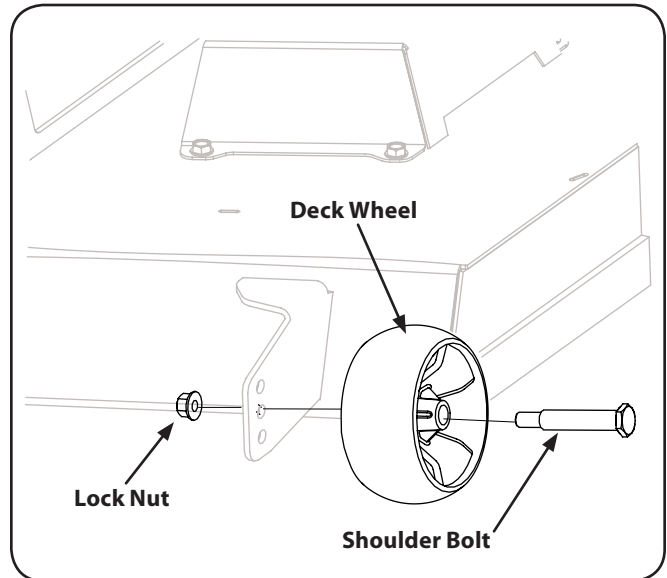

Figure 6-8

- Place the deck lift pedal in the desired mowing height setting.
- Reinsert the shoulder bolts (with each gauge wheel) into the index hole that leaves approximately $\frac{1}{2}$ -inch between the bottom of the wheel and the pavement.

Adjusting the Seat

To adjust the position of the seat, push the seat adjustment lever to the left. Slide the seat forward or rearward to the desired position; then release the adjustment lever. Make sure seat is locked into position before operating the tractor. See Fig. 6-9.

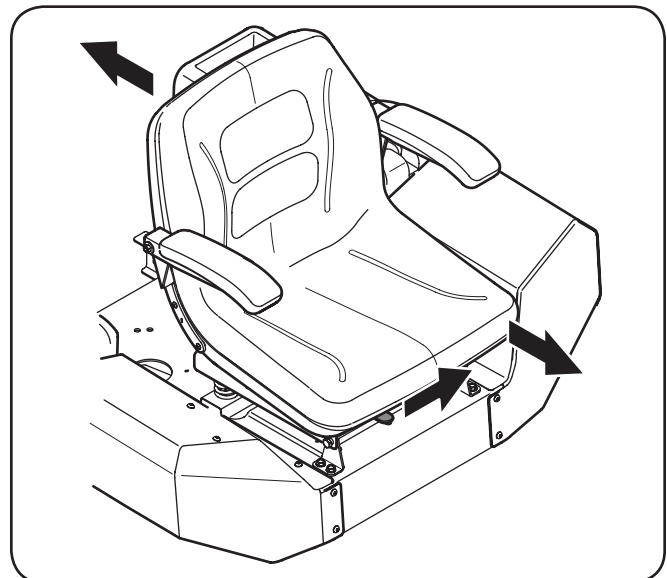

Figure 6-9



WARNING! Before performing any service, place the PTO switch in the “OFF” position, engage the parking brake lever, turn the ignition key to the “OFF” position and remove the key from the switch.

Battery Removal



WARNING! Battery posts, terminals and related accessories contain lead and lead compounds. Wash hands after handling.

The battery is located beneath the seat box frame. To remove the battery:

1. Push down and back on the battery hold-down bracket as shown in Fig. 7-1 to free it from the seat mount frame.

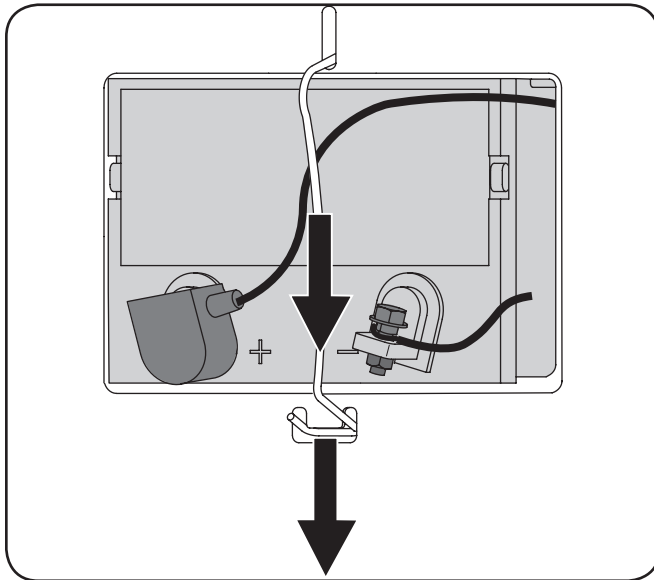

Figure 7-1

2. Remove the hex cap screw and sems nut securing the black negative battery lead to the negative battery post (marked NEG). Move the cable away from the negative battery post.
3. Remove the hex cap screw and sems nut securing the red positive battery lead to the positive battery post (marked POS).
4. Carefully lift the battery out of the tractor.
5. Install the battery by repeating the above steps in the reverse order.



WARNING! Always connect the positive lead to the battery before connecting the negative lead. This will prevent sparking or possible injury from an electrical short caused by contacting the tractor body with tools being used to connect the cables.

Charging the Battery

Test and, if necessary, recharge the battery after the tractor has been stored for a period of time.

- A voltmeter or load tester should read 12.6 volts (DC) or higher across the battery terminals. See Fig. 7-2.

Voltmeter Reading	State of Charge	Charging Time
12.7	100%	Full Charge
12.4	75%	90 Min.
12.2	50%	180 Min.
12.0	25%	280 Min.

Figure 7-2

- Charge the battery with a 12-volt battery charger at a MAXIMUM rate of 10 amps.

Servicing Electrical System

A fuse is installed to protect the tractor’s electrical system from damage caused by excessive amperage. Always use the same capacity fuse for replacement. If the electrical system does not function, check for a blown fuse.

If you have a recurring problem with blown fuses, have the tractor’s electrical system checked by your Cub Cadet Service Dealer.

Relays and Switches

There are several safety switches in the electrical system. If a function of the safety interlock system described earlier is not functioning properly, have the electrical system checked by your Cub Cadet Service Dealer.

Deck Removal

Remove the mower deck from the tractor as follows:

1. Move the tractor to a level surface, disengage the PTO, stop the engine, and set the parking brake.
2. Place the deck lift pedal in the lowest mowing position and replace the lock pin in front of pedal in the deck height bracket and secure by locking the lock pin. See Fig. 7-3.

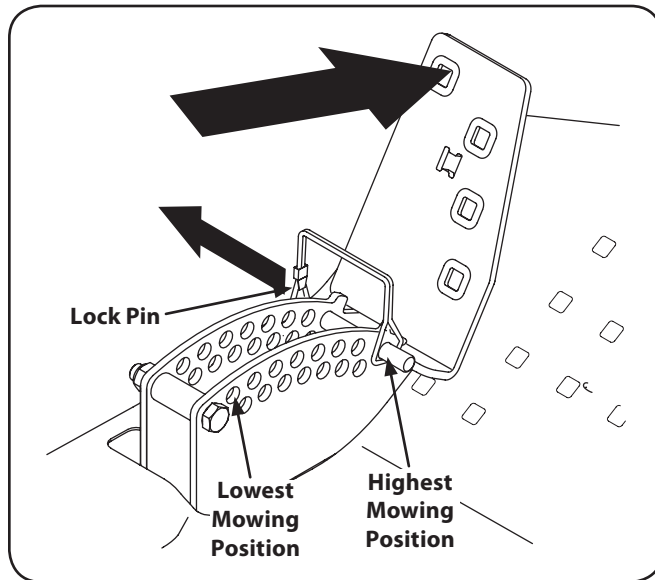

Figure 7-3

3. Using a ½" drive in the idler pulley bracket, turn the wrench towards the back of the tractor and slide the belt off the PTO pulley. See Fig. 7-4.

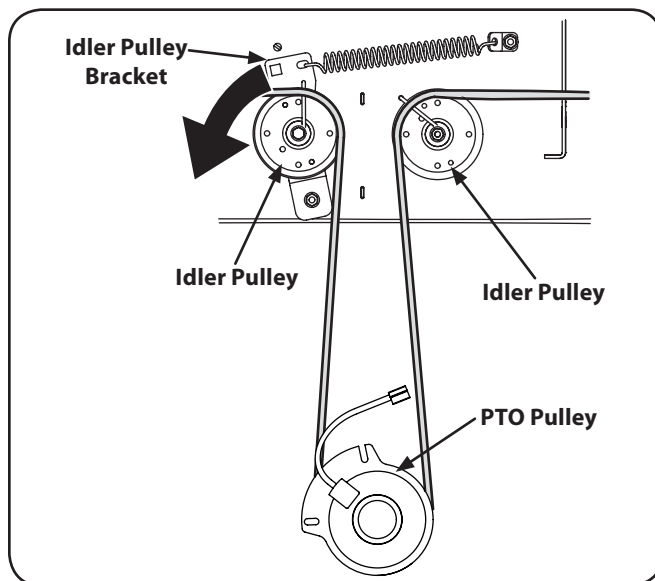

Figure 7-4

4. Once the belt is off the PTO pulley, slide the deck forward and unhook the U-Rod at the nose of the deck.

5. Pull the cotter pins out of the four deck lift adjustment brackets. See Fig. 7-5.

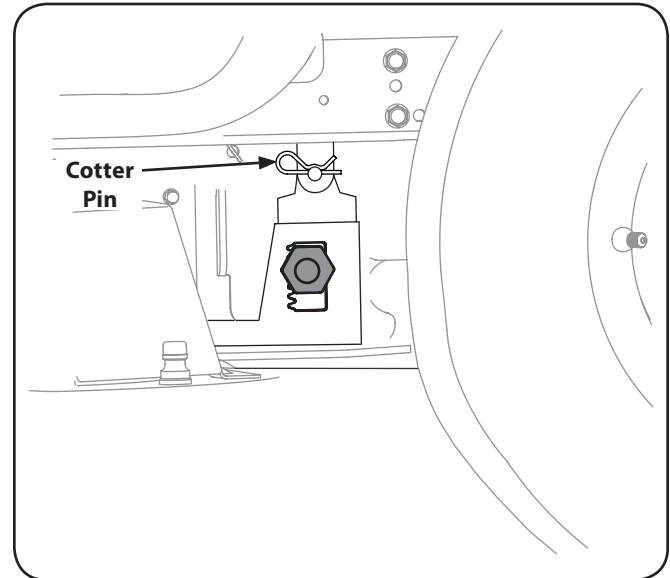

Figure 7-5



CAUTION: The deck lift helper springs will cause the deck lift pedal to slam to the highest position if the click pin is not in front of the pedal.

6. Slide the links off the pins and then slide the deck out from underneath the tractor to the right side.

NOTE: It may be easier to place the deck lift pedal in the transport position when sliding the deck out from underneath the tractor.

Deck Installation

Install the deck on the tractor as follows:

1. Place the deck lift pedal in the highest mowing position and secure it by placing the click pin behind the pedal. Refer to Fig. 7-3.
2. Slide the deck under the tractor on the right side of the tractor lining up the deck lift adjustment brackets and the deck lift brackets on the deck. See Fig. 7-6.

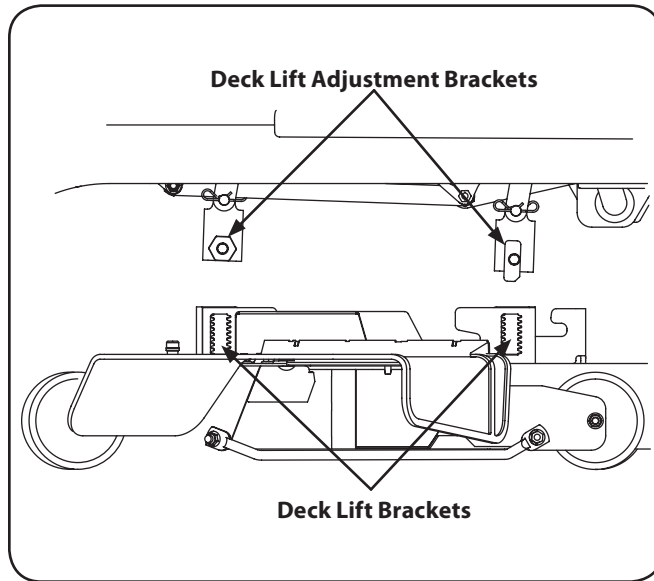

Figure 7-6

3. Once the deck is under the tractor, move the deck lift pedal to the lowest mowing position.

NOTE: To make the brackets line up properly it may be necessary to place a small block of wood under each side of the deck.
4. Once the brackets are properly aligned, slide the pin on the deck lift adjustment bracket into the lift bracket and secure with cotter pins. See Fig. 7-7.

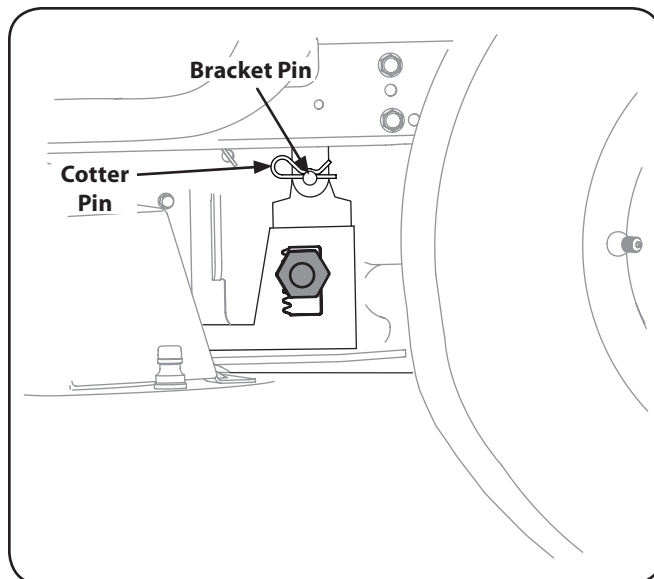

Figure 7-7

5. After all four cotter pins are secure, slide the deck forward and hook the deck to the U-rod.
6. Route the belt as shown in Fig. 7-8. After routing the belt around the PTO pulley, use a $\frac{1}{2}$ " drive in the idler pulley bracket and turn towards the back of the tractor to finish routing the belt around the idler pulley.

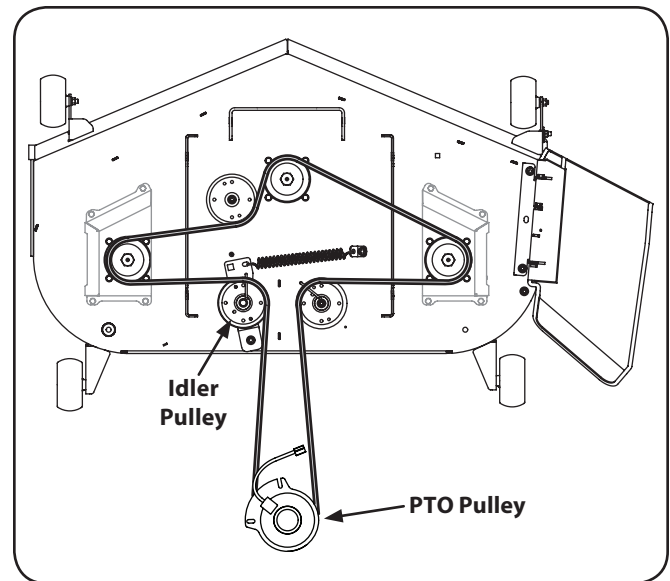

Figure 7-8

7. Place the deck in the highest mowing position by removing the click pin and push the pedal forward and rock back to lock into the transport position, locking behind the notch on the front of the index plate.
8. Refer to the Maintenance & Adjustments section to level the deck if required.
9. Make sure the proper tension is on the belt. To adjust the tension, refer to "Adjusting Belt Tension" on page 22.

NOTE: Before using the tractor double-check the belt routing to make sure that the belt has been routed properly.

Replacing the Belt

1. Remove the deck from beneath the tractor, (refer to Deck Removal on page 24).
2. Remove the hex washer screws securing the belt covers to the deck and loosen the belt keepers enough to slide the belt off the pulleys. See Fig. 7-9.

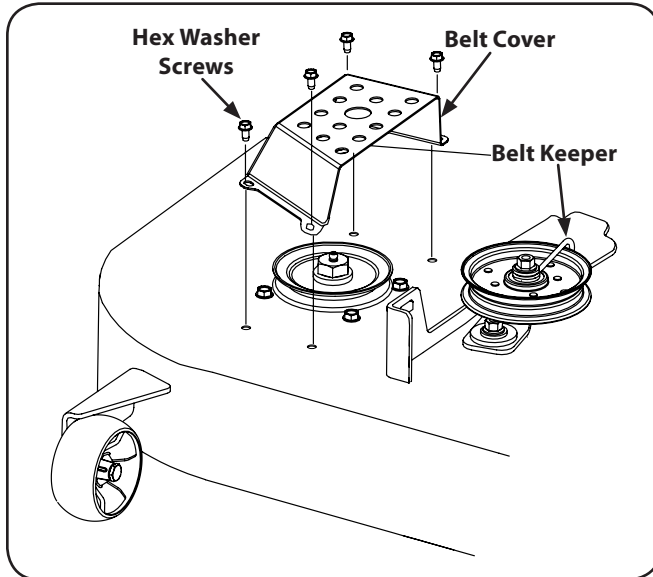

Figure 7-9

3. Remove the belt from the spindle pulleys. Refer to Fig. 7-9.
4. Install the new belt around the spindle pulleys as shown in Fig. 7-8 and reinstall the belt covers.
5. Reinstall the deck following the instructions in Deck Installation on page 26.

Mower Blade Care



WARNING! Protect your hands by using heavy gloves when handling the blades. When servicing the mower deck, be careful not to cut yourself on the sharpened blades.

The cutting blades must be kept sharp at all times. Sharpen the cutting edges of the blades evenly so that the blades remain balanced and the same angle of sharpness is maintained.

If the cutting edge of a blade has already been sharpened many times, or if any metal separation is present, it is recommended that new blades be installed. New blades are available at your authorized dealer.

The blades may be removed as follows.

1. Remove the deck from beneath the tractor, (refer to Deck Removal on page 25) then gently flip the deck over to expose its underside.

2. Use a $\frac{3}{4}$ " wrench to hold the hex nut on top of the spindle assembly when loosening the hex nut securing the blade. See Fig. 7-10.

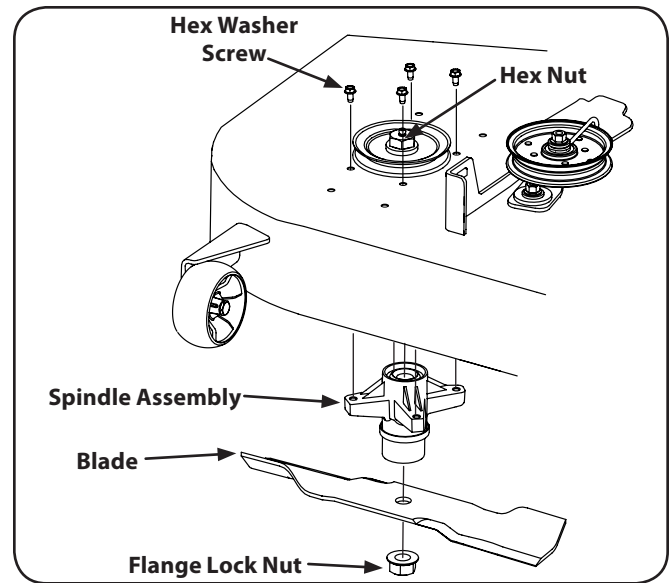

Figure 7-10

3. A block of wood may be placed between the deck housing and the cutting edge of the blade to help in breaking loose the hex nut securing the blade.
4. To reinstall the blades, reverse the above process and tighten nut to 100-120 lb. ft.
5. Reinstall the deck (refer to Deck Installation on page 26).

NOTE: Add a small amount of multi-purpose grease to the bolt threads to avoid corrosion and galvanic action.



WARNING!: Never mow with dull blades. Blades that are bent should be replaced. The cutting blades are sharp and can cause severe injury. Wrap the cutting surface of the blade with a rag to avoid injury.

Sharpening the Blades

1. Remove the deck from beneath the tractor, (refer to Deck Removal on page 25) then gently flip the deck over to expose its underside.
1. Clean any debris from the blades. Keep blades sharp and free of build up at all times.
2. Sharpen blades evenly at the original 30° angle to maintain balanced cutting blades. Do not sharpen the underside of the blades. Use an electric blade sharpener, a conventional electric grinder or a hand file to sharpen the blades.
3. Replace any blade with severe nicks or dents that cannot be removed by filing.
4. Check the balance of the blade after sharpening by placing it on a blade balancer. Do not use unbalanced blades.
5. If the blade dips on one end, file stock off of the cutting surface on that end.

NOTE: Blades that cannot be easily balanced—REPLACE.

Changing the Spindle Assembly

1. Remove the deck from beneath the tractor, (refer to Deck Removal on page 25).
2. Remove the hex washer screws securing the belt covers to the deck and remove the belt from the spindle pulleys. Refer to Fig. 7-10.
1. Remove the drive belt. (See Replacing the Belt)
2. Remove the blade. (See Mower Blade Care).
3. Use a $\frac{3}{4}$ " wrench to hold the hex nut on top of the spindle assembly when loosening the hex nut securing the blade. A block of wood may be placed between the deck housing and the cutting edge of the blade to help in breaking loose the hex nut securing the blade. See Fig. 7-12.

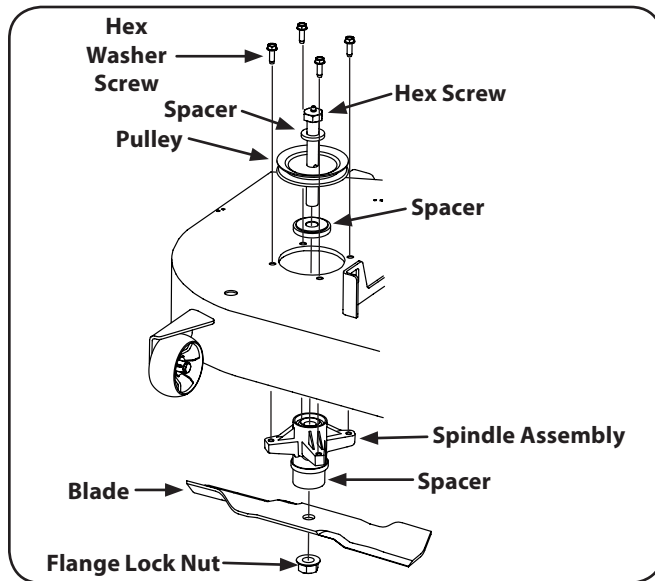

Figure 7-12





NOTE: Take note of the order that the parts composing the assembly are placed.



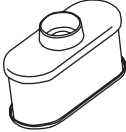

4. Using a wrench or socket ratchet remove four hex washer screws. Remove the spindle assembly. See Fig. 7-12.
5. Reverse the process to install the spindle assembly.

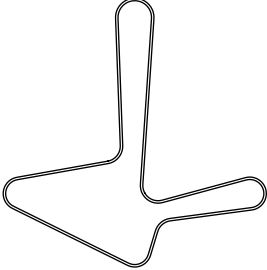
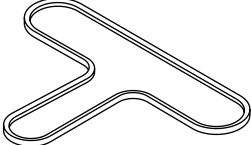
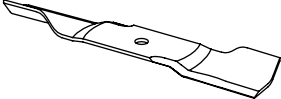
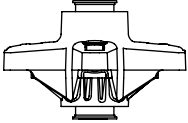
Changing the Transmission Drive Belt

Several components must be removed and special tools used in order to change the tractor's transmission drive belt. See your Cub Cadet dealer to have the transmission drive belt replaced.

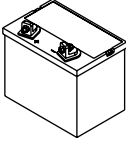
Problem	Cause	Remedy
Engine fails to start	<ol style="list-style-type: none"> 1. PTO/Blade Engage knob engaged. 2. Parking brake not engaged. 3. Spark plug wire(s) disconnected. 4. Throttle control lever not in correct starting position. 5. LPG tank empty, or stale fuel. 6. Blocked fuel line. 7. Faulty spark plug(s). 8. Engine flooded. 	<ol style="list-style-type: none"> 1. Place knob in disengaged (OFF) position. 2. Engage parking brake. 3. Connect wire(s) to spark plug(s). 4. Place throttle lever in the fast position. 5. Replace LPG tank. 6. Clear the blockage. 7. Clean, adjust gap or replace plug(s). 8. Crank engine with throttle in FAST position.
Engine runs erratic	<ol style="list-style-type: none"> 1. Spark plug wire(s) loose. 2. Blocked fuel line or stale fuel. 3. Vent in gas cap plugged. 4. Dirty air cleaner. 	<ol style="list-style-type: none"> 1. Connect spark plug wire(s). 2. Clear the blockage or replace the LPG tank. 3. Clear vent or replace cap if damaged. 4. Replace LPG tank.
Engine overheats	<ol style="list-style-type: none"> 1. Engine oil level low. 2. Air flow restricted. 	<ol style="list-style-type: none"> 1. Fill crankcase with proper amount and weight of oil. 2. Clean grass clippings and debris from around the engine's cooling fins and blower housing.
Engine hesitates at high RPM	<ol style="list-style-type: none"> 1. Spark plug(s) gap too close. 	<ol style="list-style-type: none"> 1. Remove spark plug(s) and reset the gap.
Engine Idles rough	<ol style="list-style-type: none"> 1. Spark plug(s) fouled, faulty or gap too wide. 2. Dirty air cleaner. 	<ol style="list-style-type: none"> 1. Replace spark plug(s). Set plug gap. 2. Replace air cleaner element and/or clean pre-cleaner.
Excessive vibration	<ol style="list-style-type: none"> 1. Cutting blade loose or unbalanced. 2. Damaged or bent cutting blade. 	<ol style="list-style-type: none"> 1. Tighten blade and spindle. 2. Replace blade.
Uneven cut	<ol style="list-style-type: none"> 1. Deck not leveled properly. 2. Dull blade. 3. Uneven tire pressure. 	<ol style="list-style-type: none"> 1. Perform side-to-side deck adjustment. 2. Sharpen or replace blade. 3. Check tire pressure in all four tires.
Mower will not mulch grass (If Equipped w/Mulching Kit)	<ol style="list-style-type: none"> 1. Engine speed too low. 2. Wet grass. 3. Excessively high grass. 4. Dull blade. 	<ol style="list-style-type: none"> 1. Place throttle in FAST (rabbit) position. 2. Do not mulch when grass is wet. 3. Mow once at a high cutting height, then mow again at desired height or make a narrower cutting swath. 4. Sharpen or replace blade.

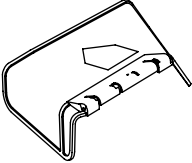
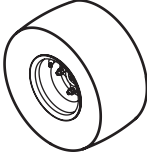
Component	Part Number and Description
	759-3336 Spark Plug
	KM-11013-7047 Air Filter Element
	KM-49065-7006 Oil Filter
	754-04044A Deck Belt
	754-04250 Drive Belt
	02005017 Mowing Blade
	618-04426 Deck Spindle
	734-04155 Deck Wheel

Component	Part Number and Description
	725-1750A Battery
	746-04581 Throttle Control Cable
	725-2054A Ignition Key
	01006693 Chute Deflector
	634-04128 Wheel Assembly
	634-04629 Caster Wheel Assembly

Part No.	Part
19A70011100	48" Double Bagger
19A70018100	Headlight Kit
19A70016100	Mulch Kit
59A30032150	33 lb. LPG Tank Kit (One Tank)

FEDERAL and/or CALIFORNIA EMISSION CONTROL WARRANTY STATEMENT
YOUR WARRANTY RIGHTS AND OBLIGATIONS

MTD Consumer Group Inc, the United States Environmental Protection Agency (EPA), and, for those products certified for sale in the state of California, the California Air Resources Board (CARB) are pleased to explain the emission (evaporative and/or exhaust) control system (ECS) warranty on your outdoor 2006 and later small off-road spark-ignited engine and equipment (outdoor equipment engine) In California, new outdoor equipment engines must be designed, built and equipped to meet the State's stringent anti-smog standards (in other states, 1997 and later model year equipment must be designed, built, and equipped to meet the U.S. EPA small off-road, spark ignition engine regulations. MTD Consumer Group Inc must warrant the ECS on your outdoor equipment engine for the period of time listed below provided there has been no abuse, neglect or improper maintenance of outdoor equipment engine.

Your ECS may include parts such as the carburetor, fuel-injection system, the ignition system, catalytic converter, fuel tanks, fuel lines, fuel caps, valves, canisters, filters, vapor hoses, clamps, connectors, and other associated emission-related components.

Where a warrantable condition exists, MTD Consumer Group Inc will repair your outdoor equipment engine at no cost to you including diagnosis, parts and labor.

MANUFACTURER'S WARRANTY COVERAGE:

This emission control system is warranted for two years. If any emission-related part on your outdoor equipment engine is defective, the part will be repaired or replaced by MTD CONSUMER GROUP INC.

OWNER'S WARRANTY RESPONSIBILITIES:

As the outdoor equipment engine owner, you are responsible for performance of the required maintenance listed in your owner's manual. MTD Consumer Group Inc recommends that you retain all receipts covering maintenance on your outdoor equipment engine, but MTD Consumer Group Inc cannot deny warranty solely for the lack of receipts.

As the outdoor equipment engine owner, you should however be aware that MTD Consumer Group Inc may deny you warranty coverage if your outdoor equipment engine or a part has failed due to abuse, neglect, or improper maintenance or unapproved modifications.

You are responsible for presenting your outdoor equipment engine to MTD Consumer Group Inc's distribution center or service center as soon as the problem exists. The warranty repairs should be completed in a reasonable amount of time, not to exceed 30 days. If you have a question regarding your warranty coverage, you should contact the MTD Consumer Group Inc Service Department at 1-800-800-7310 or via email at <http://support.mtdproducts.com>

GENERAL EMISSIONS WARRANTY COVERAGE:

MTD Consumer Group Inc warrants to the ultimate purchaser and each subsequent purchaser that the outdoor equipment engine is: Designed, built and equipped so as to conform with all applicable regulations; and free from defects in materials and workmanship that cause the failure of a warranted part to be identical in all material respects to that part as described in MTD Consumer Group Inc's application for certification.

The warranty period begins on the date the outdoor equipment engine is delivered to an ultimate purchaser or first placed into service. The warranty period is two years.

Subject to certain conditions and exclusions as stated below, the warranty on emission-related parts is as follows:

1. Any warranted part that is not scheduled for replacement as required maintenance in the written instructions supplied, is warranted for the warranty period stated above. If the part fails during the period of warranty coverage, the part will be repaired or replaced by MTD Consumer Group Inc according to subsection (4) below. Any such part repaired or replaced under warranty will be warranted for the remainder of the period.
2. Any warranted part that is scheduled only for regular inspection in the written instructions supplied is warranted for the warranty period stated above. Any such part repaired or replaced under warranty will be warranted for the remaining warranty period.
3. Any warranted part that is scheduled for replacement as required maintenance in the written instructions supplied is warranted for the period of time before the first scheduled replacement date for that part. If the part fails before the first scheduled replacement, the part will be repaired or replaced by MTD Consumer Group Inc according to subsection (4) below. Any such part repaired or replaced under warranty will be warranted for the remainder of the period prior to the first scheduled replacement point for the part.
4. Repair or replacement of any warranted part under the warranty provisions herein must be performed at a warranty station at no charge to the owner.
5. Notwithstanding the provisions herein, warranty services or repairs will be provided at all of our distribution centers that are franchised to service the subject engines or equipment.
6. The outdoor equipment engine owner will not be charged for diagnostic labor that is directly associated with diagnosis of a defective, emission-related warranted part, provided that such diagnostic work is performed at a warranty station.
7. MTD Consumer Group Inc is liable for damages to other engine or equipment components proximately caused by a failure under warranty of any warranted part.
8. Throughout the off-road engine and equipment warranty period stated above, MTD Consumer Group Inc will maintain a supply of warranted parts sufficient to meet the expected demand for such parts.
9. Any replacement part may be used in the performance of any warranty maintenance or repairs and must be provided without charge to the owner. Such use will not reduce the warranty obligations of MTD Consumer Group Inc.
10. Add-on or modified parts that are not exempted by the Air Resources Board may not be used. The use of any non-exempted add-on or modified parts by the ultimate purchaser will be grounds for disallowing a warranty claims. MTD Consumer Group Inc will not be liable to warrant failures of warranted parts caused by the use of a non-exempted add-on or modified part.

WARRANTED PARTS:

The repair or replacement of any warranted part otherwise eligible for warranty coverage may be excluded from such warranty coverage if MTD Consumer Group Inc demonstrates that the outdoor equipment engine has been abused, neglected, or improperly maintained, and that such abuse, neglect, or improper maintenance was the direct cause of the need for repair or replacement of the part. That notwithstanding, any adjustment of a component that has a factory installed, and properly operating, adjustment limiting device is still eligible for warranty coverage. Further, the coverage under this warranty extends only to parts that were present on the off-road engine and equipment purchased.

The following emission warranty parts are covered (if applicable):

(1) Fuel Metering System

- Cold start enrichment system (soft choke)
- Carburetor and internal parts (or fuel injection system)
- Fuel pump
- Fuel tank

(2) Air Induction System

- Air cleaner
- Intake manifold

(3) Ignition System

- Spark plug(s)
- Magneto ignition system

(4) Exhaust System

- Catalytic converter
- SAI (Reed valve)

(5) Miscellaneous Items Used in Above System

- Vacuum, temperature, position, time sensitive valves and switches
- Connectors and assemblies

(6) Evaporative Control

- Fuel hose
- Fuel hose clamps
- Tethered fuel cap
- Carbon canister
- Vapor lines

CUB CADET LLC

MANUFACTURER'S LIMITED WARRANTY FOR Z-FORCE S/Z-FORCE ZERO-TURN RIDING MOWER

IMPORTANT: To obtain warranty coverage owner must present an original proof of purchase and applicable maintenance records to the servicing dealer. Please see the operator's manual for information on required maintenance and service intervals.

The limited warranty set forth below is given by Cub Cadet LLC with respect to new merchandise purchased or leased and used in the United States and/or its territories and possessions, and by MTD Products Limited with respect to new merchandise purchased or leased and used in Canada and/or its territories and possessions (either entity respectively, "Cub Cadet").

Cub Cadet warrants this product (excluding its *Normal Wear Parts, Batteries and Attachments* as described below) against defects in material and workmanship for a period of three (3) years or one hundred eighty (180) operation hours, whichever comes first, commencing on the date of original retail purchase or lease and will, at its option, repair or replace, free of charge, any part found to be defective in materials or workmanship.

Normal Wear Parts are warranted to be free from defects in material and workmanship for a period of thirty (30) days from the date of original purchase or lease. Normal wear parts include, but are not limited to items such as: belts, blades, blade adapters, grass bags, rider deck wheels, seats, and tires.

Batteries have a one-year prorated limited warranty against defects in material and workmanship, with 100% replacement during the first three months. After three months, the battery replacement credit is based on the months remaining in the twelve (12) month period dating back to the original date of original sale or lease. Any replacement battery will be warranted only for the remainder of the original warranty period.

Attachments — Cub Cadet warrants attachments for this product against defects in material and workmanship for a period of one (1) year, commencing on the date of the attachment's original purchase or lease. Attachments include, but are not limited to items such as: grass collectors and mulch kits.

This limited warranty shall only apply if this product has been operated and maintained in accordance with the Operator's Manual furnished with the product, and has not been subject to misuse, abuse, neglect, accident, improper maintenance, alteration, vandalism, theft, fire, water, or damage because of other peril or natural disaster. Damage resulting from the installation or use of any part, accessory or attachment not approved by Cub Cadet for use with the product(s) covered by this manual will void your warranty as to any resulting damage. In addition, Cub Cadet may deny warranty coverage if the hour meter, or any part thereof, is altered, modified, disconnected or otherwise tampered with.

HOW TO OBTAIN SERVICE: Warranty service is available, WITH PROOF OF PURCHASE AND APPLICABLE MAINTENANCE RECORDS, through your local authorized service dealer. To locate the dealer in your area:

In the U.S.A.:

Check your Yellow Pages, or contact Cub Cadet LLC at P.O. Box 361131, Cleveland, Ohio 44136-0019, call 1-877-282- 8684 or log on to our website at www.cubcadet.com.

In Canada:

Contact MTD Products Limited, Kitchener, ON N2G 4J1, call 1-800-668-1238 or log on to our website at www.mtdcanada.com.

Without limiting the foregoing, this limited warranty does not provide coverage in the following cases:

- Routine maintenance items such as lubricants, filters, blade sharpening, tune-ups, brake adjustments, clutch adjustments, deck adjustments, and normal deterioration of the exterior finish due to use or exposure.
- Service completed by someone other than an authorized service dealer.
- Cub Cadet does not extend any warranty for products sold or exported outside of the United States and/or Canada, and their respective possessions and territories, except those sold through Cub Cadet's authorized channels of export distribution.
- Replacement parts and/or accessories that are not genuine Cub Cadet parts.
- Transportation charges and service calls.

There are no implied warranties, including without limitation any implied warranty of merchantability or fitness for a particular purpose. No warranties shall apply after the applicable period of express written warranty above. No other express warranties beyond those mentioned above, given by any person or entity, including a dealer or retailer, with respect to any product, shall bind Cub Cadet. The exclusive remedy is repair or replacement of the product as set forth above. The terms of this warranty provide the sole and exclusive remedy arising from the sale and/or lease of the products covered hereby. Cub Cadet shall not be liable for any incidental or consequential loss or damage including, without limitation, expenses incurred for substitute or replacement lawn care services or for rental expenses to temporarily replace a warranted product.

Some jurisdictions do not allow the exclusion or limitation of incidental or consequential damages, or limitations on how long an implied warranty lasts, so the above exclusions or limitations may not apply to you.

In no event shall recovery of any kind be greater than the amount of the purchase price of the product sold. **Alteration of safety features of the product shall void this warranty.** You assume the risk and liability for loss, damage, or injury to you and your property and/or to others and their property arising out of the misuse or inability to use the product.

This limited warranty shall not extend to anyone other than the original purchaser or to the person for whom it was purchased as a gift.

HOW LOCAL LAWS RELATE TO THIS WARRANTY: This limited warranty gives you specific legal rights, and you may also have other rights that vary in different jurisdictions.

Cub Cadet LLC, P.O. BOX 361131 CLEVELAND, OHIO 44136-0019, Phone: 1-877-282-8684
MTD Products Limited, Kitchener, ON N2G 4J1, Phone: 1-800-668-1238