

Cub Cadet

Power Equipment

Owner's Manual

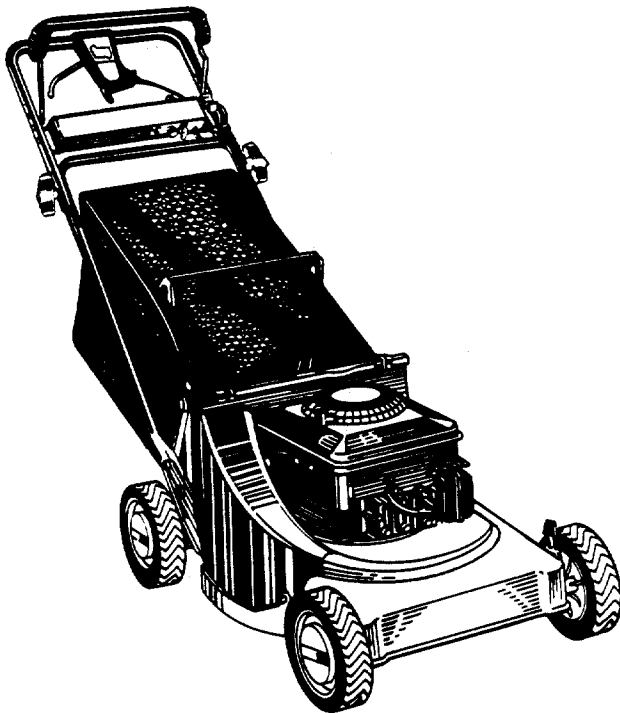

**21"
ELECTRIC START
6 SPEED
CONVERTIBLE
ROTARY MOWER**

**Model Number
898E
(123E898E100)**

Important:
Read Safety Rules and Instructions Carefully

Thank you for purchasing an American-built product.

WARNING: This unit is equipped with an internal combustion engine and should not be used on or near any unimproved forest-covered, brush-covered or grass-covered land unless the engine's exhaust system is equipped with a spark arrester meeting applicable local or state laws (if any). If a spark arrester is used, it should be maintained in effective working order by the operator.

In the State of California the above is required by law (Section 4442 of the California Public Resources Code). Other states may have similar laws. Federal laws apply on federal lands. A spark arrester for the muffler is available through your nearest authorized service dealer.

IMPORTANT

SAFE OPERATION PRACTICES



THIS SYMBOL POINTS OUT IMPORTANT SAFETY INSTRUCTIONS WHICH, IF NOT FOLLOWED, COULD ENDANGER THE PERSONAL SAFETY AND/OR PROPERTY OF YOURSELF AND OTHERS. READ AND FOLLOW ALL INSTRUCTIONS IN THIS MANUAL BEFORE ATTEMPTING TO OPERATE YOUR LAWN MOWER. FAILURE TO COMPLY WITH THESE INSTRUCTIONS MAY RESULT IN PERSONAL INJURY. WHEN YOU SEE THIS SYMBOL—  **HEED ITS WARNING.**



DANGER: Your lawn mower was built to be operated according to the rules for safe operation in this manual. As with any type of power equipment, carelessness or error on the part of the operator can result in serious injury. If you violate any of these rules, you may cause serious injury to yourself or others.

TRAINING



1. Read this owner's guide carefully in its entirety before attempting to assemble or operate this machine. Be completely familiar with the controls and the proper use of this machine before operating it. Keep this manual in a safe place for future and regular reference and for ordering replacement parts.
2. Your rotary mower is a precision piece of power equipment, not a plaything. Therefore, exercise extreme caution at all times. Your unit has been designed to perform one job: to mow grass. Do not use it for any other purpose.
3. Never allow children under 14 years old to operate a power mower. Children 14 years old and over should only operate mower under close parental supervision. Only persons well acquainted with these rules of safe operation should be allowed to use your mower.
4. Keep the area of operation clear of all persons, particularly small children and pets. Stop engine when they are in the vicinity of your mower to help prevent blade contact or thrown object injury. Although the area of operation should be completely cleared of foreign objects, an object may have been overlooked and could be accidentally thrown by the mower in any direction and cause serious personal injury to the operator or any others allowed in the area.

PREPARATION



1. Thoroughly inspect the area where the equipment is to be used. Remove all stones, sticks, wire, bones and other foreign objects which could be picked up and thrown by the mower in any direction and cause serious personal injury to the operator or any others allowed in the area. Plan your mowing pattern to avoid discharge of material toward roads, sidewalks, bystanders and the like.
2. Always wear safety glasses or eye shields during operation or while performing an adjustment or repair, to protect eyes from foreign objects that may be thrown from the machine in any direction.
3. Wear sturdy, rough-soled work shoes and close-fitting slacks and shirts. Shirts and pants that cover the arms and legs and steel-toed shoes are recommended. Do not wear loose fitting clothes or jewelry. They can be caught in moving parts. Never operate a unit in bare feet, sandals, or sneakers.
4. Before working with gasoline, extinguish all cigarettes, cigars, pipes and other sources of ignition. Check the fuel level before starting the engine. Gasoline is an extremely flammable fuel. Do not fill the gasoline tank indoors, while the engine is running, or until engine has been allowed to cool for at least two minutes after running. Replace gasoline cap securely and wipe off any spilled gasoline before starting the engine as it may cause a fire or explosion.
5. Disengage the self-propelled mechanism or drive clutch on units so equipped before starting the engine.
6. The blade control handle is a safety device. Never attempt to bypass its operation. Doing so makes the safety device inoperative and may result in personal injury through contact with the rotating blade. The blade control handle must operate easily in both directions and automatically return to the disengaged position when released.
7. Never attempt to make a wheel or cutting height adjustment while the engine is running.
8. Never operate the mower in wet grass. Always be sure of your footing. A slip and fall can cause serious personal injury. Keep a firm hold on the handle and walk, never run. Mow only in daylight or in good artificial light.

9. For your safety, use the slope gauge included as part of this manual to measure slopes before operating this unit on a sloped or hilly area. If the slope is greater than 15° as shown on the slope gauge, do not operate this unit on that area or serious injury could result.



OPERATION

1. Do not change the engine governor settings or overspeed the engine. Excessive engine speeds are dangerous.
2. Do not put hands or feet near or under rotating parts. Keep clear of the discharge opening at all times as the rotating blade can cause injury.
3. Stop the blade when crossing gravel drives, walks or roads.
4. After striking a foreign object, stop the engine, remove the wire from the spark plug, and thoroughly inspect the mower for any damage. Repair the damage before restarting and operating the mower.
5. If the equipment should start to vibrate abnormally, stop the engine and check immediately for the cause. Vibration is generally a warning of trouble.
6. Shut the engine off and wait until the blade comes to a complete stop before removing the grass catcher or unclogging the chute. The cutting blade continues to rotate for a few seconds after the engine is shut off. Never place any part of the body in the blade area until you are sure the blade has stopped rotating.
7. Before cleaning, repairing or inspecting, make certain the blade and all moving parts have stopped. Disconnect the spark plug wire, and keep the wire away from the spark plug to prevent accidental starting.
8. Do not run the engine indoors.
9. Never cut grass by pulling mower toward you. Mow across the face of slopes, never up-and-down. Exercise extreme caution when changing direction on slopes. Do not mow excessively steep slopes. Always be sure of your footing. A slip and fall can cause serious personal injury.
10. Never operate mower without proper guards, plates or other safety protective devices in place.
11. Muffler and engine become hot and can cause a burn. Do not touch.
12. Do not operate this mower with the chute door open, unless the complete grass catcher or chute deflector is properly mounted on the mower.



MAINTENANCE AND STORAGE

1. Check the blade and engine mounting bolts at frequent intervals for proper tightness. Also visually inspect blade for damage (e.g. bent, cracked). Replace with blade which meets original equipment specifications.
2. Keep all nuts, bolts, and screws tight to be sure the equipment is in safe working condition.
3. Never store the mower with gasoline in the tank or gas containers inside of a building where fumes may reach an open flame or spark (e.g. gas hot water heater). Allow the engine to cool before storing in any enclosure.
4. To reduce fire hazard, keep the engine free of grass, leaves and excessive oil.
5. Check the grass catcher bag frequently for wear or deterioration. Replace a worn or damaged bag immediately. For safety protection, replace only with new bag meeting original equipment specifications.

SET-UP INSTRUCTIONS

IMPORTANT: This unit is shipped **WITHOUT GASOLINE or OIL** in the engine. Be certain to service engine with gasoline and oil before operating your mower.

NOTE: Reference to right or left hand side of the mower is observed from the operating position.

TO REMOVE MOWER FROM CARTON

Remove the carton inserts (if any). Remove the loose parts which are in the carton, lift the mower from the carton, or cut the corners of the carton and roll the mower out.

HOW TO SET-UP YOUR LAWN MOWER

(Refer to Figure 1)

1. Disconnect the spark plug wire and move it away from the spark plug.
2. Remove any cardboard pieces which may be between the upper and lower handles for shipping purposes. If there is any packaging (plastic or cardboard) around the upper handle, remove it.
3. For shipping purposes your mower is set with the wheels in the lowest cutting height position. Raise

the mower to the highest setting for assembly of handle.

4. Remove the hairpin clips which are in the weld pins on the handle mounting brackets.
5. Lift the handle assembly. Attach the handle by placing the bottom holes in the lower handle over the weld pins on the handle mounting brackets. Make certain the lower handle is seated securely into the handle mounting brackets.
6. Pull up on the upper handle to raise it into the operating position. Tighten the hand knobs on each side of the handle.

NOTE: Your mower is shipped with the handle in the higher height position. If you wish to lower the height of the handle, refer to the Adjustment Section at this time.

7. Secure the handle assembly by placing the hairpin clips in the inner hole on weld pins.
8. Make certain all nuts and bolts are tightened securely.

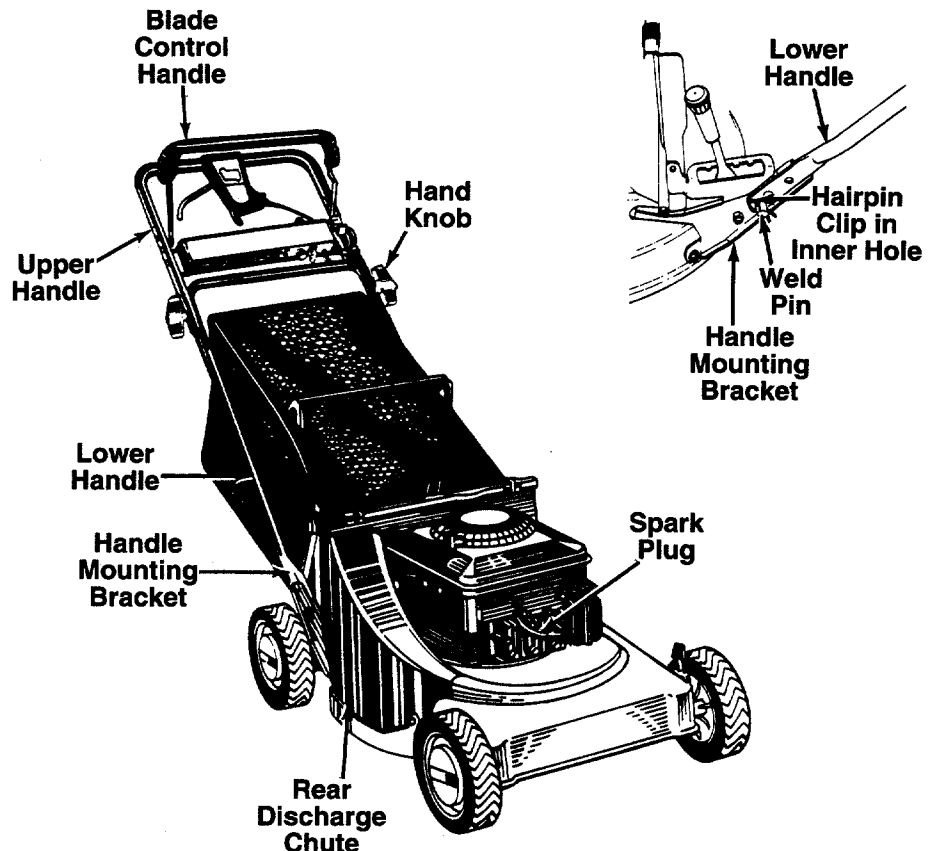

FIGURE 1.

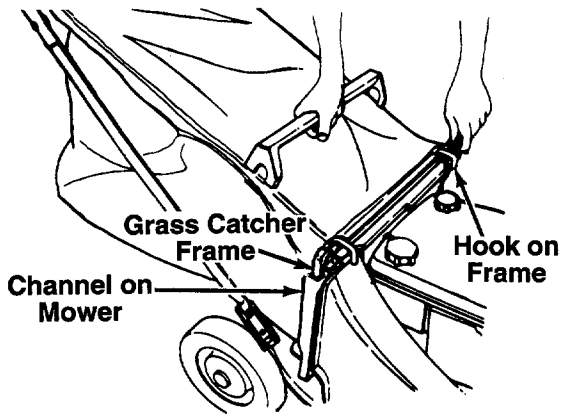

FIGURE 2.

TO ATTACH BAG TO MOWER

1. Hold the chute door on the catcher panel open as shown in figure 2.
2. Slide the frame of the grass catcher down into the channels on each side of the mower. The hooks on the frame go over the panel on the discharge chute. See figure 2.

To remove the grass catcher, lift the grass catcher straight up.

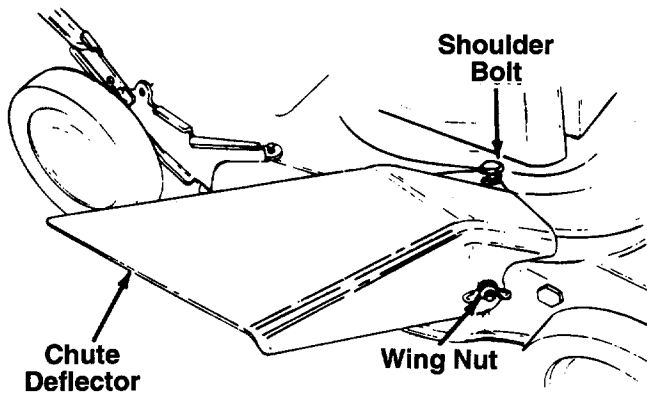

FIGURE 3.

TO CONVERT MOWER TO SIDE DISCHARGE

To convert your mower to a side discharge unit, proceed as follows.

1. Remove the rear discharge chute assembly by removing two wing nuts. Lift up on the two bottom corners of the discharge chute assembly, and slide it off the deck.
2. Attach the side chute deflector by first placing it over the rear bolt in the side of the deck. Then slide the notch in the top of the deflector around the shoulder bolt on top of the deck. Slide the notch in the side of the deflector around the front bolt in the side of the deck. See figure 3.

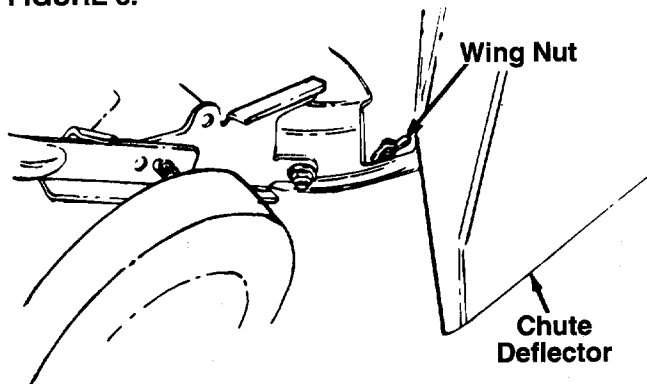

FIGURE 4.

3. Secure the front of the chute deflector to the bolt on the side of the deck with one wing nut. See figure 3. Secure the back of the chute deflector in the same manner. See figure 4.

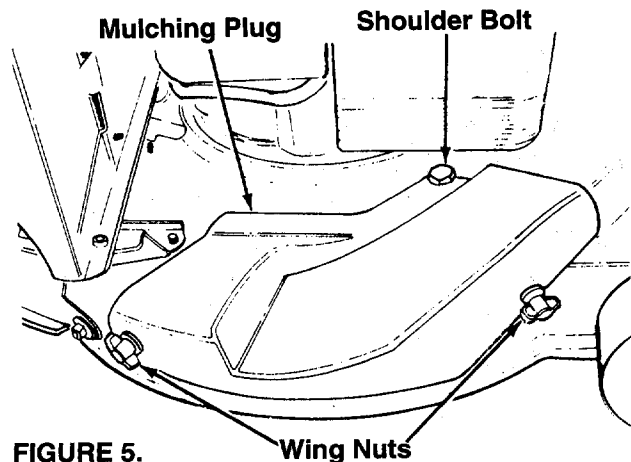

FIGURE 5.

TO CONVERT MOWER TO A MULCHER

To use your mower as a mulcher, proceed as follows.

1. Remove either the rear discharge chute assembly or the side chute deflector from the mower as instructed previously.
2. Attach the mulching plug by first placing it over the rear bolt in the side of the deck. Then slide the notch in the top of the mulching plug around the shoulder bolt on top of the deck. Slide the notch in the side of the mulching plug around the front bolt in side of the deck. Secure using two wing nuts. See figure 5.

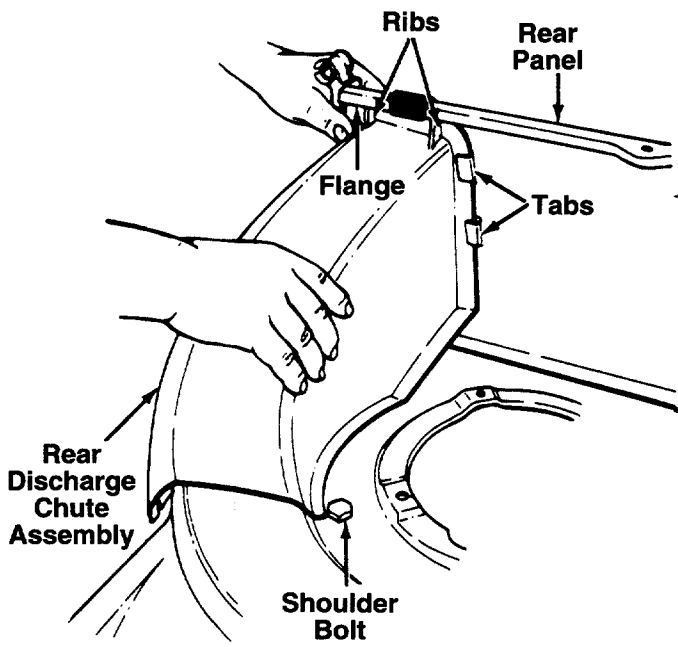

FIGURE 6.

REPLACING THE REAR DISCHARGE CHUTE

To replace the rear discharge chute assembly, proceed as follows.

Slide the ribs on the discharge chute assembly under the flange on rear panel as you insert the side of the discharge chute under the two tabs. See figure 6.

The edge of the discharge chute assembly goes under the shoulder bolt on deck. Push down on the chute assembly, and slide the bottom corner slots over the bolts on side of deck.

Press down on the discharge chute assembly and secure with wing nuts. Make certain wing nuts are seated properly.



WARNING: Never operate your unit without either the side chute deflector, mulching plug or entire rear discharge chute and grass catcher assembly in place.

CONTROLS

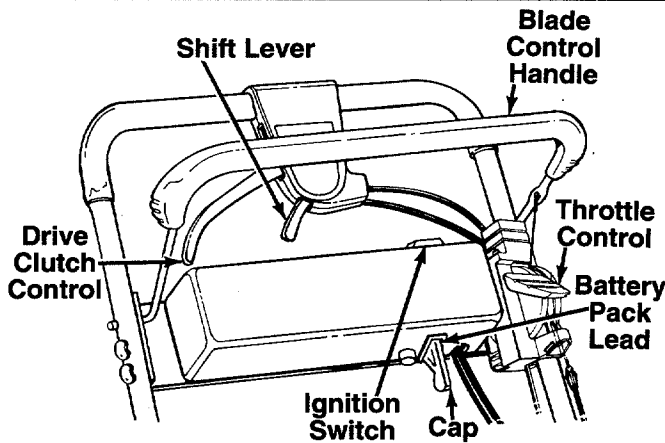

FIGURE 7.

BLADE CONTROL HANDLE



WARNING: This control mechanism is a safety device. Never attempt to bypass its operations.

The blade control handle is located on the upper handle of the mower. See figure 7. The blade control handle must be depressed in order to operate the unit. Release the blade control handle to stop the engine and blade.



WARNING: The blade will be rotating whenever the engine is running.

THROTTLE CONTROL

The throttle control is located on the left side of the upper handle. It is used to regulate the engine speed.



WARNING: The throttle control cannot be used to stop the engine.

IGNITION SWITCH

The ignition switch is located on the left side of the handle panel. It is used for starting only. See figure 7.

DRIVE CLUTCH CONTROL

Squeezing the drive clutch control engages the drive mechanism to the rear wheels. Releasing the clutch control stops the rear wheels from driving. Release the drive clutch control to slow down when negotiating an obstacle, making a turn or stopping. See figure 7.

SHIFT LEVER

The six speed shift lever is located on the drive clutch control housing on the upper handle. See figure 7. This lever is used to select the operating speed of the mower. Release the drive clutch control when changing speeds.

IMPORTANT: Move the shift lever **ONLY** when the engine is running. Shifting the speeds with the engine off can cause damage to the unit.

OPERATION



FIGURE 8.

Keep hands and feet away from the chute area on cutting deck. See figure 8.

The operation of any lawn mower can result in foreign objects being thrown into the eyes, which can result in severe eye damage. Always wear safety glasses or eye shields. We recommend wide vision safety mask for over spectacles or standard safety glasses.



NOTE: For best results raise the cutting position until it is determined which height is best for your lawn. See cutting height adjustment section.

GAS AND OIL FILL-UP

Service the engine with gasoline and oil as instructed in the separate engine manual packed with your mower. Read instructions carefully.



WARNING: Never fill fuel tank indoors, with engine running or until the engine has been allowed to cool for at least two minutes after running.

BEFORE STARTING



WARNING: The battery contains corrosive fluid and toxic material—HANDLE WITH CARE. Keep away from children. Do not puncture, disassemble, mutilate or incinerate. Explosive gases could be vented during charging or discharging. Use in a well-ventilated area, away from sources of ignition.

1. **Charging Instructions:** Charge battery for 16 hours before initial use. **DO NOT CHARGE LONGER THAN 20 HOURS.**

IMPORTANT: Use only the battery charger supplied with this mower.

To charge the battery, first remove the protective cap from the end of the battery pack lead. Always plug charger lead into battery pack lead before inserting battery charger plug into 120 volt standard household outlet.

After charging, disconnect battery charger plug from household outlet first, then disconnect charger lead from battery pack lead.



WARNING: Do not remove the battery pack from the handle panel for any reason other than replacement. When replacing the battery pack, refer to instructions in Maintenance section.

2. Before each use, check for proper drive clutch operation by performing the following before starting the engine:

With the drive clutch control released, push mower forward. It should move freely. Pull mower backward. It should move with only a small amount of resistance.

If it does not and the rear wheels tend to lock up, the clutch may not be releasing completely. Do not start the engine until corrections have been made. Check the control cable for severe bend, kinks and binding, or grass build-up around the belt. Correct and adjust as required. Refer to instructions under "Drive Clutch Control Adjustment" in Adjustment Section for loosening the drive belt.

3. Attach spark plug wire to spark plug. Make certain the metal loop on the end of the spark plug wire (inside the rubber boot) is fastened securely over the metal tip on the spark plug. See figure 9.

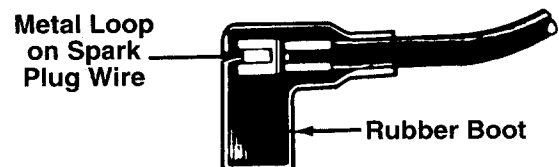

FIGURE 9.

TO START ENGINE AND ENGAGE BLADE

IMPORTANT: Move the shift lever only when the engine is running. Shifting the speeds with the engine off can cause damage to the unit. Disengage the drive clutch control when shifting speeds.



WARNING: When starting the unit for the first time, place mower in first speed (slow) position. Face the mower against a solid object such as a wall, fence, etc. Start the unit, and if it shows any signs of motion with the drive clutch control disengaged, shut the engine off immediately. Make certain the drive clutch control is adjusted so the drive belt is as loose as possible. Refer to the Adjustment Section.

1. Move the throttle control lever to all the way forward.
2. Prime engine as instructed in the separate engine manual packed with your unit.
3. Standing behind the unit, depress the blade control handle and hold it against the upper handle. Make certain drive clutch control handle is released. See figure 10.
4. Turn the ignition key to the right to start the engine. Release the key after engine starts.
5. After engine starts, move throttle control to FAST or desired engine speed.



WARNING: Do not remove the battery pack from the handle panel for any reason other than replacement. When replacing the battery pack, refer to instructions in Maintenance section.

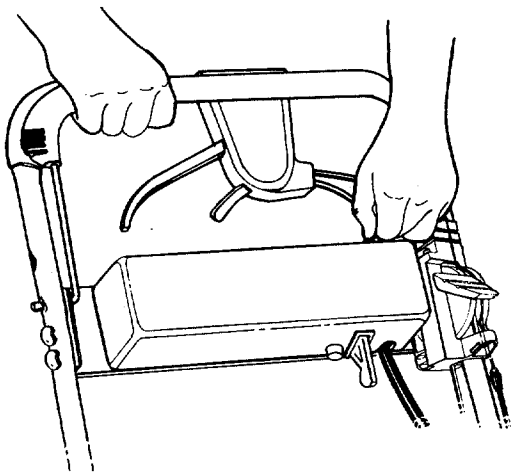

FIGURE 10.

IMPORTANT: The engine on your unit is provided with an auxiliary recoil starter system. To start the engine using the auxiliary starter system, proceed as follows.

- A. Depress the blade control handle, and hold it against the upper handle.
- B. Grasp the recoil starter handle, slowly pull the rope out from the engine about two feet and hold rope in this position.
- C. Step behind the handle into the operating position. With the blade control handle still depressed, pull recoil starter handle using a quick, firm motion. Return rope slowly to the engine. Repeat until engine starts.

NOTE: If any problems are encountered, refer to the *Trouble Shooting Guide* on page 13.



WARNING: Never operate your unit without either the side chute deflector or entire rear discharge chute and grass catcher assembly in place.

TO STOP ENGINE AND BLADE

1. Move throttle control lever to SLOW position.
2. Release the blade control handle to stop the engine and blade.



WARNING: The blade continues to rotate for a few seconds after the engine is shut off.

3. Disconnect the spark plug wire and ground it against the engine to prevent accidental starting while equipment is unattended.

USING YOUR ROTARY MOWER

Be sure that lawn is clear of stones, sticks, wire, or other objects which could damage lawn mower or engine. Such objects could be accidentally thrown by the mower in any direction and cause serious personal injury to the operator and others.

For the best results, do not cut wet grass because it tends to stick to the underside of the mower, preventing proper discharge of grass clippings, and could cause you to slip and fall. New grass, thick grass or wet grass may require a narrower cut. Speed of the mower should be adjusted to the condition of the lawn.

When using the side discharge mower, the best mowing pattern is one that allows the clippings to discharge towards the uncut part of the lawn. This permits recutting of the clippings to further pulverize them. When cutting high weeds, discharge towards cut portion, then recut at right angles to first direction.

For a healthier lawn, always cut off one-third or less of the total length of the grass. Lawn should be cut in the fall as long as there is growth.

This mower is designed to be operated at full throttle to give you the best cut and do the most effective job of bagging the cut grass.



WARNING: If you strike a foreign object, stop the engine. Remove wire from spark plug, thoroughly inspect the mower for any damage, and repair the damage before restarting and operating the mower. Extensive vibration of the mower during operation is an indication of damage. The unit should be promptly inspected and repaired.

USING THE MULCHER

For effective mulching, do not cut wet grass because it tends to stick to the underside of the deck, preventing proper mulching of grass clippings. New or thick grass may require a narrower cut. The ground speed should be adjusted to the condition of the lawn. If mowing has been delayed and the grass has been allowed to grow in excess of 4", mulching is not recommended. Mow using the grass bag to reduce the grass height to 3-1/4" maximum before mulching. Never cut more than one-third off the total length of the grass at any one cutting.

ADJUSTMENTS



WARNING: Do not at any time make any adjustment to lawn mower without first stopping engine and disconnecting spark plug wire.

CUTTING HEIGHT ADJUSTMENT

The height adjustment handles for the wheels are located on the left side of the deck. The handles may be placed in one of nine cutting height positions. See figure 11.

For rough or uneven lawns, move the height adjustment handle to a position which will give a higher cutting height. Both front and rear handles must be placed in the same relative position.

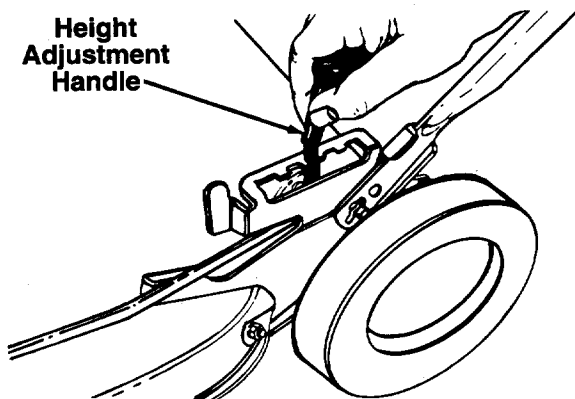

FIGURE 11.

HANDLE HEIGHT ADJUSTMENT

Your mower is shipped with the handle ready to assemble in the higher height position. To lower the handle height, proceed as follows.

1. Remove the upper handle by removing the hand knobs and carriage bolts. Lay the upper handle out of the way, being careful not to bend or kink the cables.
2. Remove the hairpin clips from the weld pins on the handle brackets. Press outward on the legs of the lower handle, and remove it from the mower.
3. Turn the lower handle around so the flat on the bottom is facing upward as shown in figure 12. Reassemble, placing the bottom holes in the handle over the weld pins in the handle mounting bracket.
4. Reassemble the upper handle.
5. Place the hairpin clips in the inner holes in the weld pins.

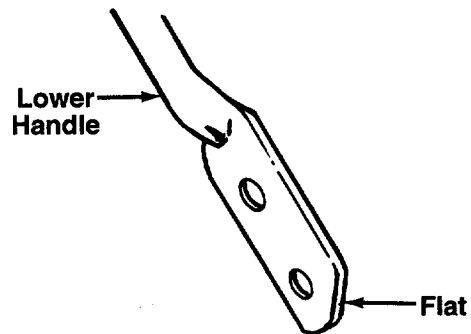

FIGURE 12.

DRIVE CLUTCH CONTROL ADJUSTMENT

Use the adjustment wheel located on the underside of the clutch control housing to tighten the drive belt if mower does not self-propel with the drive clutch control engaged, or if drive belt is slipping (unit hesitates while engine maintains the same speed). See figure 13.

In addition, the adjustment wheel may also be used to determine the position in which the drive clutch control is engaged. If it is more comfortable to have the drive engaged with the lever further away from the handle, tighten the drive belt.

Make certain to retest the unit for neutral as instructed in the Operation Section. Move the adjustment wheel in the opposite direction to loosen the drive belt if necessary.

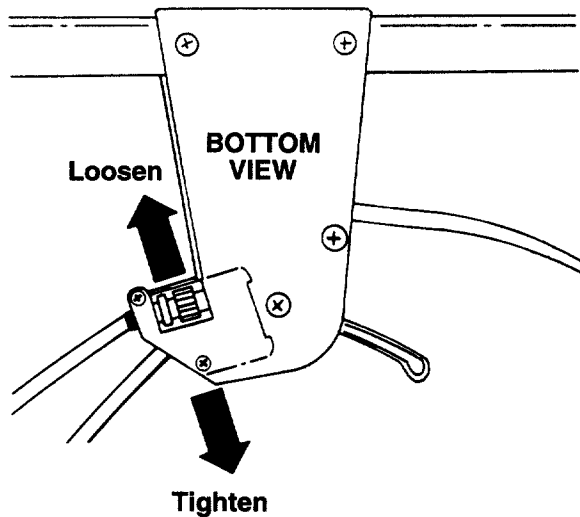

FIGURE 13.

THROTTLE CONTROL ADJUSTMENT

If the throttle control requires adjustment or if it has been replaced, adjust the throttle control as follows.

1. Remove the screw shown in figure 14. Remove the cable clamp from the cable.
2. Push the throttle control lever on the handle all the way forward as far as it will go, then back it off one "click". Make certain the throttle control lever remains in this position.
3. Push the control lever on the engine as far toward the rear of the engine as it will go. Secure the cable in this position with the cable clamp and screw.

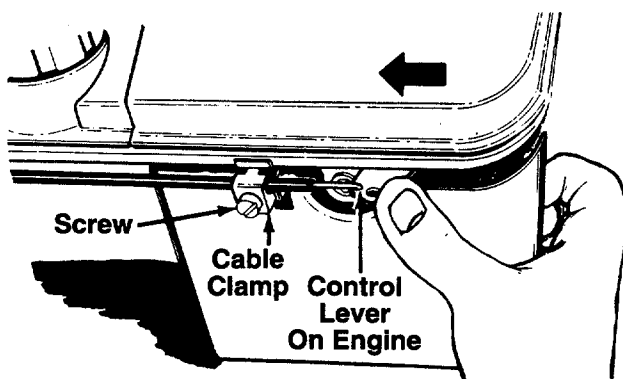

FIGURE 14.

SIX SPEED SHIFT CABLE ADJUSTMENT

Periodic adjustment of the six speed shift cable may be required due to normal stretch and wear on the cable. Adjustment is needed if all six speeds cannot be obtained.

The adjustable cable bracket is located on the left side of the mower, beside the engine. To adjust, place shift lever (at handle) in sixth speed position. Loosen the hex nut which secures the adjustable cable bracket. See figure 15. Pull backward on the bracket (toward the rear of the mower). Retighten the hex nut. Test the speeds on the mower (engine must be running).

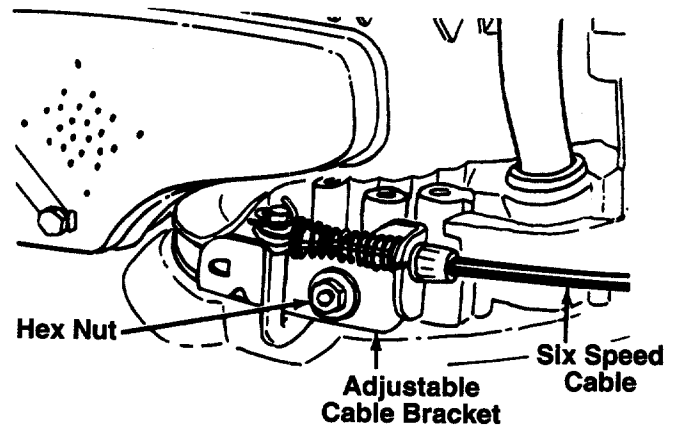

FIGURE 15.

CARBURETOR ADJUSTMENTS



WARNING: If any adjustments are made to the engine while the engine is running (e.g. carburetor), keep clear of all moving parts. Be careful of heated surfaces and muffler.

Minor carburetor adjustment may be required to compensate for differences in fuel, temperature, altitude and load. Refer to the separate engine manual packed with your mower for carburetor adjustment information.

NOTE: A dirty air cleaner will cause an engine to run rough. Be certain air cleaner is clean and attached to the carburetor before adjusting carburetor.

LUBRICATION



WARNING: Always stop engine and disconnect spark plug wire before cleaning, lubricating or doing any kind of work on lawn mower.

Blade Control—Lubricate the pivot points on the blade control handle and the brake cable at least once a season with light oil. See figure 16. The blade control must operate freely in both directions.

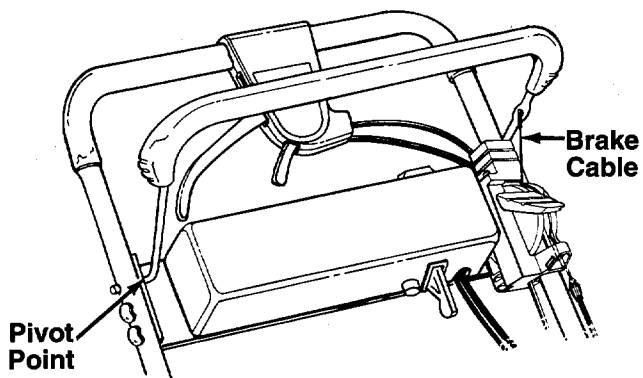

FIGURE 16.

Wheels—Lubricate the wheel bearings at least once a season with light oil. Also, if the wheels are removed for any reason, lubricate the surface of the axle bolt and the inner surface of the wheel with light oil. A 4 oz. plastic bottle of light oil lubricant is available. Order part number 737-0170. Engine oil may also be used.

Engine—Follow engine manual for lubrication instructions.

Transmission—The transmission is pre-lubricated and sealed at the factory. It does not require checking. If disassembled for any reason, fill with 2 ounces of Alvania grease, part number 737-0168.

MAINTENANCE



WARNING: Be sure to disconnect and ground the spark plug wire before performing any repairs or maintenance.

NOTE: When tipping the unit, empty the fuel tank and keep engine spark plug side up.

TROUBLE SHOOTING

Refer to page 13 of this manual for trouble shooting information.

CUTTING BLADE

When removing the cutting blade for sharpening or replacement, protect hands by using heavy gloves or a rag to grasp the cutting blade. Remove the bolt and bell washer which hold the blade and adapter to the engine crankshaft. Remove the blade and adapter from the crankshaft.

If the blade or blade adapter needs replacing, remove the two small bolts, lock washers and nuts which hold the blade to the adapter.



WARNING: Periodically inspect the blade adapter for cracks, especially if you strike a foreign object. Replace when necessary.

When sharpening the blade, follow the original angle of grind as a guide. It is extremely important that each cutting edge receives an equal amount of grinding to prevent an unbalanced blade. An unbalanced blade will cause excessive vibration when rotating at high speeds, may cause damage to the mower and could break, causing personal injury.

It is recommended that the blade always be removed from the adapter for the best test of balance. The blade can be tested by balancing it on a round shaft screwdriver. Remove metal from the heavy side until it balances evenly.

Before reassembling the blade and the blade adapter to the unit, lubricate the engine crankshaft and the inner surface of the blade adapter with light oil. Lubricating the bolt holes, bolts and inner surface of the nuts with light oil is also recommended. A 4 oz. plastic bottle of light oil lubricant is available. Order part number 737-0170. Engine oil may also be used.

When replacing the blade, be sure to install the blade with the side of the blade marked "Bottom" (or with part number) facing the ground when the mower is in the operating position.

Blade Mounting Torque

Center Bolt: 450 in. lb. min., 600 in. lb. max.

Blade Adapter Bolt: 200 in. lb. min., 300 in. lb. max.

To insure safe operation of your unit, all nuts and bolts must be checked periodically for correct tightness.

DECK

The underside of the mower deck should be cleaned after each use to prevent a buildup of grass clippings, leaves, dirt or other matter. If this debris is allowed to accumulate, it will invite rust and corrosion, and may cause an uneven discharge of grass clippings at the next cutting.

The deck may be cleaned by tilting the mower and scraping clean with a suitable tool (make certain the spark plug wire is disconnected).

ENGINE

Refer to the separate engine manual for engine maintenance instructions.

Maintain **engine oil** as instructed in the separate engine manual packed with your unit. Read and follow instructions carefully.

Service **air cleaner** every 25 hours under normal conditions. Clean every few hours under extremely dusty conditions. Poor engine performance and flooding usually indicates that the air cleaner should be serviced. To service the air cleaner, refer to the separate engine manual packed with your unit.

The **spark plug** should be cleaned and the gap reset once a season. Spark plug replacement is recommended at the start of each mowing season; check engine manual for correct plug type and gap specifications.

Clean the engine regularly with a cloth or brush. Keep the cooling system (blower housing area) clean to permit proper air circulation which is essential to engine performance and life. Be certain to remove all grass, dirt and combustible debris from muffler area.

BATTERY PACK REPLACEMENT

Remove the battery pack from the handle panel for replacement only. Do not separate the batteries for any reason. Dispose of batteries properly.



WARNING: Batteries contain sulfuric acid which may cause burns. Do not short circuit or mutilate in any way. Do not put batteries in fire. They may burst or release toxic materials.

When replacing battery pack in handle panel, battery pack must be positioned with the positive terminal to the right hand side and the negative terminal to the left hand side of panel. See figure 17. Replacing the battery pack incorrectly will cause serious damage.

The positive lead on the wire harness has the smaller connector. Connect the positive lead to the positive side of the battery pack, then connect the negative side.

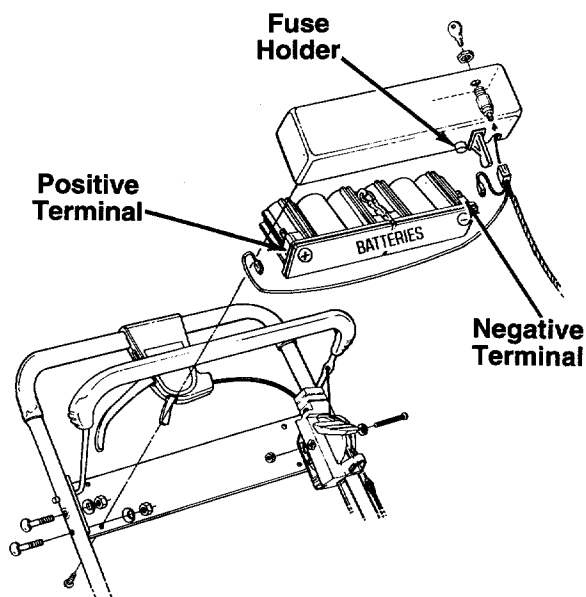

FIGURE 17.

IN-LINE FUSE

The unit is equipped with an in-line fuse. If unit fails to start, check the fuse inside the battery cover by turning the end of the fuse holder and removing from the battery cover. See figure 17. Replace with standard automotive 7-1/2 amp fuse.

STORAGE OF THE BATTERY

The battery must be stored with a full charge. A discharged battery will freeze.

IMPORTANT: All batteries discharge during storage. Recharge battery every two months and before returning to service. Refer to charging instructions in Operation section.

BELT REMOVAL AND REPLACEMENT

1. Disconnect the spark plug wire and ground it against the engine.
2. Drain the fuel tank or place a piece of plastic beneath the cap to prevent gasoline leakage.
3. Remove the grass bag, rear discharge chute assembly and catcher panel.
4. Remove the transmission belt cover by removing three bolts. See figure 18.
5. Tip the mower on its side, and block securely.

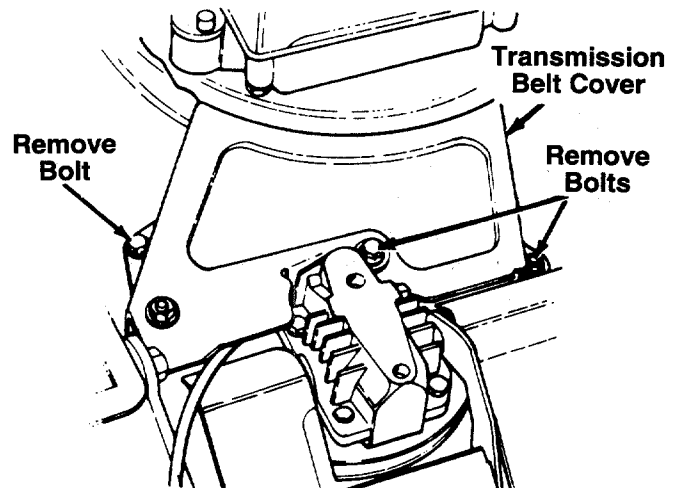

FIGURE 18.

6. Remove the inside belt guard by removing two self-tapping screws. A 3/8" wrench is required. See figure 19.

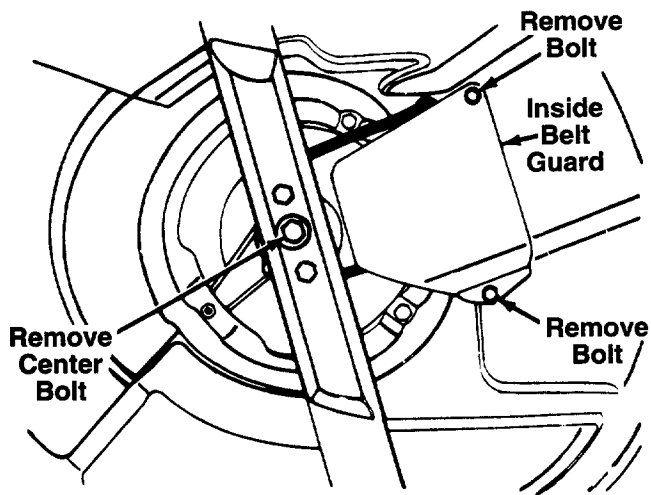

FIGURE 19.

7. Loosen (do not remove) the bolt which secures the idler pulley so you can remove the belt from between the idler pulley and the belt guard on the idler pulley bracket. See figure 20.
8. Remove the belt from the transmission pulley by pulling it underneath the pulley.
9. Remove the belt from around the blade.

NOTE: Before reassembling, it is suggested that you remove the idler pulley from the idler bracket, and clean and re-grease the needle bearing inside the pulley using an all-purpose grease. When reassembling, cupped side of washer must be against the idler bracket.

10. Reassemble new belt, following instructions in reverse order. Belt must be inside the belt keeper which is part of the pulley half (ref. 171 on page 14).

NOTE: When reassembling the transmission belt cover, be certain the belt guard on the transmission cover is approximately 1/8" away from the belt (see ref. 24 on page 17). Make certain to tighten all nuts and bolts securely. If plastic was placed under the gas cap, be certain to remove it.

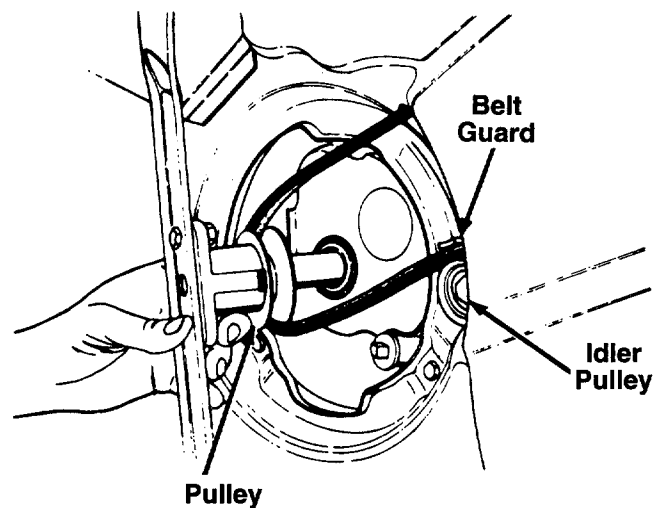

FIGURE 20.

OFF-SEASON STORAGE

The following steps should be taken to prepare lawn mower for storage.

1. Clean and lubricate mower thoroughly as described in the lubrication instructions.
2. Refer to engine manual for correct engine storage instructions.
3. Coat mower's cutting blade with chassis grease to prevent rusting.
4. Follow battery storage instructions on page 11.
5. Store mower in a dry, clean area. Do not store next to corrosive materials, such as fertilizer.

NOTE: When storing any type of power equipment in an unventilated or metal storage shed, care should be taken to rustproof the equipment. Using a light oil or silicone, coat the equipment, especially cables and all moving parts.

TROUBLE SHOOTING GUIDE

Trouble	Possible Cause(s)	Corrective Action
Engine fails to start	<ol style="list-style-type: none"> 1. Blade control handle disengaged. 2. Spark plug wire disconnected. 3. Discharged battery. 4. Throttle control lever not in START position. 5. Fuel tank empty, or stale fuel. 6. Blocked fuel line. 7. Faulty spark plug. 8. Engine flooded. 	<ol style="list-style-type: none"> 1. Engage blade control handle. 2. Connect wire to spark plug. 3. Charge battery or use auxiliary recoil starter as instructed in Operation section. 4. Move throttle lever to START position. 5. Fill tank with clean, fresh gasoline. 6. Clean fuel line. 7. Clean, adjust gap or replace. 8. Remove spark plug, dry the plug, and crank engine with plug removed and throttle in off position. Replace spark plug, connect wire and resume starting procedures.
Engine runs erratic	<ol style="list-style-type: none"> 1. Unit running in START position. 2. Spark plug wire loose. 3. Blocked fuel line or stale fuel. 4. Vent in gas cap plugged. 5. Water or dirt in fuel system. 6. Dirty air cleaner. 7. Carburetor out of adjustment. 	<ol style="list-style-type: none"> 1. Move throttle lever to FAST position. 2. Connect and tighten spark plug wire. 3. Clean fuel line; fill tank with clean, fresh gasoline. 4. Clear vent. 5. Drain fuel tank. Refill with fresh fuel. 6. Clean air cleaner. † 7. Adjust carburetor. †
Engine overheats	<ol style="list-style-type: none"> 1. Engine oil level low. 2. Air flow restricted. 3. Carburetor not adjusted properly. 	<ol style="list-style-type: none"> 1. Fill crankcase with proper oil. 2. Remove blower housing and clean. † 3. Adjust carburetor. †
Occasional skip (hesitates) at high speed	<ol style="list-style-type: none"> 1. Spark plug gap too close. 2. Carburetor idle mixture adjustment improperly set. 	<ol style="list-style-type: none"> 1. Adjust gap to .030". 2. Adjust carburetor. †
Idles poorly	<ol style="list-style-type: none"> 1. Spark plug fouled, faulty or gap too wide. 2. Carburetor improperly adjusted. 3. Dirty air cleaner. 	<ol style="list-style-type: none"> 1. Reset gap to .030" or replace spark plug. 2. Adjust carburetor. † 3. Clean air cleaner. †
Excessive vibration	<ol style="list-style-type: none"> 1. Cutting blade loose or unbalanced. 2. Bent cutting blade. 	<ol style="list-style-type: none"> 1. Tighten blade and adapter. Balance blade. 2. Replace blade.
Mower will not discharge grass	<ol style="list-style-type: none"> 1. Engine speed too low. 2. Wet grass. 3. Excessively high grass. 	<ol style="list-style-type: none"> 1. Set throttle between 3/4 and full throttle. 2. Do not mow when grass is wet; wait until later to cut. 3. Mow once at a high cutting height, then mow again at desired height or make a narrower cutting swath (1/2 width).
Uneven cut	Dull blade.	Sharpen or replace blade.

†Refer to separate engine manual packed with your unit.

Note: For repairs beyond the minor adjustments listed above, contact your local authorized service dealer.

Model 123E898E

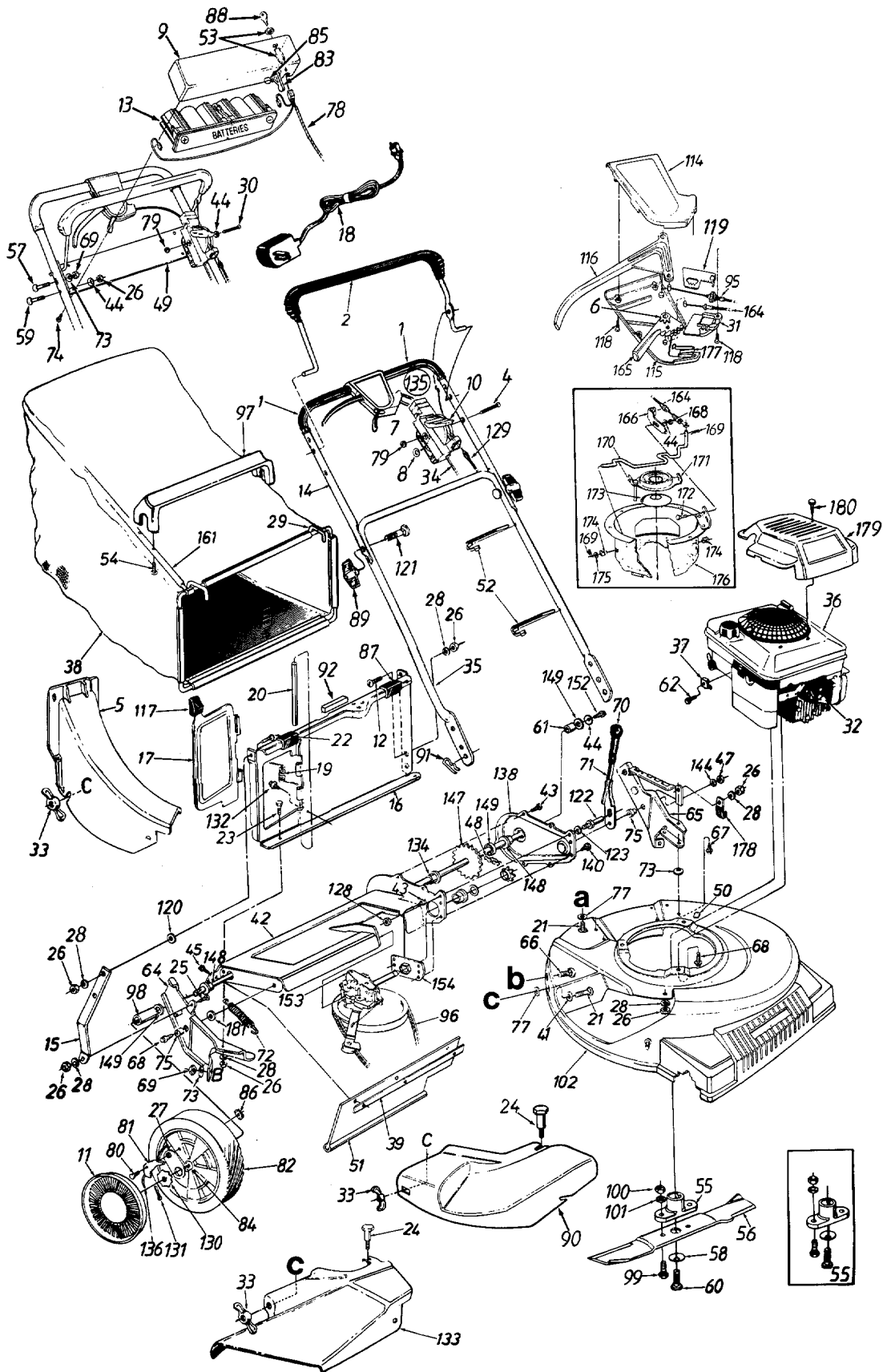

Model 123E898E

PARTS LIST FOR MODEL 123E898E ROTARY MOWER

REF. NO.	PART NO.	CODE	DESCRIPTION	REF. NO.	PART NO.	CODE	DESCRIPTION
1	720-0225		Grip (2 Req'd.—Optional)	60	710-0757		Hex Bolt 7/16-20 x 1.5"
2	647-0004		Control Handle	61	748-0190		Spacer .513" I.D.
4	710-0605		Oval C-Sunk Scr.	62	710-1237		Hex Wash. Hd. Scr. #10-32 x .62" Lg.
5	731-1023		Rear Discharge Chute Ass'y.	63	736-0119		L-Wash. 5/16" I.D.*
6	713-0397		3 Tooth Rack Gear Insert	64	16136B	N	R.H. Handle Wheel Brkt. Ass'y.
7	746-0875		Throttle Body	65	16137B		L.H. Handle Wheel Brkt. Ass'y.
8	736-0501		Spr. Wash. .66" I.D.	66	710-0260		Carriage Bolt 5/16-18 x .62**
9	710-0891A		Battery Tray	67	710-0603		Hex B-Tap Scr. 5/16-18
10	746-0876		Throttle Lever	68	710-0654A		Hex TT-Tap Scr. 3/8-16
11	731-0982A		Hub Cap (Beige)	69	712-0267		Hex Nut 5/16-18 Thd.*
	731-0981A		Hub Cap (Gray)	70	720-0223		Grip
12	710-0946		Truss Mach. Scr. 1/4-20 x .62" Lg.	71	732-0606		Height Adj. Lever
13	725-1276		Battery Pack—12 Volt	72	732-0481		Extension Spring 3.80" Lg.
14	749-0439B		Upper Handle	73	736-0242		Bell-Wash. 5/16" I.D.
15	16129A		Panel Support Brkt.	74	710-0969		Truss Mach. Tap Scr. 1" Lg.
16	16862A		Rear Catcher Panel Ass'y.	75	750-0624		Shld. Spacer .5" Dia.
17	17095A		Rear Discharge Door	77	726-0233		Bolt Retainer 1/4 x .50" O.D.
18	725-0727		Battery Charger	79	712-0324		Hex L-Nut 1/4-20 Thd.
19	732-0483A		Torsion Spring	78	725-1442		Wire Harness
20	747-0514		Pivot Pin	80	738-0137		Shld. Scr. .342" Dia. x .268
21	710-0134		Carriage Bolt 1/4-20 x .62**	81	748-0188B		Pawl
22	710-0255		Truss Mach. Scr. 1/4-20 x .75" Lg.	82	734-1514B		Wheel Ass'y. Comp. (Beige)
23	710-0289		Hex Bolt 1/4-20 x .5" Lg.		734-1510B		Wheel Ass'y. Comp. (Gray)
24	738-0704		Shoulder Bolt Special	83	725-1206		Plug
25	710-0258		Hex Bolt 1/4-20 x .62" Lg.	84	741-0486B		Sleeve Bearing 1/2" I.D.
26	712-0287		Hex Nut 1/4-20 Thd.*	85	725-1428		Fuse Holder
27	16855		Pawl Plate		725-0298		Fuse 7-1/2 Amp (Not Shown)
28	736-0329		L-Wash. 1/4" I.D.*	86	712-0189		Flat Nut 1/4-20 Thd.
29	747-0705		Front Grass Catcher Frame	87	731-0880		Panel Clip
30	710-0501		Hex Bolt 1/4-20 x 2" Lg.	88	725-0201		Ignition Key
31	731-0906		S.P. Control Cover	89	720-0276		Hand Knob
32	735-0639		Spark Plug Insulator	90	731-1343		Mulching Plug
33	712-0397		Wing Nut	91	714-0104		Hairpin Clip
34	746-0674		Throttle Cable 61"	92	722-0139		Foam Strip 1/4" x 1" Lg.
35	749-0907	N	Lower Handle	95	746-0710A		S.P. Cable—50" Lg.
36	—		Engine	96	754-0343		"V"—Belt
37	751-0568		Casing Clamp	97	731-0801		Bag Handle
38	764-0257		Grass Bag	98	711-0313		Sleeve .526" I.D.
39	14835		Retaining Strip	99	710-1055		Hex Bolt 3/8-24 x 1.0" Lg.
41	736-0204		FI-Wash. .344" I.D. x .62"	100	712-0241		Hex Nut 3/8-24 Thd.
42	17055B		Chain—Axle Ass'y.	101	736-0169		L-Wash. 3/8" I.D.
43	710-0352		Hex B-Tap Scr. 1/4" x .38"	102	17051B	N	21" Deck Ass'y.
44	736-0270		Bell-Wash. 1/4" I.D.	114	731-0904		Self-Propelled Control Cover
45	710-0776A		Hex AB-Tap Scr. 1/4 x .62"	115	731-0905		Self-Propelled Control Cover
47	712-0296		Hex Patch L-Nut 3/8-24 Thd.	116	731-0620		Control Lever
48	713-0353		#48 Chain .500" Pitch x 30 Links	117	720-0190		Door Grip
49	782-9012		Lower Battery Tray	118	710-0841		FI—"C"—Sunk Hd. Tap Scr. #10 x .75" Lg.
50	731-0564		Plug	119	16864		6-Speed Rack Cable Brkt.
51	731-0672A		Rear Flap 3.75" x 17.30" Lg.	120	736-0211		FI-Wash. .285" I.D. x 1.25" O.D.
52	726-0240		Cable Tie	121	710-1174		Curved Hd. Bolt 5/16-18 x 2" Lg.
53	725-0873		Ignition Switch	122	711-0805		Shld. Pin 1.43" Lg.
54	710-1025		Hex AB-Tap Scr. #12 x 1.25" Lg.	123	736-0169		L-Wash. 3/8" I.D.
55	753-0485		Blade Adapter Kit	128	712-0711		Hex Jam Nut 3/8-24 Thd.*
56	742-0721	N	21" Mulching Blade	129	746-0912	N	Control Cable—44"
57	710-0671		Curved Carr. Bolt 5/16-18 x 1.38" Lg.	130	748-0318		Ratchet Wheel 1.62" O.D.
58	736-0453		Bell-Wash. .46" I.D.	131	714-0115		Cotter Pin 1/8" Dia. x 1**
59	710-0111		Carr. Bolt 1/4-20 x 1.25" Lg.	132	710-0429		Hex B-Tap Scr. #10 x .38" Lg.
				133	731-0885		Side Chute Deflector Ass'y.

Model 123E898E

PARTS LIST FOR MODEL 123E898E ROTARY MOWER (CONTINUED)

REF. NO.	PART NO.	CODE	DESCRIPTION	REF. NO.	PART NO.	CODE	DESCRIPTION
134	741-0522		Hex Flange Bearing	165	731-0924		6-Spd. Shift Lever
135	811-00185		Throttle Box Comp. (Incl. Ref. 4, 7, 8, 10, 79)	166	17070		Adjustable Cable Brkt.
136	10622B		Spring—Nylon	168	712-0291		Hex Cent. L-Nut 1/4-20 Thd.
138	17053A		Chain Cover	169	714-0507		Cot-Pin 3/32" Dia. x .75" Lg.
140	710-0599		Hex S-Tap Scr. 1/4-20 x .50"	170	747-0684		Shift Rod
144	736-0300		FI-Wash. .385" I.D. x .87"	171	741-0500		Movable Pulley Half Ass'y.
147	738-0719A		Rear Shaft Ass'y. 21.94" Lg.	172	710-0167		Carr. Bolt 1/4-20 x .5" Lg.
148	741-0324		Hex Flange Brg. .506" I.D.	173	756-0503		Splined Pulley Half
149	736-0160		FI-Wash. .531" I.D. x .930"	174	731-1137		Flanged Bushing
152	710-0751		Hex Bolt 1/4-20 x .62" Lg. (Grade 5)	175	736-0278		FI-Wash. .328" I.D. x .68" O.D.
153	717-0417B		Transmission Comp. (See Breakdown)	176	682-7514	N	Housing Ass'y.
154	16500A		Hex Bearing Cup	177	732-0627		Shift Lever Spring
161	749-0764A		Rear Catcher Frame	178	726-0175		Clamp
164	746-0706		Spd. Control Cable—50" Lg.	179	751B281191	N	Engine Cover (Black)
					751B281302	N	Engine Cover (Gray)
				180	710-1256		Screw #10 x 1.25" Lg.
				181	736-0258		FI-Wash. .383" I.D. x 1" O.D.

*For faster service obtain standard nuts, bolts and washers locally. If these items cannot be obtained locally, order by part number and size as shown on parts list.

CODE: N notates a **new part** (not previously existing).

COLOR: A three digit number is the **color code**. Specify color code if color or finish is important when ordering parts. [i.e., (part no.)-498 for Yellow Finish]

498—Yellow
662—Gray



Specifications subject to change without notice or obligation.

NOTE: The engine is not under warranty by the mower manufacturer. . .If repairs or service is needed on the engine, please contact your nearest authorized engine service outlet. Check the "Yellow Pages" of your telephone book under "Engines—Gasoline."



NOTE: The use of any accessory on this Rotary Mower other than those manufactured by the mower manufacturer is **not** recommended.



WARNING: DO NOT operate the mower without the entire grass catcher or chute deflector in place. **DO NOT** operate the mower without the protective shield on the rear of the deck in place.

NOTE: Under normal usage bag material is subject to wear and should be checked periodically. Be sure any replacement bag complies with the mower manufacturer's recommendations. For replacement bags, use only factory authorized replacement bag.

Model 123E898E

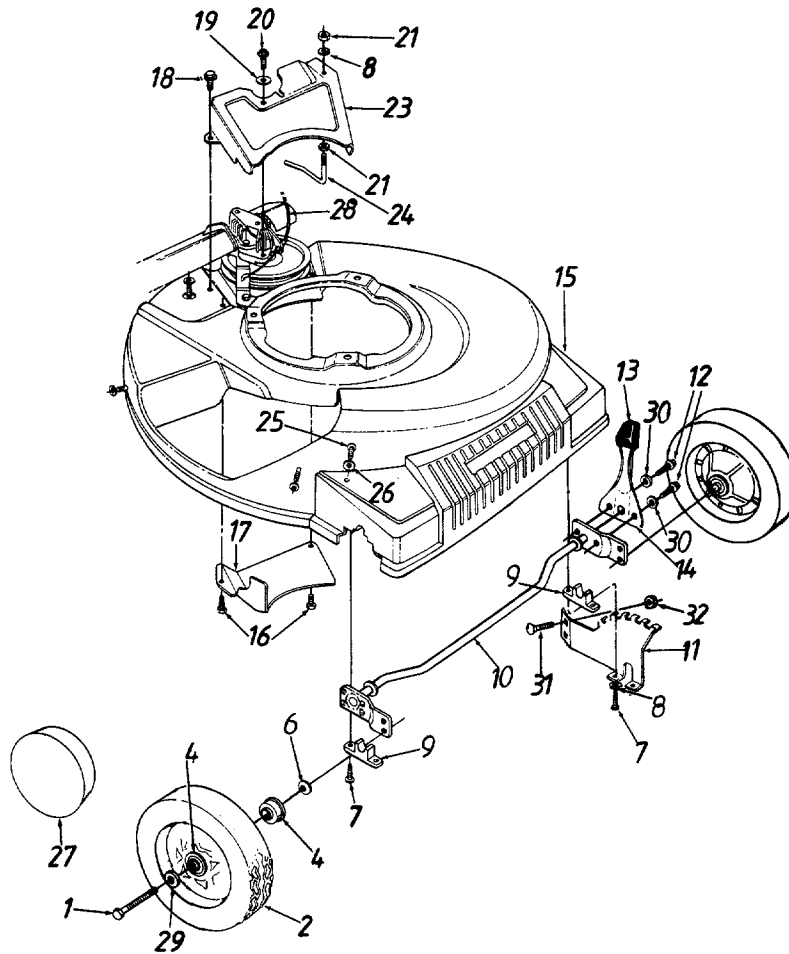

PARTS LIST FOR MODEL 123E898E ROTARY MOWER

REF. NO.	PART NO.	CODE	DESCRIPTION	REF. NO.	PART NO.	CODE	DESCRIPTION
1	738-0102		Front Axle Bolt	17	17065A		Belt Cover
2	734-1517B		Wheel Ass'y. Comp. (Beige)	18	710-0599		Hex Wash. Hd. TT-Scr. 1/4-20
	734-1513B		Wheel Ass'y. Comp. (Gray)	19	736-0270		Bell-Wash. .265" I.D. x .75"
4	741-0484		Flange Ball Brg. .501" I.D.	20	710-0896		Hex Wash. Hd. B-Tap Scr.
6	736-0105		Bell-Wash. .380" I.D. x .88	21	712-0287		Hex Wash. Hd. TT-Scr. 1/4-20 x
7	710-1241		Hex Wash. Hd. Scr. 1/4-20 x	23	17058A		Hex Nut 1/4-20 Thd.*
			1" Lg.	24	747-0549		Transmission Belt Guard
8	736-0329		L-Wash. 1/4" I.D.*	25	710-1242		S.P. Belt Guard
9	741-0492A		Block Bushing	26	736-0242		Torx Truss Hd. Scr. 5/16 x .75"
10	17733		Axle Ass'y.	27	731-0982A		Bell-Wash. .345" I.D. x .88" O.D.
11	782-0516		Height Adj. Bracket		731-0981A		Hub Cap (Beige)
12	710-0653		Hex Wash. Hd. TT-Tap Scr.	28	746-0710A		Hub Cap (Gray)
			1/4-20 x .38" Lg.	29	736-0504		S.P. Cable 50" Lg.
13	720-0190		Knob				Wave Wash. .51" I.D. x .75"
14	732-0639		Spring Lever				O.D.
15	731-1281		Plastic Front End (Black)	30	736-0222		External L-Wash. 1/4" I.D.
	731-1422	N	Plastic Front End (Gray)	31	710-0167		Carr. Bolt 1/4-20 x .5" Lg.
16	710-0352		Hex B-Tap Scr. 1/4" x .38"	32	712-3027		Hex L-Nut 1/4-20 Thd.

Model 123E898E

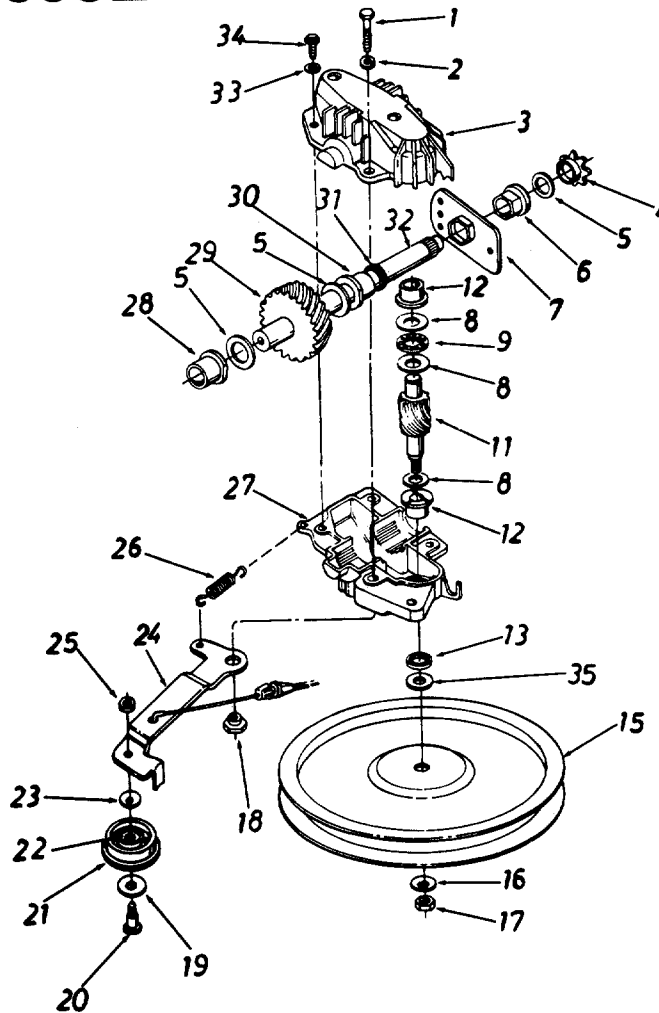

PARTS LIST FOR MODEL 123E898E ROTARY MOWER

REF. NO.	PART NO.	CODE	DESCRIPTION	REF. NO.	PART NO.	CODE	DESCRIPTION
1	710-1062		Hex Bolt 1/4-20 x 1.25" Lg.*	18	738-0440		Shld. Spacer .375" Dia. x .170"†
2	736-0329		L-Wash. 1/4" I.D.*	19	736-0344		FI-Wash. .390" I.D. x 1.0"†
3	717-0418A		Upper Hsg. Half	20	738-0826		Shld. Bolt .375" Dia. x .40"†
4	713-0400		#48 Sprocket 7 Tooth x 1/2 Pitch	21	756-0558		FI-Idler Plastic 1.50" Dia.†
5	736-0336		FI-Wash. 5/8" I.D. x .030	22	741-0556		Needle Brg. .375" x .31"†
6	741-0413		Hex Flange Brg. .631" I.D.	23	736-0270		Bell-Wash. .265" I.D. x .75"†
7	16500A		Hex Bearing Cup	24	17052A		Idler Brk't. Ass'y.†
8	736-0314		Thrust Wash. .382" I.D. x .70" O.D.	25	712-0138		Hex Patch L-Nut 1/4-28 Thd.†
9	741-0479		Thrust Bearing .375" I.D. x .812" O.D.	26	732-0357A		Extension Spring 1.12" Lg.†
11	717-1216		11 Tooth Pinion Shaft	27	717-0419A		Lower Hsg. Half
12	748-0208A		Flange Bearing	28	741-0415		Flange Bearing .566 Dia.
13	721-0212		Oil Seal	29	717-0422A		33 Tooth Helical Gear
15	756-0330A		FI-Pulley 5.06" O.D.†	30	741-0414		Flange Bearing .629 Dia.
16	736-0270		Bell-Wash. .265" I.D. x .75"†	31	721-0213		Oil Seal .625 Dia.
17	712-0351		Hex L-Nut 1/4-28 L.H. Thd.†	32	738-0607A		Gear Sprocket Shaft
				33	736-0722		L-Wash. #10 I.D.
				34	710-0436		Hex B-Tap Scr. #10 x .62"
				35	736-0410		Hex Washer .26" x .88"†
				—	717-0417B		Transmission Comp.

†Not Part of Transmission Complete

USE THIS PAGE AS A GUIDE TO DETERMINE SLOPES WHERE YOU MAY NOT OPERATE SAFELY.

SLOPE GAUGE

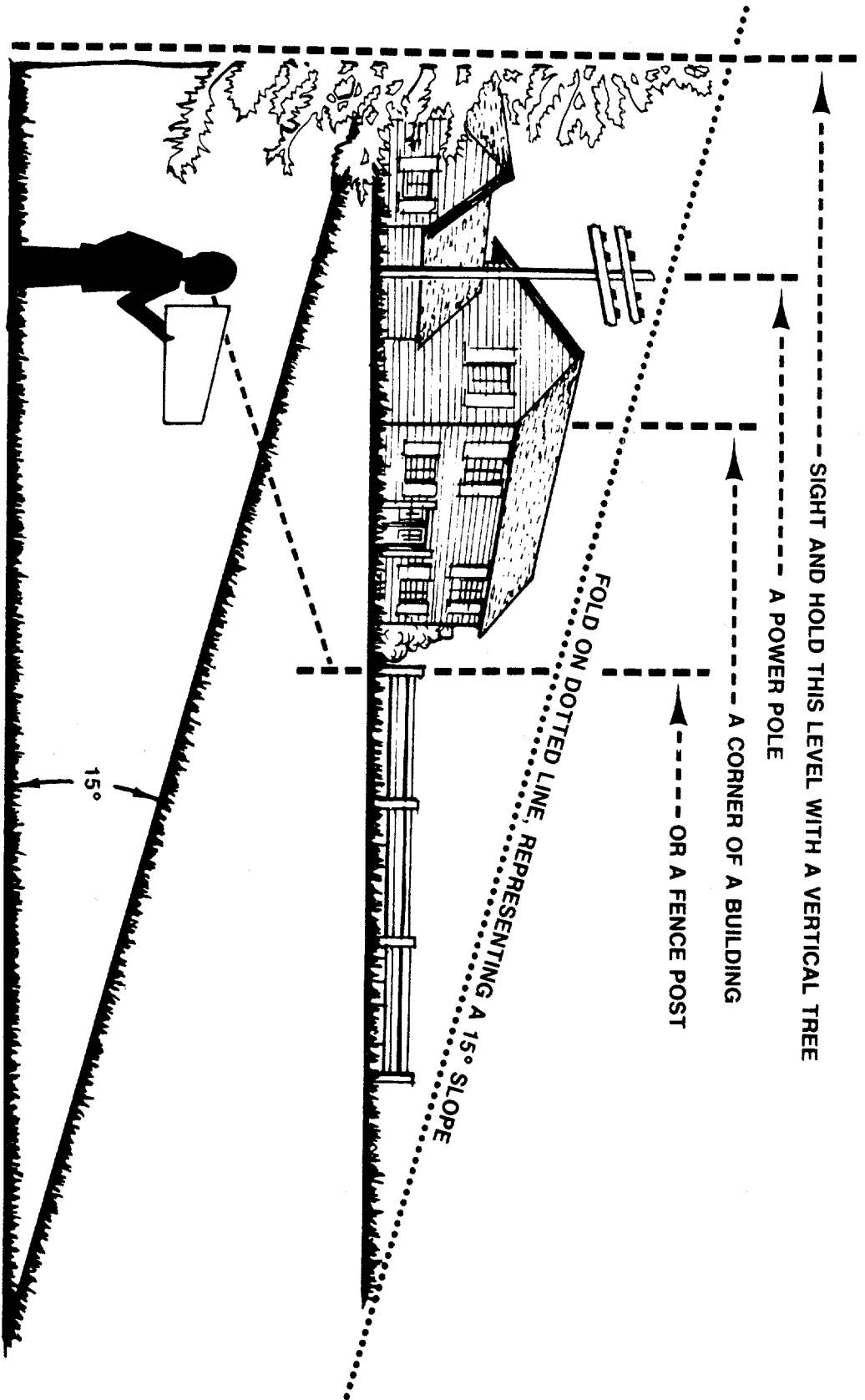

Do not mow on inclines with a slope in excess of 15 degrees (a rise of approximately 2-1/2 feet every 10 feet). A riding mower could overturn and cause serious injury. If operating a walk-behind mower on such a slope, it is extremely difficult to maintain your footing and you could slip, resulting in serious injury.

Operate RIDING mowers up and down slopes, never across the face of slopes.

Cub Cadet

Power Equipment

**LIMITED WARRANTY
TWO-YEAR RESIDENTIAL
ONE-YEAR COMMERCIAL**

Proper maintenance of your Cub Cadet equipment is the owner's responsibility. Follow the instructions in your owner's manual for correct lubricants and maintenance schedule. Your Cub Cadet dealer carries a complete line of quality lubricants and filters for your equipment's engine, transmission, chassis and attachments.

**RIDING MOWERS, LAWN TRACTORS, GARDEN TRACTORS, CUB CADET ATTACHMENTS
AND HOME MAINTENANCE PRODUCTS**

This limited warranty for residential users, covers any defect in materials or workmanship in your Cub Cadet equipment for two years from the date of purchase for the first user purchaser.

We will replace or repair any part or parts without charge through your authorized Cub Cadet dealer.

Batteries have a one-year prorated limited warranty with 100% replacement during the first three months.

V-belts for either the traction drive or any attachments are covered for one year only.

Cub Cadet equipment used commercially is warranted for one year only.

(Commercial use is defined as either having hired operators or used for income producing purpose.)

ITEMS NOT COVERED

The warranty does not cover routine maintenance items such as lubricants, filters (oil, fuel, air and hydraulic), cleaning, tune-ups, brake and/or clutch inspection, adjustments made as part of normal maintenance, blade sharpening, set-up, abuse, accidents and normal wear. It does not cover incidental costs such as transporting your equipment to and from the dealer, telephone charges or renting a product temporarily to replace a warranted product.

There is no other express warranty.

HOW TO OBTAIN SERVICE

Contact your authorized Cub Cadet servicing dealer who sold you your Cub Cadet equipment. If this dealer is not available, see the Consumer Yellow Pages under "lawn mowers" for the name of a dealer near you.

If you need further assistance in finding an authorized Cub Cadet servicing dealer, contact:

Cub Cadet Corporation
Post Office Box 368023
Cleveland, Ohio 44136-9723

HOW DOES STATE LAW APPLY?

This limited warranty gives you specific legal rights, and you may also have other rights which vary from state to state.