

***Cub Cadet***<sup>®</sup>

**Power Equipment**

# Owner's Manual

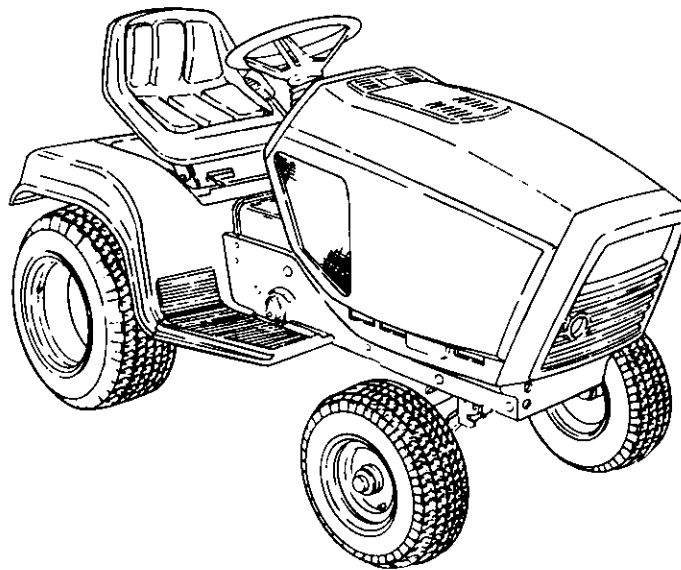

## **GARDEN TRACTOR**

**Model Numbers**

**1863**

**1864**

**Important:**

**Read Safety Rules and Instructions Carefully**

Thank you for purchasing an American-built product

**CUB CADET CORPORATION • P.O. BOX 368023 • CLEVELAND, OHIO 44136-9723**

# **LIMITED WARRANTY**

**TWO-YEAR RESIDENTIAL  
ONE-YEAR COMMERCIAL**

Proper maintenance of your Cub Cadet equipment is the owner's responsibility. Follow the instructions in your owner's manual for correct lubricants and maintenance schedule. Your Cub Cadet dealer carries a complete line of quality lubricants and filters for your equipment's engine, transmission, chassis and attachments.

## **RIDING MOWERS, LAWN TRACTORS, GARDEN TRACTORS, CUB CADET ATTACHMENTS AND HOME MAINTENANCE PRODUCTS**

This limited warranty for residential users, covers any defect in materials or workmanship in your Cub Cadet equipment for two years from the date of purchase for the first user purchaser.

We will replace or repair any part or parts without charge through your authorized Cub Cadet dealer.

Batteries have a one-year prorated limited warranty with 100% replacement during the first three months.

V-belts for either the traction drive or any attachments are covered for one year only.

Cub Cadet equipment used commercially is warranted for one year only.

(Commercial use is defined as either having hired operators or used for income producing purpose.)

## **ITEMS NOT COVERED**

The warranty does not cover routine maintenance items such as lubricants, filters (oil, fuel, air and hydraulic), cleaning, tune-ups, brake and/or clutch inspection, adjustments made as part of normal maintenance, blade sharpening, set-up, abuse, accidents and normal wear. It does not cover incidental costs such as transporting your equipment to and from the dealer, telephone charges or renting a product temporarily to replace a warranted product.

There is no other express warranty.

## **HOW TO OBTAIN SERVICE**

Contact your authorized Cub Cadet servicing dealer who sold you your Cub Cadet equipment. If this dealer is not available, see the Consumer Yellow Pages under "lawn mowers" for the name of a dealer near you.

If you need further assistance in finding an authorized Cub Cadet servicing dealer, contact:

**Cub Cadet Corporation  
Post Office Box 368023  
Cleveland, Ohio 44136**

## **HOW DOES STATE LAW APPLY?**

This limited warranty gives you specific legal rights, and you may also have other rights which vary from state to state.

# CONTENTS

Section	Page	Section	Page
Warranty .....	2	VI Mowing .....	30
Safe Operation Practices .....	3	Optional Equipment	
Product Graphics .....	6	and Accessories .....	31
To The Owner .....	7	Maintenance Chart .....	32
Serial No. Location .....	7	Trouble Shooting .....	33
I Controls .....	8	Lubrication Table .....	35
II Operation .....	14	Lubrication Guide .....	36
III Adjustments .....	18	Specifications .....	40
IV Maintenance .....	23	Slope Gauge .....	41
V Off-Season Storage .....	29	Maintenance Parts Chart .....	43



## WARNING

This unit is equipped with an internal combustion engine and should not be used on or near any unimproved forest-covered, brush-covered or grass-covered land unless the engine's exhaust system is equipped with a spark arrester meeting applicable local or state laws (if any). If a spark arrester is used, it should be maintained in effective working order by the operator.

In the State of California the above is required by law (Section 4442 of the California Public Resources Code). Other states may have similar laws. Federal laws apply on federal lands. A spark arrester muffler is available at your nearest engine authorized service center.

# IMPORTANT

## SAFE OPERATION PRACTICES



THIS SYMBOL POINTS OUT IMPORTANT SAFETY INSTRUCTIONS WHICH, IF NOT FOLLOWED, COULD ENDANGER THE PERSONAL SAFETY AND/OR PROPERTY OF YOURSELF AND OTHERS. READ AND FOLLOW ALL INSTRUCTIONS IN THIS MANUAL BEFORE ATTEMPTING TO OPERATE YOUR UNIT. WHEN YOU SEE THIS SYMBOL –  **HEED ITS WARNING.**



### DANGER:

Your lawn mower was built to be operated according to the rules for safe operation in this manual. As with any type of power equipment, carelessness or error on the part of the operator can result in injury. This lawn mower is capable of amputating hands and feet and throwing objects. Failure to observe the following safety instructions could result in serious injury or death.



### I. GENERAL OPERATION

1. Read, understand and follow all instructions in the manual and on the machine before starting. Keep this manual in a safe place for future and regular reference and for ordering replacement parts.
2. Only allow responsible individuals familiar with the instructions to operate the machine. Know controls and how to stop the machine quickly.
3. Do not put hands or feet under cutting deck or near rotating parts.
4. Clear the area of objects such as rocks, toys, wire, etc. which could be picked up and thrown by the blade. A small object may have been overlooked and could be accidentally thrown by the mower in any direction and cause injury to you or a bystander. To help avoid a thrown objects injury, keep children, animals, bystanders and helpers at least 75 feet from the mower while it is in operation. Always wear safety glasses with

side shields or safety goggles during operation or while performing an adjustment or repair, to protect eyes from foreign objects. Stop the blade(s) when crossing gravel drives, walks or roads.

5. Be sure the area is clear of other people before mowing. Stop machine if anyone enters the area.
6. Never carry passengers.
7. Disengage blade(s) before shifting into reverse and backing up. Always look down and behind before and while backing.
8. Be aware of the mower and attachment discharge direction and do not point it at anyone. Do not operate the mower without either the entire grass catcher or the chute guard in place.
9. Slow down before turning. Operate the machine smoothly. Avoid erratic operation and excessive speed.
10. Never leave a running machine unattended. Always turn off blade(s), place transmission in neutral, set park brake, stop engine and remove key before dismounting.
11. Turn off blade(s) when not mowing.
12. Stop engine and wait until blade(s) comes to a complete stop before (a) removing grass catcher or unclogging chute, or (b) making any repairs, adjusting or removing any grass or debris.
13. Mow only in daylight or good artificial light.
14. Do not operate the machine while under the influence of alcohol or drugs.
15. Watch for traffic when operating near or crossing roadways.
16. Use extra care when loading or unloading the machine into a trailer or truck. This unit should not be driven up or down a ramp onto a trailer or truck under power, because the unit could tip over causing serious personal injury. The unit must be pushed manually on a ramp to load or unload properly.
17. Never make a cutting height adjustment while the engine is running if operator must dismount to do so.
18. Wear sturdy, rough-soled work shoes and close-fitting slacks and shirts. Do not wear loose fitting clothes or jewelry. They can be caught in moving parts. Never operate a unit in bare feet, sandals or sneakers.
19. Check overhead clearance carefully before driving under power lines, wires, bridges or low hanging tree branches, before entering or leaving buildings, or in any other situation where the

operator may be struck or pulled from the unit, which could result in serious injury.

20. Disengage all attachment clutches, thoroughly depress the brake pedal and shift into neutral before attempting to start engine.
21. Your mower is designed to cut normal residential grass of a height no more than 10". Do not attempt to mow through unusually tall, dry grass (e.g. pasture) or piles of dry leaves. Debris may build up on the mower deck or contact the engine exhaust presenting a potential fire hazard.



## **II. SLOPE OPERATION**

Slopes are a major factor related to loss of control and tip-over accidents which can result in severe injury or death. **All slopes require extra caution.** If you cannot back up the slope or if you feel uneasy on it, do not mow it.

For your safety, use the slope gauge included as part of this manual to measure slopes before operating this unit on a sloped or hilly area. If the slope is greater than 15° as shown on the slope gauge, do not operate this unit on that area or serious injury could result.

### **DO:**

Mow up and down slopes, not across.

Remove obstacles such as rocks, limbs, etc.

Watch for holes, ruts or bumps. Uneven terrain could overturn the machine. **Tall grass can hide obstacles.**

Use slow speed. Choose a low enough gear so that you will not have to stop or shift while on the slope. Always keep machine in gear when going down slopes to take advantage of engine braking action.

Follow the manufacturer's recommendations for wheel weights or counterweights to improve stability.

Use extra care with grass catchers or other attachments. These can change the stability of the machine.

Keep all movement on the slopes **slow and gradual**. Do not make sudden changes in speed or direction. Rapid engagement or braking could cause the front of the machine to lift and rapidly flip over backwards which could cause serious injury.

Avoid starting or stopping on a slope. If tires lose traction, disengage the blade(s) and proceed slowly **straight down** the slope.

### **DO NOT:**

**Do not** turn on slopes unless necessary; then, turn slowly and gradually downhill, if possible.

**Do not** mow near drop-offs, ditches or embankments. The mower could suddenly turn over if a wheel is over the edge of a cliff or ditch, or if an edge caves in.

**Do not** mow on wet grass. Reduced traction could cause sliding.

**Do not** try to stabilize the machine by putting your foot on the ground.

**Do not** use grass catcher on steep slopes.



### **III. CHILDREN**

Tragic accidents can occur if the operator is not alert to the presence of children. Children are often attracted to the machine and the mowing activity. **Never** assume that children will remain where you last saw them.

1. Keep children out of the mowing area and in watchful care of an adult other than the operator.
2. Be alert and turn machine off if children enter the area.
3. Before and when backing, look behind and **down** for small children.
4. Never carry children. They may fall off and be seriously injured or interfere with safe machine operation.
5. Never allow children under 14 years old to operate the machine. Children 14 years and over should only operate machine under close parental supervision and proper instruction.
6. Use extra care when approaching blind corners, shrubs, trees or other objects that may obscure your vision of a child or other hazard.
7. Remove key when machine is unattended to prevent unauthorized operation.



### **IV. SERVICE**

1. Use extreme care in handling gasoline and other fuels. They are extremely flammable and the vapors are explosive.

- A. Use only an approved container.
- B. Never remove fuel cap or add fuel with the engine running. Allow engine to cool at least two minutes before refueling.
- C. Replace fuel cap securely and wipe off any spilled fuel before starting the engine as it may cause a fire or explosion.
- D. Extinguish all cigarettes, cigars, pipes and other sources of ignition.

E. Never refuel the machine indoors because fuel vapors will accumulate in the area.



F. Never store the fuel container or machine inside where there is an open flame or spark, such as a gas hot water heater, space heater or furnace.

2. Never run a machine inside a closed area.
3. To reduce fire hazard, keep the machine free of grass, leaves or other debris build-up. Clean up oil or fuel spillage. Allow machine to cool at least 5 minutes before storing.
4. Before cleaning, repairing or inspecting, make certain the blade and all moving parts have stopped. Disconnect the spark plug wire, and keep the wire away from the spark plug to prevent accidental starting.
5. Check the blade and engine mounting bolts at frequent intervals for proper tightness. Also visually inspect blade for damage (e.g., excessive wear, bent, cracked). Replace with blade which meets original equipment specifications.
6. Keep all nuts, bolts and screws tight to be sure the equipment is in safe working condition.
7. Never tamper with safety devices. Check their proper operation regularly. Use all guards as instructed in this manual.
8. After striking a foreign object, stop the engine, remove the wire from the spark plug and thoroughly inspect the mower for any damage. Repair the damage before restarting and operating the mower.
9. Grass catcher components are subject to wear, damage and deteriorate, which could expose moving parts or allow objects to be thrown. For your safety protection, frequently check components and replace with manufacturer's recommended parts when necessary.
10. Mower blades are sharp and can cut. Wrap the blade(s) or wear gloves and use extra caution when servicing blade(s).
11. Check brake operation frequently. Adjust and service as required.
12. Muffler, engine and belt guards become hot during operation and can cause a burn. Allow to cool down before touching.
13. Do not change the engine governor settings or overspeed the engine. Excessive engine speeds are dangerous.
14. Observe proper disposal laws and regulations. Improper disposal of fluids and materials can harm the environment and the ecology.

- A. Prior to disposal, determine the proper method to dispose of waste from your local Environmental Protection Agency. Recycling centers are established to properly dispose of materials in an environmentally safe fashion.
- B. Use proper containers when draining fluids. Do not use food or beverage containers that may mislead someone into drinking from

them. Properly dispose of the containers immediately following the draining of fluids.

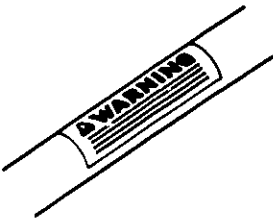
- C. DO NOT pour oil or other fluids into the ground, down a drain or into a stream, pond, lake or other body of water. Observe Environmental Protection Agency regulations when disposing of oil, fuel, coolant, brake fluid, filters, batteries, tires and other harmful waste.

 <p><b>OWNER'S MANUAL</b></p>	 <p><b>SAFETY LABEL</b></p>	 <p><b>WARNING - YOUR RESPONSIBILITY</b></p> <p>Restrict the use of this power machine to persons who read, understand and follow the warnings and instructions in this manual and on the machine.</p>
--	--	---

### PRODUCT GRAPHICS

Keep safety product graphics (decals) clean. Replace any safety graphic that is damaged, destroyed,

missing, painted over or can no longer be read. Replacement safety graphics are available through your dealer.

**BRAKE LOCK**



NOTE: IF THE BRAKE LOCK IS DISENGAGED AND THE OPERATOR LEAVES THE SEAT WHILE THE ENGINE IS RUNNING, THE ENGINE WILL SHUT OFF.

**IGNITION**

OFF - ON-LIGHTS  
ON - START



**SPEED CONTROL LEVER**



**PTO SWITCH**

OFF      PULL OUT      RUN



PTO SWITCH MUST BE IN OFF POSITION BEFORE STARTING UNIT AND BEFORE SHIFTING TRACTOR INTO REVERSE.

TO START THE FRONT PTO, PULL KNOB OUT AND LIFT UP (NOTE: KNOB WILL RETRACT INTO RUN POSITION).

POSITION AT WHICH PTO WILL RUN IF STARTING PROCEDURE HAS BEEN COMPLETED (NOTE: IF PTO IS RUNNING AND UNIT IS SHIFTED INTO REVERSE OR OPERATOR LEAVES THE SEAT, THE PTO WILL DISENGAGE TO REACTIVATE PTO, PULL KNOB OUT AND LIFT UP INTO START POSITION.)

**HYDRAULIC LIFT LEVER**

PUSH TO LOWER  
PULL TO RAISE

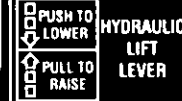

**BRAKE PEDAL**

NEUTRAL POSITION  
BRAKE POSITION



**CHOKE**



**DOWN STOP ADJUSTMENT**

HIGHER  
LOWER



REFER TO OPERATOR'S MANUAL



**WARNING**

**AVOID SERIOUS INJURY OR DEATH      READ OPERATOR'S MANUAL**

- GO UP AND DOWN SLOPES, NOT ACROSS. • AVOID SUDDEN TURNS.
- DO NOT OPERATE THE UNIT WHERE IT COULD SLIP OR TIP.
- IF MACHINE STOPS GOING UPHILL, STOP PTO AND BACK DOWNHILL SLOWLY.
- DO NOT MOW WHEN CHILDREN OR OTHERS ARE AROUND. • NEVER CARRY CHILDREN.
- LOOK DOWN AND BEHIND BEFORE AND WHILE BACKING.
- KEEP SAFETY DEVICES (GUARDS, SHIELDS, AND SWITCHES) IN PLACE AND WORKING.
- REMOVE OBJECTS THAT COULD BE THROWN BY THE BLADE(S).
- KNOW LOCATION AND FUNCTION OF ALL CONTROLS.
- BE SURE BLADE(S) AND ENGINE ARE STOPPED BEFORE PLACING HANDS OR FEET NEAR BLADE(S).
- BEFORE LEAVING OPERATOR'S POSITION, DISENGAGE PTO, PLACE THE SHIFT LEVER IN NEUTRAL, ENGAGE BRAKE LOCK, SHUT ENGINE OFF AND REMOVE KEY.

40  
2679 (684)

**MODEL 1864 SHOWN  
GENERAL SAFETY INSTRUCTIONS CAUTION -  
LOCATED ON THE FRAME COVER**

# TO THE OWNER

Assembled in this manual are operation, lubrication and maintenance instructions for the *Cub Cadet* 1863 and 1864 Tractors. The material has been prepared in detail to help you better understand the correct care and efficient operation of your tractor. Before you operate the tractor, study this manual carefully. Additional copies may be ordered from your dealer at a nominal price.

Your local authorized dealer is interested in the performance you receive from your tractor. He has factory-trained servicemen, informed in the latest method of servicing tractors, modern tools, and original-equipment service parts which assure proper fit and good performance.



## CAUTION

DO NOT TOW Tractor. Towing or pushing the tractor for more than a few feet may damage the hydrostatic drive unit.

The *Cub Cadet* 1863 and 1864 Tractors have a hydrostatic drive unit and will require minimum service if recommended operation and maintenance procedures are followed.

To obtain top performance and assure economical operation the tractor should be inspected, depending on its use, periodically, or at least once a year, by your authorized dealer.

When in need of parts, always specify the model, chassis and engine serial numbers, including the prefix and suffix letters. Write these serial numbers in the space provided on this page.

Should you have difficulties with the unit, consult your authorized dealer. **UNDER NO CIRCUMSTANCES SHOULD YOU ATTEMPT TO SERVICE THESE UNITS YOURSELF.** Only your dealer is authorized to repair or replace units on this drive under the terms of the warranty. Should you desire additional information not found in this manual, contact your authorized *Cub Cadet* dealer.

## SERIAL NUMBER LOCATION



## NOTE

LEFT and RIGHT indicate the left and right sides of the tractor when facing forward in the driver's seat. Reference to FRONT indicates grille end of the tractor; to REAR the drawbar end.

Chassis serial number plate is located near left rear fender. (See Figure 1.)

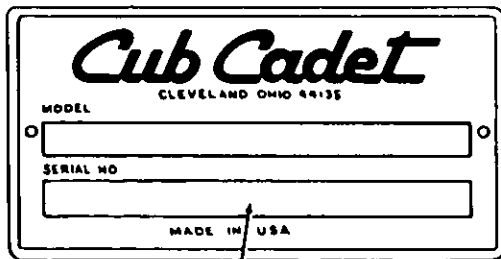

CHASSIS SERIAL NUMBER

Figure 1

The engine identification numbers appear on a decal affixed to the engine shrouding. (See Figure 2.)

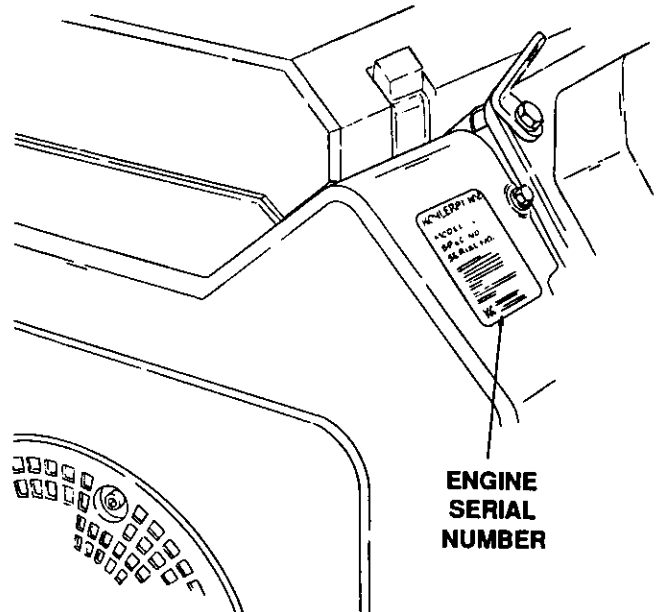

ENGINE SERIAL NUMBER

Figure 2

MODEL \_\_\_\_\_  
DELIVERY DATE \_\_\_\_\_

## SECTION I. CONTROLS

Your *Cub Cadet* Tractor has been safety engineered. Thoroughly acquaint yourself with all the instruments

and controls before attempting to start or operate the tractor.

- A. Low Oil Indicator
- B. Low Fuel Indicator
- C. Amp Indicator
- D. Hour Meter
- E. Reverse "R" Indicator
- F. Disengage PTO Indicator
- G. Depress Left Pedal Indicator
- H. Speed Control Lever
- I. Lift Height Indicator
- J. Ignition/Light Switch
- K. Tilt Wheel Release Lever
- L. Choke Control
- M. Down Stop Adjustment Rod
- N. Seat Adjustment Lever (Not Shown)
- O. Brake Lock
- P. Brake Pedal
- Q. Hydraulic Lift Control Lever
- R. Throttle Control Lever
- S. Front Power Take-Off (PTO) Control Switch
- T. Hydrostatic Relief Valve Lever (1863 only)
- U. Fuse (Not Shown)
- V. Safety Interlock Switches (Not Shown)

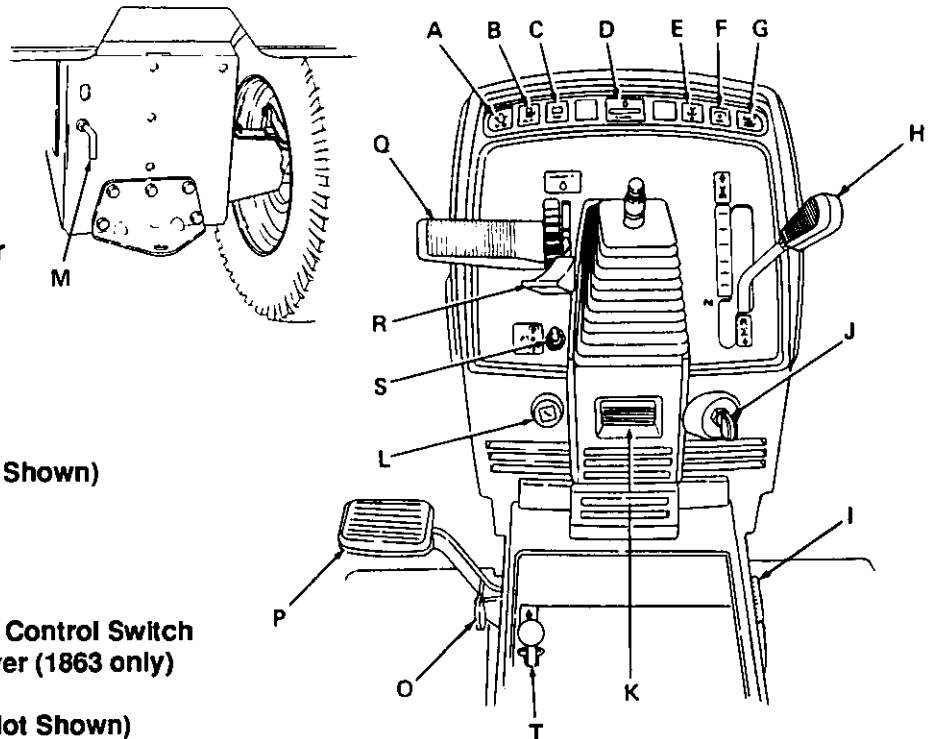

Figure 3

(1863 ONLY)

### A. LOW OIL INDICATOR

This indicator will illuminate when the oil level is low.



### CAUTION

When LOW OIL indicator illuminates, stop the tractor and check the oil level. Continuing to operate the tractor could result in severe damage to the engine.

### B. LOW FUEL INDICATOR

This indicator will illuminate when the fuel level in the fuel tank is low.

### C. AMP INDICATOR

This indicator will illuminate when a problem exists with the charging system or the battery. If this indicator illuminates, stop the tractor and contact your *Cub Cadet* Dealer.

### D. HOUR METER

The hour meter indicates the actual hours of engine operation. This enables the operator to determine when lubrication, change of oil or periodic inspections are necessary. It also provides a means of computing cost of specific jobs. The hour meter operates whenever the engine is running or the ignition key is in the "ON" position.

### E. REVERSE "R" INDICATOR

This indicator is illuminated only when attempting to start tractor while it is in reverse. The "R" indicator must be off before the tractor can be started.

### F. DISENGAGE PTO INDICATOR

This indicator will illuminate if an attempt is made to start the tractor with the PTO switch engaged. This indicator must be off before the tractor can be started. When starting the tractor, this indicator will briefly flash.



### G. DEPRESS LEFT PEDAL INDICATOR

This indicator will illuminate when an attempt is made to start the tractor with the brake pedal not fully depressed.

### H. SPEED CONTROL LEVER



Do not rest your foot on the brake pedal while driving the tractor as this would cause the speed control lever to return to the "N" position.

The lever is used to select any speed from a standstill "N" position to eight miles per hour in the forward direction and four miles per hour in the reverse direction.

Moving the speed control lever forward provides increased forward speed, and moving the lever rearward provides the reverse speeds. (See Figure 3.)

### I. LIFT HEIGHT INDICATOR

The lift height indicator will indicate the height of deck attachment when installed. (See Figure 4).

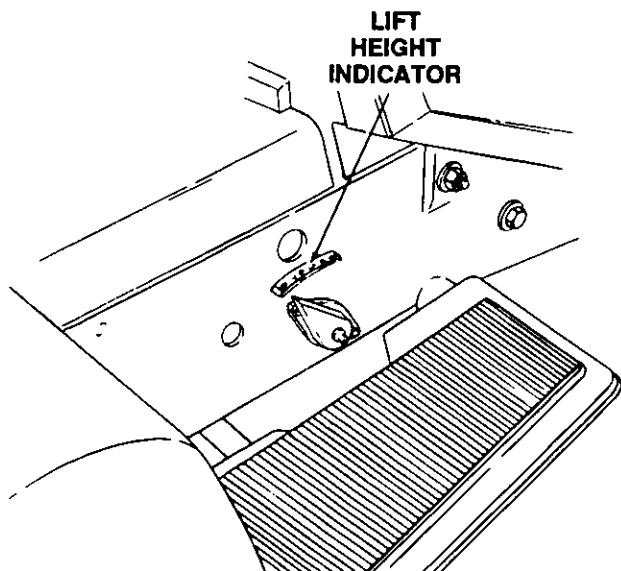

Figure 4

### J. IGNITION/LIGHT SWITCH



### WARNING

Remove the key from the tractor when the tractor is not in use to prevent accidental starting and battery discharge.

The combination lights and ignition switch is a four-position switch. (See Figure 5.)

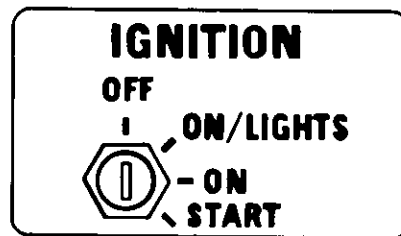

Figure 5

### K. TILT WHEEL RELEASE LEVER

The tilt wheel release lever is used to adjust the steering wheel forward away from the operator or rearward towards the operator. Refer to **ADJUSTING THE STEERING WHEEL** in Section III.

### L. CHOKE CONTROL

The choke control is operated manually. Pull knob out to choke engine. Push knob in to open choke. (See Figure 3.)

### M. DOWN STOP ADJUSTMENT ROD

The down stop adjustment rod adjusts the downward travel of the lift shaft assembly which allows an attached mower deck to return to a preset height. (See Figure 6.)

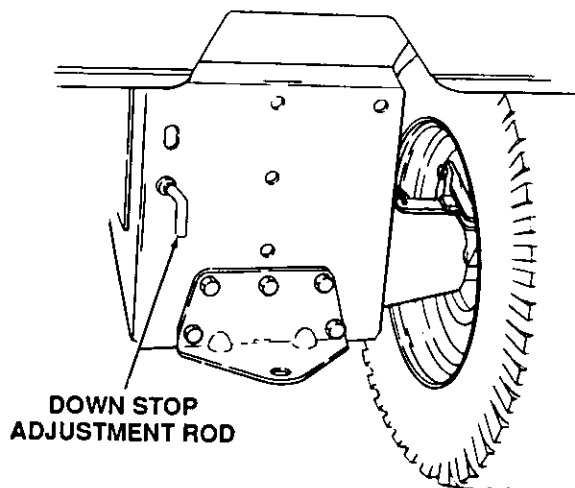

Figure 6

With the implement at a desired height, turn the down stop adjustment rod clockwise until it stops turning

freely. Turning the adjustment rod clockwise increases the preset height; turning counterclockwise lowers the preset height.

### NOTE

Be careful when turning the adjustment rod counterclockwise. It is possible to disengage the adjustment rod from the lift cam.

#### N. SEAT ADJUSTMENT LEVER

The seat adjustment lever is used to move the seat forward or rearward. Refer to **ADJUSTING THE SEAT** in Section III.

#### O. BRAKE LOCK



### WARNING

The hydrostatic transmission will not hold the tractor on a hill. In a short period of time (depending on the steepness of the hill) the oil will drain from the transmission and allow the tractor to roll downhill. To avoid an accident and/or possible injury, engage the brake lock.

Always engage the brake lock when dismounting the tractor. To lock the brake, depress brake pedal and place the brake lock in the engaged position. (See Figure 7.) To disengage the lock, press down on the pedal, lift the lock up and place it in the disengaged position.

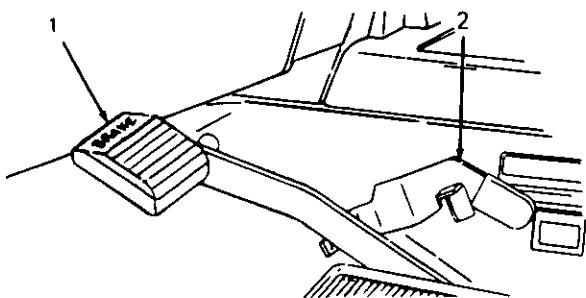

Figure 7

1. Brake Pedal
2. Brake Lock

#### P. BRAKE PEDAL

### NOTE

Do not rest your foot on the brake pedal while driving the tractor as this would cause the speed control lever to return to the "N" position.

Brake pedal must be pressed all the way down to activate the safety starting switch. When brake pedal is in the depressed position, it automatically moves the speed control lever to the "N" position if the linkage is properly adjusted. (See Figure 3.)

#### Q. HYDRAULIC LIFT CONTROL LEVER

### NOTE

The engine must be running in order to operate the hydraulic lift.

The hydraulic lift control lever controls the raising and lowering of equipment used with the tractor, if installed. The control lever is spring-loaded. To raise the equipment, pull up on the lever. To lower the equipment, push down on the lever. (See Figure 8.)

#### HYDRAULIC LIFT CONTROL LEVER

#### THROTTLE CONTROL LEVER

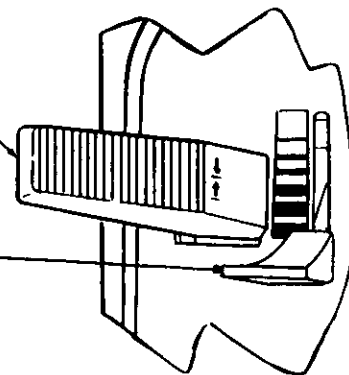

Figure 8

#### R. THROTTLE CONTROL LEVER

This lever controls the speed of the engine. When set in a given position, it will maintain a uniform engine speed. (See Figure 8.)

### NOTE

When using power take-off operated equipment, best performance is achieved with the throttle lever in the "FAST" position.



This symbol shows slow position.

This symbol shows fast position.

### S. FRONT POWER TAKE-OFF (PTO) CONTROL SWITCH

The power take-off (PTO) control switch, which is located on the left side of the instrument panel (see Figure 3), operates an electric clutch. This electric clutch controls the engagement ("RUN") or disengagement ("OFF") of the front PTO.

### T. HYDROSTATIC RELIEF VALVE LEVER (1861 only)

The hydrostatic relief valve lever is located on the frame cover.

The relief valve disconnects the transmission from the pump so the unit can be pushed a short distance by hand without running.

1. To engage the relief valve (making the tractor free-wheeling), pull the lever up and back. (See Figure 9.)

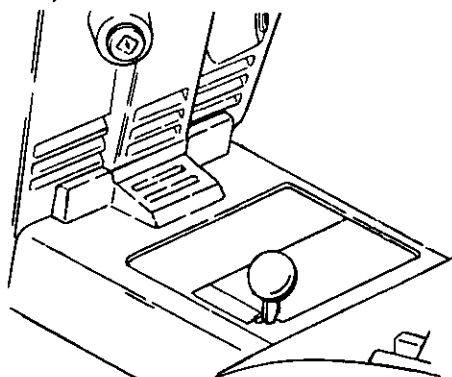

**ENGAGE POSITION**

**Figure 9**

2. To disengage the relief valve, release the lever by pushing it forward. (See Figure 10.)

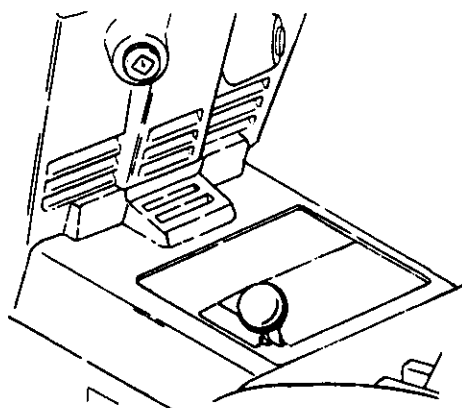

**DISENGAGE POSITION**

**Figure 10**

### U. FUSE

The fuse is located under the hood on the left side of the engine compartment. It is installed to protect the tractor's electrical circuitry and components from damage caused by excessive amperage overload. (See Figure 11.)

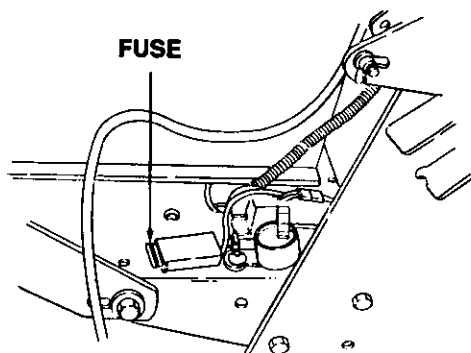

**Figure 11**

### V. SAFETY INTERLOCK SWITCHES

This tractor is equipped with a safety interlock system for the protection of the operator. If the interlock system should ever malfunction, do not operate the tractor. Contact your authorized *Cub Cadet Dealer*. The safety interlock system prevents the engine from cranking or starting unless the brake pedal is fully depressed, and the PTO switch is in the "OFF" position.

The safety interlock system will automatically shut off the engine if the operator leaves the seat before engaging the brake lock.

The safety interlock system will automatically disengage the PTO if the operator leaves the seat with the PTO in the "RUN" position, or the unit is shifted into reverse with the PTO in the "RUN" position. To reengage the PTO, shift into neutral ("N"), move the PTO switch into the "OFF" position and then engage the PTO while seated.

### FUEL TANK

The fuel tank is located in the rear of the tractor. The fuel tank filler cap is located on the left rear fender. The main fuel shut-off valves are located on the bottom (left and right sides) of the tank. These valves

control the flow of fuel to the engine. To open the valves turn the knobs counterclockwise until they stop. To close the valves turn the knobs clockwise until they are tight. (See Figure 12.)

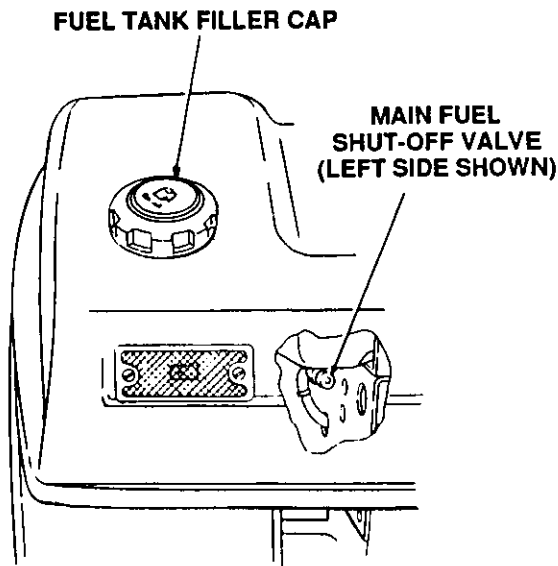

Figure 12

### HOOD AND SIDE PANELS

The tractor hood is arranged to swing up and forward for easy access to the engine compartment. (See Figure 13.) Whenever engine maintenance is required, the side panels can be removed.

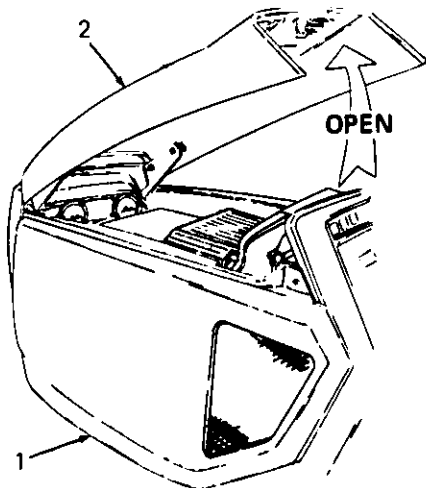

Figure 13

1. Side Panel (One On Each Side)
2. Hood



### WARNING

If engine is hot, use caution not to burn yourself when removing the side panels.

To remove either right or left side panel, proceed as follows: Engage the brake lock. Raise the hood. Refer to Figure 14 and at rear of side panel remove wing nut and flat washer.

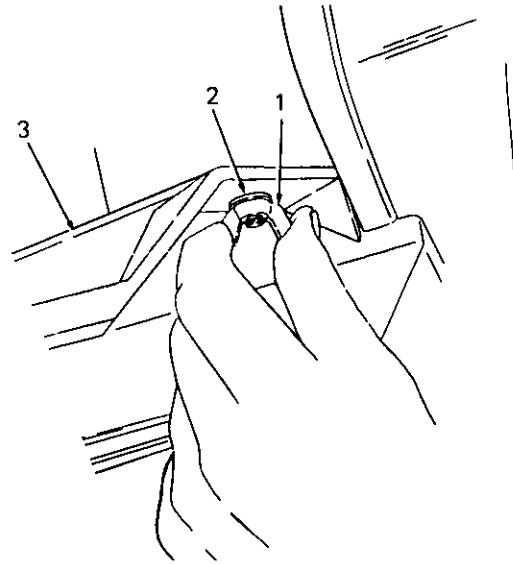

Figure 14

1. Wing Nut
2. Flat Washer
3. Side Panel

Remove front snaps by applying pressure to side of grille and gently pulling on side panel until snaps pop out of grille side flange. (See Figure 15.)



### NOTE

Be sure both top and bottom snaps have popped out.

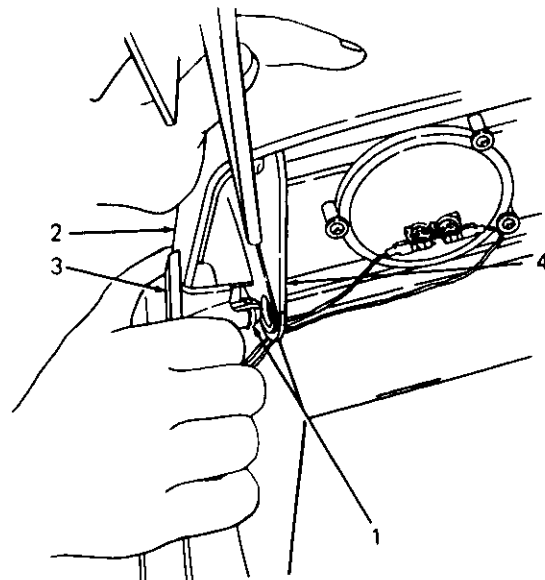

Figure 15

1. Snap
2. Grille
3. Side Panel
4. Grille Side Flange

See Figure 16 and locate lock tab and dash panel lock.

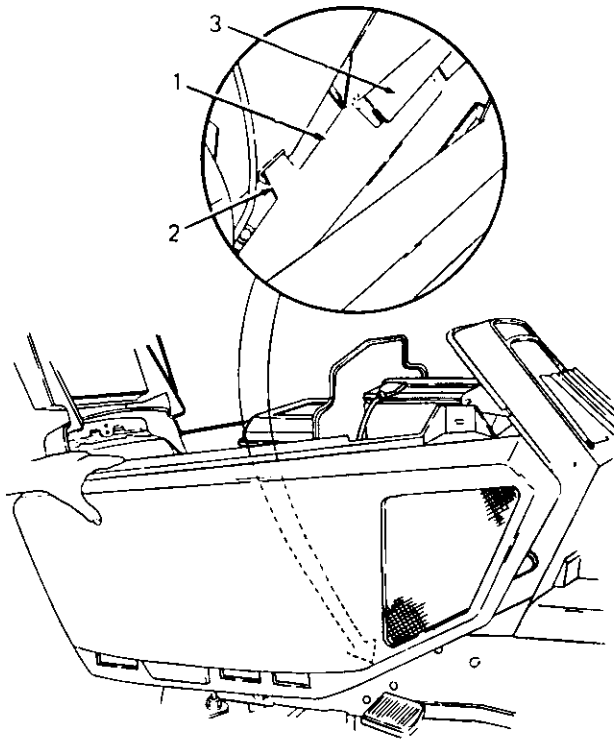

Figure 16

1. Side Panel
2. Lock Tab
3. Dash Panel Lock

To remove lock tab, (A) gently pull front of side panel towards you and (B) pull up. Then (C) slide side panel forward to disengage dash panel lock. (Refer to Figure 17.)

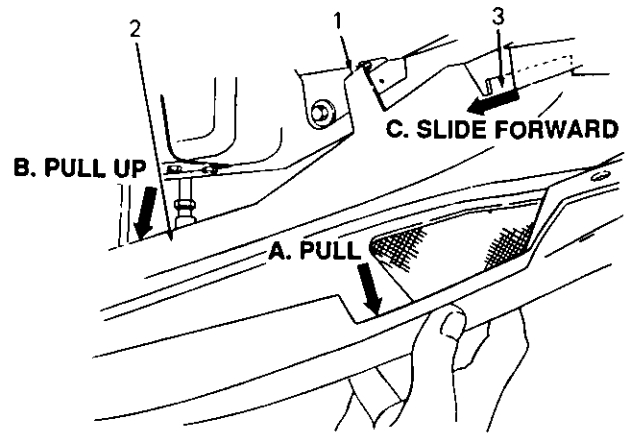

Figure 17

1. Lock Tab
2. Side Panel
3. Dash Panel Lock

Installation of either side panel is exactly the reverse of removal. After inserting snaps at front of panel into grille side flange holes, make sure upper front corner of side panel is inside of lip on grille as shown in Figure 18.

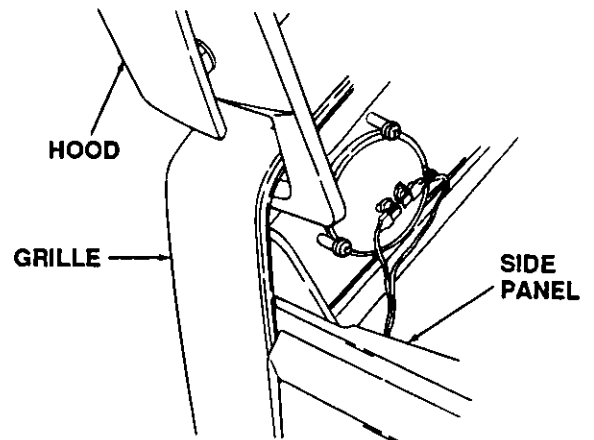

Figure 18

## SECTION II. OPERATION



### WARNING

**RECEIVE INSTRUCTION** - Read operator's manual. Learn to operate this machine **SAFELY**. Don't risk **INJURY** or **DEATH**.

1. Before starting engine or operation: Be familiar with controls. Be in operator's position with speed control lever in neutral, PTO turned off and brake depressed.
2. Keep shields in place. Keep away from moving parts.
3. **NO RIDERS!** Keep all people and pets a safe distance away. Look before backing up.
4. Don't point mower discharge at people.
5. Avoid slopes. Tractors can be rolled over.
6. Before leaving operator's position: Shut off PTO. Place speed control lever in neutral. Engage brake lock. Shut off engine. Remove ignition key. Wait for all movement to stop before servicing or cleaning.
7. Do not fill gasoline tank when engine is running or while engine is hot. Tighten cap securely.

### BEFORE OPERATING YOUR TRACTOR

1. Before you operate the tractor study this manual carefully. It has been prepared to help you operate and maintain your tractor with utmost efficiency.
2. Familiarize yourself with the operation of all the instruments and controls.
3. Fill the tank with unleaded gasoline with a pump sticker octane rating of 87 or higher. Unleaded gasohol is acceptable as long as the ethyl alcohol blend does not exceed 10 percent. Make sure before you fill the tank that the gasoline is clean and fresh.
4. Check the engine and transmission oil levels.
5. Clean the air cleaner element if necessary.
6. Check the tire inflation pressures.
7. Adjust the seat and steering wheel for operator's maximum comfort, visibility and complete control of the tractor.

8. Remove the side panels and clean any accumulated grass and debris from the intake fan on engine.
9. Make certain that the backside of the grille insert is clean and unobstructed. Push down on the top of the grille insert and pull forward as shown in Figure 19. Lift the grille insert up removing the tabs from the bottom of the grille housing. Remove by hand any accumulated grass and debris.
10. Refer to various sections of the Owner's Manual for additional information.

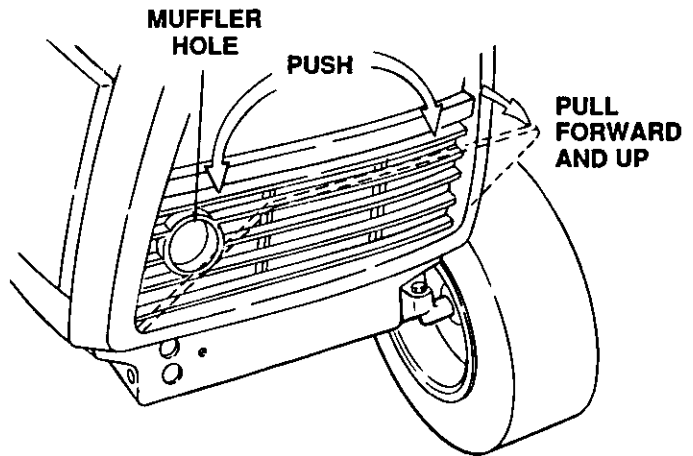

Figure 19

### STARTING THE ENGINE



### WARNING

Do not operate tractor if the interlock system is malfunctioning. It is a safety device designed for protection of the operator.



### WARNING

Operator must be seated before starting the tractor.



### NOTE

This unit is equipped with a safety interlock system for the protection of the operator.

The safety interlock system prevents the engine from cranking or starting unless the

brake pedal is fully depressed, and the PTO engagement switch is in the "OFF" position.

The safety interlock system will automatically shut off the engine if the operator leaves the seat before engaging the brake lock.

 **NOTE**

The safety interlock system will automatically disengage the PTO if the operator leaves the seat with the PTO in the "RUN" position, or the unit is shifted into reverse with the PTO in the "RUN" position. To reengage the PTO, place the speed control lever in neutral ("N"), move the PTO switch into the "OFF" position and then engage the PTO while seated.

1. Operator must be seated.
2. Place the throttle midway between the "SLOW" and "FAST" position.
3. Pull choke control knob to full choke position. Less choking may be necessary due to variations in temperature, grade of fuel, etc. Little or no choking will be needed when the engine is warm.
4. Place the PTO switch in the "OFF" position.
5. Place the speed control lever in neutral ("N").
6. Fully depress the brake pedal.

 **NOTE**

The speed control lever will automatically return to neutral when the brake pedal is pressed all the way down, and the linkage is properly adjusted.

7. Turn the ignition key clockwise to the "START" position and release it as soon as the engine starts; however, do not operate the starter for more than 10 seconds at any one time. If the engine does not start within this time, turn the key "OFF" and wait a few minutes, then try again.
8. After the engine starts, slowly release the brake pedal and gradually push the choke control knob all the way in. Do not use the choke to enrich the fuel mixture, except as necessary to start the engine.

**STOPPING THE ENGINE**



Remove the key to prevent accidental starting and battery discharge if equipment is left unattended.

Place the PTO switch in the "OFF" position. Move the throttle control lever midway between "SLOW" and "FAST" positions. Turn the key to the "OFF" position. Remove key from ignition switch.

**TRACTOR BREAK-IN PROCEDURE**



Never operate a new engine immediately under full load. Break it in carefully as shown in the table below.

Period	Engine Throttle Control Lever Position			Load
	½	¾	Full	
1st hour		X		None
2 hour	X		X	Light drawbar load or Mowing with tractor at slow speed
3rd through 13th hour		X	X	Medium drawbar load or Normal mowing

**COLD WEATHER STARTING**



During operation do not run the engine in confined area such as storage building any longer than is necessary. Immediately move the tractor outside into the air.



Operator must be seated before starting the tractor.

## NOTE

In cold weather the starting motor may disengage prematurely. This is caused by the engine firing once but failing to continue running. If this happens several times, the engine will be flooded and it will be necessary to leave the throttle in the "SLOW" position but push the choke in all the way; then turn the ignition key to the "START" position and slowly pull the choke out to the position which will cause the engine to start and continue running. If the engine falters after putting tractor into motion, pull the choke out part way until the engine runs smoothly, then gradually push the choke back in as the engine warms.

Engine starting is possible in cold weather providing the correct weight of engine oil is used, the battery is fully charged and the proper starting procedure is followed. The best procedure for starting at temperatures near or below freezing are as follows:

1. Operator must be seated.
2. Move the throttle lever midway between the "SLOW" and "FAST" position.
3. Pull the choke all the way out into the full choke position.
4. Place the PTO switch in the "OFF" position.
5. Place the speed control lever in neutral ("N").
6. Fully depress the brake pedal.
7. Move the key switch into the "START" position and hold until the engine starts; however, do not operate the starter for more than 10 seconds at any one time. As soon as the engine starts, slowly push the choke in part way.

## DRIVING THE TRACTOR



### WARNING

(1864 ONLY)

When the engine is off, the tractor will become very difficult to steer. This is because the engine must be on for the power steering to operate. Do not turn off engine until tractor comes to a complete stop or damage to equipment or injury to persons might occur.



### CAUTION

Avoid sudden starts, excessive speed and sudden stops.



### CAUTION

Do not leave the seat of the tractor without depressing the brake pedal and engaging the brake lock. If leaving the tractor unattended, also turn the ignition key off and remove the key.



### NOTE

(1864 ONLY)

Hydraulic power for the power steering will take priority over installed hydraulically driven accessories.



### NOTE

When using power take-off operated equipment, best performance is achieved with the throttle lever in the "FAST" position.

1. Depress the brake pedal to release the brake lock, and let the pedal up. Move the throttle lever to the position where the engine operates best for the load to be handled.
2. Start the tractor in motion by moving the speed control lever slowly forward or rearward to desired speed.

### DRIVING ON SLOPES

(Refer to "SLOPE GAUGE" on page 41 in order to help determine slopes where you may not operate safely.)



### WARNING

Do not mow on inclines with a slope in excess of 15 degrees (a rise of approximately 2-1/2 feet every 10 feet). A tractor could overturn and cause serious injury.



### WARNING

Operate tractor up and down slopes, never across slopes.





## CAUTION

Always drive up or down the face of a slope. Do not drive so that the tractor may tip over sideways.

Before operating the tractor on any slope, walk the slope to look for possible hazards such as rocks, mounds, ruts, stumps or other surface irregularities which could cause an upset.

Back the tractor with implement up the steepest portion of each slope you intend to work. If the tractor cannot negotiate the slope in reverse, the slope is too steep to be worked.

Avoid turns when driving on a slope. If a turn must be made, turn down the slope. Turning up a slope greatly increases the chance of a roll over.

Avoid stopping when driving up a slope. If it is necessary to stop while driving up a slope, start up smoothly and carefully to reduce the possibility of flipping the tractor over backward.

### STOPPING THE TRACTOR



## CAUTION

Always engage brake lock, lower equipment and shut off engine before dismounting. Never try to start engine from ground.

Fully depress the brake pedal. When tractor has stopped, make sure the speed control lever is in the neutral ("N") position. Before dismounting always disengage the PTO switch, engage the brake lock and turn the ignition "OFF."

### DRAWBAR

Drawbar equipment must be hitched to the tractor only at the hitch hole in the drawbar. (See Figure 20.)

### OPERATING THE FRONT POWER TAKE-OFF (PTO) CLUTCH



## NOTE

Be certain to follow break-in instructions listed below.

1. Set the throttle lever to at least 3/4 speed.
2. Flip the toggle switch to the "RUN" position. (See Figure 21.)
3. Advance throttle to operating speed (full speed).

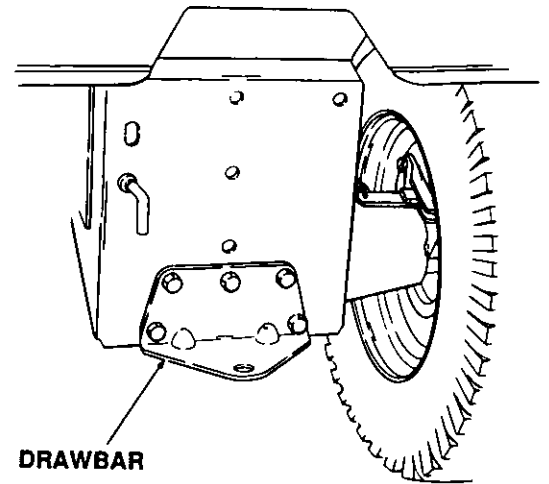

Figure 20

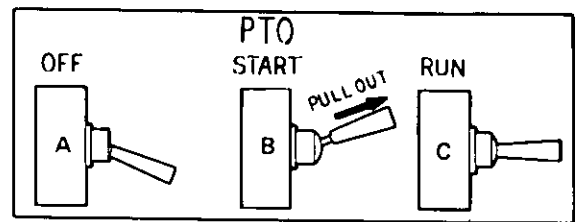

Figure 21

4. The operator must remain in tractor seat at all times. If operator should leave tractor seat without turning off the power take-off switch, the PTO will automatically disengage.
5. PTO switch must be in the "OFF" (A) position when shifting the tractor into reverse or the PTO will shut off automatically. To reengage the PTO, shift unit into neutral. Move PTO switch to "OFF" (A) position. Then pull knob out and lift up to "START" (B) position and release.

### FRONT PTO CLUTCH BREAK-IN PROCEDURE

To break in the components and increase the life of the clutch assembly, proceed as follows.

1. Attach mowing deck, snow thrower, etc. to the tractor.
2. Adjust the belt tension as recommended in attachment owner's manual.
3. Run at 50% throttle.
4. Engage and disengage the PTO five times without any load (not cutting grass, not blowing snow, etc.). Ten seconds on/ten seconds off.
5. Increase to 75% throttle.
6. Engage and disengage the PTO five times without any load (not cutting grass, not blowing snow etc.). Ten seconds on/ten seconds off.

## SECTION III. ADJUSTMENTS

### ADJUSTING THE SEAT



#### WARNING

Do not adjust the seat when the tractor is moving. Adjusting the seat while the tractor is moving could cause the operator to lose control of the tractor.

Before starting the tractor, adjust the seat forward or rearward to the most comfortable driving position. To reposition the seat, move the seat adjustment lever (Figure 22) to the left and slide the seat forward or rearward. Release the adjustment lever when seat is comfortably positioned. Gently rock the seat forward and rearward once to be sure seat is locked in place.

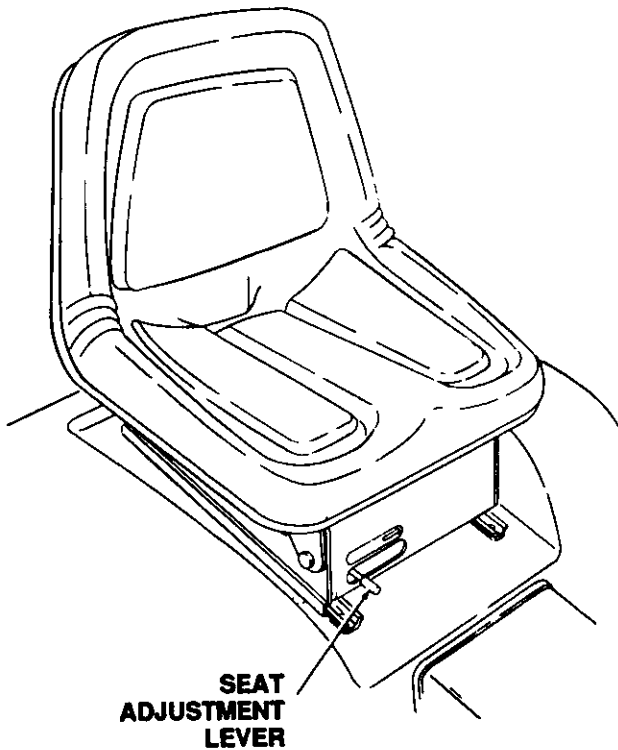

Figure 22

### ADJUSTING THE STEERING WHEEL



#### WARNING

Do not adjust the steering wheel when the tractor is moving. Adjusting the steering wheel while the tractor is moving could cause the operator to lose control of the tractor.

Before starting the tractor, adjust the steering wheel forward or rearward to the most comfortable position. To position the steering wheel, push the tilt wheel release lever down (as shown in Figure 23) and move the steering wheel forward or rearward. Release the lever when the steering wheel is comfortably positioned. Gently push the steering wheel forward and rearward once to be sure wheel is locked in place. Make sure tilt wheel release lever is all the way up as shown in Figure 24.

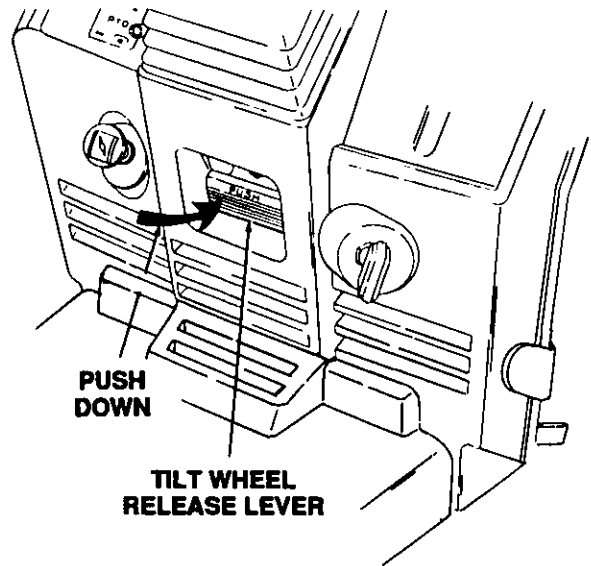

Figure 23

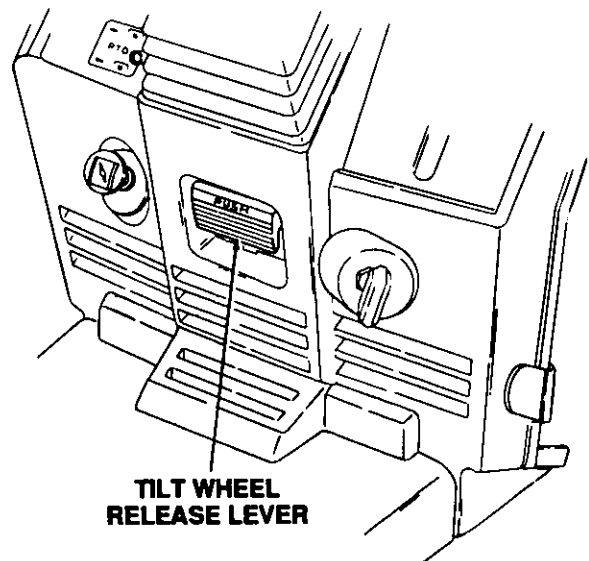

Figure 24

## ADJUSTING THE POWER TAKE-OFF CLUTCH



### WARNING

To avoid possible injury, move speed control lever into neutral, engage the brake lock and turn the ignition "OFF" before working on the machine.



### WARNING

The clutch may be hot. Allow the engine and clutch to cool before adjusting the clutch.

The clutch is factory adjusted and should not require further adjustment under normal operating conditions. However, if the clutch fails to operate properly, check as follows:

Using a feeler gauge, check the air gap. (See Figure 25.) Insert feeler gauge into one of three access slots located around the outside of the brake plate. The air gap should be .015 inch. Adjust the self-locking nuts to obtain the proper clearance. Repeat the operation in all three access slots.

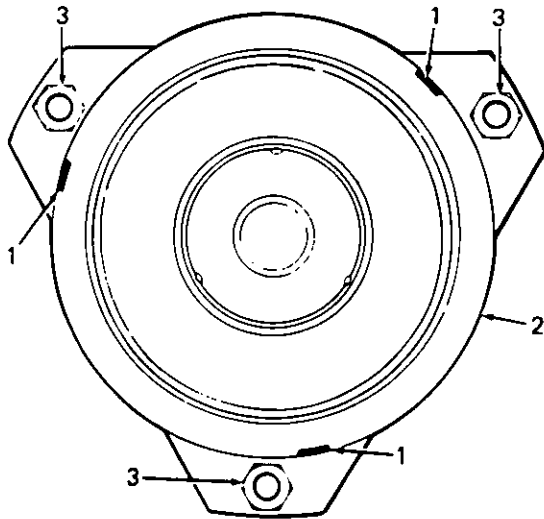

Figure 25

1. Access Slots
2. Brake Plate
3. Self-Locking Nuts

## ADJUSTING THE BRAKES

### Brake adjustment

During normal operation on this machine, the brakes are subject to wear and will require periodic examination and adjustment.

### Brake adjustment check

1. To check brake adjustment, place a 1 inch thick wood block between the brake pedal and the brake lock tab (see Figure 26).
2. With the 1 inch thick wood block installed, the brake disc pads should be applying a light amount of friction against the brake disc rotor. If they are not, the brakes need adjustment.

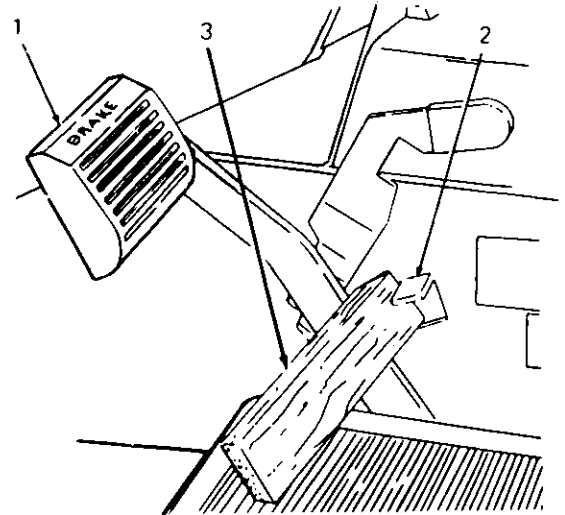
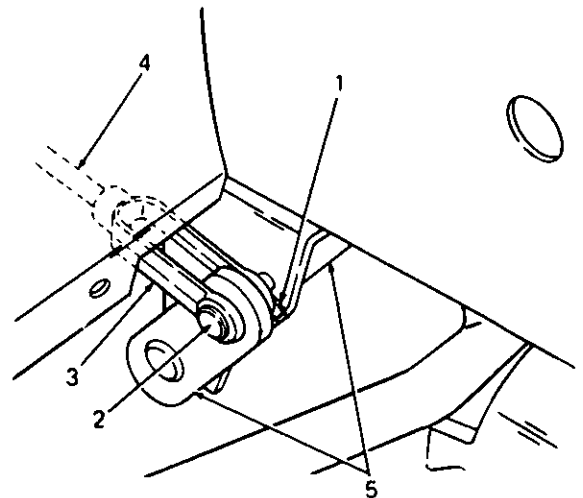

Figure 26

1. Brake Pedal
2. Brake Lock Tab
3. 1 Inch Thick Wood Block

With the brake pedal disengaged, remove the clevis pinned end of one of the brake rod assemblies from the jackshaft assembly by removing the cotter pin from the clevis pin. (See Figure 27.)



(RUNNING BOARD REMOVED FOR CLARITY)

Figure 27

1. Cotter Pin
2. Clevis Pin
3. Clevis
4. Brake Rod Assembly
5. Jackshaft Assembly

Thread the clevis onto the brake rod one turn. Reconnect the clevis to the jackshaft assembly. There should be a minimum amount of clearance (no drag) between the brake pads and the rotor. If not, repeat adjustment as necessary. (See Figure 28.)

**NOTE**

Figure 28 is shown with the wheel and fender assembly removed for clarity.

Repeat the adjustment on the brake rod assembly on the other side of the tractor.

Recheck brake adjustment per **Brake adjustment check** and ensure proper brake operation before operating the tractor.

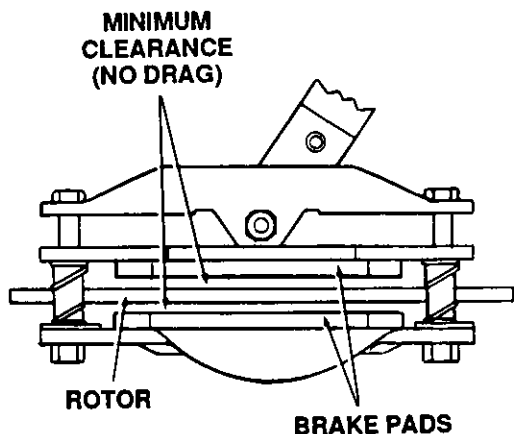

Figure 28

**WHEEL ALIGNMENT**

The front wheels should toe-in approximately 1/8 inch.

Measure the distances A and B on the front wheels. (See Figure 29.)

**NOTE**

Dimension B should be approximately 1/8 inch less than dimension A.

For adjustments on toe-in, see your authorized *Cub Cadet* dealer.

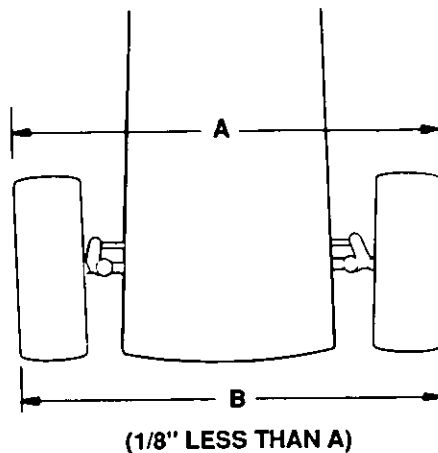

Figure 29

**FRONT WHEEL ADJUSTMENTS**

Check the front wheels to ensure that the turning radius of the unit is equal in both directions. Turn the wheels all the way to the left. Measure the angle of the wheel to the frame. Turn the wheel all the way to the right and repeat the measurement. The angles shall be equal.

**NOTE**

Power steering components are under hydraulic pressure. If not properly adjusted, serious damage may occur to steering components.

For adjustments on front wheels, see your authorized *Cub Cadet* dealer.

**PIVOT BAR ADJUSTMENT BOLTS**

**CAUTION**

The tractor must be checked every 50 hours of tractor operation for play between the front axle and the pivot bar adjustment bolts. Both adjustment bolt heads must fit against the front axle. If play is discovered, the pivot bar adjustment bolts must be adjusted.

If play is discovered between the front axle and the pivot bar adjustment bolt heads, adjust both bolts as follows: (See Figure 30.)

If play is discovered between the front axle and the pivot bar adjustment bolt heads, adjust both bolts as follows: (See Figure 30.)

1. Loosen jam nut 3 to 4 turns or as required.
2. Turn pivot bar adjustment bolt counterclockwise until it hits against the front axle.
3. Tighten jam nut.
4. Repeat the above steps for the other pivot bar adjustment bolt.

## CARBURETOR ADJUSTMENTS



Carburetor adjustments should be made only after the engine has warmed up.

The carburetor is designed to deliver the correct fuel-to-air mixture to the engine under all operating conditions. The high idle is set at the factory and cannot be adjusted. The low idle fuel adjusting needle is also set at the factory and normally does not need adjustment.

Minor carburetor adjustment may be required to compensate for differences in fuel, temperature, altitude or

load. Air cleaner and air cleaner cover must be assembled to carburetor when running engine.



If any adjustments are made to the engine while the engine is running (e.g., carburetor), disengage all clutches and blades. Keep clear of all moving parts and be careful of heated surfaces and muffler.



To avoid injury or an accident, engage single pedal brake lock, place speed control lever in neutral and make sure equipment is disengaged before starting engine to make carburetor adjustments.



Carbon monoxide fumes can be fatal! Do not make any adjustments to the carburetor in a confined area such as a storage building. Move the tractor outside into the air.

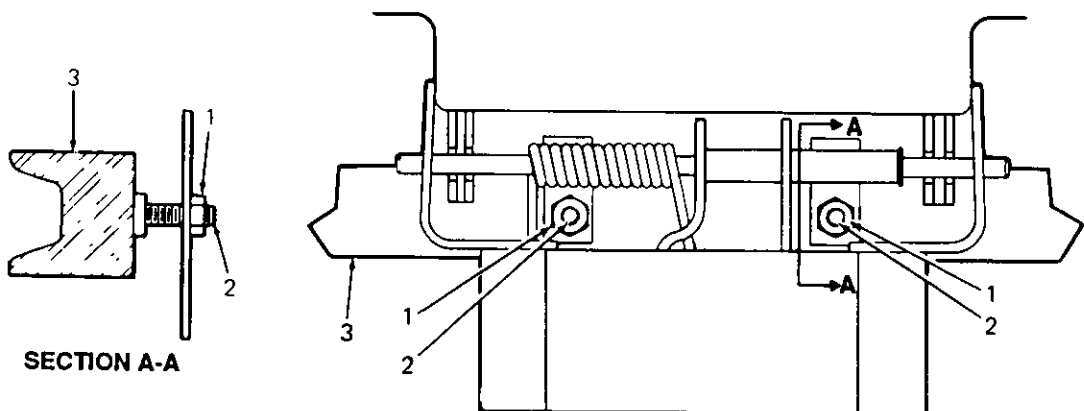

Figure 30

1. Jam Nut
2. Pivot Bar Adjustment Bolts
3. Front Axle

**NOTE**

Top half of heat baffle must be removed to make carburetor adjustments. (See Figure 31.)

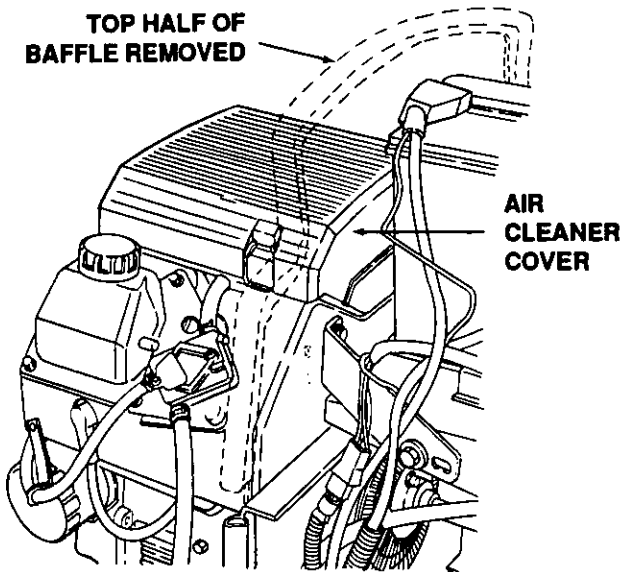

Figure 31

TWIN CYLINDER CARBURETOR ADJUSTMENT IS UNIQUE. SEE FIGURE 32 AND ADJUST CARBURETOR FUEL MIXTURE IN THE ORDER STATED AS FOLLOWS:



**CAUTION**

The tip of the low idle fuel adjusting needle is tapered to critical dimensions. Damage to the needle and the seat in carburetor body will result if the needle is forced.

With the engine stopped, turn the low idle fuel adjusting needle **IN** (clockwise) until it bottoms **LIGHTLY**.

**Preliminary settings:** Turn the adjusting needle out (counterclockwise) 1-1/2 turns from lightly bottomed position.

**NOTE: AIR CLEANER COVER MUST BE REMOVED TO ADJUST CARBURETOR IDLE SPEED**

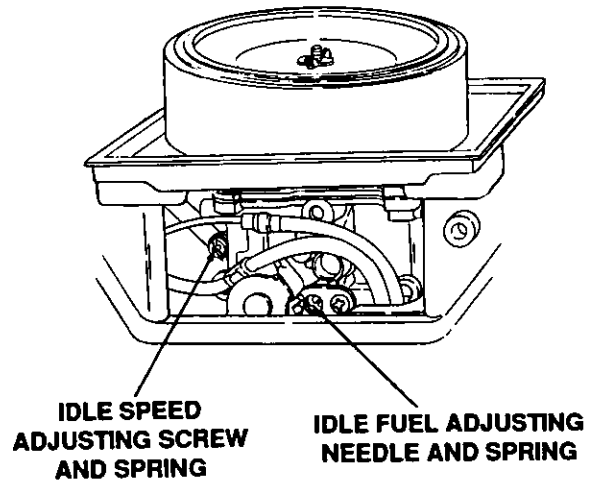

Figure 32

Start the engine and run at half-throttle for 5 to 10 minutes to warm up. The engine must be warm before making final settings.

**Low Idle Speed Setting:** Place the throttle control into the "idle" or "slow" position. Set the low idle speed to 1200 rpm ( $\pm 75$  rpm) by turning the low idle speed adjusting screw in or out. Check the speed using a tachometer.

**Low Idle Fuel Needle Setting:** Place the throttle into the "idle" or "slow" position. Turn the low idle fuel adjusting needle in (slowly) until engine speed decreases and then back out approximately 3/4 to 1 turn to obtain the best low speed performance.

Recheck the idle speed using a tachometer. Readjust the speed as necessary.

## SECTION IV. MAINTENANCE

### ENGINE OIL

The engine crankcase is filled with ship-away oil. This oil may be used for the first 5 hours of engine operation at temperatures between 0° and 90°F. If temperatures are not within this range, drain the oil from the oil filter and crankcase and replace with new oil as specified in the "LUBRICATION TABLE."

To aid starting, the selection of crankcase lubricating oils should be based on the lowest anticipated temperatures until the next drain period.

For oil change intervals of 100 hours the following oils are recommended.

Ambient Temperature	Viscosity (Grade SF/SG)
+32°F and above —	<i>Cub Cadet</i> Engine Oil S.A.E. 10W30 or S.A.E. 10W40
Below +32°F —	<i>Cub Cadet</i> Engine Oil S.A.E. 5W-20 or S.A.E. 5W-30

### CHECKING OIL LEVEL



Check the oil level only while the engine is stopped and tractor is level.

Check the oil level of the engine crankcase before each use to see that it is filled to the correct level. Always keep the oil level between the "FULL" and the "LOW" marks on the dipstick. (See Figure 35.) When checking the oil level, **engine must be cold**, the dipstick must be withdrawn and wiped clean, then inserted all the way and withdrawn for a true reading.

### DRAINING OIL AND REPLACING OIL FILTER



If engine is hot, use caution not to burn yourself when removing side panels, draining oil from crankcase and changing oil filter.



The oil filter should be changed at every oil change interval. The filters can be obtained through your *Cub Cadet* dealer under part number KH-12-050-08.

To drain oil from crankcase bend back retaining clamp holding drain hose to frame. (See Figure 33.) Allow

hose to drop below frame and under grille as shown in Figure 34. Clean around drain plug and remove from end of hose. Drain oil while engine is warm.

The oil filter is located behind the left side panel and is mounted on the engine. (See Figure 33.)

Before the filter is removed, clean the outside surface around the base of the filter. To remove filter turn counterclockwise using an automotive type filter wrench to loosen.

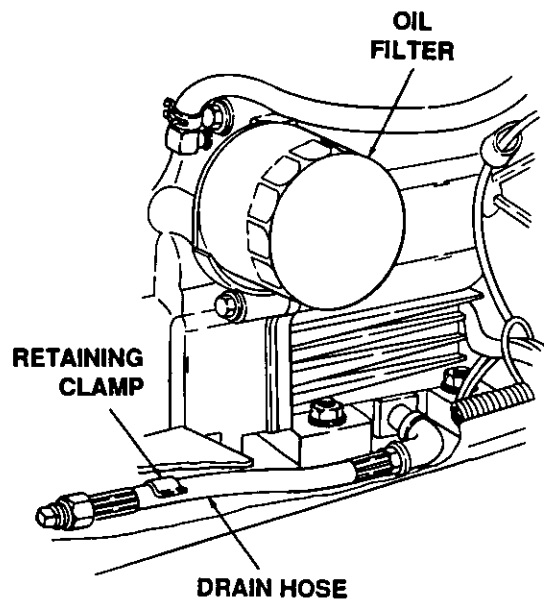

Figure 33

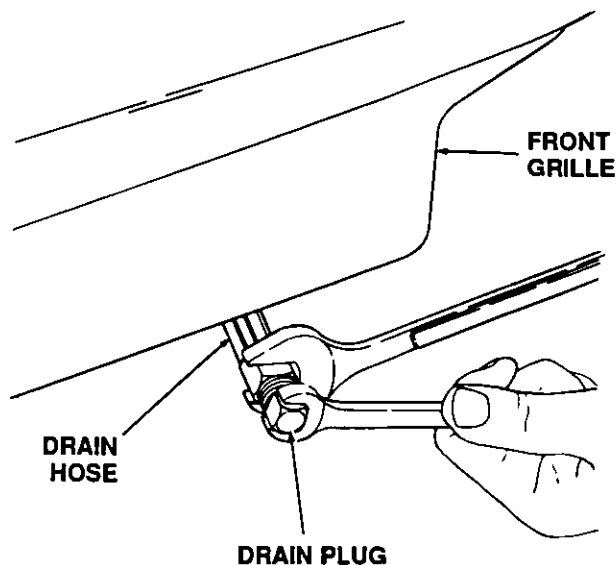

Figure 34

Before installing new filter, apply a coating of clean oil on the filter gasket. Thread filter on by hand until gasket seats in oil filter adapter. Tighten 1/2 to 3/4 turn more.

Install drain plug in drain hose and place hose into retaining clamp on frame. Bend clamp over hose as shown in Figure 33.

### FILLING THE CRANKCASE



### CAUTION

Never overfill the engine crankcase. Engine may overheat and/or damage may result if the crankcase is below the "LOW" mark or over the "FULL" mark.



### NOTE

For best results, fill to "FULL" mark on dipstick as opposed to adding a given quantity of oil. Always check level on dipstick before adding oil.

To fill the crankcase with oil, make sure the tractor is on a level surface. Clean the area around the oil filler cap and dipstick to prevent debris from entering the crankcase. Refer to Figure 35 and remove the oil filler cap and slowly pour oil (approximately 4 pints) into valve cover until oil level reads "FULL" on dipstick. Replace the oil filler cap and start engine. After 30 seconds, stop engine, check oil level and add if necessary. Check for leaks around oil filter and at drain plug.

### HYDROSTATIC DRIVE HYDRAULIC FLUID FILTER



### NOTE

Clean the outside area before removing the filter to keep dirt from getting into the transmission case. If a mower is mounted on the tractor, the mower must be removed to facilitate removal of the filter.



### NOTE

(1863 ONLY)

Remove the drain plug and allow the hydraulic fluid to drain into a clean container having a capacity of more than seven quarts. Replace the drain plug. (See Figure 36.)

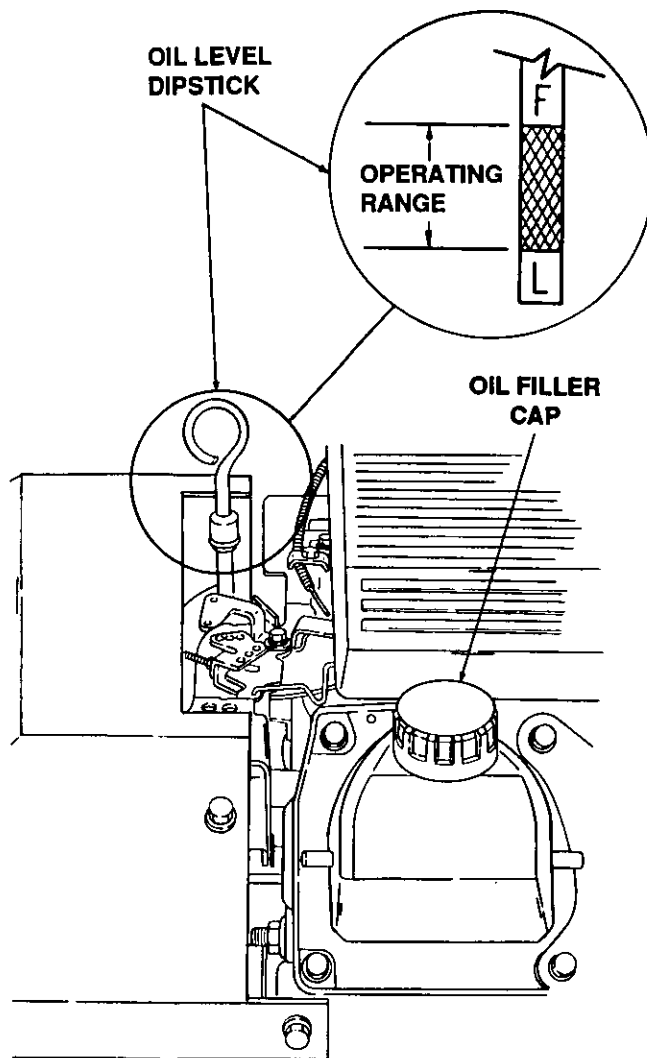

Figure 35

NOTE: FOR MODEL 1863 ONLY

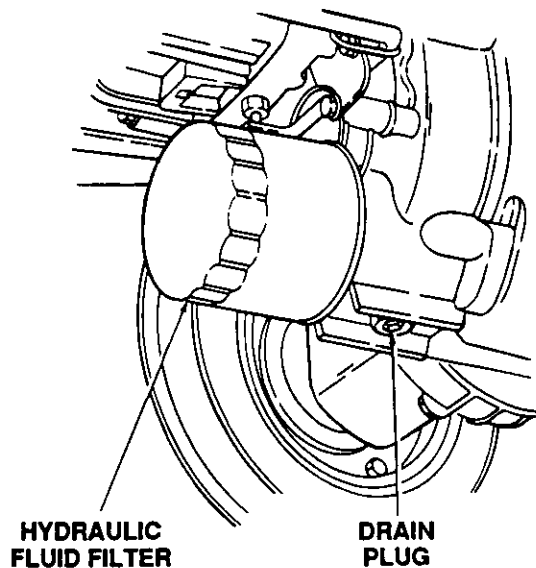

Figure 36





## CAUTION

If hydraulic fluid is to be reused, cover container holding drained fluid to prevent contamination. Contaminated hydraulic fluid can damage your unit.

Remove the throw-away-can-type filter and replace with a new filter after the first 10 and 50 hours of operation, and every 100 hours of operation thereafter. The filters can be obtained through your *Cub Cadet* Dealer under Part Number 723-3014.

To remove the filter, turn the filter counterclockwise using an automotive-type filter wrench.

Before installing the new filter, apply a coating of clean oil on the filter gasket. Thread the new filter on by hand until tight enough to seat the gasket. Loosen the filter. Then turn it until the gasket contacts the base. Tighten the filter an additional 1/2 turn. Fill rear transmission case to proper level on dipstick with *Cub Cadet* hydraulic fluid. Start engine and allow it to run for a few minutes. Shut engine off and check for leaks; check oil level in transmission case.

## AIR CLEANER

### Servicing Foam Pre-Cleaner Element

Clean and recoil foam pre-cleaner element at 1-month intervals or every 10 hours, whichever occurs first.



## NOTE

Service more often under dusty conditions.

1. Unhook latches and remove air cleaner cover. (See Figure 37.)
2. Remove foam pre-cleaner element by sliding it up off the paper element.
3. Wash pre-cleaner element in liquid detergent and water. Rinse thoroughly until all traces of detergent are eliminated.
4. Squeeze dry in cloth and allow to air dry.
5. Saturate in engine oil. Squeeze to distribute oil evenly.
6. Wrap in shop towel and squeeze to remove excess oil.
7. Slide over paper element.

Discard used element and replace with new one at least once a year.

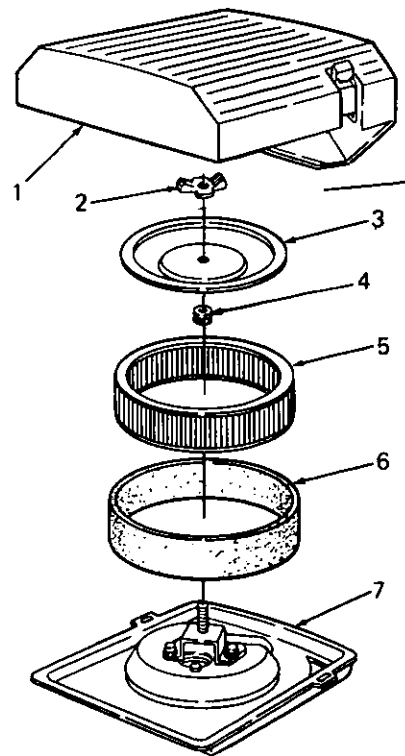

Figure 37. Air Cleaner Assembly

- |                      |                             |
|----------------------|-----------------------------|
| 1. Air Cleaner Cover | 5. Paper Element            |
| 2. Wing Nut          | 6. Foam Pre-Cleaner Element |
| 3. Element Cover     |                             |
| 4. Rubber Grommet    | 7. Air Cleaner Base         |

### SERVICING PAPER ELEMENT

This engine is equipped with a dry-type air cleaner element, which should be checked every 100 operating hours and replaced if dirty. It should be checked and if necessary replaced more often under extremely dirty, dusty conditions. Do not wash element in any liquid or attempt to blow dirt off with air hose as this will puncture filter element. Carefully handle new element — do not use if gasket surfaces are bent or twisted.

1. Unhook latches and remove air cleaner cover. (See Figure 37.)
2. Remove pre-cleaner element, wing nut, cover and paper element.
3. Base must be flat on gasket of carburetor elbow. Replace base if bent or cracked.
4. Gasket surfaces of element must be flat against base and covered to seal effectively.
5. Install new paper element, cover, wing nut and pre-cleaner element.

6. Wing nut must be finger tight — do not over-tighten.
7. Reinstall cover and secure with latches.

Properly cleaned and installed air cleaner elements are the best guarantee to continued long and satisfactory engine life.

### CLEANING ENGINE

This tractor has an air-cooled engine. Air must be able to circulate freely around the engine, shroud and over the fins of the cylinder head and cylinder block. Keep these areas free of accumulated dirt and trash or engine will overheat and result in damaged moving parts. Periodically clean the inside of the side panels and grille insert for adequate cooling.



This machine is designed to cool properly with the engine side panels in place. Operating the machine without panels in place may result in inadequate cooling.

### SPARK PLUGS



### WARNING

To avoid possible injury, be sure engine is off and cool before making any adjustment or repairs.



Remove all dirt from around the spark plugs before removing.

To remove spark plugs, always use a spark plug wrench. Check gap after every 100 hours of operation.

Replace a defective plug with a new plug. Set gap at .040 inch. (See Figure 38.) Tighten plug to 18-22 ft-lbs. See your authorized dealer for the correct replacement plug.

### FUEL FILTER



### WARNING

Do not replace fuel filter when engine is hot.

The engine is equipped with an inline fuel filter. Visually inspect the filter periodically. Replace dirty filter.

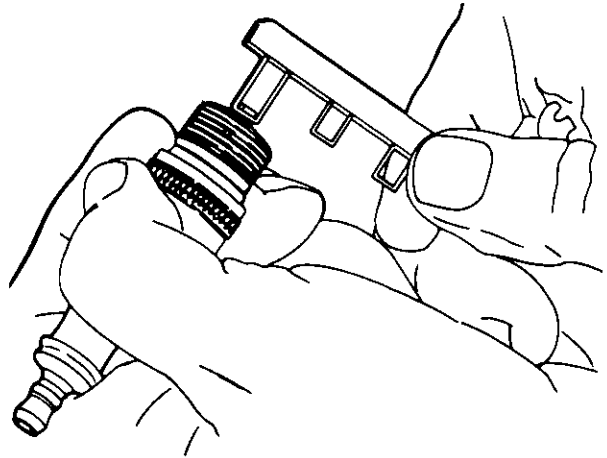

Figure 38

### LIGHTS

Refer to "SPECIFICATIONS" when replacement of headlight or taillight bulb is necessary.



### WARNING

Do not change headlights when hot or when engine is hot.

To replace a headlight, refer to Figure 39 and remove pan head screws and ring that retain the sealed beam units.

To replace a taillight bulb, remove socket from the back of the taillight by rotating socket 1/4 turn. Remove old bulb from socket and install new bulb. Replace socket into taillight and turn to lock in place.

To replace dash indicator lights, remove socket from the back of the dash panel by rotating socket 1/4 turn. Remove old bulb from socket and install new bulb. Replace socket into dash panel and turn to lock in place.

### FUSE

Always use the same capacity fuse for replacement. Refer to "SPECIFICATIONS." If electrical system malfunctions, check the fuse.

To replace a new fuse, pull the old fuse from the fuse housing and install a new fuse. (Refer to Figure 11.)

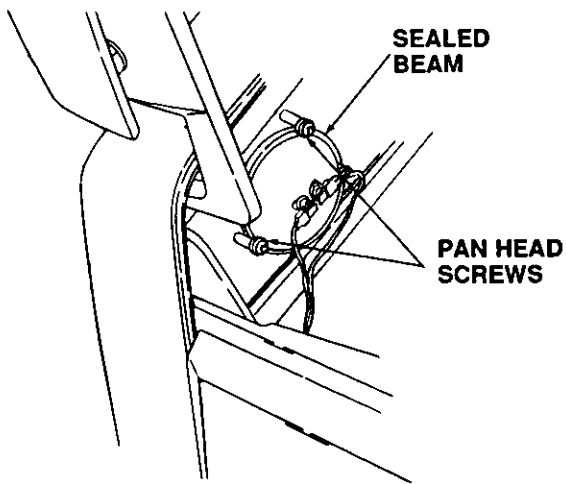

Figure 39

## BATTERY INFORMATION



### WARNING

- A. Battery acid must be handled with great care as contact with it can burn and blister the skin. It is also advisable to wear protective clothing (goggles, rubber gloves and apron) when working with it.\*
- B. Should battery acid accidentally splatter into the eyes or onto the face, rinse the affected area immediately with clean cold water. If there is any further discomfort, seek prompt medical attention.
- C. If acid spills on clothing, first dilute it with clean water, then neutralize with a solution of ammonia/water or baking soda/water.
- D. Since battery acid is corrosive, do not pour it into any sink or drain. Before discarding empty electrolyte containers, rinse them with a neutralizing solution.
- E. NEVER connect or disconnect charger clips to battery while charger is turned on as it can cause sparks.
- F. Keep all lighted materials (cigarettes, matches, lighters) away from the battery as the hydrogen gas generated during charging can be combustible.
- G. As a further precaution, only charge the battery in a well-ventilated area.

\*Always shield eyes and protect skin and clothing when working near batteries.



### DANGER

BATTERIES CONTAIN SULFURIC ACID AND MAY CONTAIN EXPLOSIVE GASES (when electrolyte has been added).

KEEP BATTERIES OUT OF THE REACH OF CHILDREN.

## MAINTENANCE OF BATTERY

1. Check electrolyte level periodically (at least every two weeks). Keep the level to the split rings. Use only distilled water or a good quality drinking water. Never add acid or any other chemicals to the battery after initial activation.
2. The battery should be checked with a hydrometer after every 25 hours of operation. If the specific gravity is less than 1.225, the battery should be recharged. Maximum charge rate is 5 amps.
3. Coat the terminals and exposed wire with a thin coat of grease or petroleum jelly for longer service and protection against corrosion.
4. The battery should be kept clean. Any deposits of acid should be neutralized with baking soda and water. Be careful not to get this solution in the cells.
5. Avoid tipping the battery. Even a "sealed" battery will leak electrolyte when tipped.

## STORAGE OF THE BATTERY

1. When storing battery for extended periods, disconnect battery cables. Removing battery from unit is recommended.
2. Keep the exterior of the battery clean, especially the top. A dirty battery must be stored with a full charge. A dirty battery will discharge itself.
3. Check the battery with a hydrometer. The battery must be stored with a full charge. A discharged battery will freeze.

### Specific Gravity

### Freezing Point

1.265	-71°F
1.250	-62°F
1.200	-16°F
1.150	5°F
1.100	16°F



All batteries discharge during storage.

4. Recharge battery whenever the specific gravity is less than 1.225, before returning to service or every two months, whichever comes first.

### COMMON CAUSES FOR BATTERY FAILURE

1. Overcharging
2. Undercharging
3. Lack of water
4. Loose hold downs and/or corroded connections
5. Excessive loads
6. Battery electrolyte substitutes
7. Freezing of electrolyte



These failures do not constitute warranty.

### BATTERY REMOVAL OR INSTALLATION



#### WARNING

When removing the battery, follow this order of disassembly to prevent your wrench from shorting against the frame.

Battery removal:

1. Remove the Negative cable.
2. Remove the Positive cable.

Battery installation:

1. Attach the Positive cable.
2. Attach the Negative cable.

### JUMP STARTING



#### WARNING

Failure to use this starting procedure could cause sparking, and the gases in either battery could explode.

1. Attach the first jumper cable from the positive terminal of the good battery to the positive terminal of the dead battery.
2. Attach the second jumper cable from the negative terminal of the good battery to the FRAME OF THE UNIT WITH THE DEAD BATTERY.

### TIRES

Keep the pneumatic tires properly inflated. Overinflation will cause operator discomfort. Underinflation will cause short tire life.

Inflate the front and rear tires for normal or heavy load operations as shown in the following table:

Tire Size	Pounds per Square Inch
Front Tires	
16 x 6.50-8	12
Rear Tires	
23 x 10.50-12	10

Always see that the tire valve caps are in place and tightened securely to prevent loss of air and protect the valve core and stem.

Do not overload the tractor tires by mounting equipment on the tractor which exceeds the load capacity of the size of the tires on the tractor.

### MOUNTING TIRES ON THE RIM



#### WARNING

Do not mount a tire unless you have the proper equipment. Do not inflate tire above the recommended pressure. Do not stand in front of or over tire assembly when inflating. Explosive separation of tire and rim can cause injury or death.

After mounting a new or old tire on the rim, inflate it to 20 pounds pressure to seat the tire bead on the rim flange. Then deflate the tire to the correct operating pressure.



#### NOTE

After the first 10 hours of operation, check and retorque the wheel lug nuts (both sides) to 35 ft-lbs. to make sure they have seated properly.

## SECTION V. OFF-SEASON STORAGE

If the machine is to be inoperative for a period longer than 30 days, the following procedures are recommended:



### WARNING

Never store engine with fuel in tank indoors or in poorly ventilated enclosures, where fuel fumes may reach an open flame, spark or pilot light as on a furnace, water heater, clothes dryer, etc.

1. Remove all gasoline from fuel tank to prevent gum deposits from forming on these parts and causing possible malfunction of engine.

Run engine until engine starts to falter, then use choke to continue engine operation until all fuel in tank and carburetor is exhausted. Remove fuel line at tank or carburetor and drain any remaining gasoline from system.



### WARNING

Drain fuel into approved container outdoors, away from open flame.

Fuel left in engine during warm weather deteriorates and will cause serious starting problems.

2. Remove spark plugs and pour one (1) ounce of engine oil through spark plug hole into cylinder. Crank engine several times to distribute oil. Replace spark plugs.
3. Clean the engine and the entire tractor thoroughly.
4. Lubricate all lubrication points.
5. Follow battery storage instructions on page 27.
6. Protect tires and seat from sunlight. Inflate tires at regular intervals.

## SECTION VI. MOWING

### MOWING



#### WARNING

To avoid possible injury, do not allow anyone in the area opposite the discharge chute while mowing. Although the area has been supposedly cleared of foreign objects, small objects may be discharged by the mower.



#### WARNING

Never direct discharge of material toward bystanders or allow anyone near the machine while in operation.

For best results it is recommended that the first two laps should be cut with the discharge thrown towards the center. After the first two laps, reverse the direction to throw the discharge to the outside for the balance of cutting. This will give a better appearance to the lawn.

Do not cut the grass too short, as the mower will tend to scalp the grass. Short grass invites weed growth and yellows quickly in dry weather.

Mowing should be done with the engine at full throttle. Do not mow at high ground speed.

During certain times of the year and under some conditions, the mower may leave streaks of uncut material.

Streaking may occur when attempting to mow heavy weeds and tall grass. Under these conditions it may be necessary to go back over the cut area a second time to get a clean cut.

The following practices will help eliminate streaking:

1. Mow the area more often so the grass doesn't get too tall and heavy.
2. Operate the tractor at full throttle and lower forward speeds.
3. Keep the blades sharp and replace blades when worn.
4. Follow the mowing procedure shown in Figure 40.

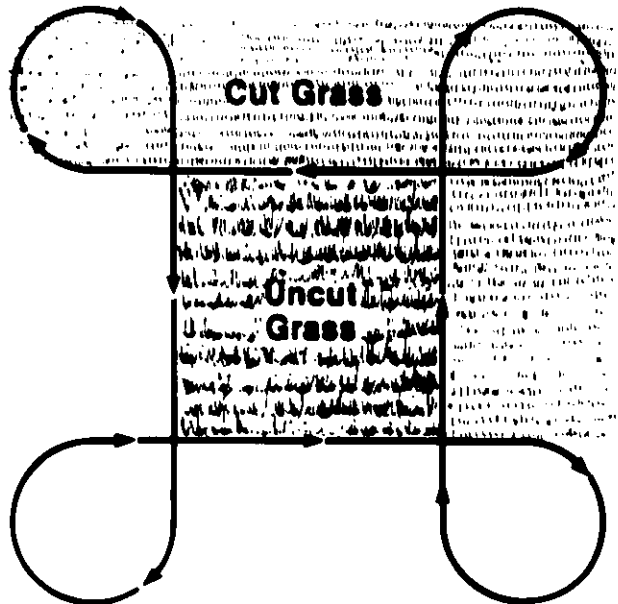

Figure 40

## OPTIONAL EQUIPMENT AND ACCESSORIES

When you purchased your tractor, you probably had it completely equipped for your particular needs at the time. However, later you may wish to obtain optional equipment or accessories. These items and other allied equipment can be purchased from, and installed by, your authorized dealer.

The tractor is used for so many different types of work, and because it is called on to operate under so many different conditions, a variety of equipment is available to adapt it to the requirements of the user. **Refer to attachment guide for a complete description of equipment and required components that can be utilized with your tractor.**

## MAINTENANCE CHART

Operation to be performed	Before each use	10 hours or once a month	30 hours three times a season	50 hours or twice a season	100 hours or yearly	Before storage
Clean grille insert, engine inlet air screen and side panels		More often under dirty conditions X				
Check engine oil level	X					
Fill fuel tank	X					
Change engine oil & oil filter	After first 5 hours				More often under dirty conditions X	
Check transmission oil level	X					
Replace transmission oil filter		After first 10 hours X		After first 50 hours X	Every 100 hours there-after	
Reoil & clean foam air precleaner		X				
Check battery electrolyte level		X				
Grease front axle pivot bolt		X				
Lubricate steering knuckles (2) & steering arm		X				
Retorque rear wheel lug nuts		After first 10 hours X				
Lubricate brake shaft			X			
Grease lift shaft			X			
Clean cooling fins & external surfaces			X			
Service air cleaner paper cartridge					More often under dirty conditions	
Check spark plugs					X	X
Lubricate speed control linkage cam plates					X	
Lubricate drive shaft					X	
Steering gear housing (1863 only)					X	
Grease front wheel bearings			X			X
Drain fuel						X
Pivot bar adjustment bolts				X		



Maintenance information for operational equipment may be found in the manual which is included with the specific piece of optional equipment.



# TROUBLE SHOOTING

**Possible Cause**

**Possible Remedy**

## HARD TO START

No gasoline in fuel tank or carburetor .....	Fill the tank with gasoline; open the fuel shut-off valves. Check the fuel line, carburetor and fuel filter.
Fuel line or carburetor clogged .....	Clean the fuel line and carburetor with commercial carburetor cleaner.
Fuel filter plugged .....	Replace.
Water in gasoline .....	Drain the fuel tank and carburetor. Use new fuel and dry the spark plugs.
Choked improperly. Flooded engine .....	Follow the starting instructions.
Defective ignition or loose wiring .....	Check the wiring, spark plugs or fuse.
Defective battery .....	Check and service. Refer to <b>"BATTERY."</b>
Spark plug dirty or improper gap .....	Clean, adjust the gap to .040-inch or replace the plug.

## ENGINE OPERATES IRREGULARLY OR KNOCKS

Engine incorrectly timed .....	*
Spark plug dirty; wrong gap or wrong type .....	Clean, reset the gap or replace.
Poor or weak spark .....	Check the spark plugs and wiring.*
Carburetor setting incorrect .....	Adjust. Refer to <b>"ADJUSTMENTS"</b>
Poor grade fuel or water in fuel .....	Drain and use a good grade of clean fuel.
Engine overheating .....	Refer to <b>"MAINTENANCE."</b>
Engine valves at fault .....	*
Engine smokes .....	Adjust the carburetor.*
Oil level rises due to gasoline in crankcase .....	*
Air filter becomes oil and fuel soaked .....	*
Engine leaks oil .....	*
Misfiring .....	*
Other engine problems .....	*
Excessive oil in air cleaner .....	Be sure that oil dipstick is fully seated and all excess oil is squeezed out of pre-cleaner foam element.

## PTO CLUTCH WILL NOT ENGAGE

Low or zero voltage .....	Check battery. Charge or replace. Check charging system. Check for worn or broken wiring or connections. Check clutch coil resistance. Check switch.
Rotor/armature air gap too large .....	Rotor/armature worn. Adjust air gap.

**\*See your authorized dealer.**

# TROUBLE SHOOTING

## Possible Cause

## Possible Remedy

### LACK OF POWER

Air cleaner clogged .....	Service the air cleaner element. Refer to "MAINTENANCE."
Engine overload .....	Reduce the load.
Engine overheated .....	Make sure air intake screen, shrouding, engine fins, side panels and grille insert are free of accumulated dirt and trash. Refer to "MAINTENANCE."
Fuel tank air vent clogged .....	Open the vent in the cap.
Air leakage between carburetor and engine .....	Remove air cleaner. Tighten the carburetor and manifold mounting nuts. Replace as indicated in "MAINTENANCE."
Incorrect timing or faulty ignition .....	*
Brake drags .....	Adjust the brake. Refer to "ADJUSTMENTS."
Insufficient cool air, dirty air intake screen, shroud, cooling fins, side panels or dirty grille insert ..	Keep the air intake area, side panels, grille insert and cooling fins clean; refer to "MAINTENANCE."
Oil level incorrect .....	Engine oil level must not be over the "FULL" mark or below the "LOW" mark. Refer to "MAINTENANCE."

\*See your authorized dealer.

## LUBRICATION TABLE

Point of Lubrication	Check at Hours	Change at Hours	Capacity	Anticipated Air Temperature	
				Above +32°F	Below +32°F
Engine crankcase	Check before each use	100	Approx. 4 pints	<i>Cub Cadet</i> Engine Oil SAE 10W30 or 10W40	<i>Cub Cadet</i> Engine Oil SAE 5W20 or 5W30
Hydro-drive unit mounted on transmission case with filter	Check before each use	Add as needed	Approx. 14 pints	<i>Cub Cadet</i> Hydraulic Transmission Fluid <b>NOTE:</b> <i>Cub Cadet</i> hydraulic transmission fluid meets IH B-6 specifications. If fluid is used that does not meet these requirements, <i>Cub Cadet</i> will not be responsible for substandard performance. Failures due to use of improper fluid are not covered by warranty. For maximum protection, use <i>Cub Cadet</i> Hydraulic Transmission Fluid.	
Steering knuckles & front axle pivot bolt	10			Use 251H EP grease or equivalent No.2 multi-purpose lithium grease and apply two or three strokes or sufficient grease to flush out old grease and dirt.	
Front wheel bearings	30			Two strokes of the lubricator using 251H EP grease or equivalent No. 2 multi-purpose lithium grease.	
Lift shaft	30			Two strokes of the lubricator using 251H EP grease or equivalent No. 2 multi-purpose lithium grease.	
Drive shaft	100			CV-Joint grease or Polyrex grease Part No. 737-3023 -- use sufficient amount to make rubber boot coupling swell.	
Steering gear housing (1863 only)	100			Two strokes of the lubricator using 251H EP grease or equivalent No. 2 multi-purpose lithium grease.	

# LUBRICATION GUIDE



## WARNING

The life of any machine depends upon the care it is given. Proper lubrication is a very important part of that care.

Be certain that all lubrication fittings are assembled in place, using the lubrication illustrations as a guide.

Always lubricate the tractor thoroughly before taking it to the field. Use a pressure lubricating gun.

Be sure all fittings are free from dirt and paint so the lubricant is certain to enter the bearing.

Always force the lubricant through the full length of each bearing until it emerges at the end, carrying with it the worn lubricant and any dirt that may have entered the bearing.

Miscellaneous working parts not provided with lubrication fittings should be oiled daily with a good grade of lubricating oil.

Lubricant is cheap. Use plenty of it. Worn parts can be expensive to replace.

Keep your supply of lubricating oil and grease stored in clean containers, and covered to protect from dust and dirt.

Keep the lubricating gun nozzle clean and wipe dirt from grease fittings before lubricating.

The symbols in the illustration indicate the method of application and the hourly intervals to apply the lubricant.

Use a pressure lubricating gun and apply 251H EP grease (or equivalent No. 2 multi-purpose lithium grease) sufficient to flush out the old grease and dirt. Lubricate at hourly intervals indicated on symbols.



Dipstick, use to check engine oil before each use.

### —Before Each Use

1. Engine filler cap and dipstick

Check the oil (with the engine stopped) and add sufficient new oil to bring it to the "FULL" mark on the dipstick. Do not overfill. Do not operate the engine if the oil level is below the "LOW" mark on the dipstick.

### —After Every 10 Hours of Operation

2. Steering knuckles (2)  
(Both sides)

Use 251H EP grease or equivalent No. 2 multi-purpose lithium grease and apply sufficient grease to flush out old grease and dirt.

3. Transmission oil filter

**NOTE:** After the first 10 hours only, remove the transmission oil filter and replace with a new filter. Refer to "MAINTENANCE." Change the transmission oil filter after 50 hours and every 100 hours of operation thereafter.

4. Front axle pivot bolt  
(Right side)

Use 251H EP grease or equivalent No. 2 multi-purpose lithium grease and apply sufficient grease to flush out old grease and dirt.

**NOTE:** It may be necessary to rotate the front axle to reach the grease fitting.

# LUBRICATION GUIDE

## —After Every 30 Hours of Operation

- 5. Transmission oil level and fill tube

Check the oil with the engine stopped. Keep the lubricant up to "FULL" mark on dipstick.

**NOTE:** Transmission oil level and fill tube also services the following:

1. Hydrostatic transmission
2. Rear axle
3. Hydraulic lift system
4. Power steering (1864 only)

- 6. Front wheel bearings

Two or three strokes minimum of the lubricator using 251H EP grease or equivalent No. 2 multi-purpose lithium grease.

- 7. Lift shaft

Two or three strokes minimum of the lubricator using 251H EP grease or equivalent No. 2 multi-purpose lithium grease.

- 8. Transmission oil filter

## —After Every 50 Hours of Operation

**NOTE:** After the first 50 hours only, remove the transmission oil filter and replace with a new filter. Refer to "MAINTENANCE." Change the transmission oil filter every 100 hours of operation thereafter.

## —Every 100 Hours of Operation

- 9. Transmission oil filter

Change the transmission oil filter and replace with a new filter. Refer to "MAINTENANCE."

- 10. Engine oil drain plug and oil filter

While the engine oil is warm, remove the drain plug and oil filter, and drain all of the oil from the crankcase. Replace the drain plug. Refer to "MAINTENANCE," "FILLING THE CRANKCASE" and "OIL FILTER" for proper oil filling procedure. Refer to "LUBRICATION TABLE" for the proper quantity and viscosity to use.

## Speed Control Linkage

- 11. Cam plates

Once a year, apply a small amount of 251H EP grease or equivalent No. 2 multi-purpose lithium grease in the slots.

- 12. Drive shaft

CV joint grease or Polyrex grease Part No. 737-3023 – use a sufficient amount of clean grease until the rubber boot coupling starts to swell.

- 13. Steering gear housing (1863 only)

Every 100 hours or yearly, use 251H EP grease or equivalent No. 2 multi-purpose lithium grease. Apply two strokes with lubricator.

## Miscellaneous

Brake pedal shaft

Lubricate the brake pedal shaft and linkage with eight or ten drops of engine oil.

Alignment couplings

Use 251H EP grease or equivalent No. 2 multi-purpose lithium grease.



Lubrication information for optional equipment may be found in the manual which is included with the specific piece of optional equipment.

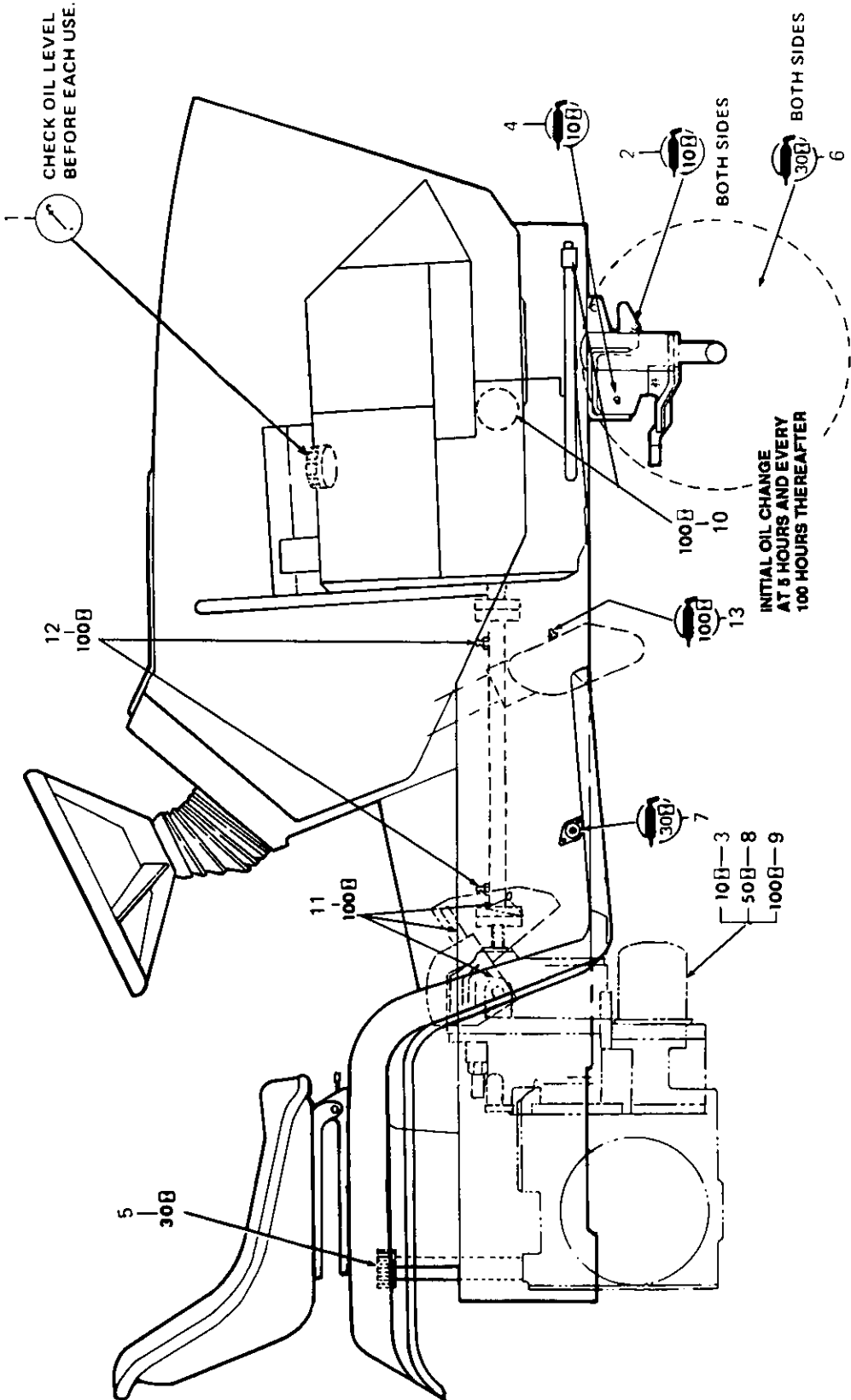

MODEL 1863

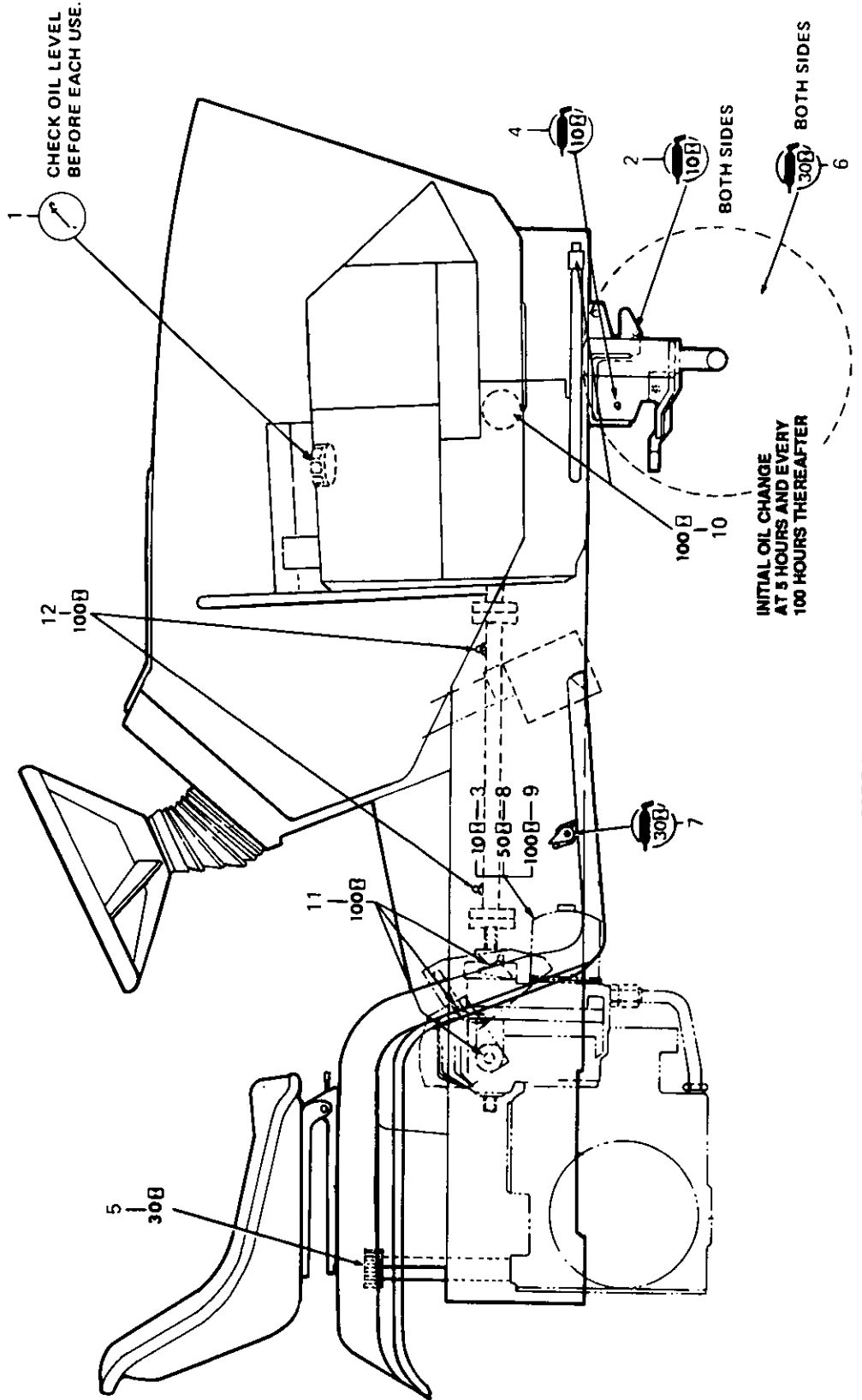

MODEL 1864

# SPECIFICATIONS

	1863 and 1864
<b>CAPACITIES</b>	
Fuel tank .....	5 gallons
Crankcase (approximately) .....	4 pints
Transmission case with hydro-drive unit mounted (approximately) .....	7 qts.
<b>HYDROSTATIC DRIVE</b>	
Speed: Forward .....	0 to 7.5 mph
Reverse .....	0 to 4 mph
<b>ENGINE</b>	
Make and model .....	Kohler Command
Horsepower .....	18 HP
Cylinders .....	2
Bore .....	3.03 in.
Stroke .....	2.64 in.
Displacement (cubic inches) .....	38.1
Engine speed (governed)	
Low speed .....	1200 RPM
High idle speed	
(no load) .....	3600 RPM
(full load) .....	3350 RPM
Ignition .....	Battery
Spark plug gap ( <i>Cub Cadet</i> No. 759-3336) .....	.040 in. gap
<b>ELECTRICAL SYSTEM</b>	
System voltage .....	12 volt neg. ground
Battery .....	725-3174
Alternator .....	15 amp
Fuse (auto type) .....	20 amp
Headlight .....	725-0222
Taillight .....	Lamp No. 194
<b>BRAKES</b> .....	Dual disc, external
<b>TIRE SIZES</b>	
Front .....	16 x 6.50-8
Rear .....	23 x 10.50-12
<b>DIMENSIONS</b>	
Tread:	
Front with 16 x 6.50-8 tires .....	29.00 in.
Rear with 23 x 10.50-12 tires .....	27.00 in.
Wheelbase .....	45.5 in.
Length, over-all .....	72.00 in.
Width, over-all .....	37.75 in.
Height, over-all (to top of steering wheel) .....	44.00 in.
Ground clearance .....	6.00 in.
Turning radius .....	25.0 in.

Specifications are subject to change without notice.



# SLOPE GAUGE

(Keep this sheet in a safe place for future reference.)

USE THIS SHEET AS A GUIDE TO DETERMINE SLOPES WHERE YOU MAY NOT OPERATE SAFELY.

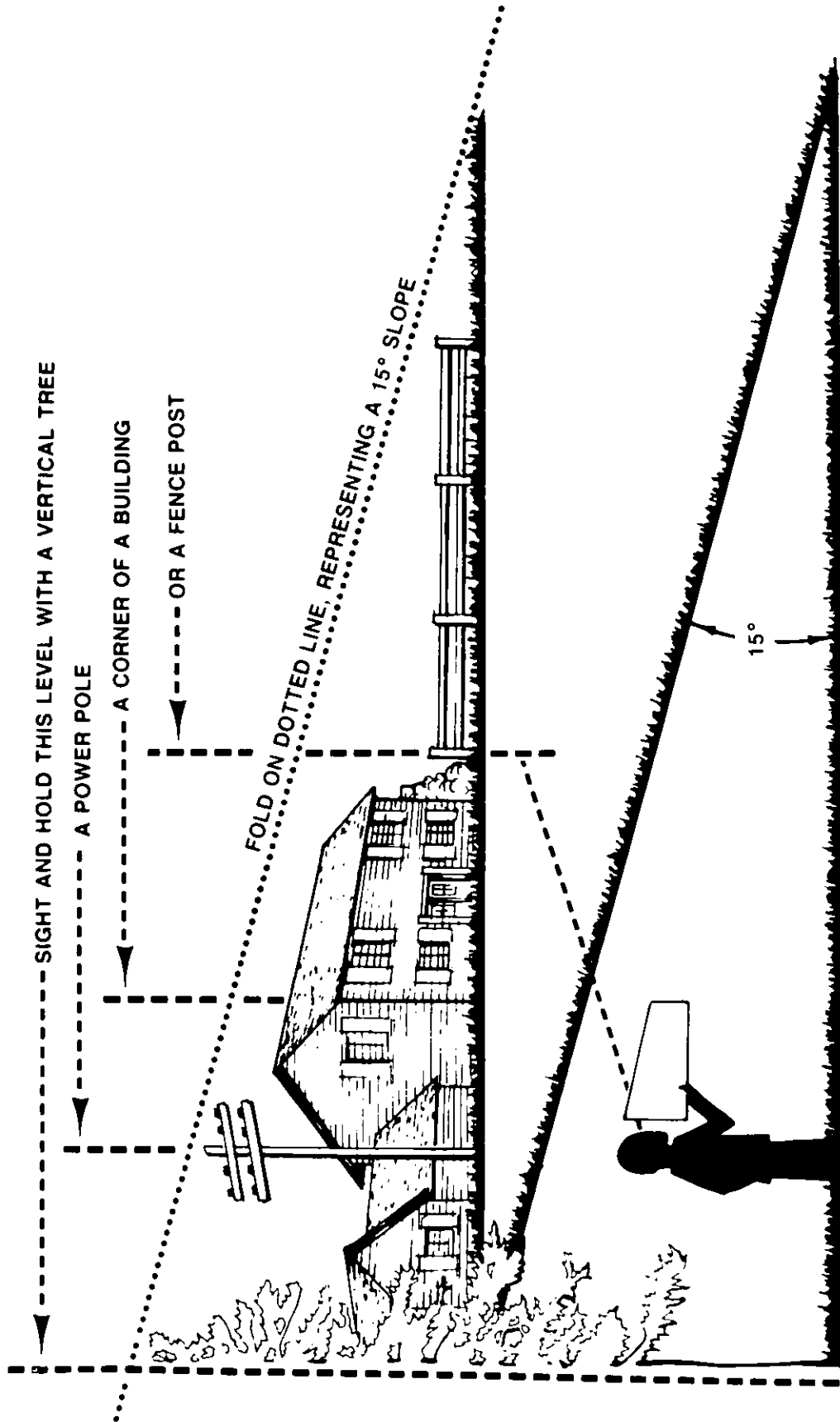







Do not mow on inclines with a slope in excess of 15 degrees (a rise of approximately 2½ feet every 10 feet). A riding mower could overturn and cause serious injury. If operating a walk-behind mower on such a slope, it is extremely difficult to maintain your footing and you could slip, resulting in serious injury.

Operate RIDING mowers up and down slopes, never across the face of slopes.

Operate WALK-BEHIND mowers across the face of slopes, never up and down slopes.

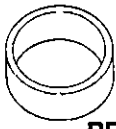

# MAINTENANCE PARTS CHART

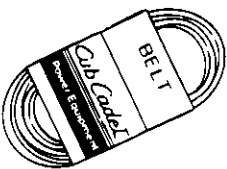
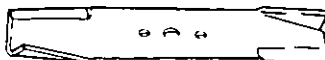
MODELS 1863 AND 1864		GARDEN TRACTOR 18 HP KOHLER			
<b>ENGINE OIL</b> 		<b>Engine Oil Requirements approx. . . . 4 pints</b> Cub Cadet engine oil Ambient temperature viscosity (Grade SF or SG) Above +32°F            SAE 10W30 or 10W40 Below +32°F            SAE 5W20 or 5W30		<b>Part No.</b>  737-3030A (10W30) 737-3049 (5W30)	
<b>AIR FILTER</b>  <b>CARTRIDGE</b>   <b>FOAM PRE-CLEANER</b>		<b>Air Filter Requirements</b> Clean air filter per instructions in your owner's manual . . . . . under maintenance air cleaner.		<b>Part No.</b>  Cartridge KH-47-083-03  Foam Pre-cleaner KH-24-083-02	
<b>ENGINE OIL FILTER</b> 		<b>Engine Oil Filter Requirements</b> Change every 100 hours		<b>Part No.</b>  KH-12-050-08	
<b>SPARK PLUG</b> 		<b>Gap Requirements</b> .040 inch gap		<b>Part No.</b>  759-3336	
<b>HYDRAULIC OIL FILTER</b> 		<b>Oil Filter Requirements</b> Change every 100 hours		<b>Part No.</b>  723-3014	
<b>HYDRAULIC OIL</b> 		<b>Hydraulic Oil Requirements approx. . . . 7 qts</b> Check before each use  <div style="text-align: right;">1 quart 5 quarts</div>		<b>Part No.</b>  737-3025 737-3026	
<b>BELTS</b> 		<b>Deck Blade Belt</b>		<b>Tractor to Deck Belt</b>	
		<b>Model</b>	<b>Part No.</b>	<b>Model</b>	<b>Part No.</b>
		42" Deck	754-3050	42" Deck	754-3048
		44" Deck	754-3004	44" Deck	754-3023
		46" Deck	754-3039	46" Deck	754-3048
		48" Deck	754-3053	48" Deck	754-3001
		54" Deck	754-3045	54" Deck	754-3001
<b>BLADES</b> 		<b>Original Equipment Blade</b>		<b>Hard Coated Blade</b>	
		<b>Size</b>	<b>Part No.</b>	<b>Size</b>	<b>Part No.</b>
		42"	742-3018 (2)	44"	759-3402 (3)
		44"	742-3002 (3)		
		46"	742-3015 Center (1) 742-3016 Outer (2)		
		48"	742-3019 (3)	48"	759-3677 (3)
		54"	742-3013 (3)	54"	759-3597 (3)
<b>HI-Lift Blade</b>		<b>Bagging Blade</b>		<b>Hard Coated Bagging Blade</b>	
<b>Size</b>	<b>Part No.</b>	<b>Size</b>	<b>Part No.</b>	<b>Size</b>	<b>Part No.</b>
48"	742-3025 (3)	42"	742-3017 (2)	46"	759-3398 Center (1)
		46"	742-3010 Center (1) 742-3011 Outer (2)		759-3397 Outer (2)

