

**Cub Cadet**

**Power Equipment**

# Owner's Manual

---



**21" MULCHING  
SELF-PROPELLED  
ROTARY MOWER**

**Model Number  
148  
(148C123)**

**Important:**

**Read Safety Rules and Instructions Carefully**

Thank you for purchasing an American-built product.

**WARNING:** This unit is equipped with an internal combustion engine and should not be used on or near any unimproved forest-covered, brush-covered or grass-covered land unless the engine's exhaust system is equipped with a spark arrester meeting applicable local or state laws (if any). If a spark arrester is used, it should be maintained in effective working order by the operator.  
In the State of California the above is required by law (Section 4442 of the California Public Resources Code). Other states may have similar laws. Federal laws apply on federal lands. A spark arrester for the muffler is available through your nearest authorized service dealer.

**CUB CADET CORPORATION • P.O. BOX 368023 • CLEVELAND, OHIO 44136-9723**

# IMPORTANT

## SAFE OPERATION PRACTICES



THIS SYMBOL POINTS OUT IMPORTANT SAFETY INSTRUCTIONS WHICH, IF NOT FOLLOWED, COULD ENDANGER THE PERSONAL SAFETY AND/OR PROPERTY OF YOURSELF AND OTHERS. READ AND FOLLOW ALL INSTRUCTIONS IN THIS MANUAL BEFORE ATTEMPTING TO OPERATE YOUR LAWN MOWER. FAILURE TO COMPLY WITH THESE INSTRUCTIONS MAY RESULT IN PERSONAL INJURY. WHEN YOU SEE THIS SYMBOL—  **HEED ITS WARNING.**



### DANGER:

Your lawn mower was built to be operated according to the rules for safe operation in this manual. As with any type of power equipment, carelessness or error on the part of the operator can result in serious injury. If you violate any of these rules, you may cause serious injury to yourself or others.

### TRAINING



1. Read this owner's guide carefully in its entirety before attempting to assemble or operate this machine. Be completely familiar with the controls and the proper use of this machine before operating it. Keep this manual in a safe place for future and regular reference and for ordering replacement parts.
2. Your rotary mower is a precision piece of power equipment, not a plaything. Therefore, exercise extreme caution at all times. Your unit has been designed to perform one job: to mow grass. Do not use it for any other purpose.
3. Never allow children under 14 years old to operate a power mower. Children 14 years old and over should only operate mower under close parental supervision. Only persons well acquainted with these rules of safe operation should be allowed to use your mower.
4. Keep the area of operation clear of all persons, particularly small children and pets. Stop engine when they are in the vicinity of your mower to help prevent blade contact or thrown object injury. Although the area of operation should be completely cleared of foreign objects, an object may have been overlooked and could be accidentally thrown by the mower in any direction and cause serious personal injury to the operator or any others allowed in the area.

### PREPARATION



1. Thoroughly inspect the area where the equipment is to be used. Remove all stones, sticks, wire, bones and other foreign objects which could be picked up and thrown by the mower in any direction and cause serious personal injury to the operator or any others allowed in the area. Plan your mowing pattern to avoid discharge of material toward roads, sidewalks, bystanders and the like.
2. Always wear safety glasses or eye shields during operation or while performing an adjustment or repair, to protect eyes from foreign objects that may be thrown from the machine in any direction.
3. Wear sturdy, rough-soled work shoes and close-fitting slacks and shirts. Shirts and pants that cover the arms and legs and steel-toed shoes are recommended. Do not wear loose fitting clothes or jewelry. They can be caught in moving parts. Never operate a unit in bare feet, sandals, or sneakers.
4. Before working with gasoline, extinguish all cigarettes, cigars, pipes and other sources of ignition. Check the fuel level before starting the engine. Gasoline is an extremely flammable fuel. Do not fill the gasoline tank indoors, while the engine is running, or until engine has been allowed to cool for at least two minutes after running. Replace gasoline cap securely and wipe off any spilled gasoline before starting the engine as it may cause a fire or explosion.
5. Disengage the self-propelled mechanism or drive clutch on units so equipped before starting the engine.
6. The blade control handle is a safety device. Never attempt to bypass its operation. Doing so makes the safety device inoperative and may result in personal injury through contact with the rotating blade. The blade control handle must operate easily in both directions and automatically return to the disengaged position when released.
7. Never attempt to make a wheel or cutting height adjustment while the engine is running.
8. Never operate the mower in wet grass. Always be sure of your footing. A slip and fall can cause serious personal injury. Keep a firm hold on the handle and walk, never run. Mow only in daylight or in good artificial light.

9. For your safety, use the slope gauge included as part of this manual to measure slopes before operating this unit on a sloped or hilly area. If the slope is greater than 15° as shown on the slope gauge, do not operate this unit on that area or serious injury could result.

### OPERATION



1. Do not change the engine governor settings or overspeed the engine. Excessive engine speeds are dangerous.
2. Do not put hands or feet near or under rotating parts. Keep clear of the discharge opening at all times as the rotating blade can cause injury.
3. Stop the blade when crossing gravel drives, walks or roads.
4. After striking a foreign object, stop the engine, remove the wire from the spark plug, and thoroughly inspect the mower for any damage. Repair the damage before restarting and operating the mower.
5. If the equipment should start to vibrate abnormally, stop the engine and check immediately for the cause. Vibration is generally a warning of trouble.
6. Shut the engine off and wait until the blade comes to a complete stop before removing the grass catcher or unclogging the chute. The cutting blade continues to rotate for a few seconds after the engine is shut off. Never place any part of the body in the blade area until you are sure the blade has stopped rotating.
7. Before cleaning, repairing or inspecting, make certain the blade and all moving parts have stopped. Disconnect the spark plug wire, and keep the wire away from the spark plug to prevent accidental starting.
8. Do not run the engine indoors.
9. Never cut grass by pulling mower toward you. Mow across the face of slopes, never up-and-down. Exercise extreme caution when changing direction on slopes. Do not mow excessively steep slopes. Always be sure of your footing. A slip and fall can cause serious personal injury.
10. Never operate mower without proper guards, plates or other safety protective devices in place.
11. Muffler and engine become hot and can cause a burn. Do not touch.

### MAINTENANCE AND STORAGE



1. Check the blade and engine mounting bolts at frequent intervals for proper tightness. Also visually inspect blade for damage (e.g. bent, cracked). Replace with blade which meets original equipment specifications.
2. Keep all nuts, bolts, and screws tight to be sure the equipment is in safe working condition.
3. Never store the mower with gasoline in the tank or gas containers inside of a building where fumes may reach an open flame or spark (e.g. gas hot water heater). Allow the engine to cool before storing in any enclosure.
4. To reduce fire hazard, keep the engine free of grass, leaves and excessive oil.
5. Check the grass catcher bag frequently for wear or deterioration. Replace a worn or damaged bag immediately. For safety protection, replace only with new bag meeting original equipment specifications.

# SET-UP INSTRUCTIONS

**IMPORTANT:** This unit is shipped **WITHOUT GASOLINE or OIL.** Be certain to service engine with gasoline and oil as instructed in the separate engine manual before operating your mower.

**NOTE:** Reference to right or left hand side of the mower is observed from the operating position.

## HOW TO SET-UP YOUR LAWN MOWER

Refer to Illustration Below

1. Remove carton inserts (if any) and the side discharge chute which is loose in the carton. Lift the mower from the carton, or cut the corners of the carton and roll the mower out.
2. The owner's manual is in a plastic bag which is wrapped around the upper handle. Cut and remove any plastic. Remove any cardboard pieces which may be between the upper and lower handles for shipping purposes.
3. Disconnect the spark plug wire and move it away from the spark plug.
4. Pull up and back on the upper handle to raise the handle into the operating position. Make certain the lower handle is seated securely into the handle mounting brackets. Tighten the hand knobs on each side of the handle.

**NOTE:** Your mower is shipped with the handle in the higher height position. If you wish to lower the height of the handle, refer to the Adjustment Section at this time.

5. Remove the hairpin clips from the outer hole in the weld pins on the handle mounting brackets. Place the hairpin clips in the inner hole.
6. The rope guide and wing nut are attached to the starter rope, on top of the engine. Remove the wing nut from rope guide. Remove the rope guide from the starter rope.
7. With the spark plug wire disconnected and grounded, hold the blade control handle against the upper handle, and pull the starter rope out of the engine. Hold the rope guide as shown so the opening in the rope guide is toward the front of mower. Slip the rope guide around the starter rope and into the right side of upper handle using the hole shown. Secure using the wing nut.
8. Make certain all nuts and bolts are tightened securely.

Your mower has been shipped as a mulcher. To discharge grass to the side, proceed with step 9.

9. **To convert your mower from a mulcher to a side discharge mower,** lift the mulching plug. Slide the two hooks on the side discharge deflector under the hinge pin on the mulching plug assembly. Lower the mulching plug.

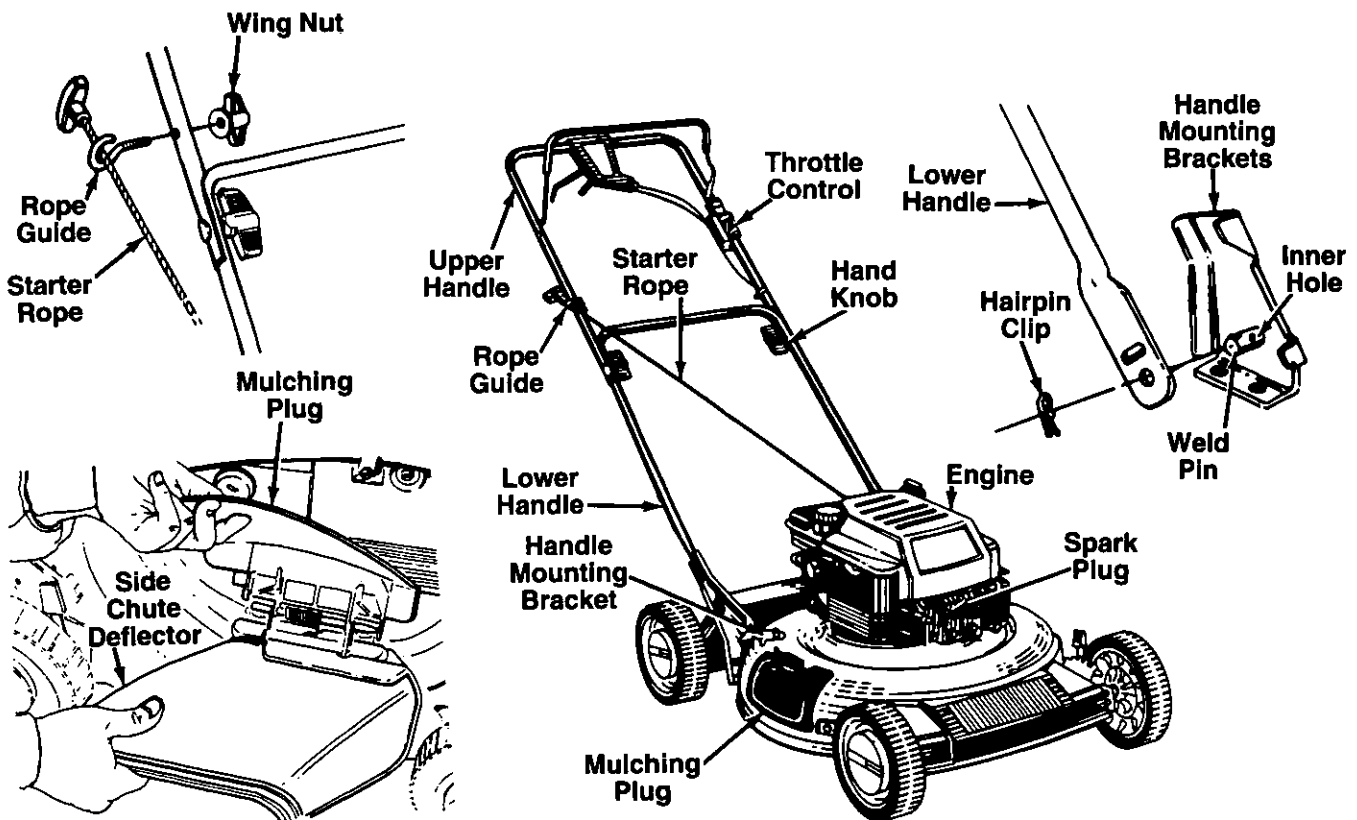

---

## CONTROLS

---

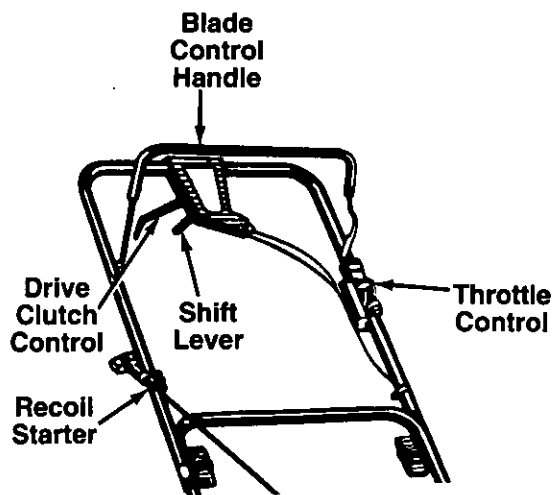

FIGURE 2.

### BLADE CONTROL HANDLE



**WARNING:** This control mechanism is a safety device. Never attempt to bypass its operations.

The blade control handle is located on the upper handle of the mower. See figure 2. The blade control handle must be depressed in order to operate the unit. Release the blade control handle to stop the engine and blade.



**WARNING:** The blade will be rotating whenever the engine is running.

### THROTTLE CONTROL

The throttle control is located on the left side of the upper handle. It is used to regulate the engine speed.



**WARNING:** The throttle control cannot be used to stop the engine.

### RECOIL STARTER

The recoil starter handle is attached to the handle. See figure 2. Stand behind the unit in the operating position to start the unit.

### DRIVE CLUTCH CONTROL

Squeezing the drive clutch control engages the drive mechanism to the rear wheels. Releasing the clutch control stops the rear wheels from driving. Release the drive clutch control to slow down when negotiating an obstacle, making a turn or stopping. See figure 2.

### SHIFT LEVER

The six speed shift lever is located on the drive clutch control housing on the upper handle. See figure 2. This lever is used to select the operating speed of the mower. Release the drive clutch control when changing speeds.

**IMPORTANT:** Move the shift lever **ONLY** when the engine is running. Shifting the speeds with the engine off can cause damage to the unit.

---

## OPERATION

---



FIGURE 3.

Keep hands and feet away from the chute area on cutting deck. See figure 3.

The operation of any lawn mower can result in foreign objects being thrown into the eyes, which can result in severe eye damage. **Always wear safety glasses or eye shields. We recommend wide vision safety mask for over spectacles or standard safety glasses.**



**NOTE:** For best results raise the cutting position until it is determined which height is best for your lawn. See cutting height adjustment section.

### GAS AND OIL FILL-UP

Service the engine with gasoline and oil as instructed in the separate engine manual. **Read instructions carefully.**



**WARNING:** Never fill fuel tank indoors, with engine running or until the engine has been allowed to cool for at least two minutes after running.

## BEFORE STARTING

1. Before each use, check for proper drive clutch operation by performing the following before starting the engine:

With the drive clutch control released, push mower forward. It should move freely. Pull mower backward. It should move with only a small amount of resistance.

If it does not and the rear wheels tend to lock up, the clutch may not be releasing completely. Do not start the engine until corrections have been made. Check the control cable for severe bend kinks and binding, or grass build-up around the belt. Correct and adjust as required. Refer to instructions under "Drive Clutch Control Adjustment" in Adjustment Section for loosening the drive belt.

2. Attach spark plug wire to spark plug. Make certain the metal loop on the end of the spark plug wire (inside the rubber boot) is fastened securely over the metal tip on the spark plug. See figure 4.

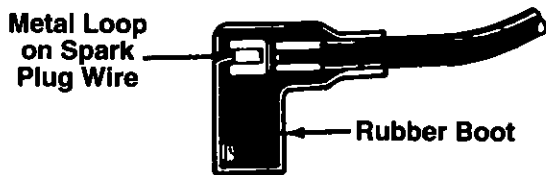

FIGURE 4.

## TO START ENGINE AND ENGAGE BLADE

**IMPORTANT:** Move the shift lever only when the engine is running. Shifting the speeds with the engine off can cause damage to the unit. Disengage the drive clutch control when shifting speeds.



**WARNING:** When starting the unit for the first time, place mower in first speed (slow) position. Face the mower against a solid object such as a wall, fence, etc. Start the unit, and if it shows any signs of motion with the drive clutch control disengaged, shut the engine off immediately. Make certain the drive clutch control is adjusted so the drive belt is as loose as possible. Refer to the Adjustment Section.

1. Move the throttle control lever to all the way forward.
2. Prime engine as instructed in the engine manual.

3. Standing behind the unit, depress the blade control handle and hold it against the upper handle. Make certain drive clutch control handle is released.
4. Grasp starter handle and pull rope out slowly until engine reaches start of compression cycle (rope will pull slightly harder at this point). Let the rope rewind slowly.
5. Pull rope with a rapid, continuous, full arm stroke. Keep a firm grip on start handle. Return it slowly to the rope guide.
6. After engine starts, move throttle control to FAST or desired engine speed.

**NOTE:** If any problems are encountered, refer to the Trouble Shooting Guide on page 10.

## TO STOP ENGINE AND BLADE

1. Release the blade control handle to stop the engine and blade.



**WARNING:** The blade continues to rotate for a few seconds after the engine is shut off.

2. Disconnect the spark plug wire and ground it against the engine to prevent accidental starting while equipment is unattended.

## USING YOUR ROTARY MOWER

Be sure that lawn is clear of stones, sticks, wire, or other objects which could damage lawn mower or engine. Such objects could be accidentally thrown by the mower in any direction and cause serious personal injury to the operator and others.

For the best results, do not cut wet grass because it tends to stick to the underside of the mower, preventing proper discharge of grass clippings, and could cause you to slip and fall. New grass, thick grass or wet grass may require a narrower cut. Speed of the mower should be adjusted to the condition of the lawn.

When using the side discharge mower, the best mowing pattern is one that allows the clippings to discharge towards the uncut part of the lawn. This permits recutting of the clippings to further pulverize them. When cutting high weeds, discharge towards cut portion, then recut at right angles to first direction.

**For a healthier lawn, always cut off one-third or less of the total length of the grass.** Lawn should be cut in the fall as long as there is growth.

This mower is designed to be operated at full throttle to give you the best cut and do the most effective job of mowing.



**WARNING:** If you strike a foreign object, stop the engine. Remove wire from spark plug, thoroughly inspect the mower for any damage, and repair the damage before restarting and operating the mower. Extensive vibration of the mower during operation is an indication of damage. The unit should be promptly inspected and repaired.

## ADJUSTMENTS



**WARNING:** Do not at any time make any adjustment to lawn mower without first stopping engine and disconnecting spark plug wire.

### CUTTING HEIGHT ADJUSTMENT

The height adjustment handles for the wheels are located on the left side of the deck. The handles may be placed in one of nine cutting height positions. See figure 5.

For rough or uneven lawns, move the height adjustment handles to positions which will give a higher cutting height. Both front and rear handles must be placed in the same relative position.

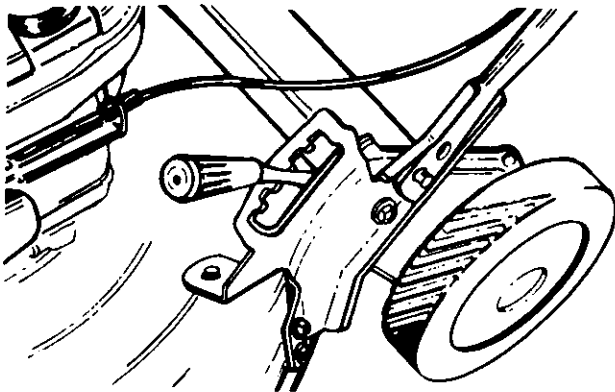

FIGURE 5.

### HANDLE HEIGHT ADJUSTMENT

Your mower is shipped with the handle in the higher height position. To lower the handle height, proceed as follows.

1. Remove the starter rope from the rope guide.
2. Remove the upper handle by removing the hand knobs and carriage bolts. Lay the upper handle out of the way, being careful not to bend or kink the cables.

3. Remove the hairpin clips from the weld pins on the handle brackets. Press outward on the legs of the lower handle, and remove it from the mower.
4. Turn the lower handle around so the flat on the bottom is facing upward as shown in figure 6. Reassemble, placing the bottom holes in the handle over the weld pins in the handle mounting bracket.
5. Reassemble the upper handle.
6. Place the hairpin clips in the inner holes in the weld pins and attach the starter rope as instructed in the Assembly Instructions.

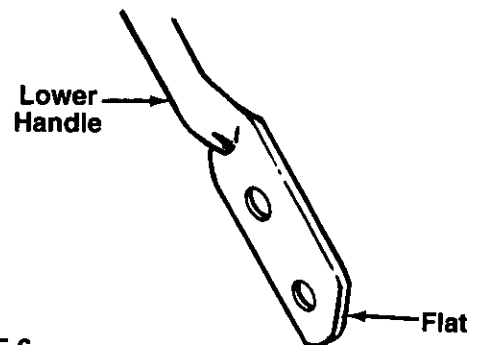

FIGURE 6.

### DRIVE CLUTCH CONTROL ADJUSTMENT

Use the adjustment wheel located in the clutch control housing to tighten the drive belt if mower does not self-propel with the drive clutch control engaged, or if drive belt is slipping (unit hesitates while engine maintains the same speed). See figure 7.

In addition, the adjustment wheel may also be used to determine the position in which the drive clutch control is engaged. If it is more comfortable to have the drive engaged with the lever further away from the handle, tighten the drive belt.

Make certain to retest the unit for neutral as instructed in the Operation Section. Move the adjustment wheel in the opposite direction to loosen the drive belt if necessary.

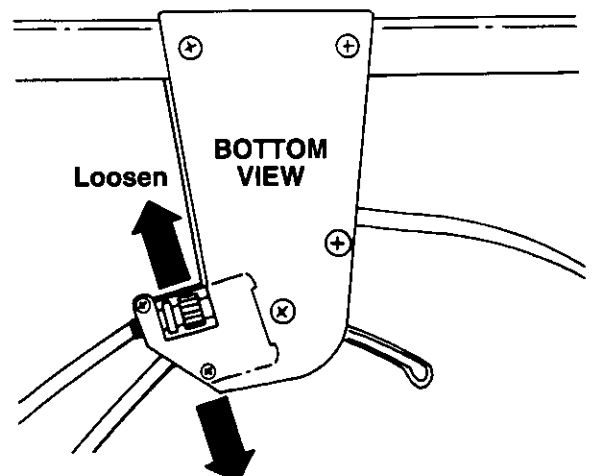

FIGURE 7. Tighten

## THROTTLE CONTROL ADJUSTMENT

If the throttle control requires adjustment or if it has been replaced, adjust the throttle control as follows.

1. Remove the screw shown in figure 8. Remove the cable clamp from the cable.
2. Push the throttle control lever on the handle all the way forward as far as it will go, then back it off one "click". Make certain the throttle control lever remains in this position.
3. Push the control lever on the engine as far toward the rear of the engine as it will go. Secure the cable in this position with the cable clamp and screw.

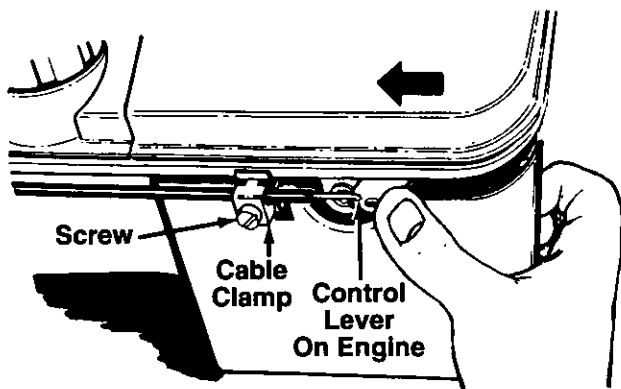

FIGURE 8.

## SIX SPEED SHIFT CABLE ADJUSTMENT

Periodic adjustment of the six speed shift cable may be required due to normal stretch and wear on the cable. Adjustment is needed if all six speeds cannot be obtained.

The adjustable cable bracket is located on the left side of the mower, beside the engine. To adjust, loosen the hex nut which secures the adjustable cable bracket. See figure 9. Place the shift lever in the sixth speed position. Make certain the belt is not pinched between the pulley halves. Pull backward on the adjustable cable bracket (toward the rear of the mower). Retighten the hex nut. Test the speeds on the mower (engine must be running).

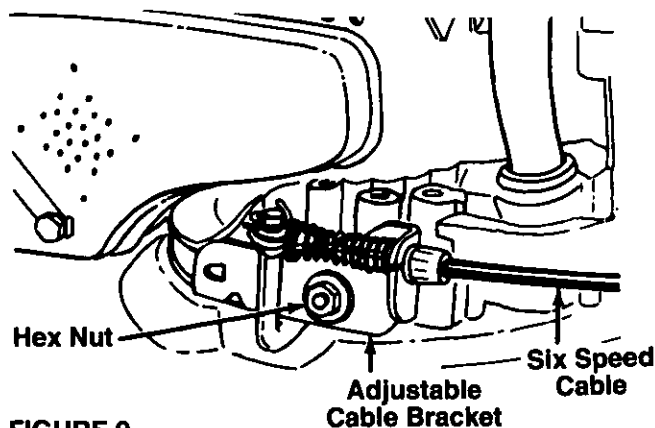

FIGURE 9.

## LUBRICATION



**WARNING:** Always stop engine and disconnect spark plug wire before cleaning, lubricating or doing any kind of work on lawn mower.

**Blade Control**—Lubricate the pivot points on the blade control handle and the brake cable at least once a season with light oil. See figure 10. The blade control must operate freely in both directions.

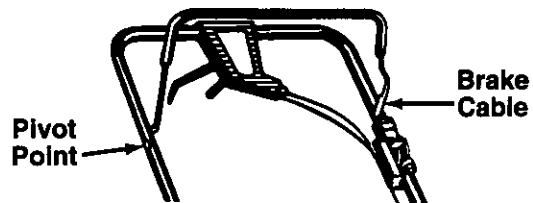

FIGURE 10.

**Wheels**—Lubricate the wheel bearings at least once a season with light oil. Also, if the wheels are removed for any reason, lubricate the surface of the axle bolt and the inner surface of the wheel with light oil. A 4 oz. plastic bottle of light oil lubricant is available. Order part number 737-0170. Engine oil may also be used.

**Engine**—Follow engine manual for lubrication instructions.

**Transmission**—The transmission is pre-lubricated and sealed at the factory. It does not require checking. If disassembled for any reason, fill with 2 ounces of Alvania grease, part number 737-0168.

## MAINTENANCE



**WARNING:** Be sure to disconnect and ground the spark plug wire before performing any repairs or maintenance.

**NOTE:** When tipping the unit, empty the fuel tank and keep engine spark plug or air cleaner side up.

## TROUBLE SHOOTING

Refer to page 10 of this manual for trouble shooting information.

## CUTTING BLADE

When removing the cutting blade for sharpening or replacement, protect hands by using heavy gloves or a rag to grasp the cutting blade. Remove the bolt and bell washer which hold the blade and adapter to the engine crankshaft. Remove the blade and adapter from the crankshaft.

If the blade or blade adapter needs replacing, remove the two small bolts, lock washers and nuts which hold the blade to the adapter.



**WARNING: Periodically inspect the blade adapter for cracks, especially if you strike a foreign object. Replace when necessary.**

When sharpening the blade, follow the original angle of grind as a guide. It is extremely important that each cutting edge receives an equal amount of grinding to prevent an unbalanced blade. An unbalanced blade will cause excessive vibration when rotating at high speeds, may cause damage to the mower and could break, causing personal injury.

It is recommended that the blade always be removed from the adapter for the best test of balance.

The blade can be tested by balancing it on a round shaft screwdriver. Remove metal from the heavy side until it balances evenly.

Before reassembling the blade and the blade adapter to the unit, lubricate the engine crankshaft and the inner surface of the blade adapter with light oil. Lubricating the bolt holes, bolts and inner surface of the nuts with light oil is also recommended. A 4 oz. plastic bottle of light oil lubricant is available. Order part number 737-0170. Engine oil may also be used.

When replacing the blade, be sure to install the blade with the side of the blade marked "Bottom" (or with part number) facing the ground when the mower is in the operating position.

#### Blade Mounting Torque

Center Bolt: 450 in. lbs. min., 600 in. lbs. max.

Blade Adapter Bolts: 200 in. lbs. min., 350 in. lbs. max.

To insure safe operation of your unit, all nuts and bolts must be checked periodically for correct tightness.

#### DECK

The underside of the mower deck should be cleaned after each use to prevent a buildup of grass clippings, leaves, dirt or other matter. If this debris is allowed to accumulate, it will invite rust and corrosion, and may prevent proper mulching.

The deck may be cleaned by tilting the mower and scraping clean with a suitable tool (make certain the spark plug wire is disconnected).

#### ENGINE

**Refer to the separate engine manual for all engine maintenance instructions.**

Maintain **engine oil** as instructed in the separate engine manual packed with your unit. Read and follow instructions carefully.

Service **air cleaner** every 25 hours under normal conditions. Clean every few hours under extremely dusty conditions. Poor engine performance and flooding

usually indicates that the air cleaner should be serviced. To service the air cleaner, refer to the separate engine manual packed with your unit.

The **spark plug** should be cleaned and the gap reset once a season. Spark plug replacement is recommended at the start of each mowing season; check engine manual for correct plug type and gap specifications.

**Clean the engine** regularly with a cloth or brush. Keep the cooling system (blower housing area) cleaned to permit proper air circulation which is essential to engine performance and life. Be certain to remove all grass, dirt and combustible debris from muffler area.

#### BELT REMOVAL AND REPLACEMENT

1. Place shift lever in third speed.
2. Disconnect the spark plug wire and ground it against the engine.
3. Drain the fuel tank or place a piece of plastic beneath the cap to prevent gasoline leakage.
4. Remove the transmission belt cover by removing three bolts. See figure 11.

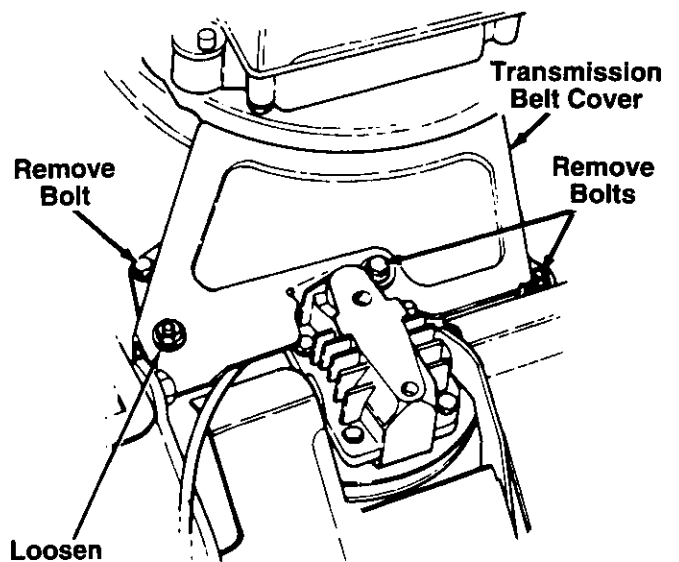

FIGURE 11.

5. Tip the mower on its side. Block securely.
6. Remove the center bolt which secures the blade to the crankshaft. See figure 12. Remove the blade and blade adapter.
7. Remove the two self-tapping screws which secure the lower pulley half. See figure 12.
8. Rotate the lower pulley half 90° clockwise (see figure 13) and remove from mower. Remove the belt from around the crankshaft.



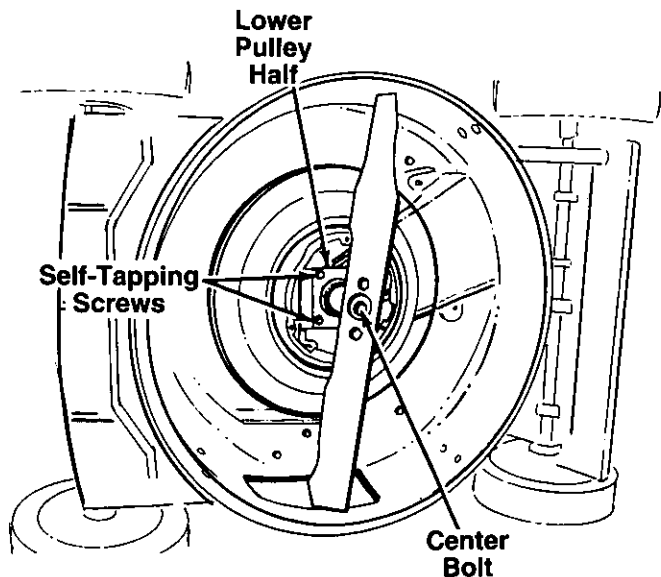

FIGURE 12.

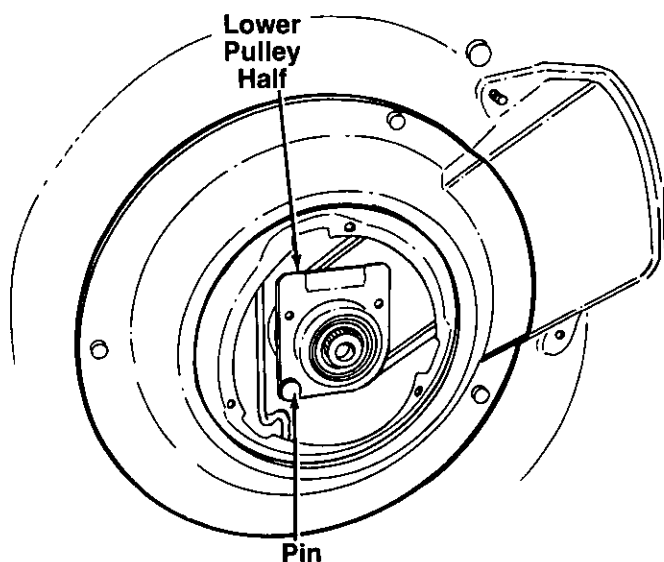

FIGURE 13.

9. Remove the belt from between the idler pulley and the belt guard on the idler pulley bracket. See figure 14.

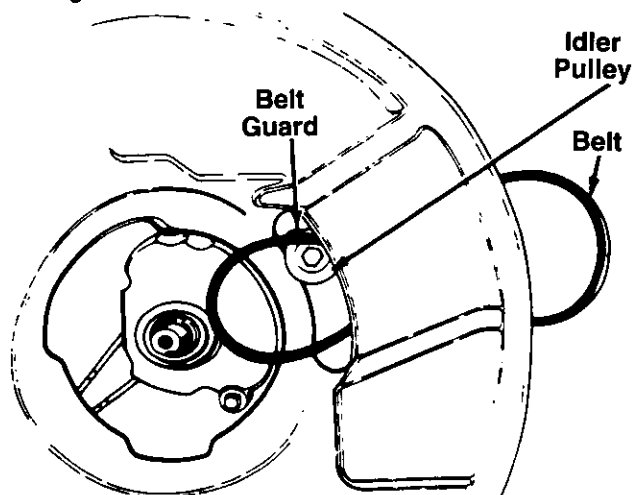

FIGURE 14.

10. Remove the belt from the transmission pulley.

11. Assemble the new belt as follows.

- A. Push the idler pulley up out of the way as shown in figure 14.
- B. Slide the belt in from the rear of the deck, and place it around the transmission pulley. See figure 14.
- C. Release the idler pulley so it falls down into position. Slide the belt in between the idler pulley and belt guard on the idler pulley bracket.
- D. Grease the crankshaft.
- E. Reassemble, following steps 1 through 8 in reverse order.

**NOTE:** When reassembling, make certain the pin on the lower pulley half is outside the belt. Also, be certain the belt guard on the transmission cover is approximately 1/8" away from the belt. Make certain to tighten all nuts and bolts securely. If plastic was placed under the gas cap, be certain to remove it.

## OFF-SEASON STORAGE

The following steps should be taken to prepare lawn mower for storage.

1. Clean and lubricate mower thoroughly as described in the lubrication instructions.
2. Refer to engine section for correct engine storage instructions.
3. Coat mower's cutting blade with chassis grease to prevent rusting.
4. Store mower in a dry, clean area. Do not store next to corrosive materials, such as fertilizer.

**NOTE:** When storing any type of power equipment in an unventilated or metal storage shed, care should be taken to rust-proof the equipment. Using a light oil or silicone, coat the equipment, especially cables and all moving parts.

# TROUBLE SHOOTING GUIDE

Trouble	Possible Cause(s)	Corrective Action
Engine fails to start	<ol style="list-style-type: none"> <li>1. Blade control handle disengaged.</li> <li>2. Spark plug wire disconnected.</li> <li>3. Throttle control lever not in correct starting position.</li> <li>4. Fuel tank empty, or stale fuel.</li> <li>5. Blocked fuel line.</li> <li>6. Faulty spark plug.</li> <li>7. Engine flooded.</li> </ol>	<ol style="list-style-type: none"> <li>1. Engage blade control handle.</li> <li>2. Connect wire to spark plug.</li> <li>3. Move throttle lever to FAST or START position.</li> <li>4. Fill tank with clean, fresh gasoline.</li> <li>5. Clean fuel line.</li> <li>6. Clean, adjust gap or replace.</li> <li>7. Remove spark plug, dry the plug, and crank engine with plug removed and throttle in off position. Replace spark plug, connect wire and resume starting procedures.</li> </ol>
Engine runs erratic	<ol style="list-style-type: none"> <li>1. Unit running in START position.</li> <li>2. Spark plug wire loose.</li> <li>3. Blocked fuel line or stale fuel.</li> <li>4. Vent in gas cap plugged.</li> <li>5. Water or dirt in fuel system.</li> <li>6. Dirty air cleaner.</li> <li>7. Carburetor out of adjustment.</li> </ol>	<ol style="list-style-type: none"> <li>1. Move throttle lever to FAST position.</li> <li>2. Connect and tighten spark plug wire.</li> <li>3. Clean fuel line; fill tank with clean, fresh gasoline.</li> <li>4. Clear vent.</li> <li>5. Drain fuel tank. Refill with fresh fuel.</li> <li>6. Clean air cleaner. †</li> <li>7. Adjust carburetor. †</li> </ol>
Engine overheats	<ol style="list-style-type: none"> <li>1. Engine oil level low.</li> <li>2. Air flow restricted.</li> <li>3. Carburetor not adjusted properly.</li> </ol>	<ol style="list-style-type: none"> <li>1. Fill crankcase with proper oil.</li> <li>2. Remove blower housing and clean. †</li> <li>3. Adjust carburetor. †</li> </ol>
Occasional skip (hesitates) at high speed	Spark plug gap too close.	Adjust gap to .030".
Idles poorly	<ol style="list-style-type: none"> <li>1. Spark plug fouled, faulty or gap too wide.</li> <li>2. Carburetor improperly adjusted.</li> <li>3. Dirty air cleaner.</li> </ol>	<ol style="list-style-type: none"> <li>1. Reset gap to .030" or replace spark plug.</li> <li>2. Adjust carburetor. †</li> <li>3. Clean air cleaner. †</li> </ol>
Excessive vibration	<ol style="list-style-type: none"> <li>1. Cutting blade loose or unbalanced.</li> <li>2. Bent cutting blade.</li> </ol>	<ol style="list-style-type: none"> <li>1. Tighten blade and adapter. Balance blade.</li> <li>2. Replace blade.</li> </ol>
Mower will not mulch grass	<ol style="list-style-type: none"> <li>1. Engine speed too low.</li> <li>2. Wet grass.</li> <li>3. Excessively high grass.</li> <li>4. Dull blade.</li> </ol>	<ol style="list-style-type: none"> <li>1. Set throttle between 3/4 and full throttle.</li> <li>2. Do not mow when grass is wet; wait until later to cut.</li> <li>3. Mow once at a high cutting height, then mow again at desired height or make a narrower cutting swath (1/2 width).</li> <li>4. Sharpen or replace blade.</li> </ol>
Uneven cut	<ol style="list-style-type: none"> <li>1. Wheels not positioned correctly.</li> <li>2. Dull blade.</li> </ol>	<ol style="list-style-type: none"> <li>1. Place all four wheels in same height position.</li> <li>2. Sharpen or replace blade.</li> </ol>

†Refer to separate engine manual packed with your mower.

**Note:** For repairs beyond the minor adjustments listed above, contact your nearest authorized service dealer.

**NOTE:** The use of any accessory on this walk-behind mower other than those manufactured by the mower manufacturer is not recommended. Grass catcher model number 190-106 is available as optional equipment.



**WARNING:** To reduce the risk of injury, do not operate mower unless rear trailing shield is in its proper place.

# Model 148

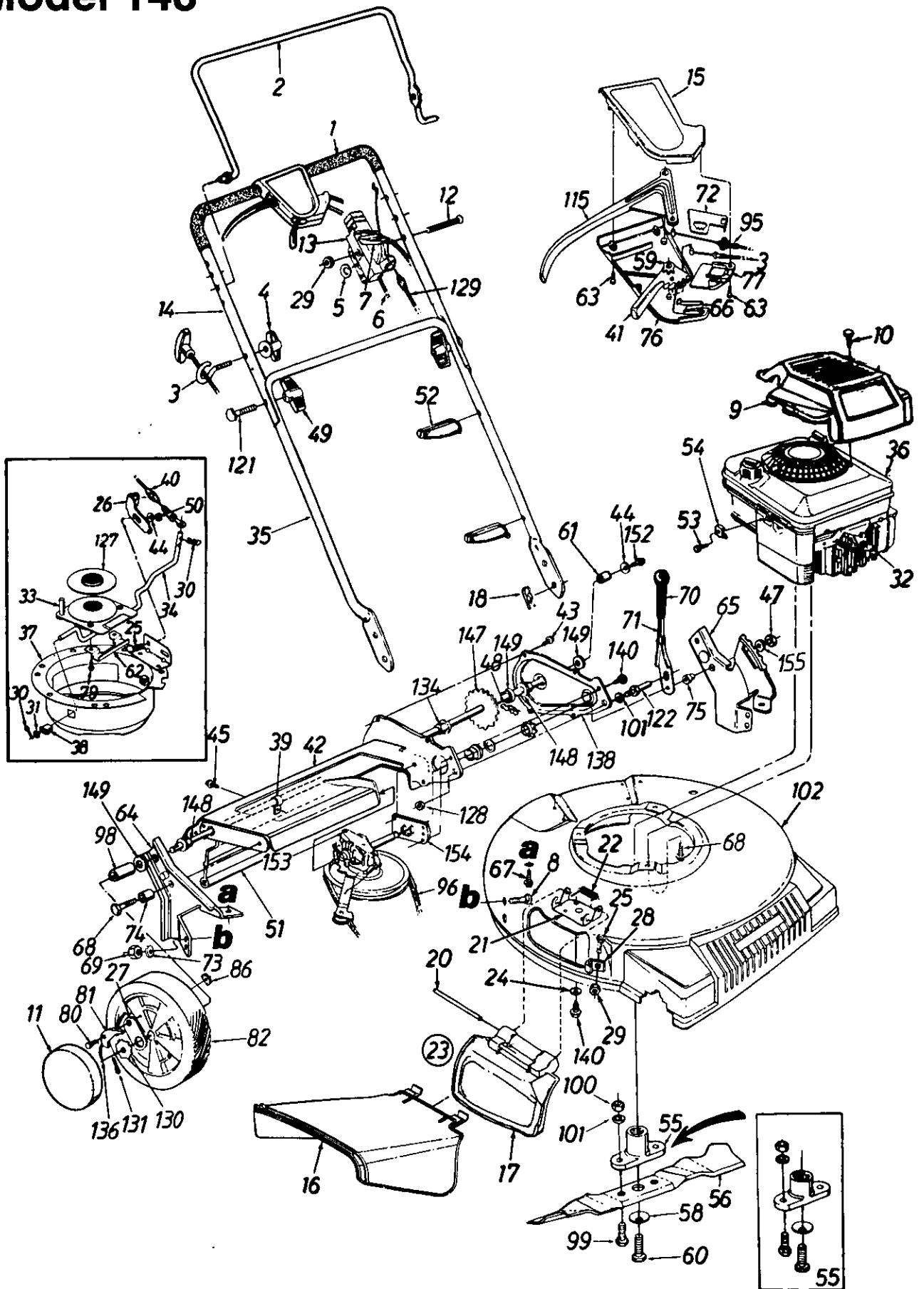

# Model 148

## PARTS LIST FOR MODEL 148 ROTARY MOWER

REF. NO.	PART NO.	DESCRIPTION	REF. NO.	PART NO.	DESCRIPTION
1	720-0226	Grip (2 Req'd.)	58	736-0453	Bell-Wash. .47" I.D. x 1.14" O.D.
2	647-0004	Control Handle	59	713-0397	Gear Insert
3	710-1205	Rope Guide	60	710-0561	Hex Bolt 7/16-20 x 2.5"
4	712-0397	Wing Nut 1/4-20 Thd.	61	748-0190	Spacer .513" I.D.
5	736-0501	Curved Spring Wash. .66" I.D.	62	782-7563	Bracket—Shift Plate
6	746-0843	Throttle Wire—55" Lg.	63	710-0841	C-Sunk Tap Scr. #10 x .75" Lg.
7	746-0876	Throttle Lever	64	682-3006A	R.H. Handle Wheel Brkt. Ass'y.
8	710-0260	Carriage Bolt 5/16-18 x .62" Lg.	65	682-3007A	L.H. Handle Wheel Brkt. Ass'y.
9	751B281191	Engine Shroud	66	732-0627	Shift Lever Spring
10	710-1256	Hi-Lo Screw #10 x 1.25" Lg.	67	710-0603	Hex B-Tap Scr. 5/16-18
11	731-0982A	Hub Cap	68	710-0654A	Hex TT-Tap Scr. 3/8-16
12	710-0605	Oval C-Sunk Mach. Scr.	69	712-0267	Hex Nut 5/16-18 Thd.*
13	746-0875	Throttle Body	70	720-0223	Grip
14	749-0539B	Upper Handle	71	732-0725	Height Adj. Lever
15	731-0904	Upper Control Housing	72	16864	6 Spd. Rack Cable Brkt.
16	731-1407	Side Chute Deflector	73	736-0242	Bell-Wash. 5/16" I.D.
17	731-1404	Mulch Plug	74	750-0736	Spacer .383" I.D.
18	714-0104	Internal Cotter Pin 5/16" Dia.	75	750-0624	Shld. Spacer .5" Dia.
20	747-0710	Hinge Pin	76	731-0905	Lower Control Housing
21	782-7006	Plug Adapter	77	731-0906	Cable Mounting Cap
22	732-0593	Torsion Spring	79	710-0653	Hex Wash. Hd. Tap Scr. 1/4-20 x .38" Lg.
23	682-7000	Mulch Plug Ass'y. Comp. (Incl. Ref. 17, 20, 21, 22)	80	738-0137	Shld. Scr. .342" Dia. x .268
24	736-0270	Bell-Wash. .265" I.D. x .75" O.D.	81	748-0188B	Pawl
25	710-0167	Carriage Bolt 1/4-20 x .5" Lg.	82	734-1514B	Wheel Ass'y. Comp.
26	17070	Adjustable Cable Bracket		741-0486B	Wheel Bearing
27	16855	Pawl Plate	86	712-0414	Weld Top L-Nut 1/4-20 Thd.
28	782-7009	Chute Stop Bracket	95	746-0710A	S.P. Cable
29	712-0324	Hex L-Nut 1/4-20 Thd.	96	754-0343	"V"-Belt
30	714-0507	Cotter Pin 3/32" Dia. x .75"	98	711-0313	Sleeve .526" I.D.
31	736-0278	FI-Wash. .328" I.D. x .68"	99	710-1055	Hex Bolt 3/8-24 x 1.0" Lg.
32	735-0639	Spark Plug Insulator	100	712-0241	Hex Nut 3/8-24 Thd.
33	682-7511	Lower Pulley Half Ass'y.	101	736-0169	L-Wash. 3/8" I.D.
34	747-0882	Shift Rod	102	782-0023	21" Deck Ass'y.
35	749-0928	Lower Handle	115	731-0620	Control Lever
36	—	Engine—5 H.P.	121	710-1174	Curved Hd. Bolt 5/16-18 x 2" Lg.
37	682-7514	Housing Ass'y.	122	711-0805	Shld. Pin 1.43" Lg.
38	731-1137	Flanged Bushing	127	756-0503	Pulley Half—Serrated
39	726-0287	Clamp	128	712-0711	Hex Jam Nut 3/8-24 Thd.*
40	746-0706	6 Spd. Cable	129	746-0550	Control Cable—39"
41	731-0924	6 Spd. Shift Lever	130	748-0318	Ratchet Wheel 1.62" O.D.
42	682-7513	Chain—Axle Ass'y.	131	714-0115	Cotter Pin 1/8" Dia. x 1"
43	710-0352	Hex B-Tap Scr. 1/4" x .38"	134	741-0522	Hex Flange Bearing
44	736-0270	Bell-Wash. 1/4" I.D.	136	10622B	Spring—Nylon
45	710-0351	Truss Mach. B-Tap Scr. #10 x .5"	138	682-7506	Chain Cover Ass'y.
47	712-0296	Hex Patch L-Nut 3/8-24 Thd.	140	710-0599	Hex TT-Tap Scr. 1/4-20 x .50"
48	713-0361	#48 Chain .500" Pitch x 38 Links	147	738-0864	Rear Shaft Ass'y. 21.44" Lg.
49	720-0241	Hand Knob	148	741-0324	Hex Flange Brg. .506" I.D.
50	712-0291	Hex L-Nut 1/4-20 Thd.	149	736-0160	FI-Wash. .531" I.D. x .930"
51	731-1421	Rear Flap 3.75" x 17.5" Lg.	152	710-0751	Hex Bolt 1/4-20 x .62" Lg. (Grade 5)
52	726-0240	Cable Tie	153	717-0417B	Transmission Comp. (See Breakdown)
53	710-1237	Hex Wash. Hd. Scr. #10-32 x .62" Lg.	154	16500A	Hex Bearing Cup
54	751-0568	Casing Clamp	155	736-0300	FI-Wash. .385" I.D. x .87" O.D.
55	753-0519	Blade Adapter Kit			
56	742-0721	21" Mulching Blade			

**NOTE:** Specifications subject to change without notice or obligation.

\*For faster service obtain standard nuts, bolts and washers locally. If these items cannot be obtained locally, order by part number and size as shown on parts list.

# Model 148

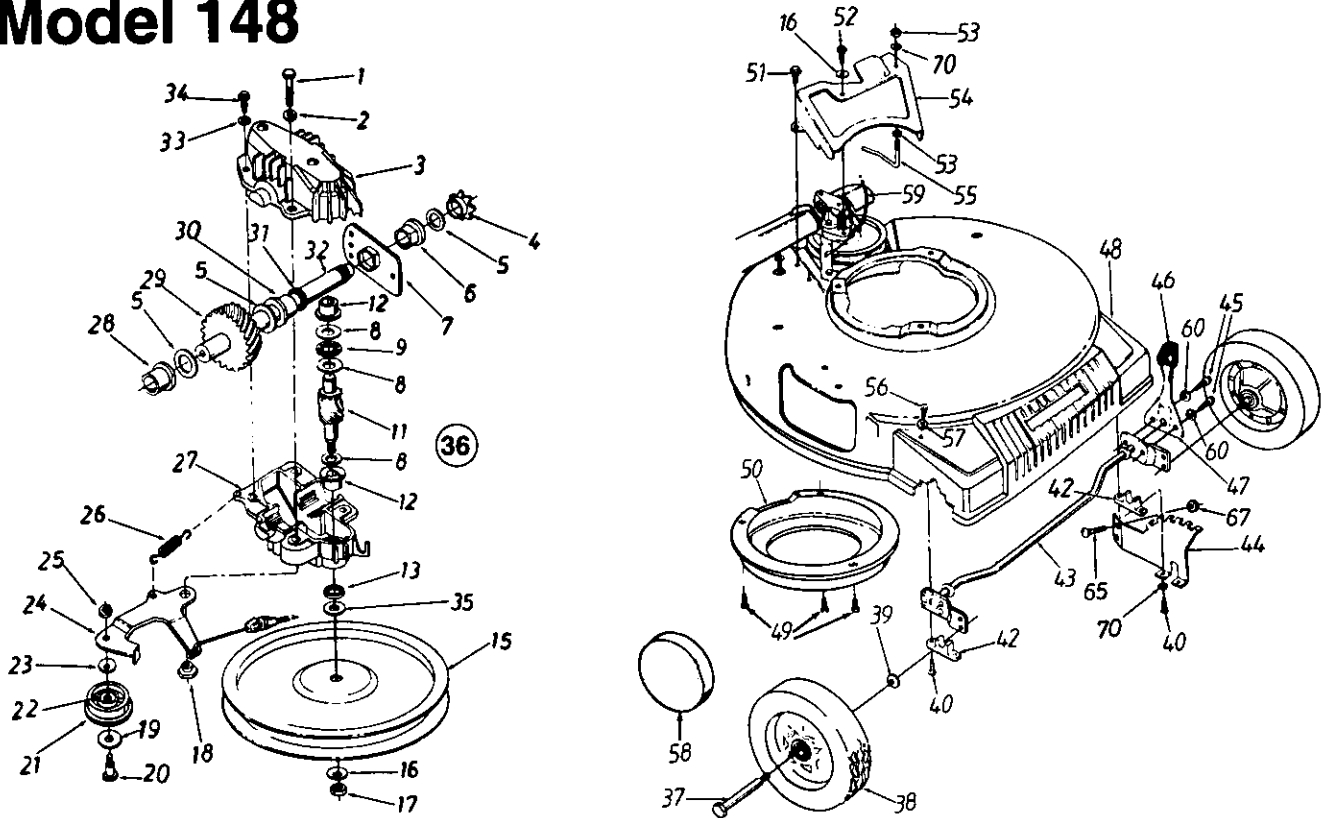

**PARTS LIST FOR MODEL 148 ROTARY MOWER**

REF. NO.	PART NO.	DESCRIPTION	REF. NO.	PART NO.	DESCRIPTION
1	710-1062	Hex Patch Bolt 1/4-20 x 1.25"†	34	710-0436	Hex B-Tap Scr. #10 x .62"†
2	736-0329	L-Wash. 1/4" I.D.*	35	736-0410	Hex Washer .26" x .88"
3	717-0418A	Upper Hsg. Half†	36	717-0417B	Transmission Comp.
4	713-0400	#48 Sprocket 7 T x 1/2 Pitch†	37	738-0102	Front Axle Bolt
5	736-0336	FI-Wash. 5/8" I.D. x .030†	38	734-1517B	Wheel Ass'y. Comp.
6	741-0413	Hex Flange Brg. .631" I.D.†		741-0484	Wheel Bearing
7	16500A	Hex Bearing Cup†		736-0504	Wave Washer
8	736-0314	Thrust Wash. .382" I.D. x .70" O.D.†	39	736-0105	Bell-Wash. .380" I.D. x .88
9	741-0479	Thrust Bearing .375" I.D. x .812" O.D.†	40	710-1241	Hex Wash. Hd. Scr. 1/4 x 1" Lg.
11	717-1216	11 Tooth Pinion Shaft†	42	741-0492A	Block Bushing
12	748-0208A	Flange Bearing†	43	17733	Axle Ass'y.
13	721-0212	Oil Seal†	44	782-0516	Height Adj. Bracket
15	756-0330A	FI-Pulley 5.06" O.D.	45	710-0653	Hex TT-Tap Scr. 1/4-20 x .38"
16	736-0270	Bell-Wash. .265" I.D. x .75"	46	720-0190	Knob
17	712-0351	Hex L-Nut 1/4-28 L.H. Thd.	47	732-0639	Spring Lever
18	738-0440	Shld. Spacer .375" Dia. x .170	48	731-1281	Plastic Front End
19	736-0344	FI-Wash. .390" I.D. x 1.0"	49	710-0352	Hex B-Tap Scr. 1/4" x .38"
20	738-0826	Shld. Bolt .375" Dia. x .40"	50	782-7558	Belt Cover
21	756-0558	FI-Idler Plastic 1.50" Dia.	51	710-0599	Hex Wash. Hd. TT-Scr. 1/4-20
22	741-0556	Needle Brg. .375" x .31	52	710-0896	Hex Wash. Hd. B-Tap Scr. 1/4 x .62" (Spec.)
24	17052A	Idler Brk't. Ass'y.	53	712-0287	Hex Nut 1/4-20 Thd.*
25	712-0138	Hex Patch L-Nut 1/4-28 Thd.	54	17058A	Transmission Belt Cover
26	732-0357	Extension Spring 1.12" Lg.	55	747-0549	S.P. Belt Guard
27	717-0419A	Lower Hsg. Half†	56	710-1242	Torx Truss Hd. Scr. 5/16 x .75"
28	741-0415	Flange Bearing .566 Dia.†	57	736-0242	Bell-Wash. .345" I.D. x .88"
29	717-0422A	33 Tooth Helical Gear†	58	731-0982A	Hub Cap
30	741-0414	Flange Bearing .629 Dia.†	59	746-0710A	S.P. Cable
31	721-0213	Oil Seal .625 Dia.†	60	736-0222	External L-Wash. 1/4" I.D.
32	738-0607A	Gear Sprocket Shaft†	65	710-0167	Carr. Bolt 1/4-20 x .5" Lg.
33	736-0722	L-Wash. #10 I.D.†	67	712-3027	Hex Flange L-Nut 1/4-20 Thd.
			70	736-0329	L-Wash. 1/4" I.D.*

†Part of Transmission Complete, Ref. No. 36.

USE THIS SHEET AS A GUIDE TO DETERMINE SLOPES WHERE YOU MAY NOT OPERATE SAFELY.

# SLOPE GAUGE

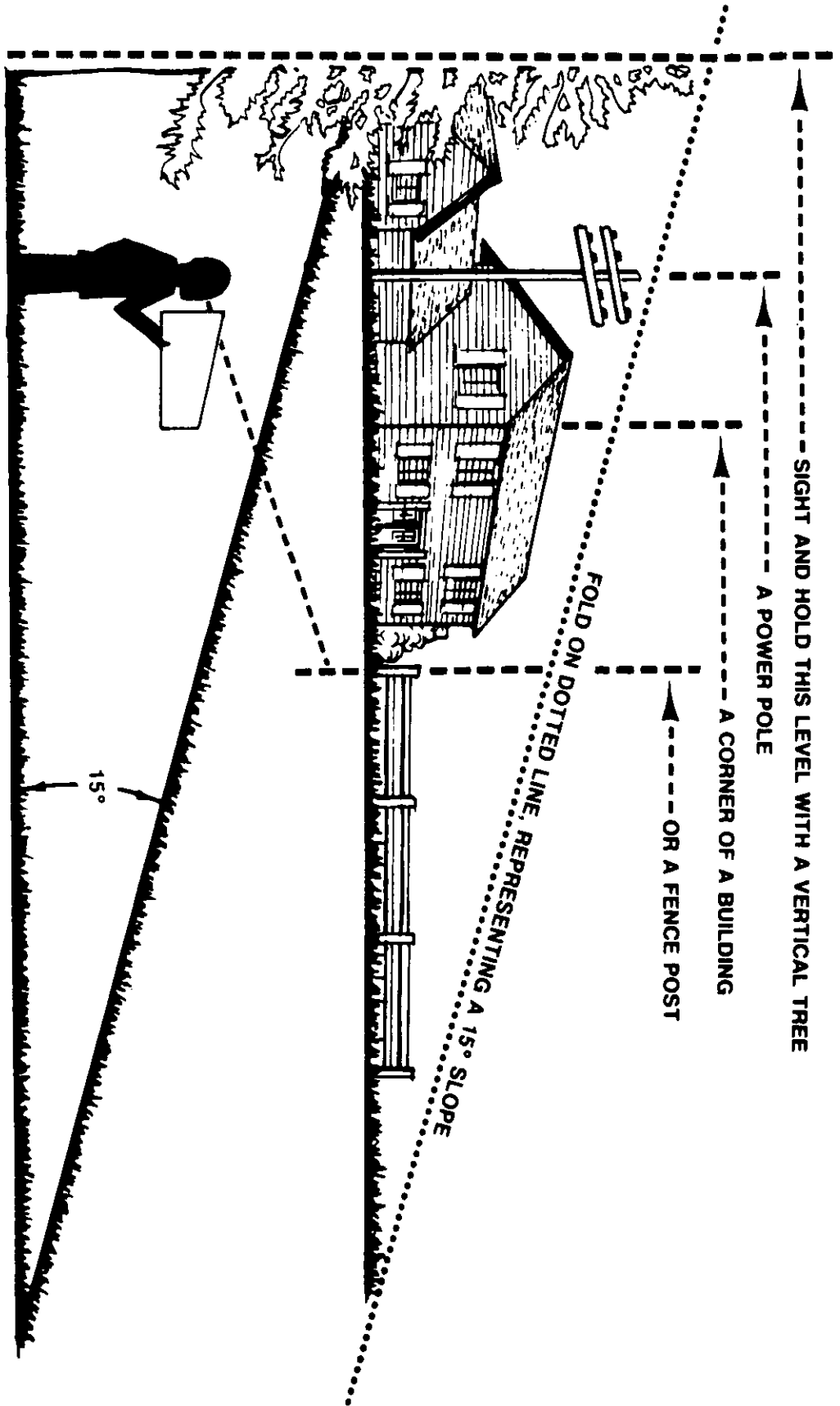

Do not mow on inclines with a slope in excess of 15 degrees (a rise of approximately 2-1/2 feet every 10 feet). A riding mower could overturn and cause serious injury. If operating a walk-behind mower on such a slope, it is extremely difficult to maintain your footing and you could slip, resulting in serious injury.

Operate RIDING mowers up and down slopes, never across the face of slopes.

Operate WALK-BEHIND mowers across the face of slopes, never up and down slopes.

**Cub Cadet.**

**Power Equipment**

**LIMITED WARRANTY**  
**TWO-YEAR RESIDENTIAL**  
**ONE-YEAR COMMERCIAL**

Proper maintenance of your Cub Cadet equipment is the owner's responsibility. Follow the instructions in your owner's manual for correct lubricants and maintenance schedule. Your Cub Cadet dealer carries a complete line of quality lubricants and filters for your equipment's engine, transmission, chassis and attachments.

**RIDING MOWERS, LAWN TRACTORS, GARDEN TRACTORS, CUB CADET ATTACHMENTS  
AND HOME MAINTENANCE PRODUCTS**

This limited warranty for residential users, covers any defect in materials or workmanship in your Cub Cadet equipment for two years from the date of purchase for the first user purchaser.

We will replace or repair any part or parts without charge through your authorized Cub Cadet dealer.

Batteries have a one-year prorated limited warranty with 100% replacement during the first three months.

V-belts for either the traction drive or any attachments are covered for one year only.

Cub Cadet equipment used commercially is warranted for one year only.

(Commercial use is defined as either having hired operators or used for income producing purpose.)

**ITEMS NOT COVERED**

The warranty does not cover routine maintenance items such as lubricants, filters (oil, fuel, air and hydraulic), cleaning, tune-ups, brake and/or clutch inspection, adjustments made as part of normal maintenance, blade sharpening, set-up, abuse, accidents and normal wear. It does not cover incidental costs such as transporting your equipment to and from the dealer, telephone charges or renting a product temporarily to replace a warranted product.

There is no other express warranty.

**HOW TO OBTAIN SERVICE**

Contact your authorized Cub Cadet servicing dealer who sold you your Cub Cadet equipment. If this dealer is not available, see the Consumer Yellow Pages under "lawn mowers" for the name of a dealer near you.

If you need further assistance in finding an authorized Cub Cadet servicing dealer, contact:

Cub Cadet Corporation  
Post Office Box 368023  
Cleveland, Ohio 44136-9723

**HOW DOES STATE LAW APPLY?**

This limited warranty gives you specific legal rights, and you may also have other rights which vary from state to state.