

# Owner's Manual

---

## LAWN TRACTORS

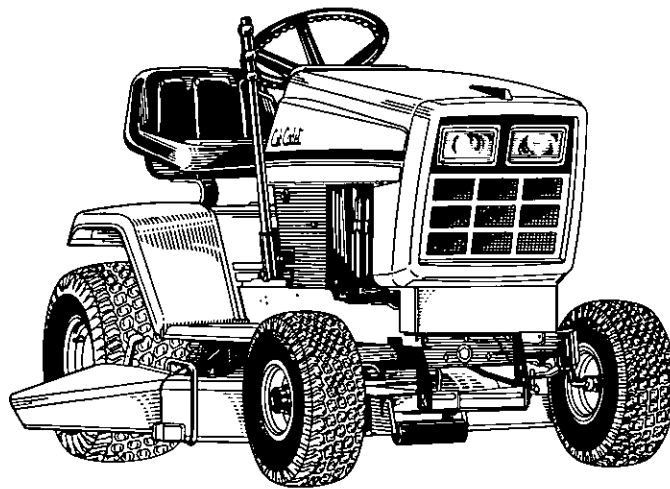

### Model Numbers

1415

1420

### Important:

**Read Safety Rules and Instructions Carefully**

Thank you for purchasing an American-built product.

**CUB CADET CORPORATION • P.O. BOX 36930 • CLEVELAND, OHIO 44136**

PRINTED IN U.S.A.

FORM NO. 772-3932

## Cub Cadet Corporation's Promise To You

We promise you, the first user purchaser, that we will replace or repair any part or parts of your new outdoor power product which is defective in material or workmanship without charge for either parts or labor during the first year following delivery to you.

We also promise you, the first user purchaser, a second year warranty on the engine and drive train of your new *Cub Cadet* Tractor, Lawn Tractor or Riding Tractor.

### What the second year covers

(A) It will cover the engine internal parts contained within the engine shielding except for points, condensers, spark plugs, air filters, oil filters, and routine maintenance parts.

(B) It will cover the tractor drive train including drive shafts, drive shaft clutch, all parts enclosed by transmission housing, and axle housing, axle shafts, final drives, spindle pulleys, spindle bearings, and electric PTO clutch.

**Home Maintenance Products:** We promise you, the first user purchaser, a 1 year warranty on all Home Maintenance Products. This will cover Push Mowers, Self Propelled Mowers, Utility Trailers, Walk Behind Tillers, Chore Performers and Snow Throwers.

The Tecumseh engine, used on Walk Behind Snow Throwers, will carry a 2 year warranty on the engine only.



### Cub Cadet Attachments:

We promise you, the first user purchaser, that we will replace or repair any part or parts which are defective in material or workmanship without charge for parts or labor during the first year following delivery to you. This will cover all *Cub Cadet* attachments. This does not include Approved Allied Equipment which is sold and warranted directly by the manufacturer.

### Obtaining Warranty Service Through Cub Cadet Dealers

Warranty repairs will be made by your selling *Cub Cadet* dealer or any *Cub Cadet* dealer authorized to sell the type of equipment involved during the normal working hours of the dealer service department. You, the purchaser, are responsible for transportation of the equipment to the dealership for warranty service or for any service call expense, along with any overtime labor you request.

### Replacement Parts Warranty

*Cub Cadet* parts which are furnished and installed under this warranty are themselves within the coverage of this warranty for the duration of the original warranty period or for ninety days after installation, whichever period shall expire last.

### What is not Covered

Tires and tubes are not covered by this warranty, but are warranted by their manufacturer. Regular maintenance replacement items such as spark plugs, ignition points, condensers, belts, cutting parts, filters and lubricants, and maintenance adjustments such as fuel system cleaning, engine tune-up, brake and/or clutch inspection or adjustment, when such replacement or adjustments are made as part of normal maintenance service are excluded from coverage. Any non-*Cub Cadet* product which you may have installed in or upon the product is also excluded.

No person is authorized to give any other warranty or to assume any other liabilities on the Company's behalf unless made or assumed in writing by the Company, and no person is authorized to give any warranties or to assume any liabilities on the seller's behalf unless made or assumed in writing by the seller.

### Limitations On Our Responsibility

Please carefully note that this is a two-way agreement. We promise to make free repairs or replacements as stated, but you agree, that except for our obligation to make good on this promise, we shall not be responsible for any expenses or inconvenience which you might incur or experience with respect to our product, nor shall we be liable for defects, damage, or failures caused by unauthorized alterations, unreasonable use, accident or abuse, including failure to provide reasonable and necessary maintenance, after our product has been delivered to you. Some states do not allow the exclusion or limitation of incidental or consequential damages, so the above limitation or exclusion may not apply to you. This warranty gives you specific legal rights, and you may also have other rights which vary from state to state.

### Personal Use

The foregoing paragraphs constitute *Cub Cadet* Corporation's entire warranty with respect to any product purchased and used for personal, family, or household purposes as distinguished from commercial usage.

### Commercial Use:

All *Cub Cadet* products will be warranted against defective parts or workmanship. This is for *Cub Cadet* Tractor, Attachments and Home Maintenance products and for one year only.

THIS WARRANTY IS IN LIEU OF ALL OTHER WARRANTIES, EXPRESSED OR IMPLIED. WARRANTIES OF MERCHANTABILITY AND FITNESS FOR PARTICULAR PURPOSE ARE EXCLUDED, AS ARE ALL OTHER REPRESENTATION TO THE USER-PURCHASER, AND ALL OTHER OBLIGATIONS OR LIABILITIES, INCLUDING LIABILITY FOR INCIDENTAL AND CONSEQUENTIAL DAMAGES, ON THE PART OF THE COMPANY OR THE SELLER.

# CONTENTS

Warranty .....	2	Optional Equipment and Accessories .....	25
Safe Operations .....	3	Mowing .....	26
To The Owner .....	7	Maintenance Chart .....	27
Serial No. Location .....	7	Trouble Shooting .....	28
Controls .....	8	Lubrication Table .....	30
Operation .....	11	Lubrication Guide .....	30
Adjustments .....	15	Specifications .....	33
Maintenance .....	20	Slope Gauge .....	35
Off-Season Storage .....	25		



Instructions given with this symbol are for personal safety. Be sure to follow them.



## WARNING

This unit is equipped with an internal combustion engine and should not be used on or near any unimproved forest-covered, brush-covered or grass-covered land unless the engine's exhaust system is equipped with a spark arrester meeting applicable local or state laws (if any). If a spark arrester is used, it should be maintained in effective working order by the operator.

In the State of California the above is required by law (Section 4442 of the California Public Resources Code). Other states may have similar laws. Federal laws apply on federal lands. A spark arrester muffler is available at your nearest engine authorized service center.



## WARNING

To reduce the potential for any injury, comply with the following safety instructions. Failure to comply with the instructions may result in personal injury.

## SAFE OPERATION PRACTICES FOR RIDING VEHICLES

1. Read the owner's manual carefully in its entirety before attempting to assemble or operate this unit. Keep this manual in a safe place for future and regular reference and for ordering replacement parts.
2. This unit is a precision piece of power equipment not a plaything. Therefore, exercise extreme caution at all times.
3. Know the controls and how to stop quickly - READ THE OWNER'S MANUAL.
4. Do not allow children to operate vehicle. Do not allow adults to operate it without proper instruction. Only persons well acquainted with these rules of safe operation should be allowed to use your mower.
5. No one should operate this unit while intoxicated or while taking medication which impairs the senses or reactions.
6. Wear sturdy, rough-soled work shoes and close-fitting slacks and shirts to avoid entanglement in the moving parts. Never operate a unit in bare feet, sandals, or sneakers.
7. To prevent injury, do not carry passengers or give rides. Keep children, pets and bystanders out of the area while mowing. Only the operator should ride on the unit and he/she should ride only in the seat.
8. Check overhead clearance carefully before driving under power lines, guy wires, bridges or low hanging tree branches; before entering or leaving

buildings, or in any other situation where the operator may be struck or pulled from the unit. Such negligence could result in serious injury.

9. To maintain control of the unit and reduce the possibility of upset or collision, operate the tractor smoothly. Avoid erratic operation and excessive speed.
10. Keep the area of operation clear of all persons, particularly small children and pets. Stop engine when they are in the vicinity of your mower. Although the area of operation should be completely cleared of foreign objects, a small object may have been overlooked and could be accidentally thrown by the mower in any direction and cause injury.
11. Clear work area of objects which might be picked up and thrown in any direction by the mower and cause injury.
12. Stop the blade(s) when crossing gravel drives, walks or roads.
13. Disengage all attachment clutches and shift into neutral before attempting to start engine.
14. Disengage power to attachment(s) and stop engine before leaving operating position.
15. Do not put hands or feet near or under rotating parts. Stay clear of the discharge opening at all times as the rotating blade(s) can cause injury.
16. Disengage power to attachment(s) and stop engine before making any repairs or adjustments. Disconnect the spark plug wire(s) and keep the wire(s) away from the plug to prevent accidental starting.
17. Before attempting to unclog the mower or discharge chute, stop the engine. The mower blade(s) may continue to rotate for a few seconds after the engine is shut off. Therefore, be sure the blade(s) have stopped completely. Disconnect the spark plug wire(s) and keep the wire(s) away from the plug to prevent accidental starting.
18. Disengage power to attachment(s) when transporting or not in use.
19. Take all possible precautions when leaving vehicle unattended such as disengaging power-take-off, lowering attachments, shifting into neutral, setting parking brake, stopping engine and removing key.
20. Do not stop or start suddenly when going uphill or downhill. Mow up and down face of steep slopes; never across the face. Use extreme caution if it is necessary to drive the tractor up an incline or back the tractor down an incline because the front of the tractor could lift and rapidly flip over backward which could cause serious injury.
21. Reduce speed on slopes and in sharp turns to prevent tipping or loss of control. Always keep the tractor in gear when going down steep hills to take advantage of engine braking action.
22. Stay alert for holes in terrain and other hidden hazards.
23. Use care when pulling loads or using heavy equipment.
  - A. Use only approved drawbar hitch points.
  - B. Limit loads to those you can safely control.
  - C. Do not turn sharply. Use care when backing.
  - D. Use counterweight(s) or wheel weights when suggested in owner's manual.
24. Watch out for traffic when crossing or near roadways.
25. When using any attachments, never direct discharge of material toward bystanders. Do not allow anyone near vehicle while in operation.
26. Handle fuel with care. It is highly flammable.
  - A. Use approved fuel container.
  - B. Never remove cap or add fuel to a running or hot engine or fill fuel tank indoors. Wipe up spilled fuel.
  - C. Open doors if engine is run in garage. Exhaust fumes are dangerous. Do not run engine indoors.
27. Keep the vehicle and attachments in good operating condition, and keep safety devices in place. Use guards as instructed in operator's manual.
28. Keep all nuts, bolts, and screws tight to be sure the equipment is in safe working condition.
29. Never store the equipment with fuel in the tank inside a building where fumes may reach an open flame or spark. Allow engine to cool before storing in any enclosure.
30. To reduce fire hazard, keep engine free of grass, leaves or excessive grease.
31. The vehicle and attachment should be stopped and inspected for damage after striking a foreign object. The damage should be repaired before restarting and operating the equipment.
32. Do not change the engine governor settings or overspeed the engine.

33. When using the vehicle with mower, proceed as follows:
  - A. Mow only in daylight or in good artificial light.
  - B. Never make a cutting height adjustment while engine is running if operator must dismount to do so.
  - C. Shut the engine off and wait until the blade comes to a complete stop before removing the grass catcher.
  - D. Check blade mounting bolts for proper tightness at frequent intervals.
34. Check grass catcher bags frequently for wear or deterioration. For safety protection, replace only with new bag meeting original equipment specifications.
35. Look behind to make sure the area is clear before placing the transmission in reverse and continue looking behind while backing up. Disengage blades before shifting into reverse and backing up.
36. This unit should not be driven up a ramp onto a trailer or truck under power, because the unit could tip over, causing serious personal injury. The unit must be pushed manually to load properly.

**PRODUCT GRAPHICS**

Keep safety product graphics (decals) clean. Replace any safety graphic that is damaged, destroyed,

missing, painted over or can no longer be read. Replacement safety graphics are available through your dealer.

 **CAUTION**

**LOOK!  
BEFORE  
BACKING**

**RECEIVE INSTRUCTION** – Read operator's manual. Learn to operate this machine **SAFELY**. Don't risk **INJURY** or **DEATH**.

1. Before starting engine or operation. Be familiar with controls. Be in operator's position with transmission in neutral, PTO turned off, and brake depressed.
2. Keep shields in place. Keep away from moving parts.
3. **NO RIDERS!** Keep all people and pets a safe distance away.
4. Don't point mower discharge at people.
5. Avoid slopes. Tractors can be rolled over.
6. Before leaving operator's position:  
Shut off PTO. Place transmission in neutral. Set brake lock. Shut off engine. Remove ignition key. Wait for all movement to stop before servicing or cleaning.
7. Do not fill gasoline tank when engine is running or while engine is hot. Tighten cap securely.

33 12 (11-251, 271)

**GENERAL SAFETY INSTRUCTIONS CAUTION LOCATED ON THE FRAME COVER.**

 **CAUTION**

Electrical system is 12 volt negative ground. When using booster with jumper cables, precautions must be taken to prevent personal injury or damage to electrical parts.

1. Attach one end of jumper cable to positive terminal of booster battery and other end to positive terminal of vehicle battery.
2. Attach one end of second cable to negative terminal of booster battery and other end to vehicle frame away from battery.
3. To remove cables, reverse above sequence exactly to avoid sparks. See operator's manual for additional information.

**CAUTION—BOOSTER BATTERY INSTRUCTIONS LOCATED UNDER THE HOOD.**

# TO THE OWNER

Assembled in this manual are operation, lubrication, and maintenance instructions for the *Cub Cadet* 1415 and 1420 Tractors. The material has been prepared in detail to help you better understand the correct care and efficient operation of your tractor. Before you operate the tractor, study this manual carefully. Additional copies may be ordered from your dealer at a nominal price.

Your local authorized dealer is interested in the performance you receive from your tractor. He has factory-trained servicemen, informed in the latest method of servicing tractors, modern tools, and original-equipment service parts which assure proper fit and good performance.

The *Cub Cadet* 1420 Tractor has a hydrostatic drive unit and will require minimum service if recommended operation and maintenance procedures are followed.

To obtain top performance and assure economical operation the tractor should be inspected, depending on its use, periodically, or at least once a year, by your authorized dealer.

When in need of parts, always specify the model, chassis, and engine serial numbers, including the prefix and suffix letters. Write these serial numbers in the space provided on this page.

Should you have difficulties with the unit, consult your authorized dealer. **UNDER NO CIRCUMSTANCES SHOULD YOU ATTEMPT TO SERVICE THESE UNITS YOURSELF.** Only your dealer is authorized to repair or replace units on this drive under the terms of the warranty. Should you desire additional information not found in this manual, contact your authorized *Cub Cadet* dealer.

## SERIAL NUMBER LOCATION



LEFT and RIGHT indicate the left and right sides of the tractor when facing forward in the driver's seat. Reference to FRONT indicates grille end of the tractor; to REAR the drawbar end.

Chassis serial number plate is on the left hand side of pedestal. (Refer to Figure 1.)

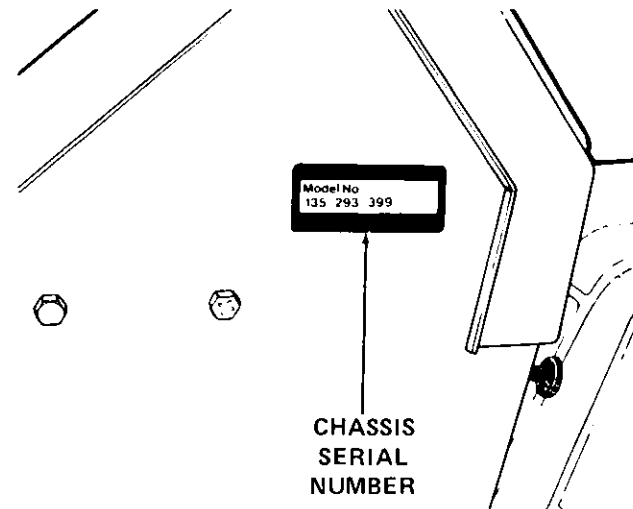

Figure 1

Engine serial number plate is located on the engine shroud. (Refer to Figure 2.)

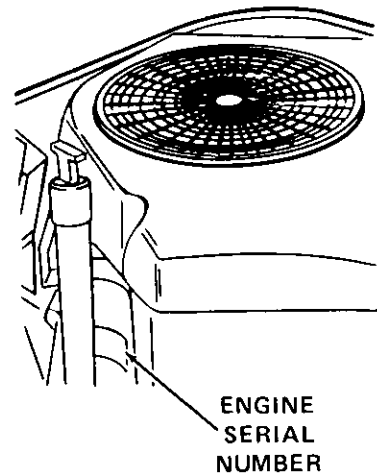

Figure 2

MODEL \_\_\_\_\_

DELIVERY DATE \_\_\_\_\_

# CONTROLS

Your *Cub Cadet* Tractor has been safety engineered. Thoroughly acquaint yourself with all the instruments and controls before attempting to start or operate the tractor.

## A. CHARGE INDICATOR

This instrument indicates whether the alternator is charging or the battery is discharging. If it shows discharge continuously, investigate the cause to avoid completely discharging the battery and possible damage to the charging circuit. (Refer to Figure 3.)

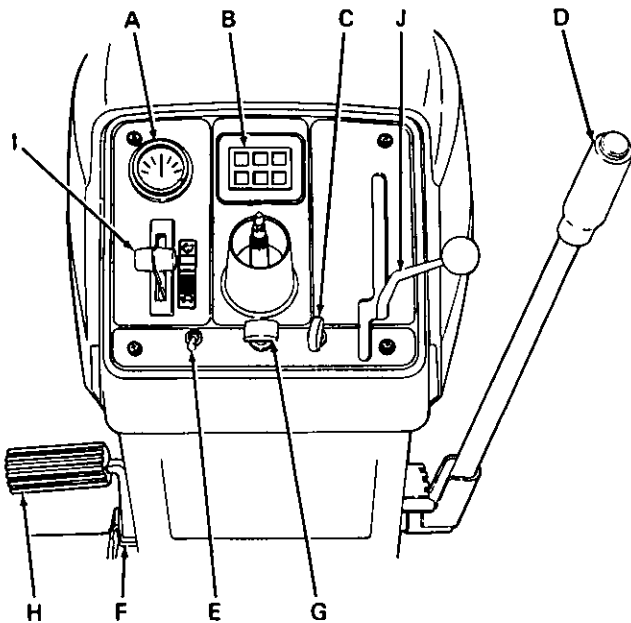

Figure 3

- A. Charge Indicator
- B. Electronic Monitor
- C. Ignition Switch/Light Switch
- D. Lift Handle
- E. Power Take-Off (PTO)
- F. Brake Pedal Lock
- G. Choke Control
- H. Brake/Clutch Pedal (1415 Tractor)  
Brake Pedal (1420 Tractor)
- I. Throttle Control Lever
- J. Gear Shift Lever (1415 Tractor)  
Speed Control Lever (1420 Tractor)

## B. ELECTRONIC MONITOR (Refer to Figure 4)

In Reverse Gear – will be illuminated when tractor is in reverse. Light must be off to start tractor.

Do Not Engage PTO – will be illuminated if PTO switch is engaged while tractor is in reverse.

## NOTE

PTO will not be engaged with tractor in reverse – switch only will engage.

PTO On – light will be illuminated when PTO switch is engaged. Light must be off to start tractor.

Place in Neutral – light will be illuminated when starting tractor and gear shift is not in neutral. Light must be off to start tractor.

Full Throttle Required (two indicators) – top light will be illuminated when the PTO is engaged. Bottom light will be illuminated when the light switch is on.

## NOTE

The unit should be run at full throttle when using PTO operated equipment or when the headlights are on.

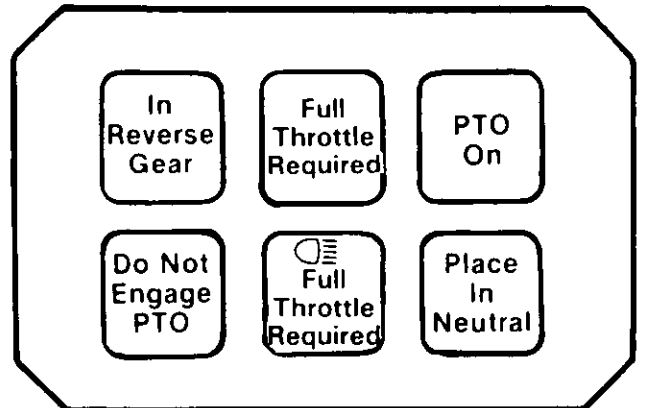

Figure 4

## C. IGNITION/LIGHT SWITCH

## NOTE

Remove the key from the tractor when the tractor is not in use to prevent accidental starting and battery discharge.

The combination lights and ignition switch is a four-position switch. (Refer to Figure 5.)

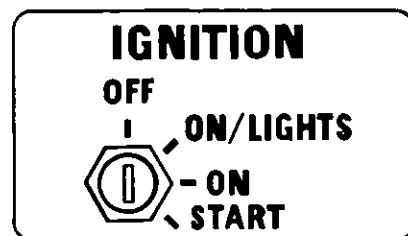

Figure 5



#### D. LIFT HANDLE

This lever is used to raise and lower equipment used with the tractor. The equipment can be set in six positions by depressing the button on the top of the lever and releasing it when the desired position is reached. (Refer to Figure 6).

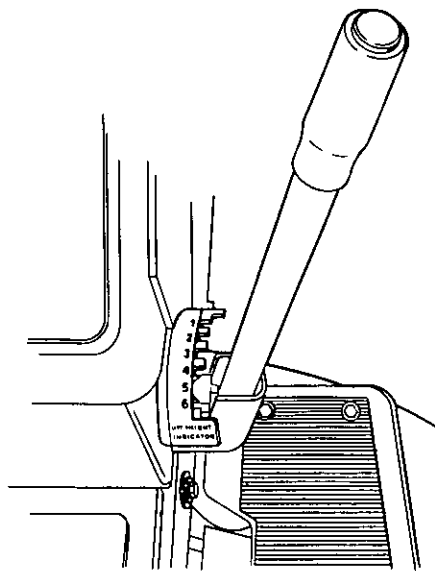

Figure 6

#### E. POWER TAKE-OFF (PTO)

The power take-off is an electric clutch operated by a toggle switch on the left side of the instrument panel. When PTO is engaged, throttle should be in fast position. (Refer to Figure 3.)

#### F. BRAKE PEDAL LOCK



#### WARNING

The hydrostatic transmission will not hold the tractor on a hill. In a short period of time (depending on the steepness of the hill) the oil will drain from the transmission and allow the tractor to roll downhill. To avoid an accident and/or possible injury, lock the brake.

Always lock the brake when tractor is parked on a grade. To lock the brake, depress brake/clutch pedal (1415 Tractor) or the brake pedal (1420 Tractor) and place the brake pedal lock in the engaged position. (Refer to Figure 7.) To disengage the lock, press down on the pedal, lift the lock up and place it in the disengaged position.

#### G. CHOKE CONTROL

The choke control is located on the instrument panel directly below the steering column. The choke control is operated manually. Pull knob out to choke engine. Push knob in to open choke. (Refer to Figure 3.)

#### H. BRAKE/CLUTCH PEDAL (1415 Tractor)

The brake/clutch pedal is located on the left side of the tractor. This pedal serves a dual purpose. When the brake/clutch pedal is slightly depressed, the drive belt is disengaged from the engine pulley. Fully depressing the brake/clutch pedal actuates the brakes to stop the tractor. (Refer to Figure 3.)

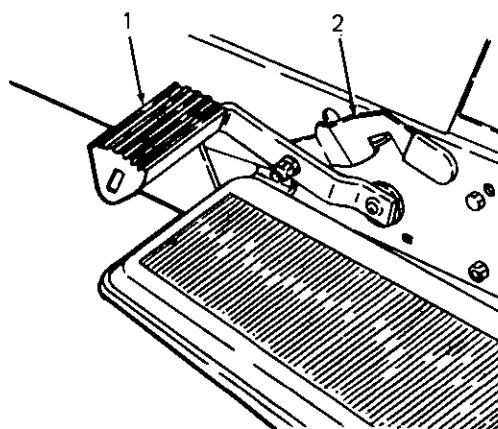

Figure 7

1. Brake/Clutch Pedal (1415 Tractor)  
Brake Pedal (1420 Tractor)
2. Brake Pedal Lock

#### I. BRAKE PEDAL (1420 Tractor)

The brake pedal is located on the left side of the tractor. When the pedal is fully depressed, the speed control lever is automatically moved to the neutral position. (Refer to Figure 3.)

#### J. THROTTLE CONTROL LEVER

This lever controls the speed of the engine. When set in a given position, it will maintain a uniform engine speed. (Refer to Figure 3.)

When using power take-off operated equipment, best performance is achieved with the throttle lever in the "FAST" position.



"Turtle" This symbol shows slow position.



"Rabbit" This symbol shows fast position.

### K. GEAR SHIFT LEVER (1415 Tractor)



Brake/clutch pedal should be slightly depressed before shift lever is moved.

The gear shift lever is located on the upper right hand side of the instrument panel. This lever is used to select various gear ratios provided in the transmission. There are five forward speeds and one reverse speed. Refer to "SPECIFICATIONS." (Refer to Figure 8.)

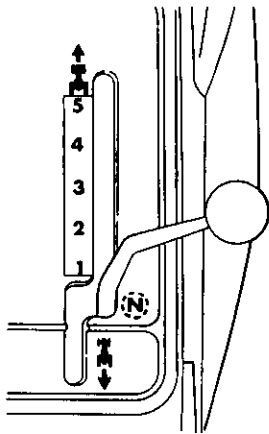

Figure 8

### L. SPEED CONTROL LEVER (1420 Tractor)

The speed control lever is located on the upper right hand side of the instrument panel. Move the speed control lever forward for various forward tractor speeds or backward for various reverse tractor speeds. (Refer to Figure 9.)

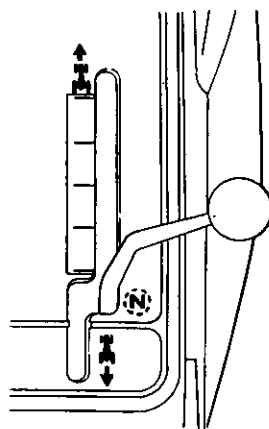

Figure 9

### M. INTERLOCKS

This tractor is equipped with a safety interlock system for the protection of the operator. If the interlock system should ever malfunction, do not operate the tractor. Contact your authorized *Cub Cadet* dealer.

The purpose of the safety interlock system is to prevent the engine from cranking or starting unless the gear shift lever (1415 Tractor) or speed control lever (1420 Tractor) is in the neutral ("N") position, the PTO switch is in the "OFF" position and the operator is seated.

If the operator leaves the seat when the PTO is on, or the unit is shifted into reverse when the PTO is on, the PTO will automatically disengage. To re-engage the PTO, shift into neutral ("N"), move PTO switch into the "OFF" position, and then reactivate PTO while seated.

### N. HYDROSTATIC DUMP VALVE LEVER (1420 Tractor)

The hydrostatic dump valve lever is located on the frame cover.

The dump valve disconnects the transmission from the pump so the unit can be pushed without running.

1. To engage the dump valve (making the tractor free-wheeling), push the lever forward and hold in this position. (Refer to Figure 10.)
2. To disengage the dump valve, release the lever. (Refer to Figure 11.)

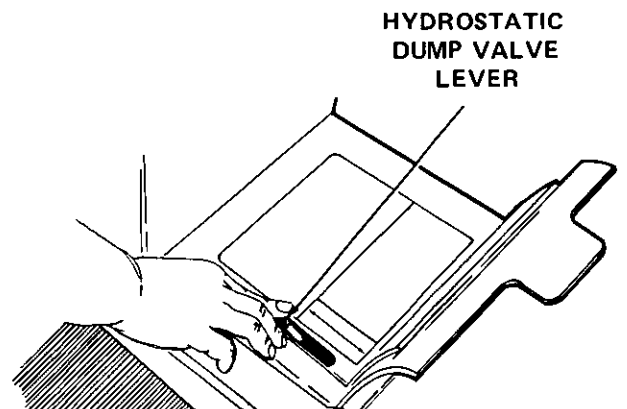

Figure 10

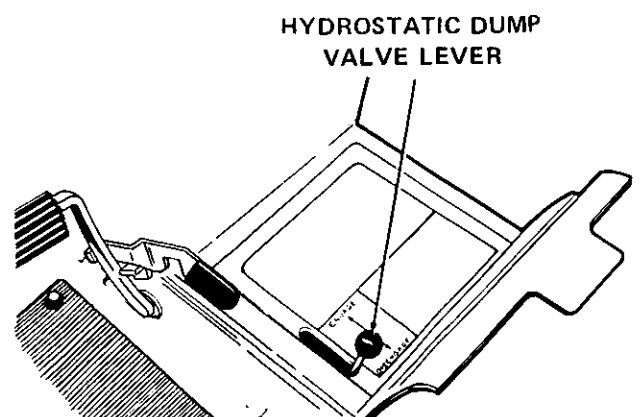

Figure 11

## FUEL TANK AND GAUGE

The fuel tank and gauge are located under the operator's seat. (Refer to Figure 12.)

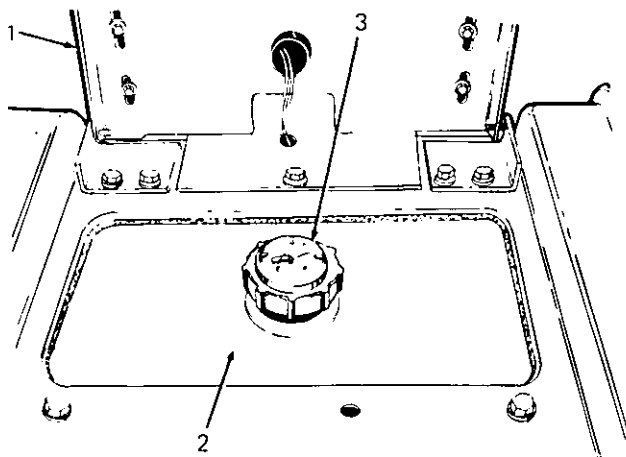

Figure 12

1. Operator's Seat
2. Fuel Tank
3. Fuel Tank Gauge

## FUEL SHUT-OFF VALVE

The fuel shut-off valve is located under the tractor's rear fender. The fuel shut-off valve is used to shut off fuel flow to the engine to aid maintenance. (Refer to Figure 13.)

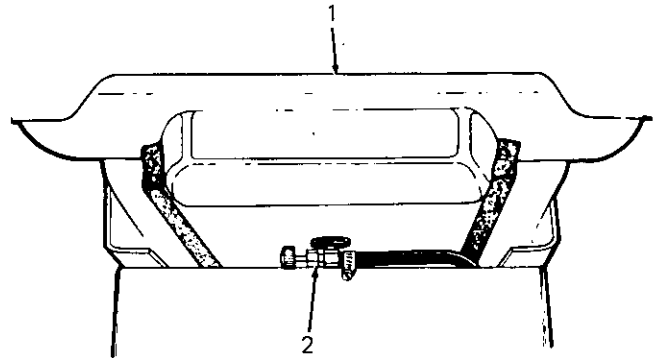

Figure 13

1. Rear Fender
2. Fuel Shut-Off Valve

# OPERATION

## PRE-OPERATION CHECKLIST

1. Check oil level. The oil fill and dipstick are located on the right rear side of the engine. (Refer to Figure 14.)
2. Fill fuel tank with Regular or Unleaded gasoline.

## ENGINE OIL REQUIREMENTS

### *Cub Cadet Low Ash Engine Oil*

Ambient Temperature	Viscosity (Grade SF)
Above 40°F	SAE 30
0° to 100°F	SAE 10W30 or 10W40
Below 20°F	SAE 5W20 or 5W30

**DO NOT USE:** Synthetic oil, non-detergent oil or other non-recommended oils.

**DO NOT MIX** different brands of oil.

## OIL DIPSTICK CHECKS

Dipstick should be checked before starting the unit **EVERY TIME**.

Dipstick markings indicate upper and lower limits at a cold oil condition.

Never overfill engine oil.

## OIL FILL DIPSTICK

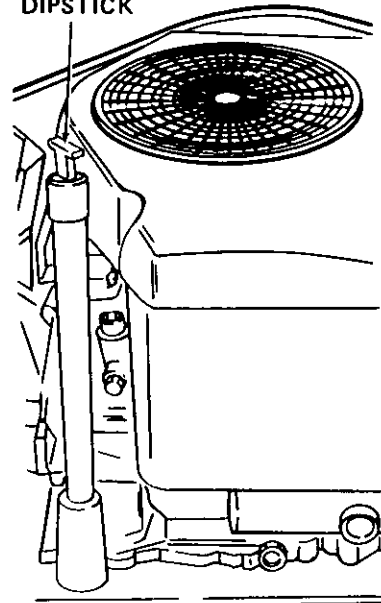

Figure 14

## BEFORE OPERATING YOUR TRACTOR

1. Before you operate the tractor study this manual carefully. It has been prepared to help you operate and maintain your tractor with utmost efficiency.

2. Familiarize yourself with the operation of all the instruments and controls.
3. Fill the tank with either lead-free, low-lead or regular gasoline. Make sure before you fill the tank that the gasoline is clean and fresh.
4. Check tire inflation pressures.
5. Adjust the seat for operator's maximum comfort, visibility and complete control of the tractor.
6. Refer to various sections of the Owner's Manual for additional information.

1. Operator must be seated.
2. Pull choke control button to full choke position. Less choking may be necessary due to variations in temperature, grade of fuel, etc. Little or no choking will be needed when the engine is warm.
3. Place the throttle in the "START" (1/2-3/4 throttle) position. Never start engine at full throttle.
4. Place the PTO switch to the "OFF" position.
5. Place the gearshift lever (1415 Tractor) or speed control lever (1420 Tractor) in neutral ("N").

## STARTING THE ENGINE



### WARNING

Do not operate tractor if the interlock system is malfunctioning. It is a safety device designed for protection of the operator.



### NOTE

This unit is equipped with a safety interlock system for your protection. The purpose of the safety interlock system is to prevent the engine from cranking or starting unless the gear shift lever (1415 Tractor) or speed control lever (1420 Tractor) is in neutral ("N"), the PTO switch is in the "OFF" position and the operator is seated. If the operator leaves the seat when the PTO is on, or the unit is shifted into reverse when the PTO is on, the PTO will automatically disengage.



### WARNING

During operation do not run the engine in confined area such as storage building any longer than is necessary. Immediately move the tractor outside into the air.



### NOTE

When the engine is still cold it is acceptable to run the unit with the choke pulled out 1/4 inch until the engine is warmed up to prevent engine misfiring.



### NOTE

Make sure the carburetor is adjusted as instructed on page 19.



### NOTE

On the 1420 model tractors, the speed control lever will automatically return to neutral when the brake pedal is pressed all the way down, and the linkage is properly adjusted.

6. Turn the ignition key clockwise to the "START" position and release it as soon as the engine starts: however, do not operate the starter for more than 10 seconds at any one time. If the engine does not start within this time, turn the key "OFF" and wait a few minutes, then try again.
7. After the engine starts, slowly release the brake/clutch pedal (1415 Tractor) or brake pedal (1420 Tractor) and gradually push the choke control button all the way in. Do not use the choke to enrich the fuel mixture, except as necessary to start the engine.

## STOPPING THE ENGINE



### CAUTION

Remove the key to prevent accidental starting and battery discharge if equipment is left unattended.

1. Return gear shift lever (1415 Tractor) or speed control lever (1420 Tractor) to neutral ("N"), engage the brake pedal lock and return PTO to "OFF" position.
2. Move the throttle lever 1/2 way between the "SLOW" and "FAST" positions and allow the engine to idle for a minimum of 15 seconds before stopping.
3. Then turn the key to the "OFF" position. Remove key from ignition switch.

## COLD WEATHER STARTING



### WARNING

During operation do not run the engine in confined area such as storage building any longer than is necessary. Immediately move the tractor outside into the air.



### NOTE

In cold weather the starting motor may disengage prematurely. This is caused by the engine firing once but failing to continue running. If this happens several times, the engine will be flooded and it will be necessary to leave the throttle in the "SLOW" position but push the choke in all the way; then turn the ignition key to the "START" position and slowly pull the choke out to the position which will cause the engine to start and continue running. If the engine falters after putting tractor into motion, pull the choke out part way until the engine runs smoothly, then gradually push the choke back in as the engine warms.

Engine starting is possible in cold weather providing the correct weight of engine oil is used, the battery is fully charged, and the proper starting procedure is followed. The best procedure for starting at temperatures near or below freezing is as follows:

1. Pull the choke all the way out into the full choke position.
2. Place the throttle in the "START" (1/2-3/4 throttle) position. Never start engine at full throttle.
3. Make sure the gear shift lever (1415 Tractor) or speed control lever (1420 Tractor) is in neutral ("N") and the PTO switch is in the "OFF" position.
4. Move the key switch into the "START" position and hold until the engine starts; however, do not operate the starter for more than 10 seconds at any one time. As soon as the engine starts, slowly push the choke in part way.

## OPERATING IN COLD WEATHER



### NOTE

When the engine is still cold it is acceptable to run the unit with the choke pulled out 1/4 inch until the engine is warmed up to prevent engine misfiring.

## DRIVING THE TRACTOR (1415 Tractor)



### CAUTION

DO NOT shift gears while the engine clutch is engaged or while tractor is moving.



### CAUTION

The brake/clutch pedal should be pushed slightly down in order to change gears.



### CAUTION

Do not leave the seat of the tractor without depressing the brake/clutch pedal and engaging the brake pedal lock. If leaving the tractor unattended, also turn the ignition key off and remove the key.



### CAUTION

Avoid sudden starts, excessive speed and sudden stops. Keep vehicle in gear when going down hills.



### CAUTION

Do not rest your foot on the brake/clutch pedal while driving the tractor. This will lead to premature and excessive wear of the belt.



### NOTE

When using power take-off operated equipment, best performance is achieved with the throttle lever in the "FAST" position.

1. Disengage the drive belt by pressing the brake/clutch pedal all the way down, and release the brake pedal lock. Move the gearshift lever to the desired speed.
2. Start the tractor in motion by slowly releasing the brake/clutch pedal and moving the throttle lever to the position where the engine operates best for the load to be handled. If smooth engagement cannot be obtained, an adjustment to the clutch rod may be required.

## DRIVING THE TRACTOR (1420 Tractor)



### CAUTION

Avoid sudden starts, excessive speed, and sudden stops. Keep tractor in gear when going down hills.



### CAUTION

Do not leave the seat of the tractor without depressing the brake pedal and engaging the brake pedal lock. If leaving the tractor unattended, also turn the ignition key off and remove the key.



### NOTE

When using power take-off operated equipment, best performance is achieved with the throttle lever in the "FAST" position.

1. Depress the brake pedal and release the brake pedal lock. Move the throttle lever to the position where the engine operates best for the load to be handled. Release the brake pedal.
2. Start the tractor in motion by moving the speed control lever slowly forward or rearward to desired speed.

**DRIVING ON SLOPES** (Refer to "SLOPE GAUGE" on page 35 in order to help determine slopes where you may not operate safely.)



### WARNING

Do not mow on inclines with a slope in excess of 15 degrees (a rise of approximately 2-1/2 feet every 10 feet). A riding mower could overturn and cause serious injury.



### WARNING

Operate RIDING mowers up and down slopes, never across slopes.



### CAUTION

Always drive up or down the face of a slope. Do not drive so that the tractor may tip over sideways.

Before operating the tractor on any slope, walk the slope to look for possible hazards such as rocks, mounds, ruts, stumps or other surface irregularities which could cause an upset.

Back the tractor with implement up the steepest portion of each slope you intend to work. If the tractor cannot negotiate the slope in reverse, the slope is too steep to be worked.

Avoid turns when driving on a slope. If a turn must be made, turn down the slope. Turning up a slope greatly increases the chance of a roll over.

Avoid stopping when driving up a slope. If it is necessary to stop while driving up a slope, start up smoothly and carefully to reduce the possibility of flipping the tractor over backward.

## STOPPING THE TRACTOR (1415 Tractor Only)



### CAUTION

Always engage brake pedal lock, lower equipment and shut off engine before dismounting. Never try to start engine from ground.

Disengage the drive belt by pressing the brake/clutch pedal slightly down. Move gear shift lever to the "N" position and fully depress the brake/clutch pedal to stop.

## STOPPING THE TRACTOR (1420 Tractor Only)



### CAUTION

Always engage brake pedal lock, lower equipment and shut off engine before dismounting. Never try to start engine from ground.

Move the speed control lever to the "N" position and/or push brake pedal all the way down.



### NOTE

On the 1420 model tractors, the speed control lever will automatically return to neutral when the brake pedal is pressed all the way down, and the linkage is properly adjusted.

Before dismounting, always engage the brake pedal lock and turn the ignition "OFF." Also disengage the PTO switch.

## OPERATING THE FRONT POWER TAKE-OFF CLUTCH (PTO) (Refer to Figure 15.)

1. Move the throttle lever back to the medium or "SLOW" position.
2. Flip the toggle switch to the "RUN" (C) position.
3. Advance throttle to operating speed (full speed).
4. The operator must remain in tractor seat at all times. If operator should leave tractor seat without turning off the power take-off switch, the PTO will disengage.
5. PTO switch must be in the "OFF" (A) position when shifting the tractor into reverse or the PTO

will disengage automatically. To re-engage the PTO, shift unit into neutral. Move PTO switch to "OFF" (A) position. Then pull knob out and lift up to "START" (B) position and release.

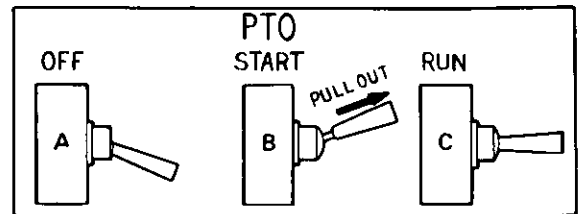

Figure 15

## ADJUSTMENTS

### ADJUSTING THE SEAT

Before starting the tractor, adjust the seat to the most comfortable driving position. Tilt the seat forward over the steering wheel, loosen the four cap screws in the seat support, and slide the seat assembly forward or rearward to the position which is most comfortable for the operator. (Refer to Figure 16.)

Retighten the cap screws after the seat is adjusted.

### FRAME COVER REMOVAL

To remove the frame cover, the seat assembly must be removed.

1. Remove two screws from one seat bracket. Slide seat assembly off the pin on the other seat bracket.
2. Remove screw and flat washer from frame cover as shown in Figure 16.
3. Remove two screws holding frame cover to frame in the step through area (not shown).
4. Remove ball knob from end of dump valve (on 1420 Tractor only).
5. Disconnect seat switch to harness.
6. Lift up and slide frame cover rearward from underneath the pedestal.
7. Reassemble frame cover and seat assembly in reverse order. Make certain all screws are tightened securely.

### CLUTCH ROD ADJUSTMENT (1415 Tractor)

Clutch rod adjustment is necessary when belt slippage occurs, or when brake/clutch pedal bottoms out on the running board and does not return to the up position. If adjustment is needed, contact your authorized dealer.

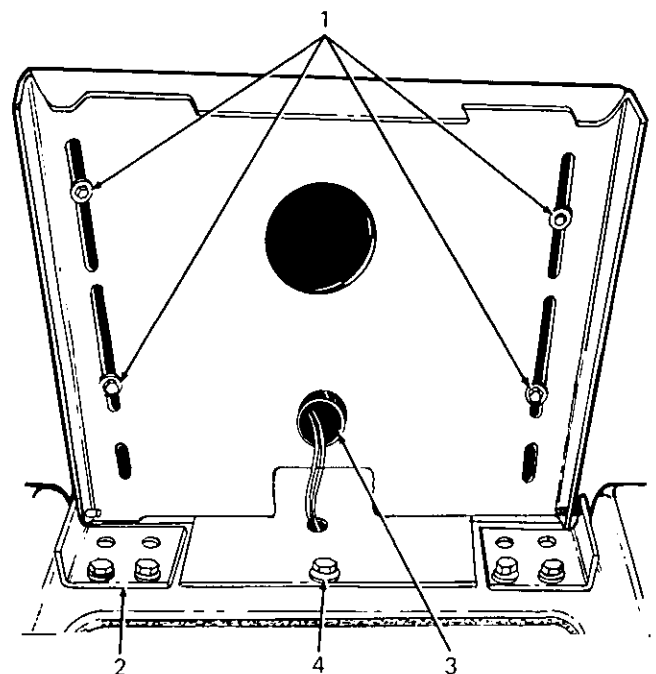

Figure 16

1. Seat Adjustment Bolts
2. Seat Bracket
3. Seat Switch
4. Screw On Frame Cover

## ADJUSTING THE POWER TAKE-OFF CLUTCH



### WARNING

To avoid possible injury, always disengage all clutches, move speed control or gear shift lever into neutral, depress the brake, set the brake pedal lock and turn the ignition "OFF" before working on the machine.

The clutch is factory adjusted and should not require further adjustment under normal operating conditions. However, if the clutch fails to operate properly, check as follows:

Using a feeler gauge, check the air gap. (Refer to Figure 17.) Insert feeler gauge into one of three access slots located around the outside of the brake plate. The air gap should be .010 to .015 inch. Adjust the self-locking nuts to obtain the proper clearance. Repeat the operation in all three access slots.

**NOTE**

If brake plate drags on clutch at .010 to .015 inch air gap, increase air gap to .020 inch. After two hours of use, recheck and set back to .010 to .015 inch.

If the above procedure does not work, see your authorized dealer.

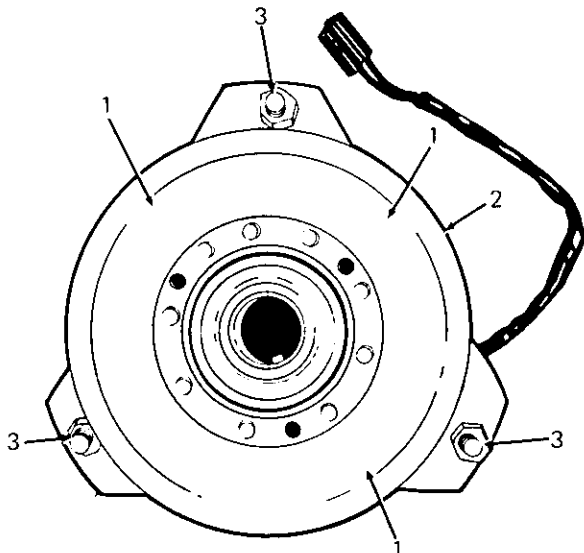

Figure 17

1. Access Slots
2. Brake Plate
3. Self-Locking Nuts

**ADJUSTING THE BRAKES (1415 Tractor)**

During normal operation on this machine, the brakes are subject to wear and will require periodic examination and adjustment.

To check brake adjustment, position the tractor on a level surface, place the gear shift lever in neutral ("N") position and perform the following checks:

1. Engage the brake pedal lock. If the unit can be pushed forward or rearward, the brake force must be increased.
2. Release the brake pedal lock. If the unit cannot be pushed forward or rearward, brake force must be decreased.

Refer to the following instructions to increase or decrease brake force.

To increase brake force, refer to Figure 18 and proceed as follows:

1. Place the tractor on a level surface, with the brake pedal lock disengaged.
2. Tighten the top lock nut 1/4 turn at a time until tractor free movement begins to bind. Then back off the top lock nut 1/4 turn.

**NOTE**

If the previously described brake adjustment does not result in efficient brake operation, proceed to step number 3.

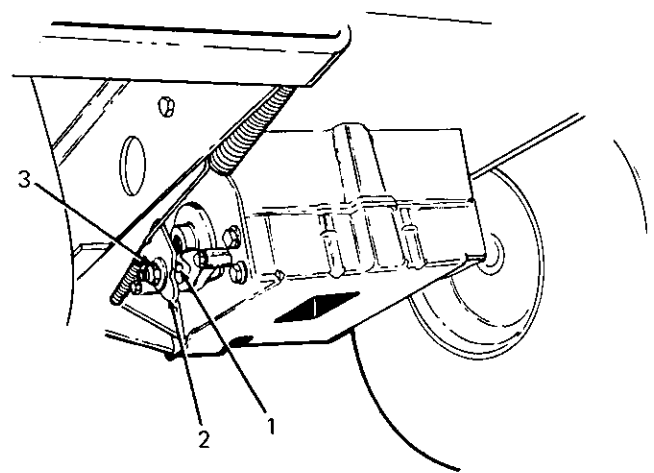

Figure 18

1. Stop Bolt
2. Cam Lever
3. Top Lock Nut

3. Refer to Figure 19 and tighten the hex nut on the end of the brake rod, under the spring as follows: remove the hairpin cotter and flat washer from the other end of the brake rod to disconnect it, and tighten the hex nut.
4. Reconnect the brake rod and secure it with flat washer and hairpin cotter.

Recheck the adjustment making certain correct adjustment is reached before operating the tractor.

To decrease brake force, refer to Figure 19 and proceed as follows:

1. Loosen the hex nut on the end of the brake rod under the spring as follows: remove the hairpin cotter and flat washer from the other end of the brake rod to disconnect it, and loosen the hex nut.



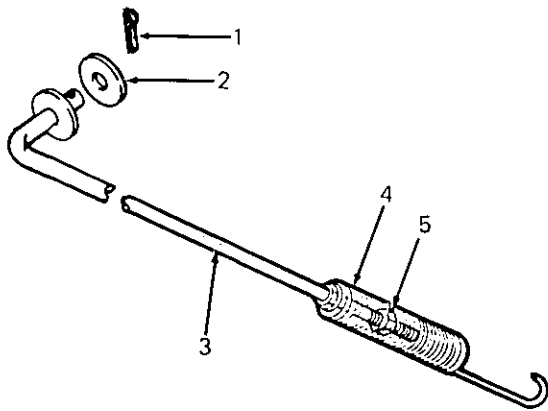

Figure 19

1. Hairpin Cotter
2. Flat Washer
3. Brake Rod
4. Spring
5. Hex Nut

**NOTE**

At least 3 threads on the end of the brake rod must remain visible following this adjustment.

2. Reconnect the brake rod and secure it with flat washer and hairpin cotter.

Recheck the adjustment making certain correct adjustment is reached before operating the tractor. If the tractor still cannot be pushed following this adjustment, and with the brake pedal lock released, see your authorized *Cub Cadet* Dealer.

**ADJUSTING THE BRAKES (1420 Tractor)**

During normal operation of this tractor, the brakes are subject to wear and will need periodic examination and adjustment.

To check the brake adjustment, place tractor on a level surface, and engage the hydrostatic dump valve so unit can be pushed. Perform the following checks:

1. Engage the brake pedal lock [when the brake pedal is fully depressed, and the linkage is properly adjusted, the speed control lever will automatically move to the neutral ("N") position]. If the unit can be moved forward or rearward, the brake force must be increased.
2. Release the brake pedal lock. If the unit cannot be moved forward or rearward, the brake force must be decreased.

Refer to the following instructions to increase or decrease brake force.

To increase the brake force, refer to Figure 20 and proceed as follows:

1. Place the tractor on a level surface, with the brake pedal lock disengaged.
2. While working from the rear of the tractor, turn the nut located on the end of the brake rod, clockwise one full turn at a time, until correct adjustment is achieved.

Recheck the adjustment making certain correct adjustment is reached before operating the tractor. If the tractor can still be pushed with brake pedal locked and dump valve engaged, see your authorized *Cub Cadet* Dealer.

To decrease brake force, refer to Figure 20 and proceed as follows:

1. While working from the rear of the tractor, turn the nut located on the end of the brake rod, counterclockwise one full turn at a time, until correct adjustment is achieved.

Recheck the adjustment, making certain correct adjustment is reached before operating the tractor. Following this adjustment, release the brake pedal lock and engage the dump valve. If the tractor still cannot be pushed, see your authorized *Cub Cadet* Dealer.

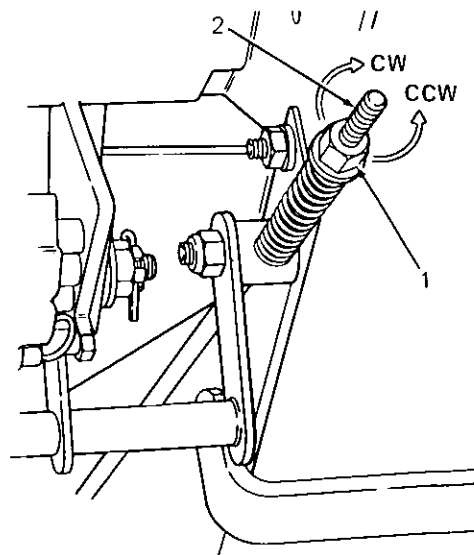

Figure 20

1. Nut
2. Brake Rod

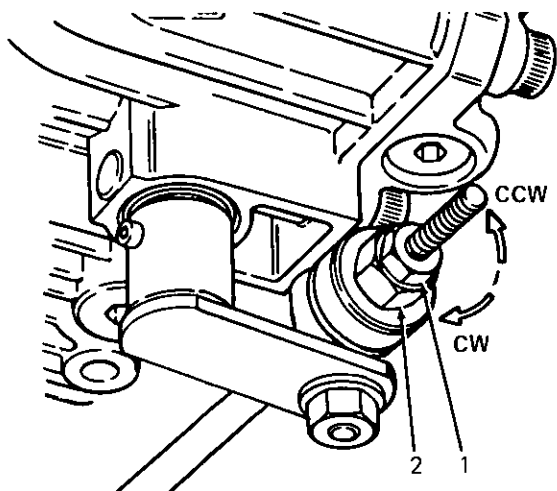

Figure 21

1. Jam Nut
2. Control Assembly

#### HYDROSTATIC CONTROLS AND ADJUSTMENT (1420 Tractor)



#### CAUTION

On the 1420 model tractors, the speed control lever will automatically return to neutral when the brake pedal is pressed all the way down, and the linkage is properly adjusted. If this action fails to occur, contact your authorized *Cub Cadet* Dealer for immediate service.

The following adjustment may be necessary for the hydrostatic adjustment rod if the tractor creeps forward or rearward while the speed control lever is in the neutral ("N") position. Refer to Figure 21 and while working from rear of tractor with unit off, proceed as follows:

1. If the tractor creeps forward, loosen the jam nut and turn the hex on the control assembly counterclockwise until tractor creep is stopped. When correct adjustment is achieved, retighten jam nut.
2. If the tractor creeps rearward, loosen jam nut and turn the hex on the control assembly clockwise until tractor creep is stopped. When correct adjustment is achieved, retighten jam nut.

#### NOTE

If condition is not corrected after performing the above steps, see your authorized *Cub Cadet* Dealer for service.

#### PIVOT BAR ADJUSTMENT BOLTS



#### CAUTION

The tractor must be checked every 50 hours of tractor operation for play between the front axle and the pivot bar adjustment bolts. Both adjustment bolt heads must fit against the front axle. If play is discovered, the pivot bar adjustment bolts must be adjusted.

If play is discovered between the front axle and the pivot bar adjustment bolt heads, adjust both bolts as follows: (Refer to Figure 22.)

1. Loosen jam nut 3 to 4 turns or as required.
2. Turn pivot bar adjustment bolt counterclockwise until it hits against the front axle.
3. Tighten jam nut.
4. Repeat the above steps for the other pivot bar adjustment bolt.

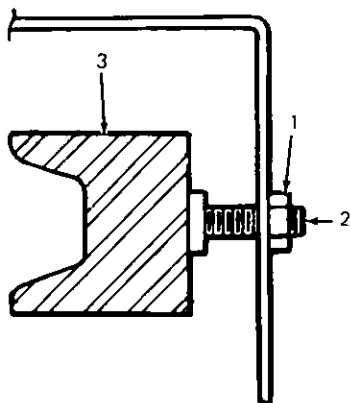

SECTION A-A

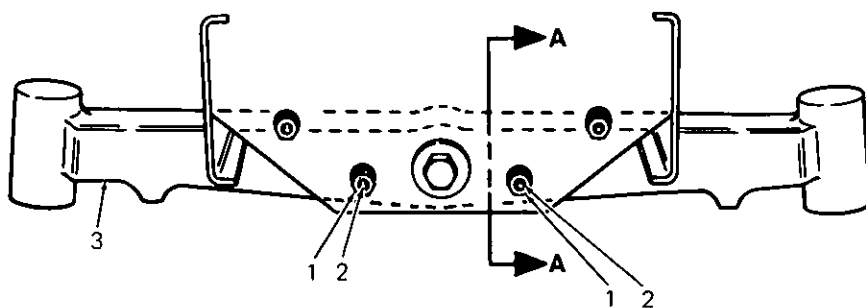

Figure 22

1. Jam Nut
2. Pivot Bar Adjustment Bolts
3. Front Axle

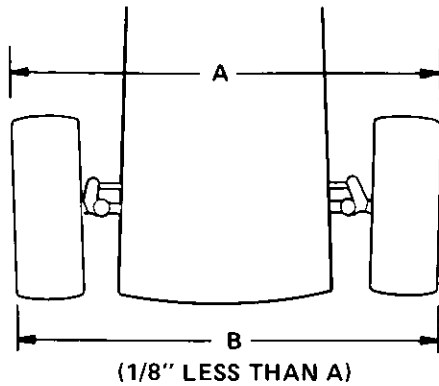

Figure 23

### WHEEL ALIGNMENT

The front wheels should toe-in approximately 1/8 inch.

Measure the distances A and B on the front wheels. (Refer to Figure 23.)



Dimension B should be approximately 1/8 inch less than dimension A.

### FRONT WHEEL ADJUSTMENTS

To adjust the toe-in remove one ball joint, loosen lock nuts "C" at the ball joint and turn the tie rod ball joint in or out as required. (Refer to Figure 24.)



Tie rod has a bend in the center for clearance of castle nut on pivot bar. Bend must remain down as shown in Figure 24.

### TURNING RADIUS



Be sure all parts are tightened after completing the following adjustment.

The front wheels should have an equal angle for left and right turns. If adjustment is necessary, remove ball joint and loosen lock nut "D." (Refer to Figure 24.) Turn the drag link ball joint clockwise or counter-clockwise as required.

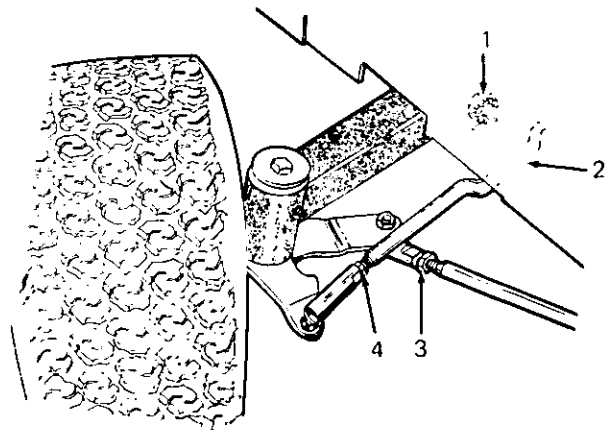

Figure 24

### Tie Rod and Drag Link Ball Joints

1. Castle Nut at Pivot Bar
2. Bend in Tie Rod
3. Lock Nut "D"
4. Lock Nut "C"

### CARBURETOR ADJUSTMENTS (Refer to Figure 25)



If any adjustments are made to the engine while the engine is running (e.g., carburetor), disengage all clutches and blades. Keep clear of all moving parts and be careful of heated surfaces and mufflers.



To avoid injury or an accident, be sure the brake pedal is in the locked position, transmission is in neutral, and any equipment is disengaged before starting engine to make carburetor adjustments.



Carbon monoxide fumes can be fatal! Do not make any adjustments to the carburetor in a confined area such as a storage building. Move the tractor outside into the air.

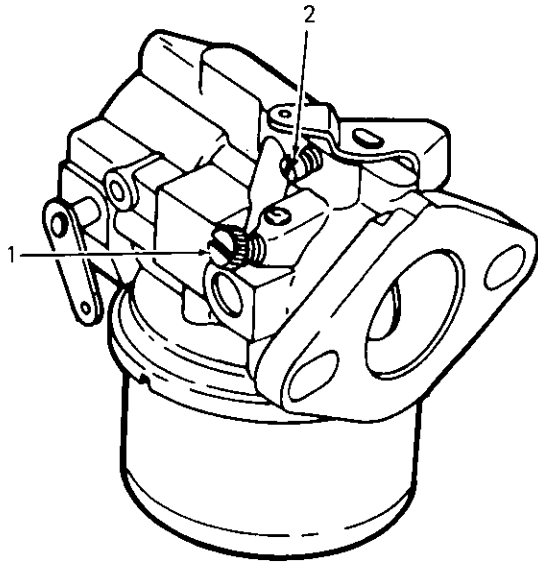

Figure 25

1. Idle Fuel Adjustment Screw
2. Idle Speed Adjustment Screw

The carburetor is adjusted at the factory and under normal operating conditions it will not require readjusting. However, if the engine does not operate properly, what may appear to be a faulty carburetor adjustment is in many cases a clogged air filter. This possibility should be ruled out before attempting to readjust carburetor. Refer to "MAINTENANCE" section in this manual.

To prevent possible damage to the carburetor needles, be very careful closing the carburetor needles before basic adjustments are made. Improper adjustment of the carburetor may result in engine damage.

#### IDLE SPEED ADJUSTMENT

Run engine at maximum governed, no load speed for a minimum of 30 seconds, then allow engine speed to fall to idle or put throttle into idle position. Set engine speed to 1800 (+ or - 75 RPM) by turning the idle speed screw in or out.

#### IDLE FUEL ADJUSTMENT

Set the idle fuel mixture by turning the idle fuel screw out, from the closed position, 1-1/4 to 1-3/8 turns.

## MAINTENANCE

#### ENGINE OIL

The engine crankcase is filled with ship-away oil. This oil may be used for the first 5 hours of engine operation at temperatures between 0 degrees F. and 90 degrees F. If temperatures are not within this range, drain the oil from the oil filter, if installed, and crankcase and replace with new oil as specified in the "LUBRICATION TABLE." The engine oil must be drained and replaced with new oil every 25 hours of engine operation.

#### NOTE

With the optional oil filter service kit (KH-52-702-02, available from your authorized *Cub Cadet* Dealer) installed on your tractor, oil service intervals can be increased to 50 hours between oil and oil filter changes.

To aid starting, the selection of crankcase lubricating oils should be based on the lowest anticipated temperatures until the next drain period.

*Cub Cadet* Low Ash Engine Oil meeting API Service Classification SF is recommended. For maximum engine life select API SF oils with lowest levels of barium, calcium, or magnesium additives and minimum ash content (approximately 0.5%). Lubricant suppliers will normally furnish this information on their engine oils.

Multi-viscosity numbered oils such as SAE 10W-30 or SAE 10W-40 can be used above 32 degrees Fahrenheit.

## OIL LEVEL CHECK

Before each use, the oil level of the engine crankcase should be checked to see that it is filled to correct level. Close monitoring of the oil level during the first 10 hours of operation of the engine is especially important. Always keep the oil level between the "FULL" and the "LOW" marks on the dipstick. When checking the oil level the dipstick must be withdrawn and wiped clean, then inserted all the way and withdrawn for a true reading.



Check the oil level only while the engine is stopped and tractor is level.



The oil level should be checked every hour during the first 5 hours of operation.



The engine oil level should be checked prior to every use.

## FILLING THE CRANKCASE

To fill the crankcase with oil, place the tractor on a level surface. Clean the area around the oil fill tube and dipstick to prevent debris from entering the crankcase.



Never overfill the engine crankcase. Engine may overheat and/or damage may result if the crankcase is below the "LOW" mark or over the "FULL" mark. For oil capacity refer to the **SPECIFICATIONS** and **LUBRICATION TABLE** sections.

Remove the oil fill cap and dipstick and fill to the full mark on the dipstick. **POUR SLOWLY.** The oil capacity is 3-1/2 pints without an oil filter service kit installed, and 4 pints with the kit installed. When checking the oil level, push the dipstick assembly firmly but slowly until cap bottoms on tube. **DO NOT OVERFILL.** Dipstick assembly **MUST BE PUSHED FULLY INTO TUBE AT ALL TIMES WHEN ENGINE IS OPERATING.**

## OIL CHANGE PROCEDURE



The engine oil should be changed after the first 5 hours of operation.

Refer to the **MAINTENANCE CHART** and the **LUBRICATION TABLE** for information regarding the frequency of oil change and the quantity and type of oil needed. While the engine oil is warm, proceed as follows:



Oil may be hot. Use care to avoid burns from hot oil.

1. Place the tractor on a level surface, and engage brake pedal lock. Remove the drain plug and collect the old oil in an adequate container. (Refer to Figure 26.)



If the optional oil filter kit has been installed, proceed with steps 2 and 3. If no oil filter is installed, proceed with step 4.

2. Remove the oil filter by turning it counterclockwise.
3. Apply a light coat of oil to rubber seal on oil filter. Install filter turning it clockwise. Filter should be snug plus 1/2 turn.
4. Replace the drain plug.
5. Refer to **"FILLING THE CRANKCASE"** and **"LUBRICATION GUIDE"** and refill the crankcase.

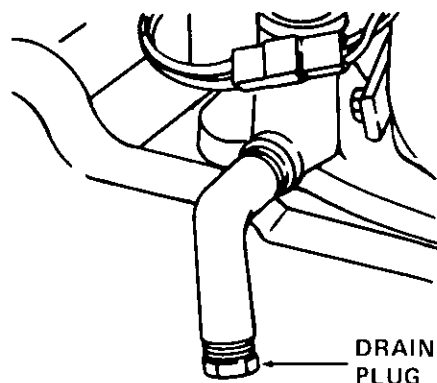

Figure 26

## AIR CLEANER

### Servicing Foam Pre-Cleaner Element

Clean and re-oil foam pre-cleaner element at 1-month intervals or every 10 hours, whichever occurs first.



Service more often under dusty conditions.

1. Remove wing nut and cover. (Refer to Figure 27.)
2. Remove foam pre-cleaner element by sliding it up off the paper cartridge.
  - A. Wash pre-cleaner element in liquid detergent and water.
  - B. Squeeze dry in cloth.
  - C. Saturate in engine oil. Squeeze to distribute oil evenly.
  - D. Wrap in shop towel and squeeze to remove excess oil.

Discard used element and replace with new one at least once a year.

### SERVICING PAPER CARTRIDGE

This engine is equipped with a dry type air cleaner element, which should be checked every 100 operating hours and replaced if dirty. It should be checked and if necessary replaced more often under extremely dirty, dusty conditions. Do not wash element in any liquid or attempt to blow dirt off with air hose as this will puncture filter element. Carefully handle new element — do not use if gasket surfaces are bent or twisted. Check the following when installing a new element: (Refer to Figure 27.)

1. Backplate must be flat on gasket of carburetor elbow. Replace backplate if bent or cracked.
2. Gasket surfaces of element must be flat against backplate and covered to seal effectively.
3. Seal on cover must be in place to reduce noise and vibration of the cover. Vibration can cause stud hole in cover to enlarge, thus permitting dirt to enter carburetor.
4. Wing nuts must be finger tight — do not over-tighten.

Properly cleaned and installed air cleaner elements are the best guarantee to continued long and satisfactory engine life.

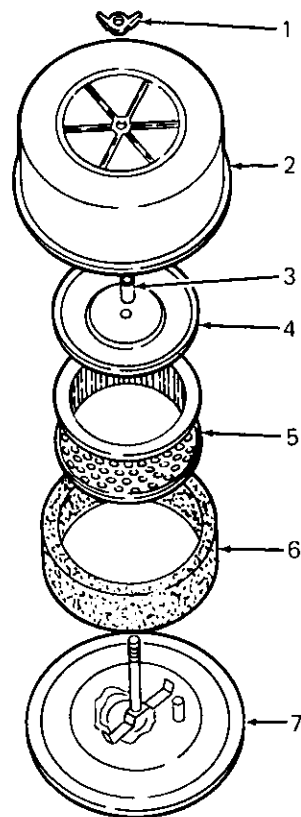

Figure 27. Air Cleaner Assembly

1. Wing Nuts
2. Cover
3. Rubber Tube
4. Cover Plate
5. Paper Cartridge
6. Foam Pre-Cleaner Element
7. Base Backplate

### CLEANING ENGINE

This tractor has an air-cooled engine. Air must be able to circulate freely around the engine, through the screen, shroud, and over the fins of the cylinder head and cylinder block. Keep these areas free of accumulated dirt and trash or engine will overheat and result in damaged moving parts.

### SPARK PLUGS



### WARNING

To avoid possible injury, be sure engine is off and cool before making any adjustment or repairs.



Remove all dirt from around the spark plugs before removing.

To remove spark plugs, always use a spark plug wrench. Check gap after every 100 hours of operation.

Replace a defective plug with a new plug. Set gap at .025 inch. (Refer to Figure 28.) Tighten plug to 10-15 ft-lbs. See your authorized dealer for the correct replacement plug.

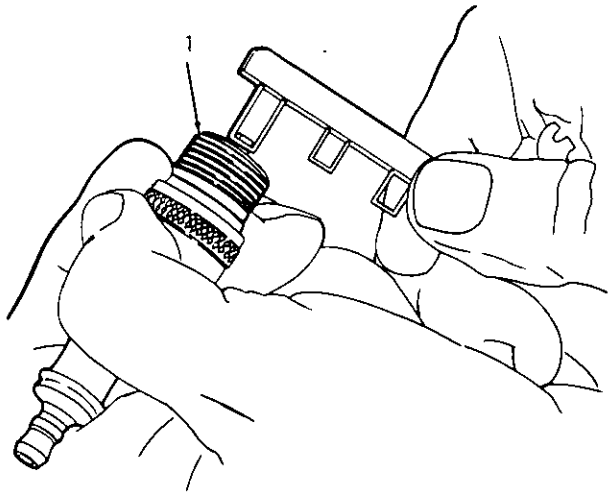

Figure 28

#### 1. Spark Plug

#### CLEANING OF CYLINDER HEADS

Cleaning of the cylinder heads should only be done by your authorized *Cub Cadet* Dealer. This process is to be done to keep your engine properly cooled and at its peak efficiency. The frequency of cleaning is dependent upon the type of fuel used. When leaded fuel is used the cleaning interval is 250 hours, and with unleaded fuel the cleaning interval is 500 hours.

#### FIVE SPEED TRANSMISSION (1415 Tractor)

The transmission is lubricated and sealed at the factory and does not require checking. If disassembled for any reason, lubricate with 24 ounces of E.P. Lithium grease.

#### HYDROSTATIC TRANSAXLE (1420 Tractor)

This is a sealed unit. It should only be serviced by an authorized *Cub Cadet* Dealer.

#### HYDROSTATIC TRANSMISSION (1420 Tractor)

This is a sealed unit. It should only be serviced by an authorized *Cub Cadet* Dealer.

#### DRIVE BELT REPLACEMENT

If drive belt replacement is required, contact your authorized *Cub Cadet* Dealer.

#### BATTERY INFORMATION



#### WARNING

- A. Battery acid must be handled with great care as contact with it can burn and blister the skin. It is also advisable to wear protective clothing (goggles, rubber gloves and apron) when working with it.\*
  - B. Should battery acid accidentally splatter into the eyes or onto the face, rinse the affected area immediately with clean cold water. If there is any further discomfort, seek prompt medical attention.
  - C. If acid spills on clothing, first dilute it with clean water, then neutralize with a solution of ammonia/water or baking soda/water.
  - D. Since battery acid is corrosive, do not pour it into any sink or drain. Before discarding empty electrolyte containers, rinse them with a neutralizing solution.
  - E. NEVER connect or disconnect charger clips to battery while charger is turned on as it can cause sparks.
  - F. Keep all lighted materials (cigarettes, matches, lighters) away from the battery as the hydrogen gas generated during charging can be combustible.
  - G. As a further precaution, only charge the battery in a well-ventilated area.
- \* Always shield eyes and protect skin and clothing when working near batteries.



#### DANGER

BATTERIES CONTAIN SULFURIC ACID AND MAY CONTAIN EXPLOSIVE GASES (when electrolyte has been added).

KEEP BATTERIES OUT OF THE REACH OF CHILDREN.

## MAINTENANCE OF BATTERY

1. Check electrolyte level periodically (at least every two weeks). Keep the level to the split rings. Use only distilled water or a good quality drinking water. Never add acid or any other chemicals to the battery after initial activation.
2. The battery should be checked with a hydrometer after every 25 hours of operation. If the specific gravity is less than 1.225, the battery should be recharged. Maximum charge rate 5 amps.
3. Coat the terminals and exposed wire with a thin coat of grease or petroleum jelly for longer service and protection against corrosion.
4. The battery should be kept clean. Any deposits of acid should be neutralized with baking soda and water. Be careful not to get this solution in the cells.
5. Avoid tipping the battery. Even a "sealed" battery will leak electrolyte when tipped.

## STORAGE OF THE BATTERY

1. When storing battery for extended periods, disconnect battery cables. Removing battery from unit is recommended.
2. Keep the exterior of the battery clean, especially the top. A dirty battery must be stored with a full charge. A dirty battery will discharge itself.
3. Check the battery with a hydrometer. The battery must be stored with a full charge. A discharged battery will freeze.

### Specific Gravity

1.265  
1.250  
1.200  
1.150  
1.100

### Freezing Point

-71°F  
-62°F  
-16°F  
5°F  
16°F



## NOTE

All batteries discharge during storage.

4. Recharge battery whenever the specific gravity is less than 1.225, before returning to service or every two months, whichever comes first.

## COMMON CAUSES FOR BATTERY FAILURE

1. Overcharging
2. Undercharging
3. Lack of water
4. Loose hold downs and/or corroded connections
5. Excessive loads
6. Battery electrolyte substitutes
7. Freezing of electrolyte



## NOTE

These failures do not constitute warranty.

## BATTERY REMOVAL OR INSTALLATION



## WARNING

When removing the battery, follow this order of disassembly to prevent your wrench from shorting against the frame.

1. Remove the Negative cable.
2. Remove the Positive cable.

### To install a battery:

1. Attach the Positive cable.
2. Attach the Negative cable.

## JUMP STARTING



## WARNING

Failure to use this starting procedure could cause sparking, and the gases in either battery could explode.

1. Attach the first jumper cable from the positive terminal of the good battery to the positive terminal of the dead battery.
2. Attach the second jumper cable from the negative terminal of the good battery to the FRAME OF THE UNIT WITH THE DEAD BATTERY.



## TIRES

Keep the pneumatic tires properly inflated. Overinflation will cause operator discomfort. Underinflation will cause short tire life.

Inflate the front and rear tires for normal or heavy load operations as shown in the following table:

Tire Size	Pounds per Square Inch
Front Tires 15 x 6-6	12
Rear Tires 20 x 10-8	10

Always see that the tire valve caps are in place and tightened securely to prevent loss of air and protect the valve core and stem.

Do not overload the tractor tires by mounting equipment on the tractor which exceeds the load capacity of the size of the tires on the tractor.

## MOUNTING TIRES ON THE RIM

After mounting a new or old tire on the rim, inflate it to 20 pounds pressure to seat the tire bead on the rim flange. Then deflate the tire to the correct operating pressure.



After the first 10 hours of operation, check and retorque the front wheel bolts to 35 ft-lbs. and rear wheel bolts to 23 ft-lbs. to make sure they have seated properly.

## OFF-SEASON STORAGE

If the machine is to be inoperative for a period longer than 30 days, the following procedures are recommended:



### WARNING

Never store engine with fuel in tank indoors or in poorly ventilated enclosures, where fuel fumes may reach an open flame, spark or pilot light as on a furnace, water heater, clothes dryer, etc.

1. Remove all gasoline from fuel tank to prevent gum deposits from forming on these parts and causing possible malfunction of engine.

Run engine until engine starts to falter, then use choke to continue engine operation until all fuel in tank and carburetor is exhausted. Remove fuel line at tank or carburetor and drain any remaining gasoline from system.



### WARNING

Drain fuel into approved container outdoors, away from open flame.

Fuel left in engine during warm weather deteriorates and will cause serious starting problems.

2. Remove spark plug and pour one (1) ounce of engine oil through spark plug hole into cylinder. Crank engine several times to distribute oil. Replace spark plug.
3. Clean the engine and the entire tractor thoroughly.
4. Lubricate all lubrication points and wipe the entire machine with an oiled rag in order to protect the surfaces.
5. Follow battery storage instructions on page 24.
6. Protect tires and seat from sunlight. Inflate tires at regular intervals.

## OPTIONAL EQUIPMENT AND ACCESSORIES

When you purchased your tractor, you probably had it completely equipped for your particular needs at the time. However, later you may wish to obtain optional equipment or accessories. These items and other allied equipment can be purchased from, and installed by, your authorized dealer.

The tractor is used for so many different types of work, and because it is called on to operate under so many different conditions, a variety of equipment is available to adapt it to the requirements of the user. Refer to equipment catalog.

# MOWING

## STARTING THE MOWER



In heavy grass, full throttle may be needed when starting the mowing deck.

With the engine running at idle speed, start the power take-off clutch (see page 15, Figure 15). Starting the mower with the engine in idle will reduce wear on the drive belt. Increase engine speed to full throttle.

## STOPPING THE MOWER

Move the power take-off (PTO) switch to "OFF" and reduce engine speed.

## MOWING



### WARNING

To avoid possible injury, do not allow anyone in the area opposite the discharge chute while mowing. Although the area has been supposedly cleared of foreign objects, small objects may be discharged by the mower.



### WARNING

Never direct discharge of material toward bystanders or allow anyone near the machine while in operation.

For best results it is recommended that the first two laps should be cut with the discharge thrown towards the center. After the first two laps, reverse the direction to throw the discharge to the outside for the balance of cutting. This will give a better appearance to the lawn.

Do not cut the grass too short, as the mower will tend to scalp the grass. Short grass invites weed growth and yellows quickly in dry weather.

Mowing should be done with the engine at full throttle. Do not mow at high ground speed.

During certain times of the year and under some conditions, the mower may leave streaks of uncut material.

Streaking may occur when attempting to mow heavy weeds and tall grass. Under these conditions it may be necessary to go back over the cut area a second time to get a clean cut.

The following practices will help eliminate streaking:

1. Mow the area more often so the grass doesn't get too tall and heavy.
2. Operate the tractor at full throttle and lower forward speeds.
3. Keep the blades sharp and replace blades when worn.
4. Follow the mowing procedure shown in Figure 29.

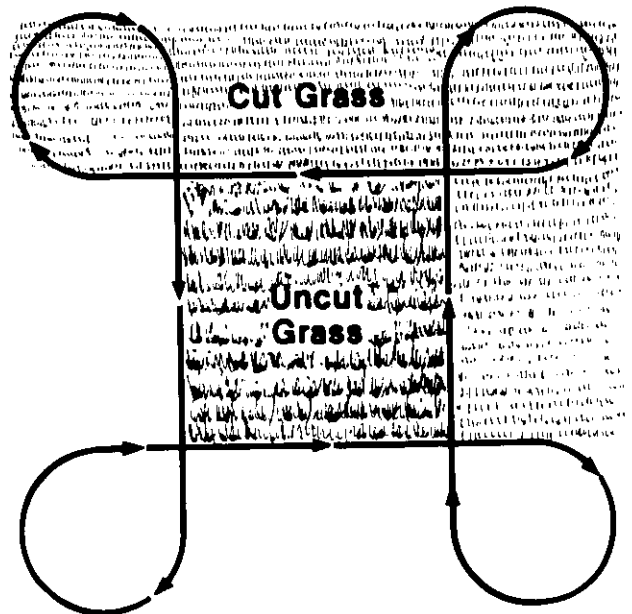

Figure 29

## MAINTENANCE CHART

Operation to be performed	Before each use	10 hours or once a month	25 hours three times a season	50 hours	100 hours or yearly	Before storage
Clean grille (front & backside) & engine inlet air screen		More often under dirty conditions X				
Check engine oil level	X					
Fill fuel tank	X					
Cylinder head cleaning	Leaded fuel — 250 hours Unleaded fuel — 500 hours					
Change engine oil	After first 5 hours		Without filter kit X	With filter kit installed X		
Check battery electrolyte level		X				
Grease front axle pivot bolt		X		X		
Lubricate steering knuckles (2) and steering arm		X				
Retorque rear and front wheel bolts		After first 10 hours X			X	
Lubricate brake shaft				X		
Change engine oil filter				With filter kit installed X		
Clean cooling fins & external surfaces				X		
Service air cleaner					More often under dirty conditions	
Check spark plugs					X	X
Lubricate speed control linkage cam plates (1420 Tractor)					X	
Check and regrease front wheel bearings					X	X
Drain fuel						X
Pivot bar adjustment bolt				X		
Movable idler bracket				X		
Steering gear				X		

# TROUBLE SHOOTING

## Possible Cause

## Possible Remedy

### HARD TO START

No gasoline in fuel tank or carburetor .....	Fill the tank with gasoline; open the fuel shut-off valve. Check the fuel line and carburetor.
Fuel line or carburetor clogged .....	Clean the fuel line and carburetor with commercial carburetor cleaner.
Water in gasoline .....	Drain the fuel tank and carburetor. Use new fuel and dry the spark plug.
Choked improperly. Flooded engine .....	Follow the starting instructions.
Defective ignition or loose wiring .....	Check the wiring, spark plug, or fuse.
Defective battery .....	Check and service. Refer to "BATTERY."
Spark plug dirty or improper gap .....	Clean, adjust the gap to .025-inch or replace the plug.

### ENGINE OPERATES IRREGULARLY OR KNOCKS

Engine incorrectly timed .....	*
Spark plug dirty; wrong gap or wrong type .....	Clean, reset the gap, or replace.
Poor or weak spark .....	Check the spark plug and wiring.*
Carburetor setting incorrect .....	Adjust. Refer to "ADJUSTMENTS"*
Poor grade fuel or water in fuel .....	Drain and use a good grade of clean fuel.
Engine overheating .....	Refer to "MAINTENANCE."
Engine valves at fault .....	*
Engine smokes .....	Adjust the carburetor.*
Oil level will rise due to gasoline in crankcase .....	Refer to "OPERATING IN COLD WEATHER."
Air filter will become oil and fuel soaked .....	Refer to "OPERATING IN COLD WEATHER."
Engine leaks oil .....	Refer to "OPERATING IN COLD WEATHER."
Misfiring .....	Refer to "OPERATING IN COLD WEATHER."
Other engine problems .....	*
Excessive oil in air cleaner .....	Be sure that oil dipstick is fully seated and all excess oil is squeezed out of pre-cleaner foam element.

### LACK OF POWER

Air cleaner clogged .....	Service the air cleaner element. Refer to "MAINTENANCE."
Engine overload .....	Reduce the load.
Engine overheated .....	Make sure air intake screen, shrouding, engine fins, and grille are free of accumulated dirt and trash. Refer to "MAINTENANCE."
Poor fuel, too rich, or too lean a mixture .....	Refer to "ADJUSTMENTS."
Fuel tank air vent clogged .....	Open the vent in the cap.
Air leakage between carburetor and engine .....	Remove air cleaner. Tighten the carburetor and manifold mounting nuts. Replace as indicated in "MAINTENANCE."

\*See your authorized dealer.

# TROUBLE SHOOTING

## Possible Cause

## Possible Remedy

### LACK OF POWER (Cont)

Incorrect timing or faulty ignition .....	*
Brake drags .....	Adjust the brake. Refer to "ADJUSTMENTS."
Belt slipping (1415 Tractor Only) .....	Adjust the free travel of the pedal. Refer to "ADJUSTMENTS."*

### ENGINE OVERHEATING

Insufficient cool air, dirty air intake screen, shroud, cooling fins, or dirty grille .....	Keep the air intake area and cooling fins clean; refer to "MAINTENANCE."
Lean carburetor adjustment .....	Readjust. Refer to "ADJUSTMENTS."
Oil level incorrect .....	Engine oil level must not be over the "FULL" mark or below the "LOW" mark. Refer to "MAINTENANCE."

\*See your authorized dealer.

## LUBRICATION TABLE

Point of Lubrication	Check at Hours	Change at Hours	Capacity	Anticipated Air Temperature		
				Above +32°F	+32° to 0°F	Below 0°F
Engine crankcase (W/O filter)	Check before each use	25	3-1/2 pints	<i>Cub Cadet</i> Low Ash Engine Oil	<i>Cub Cadet</i> Low Ash Oil S.A.E. 10W-40 or 10W-30	<i>Cub Cadet</i> Low Ash Engine Oil S.A.E. 5W-20 or 5W-30
(W/filter)		50	4 pints	S.A.E.		
Steering knuckles & front axle pivot bolt	10		Use 251H EP grease or equivalent No.2 multi-purpose lithium grease and apply two or three strokes or sufficient grease to flush out old grease and dirt.			
Front wheel bearings	100 or yearly		Remove front wheels and pack bearings with 251H EP grease or equivalent No. 2 multi-purpose lithium grease and reinstall wheels.			
Steering gear	50		Turn the steering wheel fully to the right and brush on 251H EP grease or equivalent No. 2 multi-purpose lithium grease to the steering gear. Turn the steering wheel in both directions to disperse the grease.			

## LUBRICATION GUIDE

The life of any machine depends upon the care it is given. Proper lubrication is a very important part of that care.

Be certain that all lubrication fittings are assembled in place, using the lubrication illustrations as a guide.

Always lubricate the tractor thoroughly before taking it to the field. Use a pressure lubricating gun.

Be sure all fittings are free from dirt and paint so the lubricant is certain to enter the bearing.

Always force the lubricant through the full length of each bearing until it emerges at the end, carrying with it the worn lubricant and any dirt that may have entered the bearing.

Miscellaneous work parts not provided with lubrication fittings should be oiled periodically with a good grade of lubricating oil.

Lubricant is cheap. Use plenty of it. Worn parts can be expensive to replace.

Keep your supply of lubricating oil and grease stored in clean containers, and covered to protect from dust and dirt.

Keep the lubricating gun nozzle clean and wipe dirt from grease fittings before lubricating.

The symbols in the illustration indicate the method of application and the hourly intervals to apply the lubricant.



Use a pressure lubricating gun and apply 251H EP grease (or equivalent No. 2 multi-purpose lithium grease) sufficient to flush out the old grease and dirt. Lubricate at hourly intervals indicated on symbols.



Dipstick, use to check engine oil before each use.

# LUBRICATION GUIDE

## —BEFORE EACH USE

1. Engine filler cap and dipstick

Check the oil (with the engine stopped) and add sufficient new oil to bring it to the "FULL" mark on the dipstick. Do not overfill. Do not operate the engine if the oil level is below the "LOW" mark on the dipstick.

## —AFTER EVERY 10 HOURS OF OPERATION

2. Steering knuckles (2)  
(Both sides)

Use 251H EP grease or equivalent No. 2 multi-purpose lithium grease and apply sufficient grease to flush out old grease and dirt.

3. Front axle pivot bolt  
(Right side)

Use 251H EP grease or equivalent No. 2 multi-purpose lithium grease and apply sufficient grease to flush out old grease and dirt.

**NOTE:** It may be necessary to rotate the front axle to reach the grease fitting.

## —AFTER EVERY 25 HOURS OF OPERATION

4. Engine oil drain plug

While the engine oil is warm, remove the (without oil filter drain plug and drain all of the oil from the kit installed) crankcase. Replace the drain plug. Refer to "MAINTENANCE" "FILLING THE CRANKCASE" for proper oil filling procedure. Refer to "LUBRICATION TABLE" for the proper quantity and viscosity to use.

## —AFTER EVERY 50 HOURS OF OPERATION

5. Engine oil drain plug  
(With oil filter kit installed)

While the engine oil is warm, remove the drain plug and drain all of the oil from the crankcase. Remove oil filter and replace with a new one. Replace the drain plug. Refer to "MAINTENANCE" "FILLING THE CRANKCASE" for proper oil filling procedure. Refer to "LUBRICATION TABLE" for the proper quantity and viscosity to use.

6. Steering gear

Turn the steering wheel fully to the right and brush on 251H EP grease or equivalent No. 2 multi-purpose lithium grease to the steering gear. Turn the steering wheel in both directions to disperse the grease.

## —EVERY 100 HOURS OF OPERATION

7. Movable idler bracket

Use 251H EP grease or equivalent No. 2 multi-purpose lithium grease and apply sufficient grease to flush out old grease and dirt.

### Speed Control Linkage

8. Cam plates  
(1420 Tractor)

Once a year, apply a small amount of 251H EP grease or equivalent No. 2 multi-purpose lithium grease in the slots.

### Miscellaneous

Brake pedal shaft

Lubricate the brake pedal shaft and linkage with eight or ten drops of engine oil.

Deck spindles

Refer to deck manual.

**LUBRICATION GUIDE  
MODEL 1415**

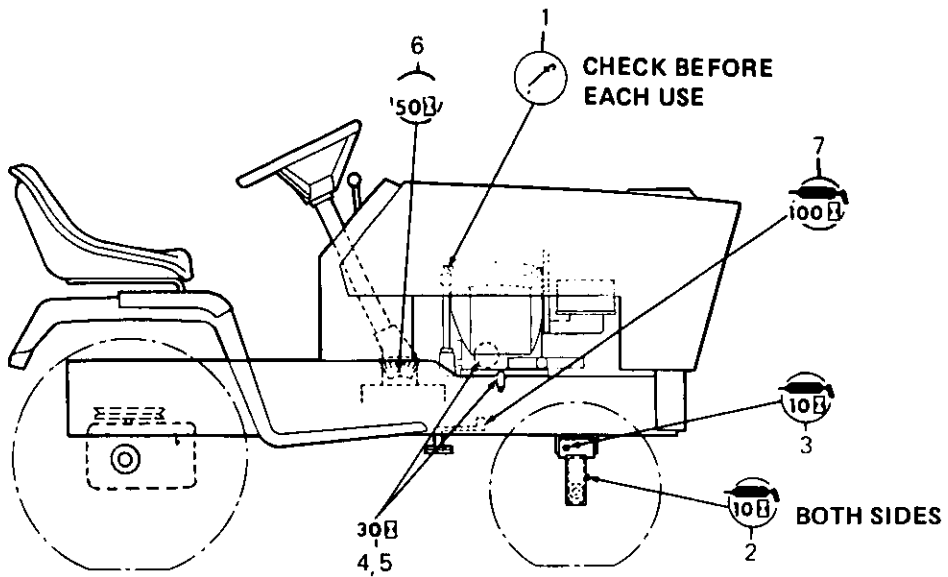

**INITIAL OIL CHANGE AT 5 HOURS,  
AND EVERY 25 HOURS THEREAFTER  
(WITH FILTER EVERY 50 HOURS THEREAFTER)**

**LUBRICATION GUIDE  
MODEL 1420**

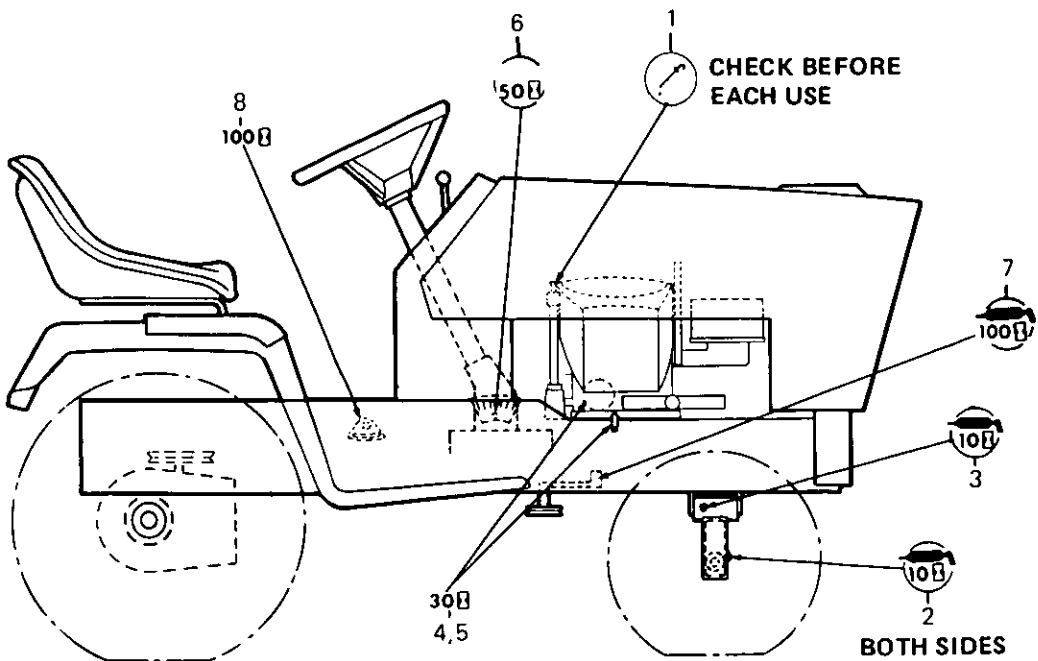

**INITIAL OIL CHANGE AT 5 HOURS,  
AND EVERY 25 HOURS THEREAFTER  
(WITH FILTER EVERY 50 HOURS THEREAFTER)**



# SPECIFICATIONS

	1415	1420
<b>CAPACITIES</b>		
Fuel Tank .....	3 gals.	
Crankcase .....	4 pints with filter 3-1/2 pints without filter	
<b>TRANSMISSION GEARS</b>	5 forward speeds and 1 reverse	
Speed: Forward .....	0 to 5.5 mph	
Reverse .....	0 to 2.35 mph	
<b>HYDROSTATIC DRIVE</b>		
Speed: Forward .....		0 to 5.5 mph
Reverse .....		0 to 3.0 mph
<b>ENGINE</b>		
Make and model .....	Kohler	
(electric starting) .....	14 HP	
Cylinders .....	2	
Bore .....	3.75 in.	
Stroke .....	3.25 in.	
Displacement (cubic inches) .....	35.90	
Compression ratio .....	5.8 - 1	
Engine speed .....	(governed)	
Low speed .....	1800 RPM	
High idle speed (no load) .....	3400 RPM ±75	
Valve clearance (engine cold) .....	.008-.010 in. (intake) .017-.020 in. (exh.)	
Ignition .....	Battery	
Spark plug .....	<i>Cub Cadet No. 759-3334</i>	
Spark plug gap .....	.025 in. gap	
<b>ELECTRICAL SYSTEM</b>		
System voltage .....	12 volt neg. ground	
Battery .....	1 HPRLU	
Alternator .....	16 amp	
Fuse (cartridge type) .....	20 amp slow blow	
Headlights (bulb) .....	GE 12 volt 1156	
<b>BRAKES</b> .....	Single disc, external	
<b>CLUTCH</b> .....	V-belt	
<b>TIRE SIZES</b>		
Front .....	15 x 6-8	
Rear .....	20 x 10-8	
<b>GENERAL</b>		
Wheelbase .....	45.0 in.	
Length, over-all .....	68.50 in.	
Turning radius .....	29.00 in.	
Available mower sizes .....	38 or 46 inches	
Adjustable cutting height (approx) .....	1-1/2 to 4 inches	
Mower drive .....	V-belt with electric clutch	

Specifications are subject to change without notice.



USE THIS SHEET AS A GUIDE TO DETERMINE SLOPES WHERE YOU MAY NOT OPERATE SAFELY.

# SLOPE GAUGE

(Keep this sheet in a safe place for future reference.)

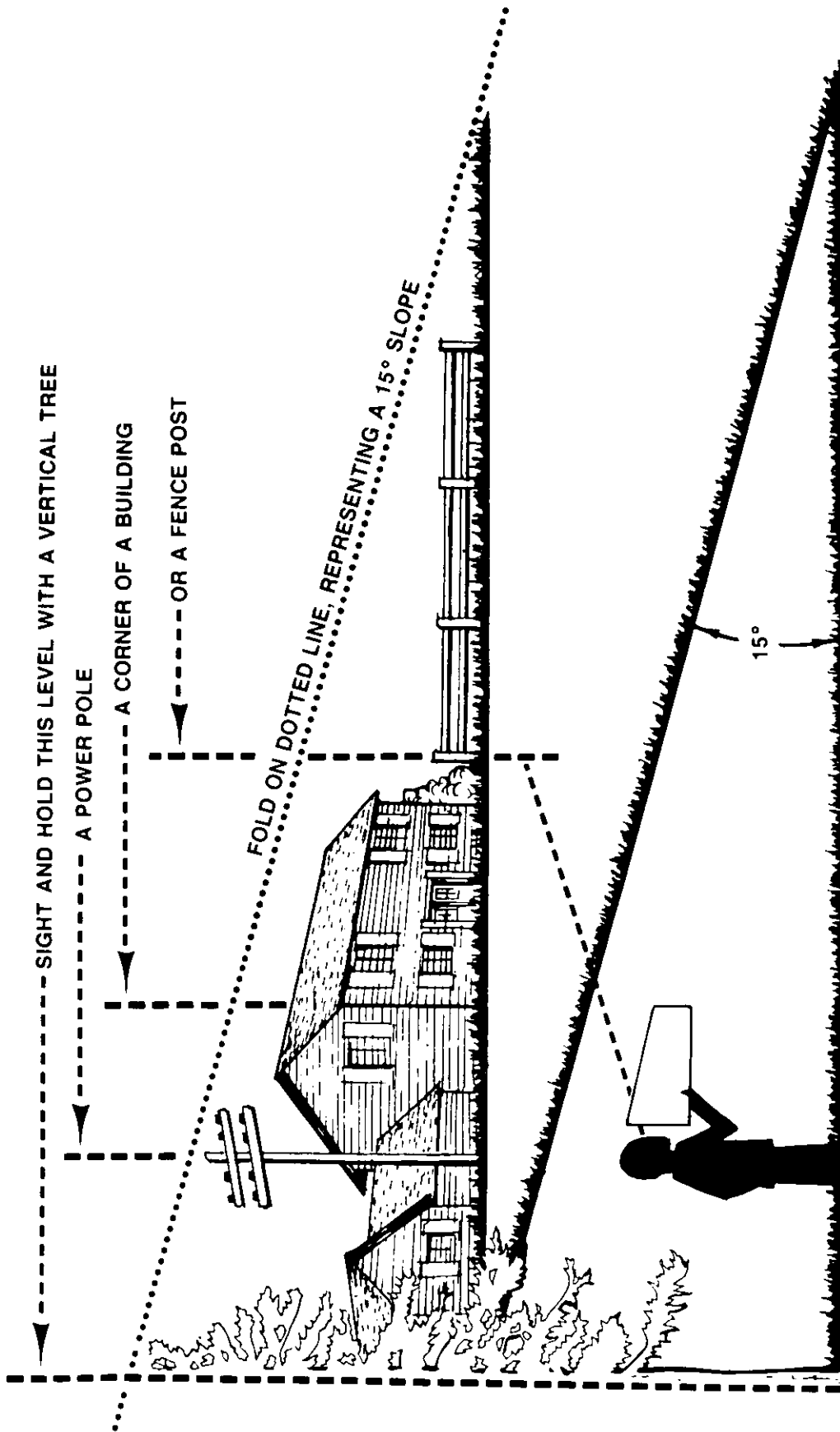

Do not mow on inclines with a slope in excess of 15 degrees (a rise of approximately 2½ feet every 10 feet). A riding mower could overturn and cause serious injury. If operating a walk-behind mower on such a slope, it is extremely difficult to maintain your footing and you could slip, resulting in serious injury.

Operate RIDING mowers up and down slopes, never across the face of slopes.

Operate WALK-BEHIND mowers across the face of slopes, never up and down slopes.

