

*Cub Cadet*<sup>®</sup>

**Power Equipment**

# Owner's Manual

---

## LAWN TRACTORS

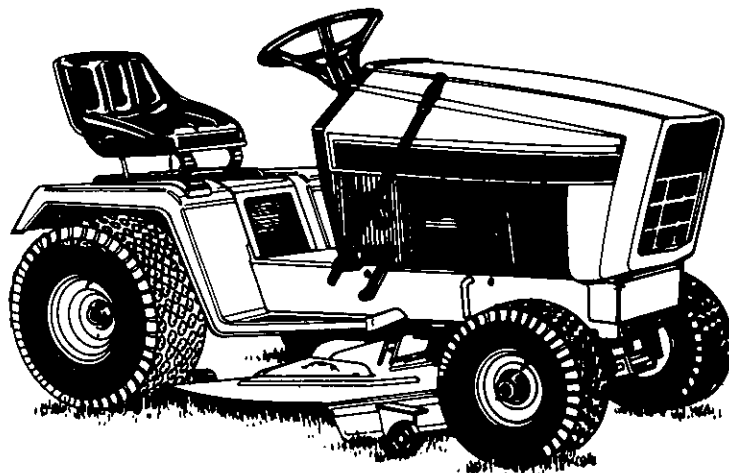

### Model Numbers

1215

1220

### Important:

**Read Safety Rules and Instructions Carefully**

Thank you for purchasing an American-built product.

**CUB CADET CORPORATION • P.O. BOX 36930 • CLEVELAND, OHIO 44136**

PRINTED IN U.S.A.

FORM NO. 772-3863  
R870205

## Cub Cadet Corporation's Promise To You

We promise you, the first user purchaser, that we will replace or repair any part or parts of your new outdoor power product which is defective in material or workmanship without charge for either parts or labor during the first year following delivery to you.

We also promise you, the first user purchaser, a second year warranty on the engine and drive train of your new *Cub Cadet* Tractor, Lawn Tractor or Riding Tractor.

### What the second year covers

(A) It will cover the engine internal parts contained within the engine shielding except for points, condensers, spark plugs, air filters, oil filters, and routine maintenance parts.

(B) It will cover the tractor drive train including drive shafts, drive shaft clutch, all parts enclosed by transmission housing, and axle housing, axle shafts, final drives, spindle pulleys, spindle bearings, and electric PTO clutch.

**Home Maintenance Products:** We promise you, the first user purchaser, a 1 year warranty on all Home Maintenance Products. This will cover Push Mowers, Self Propelled Mowers, Utility Trailers, Walk Behind Tillers, Chore Performers and Snow Throwers.

The Tecumseh engine, used on Walk Behind Snow Throwers, will carry a 2 year warranty on the engine only.

### Cub Cadet Attachments:

We promise you, the first user purchaser, that we will replace or repair any part or parts which are defective in material or workmanship without charge for parts or labor during the first year following delivery to you. This will cover all *Cub Cadet* attachments. This does not include Approved Allied Equipment which is sold and warranted directly by the manufacturer.

### Obtaining Warranty Service Through Cub Cadet Dealers

Warranty repairs will be made by your selling *Cub Cadet* dealer or any *Cub Cadet* dealer authorized to sell the type of equipment involved during the normal working hours of the dealer service department. You, the purchaser, are responsible for transportation of the equipment to the dealership for warranty service or for any service call expense, along with any overtime labor you request.

### Replacement Parts Warranty

*Cub Cadet* parts which are furnished and installed under this warranty are themselves within the coverage of this warranty for the duration of the original warranty period or for ninety days after installation, whichever period shall expire last.

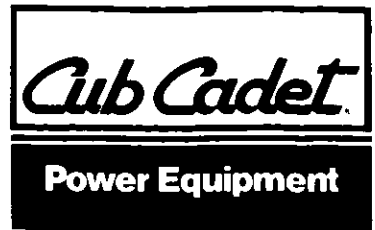

### What is not Covered

Tires and tubes are not covered by this warranty, but are warranted by their manufacturer. Regular maintenance replacement items such as spark plugs, ignition points, condensers, belts, cutting parts, filters and lubricants, and maintenance adjustments such as fuel system cleaning, engine tune-up, brake and/or clutch inspection or adjustment, when such replacement or adjustments are made as part of normal maintenance service are excluded from coverage. Any non-*Cub Cadet* product which you may have installed in or upon the product is also excluded.

No person is authorized to give any other warranty or to assume any other liabilities on the Company's behalf unless made or assumed in writing by the Company, and no person is authorized to give any warranties or to assume any liabilities on the seller's behalf unless made or assumed in writing by the seller.

### Limitations On Our Responsibility

Please carefully note that this is a two-way agreement. We promise to make free repairs or replacements as stated, but you agree, that except for our obligation to make good on this promise, we shall not be responsible for any expenses or inconvenience which you might incur or experience with respect to our product, nor shall we be liable for defects, damage, or failures caused by unauthorized alterations, unreasonable use, accident or abuse, including failure to provide reasonable and necessary maintenance, after our product has been delivered to you. Some states do not allow the exclusion or limitation of incidental or consequential damages, so the above limitation or exclusion may not apply to you. This warranty gives you specific legal rights, and you may also have other rights which vary from state to state.

### Personal Use

The foregoing paragraphs constitute *Cub Cadet* Corporation's entire warranty with respect to any product purchased and used for personal, family, or household purposes as distinguished from commercial usage.

### Commercial Use:

All *Cub Cadet* products will be warranted against defective parts or workmanship. This is for *Cub Cadet* Tractor, Attachments and Home Maintenance products and for one year only.

THIS WARRANTY IS IN LIEU OF ALL OTHER WARRANTIES, EXPRESSED OR IMPLIED. WARRANTIES OF MERCHANTABILITY AND FITNESS FOR PARTICULAR PURPOSE ARE EXCLUDED, AS ARE ALL OTHER REPRESENTATION TO THE USER-PURCHASER, AND ALL OTHER OBLIGATIONS OR LIABILITIES, INCLUDING LIABILITY FOR INCIDENTAL AND CONSEQUENTIAL DAMAGES, ON THE PART OF THE COMPANY OR THE SELLER.

# CONTENTS

Warranty . . . . .	2	Off-Season Storage . . . . .	23
Safe Operations . . . . .	3	Optional Equipment and Accessories . . . . .	23
To The Owner . . . . .	6	Maintenance Chart . . . . .	30
Serial Number Location . . . . .	6	Trouble Shooting . . . . .	31
Controls . . . . .	7	Lubrication Table . . . . .	32
Operation . . . . .	10	Lubrication Guide . . . . .	33
Adjustments . . . . .	13	Specifications . . . . .	33
Maintenance . . . . .	19		



Instructions given with this symbol are for personal safety. Be sure to follow them.



## WARNING

This unit is equipped with an internal combustion engine and should not be used on or near any unimproved forest-covered, brush-covered or grass-covered land unless the engine's exhaust system is equipped with a spark arrester meeting applicable local or state laws (if any). If a spark arrester is used, it should be maintained in effective working order by the operator.

In the State of California the above is required by law (Section 4442 of the California Public Resources Code). Other states may have similar laws. Federal laws apply on federal lands. A spark arrester muffler is available at your nearest engine authorized service center.



## WARNING

To reduce the potential for any injury, comply with the following safety instructions. Failure to comply with the instructions may result in personal injury.

## SAFE OPERATION PRACTICES FOR RIDING VEHICLES

1. Read the owner's manual carefully in its entirety before attempting to assemble or operate this unit. Keep this manual in a safe place for future and regular reference and for ordering replacement parts.
2. This unit is a precision piece of power equipment not a plaything. Therefore, exercise extreme caution at all times.
3. Know the controls and how to stop quickly - READ THE OWNER'S MANUAL.
4. Do not allow children to operate vehicle. Do not allow adults to operate it without proper instruction. Only persons well acquainted with these rules of safe operation should be allowed to use your mower.
5. No one should operate this unit while intoxicated or while taking medication which impairs the senses or reactions.
6. Wear sturdy, rough-soled work shoes and close-fitting slacks and shirts to avoid entanglement in the moving parts. Never operate a unit in bare feet, sandals, or sneakers.
7. To prevent injury, do not carry passengers or give rides. Keep children, pets and bystanders out of the area while mowing. Only the operator should ride on the unit and he/she should ride only in the seat.
8. Check overhead clearance carefully before driving under power lines, guy wires, bridges or low hanging tree branches; before entering or leaving buildings, or in any other situation where the operator may be struck or pulled from the unit. Such negligence could result in serious injury.
9. To maintain control of the unit and reduce the possibility of upset or collision, operate the tractor smoothly. Avoid erratic operation and excessive speed.
10. Keep the area of operation clear of all persons, particularly small children and pets. Stop engine when they are in the vicinity of your mower. Although the area of operation should be completely cleared of

foreign objects, a small object may have been overlooked and could be accidentally thrown by the mower in any direction and cause injury.

11. Clear work area of objects which might be picked up and thrown in any direction by the mower and cause injury.
12. Stop the blade(s) when crossing gravel drives, walks or roads.
13. Disengage all attachment clutches and shift into neutral before attempting to start engine.
14. Disengage power to attachment(s) and stop engine before leaving operating position.
15. Do not put hands or feet near or under rotating parts. Stay clear of the discharge opening at all times as the rotating blade(s) can cause injury.
16. Disengage power to attachment(s) and stop engine before making any repairs or adjustments. Disconnect the spark plug wire(s) and keep the wire(s) away from the plug to prevent accidental starting.
17. Before attempting to unclog the mower or discharge chute, stop the engine. The mower blade(s) may continue to rotate for a few seconds after the engine is shut off. Therefore, be sure the blade(s) have stopped completely. Disconnect the spark plug wire(s) and keep the wire(s) away from the plug to prevent accidental starting.
18. Disengage power to attachment(s) when transporting or not in use.
19. Take all possible precautions when leaving vehicle unattended such as disengaging power-take-off, lowering attachments, shifting into neutral, setting parking brake, stopping engine and removing key.
20. Do not stop or start suddenly when going uphill or downhill. Mow up and down face of steep slopes; never across the face. Use extreme caution if it is necessary to drive the tractor up an incline or back the tractor down an incline because the front of the tractor could lift and rapidly flip over backward which could cause serious injury.
21. Reduce speed on slopes and in sharp turns to prevent tipping or loss of control. Always keep the tractor in gear when going down steep hills to take advantage of engine braking action.
22. Stay alert for holes in terrain and other hidden hazards.
23. Use care when pulling loads or using heavy equipment.
  - A. Use only approved drawbar hitch points.
  - B. Limit loads to those you can safely control.
  - C. Do not turn sharply. Use care when backing.
  - D. Use counterweight(s) or wheel weights when suggested in owner's manual.
24. Watch out for traffic when crossing or near roadways.
25. When using any attachments, never direct discharge of material toward bystanders. Do not allow anyone near vehicle while in operation.
26. Handle fuel with care. It is highly flammable.
  - A. Use approved fuel container.
  - B. Never remove cap or add fuel to a running or hot engine or fill fuel tank indoors. Wipe up spilled fuel.
  - C. Open doors if engine is run in garage. Exhaust fumes are dangerous. Do not run engine indoors.
27. Keep the vehicle and attachments in good operating condition, and keep safety devices in place. Use guards as instructed in operator's manual.
28. Keep all nuts, bolts, and screws tight to be sure the equipment is in safe working condition.
29. Never store the equipment with fuel in the tank inside a building where fumes may reach an open flame or spark. Allow engine to cool before storing in any enclosure.
30. To reduce fire hazard, keep engine free of grass, leaves or excessive grease.
31. The vehicle and attachment should be stopped and inspected for damage after striking a foreign object. The damage should be repaired before restarting and operating the equipment.
32. Do not change the engine governor settings or overspeed the engine.
33. When using the vehicle with mower, proceed as follows:
  - A. Mow only in daylight or in good artificial light.
  - B. Never make a cutting height adjustment while engine is running if operator must dismount to do so.
  - C. Shut the engine off and wait until the blade comes to a complete stop before removing the grass catcher.
  - D. Check blade mounting bolts for proper tightness at frequent intervals.
34. Check grass catcher bags frequently for wear or deterioration. For safety protection, replace only with new bag meeting original equipment specifications.
35. Look behind to make sure the area is clear before placing the transmission in reverse and continue looking behind while backing up. Disengage blades before shifting into reverse and backing up.
36. This unit should not be driven up a ramp onto a trailer or truck under power, because the unit could tip over, causing serious personal injury. The unit must be pushed manually to load properly.

## PRODUCT GRAPHICS

Keep safety product graphics (decals) clean.  
Replace any safety graphic that is damaged,

destroyed, missing, painted over or can no longer be read. Replacement safety graphics are available through your dealer.

# CAUTION

**RECEIVE INSTRUCTION** — Read operator's manual. Learn to operate this machine SAFELY. Don't risk INJURY or DEATH.

1. Before starting engine or operation: Be familiar with controls. Be in operator's position with transmission in neutral, PTO turned off, and brake depressed.
2. Keep shields in place. Keep away from moving parts.
3. NO RIDERS! Keep all people and pets a safe distance away.
4. Don't point mower discharge at people.
5. Avoid slopes. Tractors can be rolled over.
6. Before leaving operator's position:  
Shut off PTO. Place transmission in neutral. Set parking brake. Shut off engine. Remove ignition key. Wait for all movement to stop before servicing or cleaning.
7. Do not fill gasoline tank when engine is running.  
Tighten cap securely.

192-292 C 3236

GENERAL SAFETY INSTRUCTIONS CAUTION LOCATED ON THE FRAME COVER.

# CAUTION

Electrical system is 12 volt negative ground. When using booster with jumper cables, precautions must be taken to prevent personal injury or damage to electrical parts.

1. Attach one end of jumper cable to positive terminal of booster battery and other end to positive terminal of vehicle battery.
2. Attach one end of second cable to negative terminal of booster battery and other end to vehicle frame away from battery.
3. To remove cables, reverse above sequence exactly to avoid sparks. See operator's manual for additional information.

**CAUTION—BOOSTER BATTERY INSTRUCTIONS**  
LOCATED UNDER THE HOOD.

# TO THE OWNER

Assembled in this manual are operation, lubrication, and maintenance instructions for the *Cub Cadet* 1215 and 1220 Tractors. The material has been prepared in detail to help you better understand the correct care and efficient operation of your tractor. Before you operate the tractor, study this manual carefully. Additional copies may be ordered from your dealer at a nominal price.

Your local authorized dealer is interested in the performance you receive from your tractor. He has factory-trained servicemen, informed in the latest method of servicing tractors, modern tools, and original-equipment service parts which assure proper fit and good performance.

The *Cub Cadet* 1220 Tractor has a hydrostatic drive unit and will require minimum service if recommended operation and maintenance procedures are followed.

To obtain top performance and assure economical operation the tractor should be inspected, depending on its use, periodically, or at least once a year, by your authorized dealer.

When in need of parts, always specify the model, chassis, and engine serial numbers, including the prefix and suffix letters. Write these serial numbers in the space provided on this page.

Should you have difficulties with the unit consult your authorized dealer. **UNDER NO CIRCUMSTANCES SHOULD YOU ATTEMPT TO SERVICE THESE UNITS YOURSELF.** Only your dealer is authorized to repair or replace units on this drive under the terms of the warranty. Should you desire additional information not found in this manual, contact your authorized *Cub Cadet* dealer.

## SERIAL NUMBER LOCATION



LEFT and RIGHT indicate the left and right sides of the tractor when facing forward in the driver's seat. Reference to FRONT indicates grille end of the tractor; to REAR the drawbar end.

Chassis serial number plate is on the left hand side of frame. (See Figure 1.)

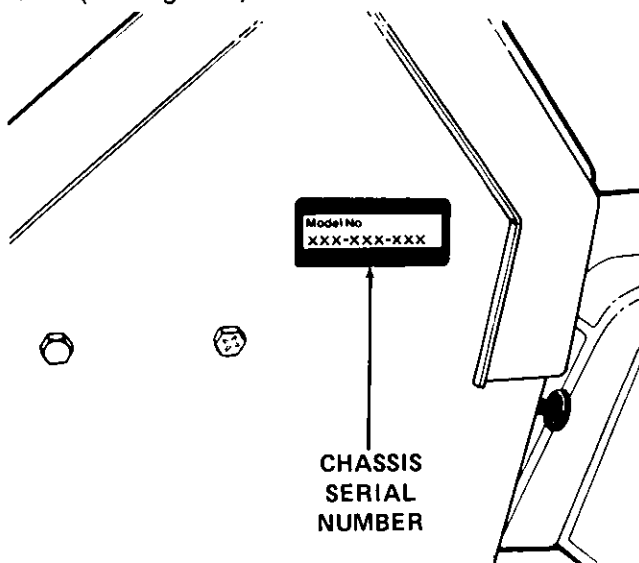

Figure 1.

Engine serial number plate is located on the engine shroud.

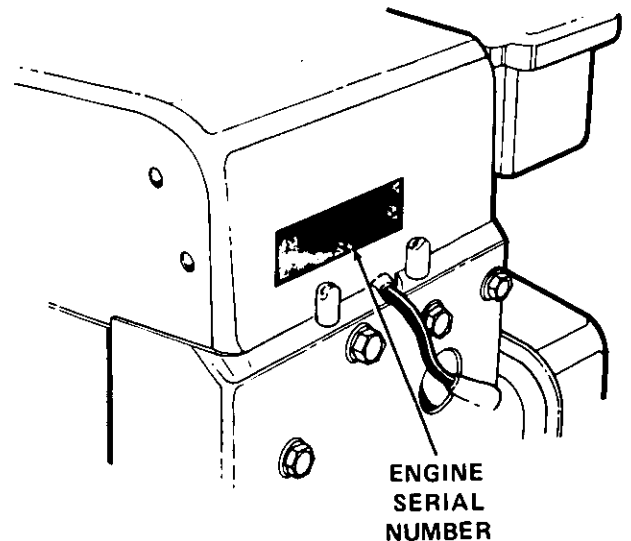

Figure 2.

MODEL \_\_\_\_\_

DELIVERY DATE \_\_\_\_\_

# CONTROLS

Your *Cub Cadet* Tractor has been safety engineered. Thoroughly acquaint yourself with all the instruments and controls before attempting to start or operate the tractor.

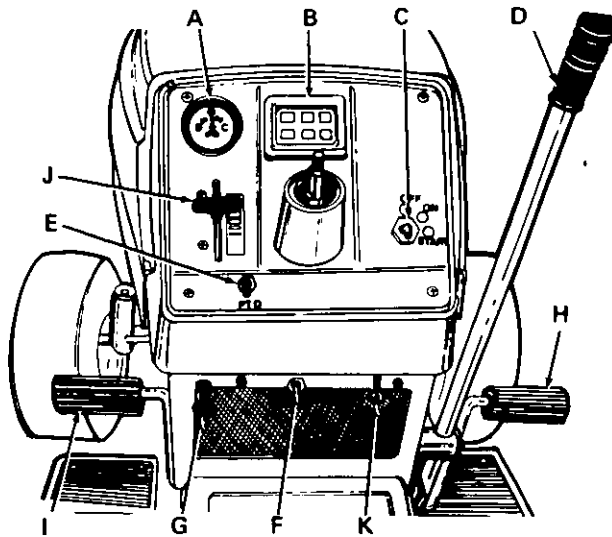

Figure 3.

## Model 1215 Gear Drive Tractor

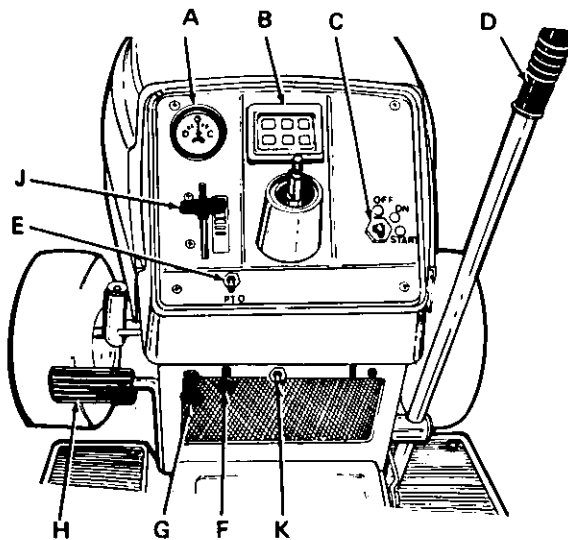

Figure 4.

## Model 1220 Hydrostatic Drive Tractor

- A. Charge Indicator
- B. Electronic Monitor
- C. Ignition Switch
- D. Lift Control Lever
- E. Power Take-Off (PTO)
- F. Parking Brake Lever
- G. Choke Control
- H. Brake Pedal
- I. Clutch Pedal
- J. Throttle Control Lever
- K. Light Switch

### A. CHARGE INDICATOR

This instrument indicates whether the alternator is charging or the battery is discharging. If it shows discharge continuously, investigate the cause to avoid completely discharging the battery and possible damage to the charging circuit. (See Figure 3 or 4.)

### B. ELECTRONIC MONITOR (See Figure 5)

**In Reverse Gear** — will be illuminated when tractor is in reverse. Light must be off to start tractor.

**Do Not Engage PTO** — will be illuminated if PTO switch is engaged while tractor is in reverse.

### NOTE

PTO will not be engaged with tractor in reverse — switch only will engage.

**PTO On** — light will be illuminated when PTO switch is engaged. Light must be off to start tractor.

**Place In Neutral** — light will be illuminated when starting tractor and gear shift is not in neutral. Light must be off to start tractor.

**Full Throttle Required** (two indicators) — top light will be illuminated when the PTO is engaged. Bottom light will be illuminated when the light switch is on.

### NOTE

The unit should be run at full throttle when using PTO operated equipment or when the headlights are on.

### C. IGNITION

### WARNING

Remove the key from the tractor when the tractor is not in use to prevent accidental starting and battery discharge.

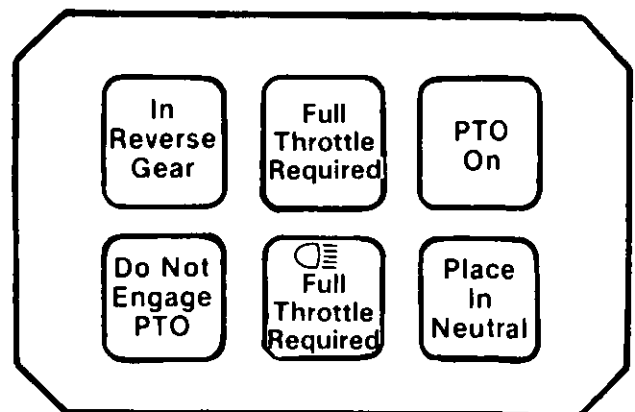

Figure 5.

The ignition switch is a three position switch. Turn key to "START" position. When the engine starts, release key. Key will retract to "ON" position. Turn key to "OFF" position to stop engine. (See Figure 3 or 4.)

#### D. LIFT CONTROL LEVER

This lever is used to raise and lower the cutting deck and other attachments. (See Figure 3 or 4.)

#### E. POWER TAKE-OFF (PTO)

The power take-off is an electric clutch operated by a toggle switch on the left side of the instrument panel. When PTO is engaged, throttle should be in fast position.

#### F. PARKING BRAKE LEVER (1215 Tractor)

The parking brake lever is located on the right side of the pedestal below the instrument panel. To operate, simultaneously depress clutch and brake pedals as you pull the parking brake lever up and out (towards the operator) to lock. To disengage parking brake, simultaneously depress clutch and brake pedal, lift parking brake lever up and release. The parking brake lever will retract. Always lock the parking brake when tractor is not in use. (See Figure 3.)

#### PARKING BRAKE LEVER (1220 Tractor)

The parking brake lever is located on the left side of the pedestal below the instrument panel. To operate, depress the brake pedal and hold it down while lifting the parking brake lever up and pulling out to lock. To disengage the parking brake, press down on the pedal and lift the lever up. The parking brake lever will retract. Always lock the brake when the tractor is parked on a grade. (See Figure 4.)

#### G. CHOKE CONTROL

The choke control is located on the left side of the pedestal below the instrument panel. The choke control is operated manually. Pull knob out to choke engine. Push knob in to open choke. (See Figure 3 or 4.)

#### H. BRAKE PEDAL (1215 Tractor)

The brake pedal is located on the right side of the tractor. (See Figure 3.)

#### BRAKE PEDAL (1220 Tractor)

The brake pedal is located on the left side of the tractor. When the pedal is depressed, the speed lever control is automatically moved to the neutral ("N") position. (See Figure 4.)

#### I. CLUTCH PEDAL (1215 Tractor)

The clutch pedal is located on the left side of the tractor. When the clutch pedal is depressed, the drive belt is disengaged from the engine pulley.

#### J. THROTTLE CONTROL LEVER

This lever controls the speed of the engine. When set in a given position, it will maintain a uniform engine speed. (See Figure 3 or 4.)

When using power take-off operated equipment, best performance is achieved with the throttle lever in the "FAST" position.



"Turtle" This symbol shows slow position.



"Rabbit" This symbol shows fast position.

#### K. LIGHT SWITCH

The lights are turned on and off by a toggle switch on the center of instrument panel. Flip switch up for "ON" or down for "OFF". When lights are on, throttle should be in "FAST" position.

#### L. INTERLOCKS (See Figures 6 and 7)

Interlock safety switches are located under the right hand fender, the PTO switch and seat.

The safety starting switches, activated by the gear shift lever (1215 Tractor) or the speed control lever (1220 Tractor) and the PTO switch, serve to prevent starting the engine accidentally. The gear shift lever (1215 Tractor) or the speed control lever (1220 Tractor) must be in neutral ("N") and the PTO switch in the "OFF" position before engine will start.

When using PTO operated equipment, the operator must remain seated at all times. If the operator should leave the tractor seat without turning off the PTO switch, the engine will automatically shut off. In addition, the PTO switch must be in the "OFF" position when shifting the tractor into reverse or the PTO will automatically disengage. To re-engage the PTO, shift into neutral ("N"), move PTO switch into the "OFF" position and then reactivate PTO while seated.

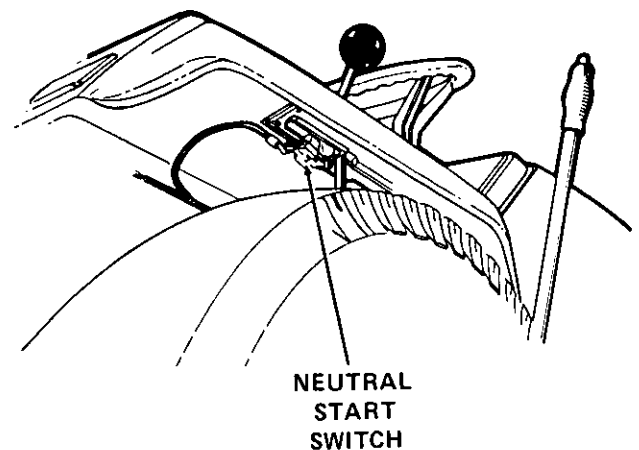

Figure 6.



REVERSE SWITCH AND  
PTO INDICATOR SWITCH

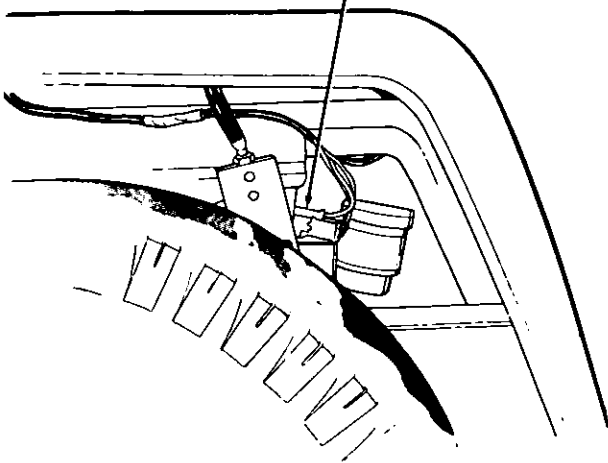

Figure 7.

**M. GEAR SHIFT LEVER (1215 Tractor)**



Clutch pedal must be fully depressed before shift lever can be moved.

The gear shift lever is located on the right rear tractor fender. This lever is used to select various gear ratios provided in the transmission. There are five forward speeds and one reverse speed. Refer to "SPECIFICATIONS". (See Figure 8.)

GEAR SHIFT LEVER

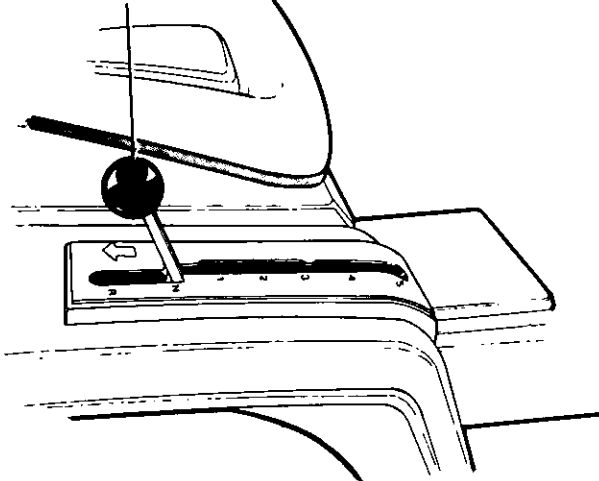

Figure 8.

**N. SPEED CONTROL LEVER (1220 Tractor)**

The speed control lever is located on the right rear tractor fender. Move the speed control lever forward for various forward tractor speeds or backward for various reverse tractor speeds. (See Figure 9.)

SPEED CONTROL LEVER

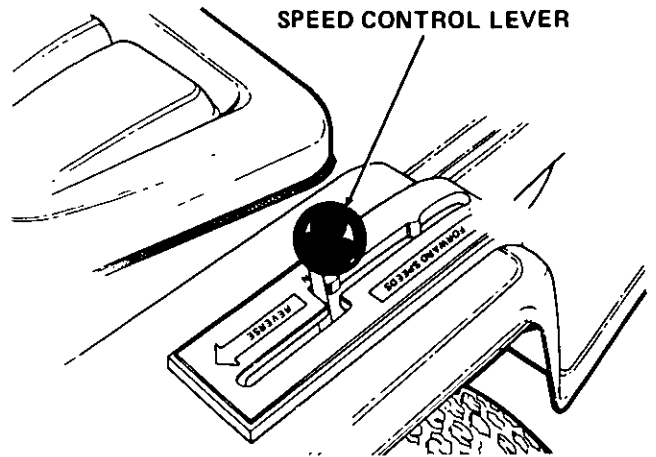

Figure 9.

**O. HYDROSTATIC DUMP VALVE LEVER (1220 Tractor)**

The hydrostatic dump valve lever is located on the frame cover.

The dump valve disconnects the transmission from the pump so the unit can be pushed without running.

1. To engage the dump valve (making the tractor free-wheeling), push the lever forward and hold in this position. (See Figure 10.)
2. To disengage the dump valve, release the lever. (See Figure 11.)

HYDROSTATIC  
DUMP VALVE  
LEVER

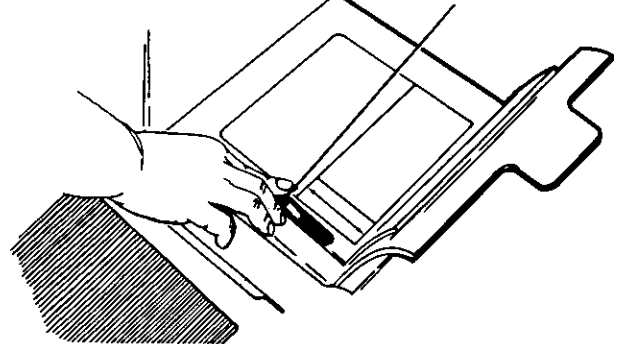

Figure 10.

HYDROSTATIC DUMP  
VALVE LEVER

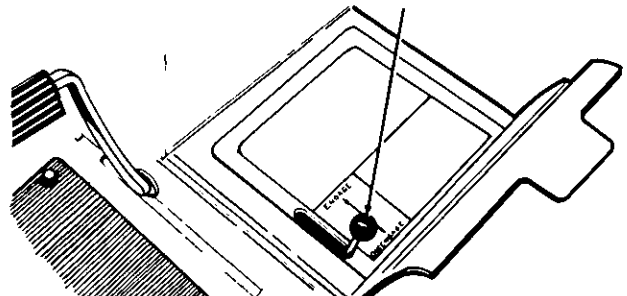

Figure 11.

## FUEL TANK AND GAUGE

The fuel tank and gauge are located under the operator's seat. (See Figure 12.)

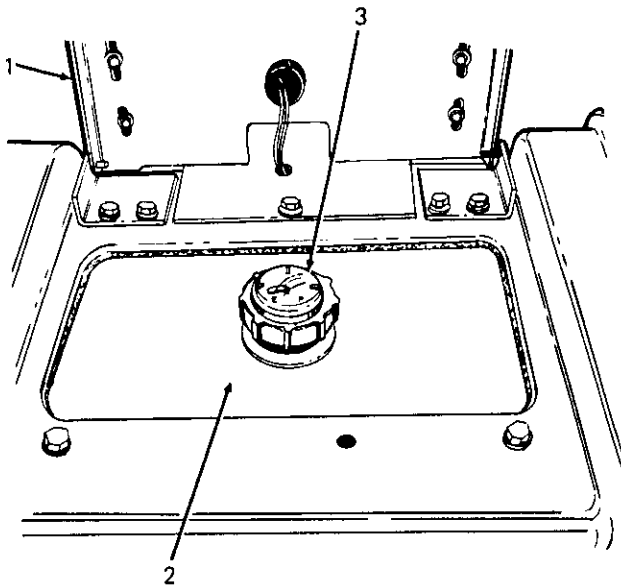

Figure 12.

1. Operator's Seat
2. Fuel Tank
3. Fuel Tank Gauge

## FUEL SHUT-OFF VALVE

The fuel shut-off valve is located under the tractor's rear fender. The fuel shut-off valve is used to shut off fuel flow to the engine to aid maintenance. (See Figure 13.)

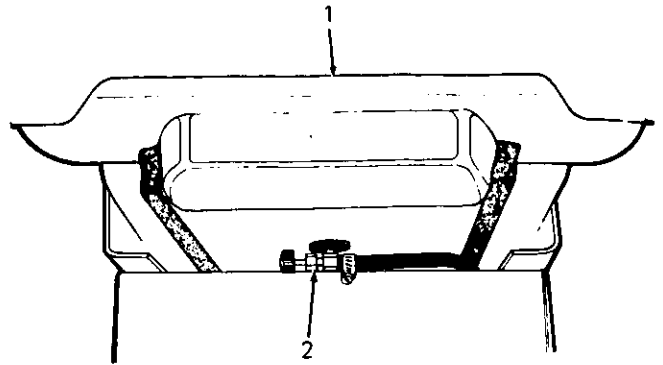

Figure 13.

1. Rear Fender
2. Fuel Shut-Off Valve

## LIFT CONTROL LEVER

The lift control lever is used to lift or lower equipment used with the tractor. The equipment can be set in five positions by depressing the button on the lever and releasing it when the desired position is reached. (See Figure 14.)

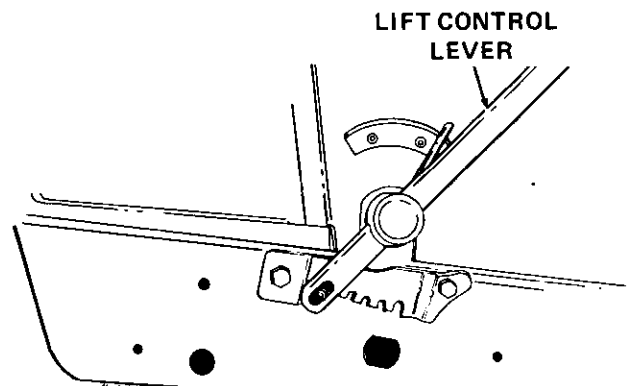

Figure 14.

# OPERATION

## PRE-OPERATION CHECKLIST

1. Check oil level. The oil fill and dipstick are located on the right rear side of the engine. (See Figure 15.)
2. Fill fuel tank with Regular or Unleaded gasoline.

## ENGINE OIL REQUIREMENTS

### Cub Cadet Low Ash Engine Oil

Ambient Temperature	Viscosity (Grade SF)
Above 40 degrees F	SAE 30
0 to 100 degrees F	SAE 10W30 or 10W40
Below 20 degrees F	SAE 5W20 or 5W30

**DO NOT USE:** Synthetic oil, non-detergent oil or other non-recommended oils.

**DO NOT MIX** different brands of oil.

## OIL DIPSTICK CHECKS

Dipstick should be checked before starting the unit EVERY TIME.

Dipstick markings indicate upper and lower limits at a cold oil condition.

Never overfill engine oil.

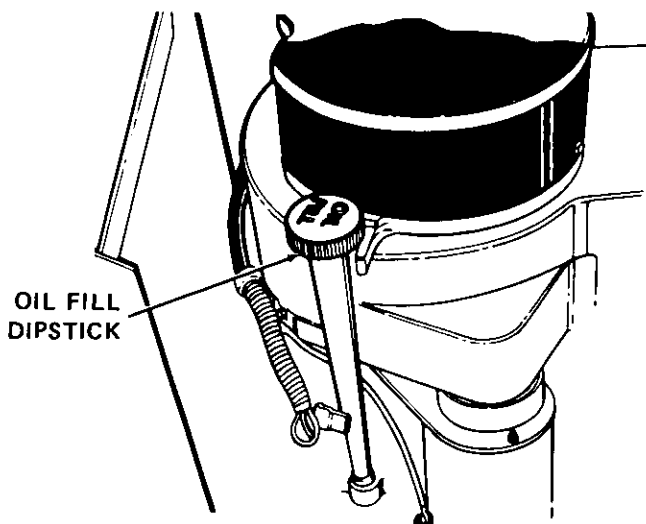

Figure 15.

### BEFORE OPERATING YOUR TRACTOR

1. Before you operate the tractor study this manual carefully. It has been prepared to help you operate and maintain your tractor with utmost efficiency.
2. Familiarize yourself with the operation of all the instruments and controls.
3. Fill the tank with either lead-free, low-lead or regular gasoline. Make sure before you fill the tank that the gasoline is clean and fresh.
4. Check tire inflation pressures.
5. Adjust the seat for operator's maximum comfort, visibility and complete control of the tractor.
6. Refer to various sections of the Owner's Manual for additional information.

### STARTING THE ENGINE



#### WARNING

Do not operate tractor if the interlock system is malfunctioning, because it is a safety device designed for protection.



#### NOTE

This unit is equipped with a safety interlock system for your protection. The purpose of the safety interlock system is to prevent the engine from cranking or starting unless the brake pedal is depressed and/or the parking brake is locked, the PTO switch is in the "OFF" position and the operator is seated. If the operator leaves the seat when the PTO is on, the engine will automatically shut off. In addition, the PTO switch must be in the off position when the unit is put into reverse or the PTO will disengage.



#### WARNING

During operation do not run the engine in confined area such as storage building any longer than is necessary. Immediately move the tractor outside into the air.

1. Operator must be seated.
2. Pull choke control button to full choke position. Less choking may be necessary due to variations in temperature, grade of fuel, etc. Little or no choking will be needed when the engine is warm.
3. Place the throttle in the "START" position. Never start engine at full throttle.
4. Place the PTO switch to the "OFF" position.
5. To start the engine, safety starting switches must be activated by pressing the brake pedal (or clutch-brake pedal on the 1220 model tractors) all the way down.
6. Place the gearshift lever (1215 Tractor) or speed control lever (1220 Tractor) in neutral ("N").



#### NOTE

On the 1220 model tractors, the speed control lever will automatically return to neutral when the brake pedal is pressed all the way down, and the linkage is properly adjusted.

7. Turn the ignition key clockwise to the "START" position and release it as soon as the engine starts; however, do not operate the starter for more than 10 seconds at any one time. If the engine does not start within this time, turn the key "OFF" and wait a few minutes, then try again.
8. After the engine starts, slowly release the brake pedal and gradually push the choke control button all the way in. Do not use the choke to enrich the fuel mixture, except as necessary to start the engine.

### STOPPING THE ENGINE



#### CAUTION

Remove the key to prevent accidental starting and battery discharge if equipment is left unattended.

1. Return gear shift lever (1215 Tractor) or speed control lever (1220 Tractor) to neutral ("N"), engage parking brake and return PTO to "OFF" position.
2. Move the throttle lever to the "SLOW" position and allow the engine to idle for a short time before stopping.
3. Then turn the key to the "OFF" position. Remove key from ignition switch.

## COLD WEATHER STARTING



### WARNING

During operation do not run the engine in confined area such as storage building any longer than is necessary. Immediately move the tractor outside into the air.



### NOTE

In cold weather the starting motor may disengage prematurely. This is caused by the engine firing once but failing to continue running. If this happens several times, the engine will be flooded and it will be necessary to leave the throttle in the "SLOW" position but push the choke in all the way; then turn the ignition key to the "START" position and slowly pull the choke out to the position which will cause the engine to start and continue running. If the engine falters after putting tractor into motion, pull the choke out part way until the engine runs smoothly, then gradually push the choke back in as the engine warms.

Engine starting is possible in cold weather providing the correct weight of engine oil is used, the battery is fully charged, and the proper starting procedure is followed. The best procedure for starting at temperatures near or below freezing is as follows:

1. Pull the choke all the way out into the full choke position.
2. Move the throttle lever to the "START" position.
3. Engage the parking brake pedal and be sure the PTO switch is in the "OFF" position. The safety interlocks will prevent starting unless this is done.
4. Move the key switch into the "START" position and hold until the engine starts; however, do not operate the starter for more than 10 seconds at any one time. As soon as the engine starts, slowly push the choke in part way.

## DRIVING THE TRACTOR (1215 Tractor)



### CAUTION

**DO NOT** shift gears while the engine clutch is engaged or while tractor is moving.



### CAUTION

The clutch pedal must be pushed all the way down in order to change gears.



### CAUTION

Do not leave the seat of the tractor without depressing the brake pedal and setting the brake lock. If leaving the tractor unattended, also turn the ignition key off and remove the key.



### CAUTION

Avoid sudden starts, excessive speed and sudden stops. Keep vehicle in gear when going down hills.



### CAUTION

Do not rest your foot on the clutch pedal while driving the tractor. This will lead to premature and excessive wear of the belt.



### NOTE

When using power take-off operated equipment, best performance is achieved with the throttle lever in the "FAST" position.

1. Disengage the clutch by pressing the clutch pedal all the way down, and release the parking brake. Move the gearshift lever to the desired speed.
2. Start the tractor in motion by slowly releasing the clutch pedal and moving the throttle lever to the position where the engine operates best for the load to be handled. If smooth engagement cannot be obtained, an adjustment to the clutch rod may be required.

## DRIVING THE TRACTOR (1220 Tractor)



### CAUTION

Avoid sudden starts, excessive speed, and sudden stops. Keep tractor in gear when going down hills.



### CAUTION

Do not leave the seat of the tractor without depressing the brake pedal and setting the parking brake. If leaving the tractor unattended, also turn the ignition key off and remove the key.



### NOTE

When using power take-off operated equipment, best performance is achieved with the throttle lever in the "FAST" position.

1. Depress the brake pedal, release the parking brake. Move the throttle lever to the position where the engine operates best for the load to be handled.
2. Start the tractor in motion by moving the speed control lever slowly forward or rearward to desired speed.

### DRIVING ON SLOPES



#### CAUTION

Always drive up or down the face of a slope. Do not drive so that the tractor may tip over sideways.

Before operating the tractor on any slope, walk the slope to look for possible hazards such as rocks, mounds, ruts, stumps or other surface irregularities which could cause an upset.

Back the tractor with implement up the steepest portion of each slope you intend to work. If the tractor cannot negotiate the slope in reverse, the slope is too steep to be worked.

Avoid turns when driving on a slope. If a turn must be made, turn down the slope. Turning up a slope greatly increases the chance of a roll over.

Avoid stopping when driving up a slope. If it is necessary to stop while driving up a slope, start up smoothly and carefully to reduce the possibility of flipping the tractor over backward.

### STOPPING THE TRACTOR (1215 Tractor Only)



#### CAUTION

Always engage parking brake, lower equipment and shut off engine before dismounting. Never try to start engine from ground.

Disengage the clutch by pressing the clutch pedal all the way down. Move gear shift lever to the "N" position and use the brake pedal to stop.

### STOPPING THE TRACTOR (1220 Tractor)



#### CAUTION

Always engage parking brake, lower equipment and shut off engine before dismounting. Never try to start engine from ground.

Move the speed control lever to the "N" position and/or push brake pedal all the way down. Before dismounting always lock the parking brake and turn the ignition "OFF". Also disengage the PTO switch.

### OPERATING THE FRONT POWER TAKE-OFF CLUTCH (PTO) (See Figure 16)

1. Move the throttle lever back to the medium or "SLOW" position.
2. Flip the toggle switch to the "RUN" (C) position.
3. Advance throttle to operating speed (full speed).
4. The operator must remain in tractor seat at all times. If operator should leave tractor seat without turning off the power take-off switch, the engine will automatically shut off.
5. PTO switch must be in the "OFF" (A) position when shifting the tractor into reverse or the PTO will shut off automatically. To re-engage the PTO, shift unit into neutral. Move PTO switch to "OFF" (A) position. Then pull knob out and lift up to "START" (B) position and release.

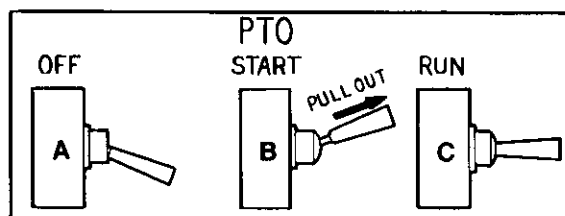

Figure 16.

## ADJUSTMENTS

### ADJUSTING THE SEAT

Before starting the tractor, adjust the seat to the most comfortable driving position. Tilt the seat forward over the steering wheel, loosen the four cap screws in the seat support, and slide the seat assembly forward or rearward to the position which is most comfortable for the operator. (See Figure 17.)

Retighten the cap screws after the seat is adjusted.

### FRAME COVER REMOVAL

To remove the frame cover, the seat assembly must be removed.

1. Remove two screws from one seat bracket. Slide seat assembly off the pin on the other seat bracket.
2. Remove screw and flat washer from frame cover as shown in Figure 17.

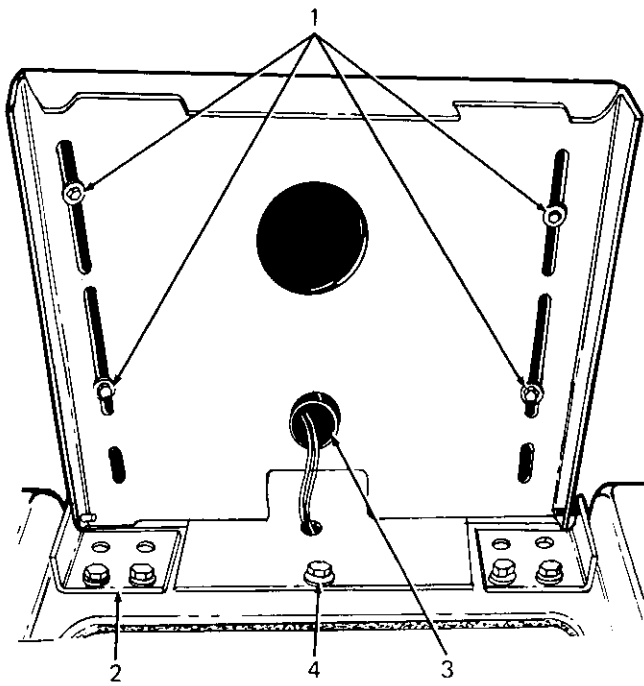

Figure 17.

1. **Seat Adjustment Bolts**
2. **Seat Bracket**
3. **Seat Switch**
4. **Screw On Frame Cover**

3. Remove two screws holding frame cover to frame in the step through area (not shown).
4. Disconnect seat switch to harness.
5. Lift up and slide frame cover rearward from underneath the pedestal.
6. Reassemble frame cover and seat assembly in reverse order. Make certain all screws are tightened securely.

#### CLUTCH ROD ADJUSTMENT (1215 Tractor)

Clutch rod adjustment is necessary when belt slippage occurs, or when clutch pedal bottoms out on the running board and does not return to the up position. If adjustment is needed, contact your authorized dealer.

#### ADJUSTING THE POWER TAKE-OFF CLUTCH



### WARNING

To avoid possible injury, always disengage all clutches, move speed control or gear shift lever into neutral, depress the brake, set the brake pedal lock and turn the ignition "OFF" before working on the machine.

The clutch is factory adjusted and should not require further adjustment under normal operating conditions. However, if the clutch fails to operate properly, check as follows:

Using a feeler gauge, check the air gap. (See Figure 18.) Insert feeler gauge into one of three access slots located around the outside of the brake plate. The air gap should be .010-.015 inch. Adjust the self-locking nuts to obtain the proper clearance. Repeat the operation in all three access slots.

### NOTE

If brake plate drags on clutch at .010-.015 inch air gap, increase air gap to .020 inch. After two hours of use, recheck and set back to .010-.015 inch.

If the above procedure does not work, see your authorized dealer.

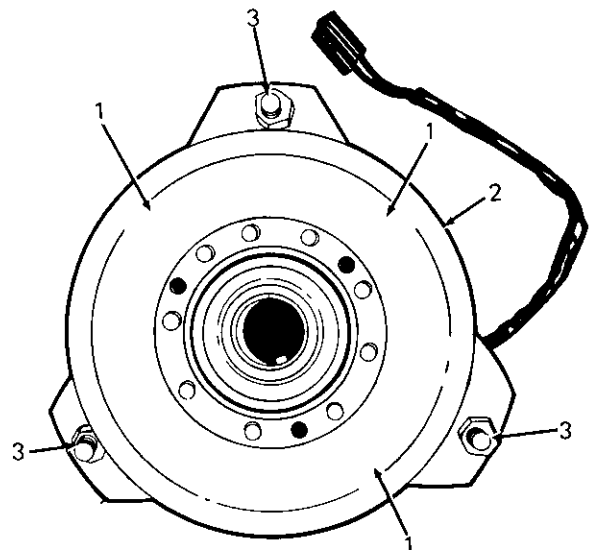

Figure 18.

1. **Access Slots**
2. **Brake Plate**
3. **Self-locking Nuts**

#### ADJUSTING THE BRAKES (1215 Tractor)

During normal operation of this machine, the brakes are subject to wear and will require periodic examination and adjustment.

To check the brake adjustment, place the gear shift lever in neutral ("N") position, lock the parking brake. You should not be able to push the tractor.

If the tractor can be pushed with the parking brake locked, or if the unit cannot be pushed with the parking brake released, brake adjustment is necessary.

To adjust the brake, proceed as follows: (See Figure 19.)

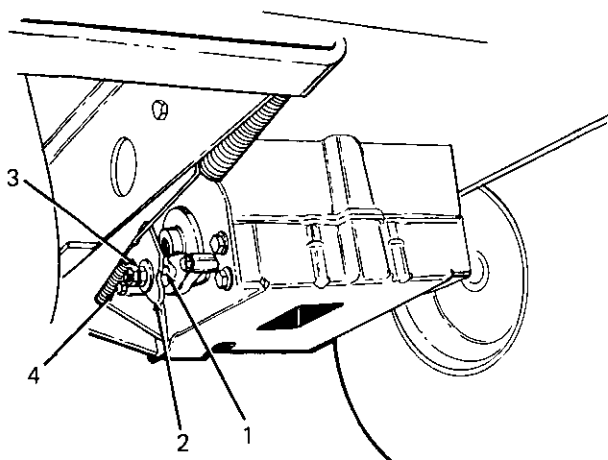

Figure 19.

1. Stop Bolt
2. Cam Lever
3. Inside Bolt
4. Outside Bolt

1. Tighten the inside nut until the cam lever cannot be moved by hand.
2. Loosen the inside nut until the cam lever can be pushed forward so that there is a 1/8 inch to 3/16 inch space between the cam lever and stop bolt.
3. Tighten the outside nut against the inside nut, using two 1/2 inch wrenches.
4. If there is no more adjustment left at the two nuts, tighten the hex nut on the end of the brake rod, under the spring. (See Figure 20.) Remove the hairpin cotter and clevis pin from the other end of the brake rod to disconnect it, and tighten the nut.

Recheck the adjustment making certain correct adjustment is reached before operating the tractor.

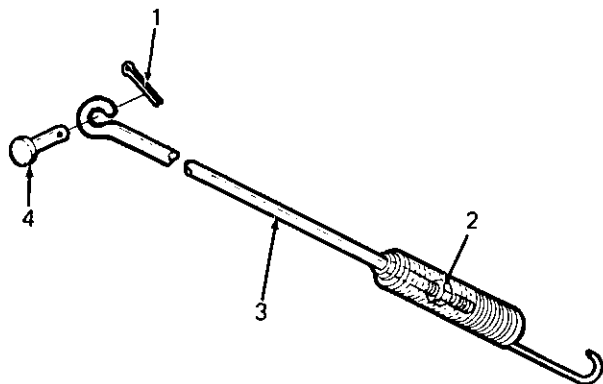

Figure 20.

1. Hairpin Cotter
2. Hex Nut
3. Brake Rod
4. Clevis Pin

### ADJUSTING THE BRAKES (1220 Tractor)

During normal operation of this tractor, the brakes are subject to wear and will need periodic examination and adjustment.

To check the brake adjustment, engage the hydrostatic dump valve so unit can be pushed. Then lock the parking brake (hydrostatic dump valve is still engaged). You should not be able to push the tractor.

If the tractor can be pushed with the parking brake locked, or if the unit cannot be pushed with the parking brake released, brake adjustment is necessary.

To adjust the brake, adjust the nut on the end of the brake rod until there is approximately 1/8 inch to 3/16 inch space between the spacer and cam lever. (See Figure 21.)

Recheck the adjustment, making certain correct adjustment is reached before operating the tractor.

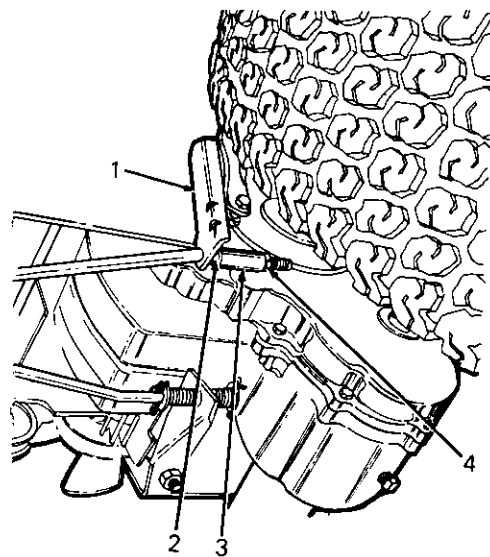

Figure 21.

1. Cam Lever
2. 1/8 inch to 3/16 inch Space
3. Spacer
4. Nut

### NEUTRAL ADJUSTMENT FOR THE SPEED CONTROL LEVER (1220 Tractor) (See Figure 22)



Spring from pedal assembly to frame strap was removed in Figure 22 for clarity only.

If the speed control lever does not return to the neutral notch on the speed control when the brake pedal is depressed, make the following adjustment:

1. Remove the cotter pin and clevis pin from turn-buckle "A" at actuating arm assembly.

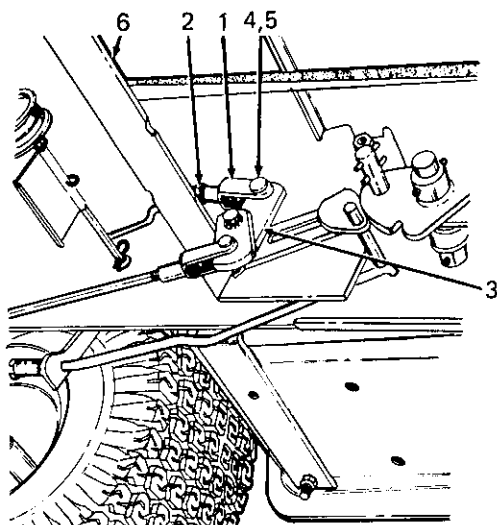

Figure 22.

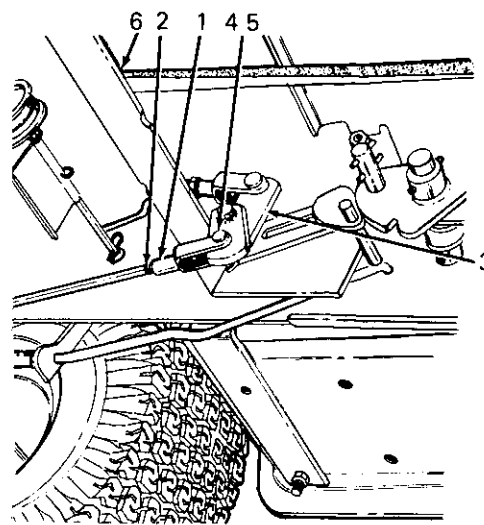

Figure 23.

1. Turnbuckle "A"
2. Hex Nut
3. Actuating Arm Assembly
4. Clevis Pin
5. Cotter Pin
6. Frame strap

2. Loosen hex nut and thread the turnbuckle "A" inward or outward, so as to move the speed control lever into the neutral position on the fender.
3. Retighten hex nut and reassemble the clevis pin and cotter pin and spread.



If the tractor creeps while the speed control lever is in neutral ("N"), the controls at the hydrostatic transmission must be adjusted.

#### HYDROSTATIC TRANSMISSION CONTROL ADJUSTMENT (1220 Tractor)

(See Figure 23)

1. Block the rear of the tractor up so both rear wheels are off the ground.
2. Remove the cotter pin and clevis pin from turnbuckle "B" at actuating arm assembly. Loosen hex nut.
3. Thread turnbuckle "B" inward or outward one or two turns.
4. Reattach turnbuckle "B" to actuating arm assembly with the clevis pin. Do not install cotter pin at this time.
5. Start the engine and run at idle speed.
6. If rear wheels do not turn, turnbuckle "B" is adjusted properly. If the wheels do turn, shut off

1. Turnbuckle "B"
2. Hex Nut
3. Actuating Arm Assembly
4. Clevis Pin
5. Cotter Pin
6. Frame strap

7. Secure the clevis pin with the cotter pin.
8. Remove blocks from under tractor and set the speed control lever in neutral ("N").
9. Start the engine, checking to see if the tractor creeps. Repeat above adjustment if necessary.

#### PIVOT BAR ADJUSTMENT BOLTS



#### CAUTION

The tractor must be checked every 50 hours of tractor operation for play between the front axle and the pivot bar adjustment bolts. Both adjustment bolt heads must fit against the front axle. If play is discovered, the pivot bar adjustment bolts must be adjusted.

If play is discovered between the front axle and the pivot bar adjustment bolt heads, adjust both bolts as follows: (See Figure 24.)

1. Loosen jam nut 3 to 4 turns or as required.
2. Turn pivot bar adjustment bolt counterclockwise until it hits against the front axle.
3. Tighten jam nut.
4. Repeat the above steps for the other pivot bar adjustment bolt.



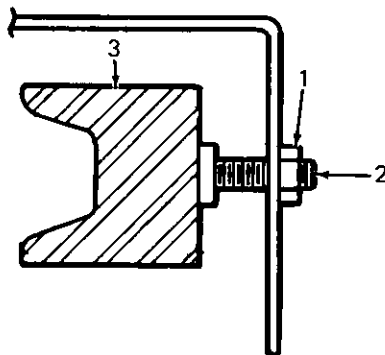
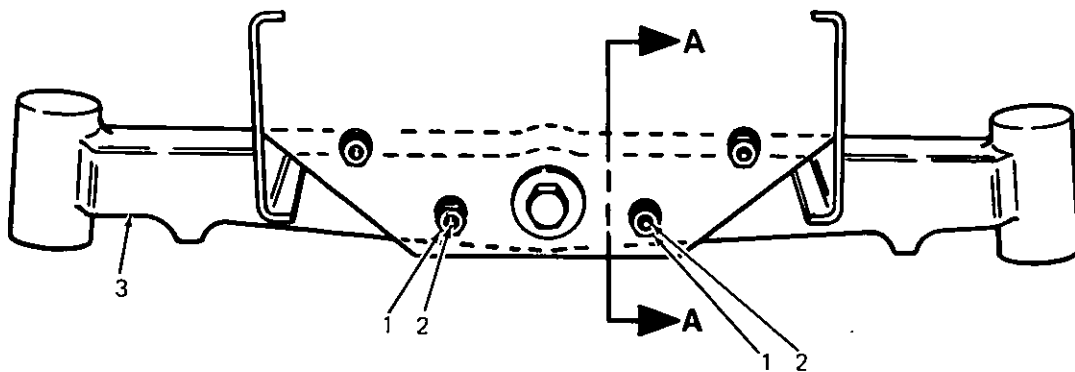

SECTION A-A

Figure 24.

1. Jam Nut
2. Pivot Bar Adjustment Bolts
3. Front Axle

### WHEEL ALIGNMENT

The front wheels should toe-in approximately 1/8 inch.

Measure the distances A and B on the front wheels.  
(See Figure 25.)

### FRONT WHEEL ADJUSTMENTS.

To adjust the toe-in remove one ball joint, loosen lock nuts "C" at the ball joint and turn the tie rod ball joint in or out as required. (See Figure 26.)



Dimension B should be approximately 1/8 inch less than dimension A.

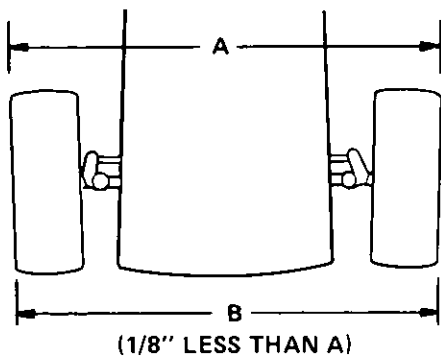

Figure 25.



Tie rod has a bend in the center for clearance of castle nut on pivot bar. Bend must remain down as shown in Figure 26.

### TURNING RADIUS



Be sure all parts are tightened after completing the following adjustment.

The front wheels should have an equal angle for left and right turns. If adjustment is necessary, remove ball joint and loosen lock nut "D". (See Figure 26.) Turn the drag link ball joint clockwise or counterclockwise as required.

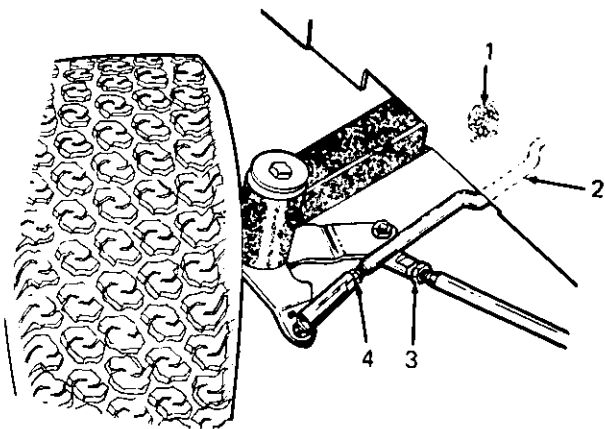

Figure 26.  
Tie Rod and Drag Link Ball Joints.

1. Castle Nut at Pivot Bar
2. Bend in Tie Rod
3. Lock Nut "D"
4. Lock Nut "C"

#### CARBURETOR ADJUSTMENTS (See Figure 27)



#### WARNING

If any adjustments are made to the engine while the engine is running (e.g., carburetor), disengage all clutches and blades. Keep clear of all moving parts and be careful of heated surfaces and muffler.



#### WARNING

To avoid injury or an accident, be sure the brake pedal is in the locked position, transmission is in neutral, and any equipment is disengaged before starting engine to make carburetor adjustments.



#### WARNING

Carbon monoxide fumes can be fatal! Do not make any adjustments to the carburetor in a confined area such as a storage building. Move the tractor outside into the air.

**INITIAL ADJUSTMENT** — Turn idle and needle valves clockwise until they close (see Figure 27).



#### CAUTION

Valves may be damaged by turning them too far.

Now open high speed needle valve 1-1/2 turns counterclockwise and idle valve 1-1/4 turns. This initial adjustment will permit the engine to be started and warmed up prior to final adjustment.



#### NOTE

Carburetor adjustments should be made with the air cleaner on engine.

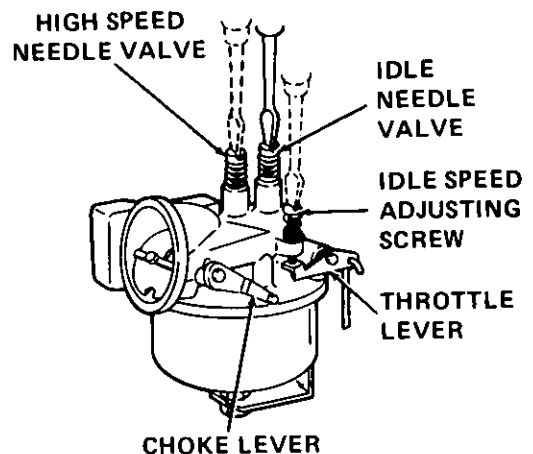

Figure 27. Carburetor Adjustment

#### FINAL ADJUSTMENT PROCEDURE

##### Idle Valve Mixture

Place throttle control lever in "SLOW" position. Set idle speed adjusting screw to obtain 1750 R.P.M. minimum while holding throttle lever against screw. Turn idle valve in until R.P.M. slows or misses (clockwise — lean mixture), then turn it out past smooth idling point until engine runs unevenly (rich mixture). Now turn idle valve to the midpoint between rich and lean so the engine runs smoothly. Release throttle lever.

##### GOVERNED IDLE

Turn idle speed adjusting screw to obtain 1600 R.P.M. while holding throttle lever against screw. Release throttle lever. Align holes in control bracket and inside lever with 1/8 inch diameter rod. Throttle control lever should be in "SLOW" position. Adjust if necessary. Bend spring tang to obtain 1750 R.P.M. Remove 1/8 inch diameter rod (see Figure 28).

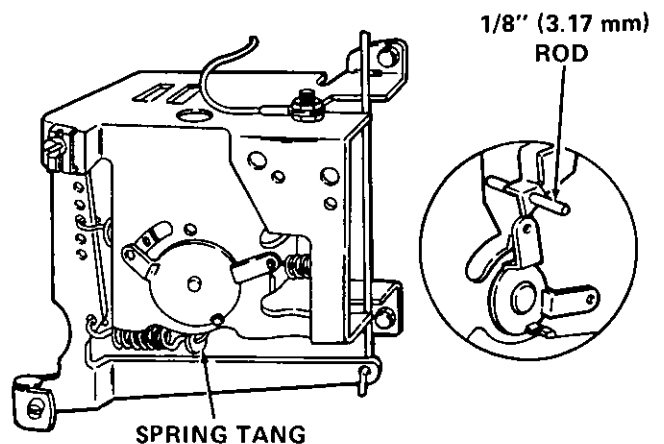

Figure 28. Governed Idle Adjustment

### Needle Valve Mixture (High Speed)

Move throttle control lever to "FAST" position. Turn needle valve in until engine slows or misses (lean mixture), then turn it out past the smooth operating point until engine runs unevenly (rich mixture). Now

turn needle valve to the midpoint between rich and lean so the engine runs smoothly (see Figure 27).

Engine should accelerate smoothly. If engine does not accelerate properly, the carburetor should be re-adjusted usually to a slightly richer mixture.

## MAINTENANCE

### ENGINE OIL

The engine crankcase is filled with ship-away oil. This oil may be used for the first 5 hours of engine operation at temperatures between 0 degrees F. and 90 degrees F. If temperatures are not within this range, drain the oil from crankcase and replace with new oil as specified in the "LUBRICATION TABLE". The engine oil must be drained and replaced with new oil every 25 hours of engine operation.

To aid starting, the selection of crankcase lubricating oils should be based on the lowest anticipated temperatures until the next drain period.

*Cub Cadet* Low Ash Engine Oil meeting API Service Classification SF is recommended. For maximum engine life select API SF oils with lowest levels of barium, calcium, or magnesium additives and minimum ash content (approximately 0.5%). Lubricant suppliers will normally furnish this information on their engine oils.

Multi-viscosity numbered oils such as SAE 10W-30 or SAE 10W-40 can be used above 32 degrees Fahrenheit.

Regularly check the oil level of the engine crankcase to see that it is filled to the correct level. Always keep the oil level between the "FULL" and the "LOW" marks on the dipstick. When checking the oil level the dipstick must be withdrawn and wiped clean, then inserted all the way and withdrawn for a true reading.

### NOTE

Check the oil level only while the engine is stopped and tractor is level.

### NOTE

During initial break-in period the engine oil level should be checked prior to every use.

### FILLING THE CRANKCASE

To fill the crankcase with oil, place the tractor on a level surface. Clean the area around the oil fill tube and dipstick to prevent debris from entering the crankcase.

### NOTE

Never overfill the engine crankcase. Engine may overheat and/or damage may result if the crankcase is below the "LOW" mark or over the "FULL" mark. For oil capacity refer to the "SPECIFICATIONS" and "LUBRICATION TABLE" sections.

Remove the oil fill cap and dipstick and fill to the full mark on the dipstick. POUR SLOWLY. The oil capacity is 3 pints. When checking the oil level, push the dipstick assembly firmly but slowly until cap bottoms on tube. DO NOT OVERFILL. Dipstick assembly MUST BE PUSHED FULLY INTO TUBE AT ALL TIMES WHEN ENGINE IS OPERATING.

### AIR CLEANER

#### Servicing Foam Pre-Cleaner Element

Clean and re-oil foam pre-cleaner element at 1-month intervals or every 10 hours, whichever occurs first.

### NOTE

Service more often under dusty conditions.

1. Remove wing nut and cover. (See figure 29.)
2. Remove foam pre-cleaner element by sliding it up off the paper cartridge.
3. A. Wash pre-cleaner element in liquid detergent and water.  
B. Squeeze dry in cloth.  
C. Saturate in engine oil. Squeeze to distribute oil evenly.  
D. Wrap in shop towel and squeeze to remove excess oil.

Discard used element and replace with new one at least once a year.

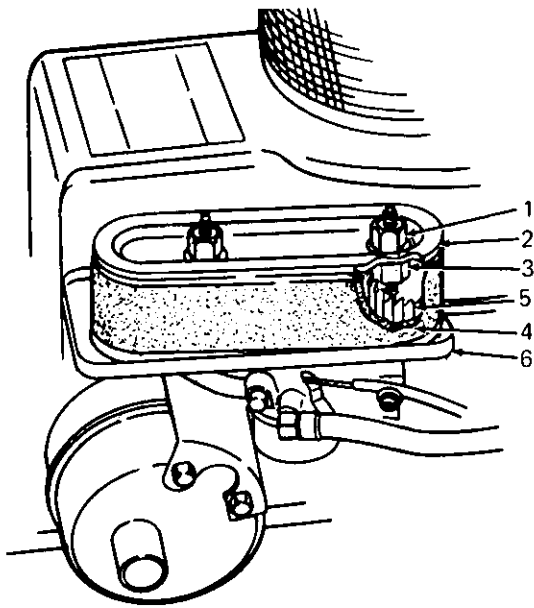

Figure 29. Air Cleaner Assembly

- |              |                             |
|--------------|-----------------------------|
| 1. Wing Nuts | 4. Paper Cartridge          |
| 2. Cover     | 5. Foam Pre-cleaner Element |
| 3. Hex Nuts  | 6. Backplate                |

#### SERVICING PAPER CARTRIDGE

This engine is equipped with a dry type air cleaner element, which should be checked every 100 operating hours and replaced if dirty. It should be checked and if necessary replaced more often under extremely dirty, dusty conditions. Do not wash element in any liquid or attempt to blow dirt off with air hose as this will puncture filter element. Carefully handle new element — do not use if gasket surfaces are bent or twisted. Check the following when installing a new element: (See Figure 29.)

1. Backplate must be flat on gasket of carburetor elbow. Replace backplate if bent or cracked.
2. Gasket surfaces of element must be flat against backplate and cover to seal effectively.
3. Seal on cover must be in place to reduce noise and vibration of the cover. Vibration can cause stud hole in cover to enlarge, thus permitting dirt to enter carburetor.
4. Wing nuts must be finger tight — do not overtighten.

Properly cleaned and installed air cleaner elements are the best guarantee to continued long and satisfactory engine life.

#### CLEANING ENGINE

This tractor has an air-cooled engine. Air must be able to circulate freely around the engine, through the screen, shroud, and over the fins of the cylinder head and cylinder block. Keep these areas free of accumulated dirt and trash or engine will overheat and result in damaged moving parts.

#### SPARK PLUGS



#### WARNING

To avoid possible injury, be sure engine is off and cool before making any adjustment or repairs.



#### NOTE

Remove all dirt from around the spark plugs before removing.

To remove spark plugs, always use a spark plug wrench. Check gap after every 100 hours of operation.

Replace a defective plug with a new plug. Set gap at .030 inch. (See Figure 30.) Tighten plug to 10-15 ft-lbs. See your authorized dealer for the correct replacement plug.

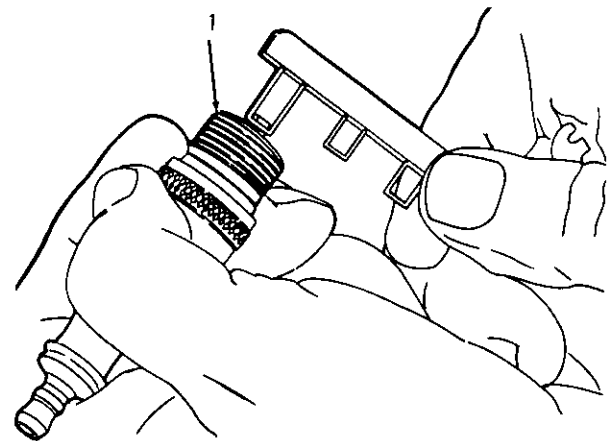

Figure 30.

1. Spark Plug

#### CLEANING OF CYLINDER HEADS

Cleaning of the cylinder heads should only be done by your authorized *Cub Cadet* Dealer. This process is to be done to keep your engine properly cooled and at its peak efficiency. The frequency of cleaning is dependent upon the type of fuel used. When leaded fuel is used the cleaning interval is more frequent than with unleaded fuel. The cylinder head should also be cleaned more frequently when the unit is run under a constant load. The cleaning interval is from 100 to 300 hours.

#### FIVE SPEED TRANSMISSION (1215 Tractor)

The transmission is lubricated and sealed at the factory and does not require checking. If disassembled for any reason, lubricate with 24 ounces of E.P. Lithium grease.

#### HYDROSTATIC TRANSAXLE (1220 Tractor)

Check the oil level four times a year. Lubricant should be at the point of overflowing. Use SAE E.P. 90 oil. Drain and refill every two years. The capacity is 2-3/4 pints.

## HYDROSTATIC OIL LEVEL (1220 Tractor)



### CAUTION

Never use a multi-viscosity oil.

The transmission has been filled at the factory and should not require changing for the life of the transmission. The following oils can be used: Texaco 2209, General Motors Dextron B, Ford M2C-33F, Mobile Fluid 300, *Cub Cadet* hydraulic fluid or a good quality SAE 20 high detergent oil.



### CAUTION

Overfilling reduces the expansion area in the reservoir/expansion tank and fluid will spill at operating temperatures.

The transmission fluid level should be checked prior to initial use. The level should not be above the "COLD" mark which is about 1/4 inch from the bottom of the reservoir/expansion tank. (See Figure 31.)

To check or add fluid to the transmission: (See Figure 31.)

1. Remove the seat and frame cover. Refer to "FRAME COVER REMOVAL" in the "ADJUSTMENT" section.
2. Check the oil level in the reservoir/expansion tank.
3. If it is necessary to add oil, unscrew the cap on the reservoir/expansion tank and add oil through the hole with a funnel. Do not overfill.
4. Reassemble parts.

If frequent additions are required, locate the leak and correct. Inadequate supply of fluid may result in permanent internal damage.

If contaminant is observed on the reservoir/expansion tank screen, poor maintenance is indicated. Remove the reservoir/expansion tank, wash clean, dry and reinstall. If the screen is pierced, the reservoir/expansion tank should be replaced.



### NOTE

The threads on the reservoir/expansion tank are left hand threaded.

If the natural color of the transmission fluid has changed to black or milky, overheating and/or water contamination is indicated. The fluid should be drained and replaced with new transmission fluid.

To drain the hydrostatic transmission, remove the hex plug on the bottom of the transmission.

To fill the hydrostatic transmission, remove the vent plug located next to the reservoir/expansion tank to prevent an air lock. Replace vent plug. (See Figure 31.)

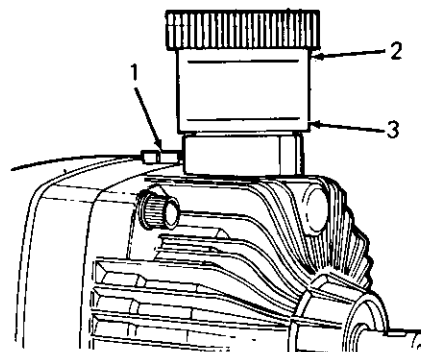

Figure 31.

1. Vent Plug
2. Oil Level Hot
3. Oil Level Cold

## HYDROSTATIC TRANSMISSION COOLING (1220 Tractor)



### CAUTION

Do not use high pressure water spray or steam to clean the hydrostatic transmission.

The hydrostatic transmission is cooled by the oil, fan and fins. Normal operating temperature is 180 degrees F. If the transmission runs hot, check to see if the fan is in operating condition, the oil level is correct and the fins are clean.

## DRIVE BELT ADJUSTMENT (1220 Tractor)

If a reduction in speed is noticed, the drive belt may need adjustment. Adjust as follows: (See Figure 32.)

1. Loosen (do not remove) the hex bolt and nut at the stationary idler bracket.
2. Slide the idler pulley upward to tighten the belt. Tighten hex nut and bolt.

When no adjustment is left, have belt replaced.

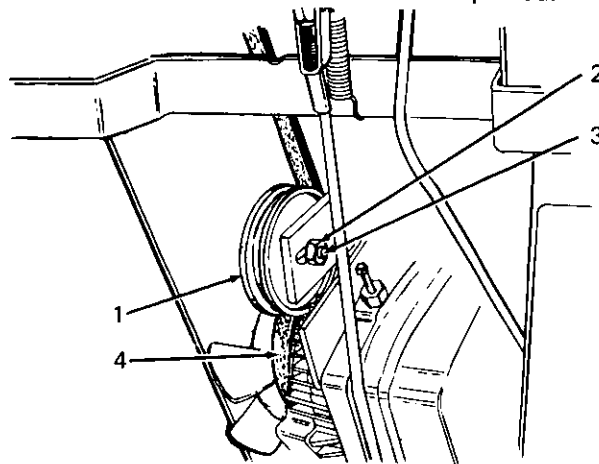

Figure 32.

1. Idler Pulley
2. Hex Nut
3. Bolt
4. Drive Belt

## DRIVE BELT REPLACEMENT

If drive belt replacement is required, contact your authorized *Cub Cadet* Dealer.

## BATTERY INFORMATION



### WARNING

- A. Battery acid must be handled with great care as contact with it can burn and blister the skin. It is also advisable to wear protective clothing (goggles, rubber gloves and apron) when working with it.\*
- B. Should battery acid accidentally splatter into the eyes or onto the face, rinse the affected area immediately with clean cold water. If there is any further discomfort, seek prompt medical attention.
- C. If acid spills on clothing, first dilute it with clean water, then neutralize with a solution of ammonia/water or baking soda/water.
- D. Since battery acid is corrosive, do not pour it into any sink or drain. Before discarding empty electrolyte containers, rinse them with a neutralizing solution.
- E. NEVER connect or disconnect charger clips to battery while charger is turned on as it can cause sparks.
- F. Keep all lighted materials (cigarettes, matches, lighters) away from the battery as the hydrogen gas generated during charging can be combustible.
- G. As a further precaution, only charge the battery in a well-ventilated area.

\*Always shield eyes and protect skin and clothing when working near batteries.



### DANGER

BATTERIES CONTAIN SULFURIC ACID AND MAY CONTAIN EXPLOSIVE GASES (when electrolyte has been added).

KEEP BATTERIES OUT OF THE REACH OF CHILDREN.

## MAINTENANCE OF BATTERY

1. Check electrolyte level periodically (at least every two weeks). Keep the level to the split rings. Use only distilled water or a good quality drinking water. Never add acid or any other chemicals to the battery after initial activation.
2. The battery should be checked with a hydrometer after every 25 hours of operation. If the specific

gravity is less than 1.225, the battery should be recharged. Maximum charge rate 5 amps.

3. Coat the terminals and exposed wire with a thin coat of grease or petroleum jelly for longer service and protection against corrosion.
4. The battery should be kept clean. Any deposits of acid should be neutralized with baking soda and water. Be careful not to get this solution in the cells.
5. Avoid tipping the battery. Even a "sealed" battery will leak electrolyte when tipped.

## STORAGE OF THE BATTERY

1. When storing battery for extended periods, disconnect battery cables. Removing battery from unit is recommended.
2. Keep the exterior of the battery clean, especially the top. A dirty battery must be stored with a full charge. A dirty battery will discharge itself.
3. Check the battery with a hydrometer. The battery must be stored with a full charge. A discharged battery will freeze.

### Specific Gravity

1.265  
1.250  
1.200  
1.150  
1.100

### Freezing Point

-71°F  
-62°F  
-16°F  
5°F  
16°F



### NOTE

All batteries discharge during storage.

4. Recharge battery whenever the specific gravity is less than 1.225, before returning to service or every two months, whichever comes first.

## COMMON CAUSES FOR BATTERY FAILURE

1. Overcharging
2. Undercharging
3. Lack of water
4. Loose hold downs and/or corroded connections
5. Excessive loads
6. Battery electrolyte substitutes
7. Freezing of electrolyte



### NOTE

These failures do not constitute warranty.

## BATTERY REMOVAL OR INSTALLATION



### WARNING

When removing the battery, follow this order of disassembly to prevent your wrench from shorting against the frame.

1. Remove the Negative cable.
2. Remove the Positive cable.

#### To install a battery:

1. Attach the Positive cable.
2. Attach the Negative cable.

## JUMP STARTING



### WARNING

Failure to use this starting procedure could cause sparking, and the gases in either battery could explode.

1. Attach the first jumper cable from the positive terminal of the good battery to the positive terminal of the dead battery.
2. Attach the second jumper cable from the negative terminal of the good battery to the **FRAME OF THE UNIT WITH THE DEAD BATTERY.**

## TIRES

Keep the pneumatic tires properly inflated. Overinflation will cause operator discomfort. Underinflation will cause short tire life.

Inflate the front and rear tires for normal or heavy load operations as shown in the following table:

TIRE SIZE	POUNDS PER SQUARE INCH
Front Tires 15 x 6-6	12
Rear Tires 20 x 10-8	10

Always see that the tire valve caps are in place and tightened securely to prevent loss of air and protect the valve core and stem.

Do not overload the tractor tires by mounting equipment on the tractor which exceeds the load capacity of the size of the tires on the tractor.

#### MOUNTING TIRES ON THE RIM

After mounting a new or old tire on the rim, inflate it to 20 pounds pressure to seat the tire bead on the rim flange. Then deflate the tire to the correct operating pressure.



### NOTE

After the first 10 hours of operation, check and retorque the front wheel bolts to 35 ft-lbs. and rear wheel bolts to 23 ft-lbs. to make sure they have seated properly.

## OFF-SEASON STORAGE

If the machine is to be inoperative for a period longer than 30 days, the following procedures are recommended:

1. Refer to engine manual for engine storage procedures.
2. Clean the engine and the entire tractor thoroughly.
3. Lubricate all lubrication points and wipe the entire machine with an oiled rag in order to protect the surfaces.
4. Follow battery storage instructions on page 23.
5. Protect tires and seat from sunlight. Inflate tires at regular intervals.

## OPTIONAL EQUIPMENT AND ACCESSORIES

When you purchased your tractor, you probably had it completely equipped for your particular needs at the time. However, later you may wish to obtain optional equipment or accessories. These items and other allied equipment can be purchased from, and installed by, your authorized dealer.

The tractor is used for so many different types of work, and because it is called on to operate under so many different conditions, a variety of equipment is available to adapt it to the requirements of the user. Refer to equipment catalog.

## MOWING DECK — ADJUSTMENTS AND OPERATION

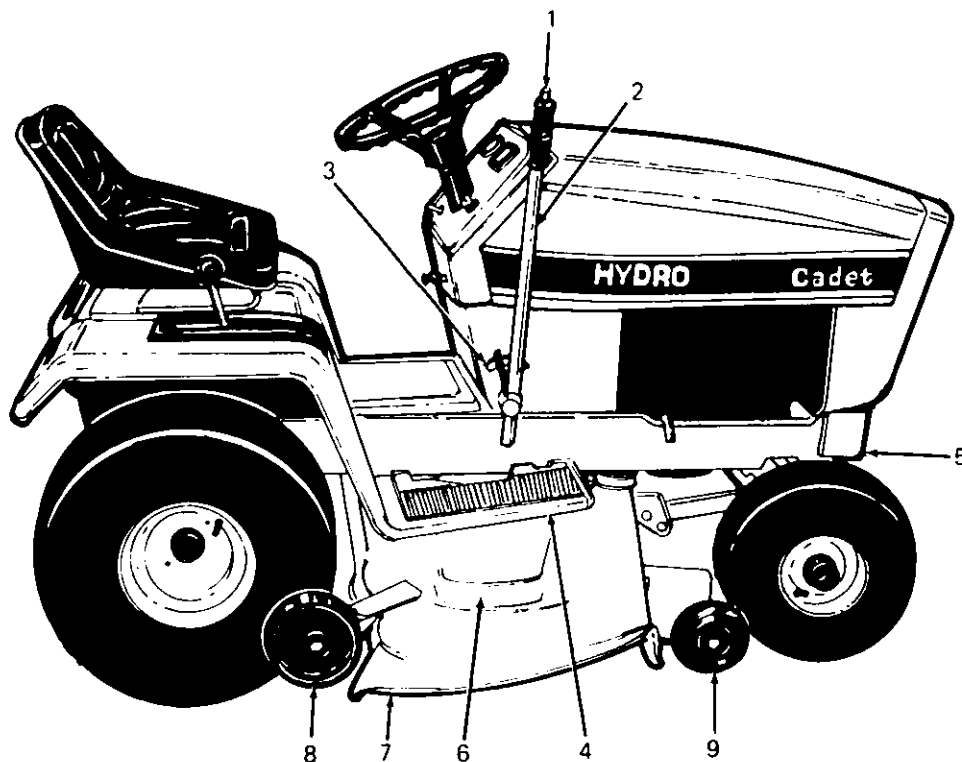

Figure 33. MOWER DECK PARTS AND ATTACHMENTS (44 inch deck shown)

- |                              |                     |
|------------------------------|---------------------|
| 1. Lift Lever Release Button | 6. Belt Cover       |
| 2. Lift Lever                | 7. Deflector Shield |
| 3. Lift Lever Position Decal | 8. Gauge Wheels     |
| 4. Mower Support Hangers     | 9. Roller           |
| 5. Quick Hitch Rod           |                     |

### SIDE TO SIDE LEVELING ADJUSTMENT

#### WARNING

Before making any adjustments, turn off the machine, remove the key and lock the parking brake to avoid accidental starting and injury.

#### CAUTION

If the mower deck is not level, the mower will not cut your lawn evenly.

#### NOTE

Check the tires for proper inflation before making a level and height adjustment. To level the mower, place the tractor on a level and hard surface such as a garage floor or sidewalk.

The 38 and 44 inch mowers are equipped with two adjustable lift links. This feature allows the mower to be leveled. (See Figure 34.)

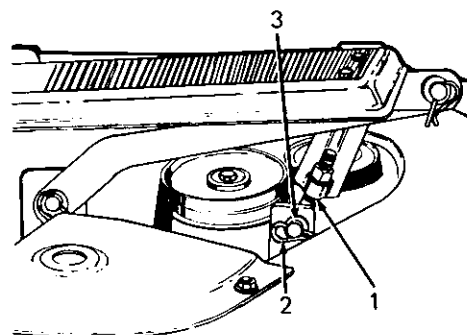

Figure 34. (Right Hand Side Shown) (44 inch Deck)

1. Adjustable Lift Link
2. Hairpin Cotter
3. Flat Washer

To check the side to side leveling of the mower deck, place the unit on a hard level surface. Disconnect the spark plug wires. Place the two outer blades parallel to the unit. Measure the distance from the tip of the blades to the surface on each side. (See Figure 35.)



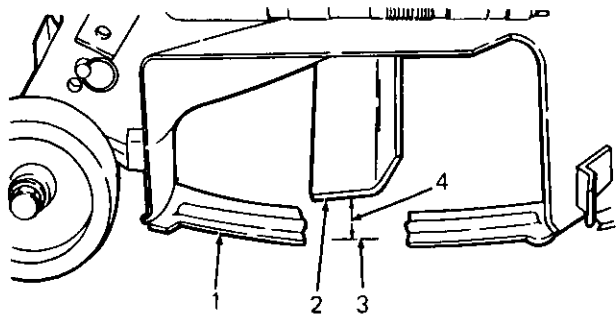

Figure 35.

1. Deflector Shield
2. Blade
3. Hard Surface
4. Measure This Distance

If the measurements are not equal, lower the mower deck to the ground. Disconnect one of the adjustable links by removing the hairpin cotter and flat washer which secure it to the deck. Turn the end of the link to the right or left as needed. Reconnect the adjustable link and raise the deck. Recheck the measurement on each, and repeat adjustment until distances are equal.

#### CUTTING HEIGHT

The mower can be set in multiple positions. Pull the lift handle back slightly and depress button on the top of lift handle. Release the button when the desired mower position is obtained. To return the mower to a specific position, note the position of the lift lever pointer in relation to the lever position decal before raising or lowering the mower.

#### GAUGE WHEELS AND CASTERS (44 inch Decks)

Set the gauge wheels and casters just off the hard surface by locating in the proper holes. The gauge wheels and casters prevent scalping and are not meant to set the cutting height. Gauge wheels and casters must be set in the same relative hole locations. (See Figure 36)

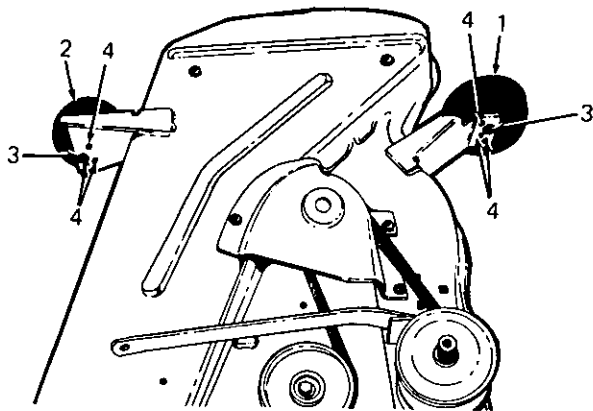

Figure 36. (44 inch Deck)

1. Gauge Wheel
2. Caster
3. 3/8 inch Nut and Lock Washer
4. Adjustment Holes

#### GAUGE WHEELS (38 inch Deck)

Adjust the height of the gauge wheels by pulling out the quick release pin and slide the gauge wheel bracket up or down until desired height is reached. Reinstall the quick release pin. Note that there are half height adjustment holes along with the adjustment holes in the gauge wheel bracket. Both gauge wheels must be set in the same relative hole locations. (See Figure 37)

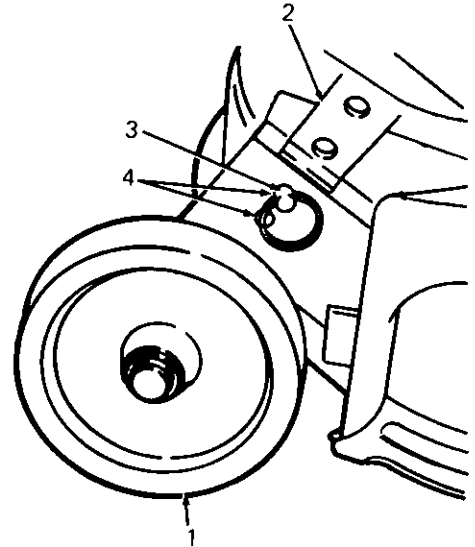

Figure 37. (38 inch Deck)

1. Gauge Wheel
2. Gauge Wheel Bracket
3. Quick Release Pin
4. Half Height Adjustment Holes

#### STARTING THE MOWER



In heavy grass, full throttle may be needed when starting the mowing deck.

With the engine running at idle speed, start the power take-off clutch (see page 13, Figure 16). Starting the mower with the engine in idle will reduce wear on the drive belt. Increase engine speed to full throttle.

#### STOPPING THE MOWER

Move the power take-off (PTO) switch to "OFF" and reduce engine speed.

#### CLEANING AND BLADE CARE



#### WARNING

Stop the tractor, disengage the PTO, place all controls in neutral, engage the parking brake lock and stop the engine before performing any maintenance.



## WARNING

Be careful not to cut yourself when sharpening the blades or cleaning the underside of the mower.

Clean the underside of the mower at the end of the mowing season and when the build-up of cut material on the underside is noticed. Also remove the belt cover and remove any accumulation.

The cutting blades must be kept sharp at all times.



## NOTE

Sharpen ends evenly so that the blades remain balanced and the same angle of sharpness is maintained. However, if the cutting edge of a blade has been sharpened to within 3/8 inch of the wind wing, it is recommended that new blades be installed. New blades are available at your authorized dealer.

When removing the blades, hold the hex shaped pulley hub with a 1-1/4 inch socket wrench to remove the hex nut holding the blade. A block of wood may be placed between housing and cutting edge of blade to assist in removal of hex nut securing blade. (See Figure 38)

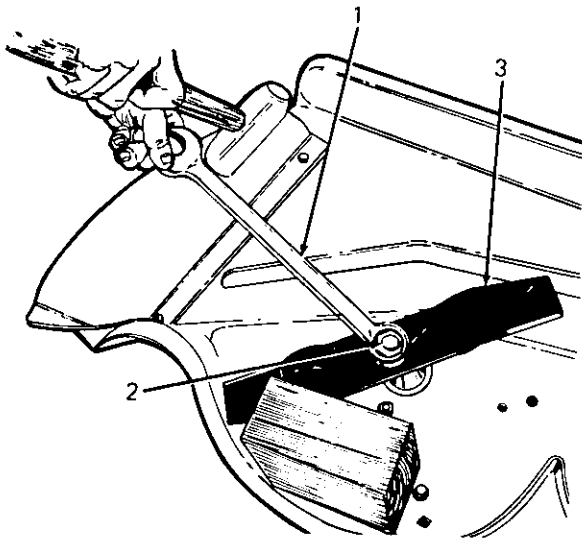

Figure 38.

1. 1-1/8 inch Wrench
2. Hex Nut
3. Blade

After replacing blades, grease the threaded end of the shaft to prevent rust build-up.

When replacing the blades, be sure they are assembled so the cutting edges are in the direction of rotation with the wind wings pointed upward. Tighten the nuts 50 to 60 ft-lbs. (68 to 81 N-m).



## NOTE

If the spindle pulley nuts are removed for any reason, they should be retightened to 90 to 110 ft-lbs. torque when replaced.

## LUBRICATION

After every 100 hours of operation, and/or before putting into winter storage, lubricate the spindle assemblies using 251H EP grease or equivalent No. 2 multi-purpose lithium grease. The grease will be expelled from the top spindle seal. Since the spindle pulley covers the top spindle seal, the expelled grease cannot be seen. When the spindle is fully greased, the expelled grease will cause the top spindle seal to give off a muffled crackling noise. (See Figure 39 for the 38 inch deck or Figure 40 for the 44 inch deck.)

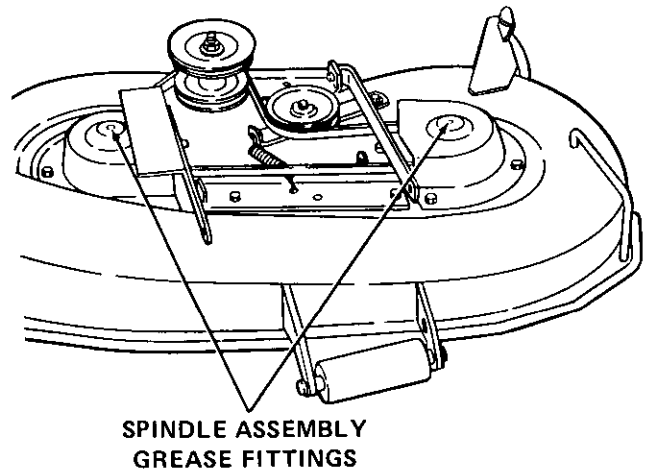

Figure 39. (38 Inch Deck)

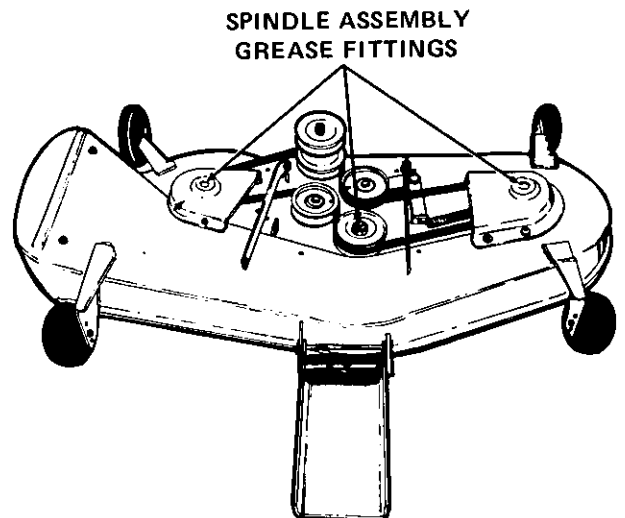

Figure 40. (44 Inch Deck)

**SPINDLE DRIVE BELT REPLACEMENT (38 Inch Deck)**

Replace spindle drive belt as follows: (See Figures 41, 42 and 43.)

1. Remove the nuts and washers that secure both spindle belt covers to the deck.
2. Remove the spindle belt covers to expose the belt.
3. Push against the idler pulley to release tension on drive belt.
4. Remove old drive belt.
5. Install a new belt. Refer to Figures 41, 42 and 43 for proper placement of belt. Push against idler pulley to aid the installation.
6. Reinstall spindle belt covers and hardware.

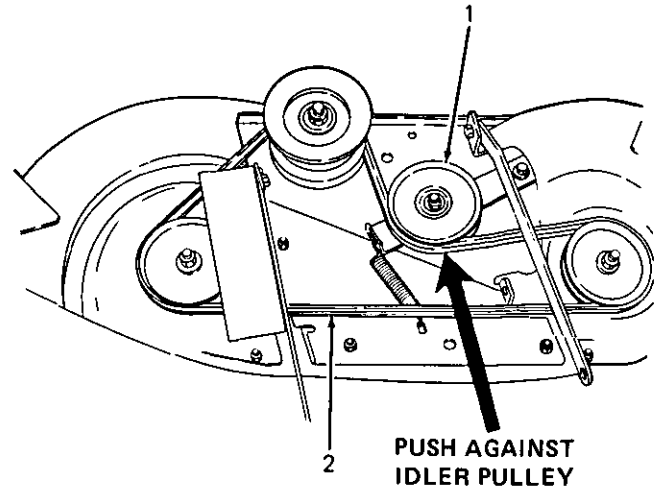

Figure 43.

1. Idler Pulley
2. Spindle Drive Belt

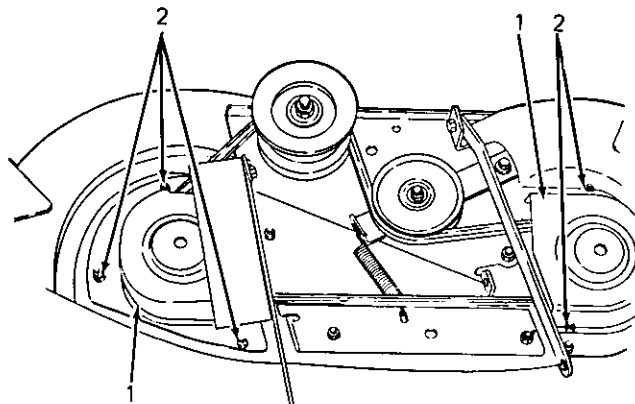

Figure 41.

1. Spindle Belt Cover
2. Nuts and Washers

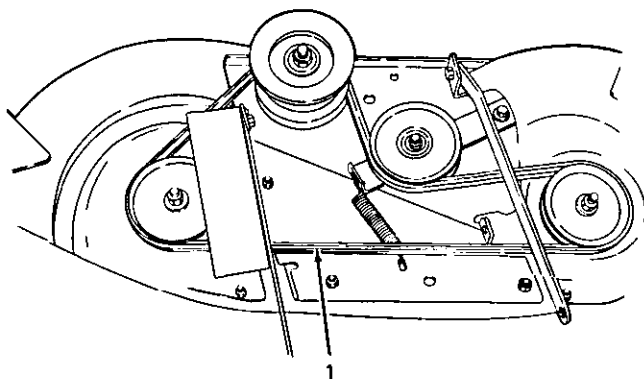

Figure 42.

1. Spindle Drive Belt

**SPINDLE DRIVE BELT REPLACEMENT (44 inch Deck) (See Figures 44, 45 and 46)**

To replace spindle drive belt, remove belt covers. Release spring tension. Remove the old belt. Install the new belt around pulleys as shown in Figures 44, 45 and 46. Be certain belt is in lower groove of the center pulley. Reinstall covers.

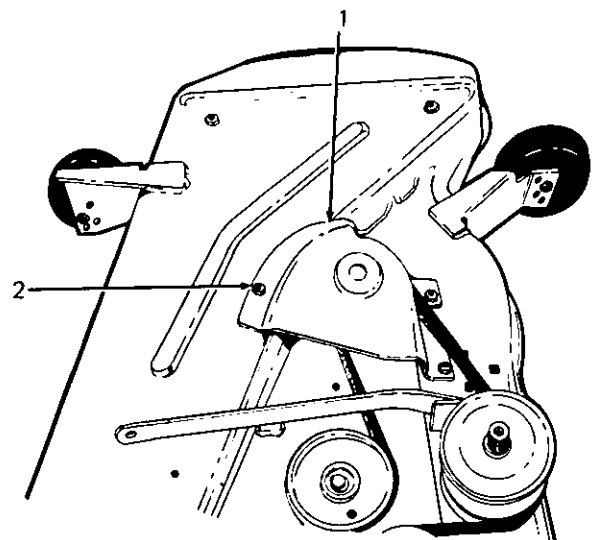

Figure 44.

1. Spindle Belt Cover
2. Nuts and Washers

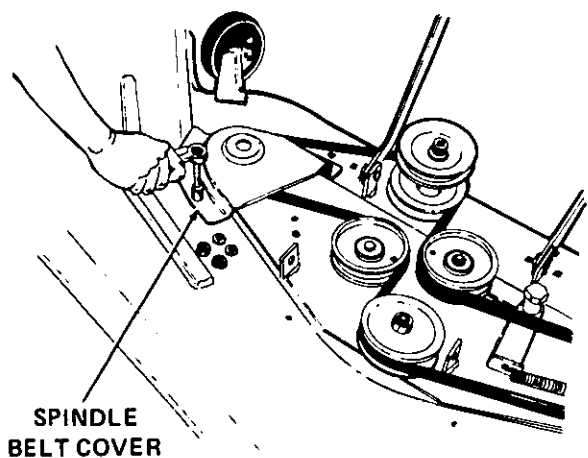

Figure 45.

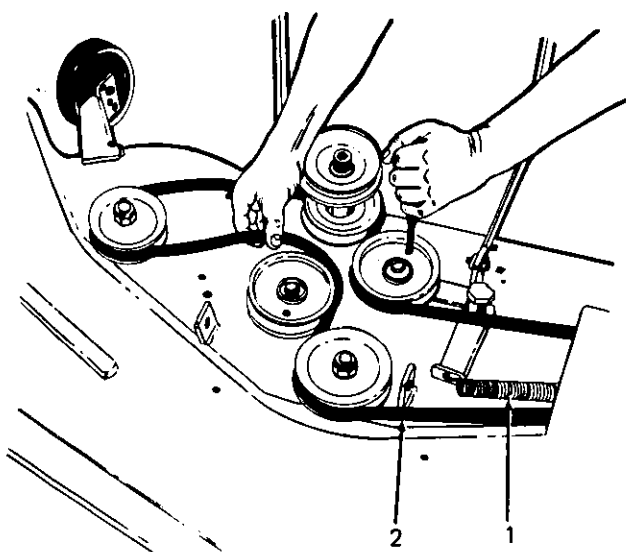

Figure 46.

1. Idler Spring
2. Spindle Drive Belt

**MOWING**



**WARNING**

To avoid possible injury, do not allow anyone in the area opposite the discharge chute while mowing. Although the area has been supposedly cleared of foreign objects, small objects may have been overlooked and may be discharged by the mower.



**WARNING**

Never direct discharge of material toward bystanders nor allow anyone near the machine while in operation.

For best results it is recommended that the first two laps should be cut with the discharge thrown towards the center. After the first two laps, reverse the direction to throw the discharge to the outside for the balance of cutting. This will give a better appearance to the lawn.

Do not cut the grass too short, as the mower will tend to scalp the grass. Short grass invites weed growth and yellows quickly in dry weather.

Mowing should be done with the engine at full throttle. Do not mow at high ground speed.

During certain times of the year and under some conditions, the mower may leave streaks of uncut material.

Streaking may occur when attempting to mow heavy weeds and tall grass. Under these conditions it may be necessary to go back over the cut area a second time to get a clean cut.

The following practices will help eliminate streaking:

1. Mow the area more often so the grass doesn't get too tall and heavy.
2. Operate the tractor at full throttle and lower forward speeds.
3. Keep the blades sharp and replace blades when worn.
4. Follow the mowing procedure shown in Figure 47.

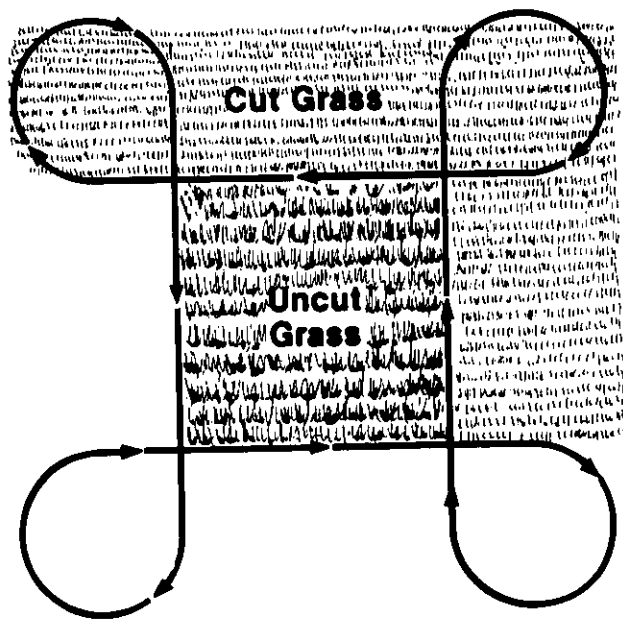

Figure 47.

## ATTACHING MOWER TO TRACTOR

### NOTE

Figures 48 through 53 illustrate attaching the mower deck to the tractor. The 38 inch deck is shown, but is typical of both the 44 inch deck and the 38 inch deck.

1. Assemble the front hanger assembly to the tractor as shown in Figure 48.

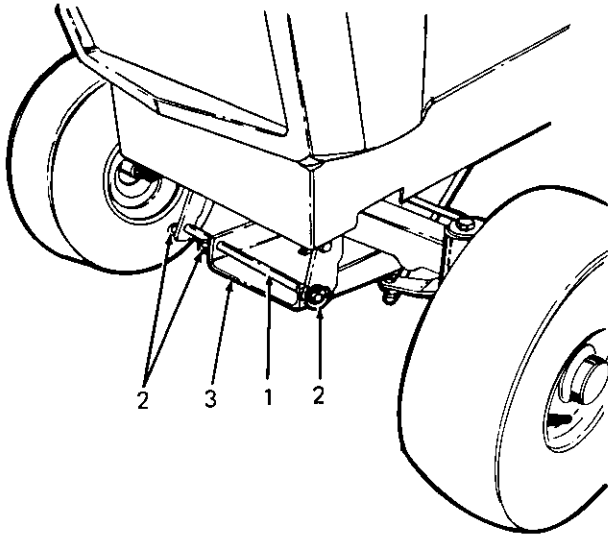

Figure 48.

1. Hanger Rod
  2. Hairpin Cotters and Flat Washers
  3. Front Hanger Assembly
2. Attach deck hangers and adjustable lift links using hairpin cotters and flat washers as shown in Figures 49 and 50.

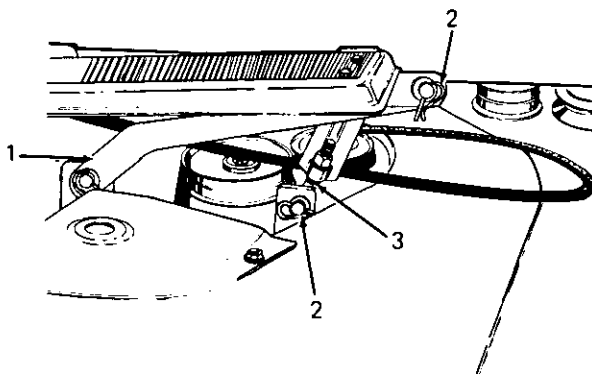

Figure 49. Right Side of Deck

1. Deck Hanger
2. Hairpin Cotter and Flat Washer
3. Adjustable Lift Link

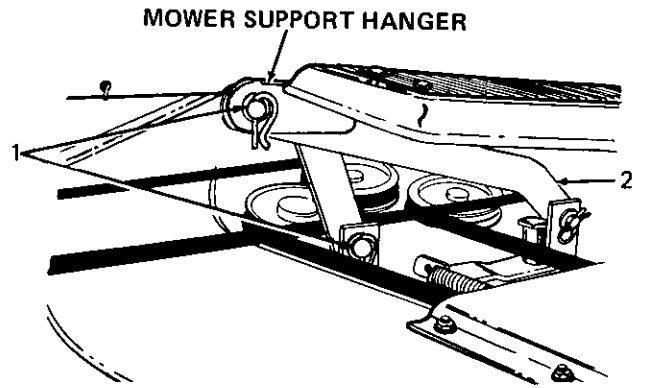

Figure 50. Left Side of Deck

1. Hairpin Cotter and Flat Washer
  2. Deck Hanger
3. Install spindle belt by slipping belt over electric PTO pulley. (See Figure 51.)

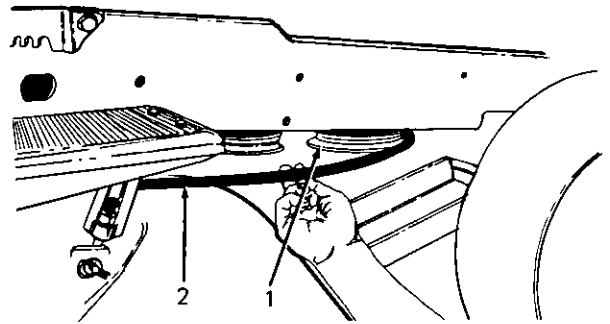

Figure 51.

1. Electric PTO Pulley
  2. Drive Belt
4. Pull idler pulley away from the tractor and then place drive belt behind it. Release idler pulley. (See Figure 52.)

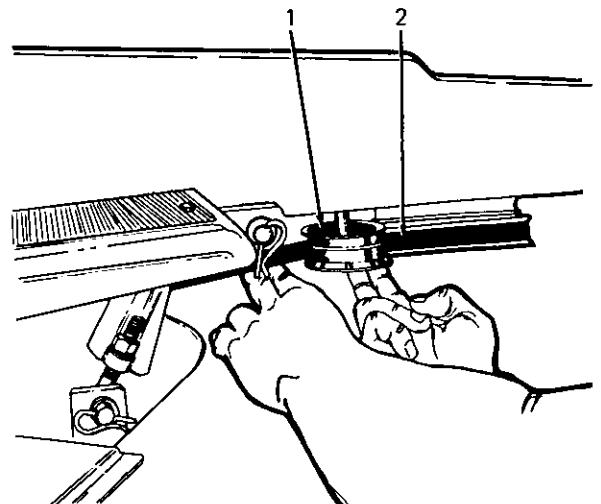

Figure 52.

1. Idler Pulley
2. Drive Belt

**NOTE**

In all cases the rear deck hangers should be attached to the inside of the mower support hangers on the tractor as shown in Figure 50. Figure 52 illustrates the correct deck connections to front and rear deck hangers. Ensure that front and rear deck hangers are installed onto deck as shown in Figure 52.

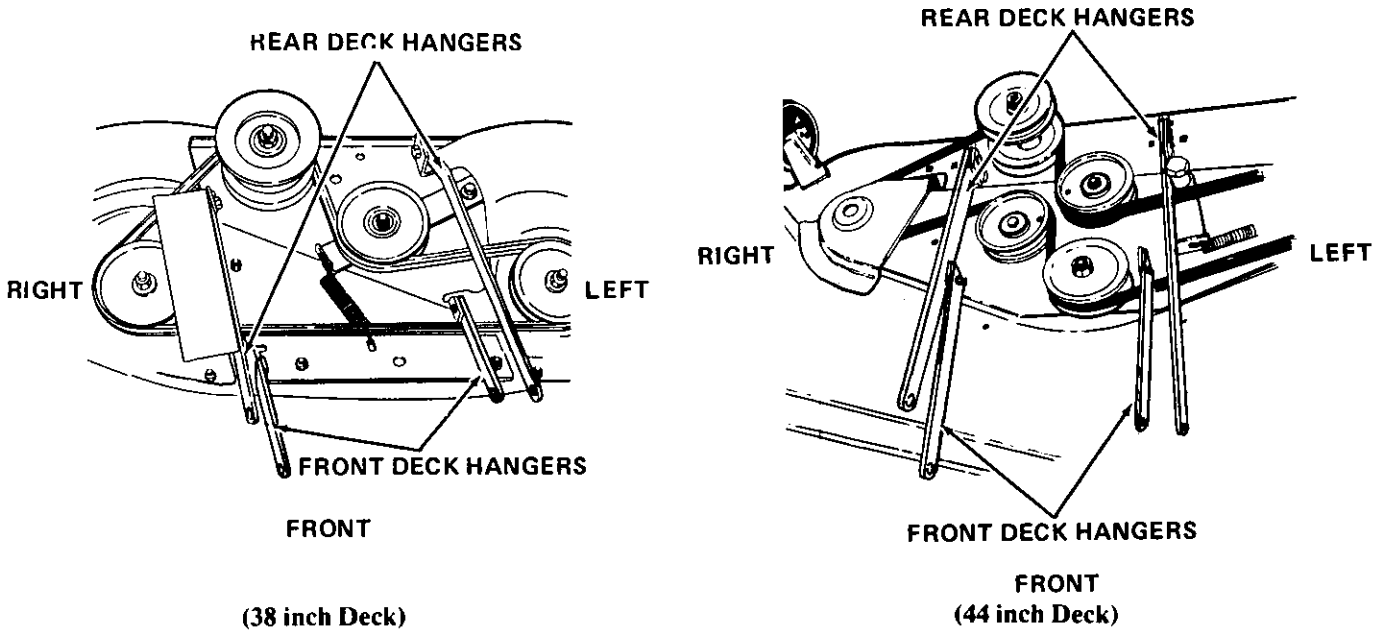

Figure 52

## MAINTENANCE CHART

Operation to be performed	Before each use	10 hours or once a month	30 hours three times a season	50 hours	100 hours or yearly	Before storage
Clean Grille (front & backside) & engine inlet air screen		More often under dirty conditions X				
Check engine oil level	X					
Fill fuel tank	X					
Cylinder head cleaning	Leaded Fuel – 100 - 200 hours Unleaded Fuel – 200 - 300 hours					
Change engine oil	After first 5 hours		More often under dirty conditions X			
Check battery electrolyte level		X				
Grease front axle pivot bolt		X		X		
Lubricate steering knuckles (2) and steering arm		X				
Retorque rear and front wheel bolts		After first 10 hours X			X	
Lubricate brake shaft				X		
Check transmission oil level					X	
Cleaning cooling fins & external surfaces				X		
Service air cleaner					More often under dirty conditions	
Check spark plugs					X	X
Lubricate speed control linkage cam plates (1220 Tractor)					X	
Check and regrease front wheel bearings				X		X
Drain fuel						X
Pivot bar adjustment bolts				X		
Lubricate clutch shaft (1215 Tractor Only)			X			
Movable idler bracket				X		
Steering box				X		
Deck spindles					X	

# TROUBLE SHOOTING

## POSSIBLE CAUSE

## POSSIBLE REMEDY

### HARD TO START

No gasoline in fuel tank or carburetor . . . . .	Fill the tank with gasoline; open the fuel shut-off valve. Check the fuel line and carburetor.
Fuel line or carburetor clogged . . . . .	Clean the fuel line and carburetor with commercial carburetor cleaner.
Water in gasoline . . . . .	Drain the fuel tank and carburetor. Use new fuel and dry the spark plug.
Choked improperly. Flooded engine . . . . .	Follow the starting instructions.
Defective ignition or loose wiring . . . . .	Check the wiring, spark plug, or fuse.
Defective battery . . . . .	Check and service. Refer to "BATTERY."
Spark plug dirty or improper gap . . . . .	Clean, adjust the gap to .025-inch or replace the plug.

### ENGINE OPERATES IRREGULARLY OR KNOCKS

Engine incorrectly timed . . . . .	*
Spark plug dirty; wrong gap or wrong type . . . . .	Clean, reset the gap, or replace.
Poor or weak spark . . . . .	Check the spark plug, and wiring.*
Carburetor setting incorrect . . . . .	Adjust. Refer to "ADJUSTMENTS".*
Poor grade fuel or water in fuel . . . . .	Drain and use a good grade of clean fuel.
Engine overheating . . . . .	Refer to "MAINTENANCE."
Engine valves at fault . . . . .	*
Engine smokes . . . . .	Adjust the carburetor.*
Oil level will rise due to gasoline in crankcase . . . . .	Refer to "OPERATING IN COLD WEATHER."
Air filter will become oil and fuel soaked . . . . .	Refer to "OPERATING IN COLD WEATHER."
Engine leaks oil . . . . .	Refer to "OPERATING IN COLD WEATHER."
Misfiring . . . . .	Refer to "OPERATING IN COLD WEATHER."
Other engine problems . . . . .	*
Excessive oil in air cleaner . . . . .	Be sure that oil dipstick is fully seated and all excess oil is squeezed out of pre-cleaner foam element.

### LACK OF POWER

Air cleaner clogged . . . . .	Service the air cleaner element. Refer to "MAINTENANCE."
Engine overload . . . . .	Reduce the load.
Engine overheated . . . . .	Make sure air intake screen, shrouding, engine fins, and grille are free of accumulated dirt and trash. Refer to "MAINTENANCE."
Poor fuel, too rich, or too lean a mixture . . . . .	Refer to "ADJUSTMENTS."
Fuel tank air vent clogged . . . . .	Open the vent in the cap.
Air leakage between carburetor and engine . . . . .	Remove air cleaner. Tighten the carburetor and manifold mounting nuts. Replace as indicated in "MAINTENANCE."

\* See your authorized dealer.



# TROUBLE SHOOTING

## POSSIBLE CAUSE

## POSSIBLE REMEDY

### HARD TO START

Incorrect timing or faulty ignition .....	*
Brake drags .....	Adjust the brake. Refer to "ADJUSTMENTS."
Clutch slipping (1215 Tractor Only) .....	Adjust the free travel of the pedal. Refer to "ADJUSTMENTS".

### ENGINE OVERHEATING

Insufficient cool air, dirty air intake screen, shroud, cooling fins, or dirty grille .....	Keep the air intake area and cooling fins clean; refer to "MAINTENANCE."
Lean carburetor adjustment .....	Readjust; refer to "ADJUSTMENTS."
Oil level incorrect .....	Engine oil level must not be over the "FULL" mark or below the "LOW" mark. Refer to "MAINTENANCE."

\*See your authorized dealer.

# LUBRICATION TABLE

Point of Lubrication	Check at Hours	Change at Hours	Capacity	Anticipated Air Temperature		
				Above +32°F	+32° to 0°F	Below 0°F
Engine crankcase	Check before each use	30	3 pints	<i>Cub Cadet</i> Low Ash Engine Oil S.A.E.	<i>Cub Cadet</i> Low Ash Oil S.A.E. 10W-40 or 10W-30	<i>Cub Cadet</i> Low Ash Engine Oil S.A.E. 5W-20 or 5W-30
Hydrostatic transmission (1220 tractors only)	Check at 100 hours	Add as needed	<i>Cub Cadet</i> Hydraulic Transmission Fluid.			
Steering knuckles & front axle pivot bolt	10		Use 251H EP grease or equivalent No. 2 multi-purpose lithium grease and apply two or three strokes or sufficient grease to flush out old grease and dirt.			
Front wheel bearings	100 or yearly		Remove front wheels and pack bearings with 251H EP grease or equivalent No. 2 multi-purpose lithium grease and reinstall wheels.			
Steering box	50		Two strokes of the lubricator using 251H EP grease or equivalent No. 2 multi-purpose lithium grease.			
Deck spindles	100 or yearly		Two strokes of the lubricator using 251H EP grease or equivalent No. 2 multi-purpose lithium grease.			

# LUBRICATION GUIDE

The life of any machine depends upon the care it is given. Proper lubrication is a very important part of that care.

Be certain that all lubrication fittings are assembled in place, using the lubrication illustrations as a guide.

Always lubricate the tractor thoroughly before taking it to the field. Use a pressure lubricating gun.

Be sure all fittings are free from dirt and paint so the lubricant is certain to enter the bearing.

Always force the lubricant through the full length of each bearing until it emerges at the end, carrying with it the worn lubricant and any dirt that may have entered the bearing.

Miscellaneous working parts not provided with lubrication fittings should be oiled daily with a good grade of lubricating oil.

Lubricant is cheap. Use plenty of it. Worn parts can be expensive to replace.

Keep your supply of lubricating oil and grease stored in clean containers, and covered to protect from dust and dirt.

Keep the lubricating gun nozzle clean and wipe dirt from grease fittings before lubricating.

The symbols in the illustration indicate the method of application and the hourly intervals to apply the lubricant.



Use a pressure lubricating gun and apply 251H EP grease (or equivalent No. 2 multi-purpose lithium grease) sufficient to flush out the old grease and dirt. Lubricate at hourly intervals indicated on symbols.

Dipstick, use to check engine oil before each use.

## LUBRICATION GUIDE

### —BEFORE EACH USE

1. Engine filler cap and dipstick

Check the oil (with the engine stopped) and add sufficient new oil to bring it to the "FULL" mark on the dipstick. Do not overfill. Do not operate the engine if the oil level is below the "LOW" mark on the dipstick.

### —AFTER EVERY 10 HOURS OF OPERATION

2. Steering knuckles (2)  
(Both sides)
3. Front axle pivot bolt  
(Right side)

Use 251H EP grease or equivalent No. 2 multi-purpose lithium grease and apply sufficient grease to flush out old grease and dirt.

Use 251H EP grease or equivalent No. 2 multi-purpose lithium grease and apply sufficient grease to flush out old grease and dirt.

**NOTE:** It may be necessary to rotate the front axle to reach the grease fitting.

### —AFTER EVERY 30 HOURS OF OPERATION

4. Engine oil drain plug

While the engine oil is warm, remove the drain plug and drain all of the oil from the crankcase. Replace the drain plug. Refer to "MAINTENANCE" "FILLING THE CRANKCASE" for proper oil filling procedure. Refer to "LUBRICATION TABLE" for the proper quantity and viscosity to use.

### —AFTER EVERY 50 HOURS OF OPERATION

5. Steering box

Use 251H EP grease or equivalent No. 2 multi-purpose lithium grease and apply sufficient grease to flush out old grease and dirt.

### —EVERY 100 HOURS OF OPERATION

6. Movable idler bracket
7. Deck spindles

Use 251H EP grease or equivalent No. 2 multi-purpose lithium grease and apply sufficient grease to flush out old grease and dirt.

Use 251H EP grease or equivalent No. 2 multi-purpose lithium grease and apply sufficient grease to flush out old grease and dirt.

### Speed Control Linkage

8. Cam plates  
(1220 Tractor)

Once a year, apply a small amount of 251H EP grease or equivalent No. 2 multi-purpose lithium grease in the slots.

### Miscellaneous

- Brake pedal-shaft

Lubricate the brake pedal shaft and linkage with eight or ten drops of engine oil.

LUBRICATION GUIDE  
MODEL 1215

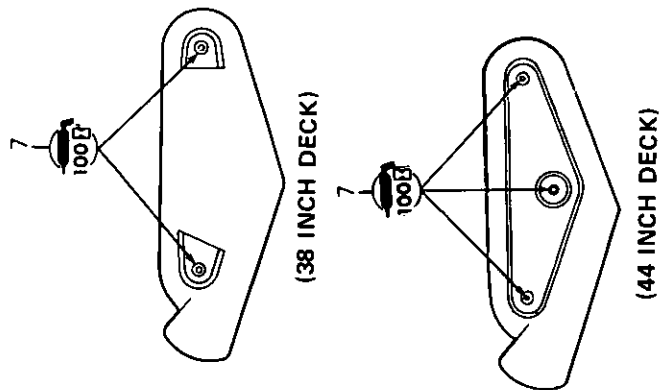
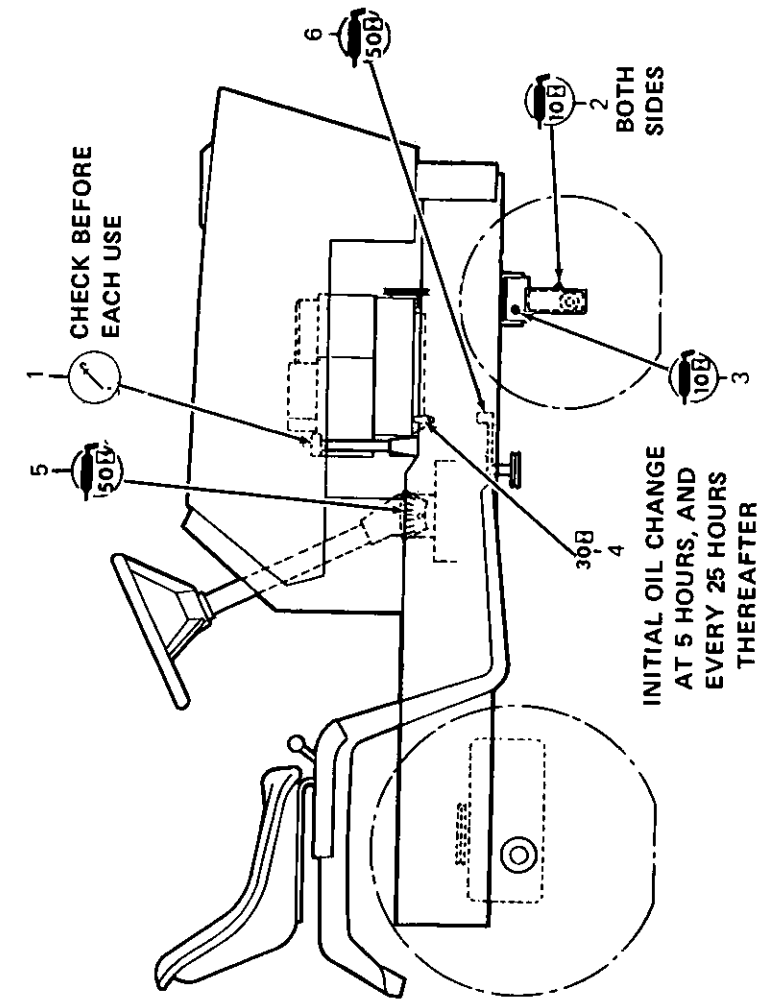

LUBRICATION GUIDE  
MODEL 1220

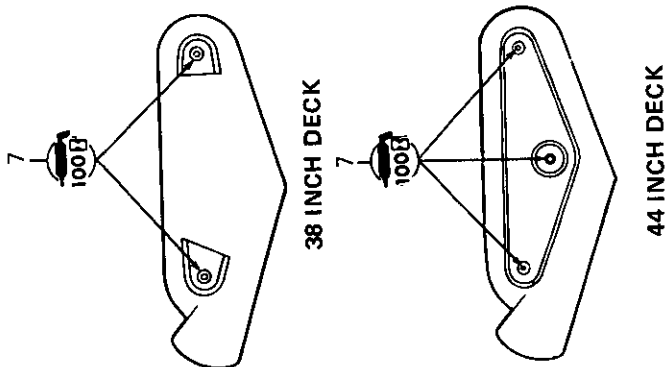
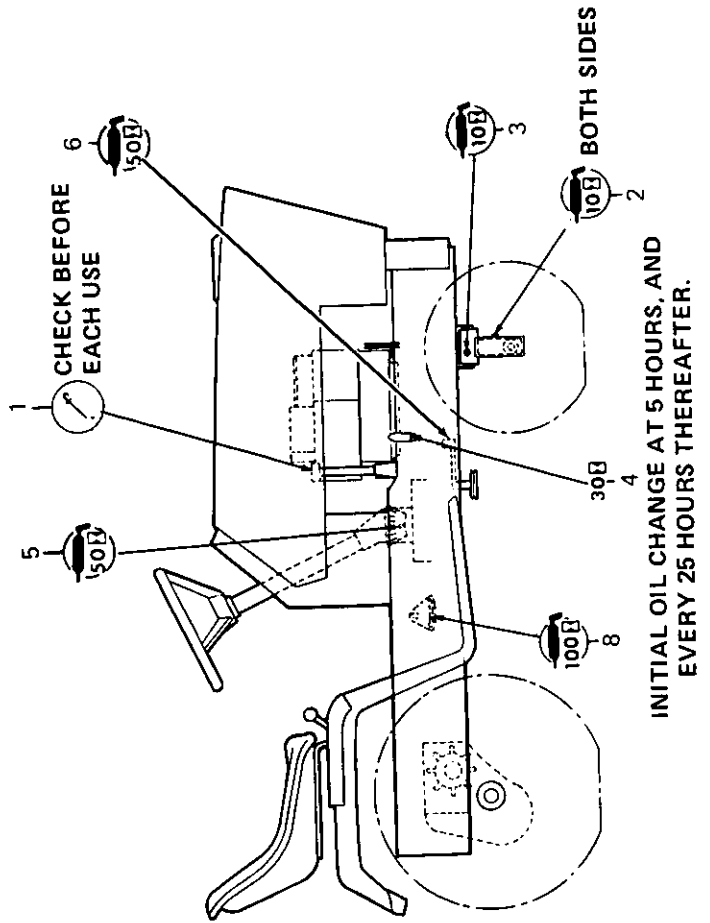

# SPECIFICATIONS

	1215	1220
<b>CAPACITIES</b>		
Fuel Tank .....		3 gals.
Crankcase .....		3 pints
Transmission Hydrostatic .....		1-1/2 pints
Transaxle .....		2-3/4 pints
<b>TRANSMISSION GEARS</b>		
Speed: Forward .....	5 forward speeds and 1 reverse	
Reverse .....	0 to 5.5 mph	
	0 to 2.35 mph	
<b>HYDROSTATIC DRIVE</b>		
Speed: Forward .....		0 to 5.5 mph
Reverse .....		0 to 2.35 mph
<b>ENGINE</b>		
Make and model .....	Briggs and Stratton	
(electric starting) .....	12 HP	
Cylinders .....	1	
Bore .....	3.44 in.	
Stroke .....	3.06 in.	
Displacement (cubic inches) .....	28.40	
Engine Speed	(governed)	
Low Speed .....	1750 RPM	
High idle speed (no load) .....	3400 RPM +/-100	
Ignition .....	Battery	
Spark plug gap (Champion RCJ-8 or equivalent) .....	.030 in. gap.	
<b>ELECTRICAL SYSTEM</b>		
System voltage .....	12 volt neg. ground	
Battery .....	1 HPRLU	
Alternator .....	16 amp	
Fuse (cartridge type) .....	20 amp slow blow	
Headlights (bulb) .....	GE 12 volt 1156	
<b>BRAKES</b> .....	Single disc, external	
<b>CLUTCH</b> .....	V-belt	
<b>TIRE SIZES</b>		
Front .....	15 x 6-6	
Rear .....	20 x 10-8	
<b>GENERAL</b>		
Wheelbase .....	45.0 in.	
Length, over-all .....	68.50 in.	
Turning radius .....	29.00 in.	
Type cutter bar .....	Suction Lift	
Width of cut .....	38 or 44 inches	
Adjustable cutting height (approx) .....	1-1/2 to 4-1/2 inches	
Mower drive .....	V-belt with electric clutch	

Specifications are subject to change without notice.