

MAI

Dimensions
3.0m
5")
excluding Deck

PGC Capacity
390 litres

Transmission

Tuff Torq Heavy Duty Hydrostatic K62,
infinitely variable speed control with
Diff lock. Sealed for life lubrication.

R.
0.4
* P

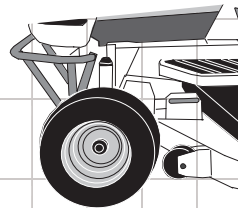
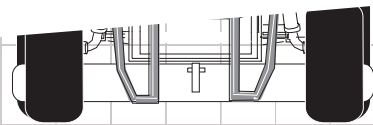
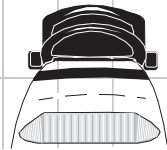

Countax Limited, Countax House, Great Haseley, O
Tel: (01844) 278800 Fax: (01844) 2787
Email: email@countax.com Website:www.co

COUNTA

All figures are approximate. We reserve the right to change specification and price
© copyright 2002 Countax Limited

Safety Instructions

Notes:

CERTIFICATE OF CONFORMITY

EC Declaration of Conformity

I, the undersigned A. Bennett of Countax Limited Great Haseley Oxford OX44 7PF declare that the Lawnmowers described below :

Model	A20/ 50
Power (kW)	14.9
Maximum blade rotation (rpm)	3100
Engine Manufacturer	Briggs & Stratton
Engine Type	4 stroke Petrol
Guaranteed Maximum Sound Power level	105dB(A)
Max. Vibration m/s_ (Hands)	2.05
Max. Vibration m/s_ (Seat)	0.53
Cutting Device	Cutter
Cutting Device Width	127cm

Complies to the provision of the directive 89/392/EEC amended by 98/37/EC and the regulations transposing it into national law.
Complies with the provisions of "noise emission in the environment by equipment for use outdoors" directive 2000/14/CE and the regulations transposing it into national law
Complies with the provisions of "electromagnetic compatibility" 89/336/EEC directives and the regulations transposing it into national law.
Tested at : Oxford, England
Signed:



A.Bennett 1/2/02

Contents Summary:

Safety Instructions	-Page 2 and 3
Controls and Indicators - Dashboard	-Page 4
Controls	-Page 5 and 6
Mulch Deck	-Page 7
Rear Discharge Deck	-Page 8
Cutter Deck Removal	-Page 9
Cutter Deck - Check List	-Page 10
Deck Levels - Front to Back	-Page 11
Cutter Levelling Side to Side	-Page 12
Cutter - Drive Belt	-Page 13
Powered Collector	-Page 14
Collector Adjustments	-Page 15
Collector Drive Belts	-Page 16
Collector Brush	-Page 17
Tyres - Check List	-Page 18
Tyres - Removal of Wheels	-Page 19
Engine - Oil	-Page 20
Engine - General Maintenance	-Page 21
Electrical	-Page 22
A20/50 Wiring Diagram	-Page 23

READ THE INSTRUCTION MANUAL BEFORE USING THE GARDEN TRACTOR AND ENSURE THE OPERATORS STUDY IT FOR THEIR OWN SAFETY.

THE FOLLOWING PRECAUTIONS ARE OUTLINED TO HELP PREVENT ACCIDENTS. A CAREFUL OPERATOR WHO USES COMMON SENSE IS THE SAFEST OPERATOR.

THESE SAFETY PRECAUTIONS ARE IN ADDITION TO THOSE IN THE INSTRUCTION MANUAL.

CAUTION

THIS SYMBOL MEANS BE ALERT

PREPARATION

MANDATORY SAFETY INSTRUCTIONS FOR THE OPERATION OF GARDEN TRACTORS

TRAINING

1. Read the instructions carefully. Be familiar with the controls and the use of equipment.
2. Never allow children or people unfamiliar with these instructions to use the mower.
3. Never mow while people, especially children, or pets are nearby.
4. The operator or user is responsible for accidents or hazards occurring to other people or their property.
5. Do not carry passengers.
6. All drivers should seek to obtain professional and practical instruction. Such instruction should emphasise:
 - The need for care and concentration when working with this machine.
 - Control of a Tractor sliding on a slope will not be regained by the application of the brake.

The main reasons for loss of control are:

- Insufficient wheel grip.
- Driving too fast.
- Inadequate braking.
- Incorrect load distribution.

1. Check that the machine complies with all applicable regulations, including those in force when used on the public highway.
2. When mowing always wear substantial footwear and long trousers. Do not operate when barefoot or with open toe sandals.
3. Warning – petrol is highly flammable:
 - Store fuel in containers specifically designed for this purpose.
 - Refuel outdoors only and do not smoke when refuelling.
 - Add fuel before starting the engine. Never remove the cap from the fuel tank or add petrol while engine is running or when engine is hot.
 - If petrol is spilled, do not attempt to start engine but move the machine away from area of spillage and avoid creating a source of ignition until petrol vapours have dissipated.
 - Replace the fuel tank cap securely.

Notes:

Safety Instructions

4. Replace faulty silencers.
5. Before using always inspect to see that the blades, bolts and cutter assembly are not worn or damaged.
6. Check the condition of the tyres and ensure that they are inflated to the correct pressure (refer to the specifications). This is particularly important if the machine is to be taken on the public highway.
7. Check the mower is in good working order, paying particular attention to brakes and steering.
8. Check that all linkages, connections, and pivot nuts are secure and that the wheel nuts are torqued correctly.

OPERATION

1. Do not operate the engine in a confined space where dangerous fumes can collect.
2. Mow only in daylight or in good artificial light.
3. Before starting the engine, disengage blade and attachment drives and shift into neutral.
4. Take care on slopes of more than 10° incline or decline (Maximum safe operation is at 15°).
5. Remember that there is no such thing as a 'safe' slope. Travel on grass slopes requires particular care to guard against overturning:
 - Do not stop or start suddenly when going up or downhill.
 - Engage clutch slowly. Always keep machine in gear, especially when travelling downhill.
 - Machine speed should be kept low on slopes and in tight turns.
 - Stay alert for humps and hollows and other hidden hazards.
 - Avoid mowing across the face of the slope.
6. Watch out for traffic when crossing or near roadways.
7. Stop the blades rotating before crossing surfaces other than grass.
8. When using the machine, never direct discharge of material toward bystanders or allow anyone near the machine while in operation.
9. Never operate the mower with defective guards, shields or without safety protective devices in place and in good working order.
10. Do not change governor settings to increase the revs of the engine. Operating an engine at excessive speed increases the risk of injury.
11. Before leaving the operators position:
 - Disengage the drive to the cutter blades and attachments and lower the attachments.
 - Change to neutral and set the parking brake.
 - Stop the engine and remove the ignition key.
12. Disengage drive to attachments, stop the engine and disconnect the spark plug lead or remove ignition key before:
 - Clearing blockages.
 - Checking, cleaning or working on the mower.
 - Refuelling.
 - Removing the grass catcher.
 - After striking a foreign object. (Inspect the mower for

- damage and make repairs before restarting the Tractor).
 - If the machine starts to vibrate abnormally check immediately and call dealer if necessary.
13. Disengage drive to attachments when transporting or not in use.
 14. Reduce the throttle setting during engine run-out.
 15. Never work on the mower when the engine is running.

MAINTENANCE AND STORAGE

1. Check that all nuts, bolts, and screws are tight to be sure the equipment is in safe working condition.
2. Never store the equipment with petrol in the tank inside a building where fumes may reach open flame or spark.
3. Allow the engine to cool before storing in any enclosure.
4. To reduce the risk of fire keep the engine, silencer and battery compartment free of grass, leaves, petrol or excessive grease.
5. Check the grass catcher frequently for wear and tear or deterioration.
6. Replace worn or damaged parts for safety.
7. If the tank has to be drained, this should be done outdoors.
8. Be careful during adjustments of the machine to prevent entrapment of the fingers between moving blades and fixed parts of the machine.
9. Do not use steam cleaners or high pressure washers directly towards bearings or electrical components (Countax do not recommend the use of these power cleaners).

SUPPLEMENTARY INSTRUCTIONS FOR USE OF COUNTAX A20/50 TRACTOR

1. Use good sense at all times and, to ensure this Tractor is safe and serviceable, fit only original manufacturers' supplied spares.
2. When inspecting the area to be cut, note also the position of any stumps, manhole covers, bumps and depressions and avoid them to prevent damaging the blade.
3. We recommend the use of standard UNLEADED fuel and that you ensure the fuel tank is full before you start the machine.
4. Always disconnect both battery terminals before attempting any work in the engine compartment.
5. Do not leave the Tractor unattended and running.
6. Do not put hands near moving belts or the Power Take-Off pulley while it is rotating.

Controls and Indicators - Dashboard

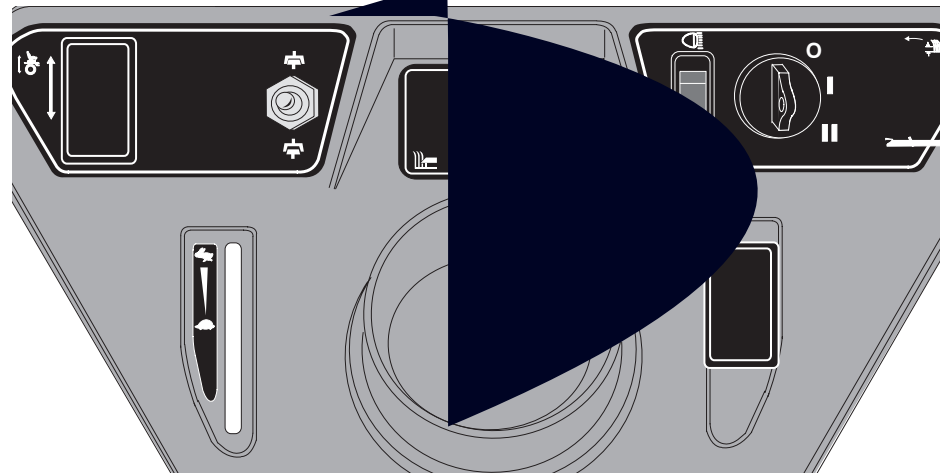

Notes

IGNITION

The 'Key Start' controls both the ignition and the starter. Insert the key and turn to the 1st position, the dashlights will come on (check that all is ready to start), then turn further to activate the starter. Release when engine starts. To stop, turn the key to the left (having first switched off both cutter and PTO).

IT IS ALWAYS GOOD PRACTICE TO REMOVE THE KEY AND KEEP IT SAFE.

As with a car, it is important to prevent unauthorised use by children who could injure themselves.

CHOKE

An independent choke is fitted to the A20/50. This choke should be used in combination with a fast throttle setting to start a cold engine. Cancel as soon as possible. Do not use choke on a warm engine.

CUTER ON/OFF SWITCH

The cutter switch controls the Electromagnetic Blade Clutch. It works like a light switch (but in reverse) – **UP** for **ON** and **DOWN** for **OFF**. Although it always returns to the central position and the cutter deck will automatically be turned off when the engine is switched off, it is not good practice to rely on this. The cutter deck should always be switched **OFF** as soon as you have finished cutting and certainly **BEFORE** stopping the engine or getting off the Tractor.

THROTTLE

The lever is pushed forward and up for **FAST**, back and down for **SLOW**. A cold engine is started on the **FAST** setting with choke, a warm one on the **FAST** setting. The Choke setting should be cancelled as soon as possible and the engine operated on **FAST** setting at all times.

HEADLIGHT SWITCH

The headlights are turned **ON** by switching the rocker switch on. The headlights will not operate when the ignition is **OFF**. Turn the headlights **OFF** before starting or stopping.

HE Wiring Diagram

Controls - Forward/Reverse

COUNTAX HE WIRING ACTUATOR POWERED ROTARY DECK SWITCH

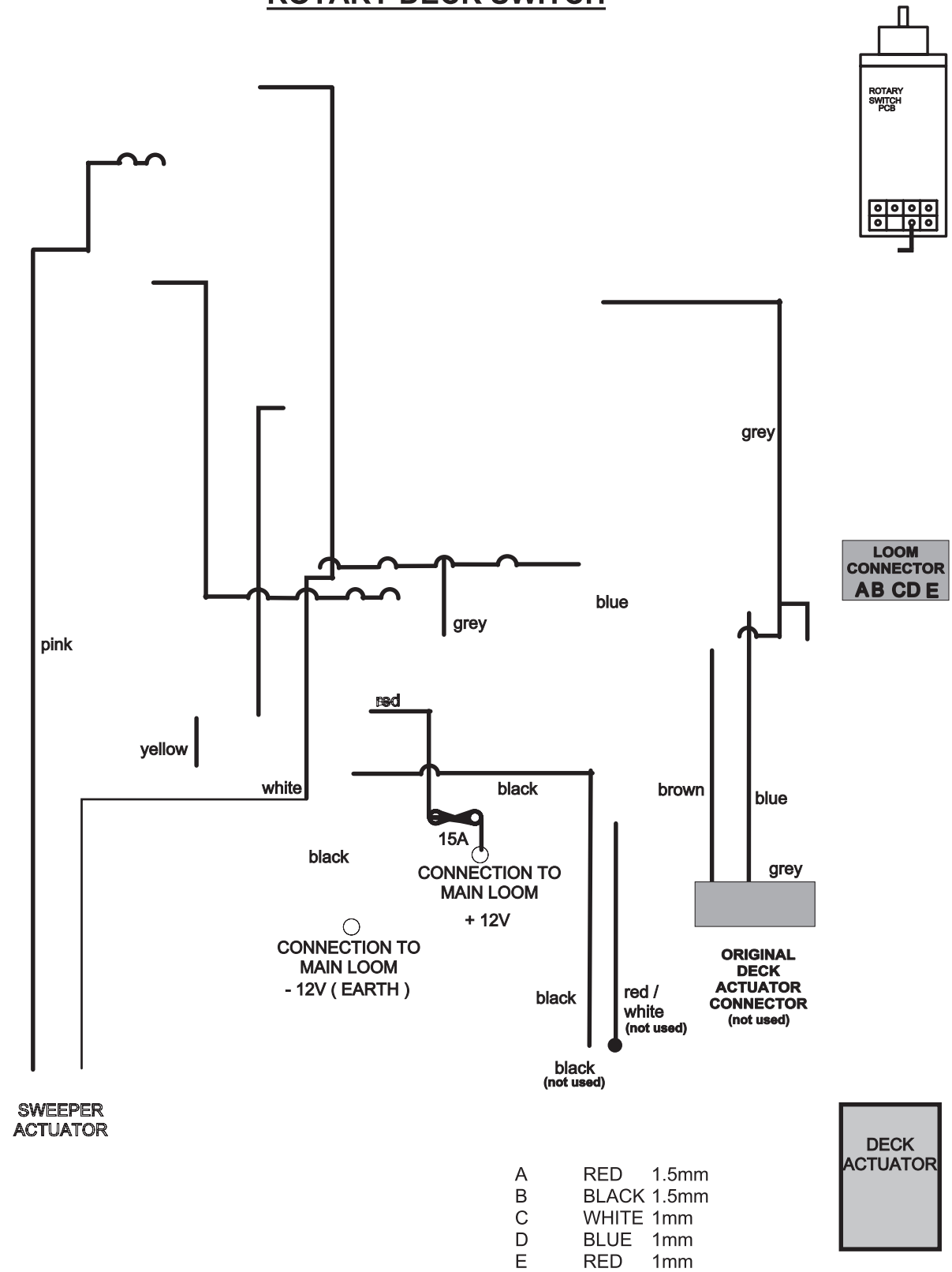

Controls - Levers

POWER-TAKEOFF (PTO)

Push the lever down and to the left to engage the pto, to disengage push the lever down and lift to the right.

ELECTRIC LIFTS

The cutting height is adjusted by rotating the 'dial-a-height' switch anti-clockwise to lower the deck and clockwise to raise the deck. The indicated heights (1-lowest to 10-highest) are shown for guidance purposes only. To get the best from this refinement use it to continuously adjust cutting height to suit ground and grass conditions. Do not make downward adjustments on the move until you are familiar with this height control, to avoid scalping.

Raising the Auxiliary Lift is achieved by pressing the switch (B) to the left of the dashboard – UP to raise, DOWN to lower (fig 3).

PGC NET EMPTY SWITCH

A third switch is fitted to those Tractors with a Powered Grass Collector. This switch empties the collector net via an electric actuator mechanism that lifts the grass box and pushes out the bottom pan, fully emptying the collector contents. Press the switch UP to open and DOWN to close the net (fig 5).

SEAT ADJUSTMENT

The seat on the A20/50 is adjustable forwards and rearwards to suit the operator. Simply lift the seat latch at the front of the seat (fig 4) and slide the seat forwards or backwards to suit. Always ensure the seat is latched back into position before driving off.

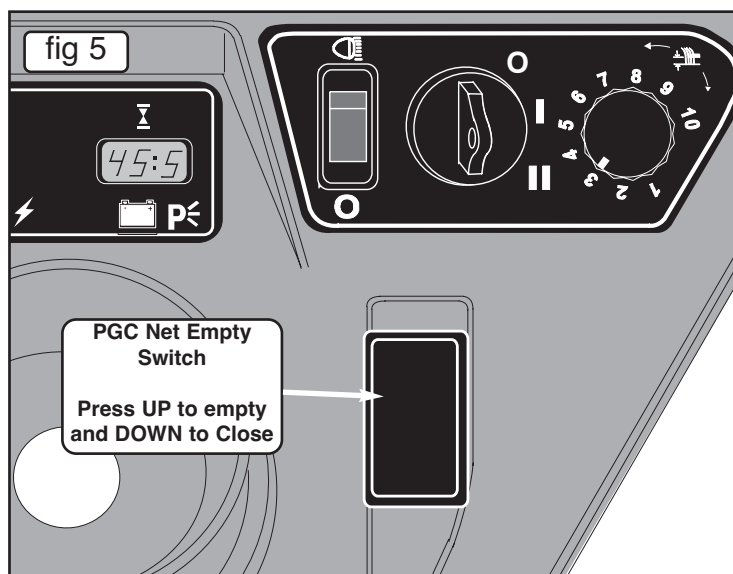
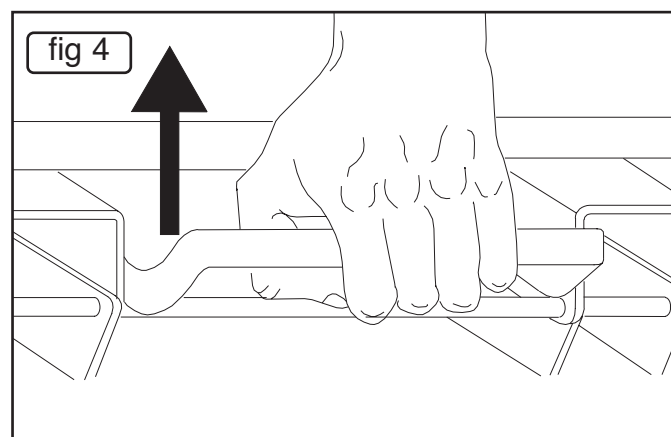
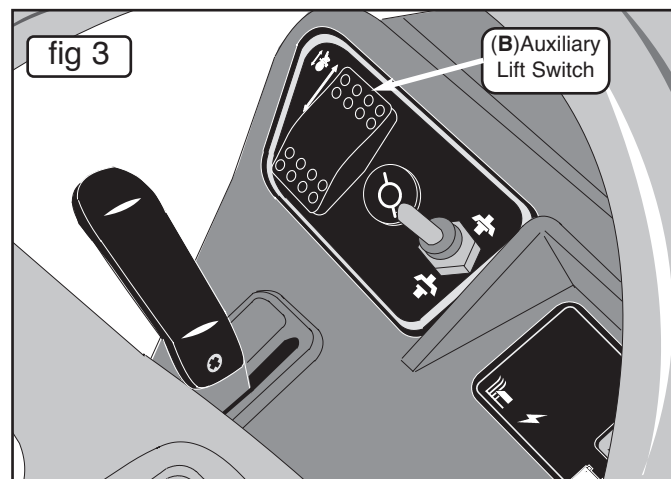
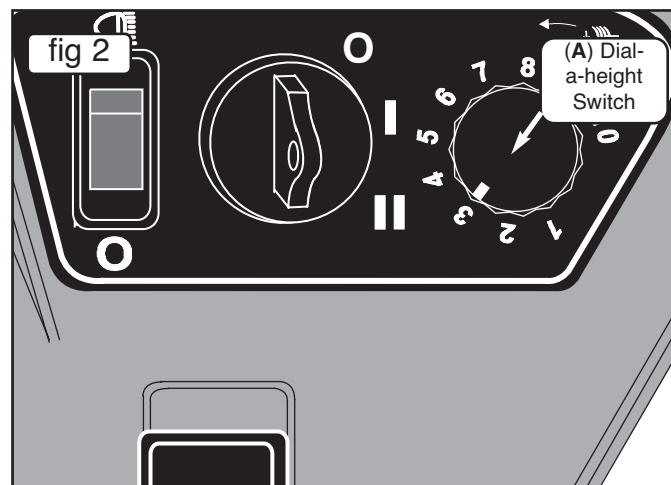
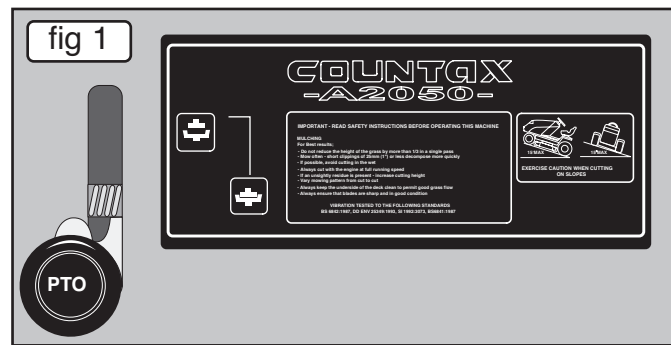

Wiring Diagram

TRACTOR WIRING DIAGRAM

- 1 White
- 2 Red / Blue
- 3 Brown
- 4 Grey
- 5 Red / Blue
- 6 White / Red
- 7 Black
- 8 Purple
- 9 Yellow
- 10 Green
- 11 Orange
- 12 Red / Yellow
- 13 Blue

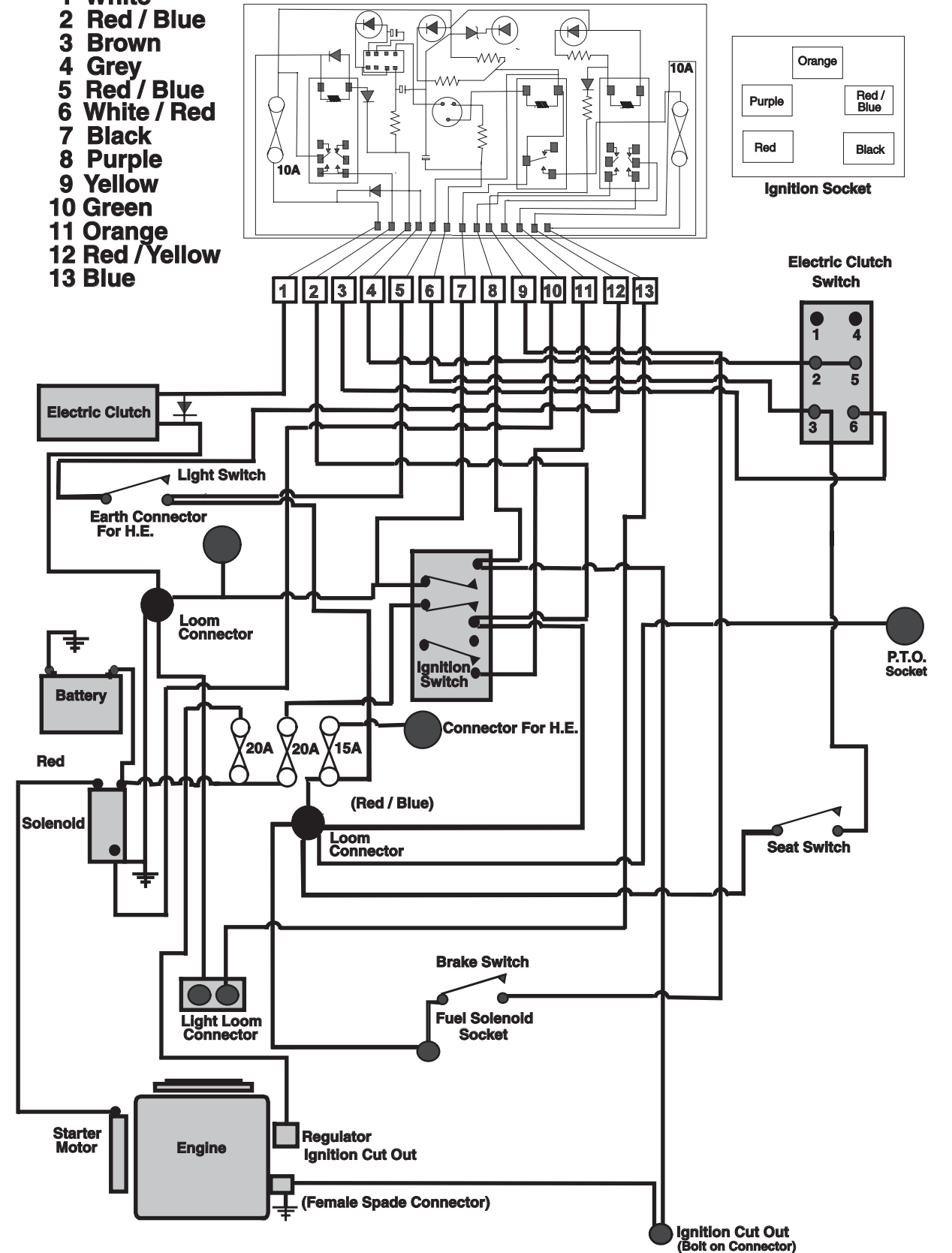

Electrical

There are five 20 Amp fuses on the A20/50 Tractor.

1. 20Amp (**yellow**) for charging circuit.
2. 20Amp (**yellow**), ignition, safety switches.
3. 20Amp (**yellow**) electric lift for Cutter Deck and Auxiliary lift.
4. 20Amp (**yellow**) located left-hand side of the console is for net emptying circuit.

To check - remove fuse and check small window, there should be an unbroken metal strip bridging the gap (fig 4).

Note - If No.2 20Amp fuse blows when the ignition key is turned this means there is a short between the red and blue coloured wire and the body of the Tractor. The usual places to investigate are:

- The electrical PTO and socket.
- Seat switch wires (fig 3).

If fuses blow after these have been checked, call your dealer.

PRINTED CIRCUIT BOARD FUSES

There are 2 10Amp Blade fuses on the circuit board (fig 5) which can be reached by removing the cover (fig 1). These two fuses control the lights and the Electromagnetic Blade Clutch. If the problem is not a fuse and you cannot see any loose connections - call your dealer.

ELECTROMAGNETIC BLADE CLUTCH

If the blade clutch disengages without being switched off these are the possible causes:

- You have got off the seat - the safety switch will disengage the cutter.
- The battery has lost charge and will no longer hold the clutch in operation.
- Fuse blown on Printed Circuit Board - see above.
- Faulty Safety Switch or break in wire - see your dealer.

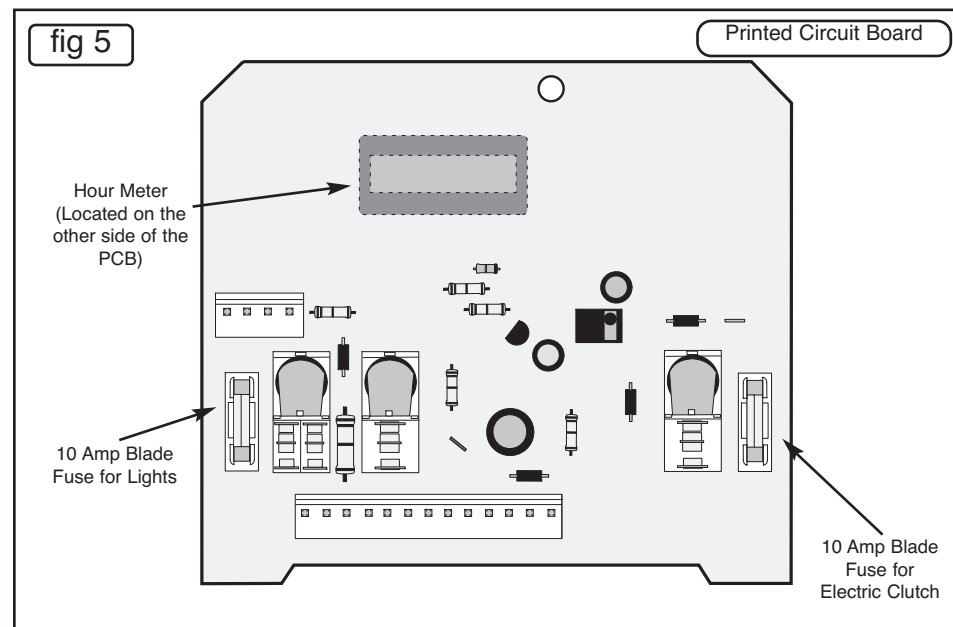
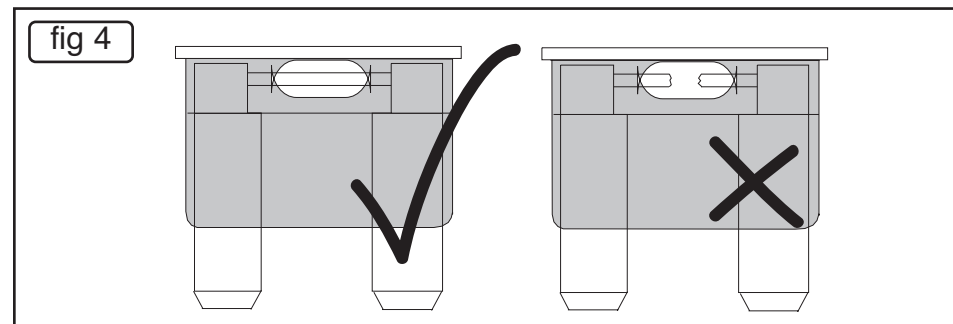
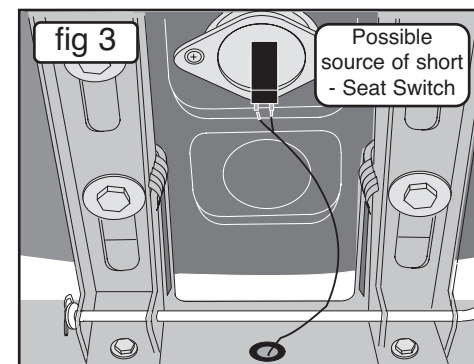
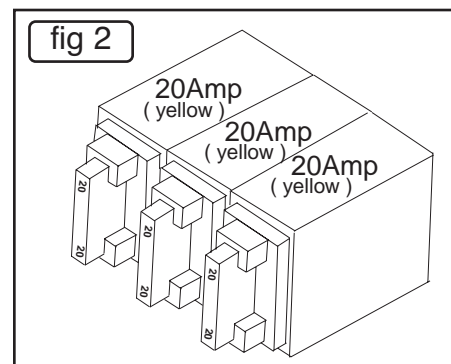
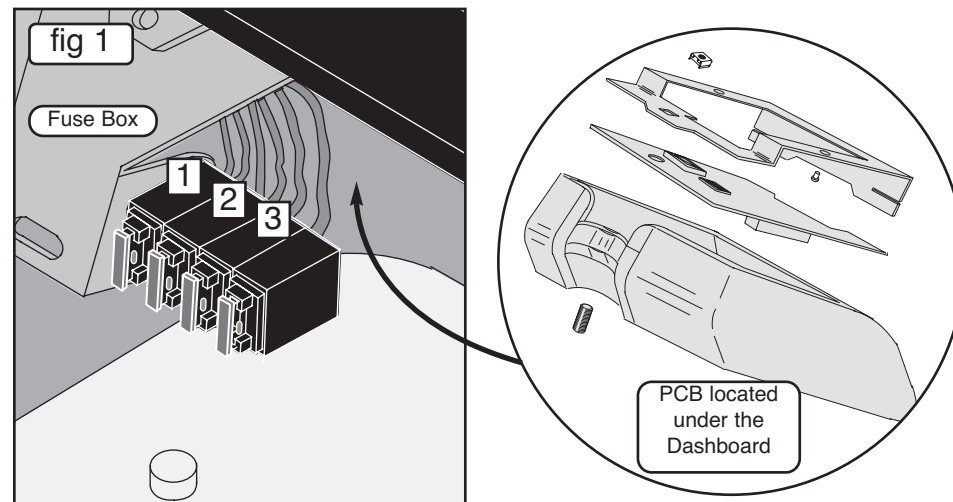

Mulch Deck

MULCH MOWING

Mulching can save time, avoids gathering piles of rotting cuttings and feeds your lawn. It is however necessary to observe certain rules to mulch mow successfully:

- Reduce the height of the grass by no more than 1/3rd its height in each pass. If the grass has grown long make several passes to achieve the cut height you require.
- Always cut with the throttle set to **FAST** – mulching needs the full running speed of the engine.
- Mow often, particularly in Spring and early Summer. Short clippings of 25mm (1") or less decompose more quickly.
- If possible avoid cutting in the wet.
- If an unsightly residue of cuttings is being left – increase the cutting height.
- Vary the mowing pattern from cut to cut.
- Always keep the underside of the cutting deck clean to ensure good grass flow.
- Always check that the blades are sharp and in good condition – but do not attempt to sharpen or replace them yourself. New Countax blades are not expensive and it is good practice to ask your dealer to change them regularly.

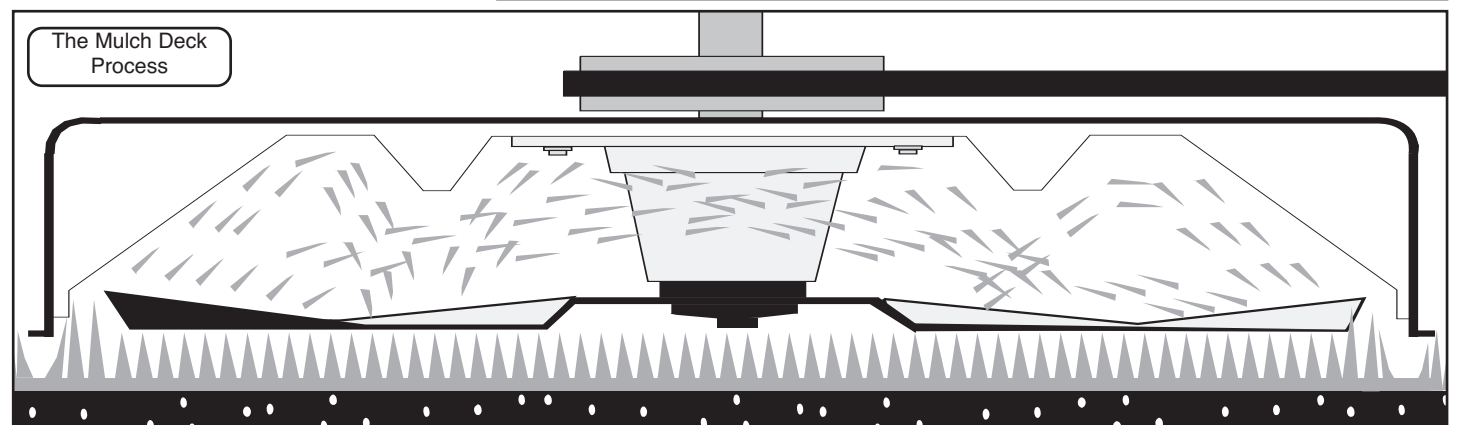
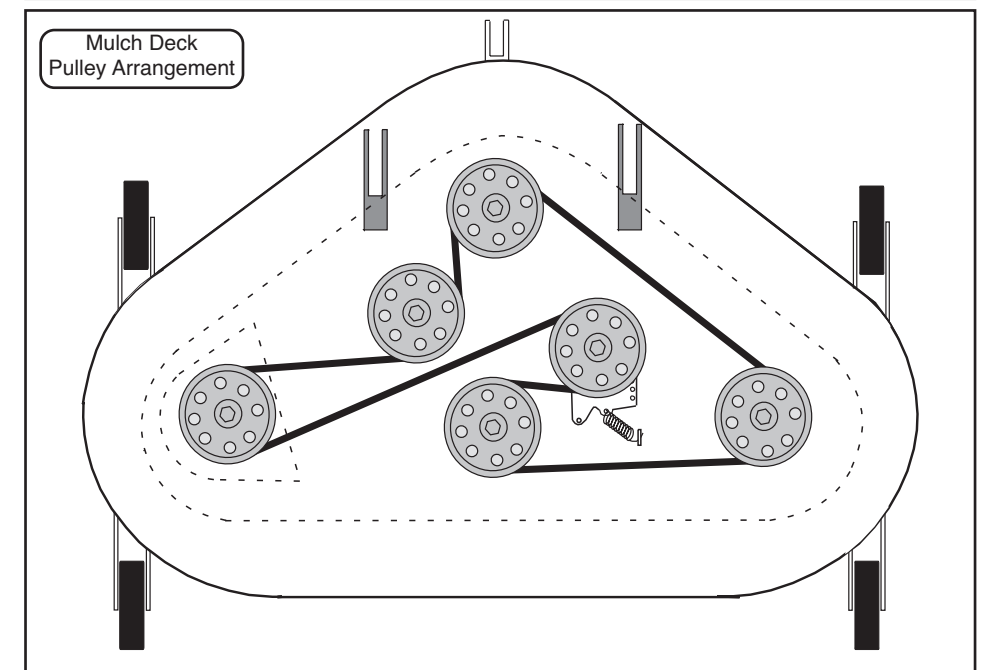
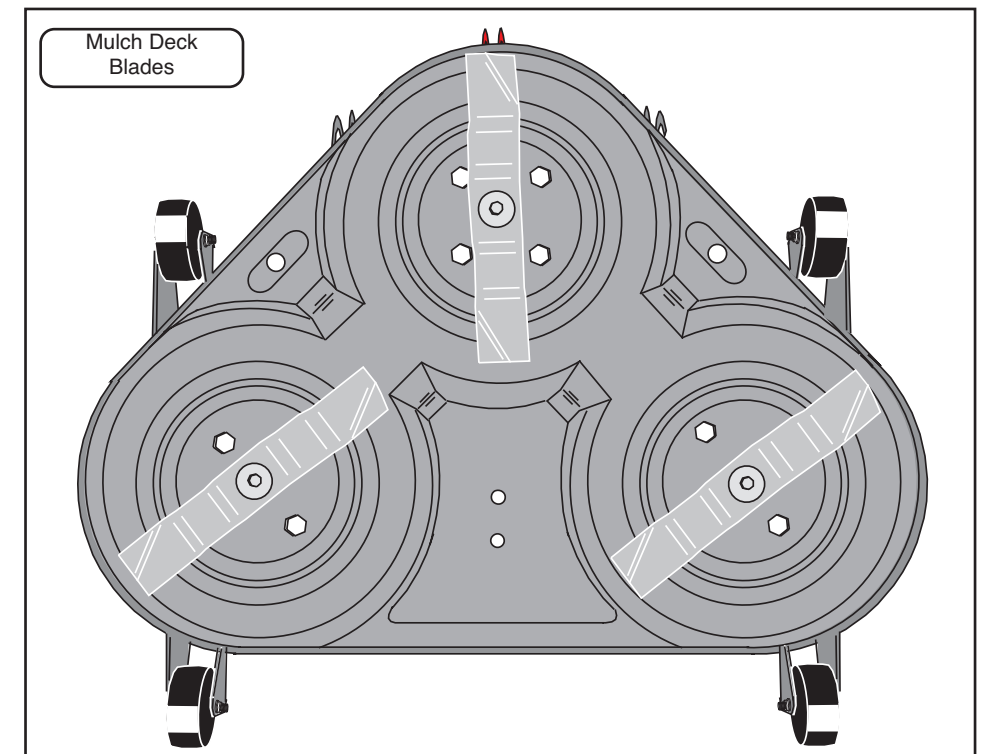

Rear Discharge Deck

Specified Belts and Blades

Engine/Deck Belt - B56 Dayco Super II - Pt No. 22940100 (IBS)

Engine/Deck Belt - B57 Dayco Super II - Pt No. 22871200 (MULCH)

Deck Internal Drive Belt (Mulcher) - BB112 Pt No. 228000900

(Rear Discharge) - Dayco Super II BB155 Pt No. 22950200

Mulcher Blades x3 Pt No. - 216938100

IBS RH Blade Pt No. 169381300

IBS LH Blade Pt No. 169381400

IBS Front Blade Pt No. 1692000

PGC Drive Belt Super II A49 - Pt No. 228001200

PTO Drive Belt - Dayco Super II A92 - Pt No. 22950100

Transmission Drive Belts - A92 Dayco Super II - Pt No. 22950100

N.B. Only use specified Belts and Blades - Never accept a substitute!

Engine - General Maintenance

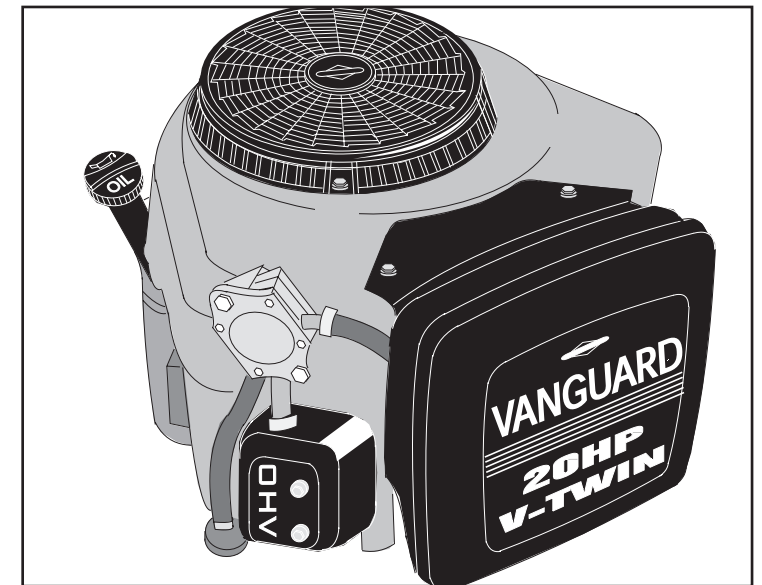
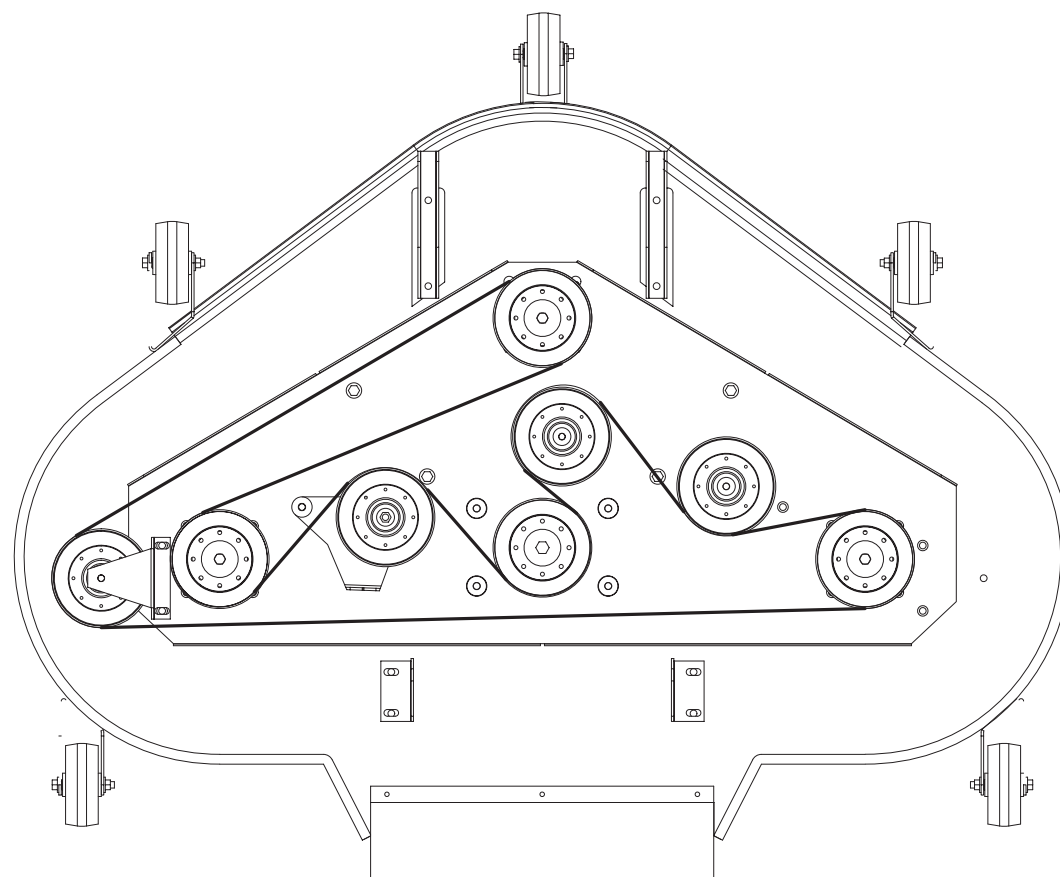

fig 1

Routing for IBS internal deck drive belt



Engine - Oil

OIL DRAINING

NOTE: OIL SHOULD BE CHANGED WITHOUT FAIL AFTER THE FIRST FIVE HOURS OF RUNNING.

The A20/50 Tractor has an oil drain adaptor (fig 1) located on the right hand (off side) of the engine. This is like a bayonet light fitting, which you push in and turn anti-clockwise to release. A short length of clear hose is supplied in the toolkit that fits on this adaptor so that waste oil can be poured into a can or bottle.

BEFORE DRAINING

- * Start up the engine and allow to idle until it is warm (about five minutes).
- * Switch off the engine, lift open the bonnet, and unscrew the oil cap/dipstick.

TO DRAIN

- * Locate the Oil Drain (fig 1).
- * Remove the Yellow Dust Cap.
- * Fit the short length of hose supplied over the nozzle of the adaptor (see fig 2) and direct the other end into a container large enough to take 2 litres of waste oil.
- * Press the adaptor in; turn anti-clockwise to lock (fig 3). Remove hose and store for next use. Replace Yellow Dust Cap.
- * Refill with recommended oil (SAE30 detergent oil classified for service - SG, SF, SE) to engine manufacturer's instruction.

DO NOT OVERFILL

The use of lubricants that are not recommended may lead to excessive wear or damage - and this will NOT be covered by warranty.

ALWAYS READ AND FOLLOW THE ENGINE MANUFACTURER'S INSTRUCTIONS ON ALL MATTERS RELATING TO USE AND MAINTENANCE. OBSERVING THE OIL CHANGE INTERVALS WILL GREATLY ENHANCE THE SERVICE LIFE OF YOUR ENGINE!

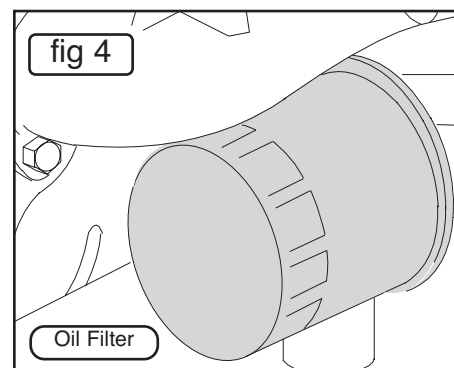

Before carrying out any repair or servicing

Ensure that the Tractor is on a firm level surface.

Apply the handbrake.

Disconnect the battery.

Extinguish all naked flames.

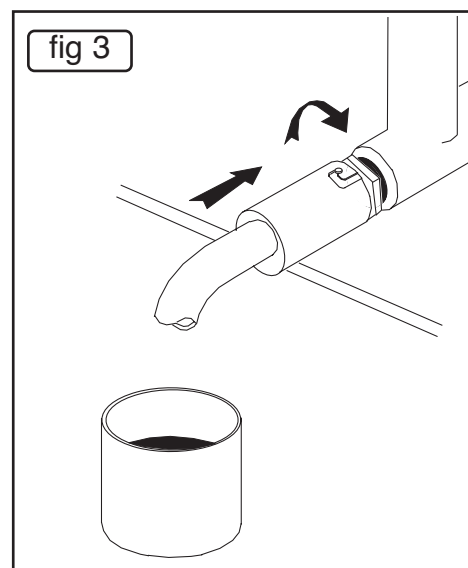
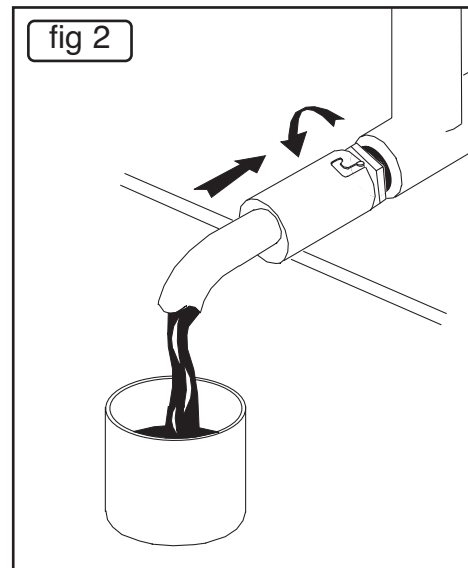
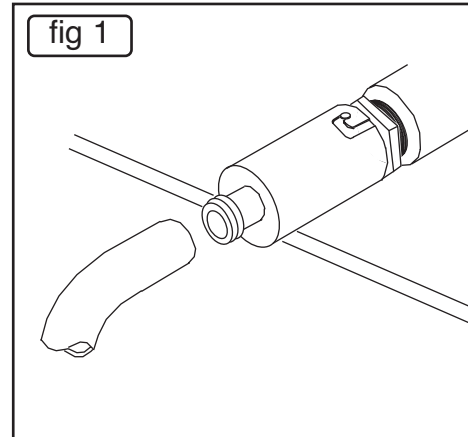

N.B.
The information contained in the following pages is given on the understanding that Countax accepts no responsibility for work carried out by a customer or for any damage thus caused whether or not the service instructions have been misunderstood. To be absolutely sure that your warranty terms are not breached, service work should only be carried out by a Countax dealer.

Cutter Deck Removal (Mulch/Rear Discharge Deck)

The Rear Discharge Deck is used in conjunction with the PGC. It ejects the grass rearwards after cutting for the Powered Grass Collector to collect. Either the Mulch Deck or the Rear Discharge Deck can be fitted to the A20/50 using the following instructions:

REMOVAL OF CUTTER DECK

The cutter deck can be quickly removed for servicing or cleaning or to give greater clearance when driving or towing over uneven ground.

Follow this sequence:

1. Put cutter to lowest position.
2. De-tension the Cutter Drive Belt with the lever under the left (nearside) running board.
3. Remove the 3 securing pins from the front of the deck (fig 3 - A, B and C) by pulling out the spring clips.
4. Remove pin G and remove deck tension bar.
5. Remove fifth anti-scalp wheel (fig 6)
6. Remove the 2 securing pins from the back of the deck (fig 2 - D and E).
7. Slip the Cutter Drive Belt off the Engine Pulley.
8. Slide the deck out.
9. If you are going to use the Tractor without the deck, remove the Securing Bar (F).

WHEN REPLACING THE CUTTER DECK, RE-TENSION THE BELT WITH THE LEVER UNDER THE RUNNING BOARD. Then check the belt tension (see page 13).

TO CLEAN CUTTER DECK

Remove the deck as instructed, stand it on its side and hose off accumulated cuttings. This may be necessary routinely to prevent build-up of cuttings, particularly at the beginning of the season when the grass is lush and wet. Thoroughly wash the underside of the cutter deck as regularly as possible.

ENGINE TO CUTTER DRIVE BELT REPLACEMENT

Follow this sequence:

1. Pull the Belt Tension Lever (page 13 fig 1) forward.
2. Lower the Cutter Deck to the lowest position.
3. Remove the belt from the forward Electric Clutch Pulley - it will slip off.
4. Remove the Cover of the Cutter Deck Pulley Housing - loosen and remove the 1/4" UNF nut and bolt using two 7/16" spanner/sockets - then slide (tap) the cover off.
5. Remove the belt from the Cutter Deck Pulley - you may have to ease it off by rotating the pulley.
6. Now replace with the CORRECT BELT (see previous page) by reversing this procedure, taking care to fit the belt into the 'V' grooves.
7. Pull back the Belt Tension Lever so the belt is tensioned. Now check and adjust belt tension as detailed on page 13.

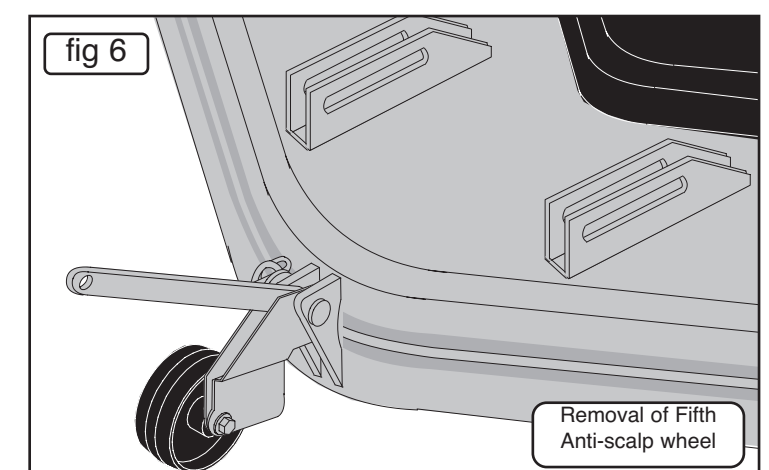
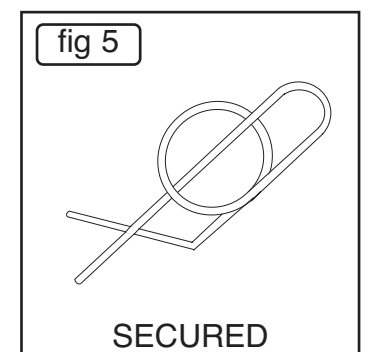
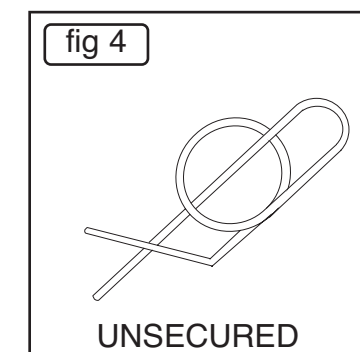
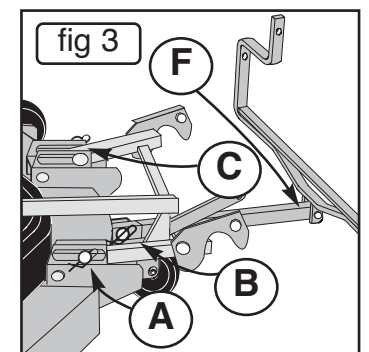
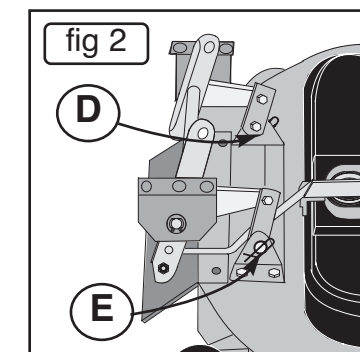
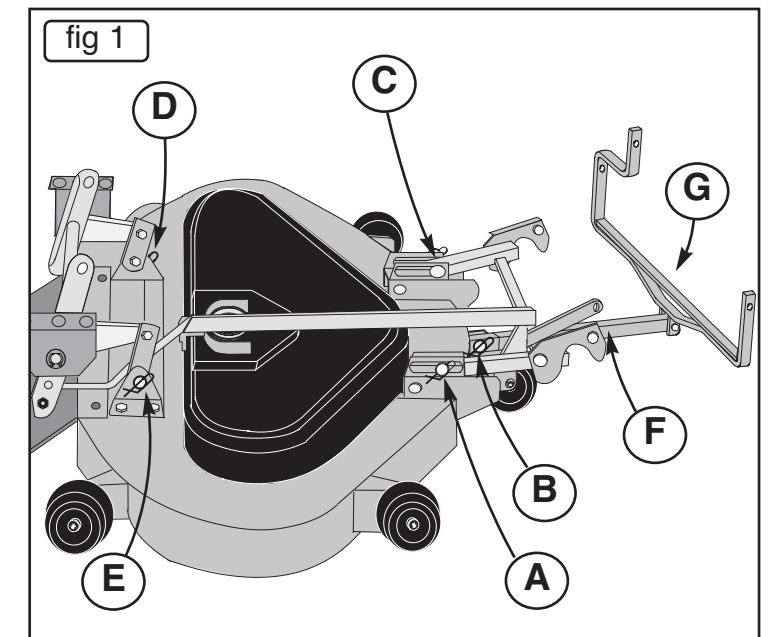

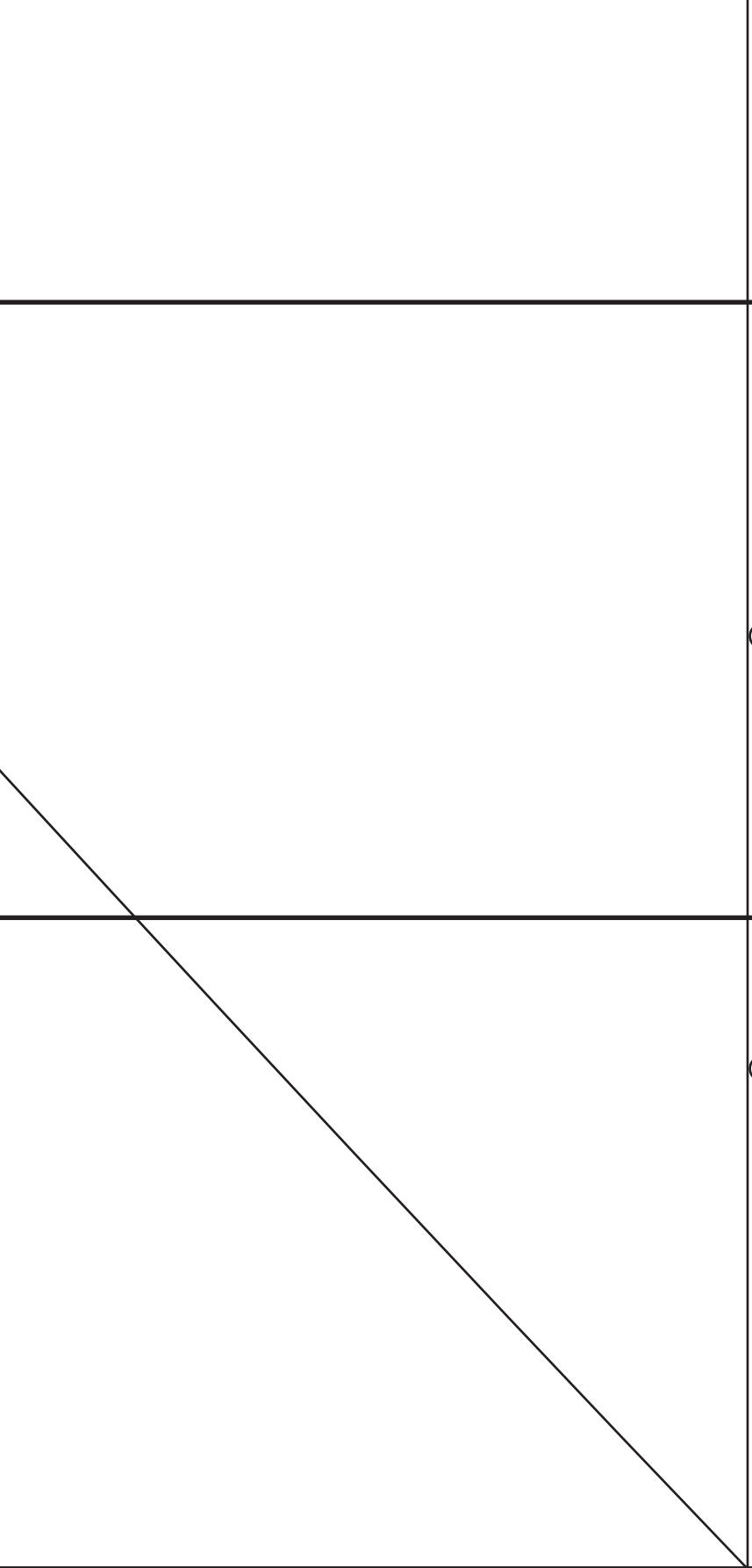

Cutter is not level side to side

Cutter is not level side to side

Cutter is not level front to back (Tipped forward)

Cutter is not level front to back (Tipped back)

Individual cutter blades damaged or bent

W

-
-
-
-
-
-
-

W
w
N

- *
- *
- *
- *
- *
- *
- *

i WARNING

N
J
B
W
R
T
T
S

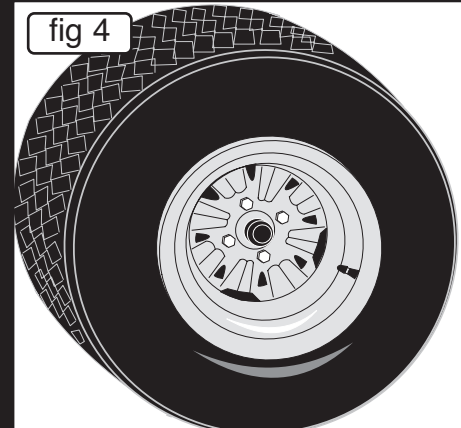
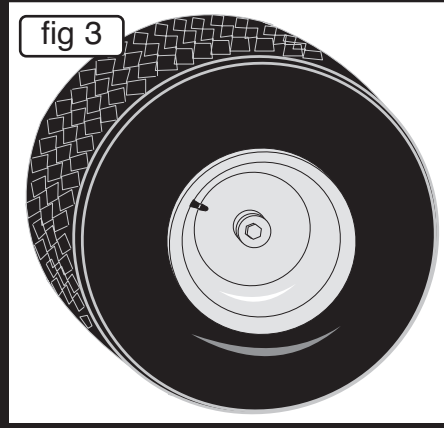
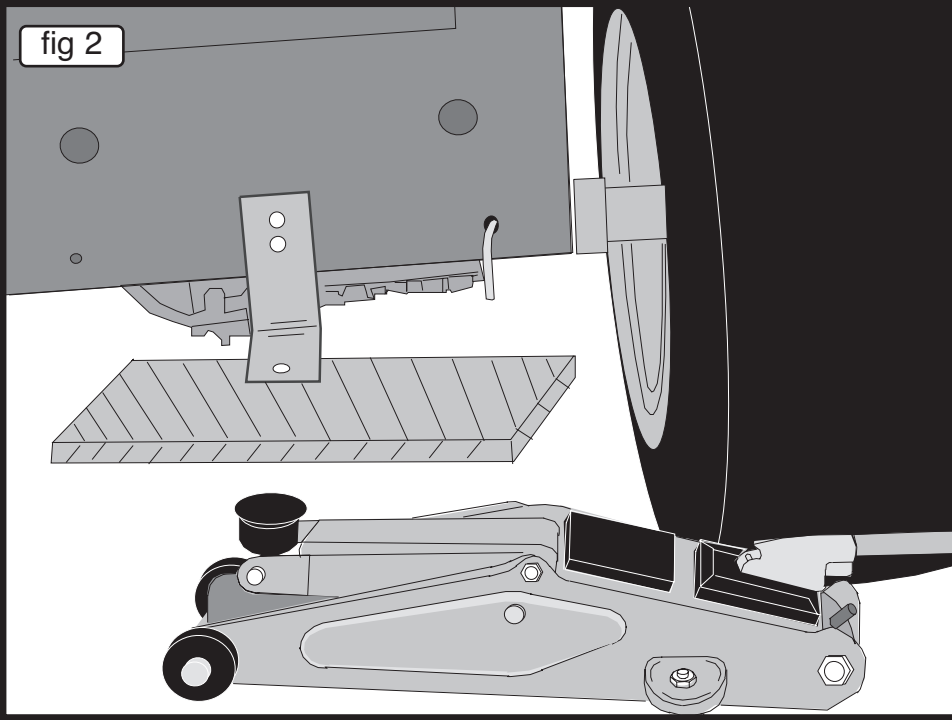
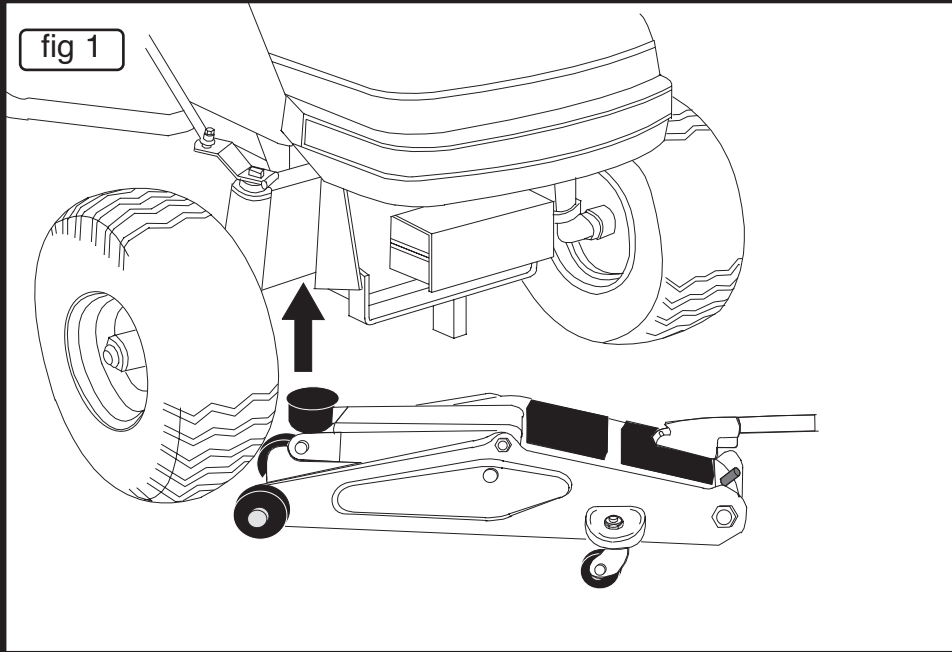

Tyres - Check List

Countax Tractors are fitted with grassland tyres that are designed to present a large area to the ground for grip; and are soft profile to prevent marking your turf. They are of thicker section and tougher than most 4 ply tyres.

Persistent punctures and tyre deflation are nevertheless a problem experienced by about 5% of Countax customers. This is not a problem just for Countax owners – it is shared by the users of all types of off-road machinery fitted with pneumatic tyres. In practically every case there is a common cause – THORNS! Blackthorn, Hawthorn, and Rose are usually at the bottom of it and will puncture any tyres not fitted with very expensive guards.

There are less expensive ways to overcome this problem – so check and avoid these possible causes:

1. The rim of the wheel has become damaged –breaking the seal on the tubeless tyre. There are two possible solutions:

* If the damage is not severe, treat with Countax tyre sealant (Pt No 52903501).

* If the damage is significant – order a new wheel

Front wheel - (Pt No 198000500)

Rear Wheel - (Pt No 198000700)

2. You have Hawthorn, Blackthorn, or Wild Rose in your hedges – these will puncture any tyre. It makes sense to check any area you intend to cut or drive over and to remove any branches.

The long-term solution is to treat all four tyres with Countax tyre sealant – follow the instructions on the bottle.

IF YOUR TYRES SPIN OR LOSE GRIP CHECK:

1. Are the tyres correctly inflated –

• Front wheels 0.8Kgf/cm (12lb PSI)* to 1.1Kgf/cm (16lb PSI)

• Rear wheels 0.43Kgf/cm (6lb PSI)* to 0.7Kgf/cm (10lb PSI)

*Pressure recommended for maximum grip.

2. Are you in too high a gear for the conditions? If so, select a lower gear or speed setting.

Deck Levels - Front to Back

The Cutter Deck should be set so that it is parallel to the surface it is cutting with a maximum variation from side to side, or front to back of 3mm. Check this by placing the Tractor on a hard level surface and measuring the clearance heights front to back and side to side with a steel ruler or tape with the Cutter set one adjustment up from its lowest position.

If the Cutter Deck seems to require levelling first check these other possible causes:

1. Are the tyres inflated correctly all round – if not, inflate to the correct pressures.
2. Are the Cutter Deck Hanger Brackets (fig 2) moving freely or are they hitching up. To check this lift the cutter deck to its highest position and lift and rock it, watching to ensure that the brackets move freely – if not clean and grease.
3. Is the Front Axle pivoting freely? – If not, clean and oil.
4. Is there any impact damage that has bent or distorted the Deck or Suspension Brackets (a matter for your dealer).

If the Deck is still uneven: -

LEVELLING FRONT TO BACK

(You need two people for this operation – one to lift the Deck while the other removes or relocates the Trunnion)

1. Ensure that the Anti-Scalp Wheels are all adjusted in the same hole – if not, rectify (fig 3).
2. Lower the Cutter Deck to a position one above the lowest setting – check levels with the ruler or tape.
3. Now locate the front to back Adjustment Rod to the right (offside) of the cutter. At the rear end of this Rod, near the rear offside wheel, you will find the Trunnion (fig 2) that links the rod to the Deck Hanger Bracket. Both the Trunnion and the Rod are threaded and adjustment is achieved by rotating the Trunnion to ‘in effect’ shorten or lengthen the Rod.
4. To free the Trunnion use a 9/16" spanner or socket to remove the 3/8" Nyloc nut and washer and push it free.
5. Rotate the Trunnion to advance it up the Rod to lift the back of the Deck. Rotate it the other way to lift the front. Adjustment is rapid so try one or two turns and relocate the Trunnion Bracket and secure – then check the effect. Repeat and re-check if necessary.

TOOLS REQUIRED:

Steel Ruler or Tape
9/16" AF Socket
1/2" Spanner
1/2" Socket
13mm Spanner
13mm Socket
Reversible Ratchet
12" Extension Bar

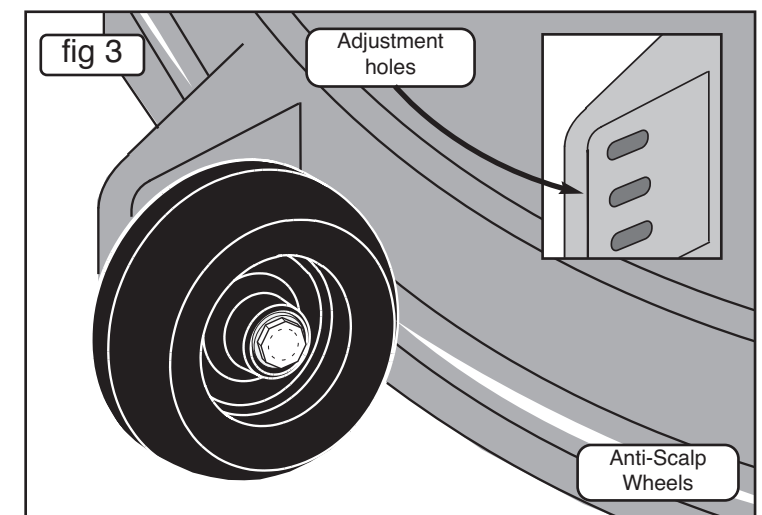
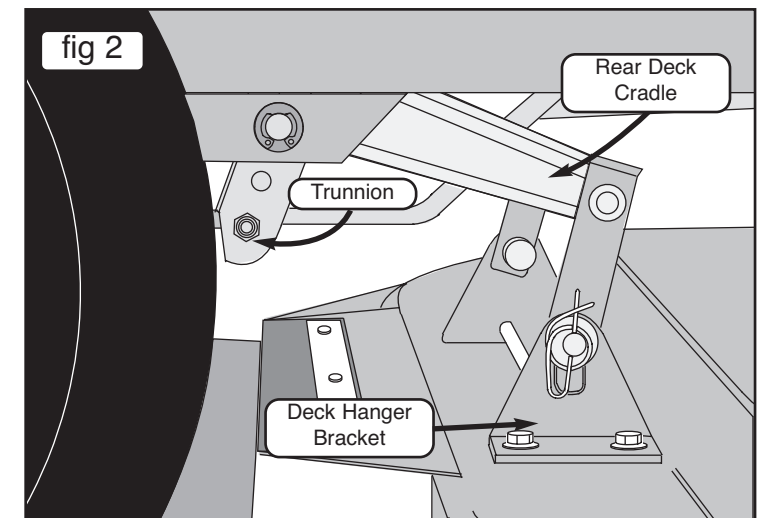
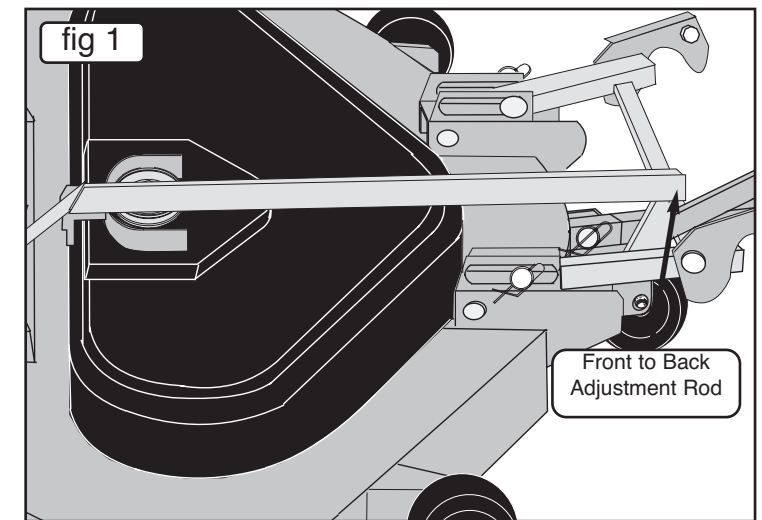

Cutter Levelling Side to Side

LEVELLING SIDE TO SIDE

Adjustment is best done with the Deck in a position one up from its lowest cut – check the level both sides and levelling is then achieved by adjusting the left (nearside) of the Deck at two points:

REAR ADJUSTMENT

1. Find the Deck Level Disc (fig 1) near the back nearside wheel. This has a concentric slot in which the Deck Levelling Rod is located.
2. Using a 13mm spanner, loosen the 8mm Nyloc nut **A** securing this stud just enough to permit some movement.
3. Now lift or depress the Deck depending on the adjustment you wish to achieve. This will move the disc up or down around the stud **B** – the higher up and nearer the centre of the disc the higher the Deck is lifted on the left hand side.
4. Check with your ruler or tape and having levelled the Deck at the rear, re-tighten the Nyloc nut.

FRONT ADJUSTMENT

1. Having levelled the rear of the Deck check if the front is level. If not, you will need to find the Deck Adjustment Plate (fig 2) which is forward of the Cutter Deck near the front (nearside) wheel.
2. Before making adjustments loosen the two sets of nuts and bolts (**A** and **B**) securing the Deck Levelling Bracket (**C**) using a 13mm spanner and 13mm socket.
3. Then, using a 13mm spanner, loosen (upper) locknut (**D**).
4. Now adjust the height by using a ratchet or spanner to turn the Nyloc nut (**E**) clockwise (up) to raise the Deck or anti-clockwise (down) to lower it.
5. When level is achieved tighten up all nuts and bolts.

For the closest cut set the anti-scalp wheels (fig 3) in the middle adjustment holes. If you are experiencing scalping this can be minimised by setting the wheels in the lowest adjustment holes.

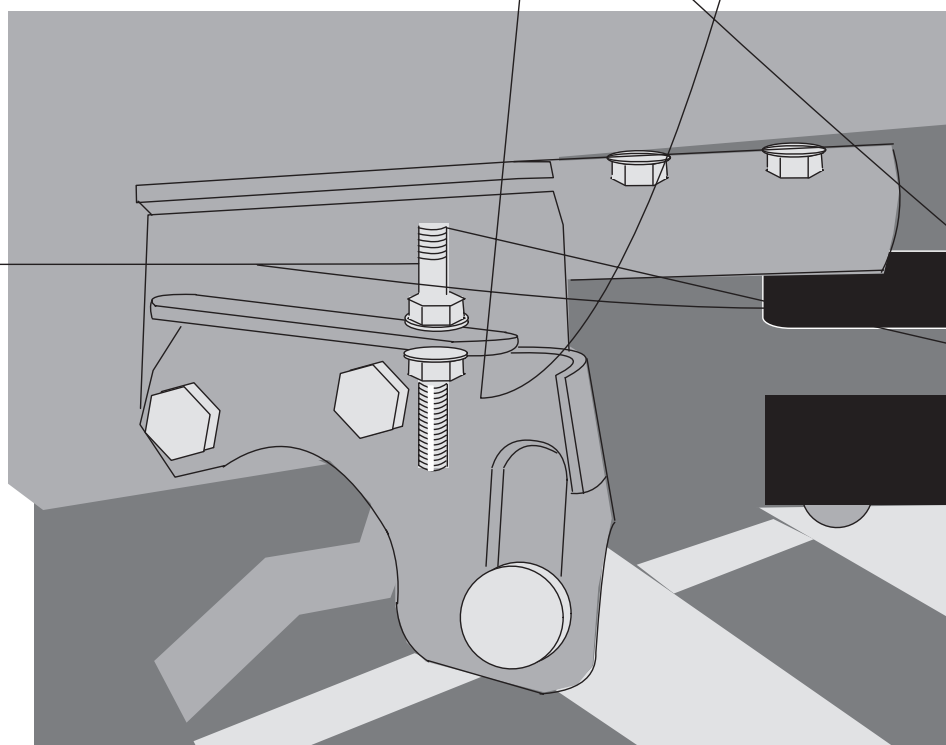
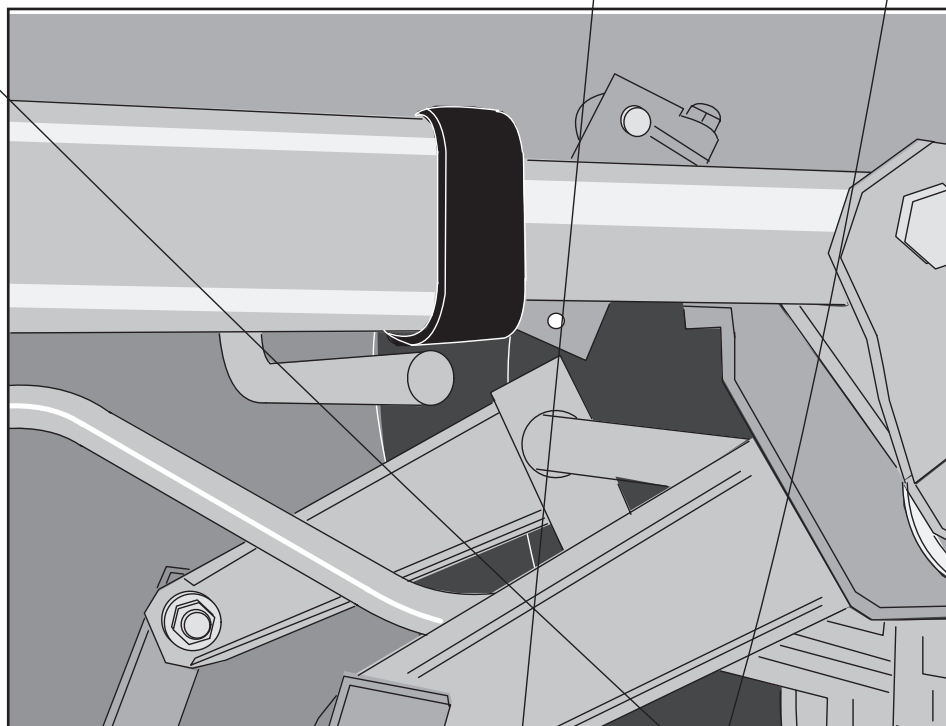

Collector Brush

Collector - Drive Belts

REPLACING AND TENSIONING PTO DRIVE BELT CONNECTION

It is important that the belt from PTO to collector (Part No. 22923400) is crossed over in the correct direction (fig 1) before being fitted over the collector pulley. The easiest way to do this is to place the belt on the PTO pulley and then stand behind the Tractor holding the belt with two hands. Turn the right hand above the left and fit the belt on to the collector pulley.

To check that you have this right - start your Tractor and engage the PTO lever and check that the brush is revolving against the forward direction of the Tractor (see page 15 fig 1).

CORRECT BELT TENSION

To check tension:

1. Lower the collector to the operating position and check the tension using a spring balance and a ruler.
2. Select a place on the belt midway between the PTO pulley and the collector pulley.
3. Pull and measure the deflection using a ruler (fig 2). It should be 19mm at 2kgs (4-5lbs).

If the tension needs to be adjusted - first:

1. Relocate the Collector from the Tractor.
2. Locate the adjustment holes on the Locking Arms. These holes take the nuts and bolts on which the Locking Arm hinges.
3. To increase tension on the belt undo each nut and bolt and relocate them one or more holes forward (towards the Tractor). To slacken move the bolts back. Ideally the bolts should be in the same hole on each Locking Arm, however fine adjustment to get the right tension may only permit you to move one bolt - this is OK but there should not be more than one hole difference from side to side.
4. Replace the Collector on the Tractor and re-check the belt tension.

CHECKING, TENSIONING AND REPLACING SIDE DRIVE BELT (fig 3)

1. First remove Collector from the Tractor (page 14).
2. To remove the plastic cover, remove the two nuts and bolts (A) using a 1/2" spanner and socket.
3. Using a 1/2" spanner and socket, slacken the nut and bolt (B) holding the tension pulley and slide the pulley out of the way.
4. Remove the belt and fit the Countax replacement (Dayco Super II A38 Part No. 22950300)
5. Tension the belt by sliding back and securing the belt tensioner. The tension is not critical but the belt must not be too tight. The ideal is 13mm (1/2") deflection at 2Kgs (4/5lbs) pull - use a spring balance and ruler or tape to check.
6. Make sure that the rectangular cover plate fits over the adjustment slot - failure to do this will allow cuttings and grit to accumulate and damage the pulleys and belt assembly.
7. Replace the plastic cover.

PLEASE NOTE:
The information contained in the following pages is given on the understanding that Countax accepts no responsibility for work carried out by a customer or for any damage thus caused, whether or not the service instructions have been misunderstood. To be absolutely sure that your warranty terms are not breached, service work should only be carried out by a Countax dealer.

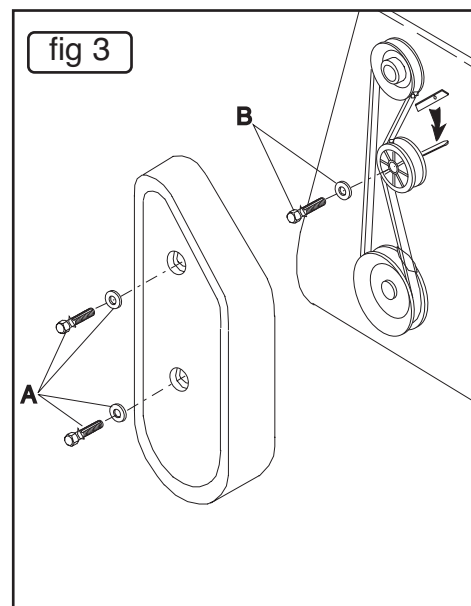
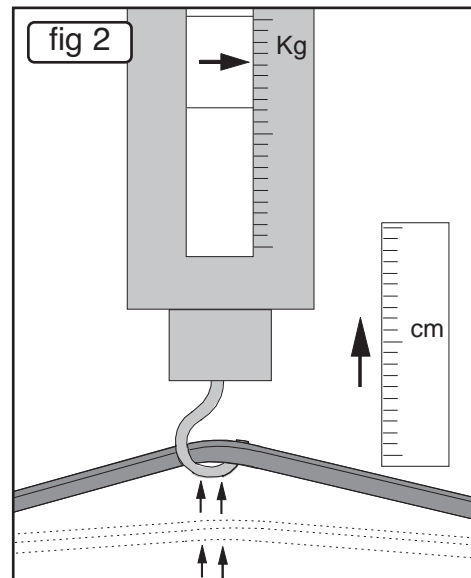
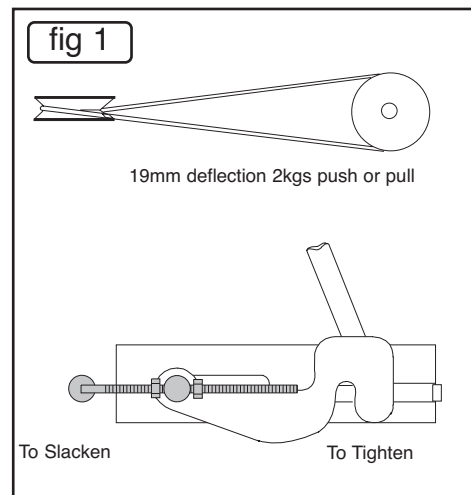

Cutter - Drive Belt

Specified Belts and Blades
Engine/Deck Belt - B57 Dayco Super II - Pt No. 22940100

Deck Internal Drive (Mulcher) - BB112
Pt No. 228000900
(Rear Discharge) - Dayco Super II BB155
Pt No. 22950200

Mulcher Blades x3 Pt No. - 16938100
IBS RH Blade Pt No. 169381300
IBS LH Blade Pt No. 169381400
IBS Front Blade Pt No. 1692000
PGC A49 Drive Belt Pt No. 22923400
PTO Drive Belt - Dayco Super II A92 -
Pt No. 22950100

Transmission Drive Belts - A91 Dayco Super II - Pt No. 228001500

N.B. Only use specified Belts and Blades - Never accept a substitute!

Before carrying out tests or adjustments (the problem may be simpler) - first CHECK the following points:

1. Is the Engine to Cutter Drive Belt slipping? Check that the Drive Belt Tension Lever (fig 1) under the left running board is in the rear (tensioned) position. If not, rectify - this is the most likely cause.
2. Has debris collected in the Cutter Deck Pulley Housing (Page 9)? If so remove the cover and remove the obstruction.

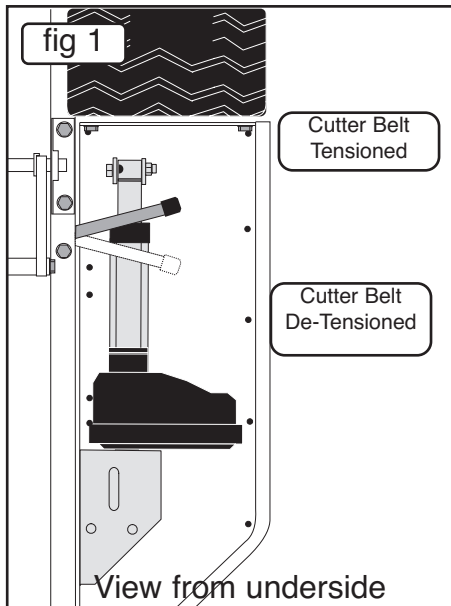

ENGINE TO CUTTER DRIVE BELT TENSION

The correct tension of the Cutter Drive Belt (Engine to Deck) is critical. If incorrectly set it can lead to engine damage.

To check the tension, follow this procedure:

1. Put the Deck in a middle cutting height position (5 on the decal).
2. Select the midway position on the Belt between the front (Electric Clutch) pulley and rear (Cutter Deck) pulley and using, a spring balance; apply a 2Kg (4 to 5lbs) pull (fig 2).
3. Using a ruler or tape, measure the deflection achieved which must be 13mm (1/2"). If more the belt tension must be increased, if less decreased.

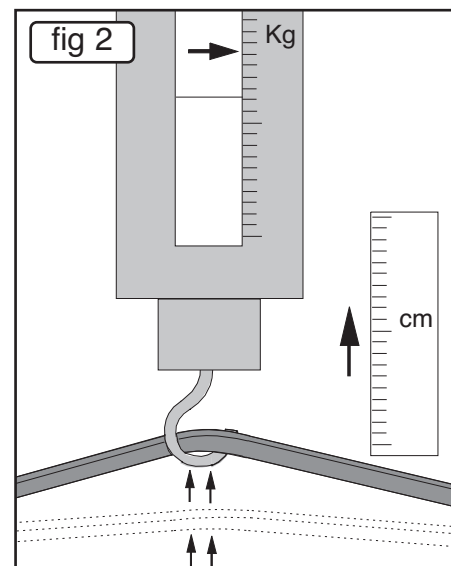

To correct the tension, follow this procedure:

1. Release the tension on the belt by pulling the Belt Tension Lever forward (see fig 1).
2. Taking care not to burn yourself on a hot exhaust, locate the Trunnion at the end of the Belt Tension Rod - lift the bonnet and look to the front (nearside) close to the exhaust (see fig 3).
3. Remove the spring clip and washer holding the Trunnion in place on the Deck Tension Cradle (fig 3a) and release the Trunnion so it can be turned.
4. Both the Trunnion and the Belt Tension

Rod are threaded. You increase Belt tension by winding the Trunnion towards the end of the Rod and reduce tension by winding in the reverse direction.

5. Having made the adjustment re-locate and secure the Trunnion, re-tension the Belt with the Belt Tensioner Lever - then re-check the Belt tension.

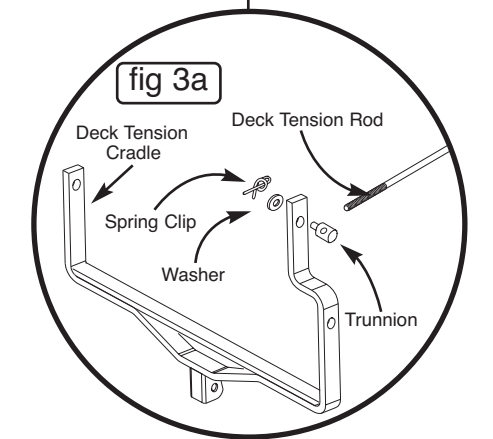
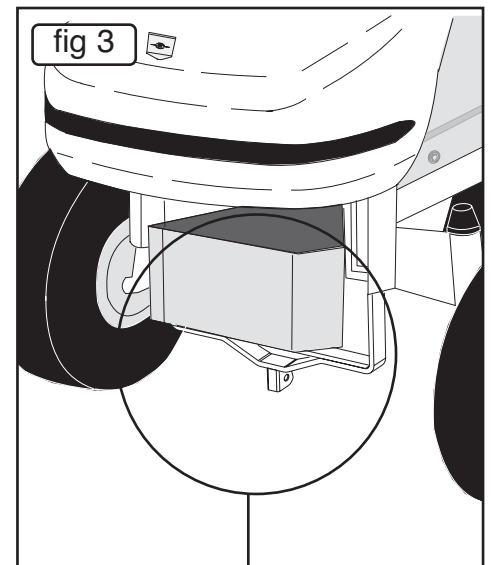

WARNING

ON NO ACCOUNT MUST THE TRACTOR BE RUN WITH THE ENGINE TO CUTTER DRIVE BELT OVER-TENSIONED AS IT WILL DAMAGE THE ENGINE. As any such damage will NOT be covered by warranty you may prefer that your dealer sets the tension.

Powered Collector

CONNECTION

To connect the Powered Collector to the Tractor, ensure that both are on an even surface with the Locking Levers (fig 3) on the collector facing the Lift Arms on the Tractor. Move the collector manually to the Tractor. Lower the Lift Arms using the button (Page 6 fig 3) on the dash console.

At the end of each Lift Arm you will find a Locating Lug. Slide the Channels on either side of the Powered Collector over the Lugs but do not engage the Locating Lever yet. Ensure that the Rubber Flap at the opening of the PGC locates on top of the Transmission Grass Deflector.

INSTALLING THE DRIVE BELT

Place the Drive Belt over the PTO pulley (beneath the Tractor seat). Standing adjacent to the Tractor, extend the belt with both hands parallel to the ground. Now twist the belt to form a figure '8' - the right-hand up and the left-hand down. In this position place the other end of the belt over the Powered Collector Pulley. Be sure that this is installed the right way round otherwise the brush will work in reverse and collection will be poor! Lock Locating Lever (fig 3) over the Lift Arm Lugs. Rotate Locking Clips over Lift Arm Lugs.

PTO DRIVE BELT TENSION

Engaging the Locating Lever tensions the belt which should not be run too tight - to check the tension there should be a 19mm deflection with light finger pressure (2Kgs) at a midway point between PTO pulley and Sweeper pulley. It is important after attaching the Sweeper to the Tractor, to check the Belt Tension and adjust this if necessary; this must be done before the Sweeper is put into operation and with the Sweeper on the ground.

With light finger pressure, 2kgs (4lbs), there should be a total deflection of 19mm (3/4") at midway point between PTO pulley and the Sweeper pulley. If a spring balance is available a pressure of 4-5lbs (1.81-2.26Kgs) is required for a deflection of 3/4" (19mm). If the Belt Tension is incorrect it can be adjusted by

movement of Sweeper Locking Levers on the threaded rod. Ensure the lock nuts are suitably tightened after adjustment.

N.B. Do not overtighten lock nuts as lever needs to pivot.

TO USE: RAISE SWEEPER TO THE TRANSPORT POSITION

Using the switch on the dashboard, lift the PGC to the transport position. We recommend that you drive to and from the area to be swept with the Powered Collector in this transport position and with the P.T.O disengaged.

When you reach the area to be swept, lower the collector and then engage the brushes by pushing the sprung PTO lever to the right to release and engage.

LOWER THE COLLECTOR

Using the lever (page 15 fig 2), lower the collector.

REMOVING THE NET

When removing the net, we suggest you employ the assistance of another person.

1. Partially open the Sweeper net (100mm (4")). Disconnect opening rod by pulling back on sprung locking tube and uncoupling from pin (fig 2).
2. Repeat either side.
3. Undo net locking clip (both sides), unhook levers from locating pins (see fig 2).
4. With either person standing each side of the collector net, slide the net off the locating arms.
5. Reverse operation for fitting.

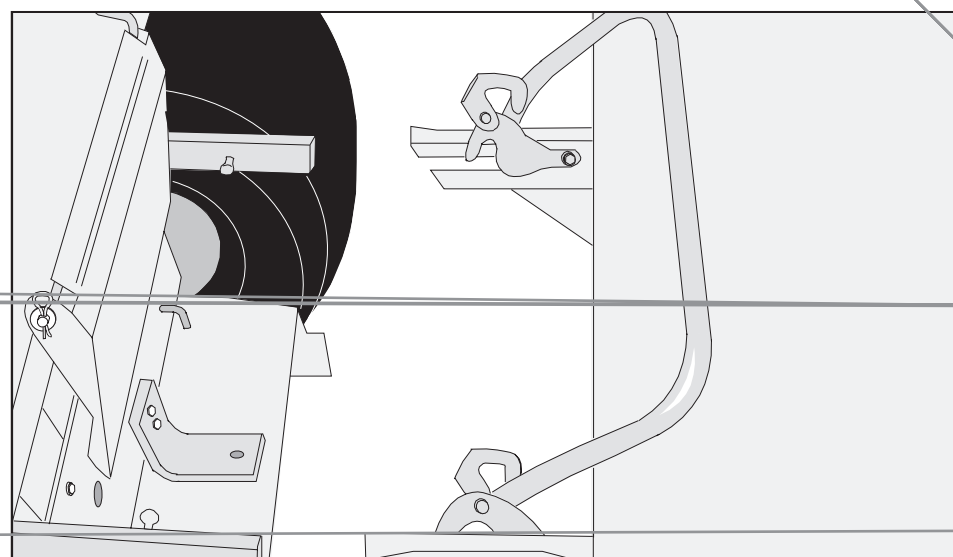

Collector Adjustments

