



1720 Hayden Drive  
 Carrollton, TX 75006  
 P: 469.892.1122  
 F: 469.892.1123  
 www.upgi.com

# chargers & maintainers

model # 24BC5000TFG-1

upg #71705

## Specifications:

3-Stage Switch Mode Fan Cooled Charger for GEL Sealed Lead Acid Batteries

Input Voltage:	100VAC- 240VAC
Input Frequency:	50Hz- 60Hz
Output Voltage:	
Bulk Charge:	28.4VDC +/- 0.5VDC
Float Charge:	26.4VDC +/- 0.5VDC
Output Current:	
Bulk Charge:	5A +/- 0.5A
Float Charge:	<1.2A
Over-Voltage Protection:	<30VDC
Over-Current Protection:	<5.5A
Leakage Current:	3mA Max.
Input Power (Watts):	<180 Watts
Input Standby Power (Watts):	<8 Watts
Efficiency:	75%
Battery Size Range:	12AH - 50AH
Dielectric Withstand Voltage:	4.2KV for 1 min. @ 3.5mA
Insulation Resistance:	50 MΩ @ 500VDC, Input to Output
Operating Temperature:	-10 Deg. Cent. to +40 Deg. Cent.
Storage Temperature:	-10 Deg. Cent. to +80 Deg. Cent.



## LED Status Indication:

LED 1: Power indicator – Power ON Red

LED 2: Dual color  
 Fast charge – Red  
 Float Charge - Green

## Protection:

Short Circuit Protection, Over Current Protection, Over Voltage Protection, Polarity Reversal

## Connector:

3 Pin D (XLR type), Pin 1 = Positive, Pin 2 & 3 = ground

## Safety Standards:

UL1012, CUL, FCC Part 15- Class B

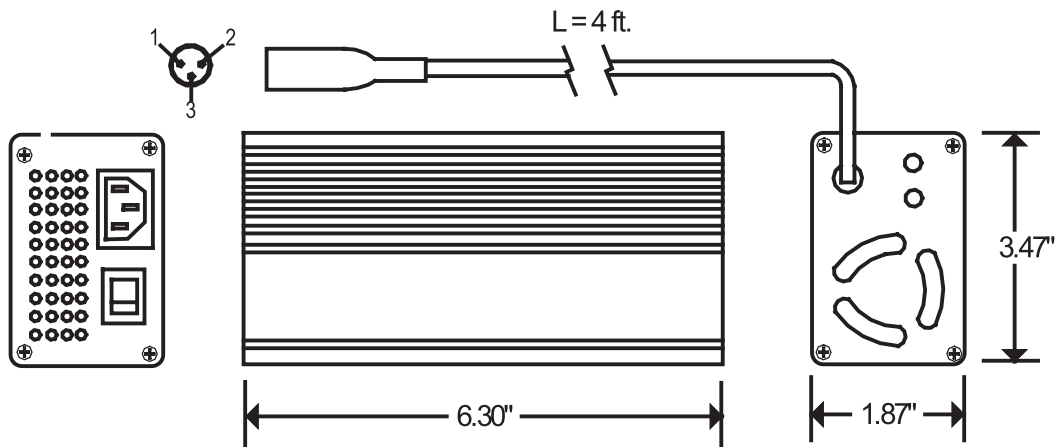

Note: 1) Charger supplied with 5 ft. AC 3-prong cord  
 2) Case material - Aluminum