

OWNER'S GUIDE

**Model Nos. 111-060
111-070**

10 CENTS

ROTARY MOWER

WARRANTY

For one year from date of purchase MTD Products Inc, will replace for the original purchaser, free of charge, F.O.B. factory or authorized service firm, any part or parts found to be defective in material or workmanship. All transportation charges on parts submitted for replacement under this warranty must be paid by the purchaser. This warranty does not include replacement of parts which become inoperative through misuse, excessive use, accident, neglect, improper maintenance or alterations by unauthorized persons. This warranty does not include the engine, motor, battery, battery charger or any component parts thereof. For service on these units refer to the applicable manufacturer's warranty.

The above warranty will apply only to the original owner and will be effective only if the warranty card has been properly processed. It will not apply where the unit has been used commercially.

Warranty service is available through your local authorized service dealer or distributor. UNDER NO CIRCUMSTANCES WILL THE RETURN OF A COMPLETE UNIT BE ACCEPTED BY THE FACTORY UNLESS PRIOR WRITTEN PERMISSION HAS BEEN EXTENDED.

SAFETY RULES

Your rotary mower is a precision piece of power equipment, not a plaything. Therefore exercise extreme caution at all times.

1. Remove all sticks, stones, wire and other hazardous items from lawn before mowing. Such items are dangerous to both the mower and individuals in the vicinity of the mower.
2. Always disconnect spark plug cable during repairs or refueling operations.
3. Always start engine from side opposite discharge chute.
4. NEVER place hands or feet under mower or near discharge chute while engine is running.
5. Do not tilt mower at extreme angle while engine is running. Cut grass on hills and banks sideways, not up and down.
6. Always stop engine when not cutting grass.
7. Do not fill gas tank while engine is running. Do not spill gasoline on hot engine.
8. Keep children and pets away from area at all times during mowing operation. Never allow mower to discharge grass toward any person.
9. Do not attempt to start engine while mower is resting in high grass.
10. Check all nuts and bolts, particularly the blade bolts, for tightness. This is especially important during the initial operation period. Make this same check periodically thereafter.
11. While operating the mower, if any foreign object is struck stop the mower and inspect for damage. Do not restart or operate the mower until all damage has been repaired.

WARNING: Should excessive vibration develop, check your blade and crankshaft immediately. Do not operate mower with an unbalanced blade, a damaged blade or a damaged crankshaft.

NOTE: This instruction manual covers various models and all accessories shown do not necessarily apply to your model mower.

If repairs or service is needed on the engine, please contact your nearest, authorized engine service outlet. Check the "Yellow Pages" of your telephone book under "Engines - Gasoline."



111-060
111-070

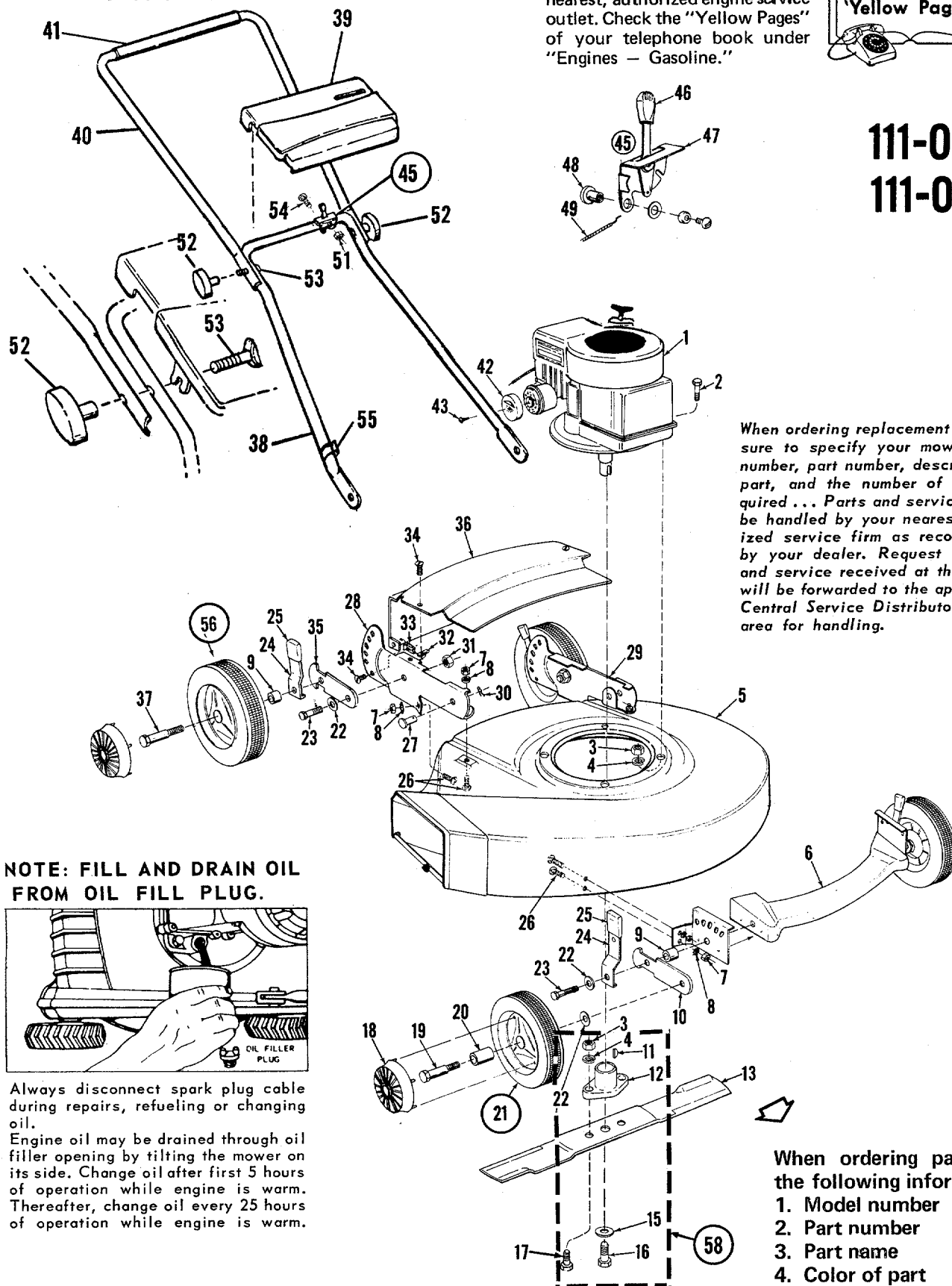

When ordering replacement parts, be sure to specify your mower model number, part number, description of part, and the number of parts required . . . Parts and service should be handled by your nearest authorized service firm as recommended by your dealer. Request for parts and service received at the factory will be forwarded to the appropriate Central Service Distributor in your area for handling.

NOTE: FILL AND DRAIN OIL FROM OIL FILL PLUG.

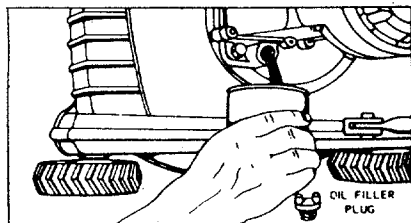

Always disconnect spark plug cable during repairs, refueling or changing oil.
Engine oil may be drained through oil filler opening by tilting the mower on its side. Change oil after first 5 hours of operation while engine is warm. Thereafter, change oil every 25 hours of operation while engine is warm.

When ordering parts give the following information:

1. Model number
2. Part number
3. Part name
4. Color of part

PARTS LIST FOR MOWER MODELS 111-060 AND 111-070

Ref. No.	Part Number 111-060	Part Number 111-070	DESCRIPTION
1	-----	-----	Engine
2	710-158	710-158	Hex Head Cap Screw 5/16-24 x 1-1/4 Long *
3	712-123	712-123	Hex Nut 5/16-24 Thread **
4	736-119	736-119	Spring Lockwasher 5/16 Screw **
5	438-9650	438-9656	Deck Assembly
6	438-9790	438-9791	Front Extension Fracket Assembly
7	712-107	712-107	Hex Nut 1/4-20 Thread *
8	736-498	736-498	Internal Lockwasher 1/4 Screw *
9	711-242	711-242	Spacer
10	310-7492	310-7492	Wheel Pivot Bar - Front
11	714-365	714-365	Key - Hi Pro #505 **
12	748-189	748-189	Blade Adapter **
13	312-7582	312-7581	Blade
15	736-217	736-217	Spring Lockwasher 3/8 Screw Heavy Duty **
16	710-489	710-489	Hex Head Cap Screw 3/8-24 x 1-1/2 Long - Heat Treated **
17	710-117	710-117	Hex Head Cap Screw 5/16-24 x 1 Long - Heat Treated **
18	305-9871	305-9871	Hub Cap
19	738-102	738-102	Axle Bolt - Front Wheel
20	305-7006	305-7006	Fortiflex Bearing
21	502-9392	502-9392	Wheel Assembly - Front
22	736-105	736-105	Belleville Washer
23	710-191	710-191	Hex Head Cap Screw 3/8-24 x 1-1/4 Long *
24	310-10238	310-10238	Spring Lever Assembly w/Knob
25	305-7520	305-7520	Knob
26	710-289	710-289	Hex Head Cap Screw 1/4-20 x 1/2 Long *
27	710-233	710-223	Weld Pin
28	438-9664	438-9664	Rear Wheel Bracket - Right Hand
29	438-9665	438-9665	Rear Wheel Bracket - Left Hand
30	714-104	714-104	Hairpin - Cotter *
31	712-214	712-214	Gripco Locknut 3/8-24 Thread *
32	712-207	712-207	Speed Nut
33	712-147	712-147	Speed Nut
34	710-192	710-192	Truss Head Machine Screw 10-24 x 3/8 Long *
35	310-9668	310-9668	Wheel Pivot Bar - Rear
36	438-9675	438-9673	Rear Cover
37	738-213	738-213	Axle Bolt - Rear Wheel
38	310-10009	310-10024	Handle - Lower
39	437-9998	437-9998	Handle Panel
40	310-10011	310-10011	Handle - Upper
41	718-143	718-143	Handle Grip
42	310-9278	310-9278	Exhaust Deflector
43	710-315	710-315	Hex Head Thread Cutting Screw Type "F" #8 x 5/8 Long *
45	310-10033	310-10033	Throttle Control (Complete)
46	305-7470	305-7470	Knob
47	310-9848	310-9848	Throttle Control Bracket †
48	901-7627	901-7627	Ferrule Assembly †
49	732-139	732-139	Conduit and Wire †
51	712-107	712-107	Hex Centerlock Nut 1/4-20 Thread *
52	394-9966	394-9966	Hand Knob
53	710-405	710-405	Curved Head Screw 5/16-18 x 1-3/4 Long *
54	710-606	710-606	Hex Head Cap Screw 1/4-20 x 1-1/2 Long *
55	746-128	746-128	Cable Clip
56	501-9392	501-9392	Wheel Assembly - Rear
58	901-10769	901-10769	Blade Adapter Kit/Complete (Less Blade)

* For faster service order standard nuts, bolts, and washers locally. If these items cannot be obtained locally, order by part number and size as shown on parts list.

† Part of Throttle Control Complete 310-10033.

** Part of Blade Adapter Kit Complete 901-10769.

ASSEMBLY INSTRUCTIONS

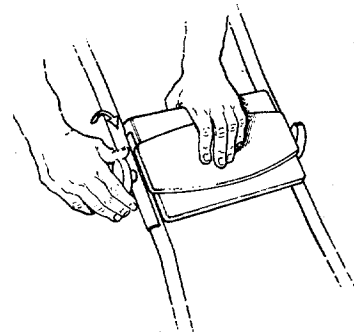
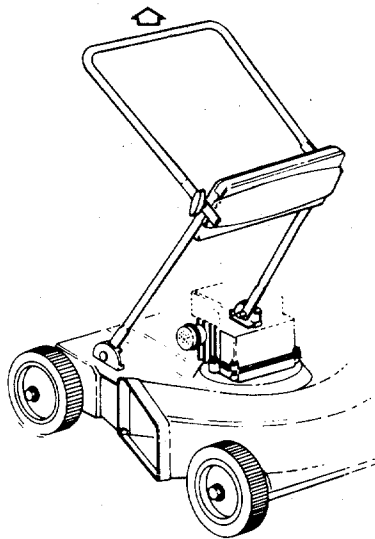
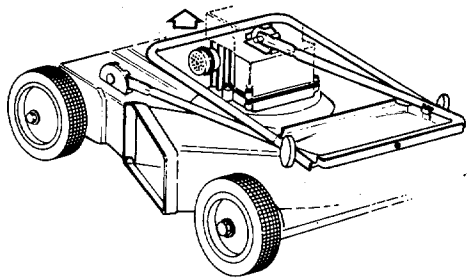

OPERATION

NOTE: For shipping purposes your mower is set with the wheels in a low cutting height position. For best results, raise the cutting position until it is determined which height is best for your lawn. See Adjustments.

1. Service engine with gas and oil. See Engine Manual packed with lawn mower for complete instructions for the care maintenance of engine. **READ DIRECTIONS CAREFULLY.**
2. When ready to start engine, place throttle control lever in "START" position and start engine in accordance with instructions in Engine Manual. After engine starts, move throttle control lever to desired engine speed. The engine is stopped by placing control lever in the "STOP" position.
3. Be sure that lawn is clear of stones, sticks, wire or other objects which could damage lawn mower or engine. For best results and to insure more even grass distribution, do not mow when lawn is excessively wet.
4. Check blade bolts for proper tightness.

ADJUSTMENTS

CAUTION: Do not at any time make any adjustment to lawn mower without first stopping engine and disconnecting spark plug wire.

CUTTING HEIGHT — An adjusting plate and thumb lever at each wheel position provides cutting height adjustment. Each adjusting plate has five holes. Height of cut will be changed when the thumb lever is moved from one hole to another. Simply depress thumb lever towards wheel and move wheel and lever assembly to desired position. Cutting height will be raised as lever is moved toward front and lowered as lever is moved toward rear. All wheels must be positioned in relative height of cut positions.

THROTTLE — If adjustment becomes necessary, the throttle control wire assembly can be reset as follows:

1. Loosen, but do not remove, screw securing throttle control wire assembly at engine.
2. Move throttle control lever on handle to "FAST" position.
3. Move lever, to which control wire is fastened at engine, to full open position and retighten screw to secure throttle control wire assembly.

LUBRICATION

IMPORTANT: Always stop engine and disconnect spark plug wire before cleaning, lubricating or doing any kind of work on lawn mower.

WHEELS: Wheel bearings are of lifetime Fortiflex. They require no lubrication.

THROTTLE: Periodically lubricate throttle control lever and throttle wire assembly with a few drops of light oil (S.A.E. No. 10 or 20) for ease of operation.

ENGINE: Follow Engine Manual for lubrication instructions.

MAINTENANCE

CUTTING BLADE — The blade may easily be removed for grinding or replacement as follows:

1. Remove bolt and lock washer holding blade and hub assembly to engine crankshaft.
2. Remove blade and hub assembly from engine crankshaft.
3. Remove two bolts, lock washers and nuts holding blade to blade hub.

When sharpening blade, follow the original angle of grind as a guide. It is extremely important that each cutting edge receives an equal amount of grinding to prevent an unbalanced blade. An unbalanced blade will cause excessive vibration when rotating at high speeds and may cause damage to the mower.

Upon reassembly, make certain all parts are assembled properly and tightened securely.

DECK — The underside of mower deck should be cleaned after each period of use as grass clippings, leaves, dirt and other matter will accumulate. This accumulation of grass clippings, etc. is undesirable as it will invite corrosion and may cause an uneven discharge of grass clippings at the next cutting.

The deck may be cleaned by tilting the mower forward or on its left side and scraping clean with a suitable tool or by washing with a stream of water from a garden hose.

CAUTION: Do not direct the stream of water at a hot engine as damage to the engine may result.

STORAGE — The following steps should be taken to prepare lawn mower for storage.

1. Clean and lubricate mower thoroughly as described in the preceding instructions.
2. Refer to Engine Manual for correct engine storage instructions.
3. Coat mower's blade with chassis grease to prevent rusting.
4. Place blocks under deck to raise tires clear of floor.
5. Store mower in a dry, clean area.

USING YOUR MOWER

For best results, do not cut wet grass because it tends to stick to underside of the mower thus preventing proper discharge of grass clippings. If wet grass must be cut, reduce engine speed and walking speed to help distribute the clippings more effectively.

New grass should be treated as wet grass, otherwise a normal walking speed is about the right pace for efficient mowing. . . The best mowing pattern is one that allows the clippings to discharge towards the uncut part of the lawn. This permits recutting of the clippings to further pulverize them. When cutting high weeds, discharge towards cut portion, then recut at right angles to first direction.

Lawn should be cut in the fall as long as there is growth.